



5014114902  
GS20M02-202010

**GS20 AC DRIVES INSTALLATION INSTRUCTIONS**

**SENSORLESS VECTOR CONTROL VARIABLE FREQUENCY MICRO-DRIVE**

- Please read this instruction sheet thoroughly before installation and retain for later reference.
- To ensure the safety of operators and equipment, only qualified personnel familiar with AC drives should install, wire, program, and operate the GS20 drive. Always read this instruction sheet thoroughly before using the GS20 drive, especially the WARNING, DANGER and CAUTION notes. If you have any questions, please contact AutomationDirect.

**PLEASE READ PRIOR TO INSTALLATION FOR SAFETY**

	<ul style="list-style-type: none"> <li>• The ground terminal of the GS20 drive must be grounded correctly. The grounding method must comply with the laws of the country where the GS20 drive is to be installed.</li> <li>• After power has been turned off, the capacitors in the GS20 drive may retain a charge for several minutes. To prevent personal injury, visually verify that the "CHARGE" LED has turned off. Then measure to confirm that the DC bus voltage level between terminals (+1) and (-) is less than 25VDC before touching any terminals. (Capacitor discharge will take at least 5 minutes for most GS20 models)</li> <li>• The CMOS ICs on the internal circuit boards of the GS20 drive are sensitive to static electricity. Please DO NOT touch the circuit boards with your bare hands before taking anti-static measures. Never disassemble the internal components or circuits.</li> <li>• If wiring changes must be made, turn off power to the GS20 drive before making those changes. Allow the internal DC bus capacitors in the GS20 drive sufficient time to discharge prior to making changes in power or control wiring. Failure to do so may result in short circuit and fire. To ensure personal safety, allow DC bus voltage to discharge to a safe level before making wiring changes to the GS20 drive.</li> <li>• DO NOT install the GS20 drive in locations subject to high temperature, direct sunlight, or flammable materials.</li> </ul>
	<ul style="list-style-type: none"> <li>• Never apply power to the output terminals U/T1, V/T2, W/T3 of the GS20 drive. If a fault occurs during operation of the GS20 drive, refer to the fault code descriptions and corrective actions to reset the fault before attempting to operate the GS20 drive.</li> <li>• DO NOT use Hi-pot test for internal components. The semi-conductors in the GS20 drive are easily damaged by high voltage.</li> </ul>
	<ul style="list-style-type: none"> <li>• Long motor lead lengths may result in reflective wave due to impedance mismatch between the motor cable and the motor. Reflective wave may damage the insulation of the motor. To avoid the possibility of reflective wave damage, use an inverter-rated motor with an insulation rating of 1600 volts. A load reactor installed between the GS20 drive and motor will help to mitigate reflective wave.</li> <li>• Nominal supply voltage to the GS20 drive should be less than or equal to 120/240/480 volts AC depending on GS20 model.</li> <li>• Nominal supply current capacity should be less than or equal to 100kA for all GS20 models.</li> <li>• The GS20 drive must be installed in a clean, well-ventilated and dry location, free from corrosive gases or liquids.</li> <li>• The GS20 drive must be stored within an ambient temperature range from -40°C to +85°C, and relative humidity range of 0% to 90% without condensation.</li> <li>• Do not apply AC power to the GS20 drive with the front cover removed. Following a fault of the GS20 drive, wait 5 seconds before pressing the RESET key.</li> <li>• To improve power factor, install a line reactor ahead of the GS20 drive. Do not install power correction capacitors in the main AC supply circuit to the GS20 drive to prevent drive faults due to over-current.</li> </ul>

**MINIMUM WIRING**

- AC input power to R/L1, S/L2, T/L3 (for single-phase input, use two of the terminals) (For applicability of 1-phase input power, please refer to Chapter 1 of the DURApulse GS20 AC Drives User Manual at [AutomationDirect.com](http://AutomationDirect.com).)
- Ground from the power supply
- Drive power to the motor (U, V, W on T1, T2, T3) (For use with 3-phase motors only!)
- Ground to the motor
- STO1 and STO2 (both must be wired through appropriate N.C. safety-rated contacts to DCM or the factory-installed jumpers must be left in place)

With this minimal wiring, the drive can be operated via the keypad to test the motor and drive installation. See the "Parameter Set Up" (page 4) section to configure the drive for keypad operation.

**RECOMMENDED SAFETY WIRING**

We strongly recommend that customers use the STO safety feature.

The Safe Torque Off (STO) function turns off the power supplied to the motor through the hardware, so that the motor cannot produce torque. This method of removing power from the motor is considered an emergency stop, also known as "coast to stop."

To use this feature, disconnect the appropriate factory-installed jumpers and wire a safety relay, safety PLC, or E-Stop pushbutton as shown. See Main Wiring (Power Circuit) (page 1) for wiring the GS20.

**WIRING DIAGRAMS**

**RFI JUMPER REMOVAL**



If the power distribution system supplying the GS20 AC drive is a floating (IT) or an asymmetric ground system (including most 120V inputs), the RFI jumper must be removed.

Removing the RFI jumper uncouples the internal RFI capacitor (filter capacitor) between the GS20 drive frame and circuitry to avoid damaging those circuits and (according to IEC 61800-3) to reduce ground leakage current.

**GS20 Frame A through F**

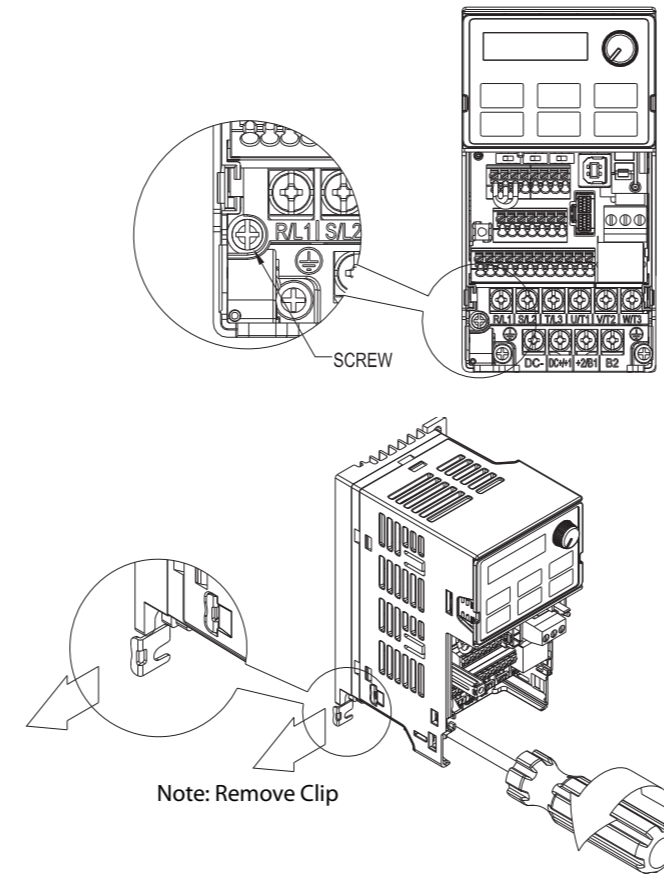

**MAIN WIRING (POWER CIRCUIT)**

For main (power) wiring terminal specifications, Please refer to "Specifications for Wiring Terminals - Main-Circuit Terminals" (page 2).

**GS20 ALL FRAMES**

\*(Note that 1-phase drives do not have a T/L3 terminal)

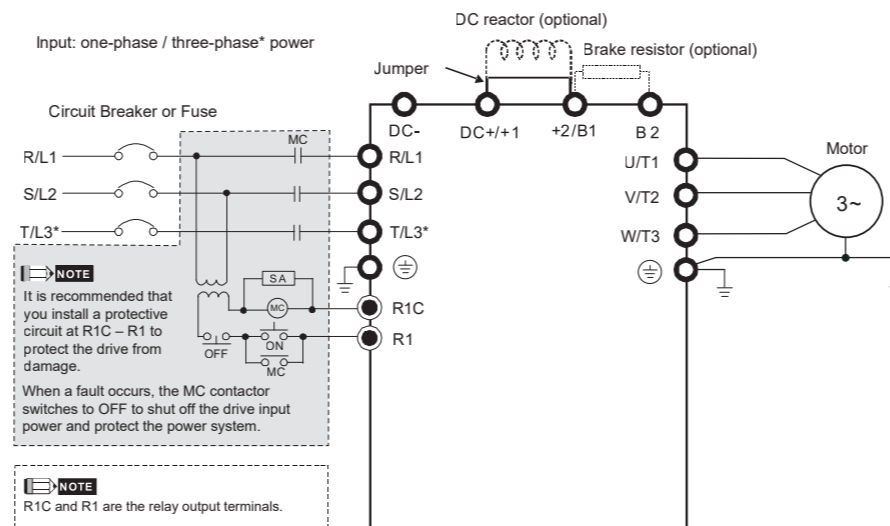

**GS20 CONTROL TERMINAL WIRING**

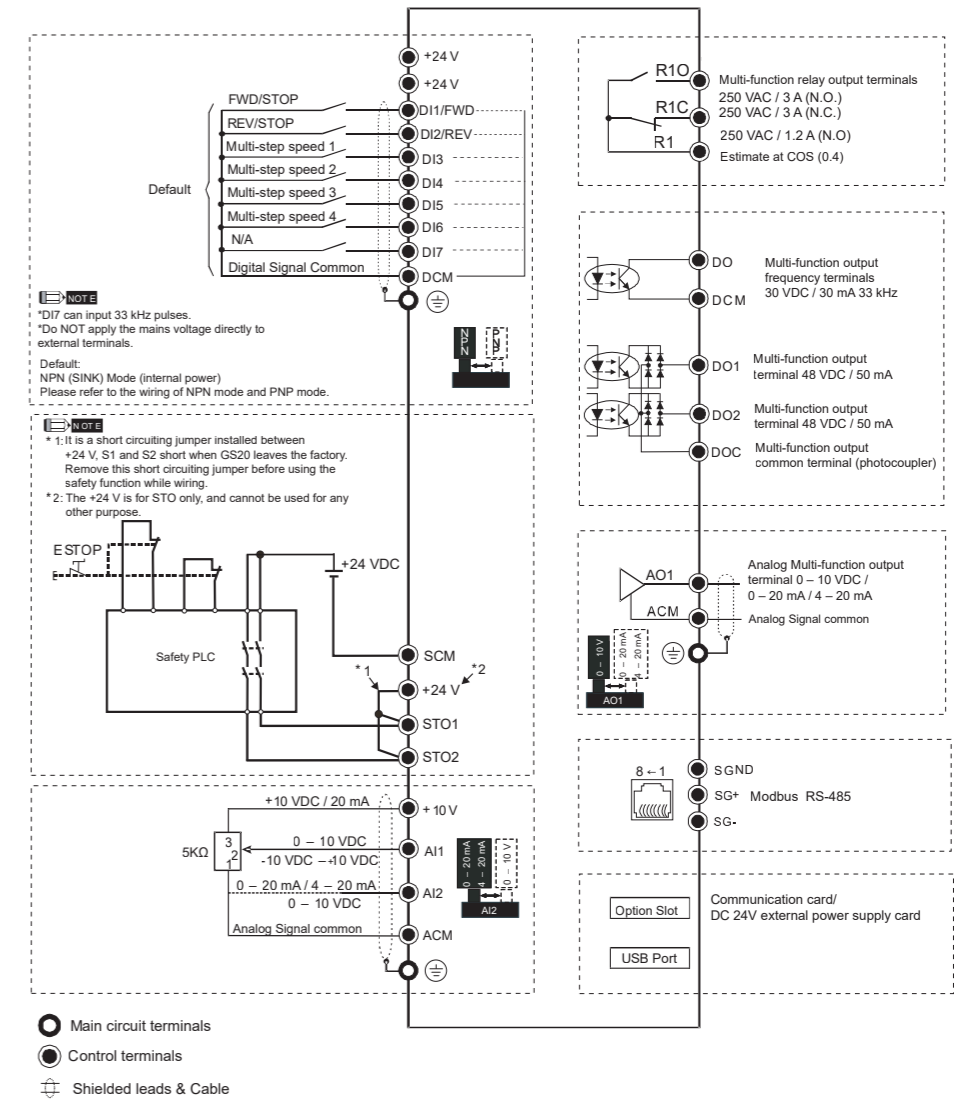

① Sink Mode with internal power (+24 V<sub>DC</sub>)

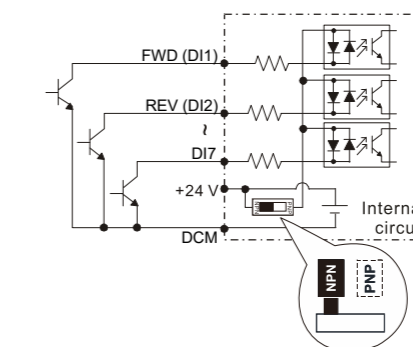

② Source Mode with internal power (+24 V<sub>DC</sub>)

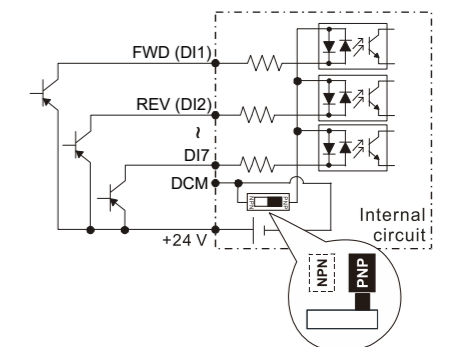

③ Sink Mode with external power

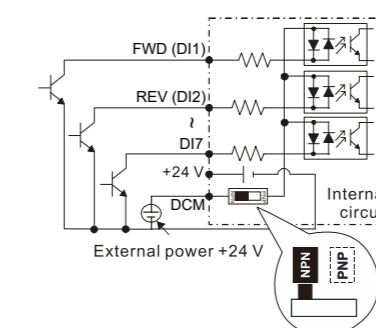

④ Source Mode with external power

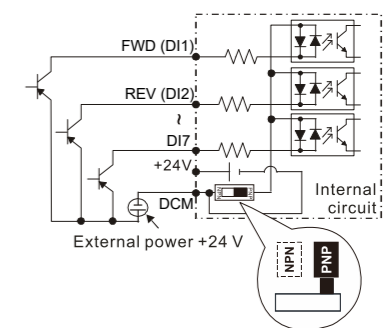

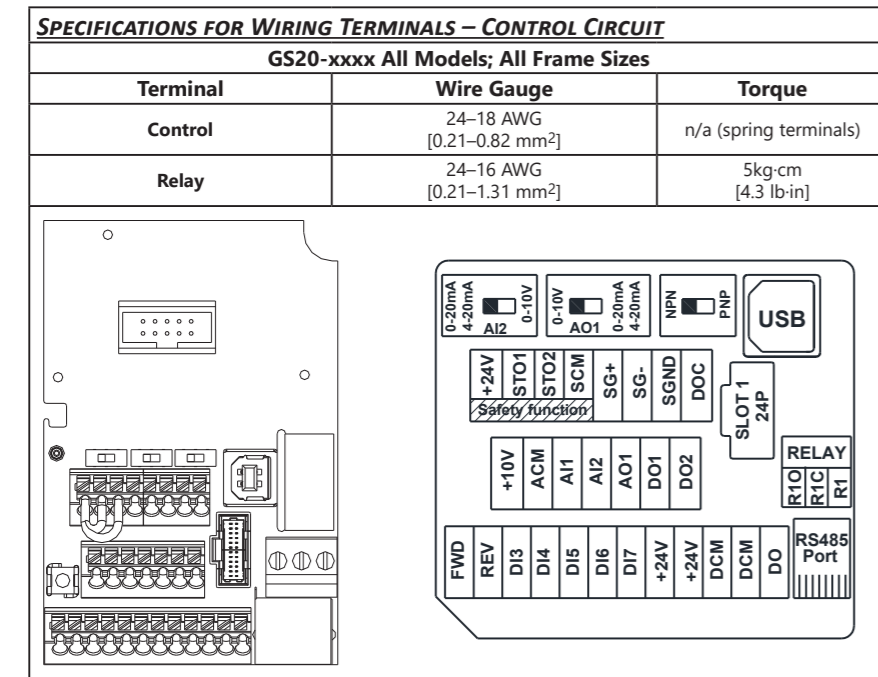
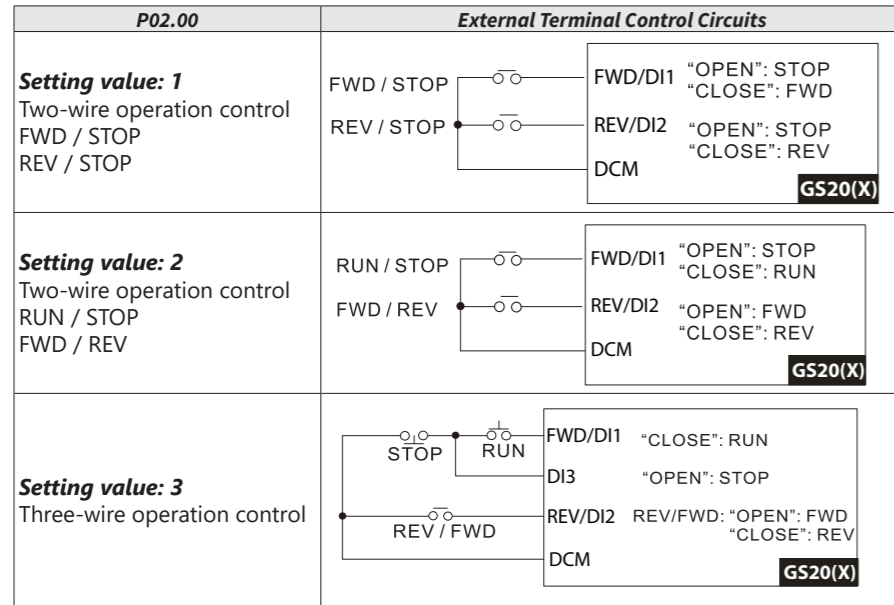

**WIRING PRECAUTIONS**

- The factory default condition is +24 V/ S1/ S2 shorted by jumper, as shown in the block 1 of the figure above. Refer to the wiring chapter of the User Manual for more details.
- The +24 V power supply for safety function is only for STO use and cannot be used for other purposes.
- The RELAY terminal uses the PCB terminal block:
  - Tighten the wiring with a 3.5 mm width and 0.6 mm thickness slotted screwdriver.
  - The ideal length of stripped wire at the connection side is 6–7 mm.
  - When wiring bare wires, make sure they are perfectly arranged to go through the wiring holes.
- The control circuit terminal uses a spring clamp terminal block:
  - Tighten the wiring with a 2.5 mm width and 0.4 mm thickness slotted screwdriver.
  - The ideal length of stripped wire at the connection side is 9 mm.

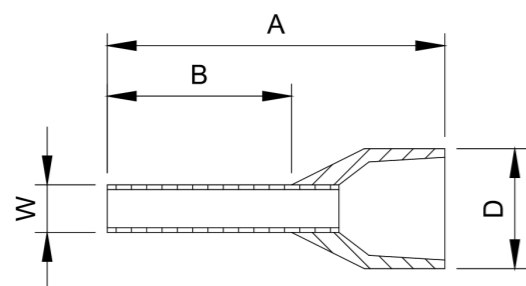

**RECOMMENDED MODELS OR DIMENSIONS FOR FERRULE TERMINALS**

Wire Gauge	Manufacturer	Model Name	A (MAX)	B (MAX)	D (MAX)	W (MAX)
0.25 mm <sup>2</sup> [24 AWG]	PHOENIX CONTACT	AI 0,25- 8 YE	12.5	8	2.6	1.1
0.34 mm <sup>2</sup> [22 AWG]	PHOENIX CONTACT	AI 0,34- 8 TQ	12.5	8	3.3	1.3
0.5 mm <sup>2</sup> [20 AWG]	PHOENIX CONTACT	AI 0,5 - 8 WH	14	8	3.5	1.4
	Z+F	V30AE000006	14	8	2.6	1.15

**SPECIFICATIONS FOR WIRING TERMINALS – MAIN-CIRCUIT TERMINALS**

**Notes:**

- If you install at Ta 45°C above environment, please use copper wire with a 600V voltage rating and temperature resistance of 90°C or higher.
- For UL compliant installation, you must:
  - Use 75°C temperature resistant copper wire or better. Do not reduce wire gauge when using higher temperature wire.
  - Use the specific ring lug part listed in the table below.
  - Use crimp tool KST2000D-1322 or IZUMI 5N18 for 22–8 AWG wire, or IZUMI 9H-60 for 6–4 AWG wire.

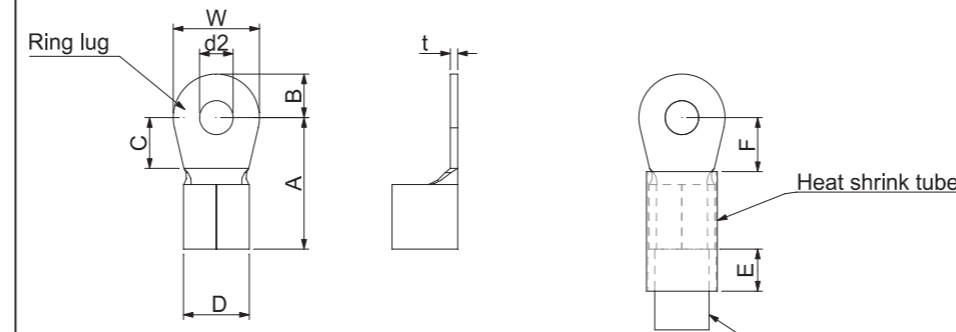

Figure 1.

Figure 2.

Drive Models	Max Wire Gauge	Min Wire Gauge	Ring Lug P/N	Screw	Torque (±10%)	Ring Lug Dimensions (mm)																														
Frame A	14AWG [2.1 mm <sup>2</sup> ]	16AWG [1.3 mm <sup>2</sup> ]	RNBS 2-3.7	M3.5	9 kg-cm [7.8 lb-in.] [0.88 N-m]	<table border="1"> <thead> <tr> <th>Dimension</th> <th>Value</th> <th>Min/Max</th> </tr> </thead> <tbody> <tr><td>A</td><td>9.8</td><td>Max</td></tr> <tr><td>B</td><td>3.2</td><td>Max</td></tr> <tr><td>C</td><td>4.8</td><td>Min</td></tr> <tr><td>D</td><td>4.1</td><td>Max</td></tr> <tr><td>d2</td><td>3.7</td><td>Min</td></tr> <tr><td>E</td><td>13.0</td><td>Min</td></tr> <tr><td>F</td><td>4.2</td><td>Min</td></tr> <tr><td>W</td><td>6.6</td><td>Max</td></tr> <tr><td>t</td><td>0.8</td><td>Max</td></tr> </tbody> </table>	Dimension	Value	Min/Max	A	9.8	Max	B	3.2	Max	C	4.8	Min	D	4.1	Max	d2	3.7	Min	E	13.0	Min	F	4.2	Min	W	6.6	Max	t	0.8	Max
							Dimension	Value	Min/Max																											
							A	9.8	Max																											
							B	3.2	Max																											
							C	4.8	Min																											
							D	4.1	Max																											
							d2	3.7	Min																											
							E	13.0	Min																											
							F	4.2	Min																											
							W	6.6	Max																											
t	0.8	Max																																		
GS21-10P2																																				
GS21-20P2																																				
GS23-20P2																																				
GS23-20P5																																				
GS21-10P5																																				
GS21-20P5																																				
GS23-40P5																																				
GS23-21P0																																				
GS23-41P0																																				
GS23-51P0																																				
Frame B	12AWG [3.3 mm <sup>2</sup> ]	14AWG [2.1 mm <sup>2</sup> ]	RNBS 2-4	M4	15 kg-cm [13.0 lb-in.] [1.47 N-m]	<table border="1"> <thead> <tr> <th>Dimension</th> <th>Value</th> <th>Min/Max</th> </tr> </thead> <tbody> <tr><td>A</td><td>12.1</td><td>Max</td></tr> <tr><td>B</td><td>3.6</td><td>Max</td></tr> <tr><td>C</td><td>6.1</td><td>Min</td></tr> <tr><td>D</td><td>5.6</td><td>Max</td></tr> <tr><td>d2</td><td>4.3</td><td>Min</td></tr> <tr><td>E</td><td>13.0</td><td>Min</td></tr> <tr><td>F</td><td>4.5</td><td>Min</td></tr> <tr><td>W</td><td>7.2</td><td>Max</td></tr> <tr><td>t</td><td>1</td><td>Max</td></tr> </tbody> </table>	Dimension	Value	Min/Max	A	12.1	Max	B	3.6	Max	C	6.1	Min	D	5.6	Max	d2	4.3	Min	E	13.0	Min	F	4.5	Min	W	7.2	Max	t	1	Max
							Dimension	Value	Min/Max																											
							A	12.1	Max																											
							B	3.6	Max																											
C	6.1	Min																																		
D	5.6	Max																																		
d2	4.3	Min																																		
E	13.0	Min																																		
F	4.5	Min																																		
W	7.2	Max																																		
t	1	Max																																		
GS23-22P0																																				
GS23-42P0																																				
GS21-21P0																																				

**SPECIFICATIONS FOR WIRING TERMINALS – MAIN-CIRCUIT TERMINALS (CONTINUED)**

Drive Models	Max Wire Gauge	Min Wire Gauge	Ring Lug P/N	Screw	Torque (±10%)	Ring Lug Dimensions (mm)																														
Frame C	8AWG [8.4 mm <sup>2</sup> ]	10AWG [5.3 mm <sup>2</sup> ]	RNBS 5-4	M4	20 kg-cm [17.4 lb-in.] [1.96 N-m]	<table border="1"> <thead> <tr> <th>Dimension</th> <th>Value</th> <th>Min/Max</th> </tr> </thead> <tbody> <tr><td>A</td><td>17.8</td><td>Max</td></tr> <tr><td>B</td><td>5.0</td><td>Max</td></tr> <tr><td>C</td><td>6.1</td><td>Min</td></tr> <tr><td>D</td><td>7.2</td><td>Max</td></tr> <tr><td>d2</td><td>4.3</td><td>Min</td></tr> <tr><td>E</td><td>13.0</td><td>Min</td></tr> <tr><td>F</td><td>5.5</td><td>Min</td></tr> <tr><td>W</td><td>8.0</td><td>Max</td></tr> <tr><td>t</td><td>1.2</td><td>Max</td></tr> </tbody> </table>	Dimension	Value	Min/Max	A	17.8	Max	B	5.0	Max	C	6.1	Min	D	7.2	Max	d2	4.3	Min	E	13.0	Min	F	5.5	Min	W	8.0	Max	t	1.2	Max
							Dimension	Value	Min/Max																											
							A	17.8	Max																											
							B	5.0	Max																											
							C	6.1	Min																											
							D	7.2	Max																											
							d2	4.3	Min																											
							E	13.0	Min																											
F	5.5	Min																																		
W	8.0	Max																																		
t	1.2	Max																																		
GS21-11P0																																				
GS21-22P0																																				
GS21-23P0																																				
GS23-23P0																																				
GS23-25P0																																				
GS23-43P0																																				
GS23-45P0																																				
GS23-53P0																																				
GS23-55P0																																				
Frame D	8AWG [8.4 mm <sup>2</sup> ]	10AWG [5.3 mm <sup>2</sup> ]	RNBS 5-4	M4	20 kg-cm [17.4 lb-in.] [1.96 N-m]	<table border="1"> <thead> <tr> <th>Dimension</th> <th>Value</th> <th>Min/Max</th> </tr> </thead> <tbody> <tr><td>A</td><td>17.8</td><td>Max</td></tr> <tr><td>B</td><td>5.0</td><td>Max</td></tr> <tr><td>C</td><td>6.1</td><td>Min</td></tr> <tr><td>D</td><td>7.2</td><td>Max</td></tr> <tr><td>d2</td><td>4.3</td><td>Min</td></tr> <tr><td>E</td><td>13.0</td><td>Min</td></tr> <tr><td>F</td><td>5.5</td><td>Min</td></tr> <tr><td>W</td><td>8.0</td><td>Max</td></tr> <tr><td>t</td><td>1.2</td><td>Max</td></tr> </tbody> </table>	Dimension	Value	Min/Max	A	17.8	Max	B	5.0	Max	C	6.1	Min	D	7.2	Max	d2	4.3	Min	E	13.0	Min	F	5.5	Min	W	8.0	Max	t	1.2	Max
							Dimension	Value	Min/Max																											
							A	17.8	Max																											
							B	5.0	Max																											
							C	6.1	Min																											
D	7.2	Max																																		
d2	4.3	Min																																		
E	13.0	Min																																		
F	5.5	Min																																		
W	8.0	Max																																		
t	1.2	Max																																		
GS23-27P5																																				
GS23-47P5																																				
GS23-4010																																				
GS23-57P5																																				
GS23-5010																																				
Frame E	6AWG [13.3 mm <sup>2</sup> ]	4AWG [21.2 mm <sup>2</sup> ]	RNBS 22-5	M5	25 kg-cm [21.7 lb-in.] [2.45 N-m]	<table border="1"> <thead> <tr> <th>Dimension</th> <th>Value</th> <th>Min/Max</th> </tr> </thead> <tbody> <tr><td>A</td><td>27.1</td><td>Max</td></tr> <tr><td>B</td><td>6.1</td><td>Max</td></tr> <tr><td>C</td><td>10.5</td><td>Min</td></tr> <tr><td>D</td><td>11.5</td><td>Max</td></tr> <tr><td>d2</td><td>5.3</td><td>Min</td></tr> <tr><td>E</td><td>13.0</td><td>Min</td></tr> <tr><td>F</td><td>6.5</td><td>Min</td></tr> <tr><td>W</td><td>12.2</td><td>Max</td></tr> <tr><td>t</td><td>1.7</td><td>Max</td></tr> </tbody> </table>	Dimension	Value	Min/Max	A	27.1	Max	B	6.1	Max	C	10.5	Min	D	11.5	Max	d2	5.3	Min	E	13.0	Min	F	6.5	Min	W	12.2	Max	t	1.7	Max
							Dimension	Value	Min/Max																											
							A	27.1	Max																											
							B	6.1	Max																											
C	10.5	Min																																		
D	11.5	Max																																		
d2	5.3	Min																																		
E	13.0	Min																																		
F	6.5	Min																																		
W	12.2	Max																																		
t	1.7	Max																																		
GS23-2010																																				
GS23-2015*																																				
GS23-4015																																				
GS23-4020																																				
Frame F	2AWG [33.6 mm <sup>2</sup> ]	6AWG [13.3 mm <sup>2</sup> ]	RNBS 14-6	M6	40 kg-cm [34.7 lb-in.] [3.92 N-m]	<table border="1"> <thead> <tr> <th>Dimension</th> <th>Value</th> <th>Min/Max</th> </tr> </thead> <tbody> <tr><td>A</td><td>35.0</td><td>Max</td></tr> <tr><td>B</td><td>9.0</td><td>Max</td></tr> <tr><td>C</td><td>13.3</td><td>Min</td></tr> <tr><td>D</td><td>14.0</td><td>Max</td></tr> <tr><td>d2</td><td>6.2</td><td>Min</td></tr> <tr><td>E</td><td>13.0</td><td>Min</td></tr> <tr><td>F</td><td>19.5</td><td>Min</td></tr> <tr><td>W</td><td>18.0</td><td>Max</td></tr> <tr><td>t</td><td>1.8</td><td>Max</td></tr> </tbody> </table>	Dimension	Value	Min/Max	A	35.0	Max	B	9.0	Max	C	13.3	Min	D	14.0	Max	d2	6.2	Min	E	13.0	Min	F	19.5	Min	W	18.0	Max	t	1.8	Max
							Dimension	Value	Min/Max																											
							A	35.0	Max																											
							B	9.0	Max																											
C	13.3	Min																																		
D	14.0	Max																																		
d2	6.2	Min																																		
E	13.0	Min																																		
F	19.5	Min																																		
W	18.0	Max																																		
t	1.8	Max																																		
GS23-2020																																				
GS23-4025																																				
GS23-4030																																				

\* The GS23-2015 drive must be wired with a ring terminal of the specified dimensions.

**DIGITAL KEYPAD FUNCTIONS AND INDICATIONS**

Description of the functions of the keys and indicators of the GS20 AC Drive Keypad.

**NOTE:** Drive default is AUTO mode. There is no indication from the keypad of the mode. Local mode can be set with I/O configuration or GS4-KPD only.



**KEYPAD NAVIGATION EXAMPLE**

Instruction	Press Key	Display Will Show
First menu to display after power up.	n/a	Displays the present frequency setting of the drive RUN ● FWD ● REV ● <b>F5000</b> ● STOP ● PLC ●
Press MENU once from startup.	MENU	Displays the actual output frequency of the drive RUN ● FWD ● REV ● <b>45000</b> ● STOP ● PLC ●
Press MENU twice from startup.	MENU	Displays user defined output RUN ● FWD ● REV ● <b>U 180</b> ● STOP ● PLC ●
Press MENU three times from startup.	MENU	Displays output current RUN ● FWD ● REV ● <b>A 500</b> ● STOP ● PLC ●
Press MENU four times from startup. Displays Frd if the drive is currently configured for Forward operation. Press the UP or DOWN key to change to Reverse. Press ENTER to confirm the change.	MENU, UP/DOWN, ENTER	Displays the Forward command if configured for Forward operation. RUN ● FWD ● REV ● <b>Frd</b> ● STOP ● PLC ●
		Displays the Reverse command if configured for Reverse operation. RUN ● FWD ● REV ● <b>rEv</b> ● STOP ● PLC ●
Press MENU five times from startup. Displays the current PLC setting. Press the UP or DOWN arrow keys to change the PLC setting, then press ENTER to confirm.	MENU, UP/DOWN, ENTER	Displays the current PLC setting. RUN ● FWD ● REV ● <b>PLC0</b> ● STOP ● PLC ●
Enable the counter by setting parameter 00.04 to 1. See the user manual for full instructions on using the counter.	MENU	Displays the counter value RUN ● FWD ● REV ● <b>c 20</b> ● STOP ● PLC ●
After selecting the desired menu option, press ENTER to bring up the parameter number (Format XX.YY). Use the UP and DOWN arrow keys to change the parameter number as needed, then press ENTER to adjust the parameter value.	ENTER, UP/DOWN, ENTER	Displays the parameter number RUN ● FWD ● REV ● <b>0600</b> ● STOP ● PLC ●
From the parameter number screen, press ENTER to bring up the current value of the selected parameter. Use the UP and DOWN arrows to adjust the value. Press ENTER again to confirm the choice.	ENTER, UP/DOWN	Displays the value of the selected parameter RUN ● FWD ● REV ● <b>10</b> ● STOP ● PLC ●
Once a desired parameter value has been set using the UP and DOWN arrow keys, press ENTER to save the choice and display End message.	ENTER	End message. Displays when data has been accepted and stored RUN ● FWD ● REV ● <b>End</b> ● STOP ● PLC ●
Displays when an external fault is detected.	n/a	External fault message RUN ● FWD ● REV ● <b>EF</b> ● STOP ● PLC ●
Displays when data is not accepted or the value exceeded	n/a	Error message. RUN ● FWD ● REV ● <b>Err</b> ● STOP ● PLC ●

Scroll sequentially through the rest of the parameters in the "Basic Configuration" Quick-Start group, and set those parameters as needed for your application. After changing all of the applicable parameters, press "MENU" key to return to the Menu screen, and then press "ESC" key to return to the home screen.

**GS20 FAULT CODES**

Fault Codes	
0: No Error	54: Communication Error (CE1)
1: Overcurrent during Accel (ocA)	55: Communication Error (CE2)
2: Overcurrent during Decel (ocd)	56: Communication Error (CE3)
3: Overcurrent during constant speed (ocn)	57: Communication Error (CE4)
4: Ground Fault (GFF)	58: PC Communication Time Out (CE10)
6: Overcurrent during Stop (ocS)	61: Y-Delta connection Error (ydc)
7: Overvoltage during Accel (ovA)	62: Decel Energy Backup Error (dEb)
8: Overvoltage during Decel (ovd)	63: Slip Error (oS)
9: Overvoltage during constant speed (ovn)	72: Channel 1 (S1~DCM) safety loop error (STL1)
10: Overvoltage during Stop (ovS)	76: Safety Torque Off (STO)
11: Low voltage during Accel (LvA)	77: Channel 2 (S2~DCM) safety loop error (STL2)
12: Low voltage during Decel (Lvd)	78: Internal loop error (STL3)
13: Low voltage during constant speed (Lvn)	79: U Phase over current before run (Aoc)
14: Low voltage during Stop (LvS)	80: V Phase over current before run (boc)
15: Input phase loss (OrP)	81: W Phase over current before run (coc)
16: IGBT Overheat 1 (oH1)	82: U Phase output phase loss (oPL1)
18: Thermister 1 open (tH1o)	83: V Phase output phase loss (oPL2)
21: Drive over-load (oL)	84: W Phase output phase loss (oPL3)
22: Electronics thermal relay protection 1 (EoL1)	87: Drive over load in low frequency (oL3)
23: Electronics thermal relay protection 2 (EoL2)	89: Initial rotor position detection error (roPd)
24: Motor Overheat-PTC (oH3)	121: Internal communication error (CP20)
26: Over Torque 1 (ot1)	123: Internal communication error (CP22)
27: Over Torque 2 (ot2)	124: Internal communication error (CP30)
28: Under current (uc)	126: Internal communication error (CP32)
31: Memory read-out error (cF2)	127: Software version error (CP33)
33: U phase current sensor detection error (cd1)	128: Over-torque 3 (ot3)
34: V phase current sensor detection error (cd2)	129: Over-torque 4 (ot4)
35: W phase current sensor detection error (cd3)	134: Electronics thermal relay 3 protection (EoL3)
36: Clamp current detection error (Hd0)	135: Electronics thermal relay 4 protection (EoL4)
37: Over-current detection error (Hd1)	140: GFF detected when power on (Hd6)
40: Auto tuning error (AuE)	141: GFF occurs before run (b4GFF)
41: PID Feedback loss (AFE)	142: Auto tuning error 1 (DC test stage) (AUE1)
42: PG feedback error (PGF1)	143: Auto tuning error 2 (High frequency test stage) (AUE2)
43: PG feedback loss (PGF2)	144: Auto tuning error 3 (Rotary test stage) (AUE3)
44: PRG feedback stall (PGF3)	
45: PG slip error (PGF4)	
48: Analog current input loss (ACE)	
49: External Fault input (EF)	
50: Emergency Stop (EF1)	
51: External Base Block (bb)	
52: Password Error (Pcod)	

Descriptions of Keypad Functions (continued)	
Descriptions of Keypad Functions	
<b>RUN</b>	<b>RUN Key</b> • Valid only when the source of operation command is from the keypad. • RUN can be pressed even when drive is in process of stopping. • When in "LOCAL" mode, RUN is valid only when the source of operation command is from the keypad (drive default is Auto mode, Local mode can be set with I/O or GS4-KPD only).
<b>STOP/RESET</b>	<b>STOP/RESET Key</b> <i>This key has the highest processing priority in any situation.</i> • When the drive receives a STOP command, whether or not the drive is in operation or stop status, the drive will execute a "STOP" command. • The RESET key can be used to reset the drive after a fault occurs. For those faults that can't be reset by the RESET key, see the fault records after pressing MENU key for details. <i>NOTE: The ability to STOP the drive from the keypad is effective ONLY if the drive is configured to RUN and/or STOP from the keypad. Keypad STOP can be disabled by parameter 00.32, Digital Keypad STOP Function.</i>
<b>ENTER</b>	<b>ENTER Key</b> Press ENTER to go to the next menu level or accept parameter entry. If it is the last level, then press ENTER to execute the command.
<b>MENU</b>	<b>MENU Key</b> Press MENU to return to the Main Menu or cycle through the available menu options.
<b>▲</b>	<b>Direction: Up</b> Press to make the value set on the current menu/parameter higher.
<b>◀/▶</b>	<b>Direction: Left/Down</b> • Press to make the value set on the current menu/parameter lower. • In the menu/text selection mode, the arrows are used for item selection. Long press the MENU key to use the left direction function.
<b>Frequency Setting Dial (Potentiometer)</b>	The dial can be set as the main frequency input. Set Parameter 00-20 or 00-30 to equal '7-Digital Keypad Dial'.

Continued on next page.

Descriptions of LED Functions (continued)	
Descriptions of LED Functions	
<b>RUN</b>	<b>Steady ON:</b> Drive is running. <b>Blinking:</b> Drive is stopping or in base block. <b>Steady OFF:</b> Drive is not running.
<b>FWD</b>	<b>Steady ON:</b> Drive is operating in Forward mode. <b>Blinking:</b> Drive is changing direction. <b>Steady OFF:</b> Drive is operating in Reverse mode.
<b>REV</b>	<b>Steady ON:</b> Drive is operating in Reverse mode. <b>Blinking:</b> Drive is changing direction. <b>Steady OFF:</b> Drive is operating in Forward mode.
<b>STOP</b>	<b>Steady ON:</b> Drive is stopped or in the process of stopping. <b>Blinking:</b> Drive is in standby (run but does not output). <b>Steady OFF:</b> Drive is not currently executing an operational (STOP) command. <i>NOTE: The ability to STOP the drive from the keypad is effective ONLY if the drive is configured to RUN and/or STOP from the keypad. Keypad STOP can be disabled by parameter 00.32, Digital Keypad STOP Function.</i>
<b>PLC</b>	<b>Steady ON:</b> PLC STOP (PLC 2) initiated. <b>Blinking:</b> PLC Run (PLC1) initiated. <b>Steady OFF:</b> No PLC functions implemented (PLC 0).

Continued on next page.

**INTRODUCTION – HOW TO GET STARTED**

Automationdirect.com would like to thank you for your purchase of the Durapulse GS20 AC drive. The GS20 drive is a state-of-the-art, full-featured AC drive. The Quick-Start Guide below will introduce you to many of the GS20 drive features and help you configure the GS20 drive in a minimum amount of time.

STO (Safe Torque Off) / Emergency Stop

The GS20 drive offers Safe Torque Off (STO) functionality, instead of a standard Emergency Stop circuit. STO provides the ability to immediately turn off the output of the GS20 drive in the event of an emergency, without the need for an emergency stop contactor between the drive and motor.

Please see the Control-Circuit Wiring diagrams (page 1) for how to wire the STO circuit. From the factory, the GS20 STO terminals are jumpered and the STO circuitry of the drive is bypassed. STO is recommended for personnel safety.

After wiring the drive (but before applying power), the first thing you should do is press the E-stop button (or otherwise break the safety circuit) and verify that the circuit between the STO1/STO2 terminals and the STO +24V terminal is not connected. If these circuits are open, the STO feature will stop all power from going to the motor and there will be no danger of unexpected movement when you power up the drive.

Powering Up the GS20 Drive

Apply AC line power to the GS20 drive, but don't engage the safety circuit yet (keep the E-stop PB pushed in).

Starting, Stopping, and Controlling the Speed of the GS20 Drive

Out of the box GS20 drives are set to use the keypad buttons to RUN and STOP the drive and vary the drive speed. The drive can also be configured to run from potentiometers, external pushbuttons, Ethernet communication, etc.

Do not attempt to run the motor yet. Certain parameters (especially the motor protection parameters) must be set first.

Configure the Drive

The tables below list those parameters typically used in most applications. You can navigate to any of these parameters through the keypad. (Refer to page 3 for information and instructions for using the Digital Keypad.)

All applications need to configure the parameters in the "Quick Configuration" table. At minimum, you MUST configure these motor parameters before operating the drive:

- 01.02 Motor1 Max Output Voltage (this will typically be either 230V or 460V)
- 05.01 Motor1 Rated Amps (depends on the motor)
- 01.01 Motor1 Max Output Frequency (this will typically be 50Hz or 60Hz)

The main configuration parameters required to get your drive up and running are included in this guide. For more advanced configuration options, please see the User Manual. Your application will dictate which parameters need to be configured. It is NOT necessary to configure every parameter listed in the tables in the User Manual, use only those you need.

Parameter Groups

Group Number	Group Category
00	Drive Config
01	Basic Config
02	Digital I/O Config
03	Analog I/O Config
04	Multi-Step Speed Config
05	Motor Config
06	Protection Config
07	Special Parameters
08	PID Config
09	Communications Config
10	Speed Control Config
11	Advanced Config
13	Macro Config
14	Protection (2) Config

After configuring the minimum settings, you can now engage the safety circuit. The RUN and STOP/RESET buttons should Start and Stop the drive. To adjust the output frequency, press the MENU button until the frequency screen appears. Use the Up and Down arrow buttons to adjust the frequency, the press ENTER to confirm. Press ENTER again to return to the main menu.

**PARAMETER SET UP**

DURAPULSE GS20 AC Drives offer parameter setup from the keypad for some of the most common drives applications. Choose parameters from the table below, then set the applicable parameters for that application as shown.

To Configure Parameters:

From the power up screen:

- 1) Press **MENU** until you see **H 0.00** (this is the actual drive frequency) and press **ENTER**.
- 2) Use the **UP/DWN** arrows to select the parameter group you want and press **ENTER**.
- 3) Use the **UP/DWN** arrows to select the parameter number you want within that group and press **ENTER**.
- 4) Change the value of the parameter using the **UP/DWN** arrows and press **ENTER**.
- 5) Press **MENU** to exit back to the main menu.
- 6) Repeat as needed until all required parameters are configured.



Please refer to the user manual if you need more detailed information about the parameters.

DURAPULSE GS20 Parameter Settings – Quick Configuration*					
Parameter Group	#	Description	Range	Default	User
00	00	GS20 Model ID	Read Only	n/a	
00	01	Displays AC drive rated current	Displays value based on model	n/a	
00	02	Restore to default**	0=No function 1=Parameter write protect 2=Reset to GS2 mode (1 of 2) 5=Reset kWh display to 0 6=Reset PLC 7=Reserved 8=Keypad doesn't respond 9=Reset 50Hz defaults 10=Reset 60Hz defaults 11=Reset 50Hz defaults (keep user config) 12=Reset 60Hz defaults (keep user config) 20=Reset to GS2 mode (2 of 2)	0	
00	06	Firmware Version	Read Only	n/a	
00	10	Control Mode	0=Speed mode 2=Torque mode	0	
00	11	Speed Control Mode	0=VF (IM V/F control) 1=VFPG (IM V/F control + Encoder) 2=SVC (Parameter 05.33 set as IM or PM) 5=FOC (Field Oriented Control)	0	
00	16	Load Selection	0=VT 1=CT	1	
00	20	Frequency Command Source (Auto)	0=Digital keypad 1=Communication RS-485 input 2=External analog input (refer to parm 03.00) 3=External UP/DOWN terminal 4=Pulse input without direction command (refer to parm 10.16 without direction) 7=Digital keypad dial	0	
00	21	Operation Command Source (Auto)	0=Digital keypad 1=External terminals 2=Communication RS-485 input 5=Communication card	0	
00	22	Stop Method	0=Ramp to stop 1=Coast to stop	0	
00	23	Motor Direction Control	0=Enable forward/reverse 1=Disable reverse 2=Disable forward	0	
01	00	Motor 1 Max Frequency	0.00-599.00 Hz	60	
01	01	Motor 1 Base Frequency	0.00-599.00 Hz	60	
01	02	Motor 1 Rated Voltage	110V/230V: 0.0~255.0 460V: 0.0~510.0V	220.0 440.0	
01	09	Startup Frequency	0.00-599.0 Hz	0.5	
01	10	Output Frequency Upper Limit	0.00-599.0 Hz	599.0	
01	11	Output Frequency Lower Limit	0.00-5.99.0 Hz	0.00	
01	12	Acceleration Time 1	P01.45=0: 0.00-600.00 sec P01.45=1: 0.00-6000.00 sec	10.00 10.00	
01	13	Deceleration Time 1	P01.45=0: 0.00-600.00 sec P01.45=1: 0.00-6000.00 sec	10.00 10.00	
01	20	Jog Acceleration Time	P01.45=0: 0.00-600.00 sec P01.45=1: 0.00-6000.00 sec	10.00 10.00	
01	21	Jog Deceleration Time	P01.45=0: 0.00-600.00 sec P01.45=1: 0.00-6000.00 sec	10.00 10.00	
01	22	Jog Frequency	0.00-599.0 Hz	0.5	

\* Assumes default V/Hz mode with no feedback. To change control modes see complete parameter listing in User manual.  
 \*\* Reboot drive after resetting defaults.  
 Note: Drive default is Auto mode and cannot be changed from the keypad. For Local/Hand, use Discrete input configuration settings (P02.00–P02.07) and P00.29–P00.31.  
 (table continued next page)

DURAPULSE GS20 Parameter Settings – Quick Configuration (continued)					
Parameter	Description	Settings	Default	User	
02	00	2-wire / 3-wire Control	0=No function 1=2-wire mode 1, power on for operation control (M1: FWD/STOP, M2: REV/STOP) 2=2-wire mode 2, power on for operation control (M1: RUN/STOP, M2: REV/FWD) 3=3-wire, power on for operation control (M1: RUN, M2: REV/FWD, M3: STOP) 4=2-wire mode 1, fast start up (M1: FWD/STOP, M2: REV/STOP) 5=2-wire mode 2, fast start up (M1: RUN/STOP, M2: REV/FWD) 6=3-wire, fast start up (M1: RUN, M2: REV/FWD, M3: STOP) Note: In fast start up mode, the drive skips detecting IGBT signal and will run immediately. When using fast start up mode: • Terminal output stays in ready status and drive responds to commands immediately. • The output terminal will have higher voltage • If the drive is short circuited an OC error will display when running up	1	
02	01	Multi-function Input Command 1 (FWD/DI1)		0	
02	02	Multi-function Input Command 2 (REV/DI2)		0	
02	03	Multi-function Input Command 3 (DI3)	See "Multi-function Input Selections" on page 5	1	
02	04	Multi-function Input Command 4 (DI4)		2	
02	05	Multi-function Input Command 5 (DI5)		3	
02	06	Multi-function Input Command 6 (DI6)		4	
02	07	Multi-function Input Command 7 (DI7)		0	
02	13	Multi-function Output 1 (R1)		11	
02	16	Multi-function Output 2 (DO1)	See "Multi-function Output Selections" on page 5	0	
02	17	Multi-function Output 3 (DO2)		0	
03	00	Analog Input Selection (AI1)	See "AI Multi-function Input Selections" on page 5	1	
03	01	Analog Input Selection (AI2)		0	
03	20	Multi-function Output (AO1)	See "AO1 Multi-function Output Selections" on page 5	0	
03	29	AI2 terminal input selection	0=4-20 mA 1=0-10 V 2=0-20 mA	0	
04	to 14	Multi-step Speed Frequency 1–15	0.00-599.00 Hz	0.00	
05	00	Motor Parameter Auto-tuning	0=No function 1=Dynamic test for induction motor (IM) 2=Static test for induction motor (IM) 5=Rolling auto-tuning for PM (IPM /SPM) 6=Simple rolling auto-tuning for induction motor (IM) 12=FOC sensorless inertia estimation 13=High frequency stall test for PM	0	
05	01	Motor 1 Full Load Amps (FLA)	10-120% of drive rated current	###	
05	03	Motor 1 Rated RPM	0-65535	1710	
05	04	Motor 1 Number of poles	2-20	4	
06	06	Over-torque Detection Selection (Motor 1)	0=No function 1=Continue operation after over-torque detection during constant speed operation 2=Stop after over-torque detection during constant speed operation 3=Continue operation after over-torque detection during RUN 4=Stop after over-torque detection during RUN	0	
06	07	Over-torque Detection Level (Motor 1)	10-250% (100% corresponds to the rated current of the drive)	120	
06	08	Over-torque Detection Time (Motor 1)	0.1-60.0 seconds	0.1	
06	13	Motor 1 Electronic Thermal Overload Relay	0=Inverter motor (with external forced cooling) 1=Standard motor (motor with fan on the shaft) 2=Disabled	2	
06	14	Motor 1 Electronic Thermal Relay Time	30.0-600.0	60	
06	55	Drive Derating Method	0=Constant rated current and limit carrier wave by load current and temperature 1=Constant carrier frequency and limit load current by setting carrier wave 2=Constant rated current (same as setting 0) but close current limit	0	
07	10	Restart after fault action	0=Stop operation 1=Speed tracking by current speed 2=Speed tracking by minimum output frequency	0	

(table continued next page)

DURAPULSE GS20 Parameter Settings – Quick Configuration (continued)					
Parameter Group	#	Description	Range	Default	User
07	11	Number of times of restart after fault	0-10	0	
07	19	Fan cooling control	0=Fan is always ON 1=Fan is OFF after the AC motor drive stops for one minute 2=Fan is ON when the AC motor drive runs, fan is OFF when the AC motor drive stops 3=Fan turns ON when temperature (IGBT) reaches approximately 600°C	3	
08	00	Terminal selection of PID feedback	0=No function 1=Negative PID feedback: by analog input (P03.00, P03.01) 2=Negative PID feedback: by single-phase input (DI7), without direction (P10.16=5) 4=Positive PID feedback: by analog input (P03.00, P03.01) 5=Positive PID feedback: by single-phase input (DI7), without direction (P10.16=5) 7=Negative PID feedback: by communication protocols 8=Positive PID feedback: by communication protocols	0	
08	01	Proportional gain (P)	0.0-1000.0 (When P08.23 bit 1=0) 0.00-100.00 (When P08.23 bit 1=1)	1.00	
08	02	Integral time (I)	0.00-100.00 sec.	1.00	
08	03	Differential time (D)	0.00-1.00 sec.	0.00	
08	04	Upper limit of integral control	0.0-100.0%	100.0	
08	05	PID output command limit (positive limit)	0.0-110.0%	100.0	
08	06	PID feedback value by communication protocol	-200.00-200.00%	0.00	
08	07	PID delay time	0.0-2.5 sec.	0.0	
08	08	Feedback signal detection time	0.0-3600.0 sec.	0.0	
08	09	Feedback signal fault treatment	0=Warn and continue operation 1=Fault and ramp to stop 2=Fault and coast to stop 3=Warn and operate at last frequency	0	
08	65	PID target value source	0=Frequency command (P00.20, P00.30) 1=P08.66 setting 2=RS-485 communication input 3=External analog input (refer to P03.00, P03.01) 6=Communication card 7=Digital keypad potentiometer dial (GS20 only)	0	
13	00	Application Selection	00=Disabled 01=User parameter 02=Compressor 03=Fan 04=Pump 05=Conveyor 06=Machine tool 07=Packing 08=Textiles	0	

Multi-function Output Selections		
0=No function 1=Indication during RUN 2=Operation speed reached 3=Desired frequency reached 1 (P02.22) 4=Desired frequency reached 2 (P02.24) 5=Zero speed (Frequency command) 6=Zero speed including STOP 7=Over-torque 1 (P06.06-06.08) 8=Over-torque 2 (P06.09-06.11) 9=Drive is ready 10=Low voltage warning (Lv) (P06.00) 11=Malfunction indication 13=Overheat warning (P06.15) 14=Software brake signal indicator (P07.00) 15=PID feedback error (P08.13, P08.14) 16=Slip error (oSL) 17=Count value reached, does not return to 0 (P02.20) 18=Count value reached, return to 0 (P02.19)	19=External interrupt B.B. input (Base Block) 20=Warning output 21=Over-voltage 22=Over-current stall prevention 23=Over-voltage stall prevention 24=Operation mode 25=Forward command 26=Reverse command 29=Output when frequency ≥ P02.34 30=Output when frequency < P02.34 31=Y-connection for the motor coil 32=Δ-connection for the motor coil 33=Zero speed (actual output frequency) 34=Zero speed including STOP (actual output frequency) 35=Error output selection 1 (P06.23) 36=Error output selection 2 (P06.24) 37=Error output selection 3 (P06.25) 38=Error output selection 4 (P06.26)	40=Speed reached (including STOP) 42=Crane function 43=Motor speed detection 44=Low current output (use with P06.71-06.73) 45=UVW output electromagnetic valve switch 46=Master dEb output 51=Analog output control for RS-485 interface 52=Output control for communication cards 53=Fire mode indication 66=SO output logic A 67=Analog input level reached 68=SO output logic B 73=Over-torque 3 74=Over-torque 4 75=Forward RUN status 76=Reverse RUN status

AI Multi-function Input Selections		
0=No function 1=Frequency command 2=Torque command (torque limit under speed mode) 3=Torque compensation command	4=PID target value 5=PID feedback signal 6=Thermistor (PTC) input value 7=Positive torque limit 8=Negative torque limit	9=Regenerative torque limit 10=Positive / negative torque limit 11=PT100 thermistor input value 12=Auxiliary frequency input 13=PID compensation value

AO1 Multi-function Output Selections		
0=Output frequency (Hz) 1=Frequency command (Hz) 2=Motor speed (Hz) 3=Output current (rms) 4=Output voltage 5=DC bus voltage 6=Power factor 7=Power	8=Output torque 9=A11 10=A12 12=Iq current command 13=Iq feedback value 14=Id current command 15=Id feedback value	16=Vq-axis voltage command 17=Vd-axis voltage command 18=Torque command 19=PG2 (DI7) frequency command 21=RS-485 analog output 22=Communication card analog output 23=Constant voltage output

**OPTIONAL CONFIGURATION SETTING:**

GS2 mode is an optional setting for users who want the drive to operate in the legacy GS2 parameter configuration. This mode changes the entire parameter structure of the drive. See the GS20 User Manual Appendix G for more details.

**ENTERING AND EXITING “GS2” MODE**

GS20 drives that have an equivalent GS2 model (same power and HP rating) have the option of being operated in “GS2 Mode”. This allows you to use the new drive in exactly the same role as an older GS2 drive that needs to be replaced, or in conjunction with existing GS2 drives.

Note that all drives will come factory standard with GS20 mode as the default setting.

Enter GS2 Mode

Note: To enter GS2 mode, parameters cannot be locked or set to read only, and the PLC must be disabled. If any of these requirements are not met, you will be unable to set 00.02 to 20.

- 1) Set parameter 00.02=2, to reset to GS2 mode (1st parameter) and press ENTER.
- 2) Set parameter 00.02=20 to reset to GS2 mode (2nd parameter) and press ENTER.
- 3) Reboot the drive by cycling power.
- 4) Configure GS2 parameters.

Exit GS2 Mode

- 1) Set parameter 09.08=20 to reset to GS20 mode (parameters will reset). Press ENTER.
- 2) Reboot the drive by cycling power.
- 3) Configure GS20 parameters per the tables above and in the GS20 User Manual.

Multi-function Input Selections		
0=No function 1=Multi-step speed command 1 / multi-step position command 1 2=Multi-step speed command 2 / multi-step position command 2 3=Multi-step speed command 3 / multi-step position command 3 4=Multi-step speed command 4 / multi-step position command 4 5=Reset 6=JOG [by external control or GS4-KPD (optional)] 7=Acceleration / deceleration speed inhibit 8=1st and 2nd acceleration / deceleration time selection 9=3rd and 4th acceleration / deceleration time selection 10=External Fault (EF) Input (P07.20) 11=Base Block (B.B.) input from external source 12=Output stop 13=Cancel the setting of auto-acceleration / auto-deceleration time	15=Rotating speed command from AI1 16=Rotating speed command from AI2 18=Force to stop (P07.20) 19=Digital up command 20=Digital down command 21=PID function disabled 22=Clear the counter 23=Input the counter value (DI6) 24=FWD JOG command 25=REV JOG command 26=TQC / Field Oriented Control (FOC) mode selection 27=ASR1 / ASR2 selection 28=Emergency stop (EF1) 29=Signal confirmation for Y-connection 30=Signal confirmation for Δ-connection 31=High torque bias (P11.30) 32=Middle torque bias (P11.31) 33=Low torque bias (P11.32) 38=Disable writing EEPROM function 39=Torque command direction 40=Force coasting to stop 41=HAND switch	42=AUTO switch 48=Mechanical gear ratio switch 49=Enable drive 50=Slave dEb action to execute 51=Selection for PLC mode bit 0 52=Selection for PLC mode bit 1 56=Local / Remote selection 58=Enable fire mode (with RUN command) 59=Enable fire mode (without RUN command) 70=Force auxiliary frequency return to 0 71=Disable PID function, force PID output return to 0 72=Disable PID function, retain the output value before disabled 73=Force PID integral gain return to 0, disable integral 74=Reverse PID feedback 81=Simple positioning zero point position signal input 82=OOB loading balance detection 83=Multi-motor (IM) selection bit 0 84=Multi-motor (IM) selection bit 1

**COOLING AND HEAT DISSIPATION**

Model Number	Airflow Rate for Cooling		Power Dissipation (Watts)		
	Flow Rate (cfm)	Flow Rate (m <sup>3</sup> /hr)	Loss External (Heat sink)	Internal	Total
GS21-10P2	0.0	0.0	8.0	10.0	18.0
GS21-10P5			14.2	13.1	27.3
GS21-11P0	16.0	27.2	29.1	23.9	53.0
GS21-20P2	0.0	0.0	8.0	10.3	18.3
GS21-20P5			16.3	14.5	30.8
GS21-21P0	16.0	27.2	29.1	20.1	49.2
GS21-22P0			29.1	23.9	53.0
GS21-23P0	53.7	91.2	70.0	35	105
GS23-2010			244.5	79.6	324.1
GS23-2015	67.9	115.2	374.2	86.2	460.4
GS23-2020			492.0	198.2	690.2
GS23-20P2	0.0	0.0	8.6	10.0	18.6
GS23-20P5			16.5	12.6	29.1
GS23-21P0	10.0	16.99	31.0	13.2	44.2
GS23-22P0			50.1	24.2	74.3
GS23-23P0	16.0	27.2	76.0	30.7	106.7
GS23-25P0			108.2	40.1	148.3
GS23-27P5	23.4	39.7	192.8	53.3	246.1
GS23-4010			164.7	55.8	220.5
GS23-4015	53.7	91.2	234.5	69.8	304.3
GS23-4020			319.8	74.3	394.1
GS23-4025	67.9	115.2	423.5	181.6	605.1
GS23-4030			501.1	200.3	701.4
GS23-40P5	10.0	16.99	17.6	11.1	28.7
GS23-41P0			30.5	17.8	48.3
GS23-42P0	16.0	27.2	45.9	21.7	67.6
GS23-43P0			60.6	22.8	83.4
GS23-45P0	23.4	39.7	93.1	42	135.1
GS23-47P5			132.8	39.5	172.3
GS23-5010	0.0	0.0	108.4	51	159.4
GS23-51P0			23.5	12.5	36
GS23-52P0	10.0	16.99	38.1	19	57.1
GS23-53P0	16.0	27.2	56.6	22.2	68.8
GS23-55P0			76.1	30	106.1
GS23-57P5	23.4	39.7	93.9	37	130.9

- External Flow Rate is across the heat sink.
- Internal Flow Rate is through the chassis.
- Published flow rates are the result of active cooling using fans, factory installed in the drive.
- Unpublished flow rates ( - ) are the result of passive cooling in drives without factory installed fans.
- The required airflow shown in the chart is for installing a single GS20 drive in a confined space.
- When installing multiple GS20 drives, the required air volume would be the required air volume for a single GS20 drive multiplied by the number of GS20 drives.
- When calculating power dissipation (Watt Loss), use the Total value. Heat dissipation shown in the chart is for installing a single GS20 drive in a confined space.
- When installing multiple drives, the volume of heat/power dissipation should be the heat/power dissipated by a single GS20 drive multiplied by the number of GS20 drives.
- Heat dissipation for each model is calculated by rated voltage, current and default carrier frequency.

**ENVIRONMENT FOR OPERATION, STORAGE, AND TRANSPORTATION**

DO NOT expose the GS20 drive to environments that contain dust, direct sunlight, corrosive/inflammable gases, high humidity, liquids, or high vibration. The salt in the air must be less than 0.01 mg/cm<sup>2</sup> throughout the year.

<b>Environment</b>	Installation Location	IEC60364-1/IEC60664-1 Pollution degree 2, Indoor use only			
	Surrounding Temperature	Storage:	-40°C to +85°C	Transportation: -20°C to +70°C	
		No condensation, non-frozen			
	Rated Humidity	Operation:	Max. 90%	Storage/Transportation: Max. 95%	
		No condensed water			
	Air Pressure	Operation/Storage:	86 to 106 kPa	Transportation: 70 to 106 kPa	
Pollution Level	IEC60721-3				
	Operation:	Class 3C2; Class 3S2	Storage:	Class 2C2; Class 2S2	
	Transportation:		Class 1C2; Class 1S2		
Altitude	Operation	If the GS20 drive is installed at altitudes of 0~1000m, follow normal operation restriction. If installed at altitudes of 1000~2000m, decrease 1% of rated current or lower 0.5°C of temperature for every 100m increase in altitude. Maximum altitude for Corner Grounded is 2000m. Contact ADC for more information if you need to use this motor drive at an altitude of 2000m or higher.			
<b>Package Drop</b>	Storage	ISTA procedure 1A (according to weight) IEC60068-2-31			
	Transportation				
<b>Vibration</b>	Operating	1.0mm, peak-to-peak value range from 2Hz to 13.2 Hz; 0.7G~1.0G range from 13.2Hz to 55Hz; 2.0G range from 55Hz to 512 Hz. Comply with IEC 60068-2-6.			
	Non-operating	2.5 G peak, 5Hz~2kHz: 0.015" maximum displacement.			
<b>Impact</b>	Operating	IEC/EN60068-2-27: 15G, 11ms			
	Non-operating	30G			
<b>Protection Level</b>		IP40 - main unit IP20 - wiring area (main circuit terminals and control terminals (all frame types), and the vent near the capacitor on frame C, D, E, and F types).			



To prevent personal injury, please make sure that the case and wiring are installed according to these instructions. The figures in these instructions are only for reference. They may be slightly different from the one you have, but it will not affect your customer rights.



These installation instructions may be revised without prior notice. The most recent edition can be downloaded from the AutomationDirect web site at any time: <http://www.automationdirect.com/static/manuals/index.html>.

**MINIMUM MOUNTING CLEARANCES**

When installing your GS20 drive, please keep the following in mind:

- Prevent fiber particles, scraps of paper, shredded wood, saw dust, metal particles, etc., from adhering to the heat sink.
- Install the AC motor drive in a metal cabinet. When installing one drive below another one, use a metal separation between the AC motor drives to prevent mutual heating and to prevent the risk of accidental fire.
- Install the AC motor drive in Pollution Degree 2 environments only: normally only nonconductive pollution occurs and temporary conductivity caused by condensation is expected.

← (BLUE ARROW) INFLOW

← (RED ARROW) OUTFLOW

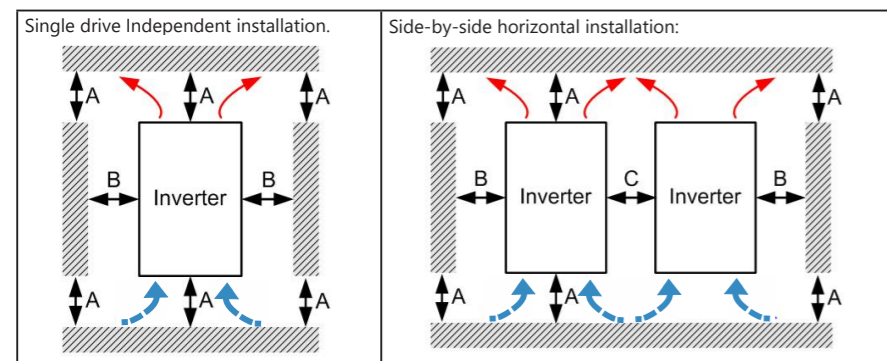

Installation Method	A (mm)	B (mm)	C (mm)	Operation Temperature	
				Max (w/out derating)	Max (Derating)
Single drive installation	50	30	-	50	60
Side-by-side horizontal installation	50	30	30	50	60
Zero stack installation	50	30	0	40	50

**DIMENSION DIAGRAMS**

**GS20 FRAME A**

Units = mm [in]

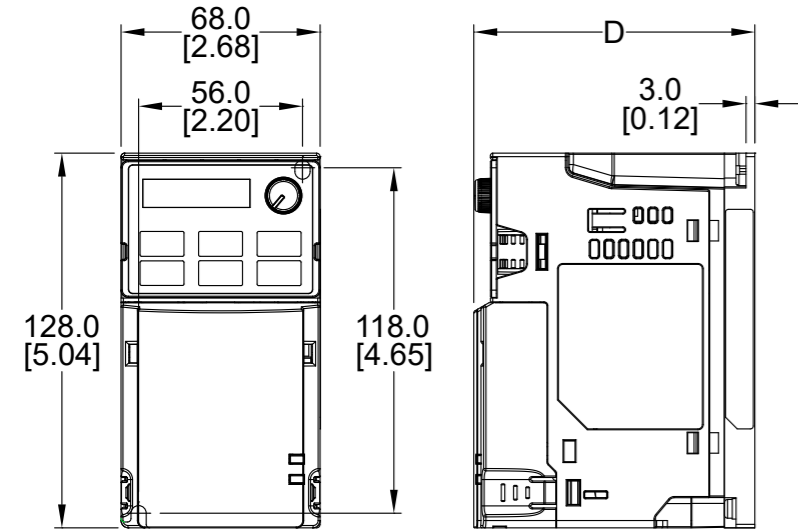

Models by Frame Size		
Model	Frame	D mm [in]
GS21-10P2	A1	96.0 [3.78]
GS21-20P2		
GS23-20P2		
GS23-20P5	A2	110.0 [4.33]
GS21-10P5	A3	125.0 [4.92]
GS21-20P5		
GS23-40P5	A4	129.0 [5.08]
GS23-21P0	A5	143.0 [5.63]
GS23-41P0		
GS23-51P0		

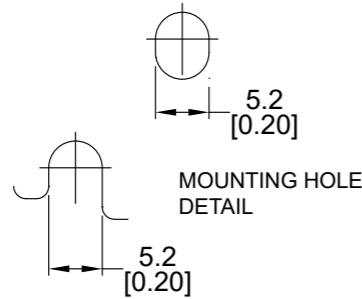
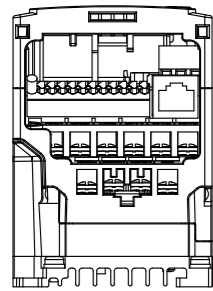

**GS20 FRAME B**

Units = mm [in]

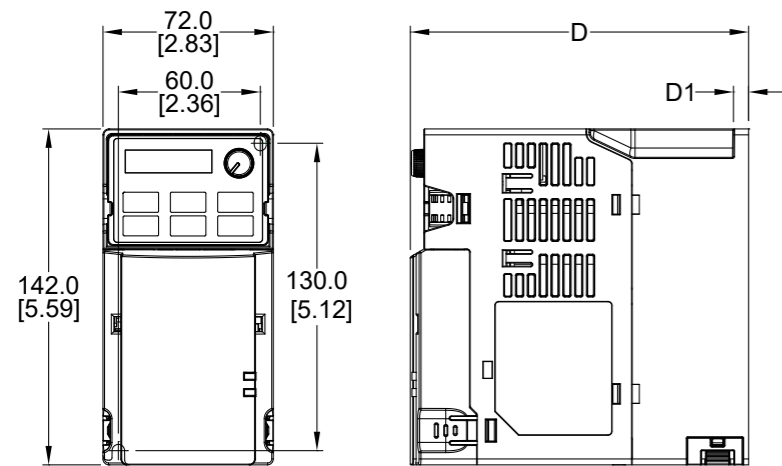

Models by Frame Size			
Model	Frame	D mm [in]	D1 mm [in]
GS23-22P0	B1	143.0 [5.63]	6.4 [0.25]
GS23-42P0			
GS23-52P0			
GS21-21P0	B2	143.0 [5.63]	3.0 [0.12]

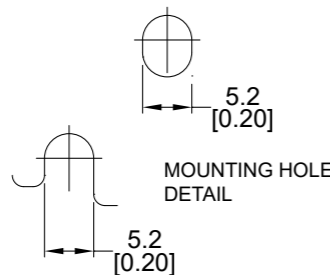
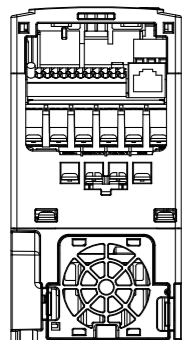

**GS20 FRAME C**

Units = mm [in]

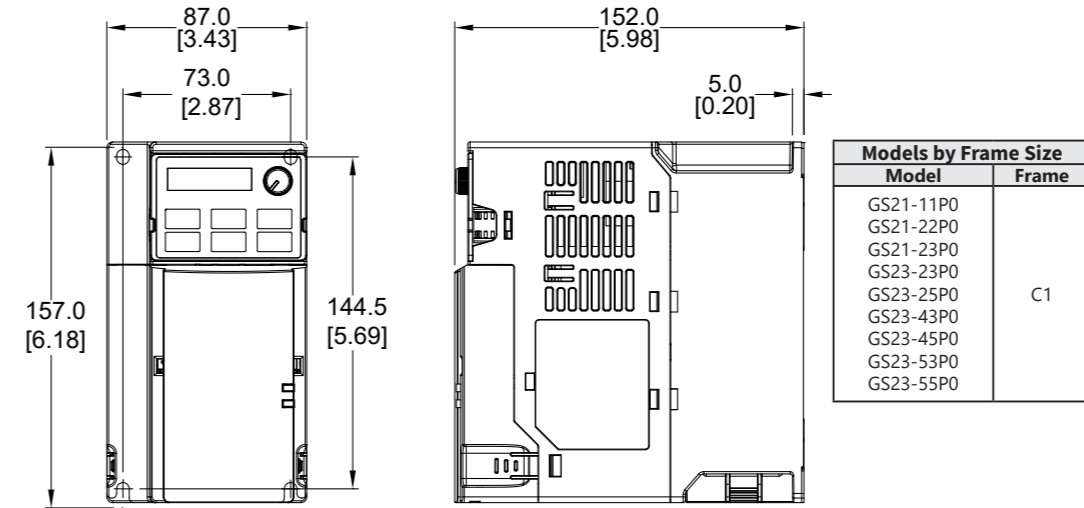

Models by Frame Size	
Model	Frame
GS21-11P0	C1
GS21-22P0	
GS21-23P0	
GS23-23P0	
GS23-25P0	
GS23-43P0	
GS23-45P0	
GS23-53P0	
GS23-55P0	

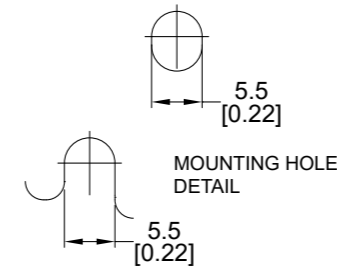
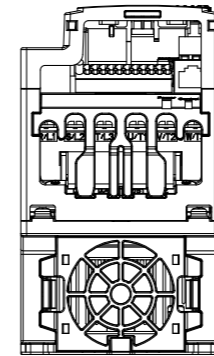

**GS20 FRAME D**

Units = mm [in]

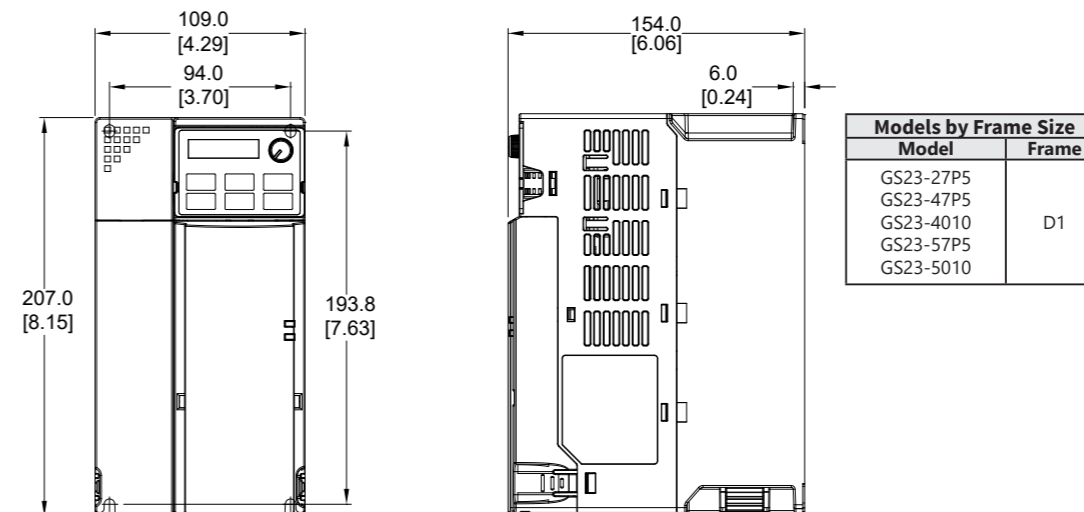

Models by Frame Size	
Model	Frame
GS23-27P5	D1
GS23-47P5	
GS23-4010	
GS23-57P5	
GS23-5010	

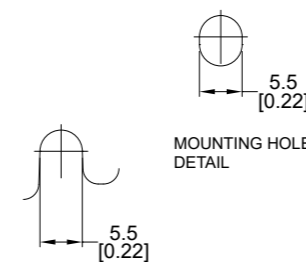
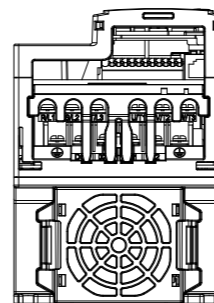

**GS20 FRAME E**

Units = mm [in]

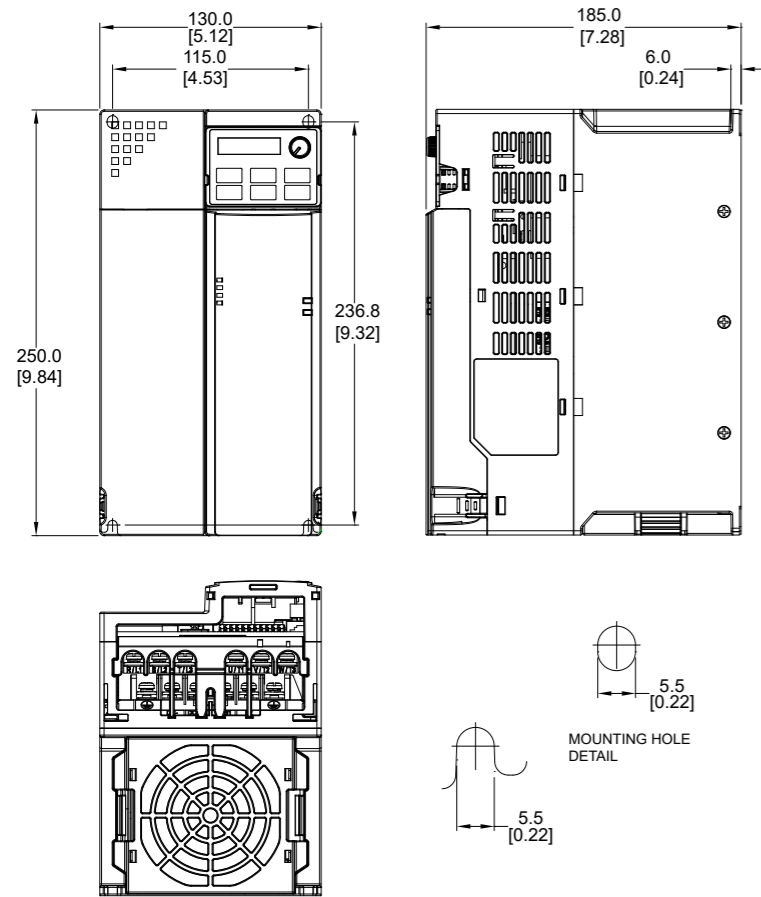

Models by Frame Size	
Model	Frame
GS23-2010	E1
GS23-2015	
GS23-4015	
GS23-4020	

**GS20 FRAME F**

Units = mm [in]

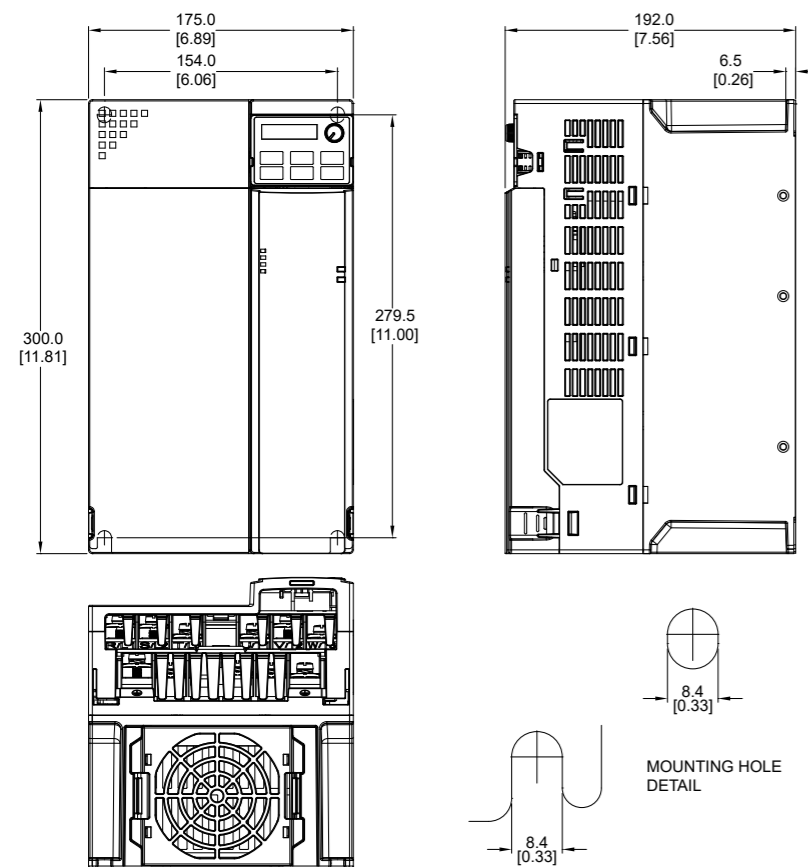

Models by Frame Size	
Model	Frame
GS23-2020	F1
GS23-4025	
GS23-4030	

**NEMA 1 CONDUIT BOXES**

The GS20 drives can optionally be fitted to a NEMA1 conduit box, with one available box per frame size. The dimensional diagrams below show how the box will change the dimensions of the GS20 unit.

