

SMP10

Pyranometer



Guarantee

This equipment is guaranteed against defects in materials and workmanship. We will repair or replace products which prove to be defective during the guarantee period as detailed on your invoice, provided they are returned to us prepaid. The guarantee will not apply to:

- Equipment which has been modified or altered in any way without the written permission of Campbell Scientific
- Batteries
- Any product which has been subjected to misuse, neglect, acts of God or damage in transit.

Campbell Scientific will return guaranteed equipment by surface carrier prepaid. Campbell Scientific will not reimburse the claimant for costs incurred in removing and/or reinstalling equipment. This guarantee and the Company's obligation thereunder is in lieu of all other guarantees, expressed or implied, including those of suitability and fitness for a particular purpose. Campbell Scientific is not liable for consequential damage.

Please inform us before returning equipment and obtain a Repair Reference Number whether the repair is under guarantee or not. Please state the faults as clearly as possible, and if the product is out of the guarantee period it should be accompanied by a purchase order. Quotations for repairs can be given on request. It is the policy of Campbell Scientific to protect the health of its employees and provide a safe working environment, in support of this policy a "Declaration of Hazardous Material and Decontamination" form will be issued for completion.

When returning equipment, the Repair Reference Number must be clearly marked on the outside of the package. Complete the "Declaration of Hazardous Material and Decontamination" form and ensure a completed copy is returned with your goods. Please note your Repair may not be processed if you do not include a copy of this form and Campbell Scientific Ltd reserves the right to return goods at the customers' expense.

Note that goods sent air freight are subject to Customs clearance fees which Campbell Scientific will charge to customers. In many cases, these charges are greater than the cost of the repair.



Campbell Scientific Ltd,
80 Hathern Road,
Shepshed, Loughborough, LE12 9GX, UK
Tel: +44 (0) 1509 601141
Fax: +44 (0) 1509 270924
Email: support@campbellsci.co.uk
www.campbellsci.co.uk

PLEASE READ FIRST

About this manual

Please note that this manual was originally produced by Campbell Scientific Inc. primarily for the North American market. Some spellings, weights and measures may reflect this origin.

Some useful conversion factors:

Area: 1 in ² (square inch) = 645 mm ²	Mass: 1 oz. (ounce) = 28.35 g 1 lb (pound weight) = 0.454 kg
Length: 1 in. (inch) = 25.4 mm 1 ft (foot) = 304.8 mm 1 yard = 0.914 m 1 mile = 1.609 km	Pressure: 1 psi (lb/in ²) = 68.95 mb
	Volume: 1 UK pint = 568.3 ml 1 UK gallon = 4.546 litres 1 US gallon = 3.785 litres

In addition, while most of the information in the manual is correct for all countries, certain information is specific to the North American market and so may not be applicable to European users.

Differences include the U.S standard external power supply details where some information (for example the AC transformer input voltage) will not be applicable for British/European use. *Please note, however, that when a power supply adapter is ordered it will be suitable for use in your country.*

Reference to some radio transmitters, digital cell phones and aerials may also not be applicable according to your locality.

Some brackets, shields and enclosure options, including wiring, are not sold as standard items in the European market; in some cases alternatives are offered. Details of the alternatives will be covered in separate manuals.

Part numbers prefixed with a “#” symbol are special order parts for use with non-EU variants or for special installations. Please quote the full part number with the # when ordering.

Recycling information



At the end of this product's life it should not be put in commercial or domestic refuse but sent for recycling. Any batteries contained within the product or used during the products life should be removed from the product and also be sent to an appropriate recycling facility.

Campbell Scientific Ltd can advise on the recycling of the equipment and in some cases arrange collection and the correct disposal of it, although charges may apply for some items or territories.

For further advice or support, please contact Campbell Scientific Ltd, or your local agent.



Campbell Scientific Ltd, 80 Hathern Road, Shepshed, Loughborough, LE12 9GX,
UK Tel: +44 (0) 1509 601141 Fax: +44 (0) 1509 270924
Email: support@campbellsci.co.uk
www.campbellsci.co.uk

Safety

DANGER — MANY HAZARDS ARE ASSOCIATED WITH INSTALLING, USING, MAINTAINING, AND WORKING ON OR AROUND **TRIPODS, TOWERS, AND ANY ATTACHMENTS TO TRIPODS AND TOWERS SUCH AS SENSORS, CROSSARMS, ENCLOSURES, ANTENNAS, ETC.** FAILURE TO PROPERLY AND COMPLETELY ASSEMBLE, INSTALL, OPERATE, USE, AND MAINTAIN TRIPODS, TOWERS, AND ATTACHMENTS, AND FAILURE TO HEED WARNINGS, INCREASES THE RISK OF DEATH, ACCIDENT, SERIOUS INJURY, PROPERTY DAMAGE, AND PRODUCT FAILURE. TAKE ALL REASONABLE PRECAUTIONS TO AVOID THESE HAZARDS. CHECK WITH YOUR ORGANIZATION'S SAFETY COORDINATOR (OR POLICY) FOR PROCEDURES AND REQUIRED PROTECTIVE EQUIPMENT PRIOR TO PERFORMING ANY WORK.

Use tripods, towers, and attachments to tripods and towers only for purposes for which they are designed. Do not exceed design limits. Be familiar and comply with all instructions provided in product manuals. Manuals are available at www.campbellsci.eu or by telephoning +44(0) 1509 828 888 (UK). You are responsible for conformance with governing codes and regulations, including safety regulations, and the integrity and location of structures or land to which towers, tripods, and any attachments are attached. Installation sites should be evaluated and approved by a qualified engineer. If questions or concerns arise regarding installation, use, or maintenance of tripods, towers, attachments, or electrical connections, consult with a licensed and qualified engineer or electrician.

General

- Prior to performing site or installation work, obtain required approvals and permits. Comply with all governing structure-height regulations, such as those of the FAA in the USA.
- Use only qualified personnel for installation, use, and maintenance of tripods and towers, and any attachments to tripods and towers. The use of licensed and qualified contractors is highly recommended.
- Read all applicable instructions carefully and understand procedures thoroughly before beginning work.
- Wear a **hardhat** and **eye protection**, and take **other appropriate safety precautions** while working on or around tripods and towers.
- **Do not climb** tripods or towers at any time, and prohibit climbing by other persons. Take reasonable precautions to secure tripod and tower sites from trespassers.
- Use only manufacturer recommended parts, materials, and tools.

Utility and Electrical

- **You can be killed** or sustain serious bodily injury if the tripod, tower, or attachments you are installing, constructing, using, or maintaining, or a tool, stake, or anchor, come in **contact with overhead or underground utility lines.**
- Maintain a distance of at least one-and-one-half times structure height, or 20 feet, or the distance required by applicable law, **whichever is greater**, between overhead utility lines and the structure (tripod, tower, attachments, or tools).
- Prior to performing site or installation work, inform all utility companies and have all underground utilities marked.
- Comply with all electrical codes. Electrical equipment and related grounding devices should be installed by a licensed and qualified electrician.

Elevated Work and Weather

- Exercise extreme caution when performing elevated work.
- Use appropriate equipment and safety practices.
- During installation and maintenance, keep tower and tripod sites clear of un-trained or non-essential personnel. Take precautions to prevent elevated tools and objects from dropping.
- Do not perform any work in inclement weather, including wind, rain, snow, lightning, etc.

Maintenance

- Periodically (at least yearly) check for wear and damage, including corrosion, stress cracks, frayed cables, loose cable clamps, cable tightness, etc. and take necessary corrective actions.
- Periodically (at least yearly) check electrical ground connections.

WHILE EVERY ATTEMPT IS MADE TO EMBODY THE HIGHEST DEGREE OF SAFETY IN ALL CAMPBELL SCIENTIFIC PRODUCTS, THE CUSTOMER ASSUMES ALL RISK FROM ANY INJURY RESULTING FROM IMPROPER INSTALLATION, USE, OR MAINTENANCE OF TRIPODS, TOWERS, OR ATTACHMENTS TO TRIPODS AND TOWERS SUCH AS SENSORS, CROSSARMS, ENCLOSURES, ANTENNAS, ETC.

Table of contents

1. Introduction	1
2. Specifications	1
3. Siting	2
4. Mounting procedure	2
5. Wiring	4
6. Register map	5
7. RS-485 programming	6
8. Analogue programming	6
9. Example programs	7
10. Maintenance and troubleshooting	10

1. Introduction

The SMP10 pyranometer, manufactured by Kipp & Zonen and cabled by Campbell Scientific, measures solar radiation with a high-quality blackened thermopile protected by two glass domes. Its flat spectral sensitivity makes it ideal for applications in natural sunlight, under plant canopies, and in greenhouses or buildings. Communications to on-site RTUs, SCADA systems, or other data acquisition systems are simplified with the industry-standard Modbus RTU communications protocol. Typical uses include environmental monitoring, solar resource assessment, and solar power performance applications.

Typically, this pyranometer is oriented perpendicular to the Earth's surface to measure global horizontal irradiance (GH). Diffuse sky radiation can also be measured with the use of a shade mechanism.

2. Specifications

ISO 9060:2018 classification:	class A (secondary standard)
Output:	Modbus over 2-wire RS-485 or 0 to 1 V
Analogue output range:	0 to 1600 W/m ²
Modbus output range:	-400 to 4000 W/m ²
Zero offset A:	< 7 W/m ²
Zero offset B:	< 2 W/m ²
Spectral range:	285 to 2800 nm
Operating temperature range:	-40 to 80 °C
Temperature response:	< 1% (-20 to 50 °C); < 2% (-40 to 70 °C)
Operating voltage range:	5 to 30 VDC
Power consumption:	< 55 mW at 12 VDC
Weight without cable:	0.6 kg (1.3 lb)

3. Siting

The solar radiation sensor is usually installed horizontally, but can also be installed at any angle including an inverted position. Site the sensor to allow easy access for maintenance while ideally avoiding any obstructions or reflections above the plane of the sensing element. It is important to mount the sensor such that a shadow or a reflection will not be cast on it at any time. If this is not possible, try to choose a site where any obstruction over the azimuth range between earliest sunrise and latest sunset has an elevation not exceeding 5°. Diffuse solar radiation is less influenced by obstructions near the horizon. The sensor should be mounted with the cable pointing towards the nearest magnetic pole. For example, in the northern hemisphere, point the cable toward the North Pole.

4. Mounting procedure

Required tools:

- Diopter
 - Solar compass
 - 8 mm (5/16-inch) open-end wrench for U-bolt nuts
1. On a level surface, level the solar radiation sensor using the levelling feet on the sensor. Alternatively, remove the sensor levelling feet to allow it to be mounted directly to the mounting bracket.
 2. Secure the solar radiation sensor to the mounting bracket. The blue dots in the following figure indicate the mounting holes used for this pyranometer.

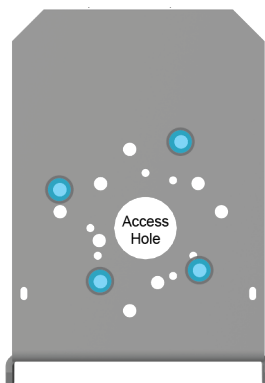

- Using a diopter in combination with a solar compass, install and orient the crossarm on the tripod or the mast. If installing the mounting bracket on a vertical pole, ensure the pole is truly vertical.
- Secure the mounting bracket to the crossarm or vertical pole using the hardware included with the mounting bracket. The CM255 uses one U-bolt, nuts, flat washers, and lock washers to mount the bracket, as shown in the following figure.

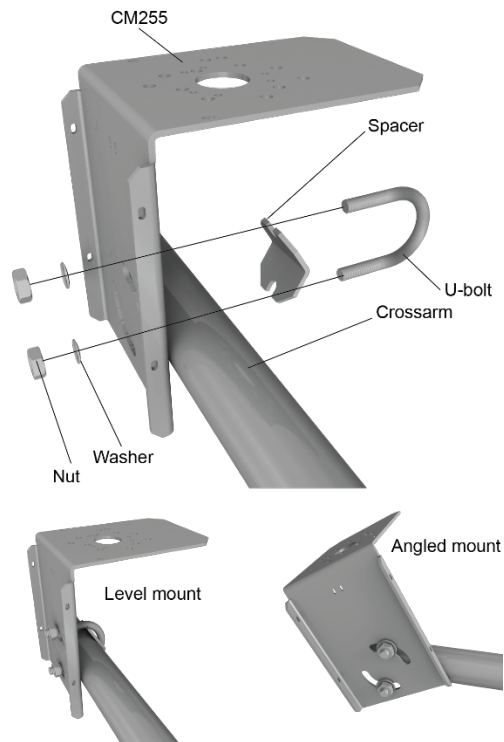

- For the CM255LS bracket, use the two set screws to secure the bracket to the crossarm or pole as shown in the following figure. For pyranometers mounted horizontally, ensure the mounting bracket is horizontal in two dimensions. For pyranometers mounted at an angle, set the mounting bracket angle to the desired angle prior to tightening the mounting hardware.

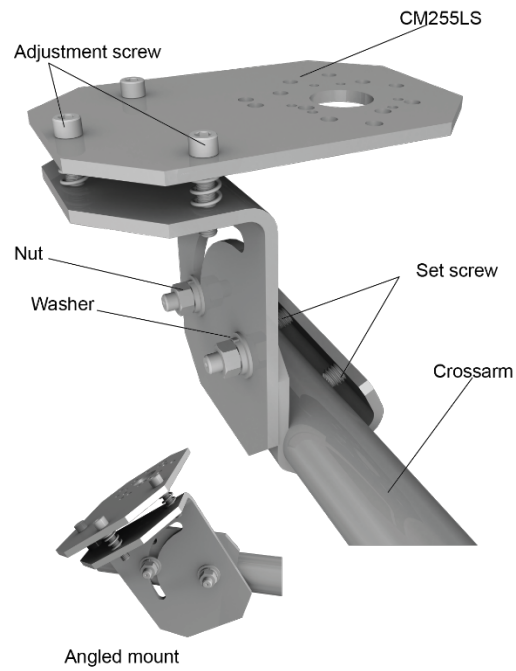

- Verify mounting hardware is firmly tightened, and that the mounting bracket is at the desired angle. The CM255LS includes levelling bolts for additional adjustment.

5. Wiring

Table 5-1 (p. 4) provides RS-485 wiring and Table 5-2 (p. 5) provides analogue wiring.

Wire colour	Pin-out	Function	Data logger connection ¹	MeteoPV connection
Grey	5	RS485A+	C (odd)	A-
Yellow	4	RS485B-	C (even)	B+
White	7	Power in (12 V)	12V	12V
Black	8	Power ground	G	G
Blue	2	Ground	⊥ (analogue ground)	⊥ (analogue ground)

¹ Assumes the sensor directly connects to the data logger.

Wire colour	Pin-out	Function	Differential data logger connection	Single-ended data logger connection
Green	3	Pyranometer Signal High	U configured for differential input ¹ , DIFF H (differential high, analogue-voltage input)	U configured for single-ended analogue input ¹ , SE (single-ended, analogue-voltage input)
Brown	6	Pyranometer Signal Reference	U configured for differential input ¹ , DIFF L (differential low, analogue-voltage input)	⏏ (analogue ground)
Blue	2	Ground	⏏ (analogue ground)	⏏ (analogue ground)

¹ U channels are automatically configured by the measurement instruction.

6. Register map

[RS-485 Register Map](#) (p. 5) provides the register map for the most commonly used values. A comprehensive register map is available in the Kipp and Zonen manual.

Starting register number	Register count	Data format	Label	Units	Description
4	1	unsigned integer	Status		Device Status flags
5	1	signed integer	Range		Range and scale factor sensor data (determines number of decimal places)
6	1	signed integer	Sensor1	W/m ²	Temperature compensated net radiation
7	1	signed integer	RawData1	W/m ²	Net radiation
8	1	signed integer	StDev1	W/m ²	Standard deviation of temperature compensated radiation

Table 6-1: RS-485 Register Map

Starting register number	Register count	Data format	Label	Units	Description
9	1	signed integer	BodyTemp	0.1 °C	Body temperature
10	1	signed integer	VSupply	VDC	External power voltage

7. RS-485 programming

The RS-485 output can be directly read by a MeteoPV, CR6-series, CR1000X-series, or Modbus RTU RS-485 network. Other Campbell Scientific data loggers can use an MD485 multidrop interface to read the RS-485 output (refer to the MD485 manual).

A CR6 or CR1000X data logger programmed as a Modbus Master can retrieve the values stored in the Input Registers. To do this, the CRBasic program requires a `SerialOpen()` instruction followed by the `ModbusMaster()` instruction.

The `SerialOpen` instruction has the following syntax:

```
SerialOpen (ComPort, Baud, Format, TXDelay, BufferSize, Mode)
```

The `Format` is typically set to logic 1 low; even parity, one stop bit, 8 data bits. The `Mode` parameter should configure the ComPort as RS-485 half-duplex, transparent. The `ModbusMaster()` instruction has the following syntax:

```
ModbusMaster (Result, ComPort, Baud, Addr, Function, Variable, Start, Length, Tries, Timeout, [ModbusOption])
```

The `Addr` parameter must match the sensor Modbus address. To collect all of the values, the `Start` parameter needs to be 1 and the `Length` parameter needs to correspond with the register count (see [Register map](#) (p. 5)). `ModbusOption` is an optional parameter described in the CRBasic Editor Help. Refer to [Example programs](#) (p. 7) for more information.

8. Analogue programming

The pyranometer outputs a low level voltage that is measured using either the `VoltDiff()` CRBasic instruction or `VoltSE()` CRBasic instruction.

CAUTION:

Nearby AC power lines, electric pumps, or motors can be a source of electrical noise. If the sensor or data logger is located in an electrically noisy environment, the measurement should be made with the 60 or 50 Hz rejection integration option as shown in the example programs.

If measurement time is not critical, the autorange option can be used in the `Vo1tDiff()` or `Vo1tSE()` instruction; the autorange adds a few milliseconds to the measurement time. Otherwise, select the input range as follows:

1. Estimate the maximum expected input voltage by multiplying the maximum expected irradiance (in $W \cdot m^{-2}$) by the calibration factor (in $\mu V / W \cdot m^{-2}$). Divide the answer by 1000 to give the maximum in millivolt units.
2. Select the smallest input range that is greater than the maximum expected input voltage.

If electromagnetic radiation can be a problem, use an f_{N1} of 50 or 60 Hz. The multiplier converts the millivolt reading to engineering units. [Table 8-1](#) (p. 7) provides the calculations required for the various units. The offset will normally be fixed at zero (see [Example programs](#) (p. 7)).

Units	Multiplier	Output processing
$W \cdot m^{-2}$	M	Average
$MJ \cdot m^{-2}$	$M \cdot t \cdot 0.000001$	Totalize
$kJ \cdot m^{-2}$	$M \cdot t \cdot 0.001$	Totalize
$cal \cdot cm^{-2}$	$M \cdot t \cdot 0.0239 \cdot 0.001$	Totalize
$cal \cdot cm^{-2} \cdot min^{-1}$	$M \cdot 1.434 \cdot 0.001$	Average
$W \cdot hr \cdot m^{-2}$	$M \cdot t / 3600$	Totalize

M = 1000/c, where c is the sensor output in $\mu V / W \cdot m^{-2}$
t = data logger program execution interval in seconds

9. Example programs

[Table 9-1](#) (p. 8) provides wiring for the example programs. [CRBasic Example 1](#) (p. 8) uses Modbus over RS-485 and [CRBasic Example 2](#) (p. 9).

Table 9-1: Example programs connections

Wire colour	Function	RS-485 program CR1000X connections	Analogue program CR1000X connection
Grey	RS485A	C7	N/C
Yellow	RS485B	C8	N/C
White	Power in (12 V)	12V	N/C
Black	Power ground	G	G
Green	Pyranometer signal high	N/C	1H
Brown	Pyranometer signal reference	N/C	1L
Blue	Ground	⊥ (analogue ground)	⊥ (analogue ground)

CRBasic Example 1: CR1000X program using Modbus over RS-485 to measure the SMP10

```
'CR1000X Series Datalogger
'SMP10 Pyranometer 19200 BAUD, 8 data bits, 1 stop bit, no parity
'Modbus Address Set to 51

Public PTemp : Units PTemp = DegC
Public Batt_volt : Units Batt_volt = VDC
Dim Input_Reg(10) As Long
Public SMP10_ResultCode

Alias Input_Reg(1)=Dev_Type
Alias Input_Reg(2)=Version
Alias Input_Reg(3)=Mode
Alias Input_Reg(4)=Dev_Flags
Alias Input_Reg(5)=R_S_Factor
Alias Input_Reg(6)=TC_SRad
Alias Input_Reg(7)=Raw_SRad
Alias Input_Reg(8)=Stan_Dev
Alias Input_Reg(9)=Body_Temp
Alias Input_Reg(10)=Ext_Pwr

Public SMP10_NetRadiation : Units SMP10_NetRadiation = W/m^2
Public SMP10_NetRadTempCor : Units SMP10_NetRadTempCor = W/m^2
Public SMP10_BodyTemp : Units SMP10_BodyTemp = DegC

DataTable (Hourly,1,-1)
  DataInterval (0,60,Min,10)
  Minimum (1,Batt_volt,FP2,False,False)
  Sample (1,PTemp,FP2)
```

CRBasic Example 1: CR1000X program using Modbus over RS-485 to measure the SMP10

```
Average (1,SMP10_NetRadTempCor,IEEE4,False)
StdDev (1,SMP10_NetRadTempCor,IEEE4,False)
Average (1,SMP10_BodyTemp,IEEE4,False)
StdDev (1,SMP10_BodyTemp,IEEE4,False)
Maximum (1,SMP10_ResultCode,FP2,False,False)
EndTable

BeginProg
SerialOpen (ComC7,19200,18,0,300,4)

Scan (5,Sec,0,0)
  PanelTemp (PTemp,60)
  Battery (Batt_volt)

  'Modbus RS485
  ModbusMaster(SMP10_ResultCode,ComC7,19200,51,3,Input_Reg(),1,10,1,100,3)
  If SMP10_ResultCode = 0 Then
    SMP10_NetRadiation=Raw_SRad
    SMP10_NetRadTempCor=TC_SRad
    SMP10_BodyTemp=Body_Temp*0.1
  Else
    SMP10_NetRadiation=NAN
    SMP10_NetRadTempCor=NAN
    SMP10_BodyTemp=NAN
  EndIf

  CallTable Hourly
NextScan
EndProg
```

CRBasic Example 2: CR1000X program using analogue voltage to measure the SMP10

```
'CR1000X Series Datalogger

Public PTemp : Units PTemp = DegC
Public Batt_volt : Units Batt_volt = VDC
Public SMP10_NetRadAnalog : Units SMP10_NetRadAnalog = W/m^2

DataTable (Hourly,1,-1)
  DataInterval (0,60,Min,10)
  Minimum (1,Batt_volt,FP2,False,False)
  Sample (1,PTemp,FP2)
  Average (1,SMP10_NetRadAnalog,IEEE4,False)
  StdDev (1,SMP10_NetRadAnalog,IEEE4,False)
EndTable
```

```
BeginProg
Scan (5,Sec,0,0)
  PanelTemp (PTemp,60)
  Battery (Batt_volt)
  VoltDiff(SMP10_NetRadAnalog,1,mV1000,1,True,0,60,2.2,-200)

  CallTable Hourly

NextScan
EndProg
```

10. Maintenance and troubleshooting

The SMP10 has no service items requiring scheduled replacement. There is no accessible desiccant cartridge to maintain. Use pure alcohol or distilled water and a lint-free cloth to clean the dome, removing smears and deposits. Local conditions and application dictate cleaning interval. Sophisticated research applications require daily cleaning. For typical PV applications, clean once per week, bi-monthly, or monthly. The SMP10 should be recalibrated following industry standard best practices such as ASTM G167, ISO 9846, ASTM E824 or ASTM G207 by an accredited lab. The recommended recalibration interval is two years. Contact Campbell Scientific for more information.

Unexpected results typically occur because of improper wiring or programming, electromagnetic radiation, or damaged cables. Ensure that the data logger program includes the correct parameters for the measurement instructions. Check for the presence of strong sources of electromagnetic radiation and use the 50 or 60 Hz integration option in the data logger program if electromagnetic radiation can be a problem. Check the cable for damage and ensure that it is properly connected to the data logger.



Global Sales & Support Network

A worldwide network of companies to help meet your needs



- Campbell Scientific group companies
- Sales representatives

Australia

Location: Garbutt, QLD Australia
Phone: 61.7.4401.7700
Email: info@campbellsci.com.au
Website: www.campbellsci.com.au

Brazil

Location: São Paulo, SP Brazil
Phone: 11.3732.3399
Email: vendas@campbellsci.com.br
Website: www.campbellsci.com.br

Canada

Location: Edmonton, AB Canada
Phone: 780.454.2505
Email: dataloggers@campbellsci.ca
Website: www.campbellsci.ca

China

Location: Beijing, P. R. China
Phone: 86.10.6561.0080
Email: info@campbellsci.com.cn
Website: www.campbellsci.com

Costa Rica

Location: San Pedro, Costa Rica
Phone: 506.2280.1564
Email: info@campbellsci.cc
Website: www.campbellsci.cc

France

Location: Vincennes, France
Phone: 0033.0.1.56.45.15.20
Email: info@campbellsci.fr
Website: www.campbellsci.fr

Germany

Location: Bremen, Germany
Phone: 49.0.421.460974.0
Email: info@campbellsci.de
Website: www.campbellsci.de

South Africa

Location: Stellenbosch, South Africa
Phone: 27.21.8809960
Email: sales@campbellsci.co.za
Website: www.campbellsci.co.za

Southeast Asia

Location: Bangkok, Thailand
Phone: 66.2.719.3399
Email: thitipongc@campbellsci.asia
Website: www.campbellsci.asia

Spain

Location: Barcelona, Spain
Phone: 34.93.2323938
Email: info@campbellsci.es
Website: www.campbellsci.es

UK

Location: Shepshed, Loughborough, UK
Phone: 44.0.1509.601141
Email: sales@campbellsci.co.uk
Website: www.campbellsci.co.uk

USA

Location: Logan, UT USA
Phone: 435.227.9120
Email: info@campbellsci.com
Website: www.campbellsci.com