



Sprint Top

Installation Instructions

For: Jeep Wrangler JK 4 Door
2007 – 2009

Part Number: 56845



Installation Tips

For a smooth fit:

For easier installation, the top should be installed at a temperature above 72° F. Below this temperature, the fabric may contract an inch or more, making it difficult to fit the vehicle.

It is normal for the fabric to contract and wrinkle when stored in the shipping carton. Within a few days after installation, the fabric will relax and the wrinkles will disappear.



WARNING

This product is designed to enhance the appearance of the vehicle. Do not rely in any way on the components of this product to contain occupants within the vehicle, or to protect against injury or death in the event of an accident. Never operate vehicle in excess of manufacturer's specifications.

WEAR SEAT BELTS AT ALL TIMES

Read and follow, precisely, all installation instructions provided when installing this product. Failure to do so could place occupants of the vehicle in a potentially dangerous situation. After installing or reinstalling, check to make sure it has been properly installed.



CAUTION

Safety glasses should be worn at all times while installing this product.



!STOP! Do not proceed unless you have a Factory Original Soft Top already installed.
You will need these parts to complete the Sprint Top installation
These Parts Are Not Included

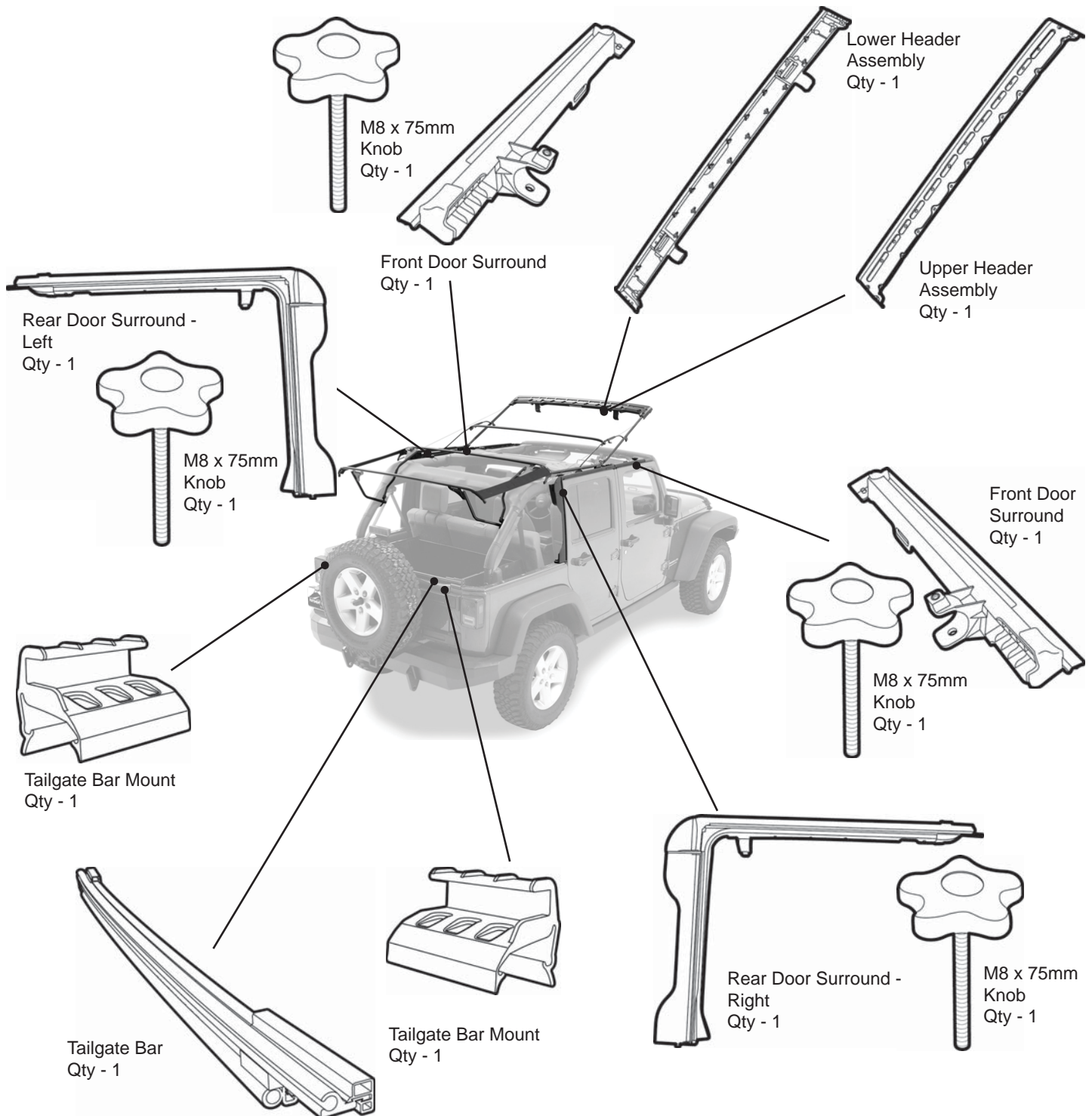

If you do not have these parts, they are available for purchase separately from an authorized Mopar dealer.

Parts List - These Parts Are Included

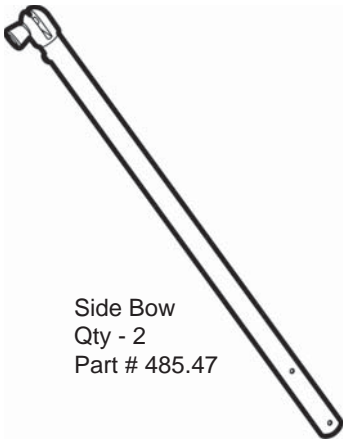

Side Bow
Qty - 2
Part # 485.47



Foam Tape Strips
Qty - 2
Part # 417.43

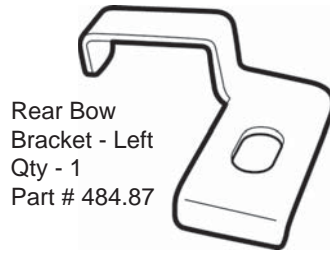

Rear Bow
Bracket - Left
Qty - 1
Part # 484.87

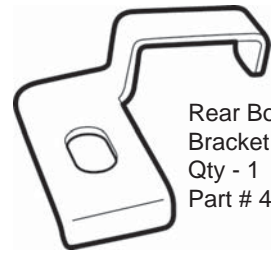

Rear Bow
Bracket - Right
Qty - 1
Part # 484.86

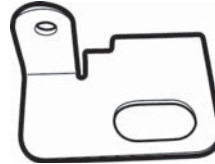

Pivot Bracket
Qty - 1
Part # 485.51 - Left

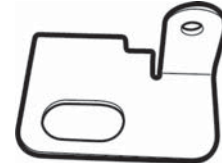

Pivot Bracket
Qty - 1
Part # 485.50 - Right



Middle Bow
Qty - 1
Part # 486.21

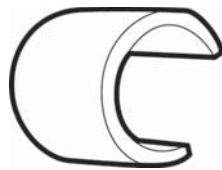

Bow Clip
Qty - 1,
Part # 479.22

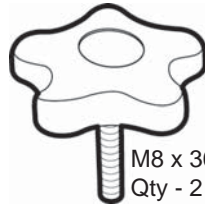

M8 x 30mm Knob
Qty - 2
Part # 480.22

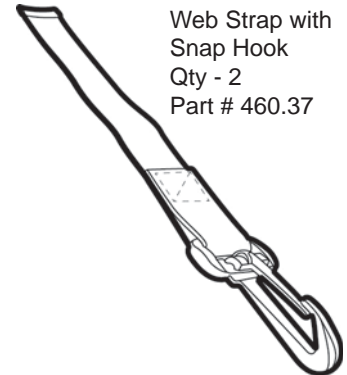

Web Strap with
Snap Hook
Qty - 2
Part # 460.37



Rear Bow
Qty - 1
Part # 486.18

Deck, Header Assembly, & Fabric Top

Right Side Window

Left Side Window

Rear Window



Section 1

Remove Side and Rear Windows

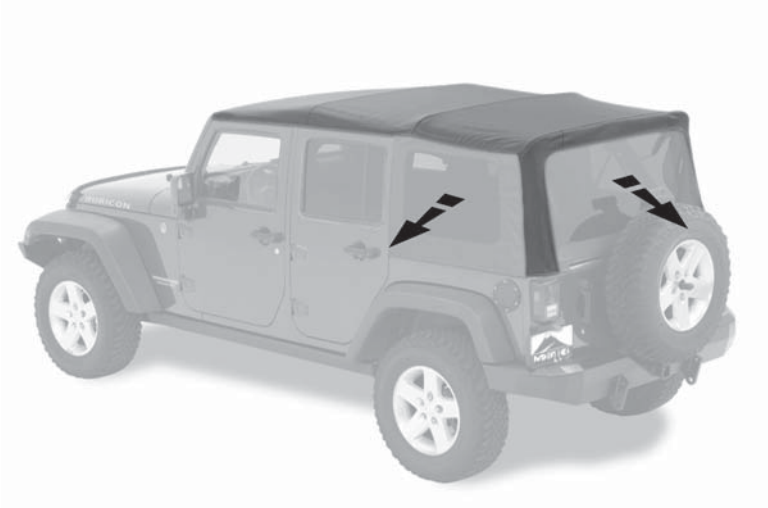

Step One

Remove Side Windows and Rear Window.



Section 2 Remove Fabric and Side Bows from Header

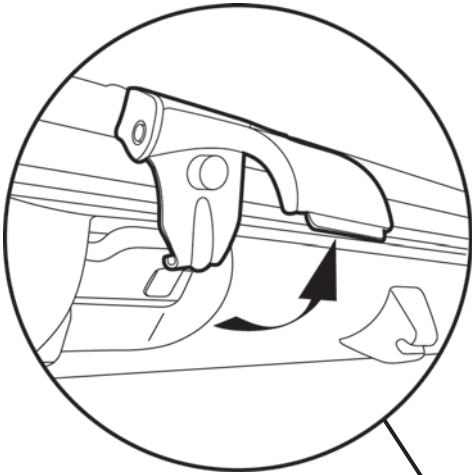

Step One

Release the latch that secures the header to the windshield. Pull up on the lever and then down and out to release the hook from the loop in the windshield frame

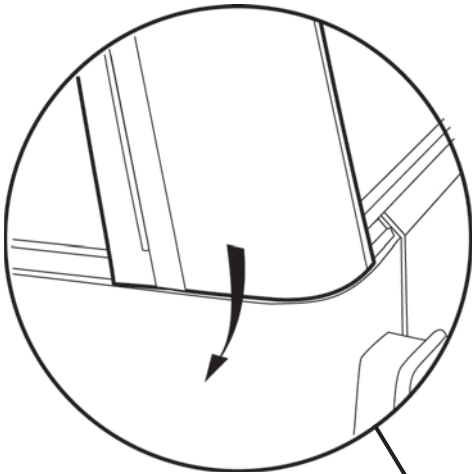

Step Two

Release the rear corners of the top. Pull gently down and then out to release the plastic strip from the retainer on the vehicle.

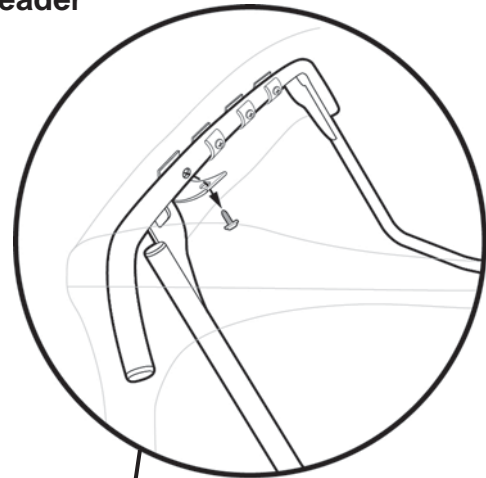

Step Three

Use a phillips screwdriver to remove the four (4) screws that attach the flaps in the top to the Rear Bow. Allow the bow to drop onto the tailgate **Set the screws aside to be reused later.**

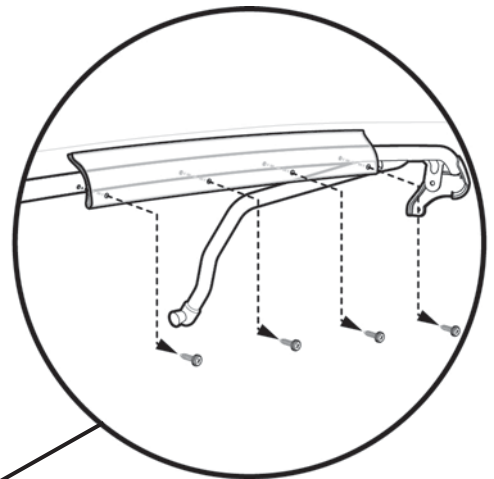

Step Four

Use a phillips screwdriver to remove the four (4) screws that attach the fabric to the #3 Bow. **Set the screws aside to be reused later.**

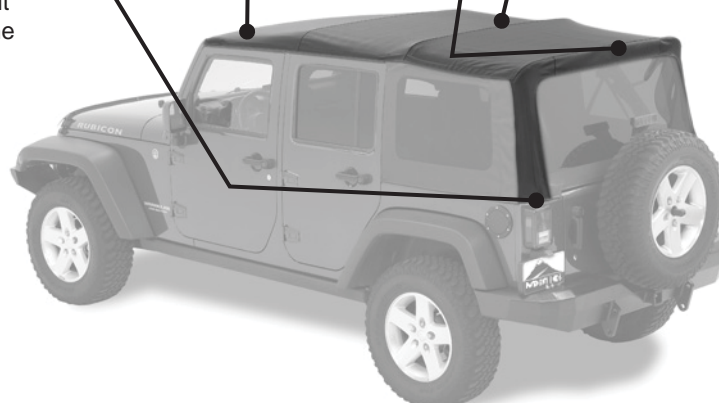

Section 2 Remove Fabric and Side Bows from Header (cont.)

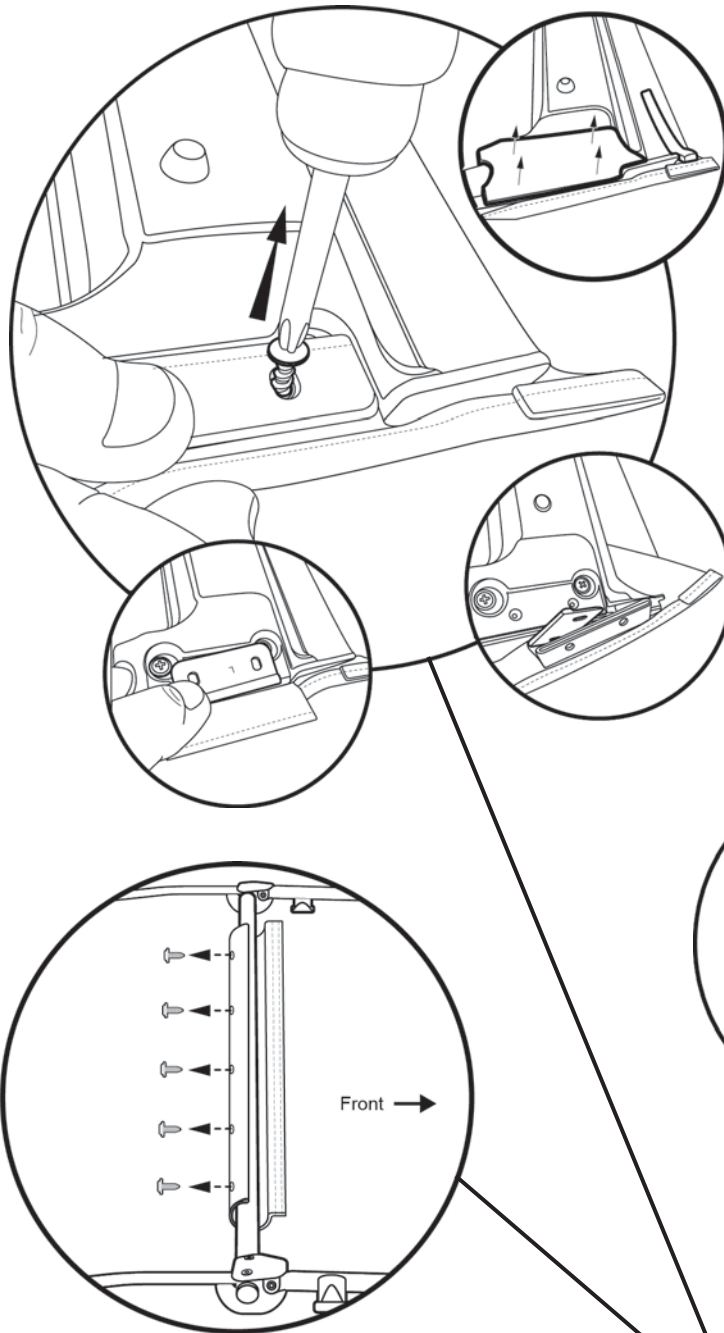

Step Six

Fold the bow assembly down onto the tailgate to access the header. Remove the Foam Seals. Use a phillips screwdriver to remove the two screws that secure the fabric to the header.

Set the screws aside to be reused later.

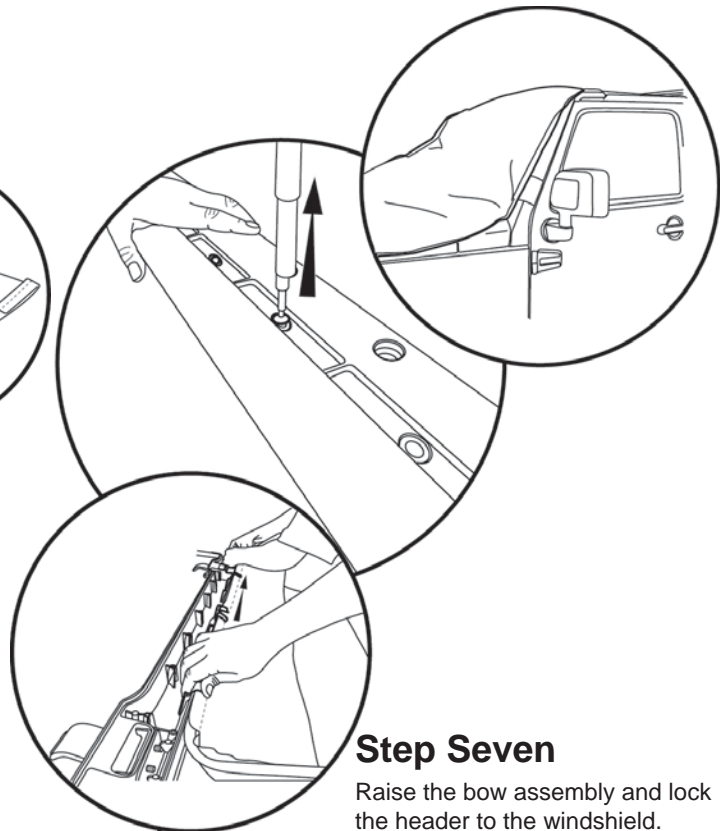

Step Seven

Raise the bow assembly and lock the header to the windshield.

Drape the top fabric, backing side up, over the hood and windshield. Remove all screws that secure the fabric to the upper and lower headers. **Set the screws aside for use in installing the new top.**

Remove the fabric along the front edge of the top out of the channel in the lower header and remove the old top from the vehicle.

Step Five

Use a phillips screwdriver to remove (5) #8x1/2" Pan Head Washer Screws that secure the fabric flap to the #2 Bow.

Set the screws aside to be reused later.



Section 3

Remove and Store All Bows

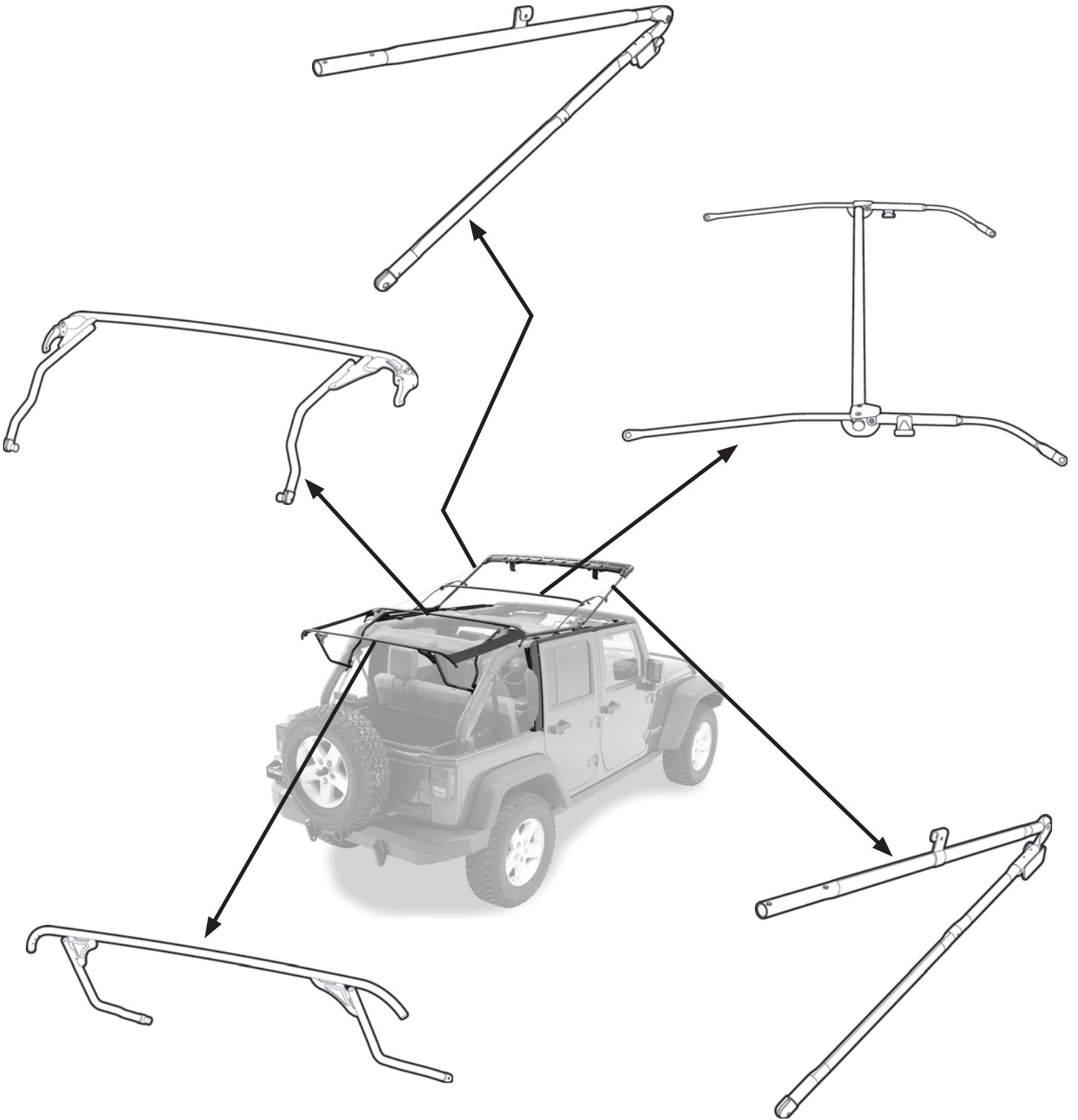

Step One

Remove and store all bows.

Section 4 Install Sprint Top Fabric on Header

Step Two

Install the extrusion along the front of the fabric into the header channel.

Center the fabric and use masking tape to hold it in position.

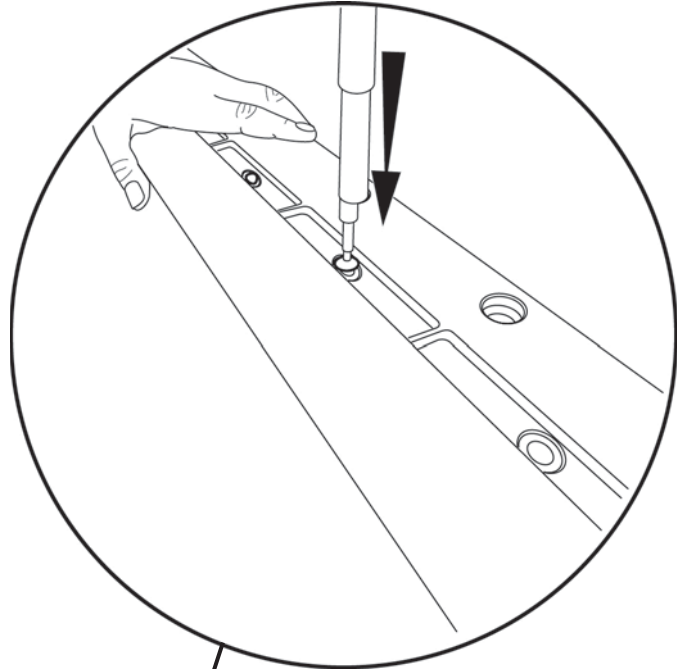
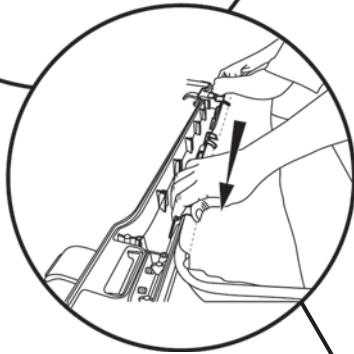
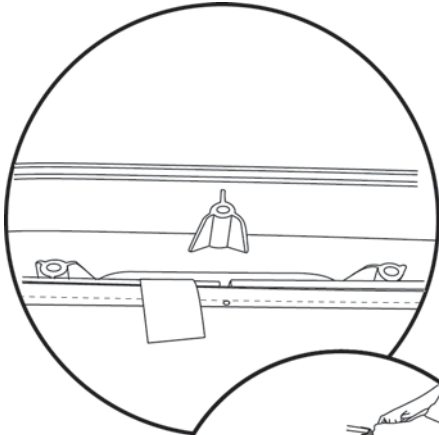

Step One

Lay the Lower Header on the ground and position the Sprint Top fabric in the same position as the original top that was removed.

Step Three

Place the Upper Header onto the Lower Header assembly and reinstall the screws removed in section 2.



Section 5

Attach Side Bows to Header/Fabric Assembly

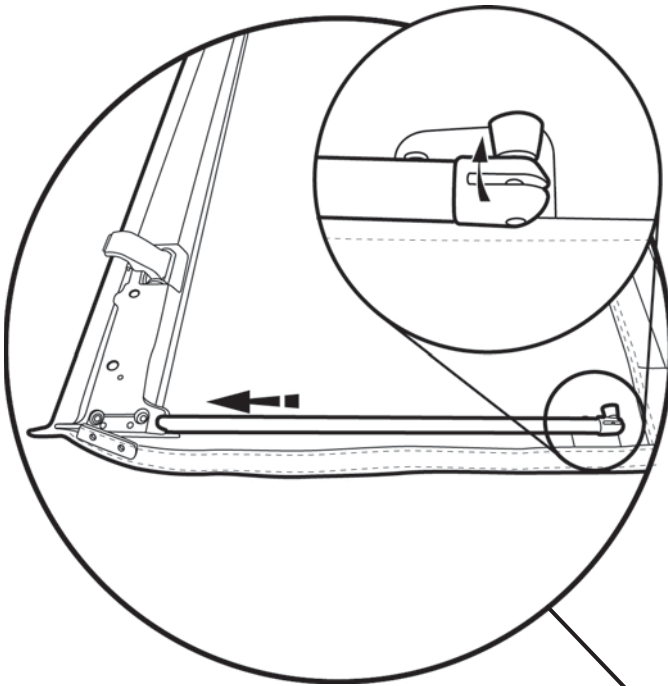

Step One

Insert Side Bows into Header Assembly on each side.

Pivot quick release knobs to face toward inside of assembly.

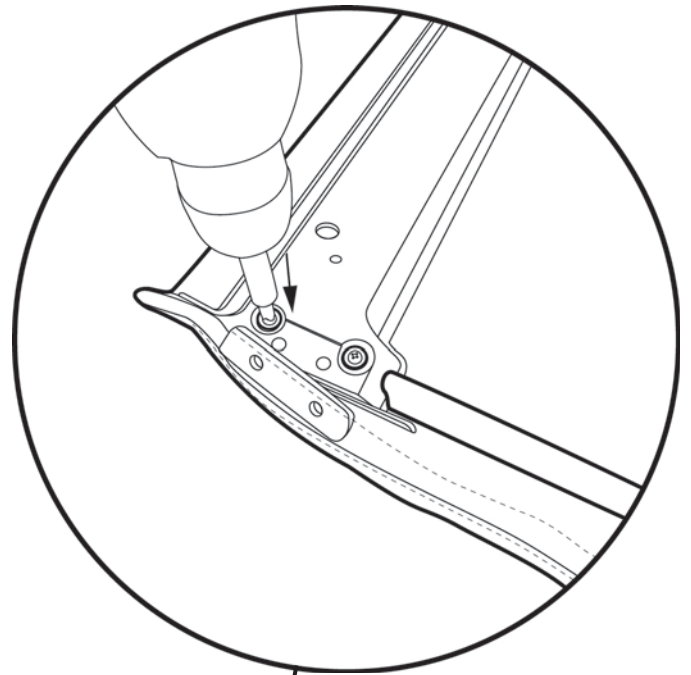

Step Two

Re-use the original #8 x 1/2" Screws to mount a Side Bow to each side of the Header Assembly.



Section 5

Attach Side Bows to Header/Fabric Assembly (cont.)

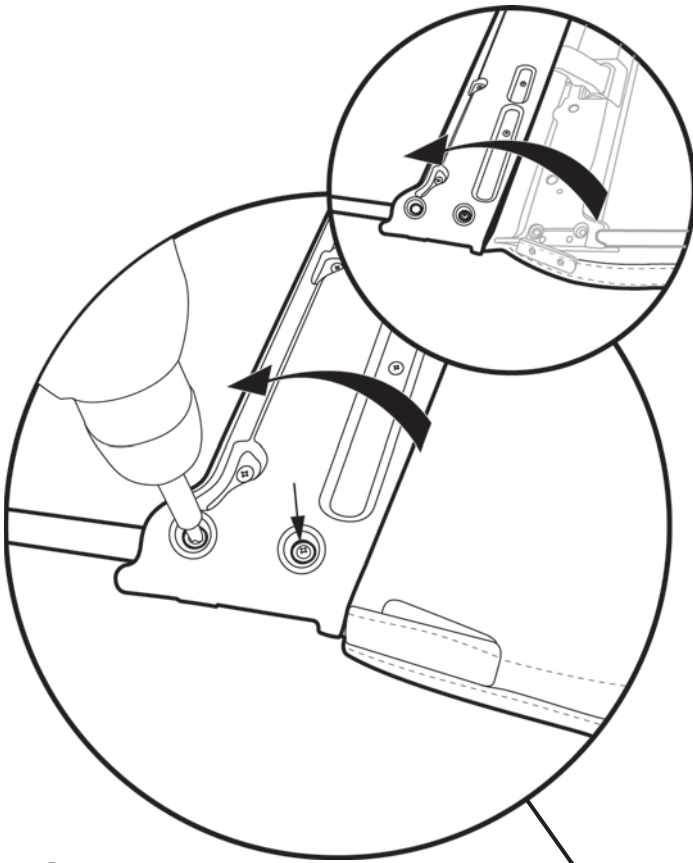

Step Three

Rotate the Header Assembly and re-use the original #8 x 1/2" Screws removed in section 2 to complete the side bow install.

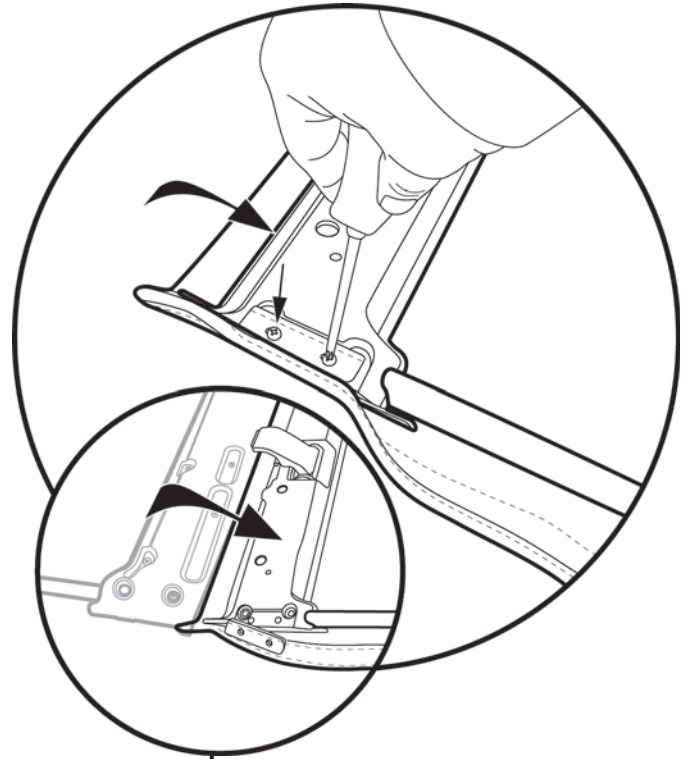

Step Four

Rotate the Header Assembly back into position and re-use the screws removed removed in section 2.



Section 6 Install Foam Tape Strips and Foam Seals

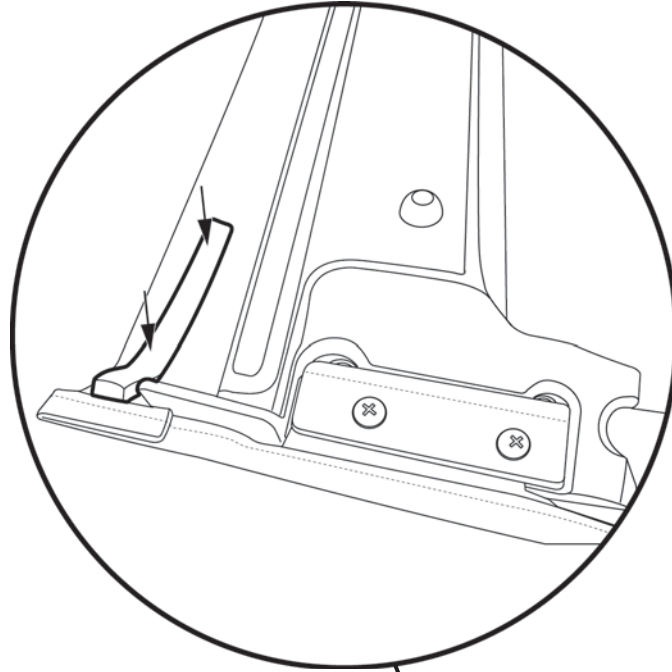

Step One

Peel the backing off the Foam Tape Strips and install them on each side of the Header.



Section 7

Install Rear Bow Brackets

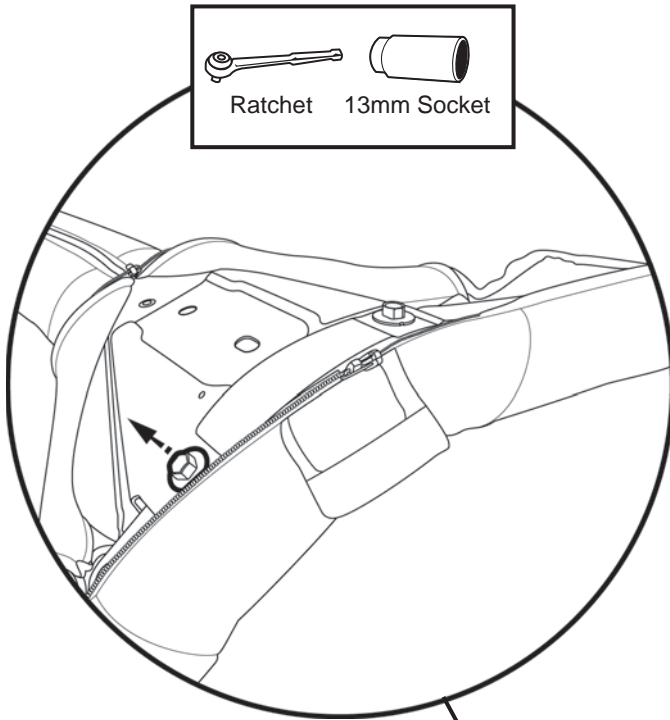

Step One

Locate the rear sport bar bolt. Use a 13mm socket and ratchet to remove the bolt and set it aside to be reused.

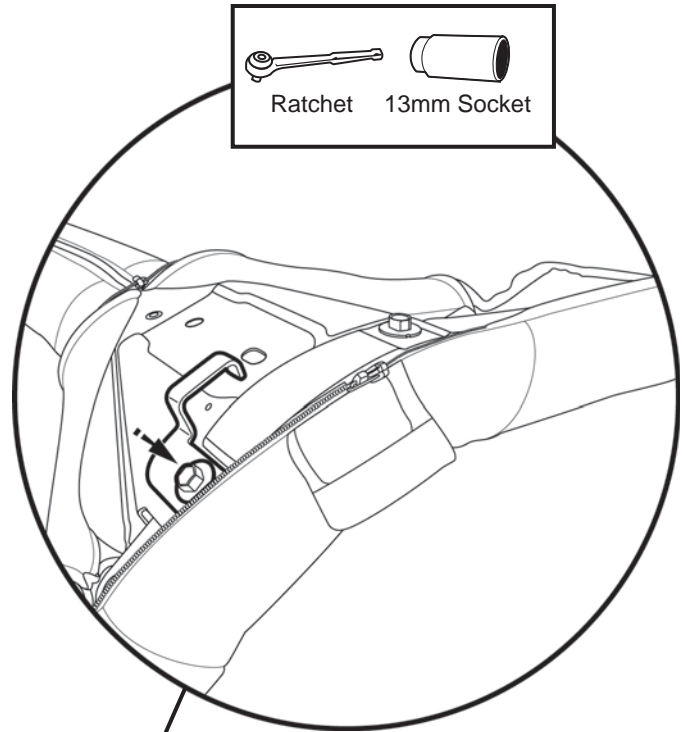

Step Two

Loosely install the Rear Bow Bracket with the sport bar bolt. Mark where the bracket contacts the sport bar cover and remove the bracket.



Section 7

Install Rear Bow Brackets (cont.)

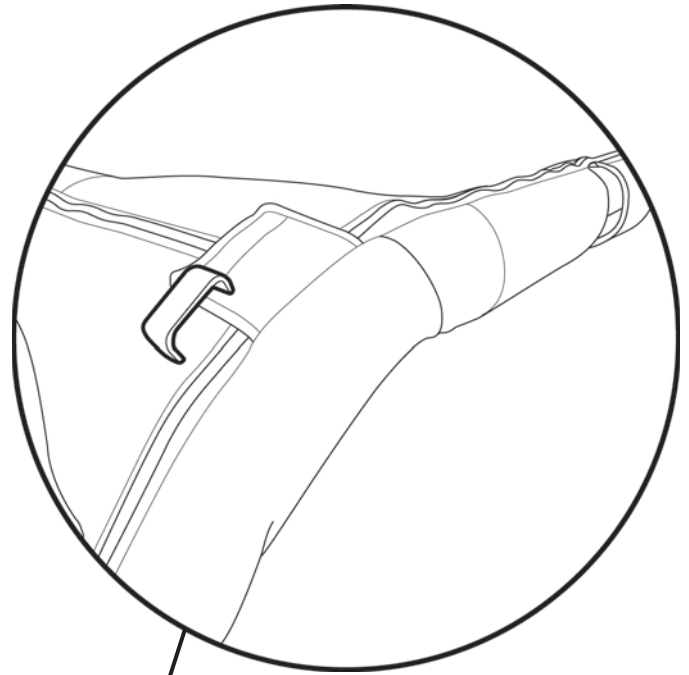
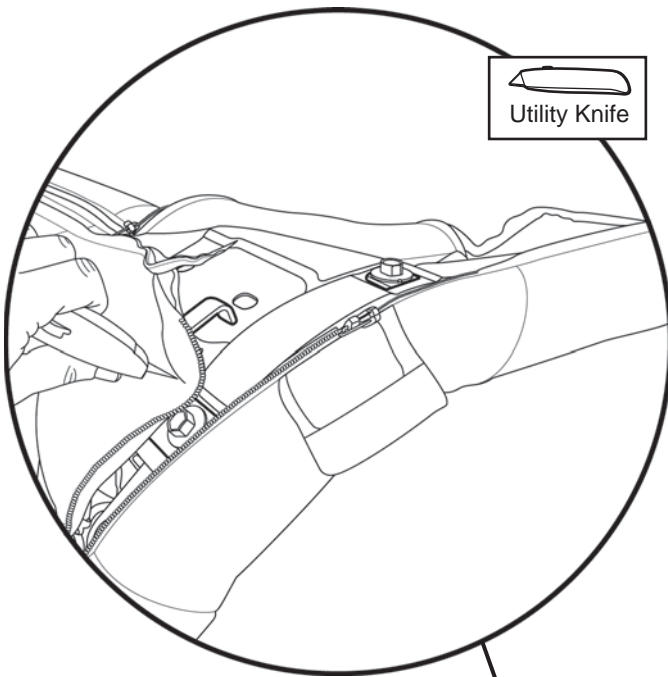

Step Three

Cut a horizontal slit the same width as the Rear Bow Bracket at this point.

Reinstall the Rear Bow Bracket through the cover and tighten the bolt.

Step Four

Zip all sport bar covers.

Repeat on both sides of the vehicle.



Section 8

Install Rear Door Surrounds

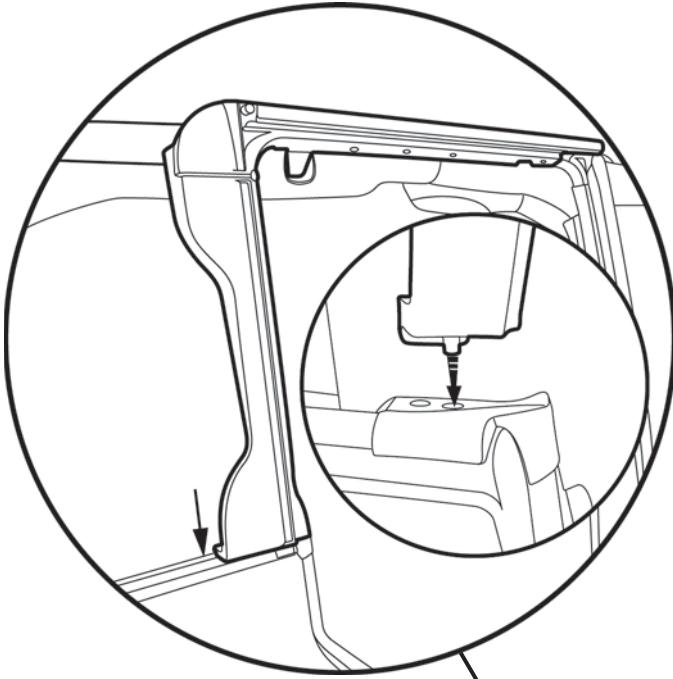

Step One

Insert the pin in the bottom of the Rear Door Surround into the hole in the belt rail behind the rear door opening. Press the channel along the top of the Rear Door Surround around the horizontal sport bar.

Repeat on the other side of the vehicle.

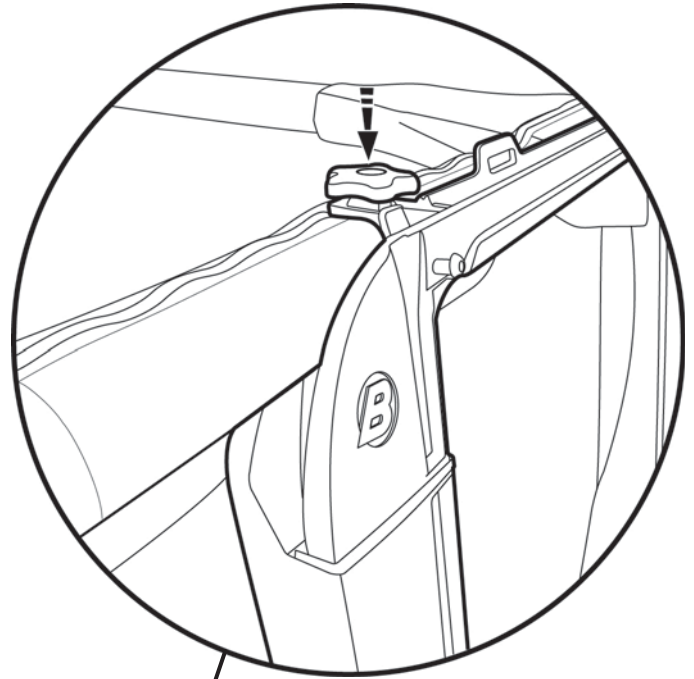

Step Two

Insert the long knob removed in section 3 into the rear position on the Door Surround.

Repeat on the other side of the vehicle.



Section 9

Install Front Door Surrounds

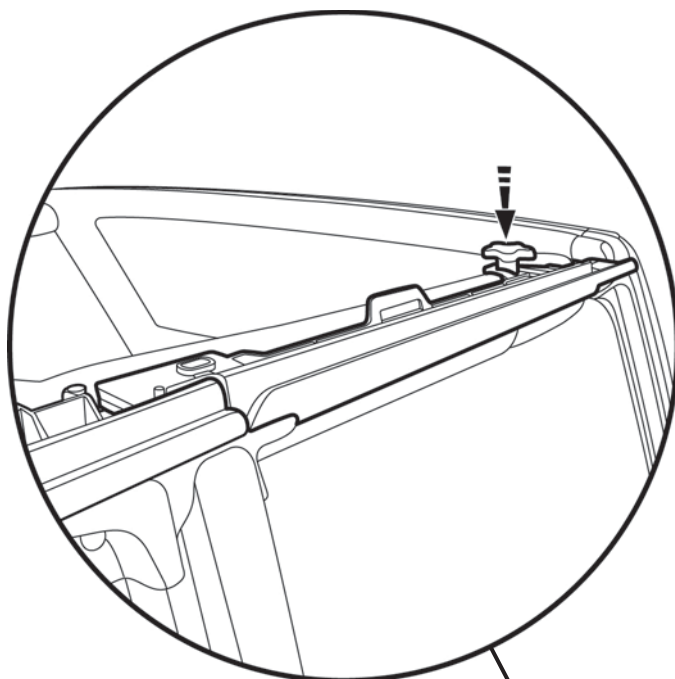

Step One

Position the Front Door Surround on the sport bar above the driver's door and press it into place as with the rear.

Step Two

Insert the long knob removed in section 3 into the rear position on the Door Surround. Repeat on the other side of the vehicle.



Section 10 Install Pivot Bracket

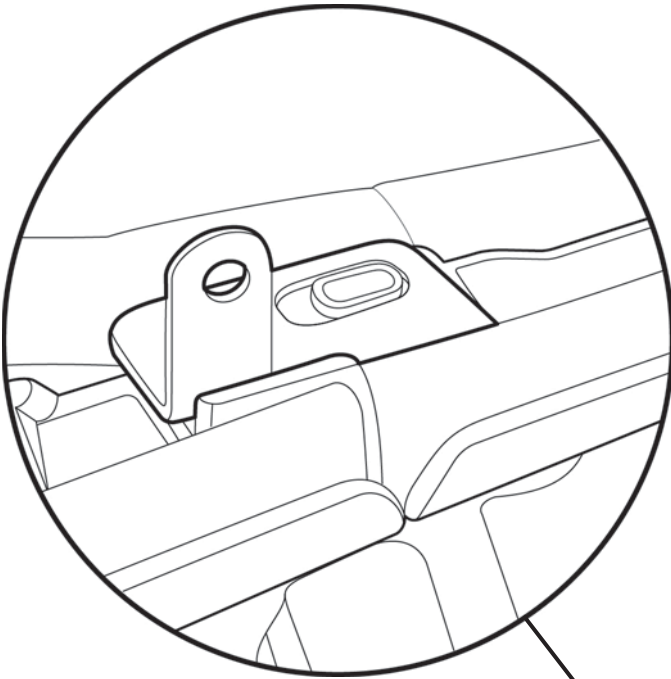

Step One

Place the Left Pivot Bracket over the hole where the Front and Rear Door Surrounds join.

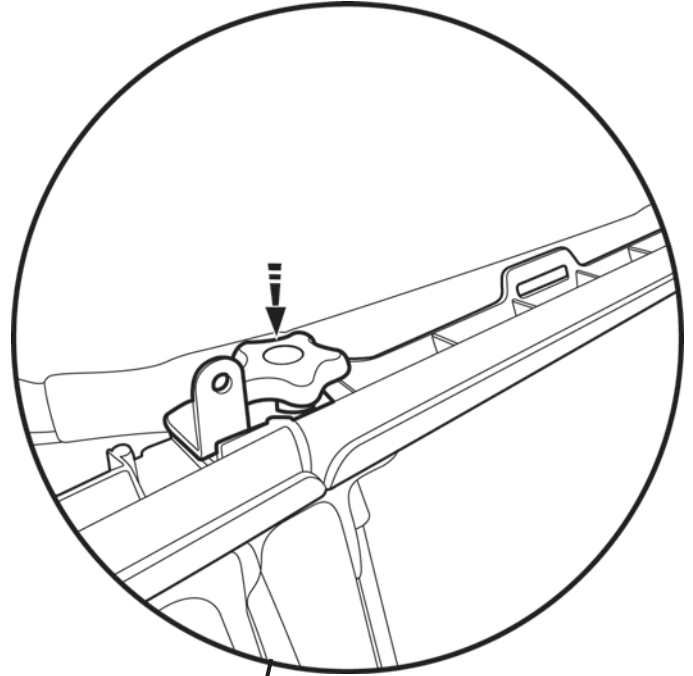

Step Two

Secure it with the M8 x 30mm Knob. Repeat on both sides.



Section 11 Install Tailgate Bar Mounts

Step One

Orient the Tailgate Bar Mounts on the vehicle. Hook the bottom of one mount under the ledge and roll the mount toward the outside of the vehicle until it clips into place under the belt rail. Repeat this with both Tailgate Bar Mounts.

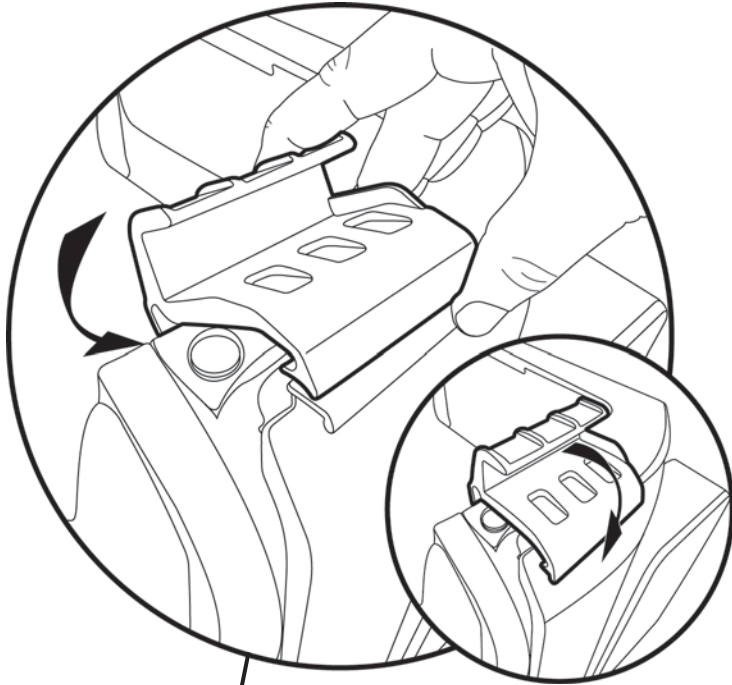

Section 12 Mount Header Assembly to Sunrider Bracket

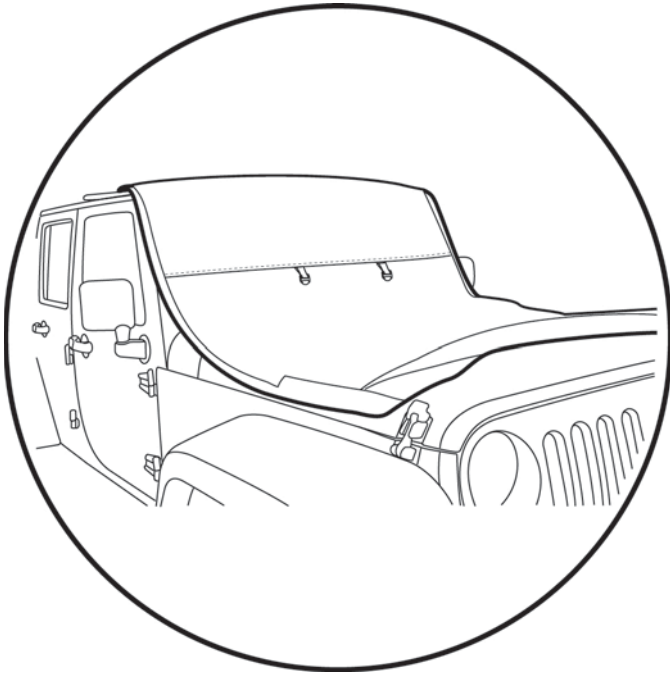

Step One

Fold the Top Fabric toward the front of the Header. Place the Header Assembly on vehicle, with the backing up and the Side Bows on top of the Door Surrounds.

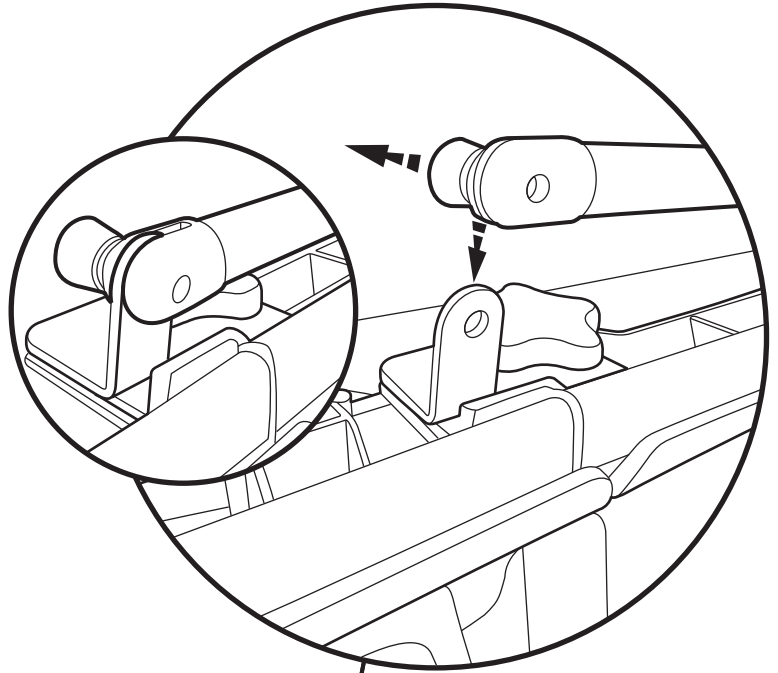

Step Two

Pull back on the quick release knob on the Side Bow and slide the Side Bow over the Sunrider Bracket. The spring pin should install all the way into the pivot when complete. Repeat on the other side of the vehicle.



Section 13 Install Middle Bow and Bow Clip

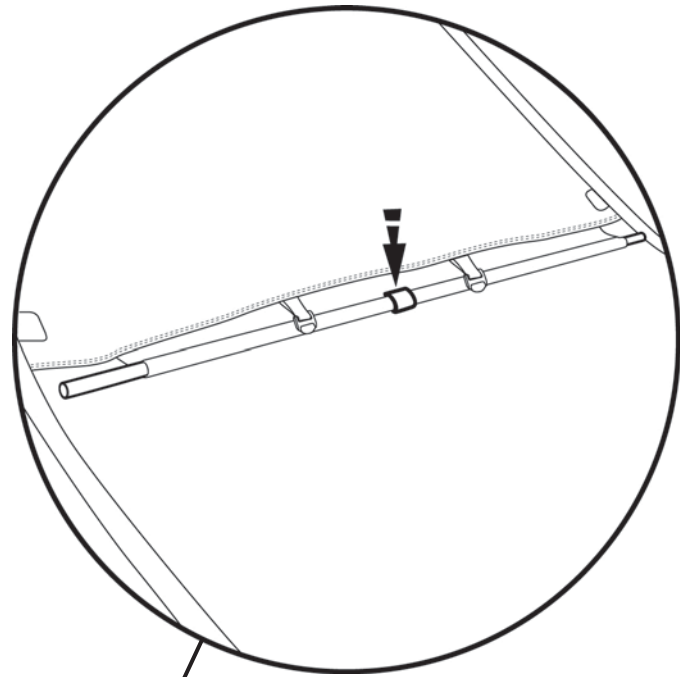
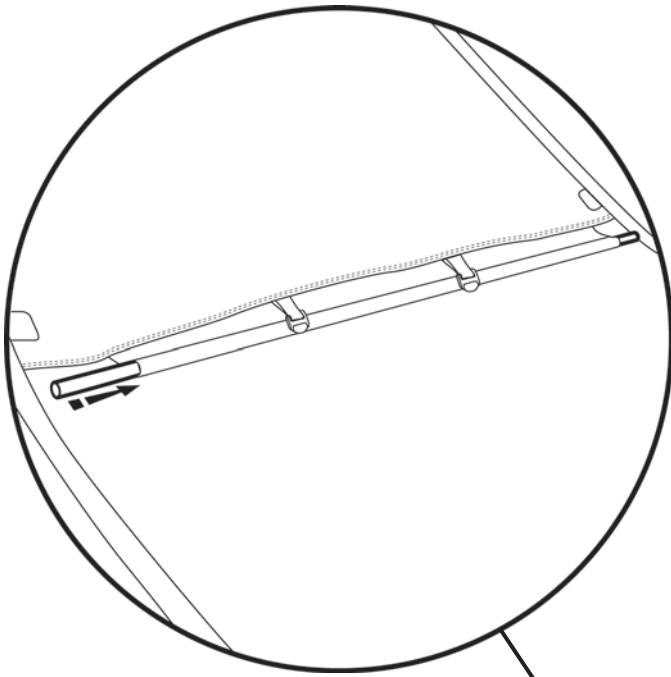

Step One

Slide the Middle Bow into the sleeve inside the Top.

Step Two

Hook the Bow Clip to the Middle Bow to secure the fabric sleeve.



Section 14

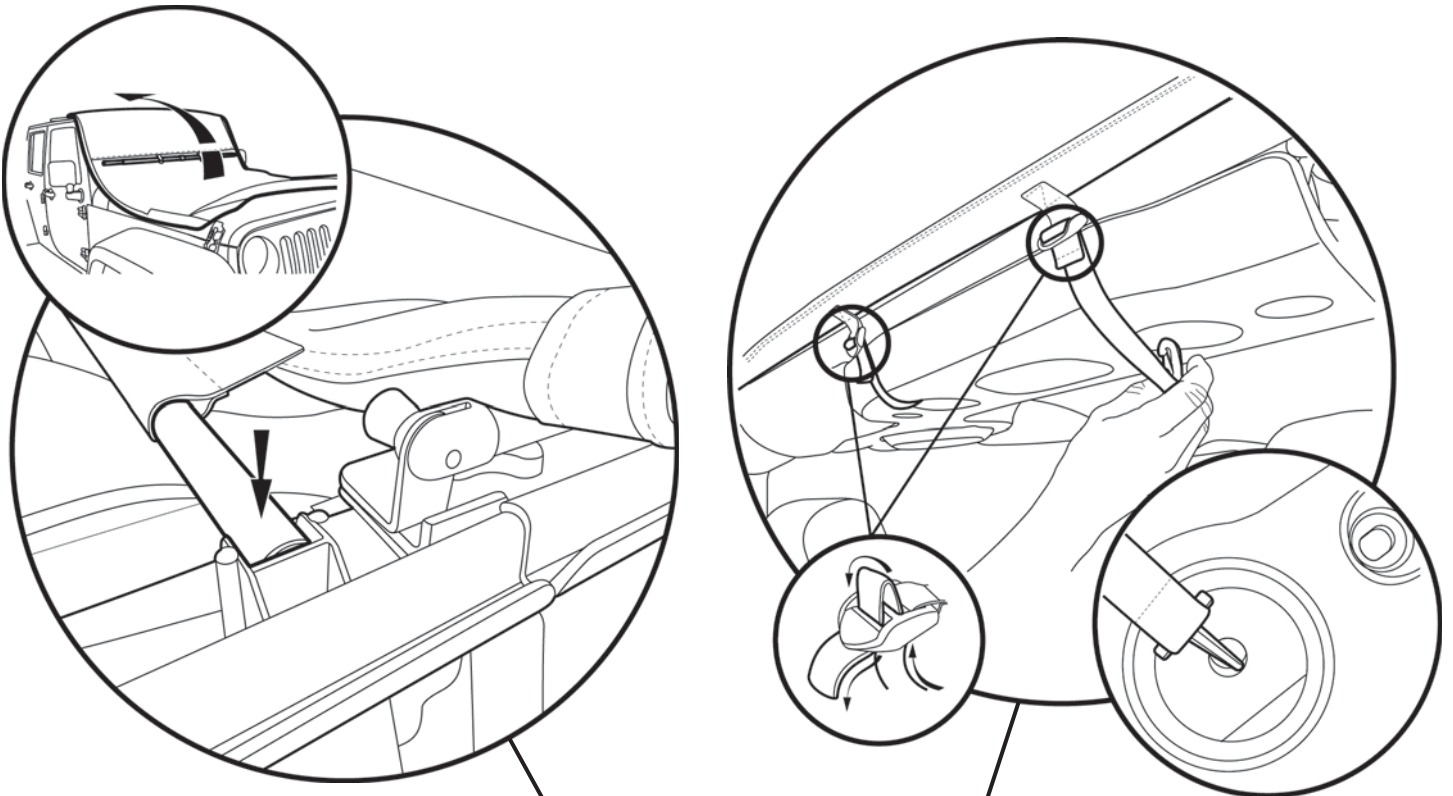

Step One

Drape the Top Fabric over the Top Arches and the sport bars.

Make sure the Middle Bow is centered in the vehicle and sits in the slot in the Door Surround on each side.

Middle Bow fits snug to soundbar.

Step Two

Thread a Web Strap with Snap Hook through each buckle. Hook the straps into the slot on the underside of the sportbar. Pull the ends of each strap to tighten securely.

Make sure Middle Bow is secure in slot before pulling Center Straps tight.

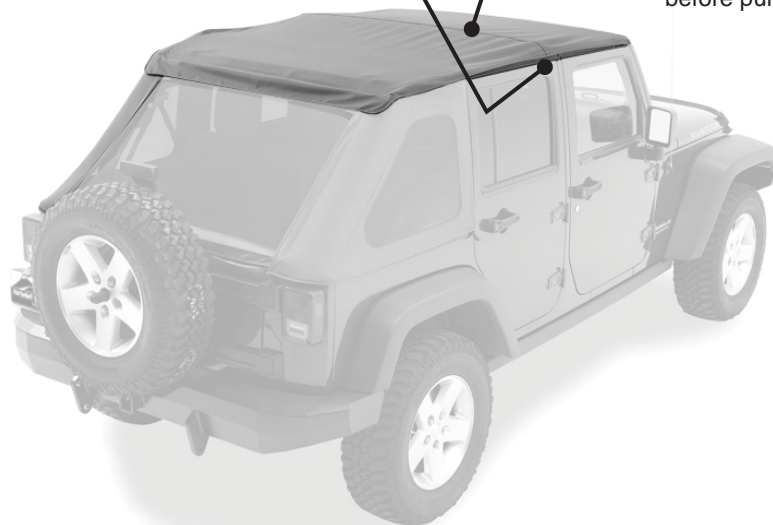

Section 15 Open Header and Install Rear Bow

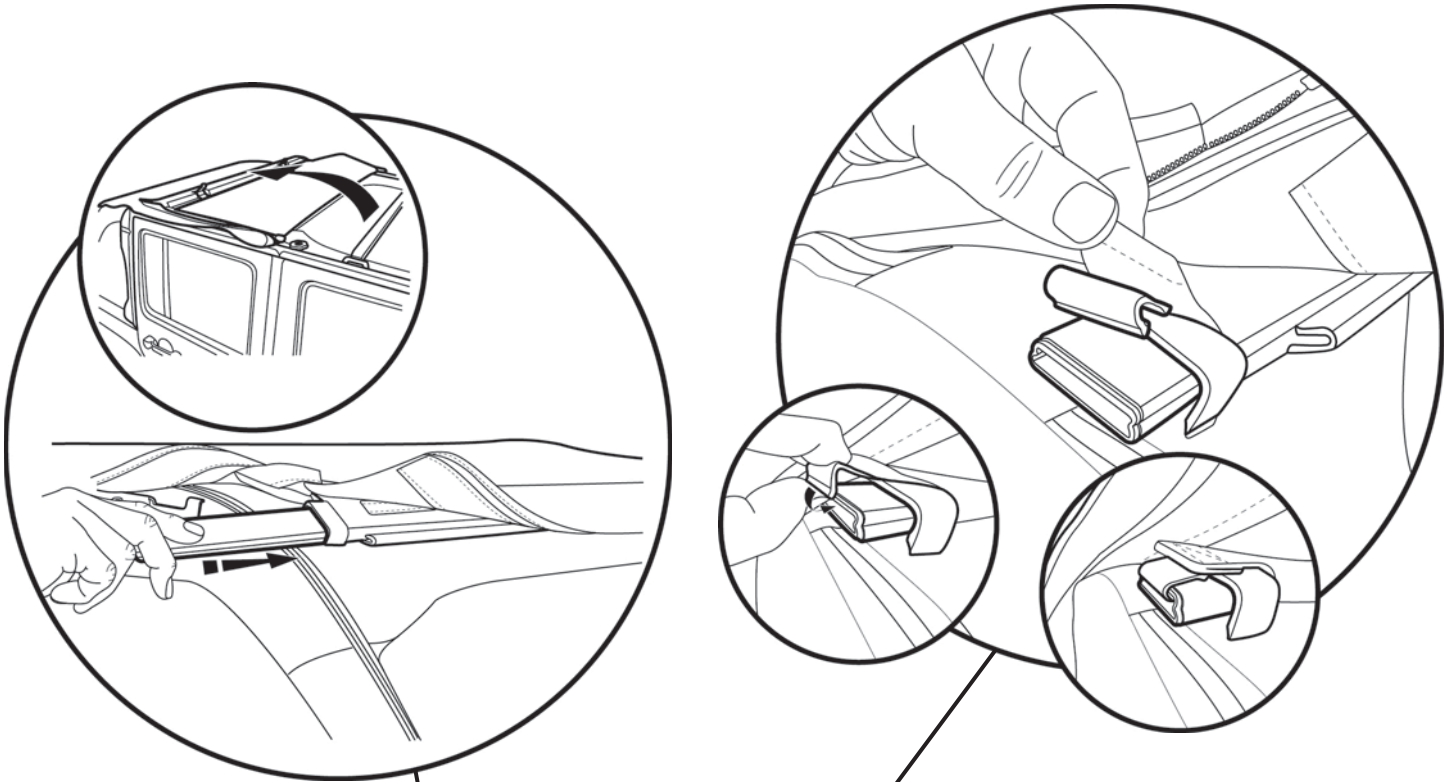

Step One

Open Header.

Slide the Rear Bow into the pocket inside the rear of the Top Fabric.

Slide the bow into the Rear Bow Brackets. Make sure it is centered between the brackets.

Step Two

Secure the J-Hooks on the rear bow flaps to the ends of the Rear Bow.

Repeat on opposite side.

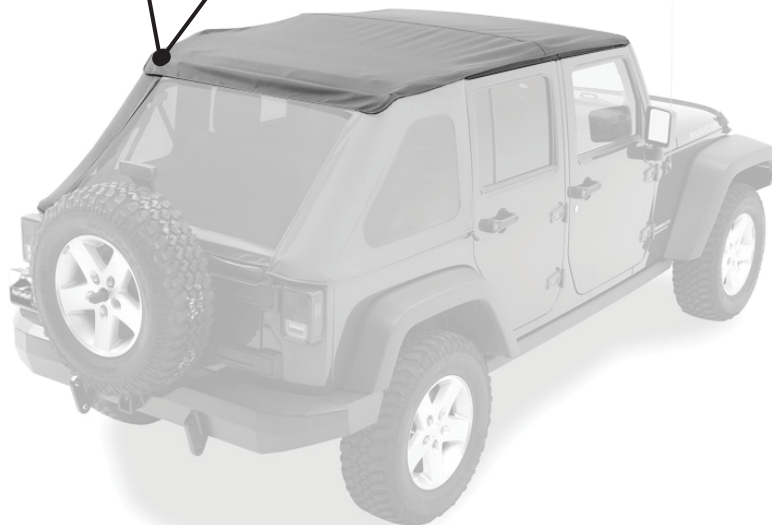

Section 16 Close Header and Secure Header Latch

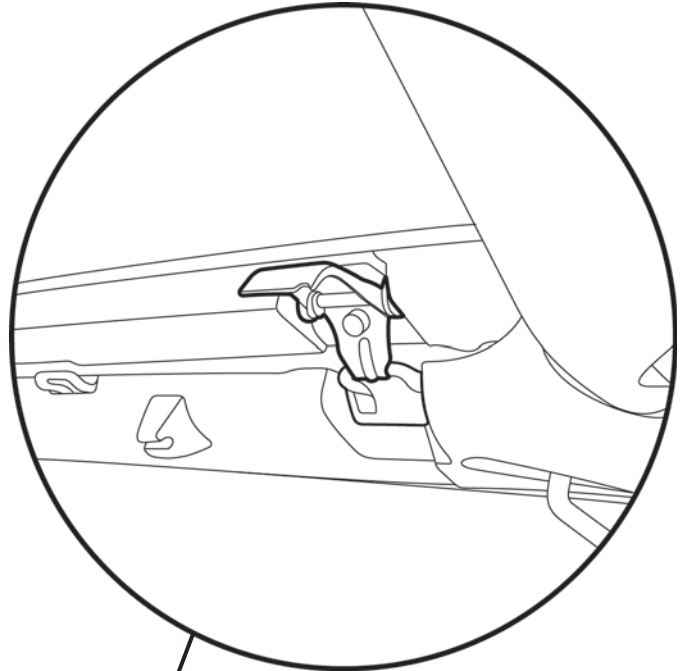
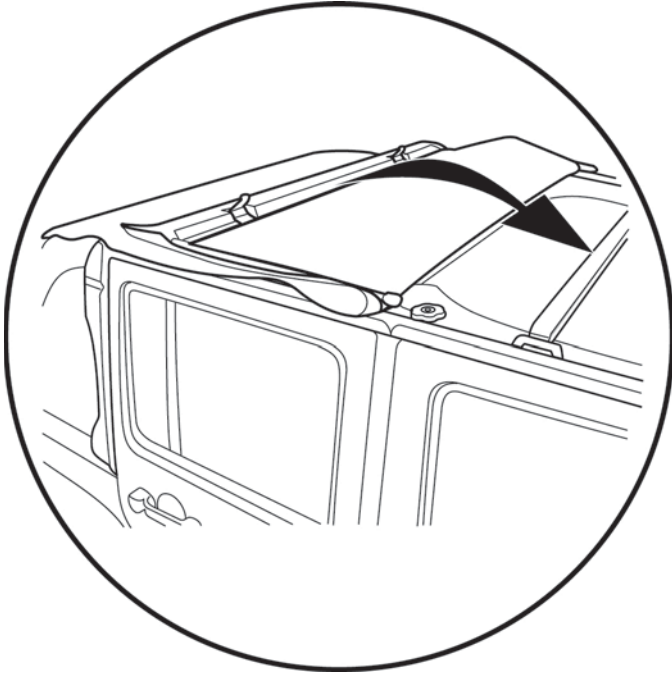

Step One

Close Header.

Step Two

Hook the latches on the Header into the loops in the windshield.

Repeat on opposite side..



Section 17 Install Rear Window

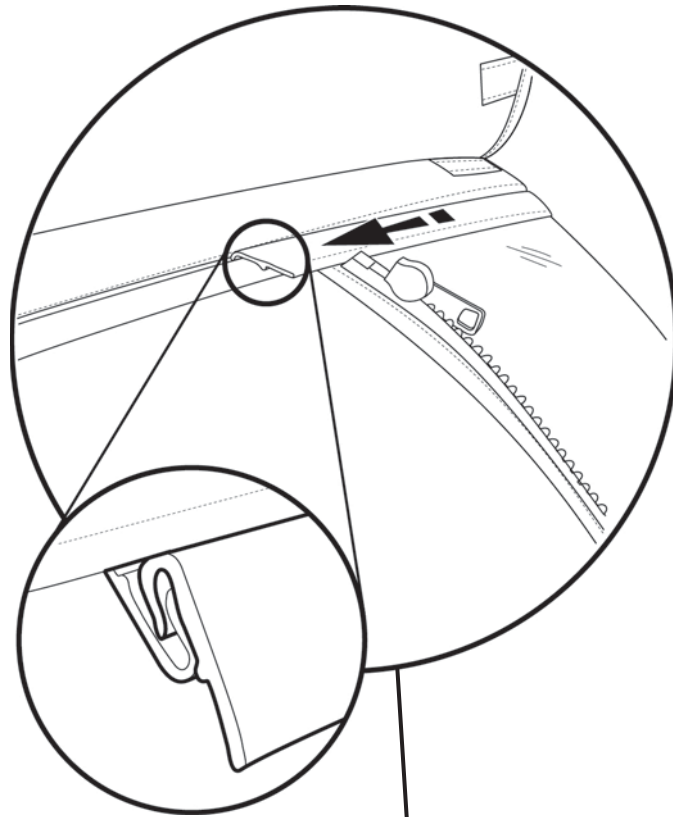

Step One

Align the J-slide with the J-slide sewn into the rear of the Top. Slide them together until the Rear Window is centered in the opening.



Section 18 Install Side Window

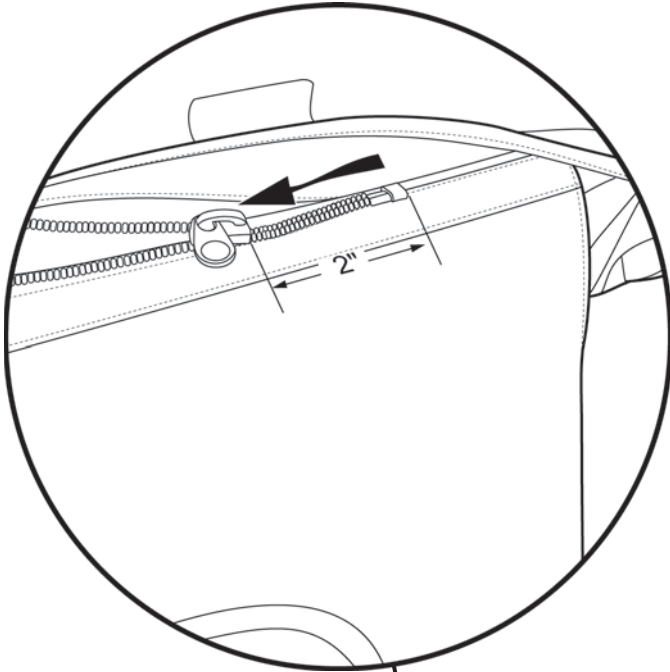

Step One

Start the zipper along the top of the Side Window with the zipper in the Top. Only close the zipper 1-2".

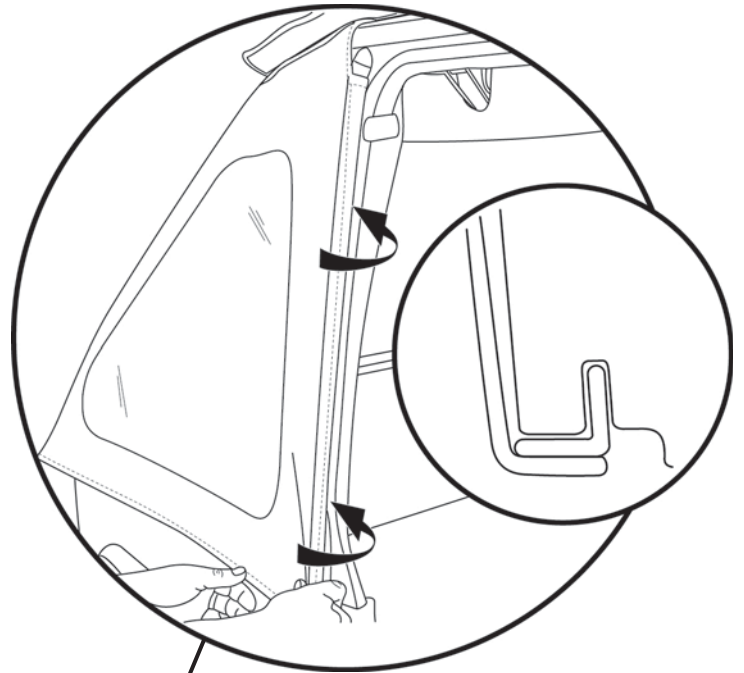

Step Two

Slip the plastic strip on the front of a Side Window into the channel in the Door Surround. Repeat with both Side Windows.

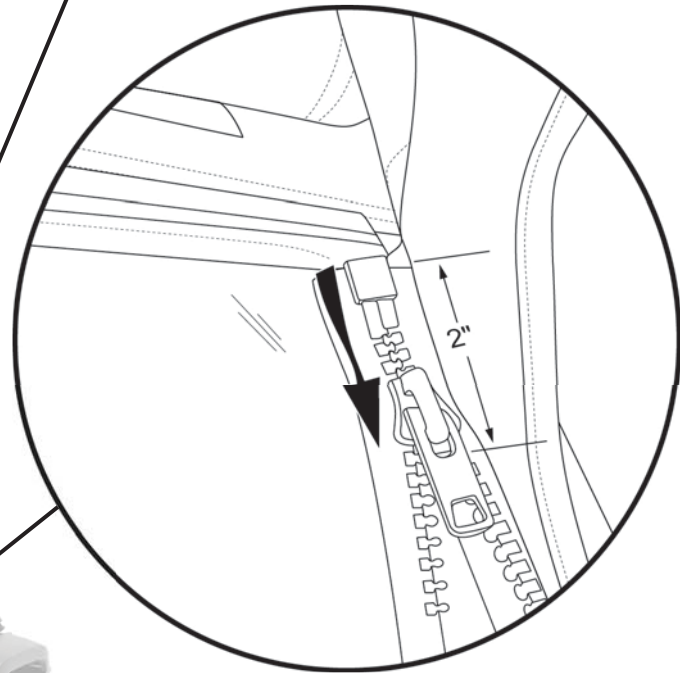

Step Three

Engage the Rear Window zipper with the Quarter Panel zipper. Only close the zipper 1-2".

Repeat on opposite side.



Section 18 Install Side Window (cont.)

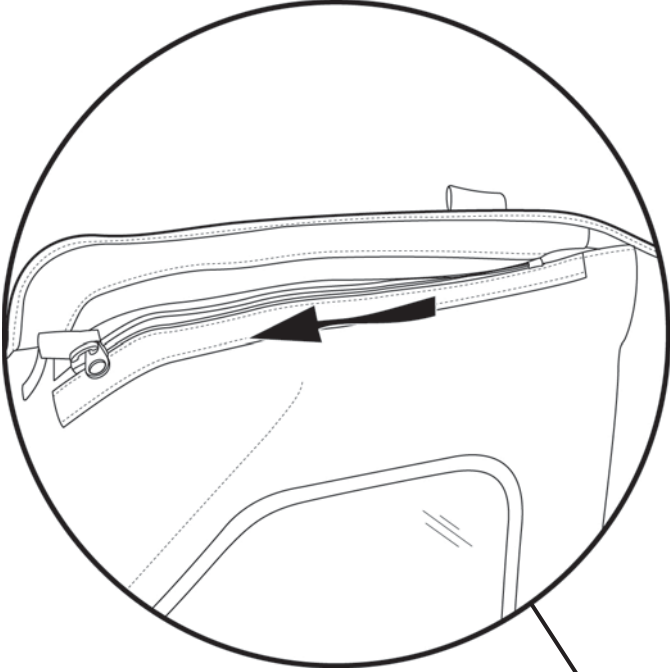

Step Four

Close the zippers along the top of each Side Window.



Step Five

Slip the plastic strip along the bottom of the Side Windows into the channel in the belt rail on each side of the vehicle.

Repeat on opposite side.



Section 19 Install and Secure Tailgate Bar

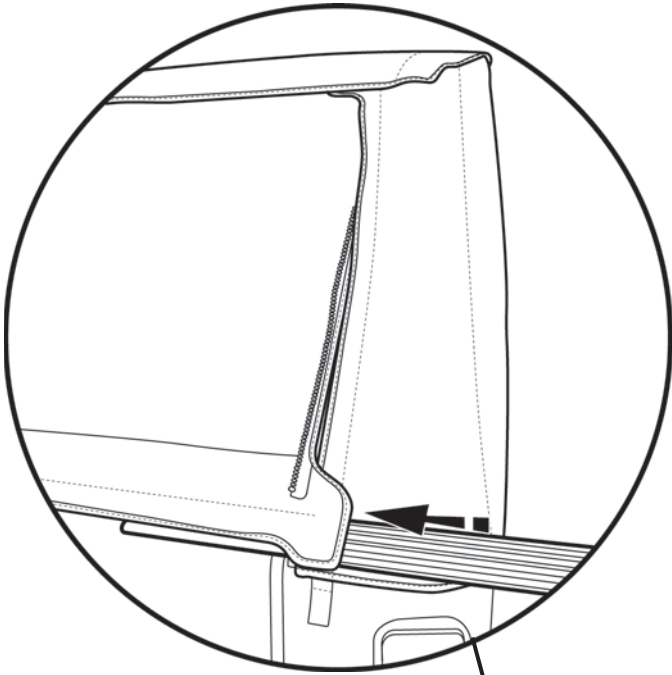

Step One

Slide the channel in the Tailgate Bar onto the tubing along the bottom of the Rear Window on the inside.

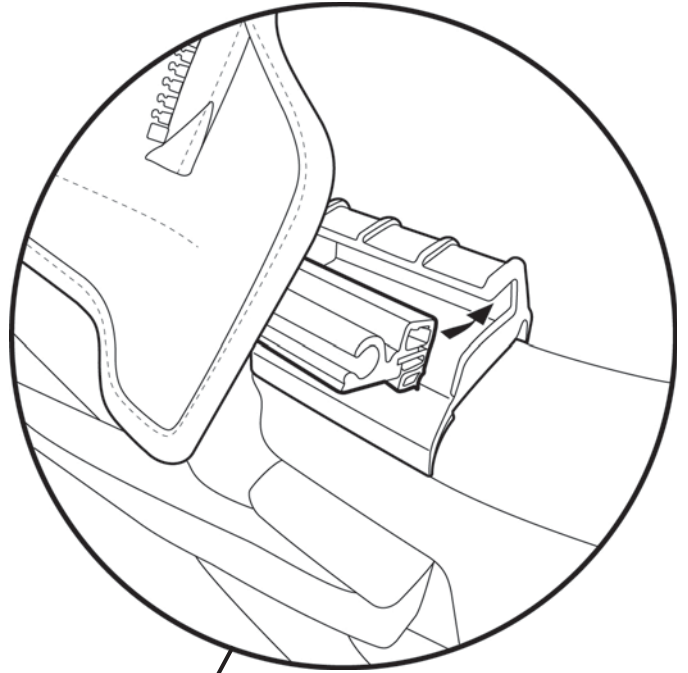

Step Two

Slide the Tailgate Bar into the Tailgate Bar Mounts on each side of the tailgate opening.



Section 20 Secure Rear Window

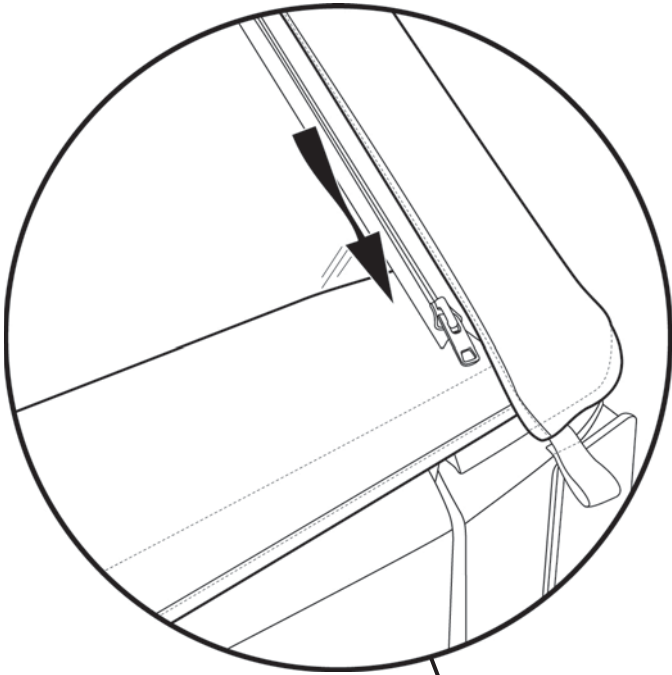

Step One

Close the zippers on both sides of the Rear Window.

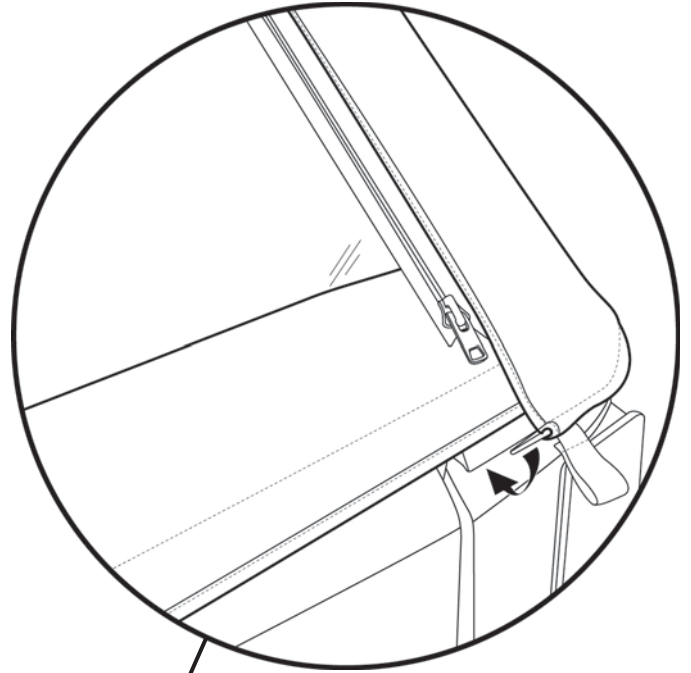

Step Two

Wrap the Side Windows over the Rear Window and slip the plastic strips on each Side Window under the Tailgate Bar Mounts on each side of the tailgate.



Section 21 Secure Header Latches

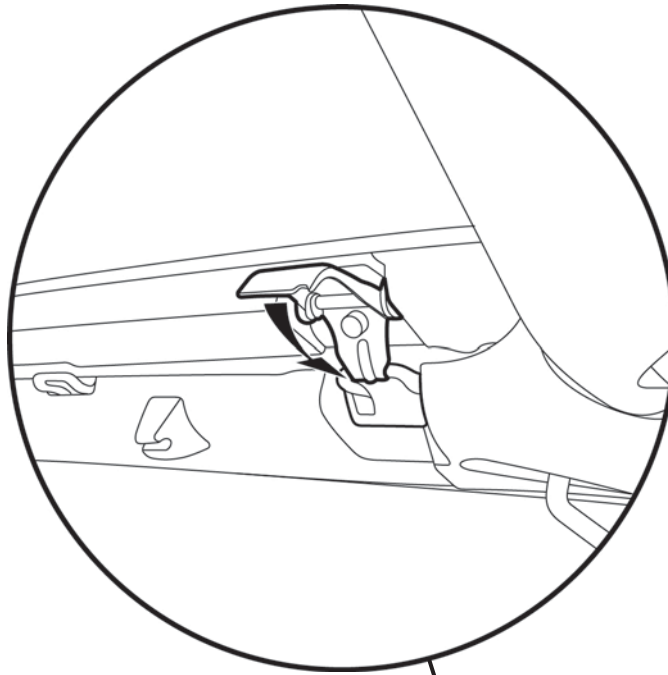

Step One

Hook the latches on the Header into the loops in the windshield and close them.



Section 22 Secure Top Above Door Openings

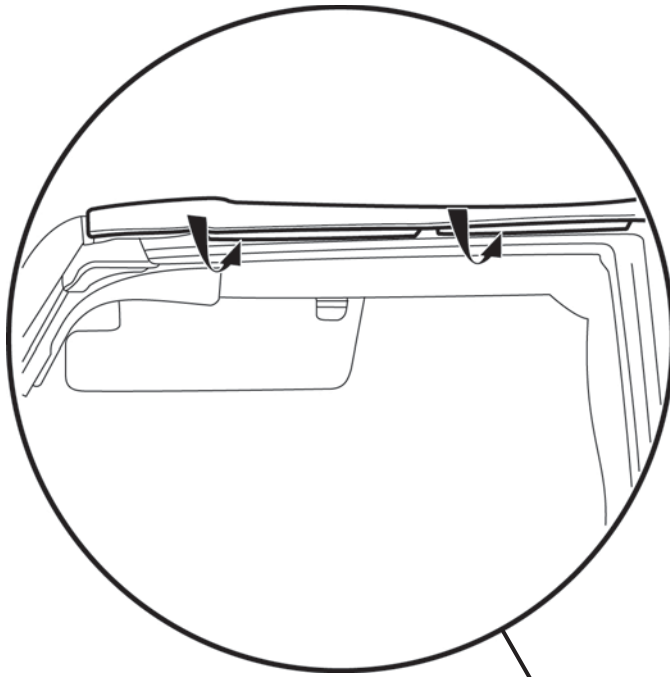

Step One

Slip the plastic strips above the doors into the channel on the vehicle.



Care and Maintenance of your Pavement Ends Product

Your Pavement Ends product is made of the finest materials available. To keep it looking new and for the maximum possible wear, it will need periodic cleaning and maintenance.

Fabric: The fabric should be washed often using soap, warm water and a soft bristle brush. Rinse with clear water to remove all traces of soap. Pavement Ends recommends using Bestop Cleaner (part no. 11201-00) and Bestop Protectant (part no. 11202-00). Bestop Cleaner and Bestop protectant are specially formulated to provide a total cleaning and protection system. Bestop Cleaner safely removes the toughest stains, will not harm vehicle finishes, is biodegradable and environmentally friendly. Bestop Protectant protects against UV-fading, cracking and hardening, and repels dust, grease, dirt and mildew.

Windows: Keep windows clean to avoid scratching. DO NOT use a brush on the windows! Wash with a water-soaked cloth or sponge and a mild dishwashing detergent. Pavement Ends recommends Bestop Vinyl Window Cleaner (part no. 11203-00), which safely cleans and protects vinyl windows and helps prevent UV damage. NEVER WIPE THE WINDOWS WHEN THEY ARE DRY. Be careful when cleaning snow or frost from the vinyl windows since they are easily scratched and may crack at low temperatures. DO NOT roll the sides or rear window in cold weather. The windows become stiff and will crack. Cracks caused by misuse in cold temperatures are not covered under warranty.

Zippers: Keeping zippers cleaned and lubricated with Bestop's Zipper Cleaner (part no. 11206-00) will help prevent damage and keep the zippers in smooth working condition. If a zipper opens behind the slider, the slider may have been spread apart. This problem can usually be repaired by using an ordinary pair of pliers to bring the sides back into parallel. Return slider to the end of the zipper in the normal Open position. Squeeze lightly at first and test the zipper. If the zipper continues to remain open squeeze more firmly with the pliers and try the zipper again. Repeat this procedure until the zipper operates correctly.

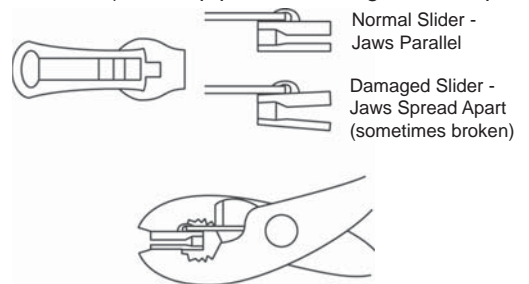

Water: Seeping through at the seams may be stopped by applying 3-M Scotchgard® on the inside of the seams. Rips in the fabric may be repaired with Bondex® iron on patches. Iron the patches to the Inside of the top, carefully following the Bondex® instructions.

Snaps: Keep snaps cleaned and lubricated with silicone to help prevent snaps from sticking to the studs. If a snap does become stuck to a stud, use a screwdriver and GENTLY pry apart to prevent permanent damage to the snap or the top fabric.

LIMITED WARRANTY

We warrant our product to be free from defects in material and workmanship, for terms specified below, provided there has been normal use and proper maintenance. This warranty applies to the original purchaser only. All remedies under this warranty are limited to the repair or replacement of any item or items found by the factory to be defective within the time period specified.

If you have a warranty claim, first you must call our factory at the number below for instructions. You must retain proof of purchase and submit a copy with any items returned for warranty work. Upon completion of warranty work, if any, we will return the repaired or replaced item or items to you freight prepaid. Damage to our products caused by accidents, fire, vandalism, negligence, misinstallation, misuse, Acts of God, or by defective parts not manufactured by us, is not covered under this warranty.

THE WARRANTY TIME PERIOD IS AS FOLLOWS: ALL "GOODS" MANUFACTURED BY OUR COMPANY: THREE (3) YEAR FROM DATE OF PURCHASE.

ANY IMPLIED WARRANTIES OF MERCHANTABILITY AND/OR FITNESS FOR A PARTICULAR PURPOSE CREATED HEREBY ARE LIMITED IN DURATION TO THE SAME DURATION AND SCOPE AS THE EXPRESS WRITTEN WARRANTY. OUR COMPANY SHALL NOT BE LIABLE FOR ANY INCIDENTAL OR CONSEQUENTIAL DAMAGE.