



SUPPLY TUBING

SpacePak's pre-insulated, 2" inside diameter flexible supply tubing is listed by Intertek (ETL), conforming to UL 181 "Factory Made Air Ducts and Connectors, 10th Edition."

UL 181 requirements apply to materials for the fabrication of air duct and air connector systems for use in accordance with the Standards of the National Fire Protection Association for the installation of Air-Conditioning and Ventilating Systems, NFPA No. 90A, and the Installation of Warm Air Heating and Air-Conditioning Systems, NFPA NO. 90B.

Under UL 181, SpacePak supply tubing carries a minimum Class 1 status with a 25/50 flame/smoke spread index. In addition to UL 181, SpacePak supply tubing is compliant with Duct Requirements as identified in the International Building Code.

Manufactured in Farmville, NC at the SpacePak plant, the fully assembled supply tubing is available in insulation R-values of R6.0 and R8.0, as rated by ASHRAE Fundamentals 2005. The core is made up of a three-ply, corrugated flexible aluminum, resulting in a 2" inside diameter. The insulation surrounding the core is Flex-Glas PC formaldehyde-free, lightweight, highly resilient, blanket-type material that provides excellent thermal and acoustical performance. Insulation and core are cleanly contained in a Mylar sheath that is secured with a duct closure tape rated (UL 181B-FX) for operation in a wide range of temperatures and humidity conditions.

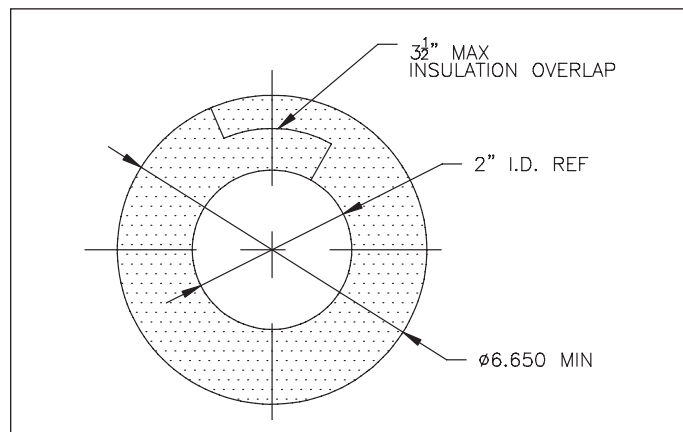

R8 shown.



- Listed by ETL; conforms to UL 181
- Rated Pressure: 0.0 – 2.5" W.C.
- Rated Velocity: Maximum 2,500 F.P.M
- Available in R6 and R8 insulation values
- R6 approx. total diameter: 3.75"
- R8 approx. total diameter: 7"
- Resistant to fungi growth
- Class 1, 25/50 flame/smoke spread
- Insulation meets Surface Burning Characteristics & Limited Combustibility per UL 723, NFPA 90A & 90B, ASTM E84, CAN/ULC S102-1188
- Max. Operating Temperature: 250°F
- Meets "Buy American Act" standards for ARRA 2009
- Manufactured and assembled in USA
- Duct closure tape min to max temperature range: -37°F to 260°F
- SCS Certified for Green Building Recycled Content