

PRO-FORM[®]

PERFORMANCE 1250

Model No. PETL12711.0

Serial No. _____

Write the serial number in the space above for reference.

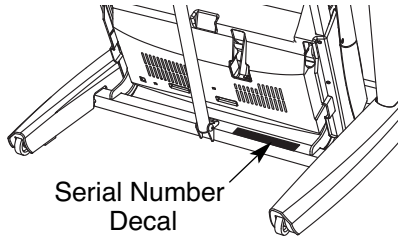

USER'S MANUAL

QUESTIONS?

If you have questions, or if there are missing parts, please contact us:

UK

Call: 08457 089 009

From Ireland: 053 92 36102

Website: www.iconsupport.eu

E-mail: csuk@iconeurope.com

Write:

ICON Health & Fitness, Ltd.

c/o HI Group PLC

Express Way

Whitwood, West Yorkshire

WF10 5QJ

UK

AUSTRALIA

Call: 1-800-237-173

E-mail:

australiacc@iconfitness.com

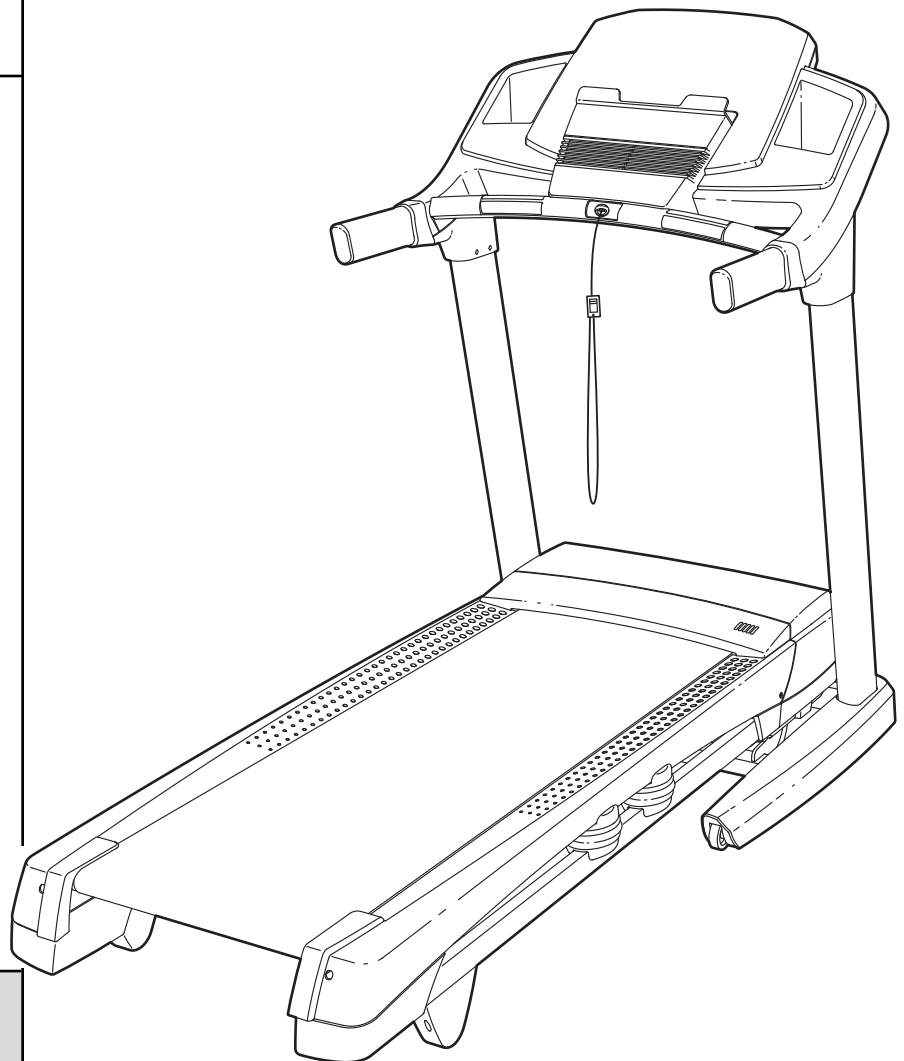

⚠ CAUTION

Read all precautions and instructions in this manual before using this equipment. Save this manual for future reference.

TABLE OF CONTENTS



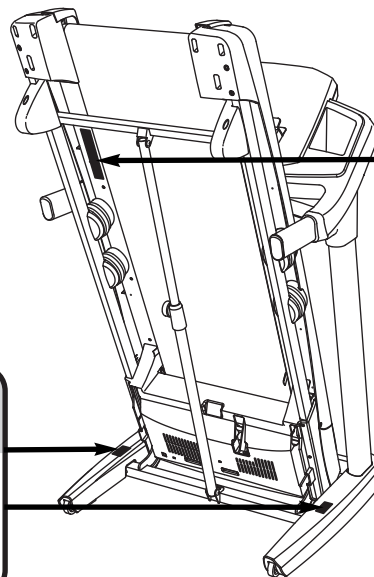

WARNING DECAL PLACEMENT2
IMPORTANT PRECAUTIONS3
BEFORE YOU BEGIN5
PART IDENTIFICATION CHART6
ASSEMBLY7
THE CHEST HEART RATE MONITOR15
OPERATION AND ADJUSTMENT16
HOW TO FOLD AND MOVE THE TREADMILL25
TROUBLESHOOTING26
EXERCISE GUIDELINES29
PART LIST30
EXPLODED DRAWING32
ORDERING REPLACEMENT PARTS	Back Cover
RECYCLING INFORMATION	Back Cover

WARNING DECAL PLACEMENT

This drawing shows the locations of the warning decals. **If a decal is missing or illegible, call the telephone number on the front cover of this manual and request a free replacement decal. Apply the decal in the location shown.** Note: The decals may not be shown at actual size.



▲WARNING:
Protect yourself and others from risk of serious injury. Read the user's manual and :

-  •Stand only on the side rails when starting or stopping treadmill.
- Change speed in small increments.
- Hold handrails to prevent falling, and always wear the safety clip while operating treadmill.
- Stop if you feel faint, dizzy, or short of breath.
- Fully engage storage latch before treadmill is moved or stored.
- Reduce incline to its lowest level before folding treadmill into storage position.
-  •Never allow children on or around treadmill.
- Remove key when not in use.
-  •Keep clothing, fingers, and hair away from moving belt.
- Never try to adjust or fix the belt while it is moving.
-  •Always wear athletic shoes while operating treadmill.

PROFORM is a registered trademark of ICON IP, Inc.
 iPod, iPod nano, iPod touch, and iTunes are registered trademarks of Apple Inc., registered in the U.S. and other countries. iPod® is not included.
 Nike is a registered trademark of NIKE, Inc. and its affiliated companies.

IMPORTANT PRECAUTIONS

⚠ WARNING: To reduce the risk of serious injury, read all important precautions and instructions in this manual and all warnings on your treadmill before using your treadmill. ICON assumes no responsibility for personal injury or property damage sustained by or through the use of this product.

1. Before beginning any exercise program, consult your physician. This is especially important for persons over age 35 or persons with pre-existing health problems.
2. It is the responsibility of the owner to ensure that all users of this treadmill are adequately informed of all warnings and precautions.
3. Use the treadmill only as described.
4. Keep the treadmill indoors, away from moisture and dust. Do not put the treadmill in a garage or covered patio, or near water.
5. Place the treadmill on a level surface, with at least 8 ft. (2.4 m) of clearance behind it and 2 ft. (0.6 m) on each side. Do not place the treadmill on any surface that blocks air openings. To protect the floor or carpet from damage, place a mat under the treadmill.
6. Do not operate the treadmill where aerosol products are used or where oxygen is being administered.
7. Keep children under age 12 and pets away from the treadmill at all times.
8. The treadmill should be used only by persons weighing 330 lbs. (150 kg) or less.
9. Never allow more than one person on the treadmill at a time.
10. Wear appropriate exercise clothes when using the treadmill. Do not wear loose clothes that could become caught in the treadmill. Athletic support clothes are recommended for both men and women. *Always wear athletic shoes. Never use the treadmill with bare feet, wearing only stockings, or in sandals.*
11. When connecting the power cord (see page 16), plug the power cord into an earthed circuit. No other appliance should be on the same circuit. When replacing the fuse in the power cord adapter, insert an ASTA-approved BS1362, 13-amp fuse into the fuse carrier.
12. If an extension cord is needed, use only a 3-conductor, 14-gauge (1 mm²) cord that is no longer than 5 ft. (1.5 m).
13. Keep the power cord away from heated surfaces.
14. Never move the walking belt while the power is turned off. Do not operate the treadmill if the power cord or plug is damaged, or if the treadmill is not working properly. (See TROUBLESHOOTING on page 26 if the treadmill is not working properly.)
15. Read, understand, and test the emergency stop procedure before using the treadmill (see HOW TO TURN ON THE POWER on page 18).
16. Never start the treadmill while you are standing on the walking belt. Always hold the handrails while using the treadmill.
17. The treadmill is capable of high speeds. Adjust the speed in small increments to avoid sudden jumps in speed.
18. The heart rate monitor is not a medical device. Various factors, including the user's movement, may affect the accuracy of heart rate readings. The heart rate monitor is intended only as an exercise aid in determining heart rate trends in general.

19. Never leave the treadmill unattended while it is running. Always remove the key, unplug the power cord, and press the power switch into the off position when the treadmill is not in use. (See the drawing on page 5 for the location of the power switch.)
20. Do not attempt to raise, lower, or move the treadmill until it is properly assembled. (See ASSEMBLY on page 7, and HOW TO FOLD AND MOVE THE TREADMILL on page 25.) You must be able to safely lift 45 lbs. (20 kg) to raise, lower, or move the treadmill.
21. When folding or moving the treadmill, make sure that the storage latch is holding the frame securely in the storage position.
22. Never insert any object into any opening on the treadmill.
23. Inspect and properly tighten all parts of the treadmill regularly.
24. **DANGER:** Always unplug the power cord immediately after use, before cleaning the treadmill, and before performing the maintenance and adjustment procedures described in this manual. Never remove the motor hood unless instructed to do so by an authorized service representative. Servicing other than the procedures in this manual should be performed by an authorized service representative only.
25. This treadmill is intended for in-home use only. Do not use this treadmill in a commercial, rental, or institutional setting.
26. Over exercising may result in serious injury or death. If you feel faint or if you experience pain while exercising, stop immediately and cool down.

SAVE THESE INSTRUCTIONS

BEFORE YOU BEGIN

Thank you for selecting the revolutionary PROFORM® PERFORMANCE 1250 treadmill. The PERFORMANCE 1250 treadmill offers an impressive selection of features designed to make your workouts at home more enjoyable and effective. And when you're not exercising, the unique treadmill can be folded up, requiring less than half the floor space of other treadmills.

For your benefit, read this manual carefully before using the treadmill. If you have questions after read-

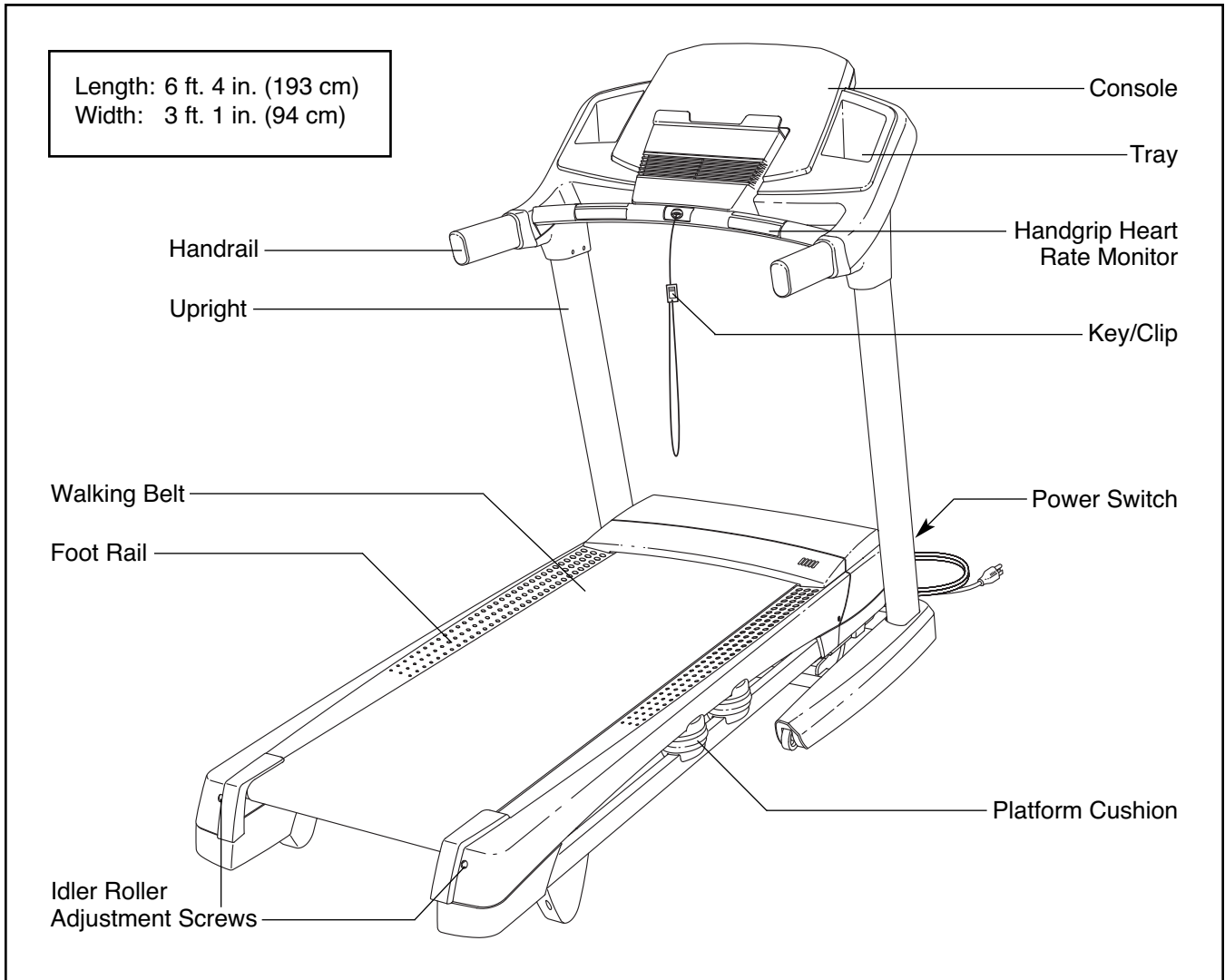

ing this manual, please see the front cover of this manual. To help us assist you, please note the product model number and serial number before contacting us. The model number and the location of the serial number decal are shown on the front cover of this manual.

Before reading further, please review the drawing below and familiarize yourself with the labeled parts.



PART IDENTIFICATION CHART

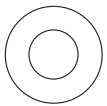
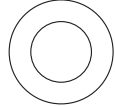
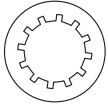
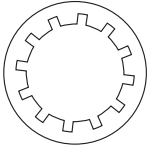
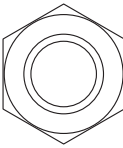
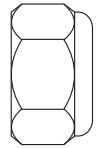
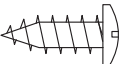
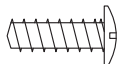
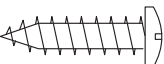
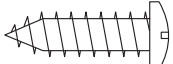

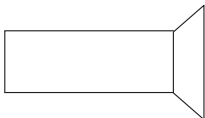
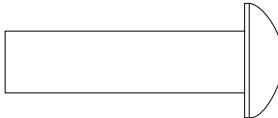
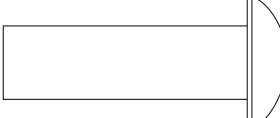
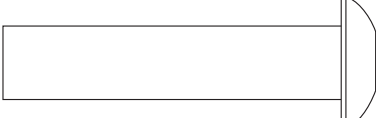
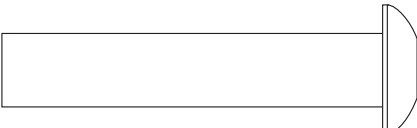
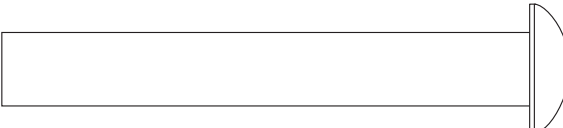

Use the drawings below to identify small parts used for assembly. The number in parentheses below each drawing is the key number of the part, from the PART LIST near the end of this manual. The number following the key number is the quantity used for assembly. **Note: If a part is not in the hardware kit, check to see if it is preattached. Some extra hardware may be included.**

						
1/4" Star Washer (35)-2	1/4" Flat Washer (36)-2	5/16" Flat Washer (113)-4	5/16" Star Washer (11)-8	3/8" Star Washer (13)-4	3/8" Nut (12)-2	
						
#8 x 1/2" Screw (1)-16	#8 x 1/2" Ground Screw (10)-1	#8 x 3/4" Screw (2)-6	#10 x 3/4" Screw (9)-2	#10 x 3/4" Flat Head Screw (112)-2		
						
5/16" x 1" Screw (5)-4	5/16" x 1 1/4" Screw (4)-6	3/8" x 1 1/4" Screw (8)-4	3/8" x 1 3/4" Bolt (6)-1			
						
	3/8" x 2" Bolt (3)-1	3/8" x 2 3/4" Screw (7)-4				

ASSEMBLY

- Assembly requires two persons.
- Place all parts in a cleared area and remove the packing materials. Do not dispose of the packing materials until you finish assembly.
- The underside of the walking belt is coated with high-performance lubricant. After shipping, there may be some lubricant on top of the walking belt or on the shipping carton. This is normal. If there is lubricant on top of the walking belt, wipe it off with a soft cloth and a mild, non-abrasive cleaner.
- To identify small parts, see page 6.

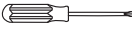
- Assembly requires the following tools:

- the included hex keys 
- one adjustable wrench 
- one Phillips screwdriver 
- scissors 

To avoid damaging parts, do not use power tools for assembly.

1. Make sure that the power cord is unplugged.

Place a piece of cardboard below the rear of the Frame (56) to protect the floor or carpet.

Attach the Left Wheel Cap (96) to the Base (94) with two #8 x 3/4" Screws (2).

Attach the Right Wheel Cap (not shown) to the right side of the Base (94) in the same way.

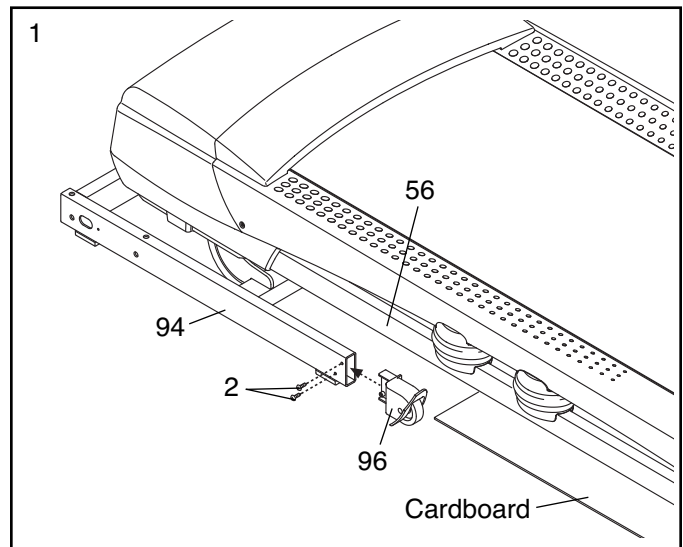

2. Pull the Upright Wire (81) and the Base Ground Wire (110) through the indicated hole in the Base (94).

Attach the Base Ground Wire (110) to the Base (94) with a #8 x 1/2" Ground Screw (10).

Press the Grommet (77) into the square hole in the Base (94).

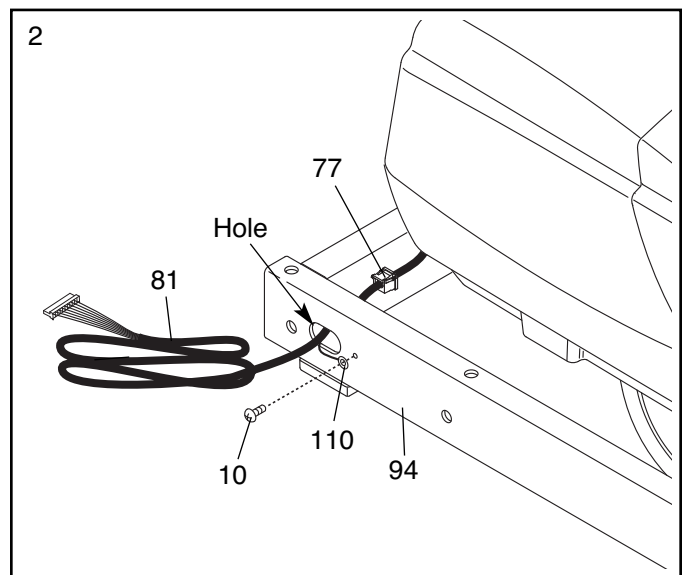

3. Identify the Left Upright (89), which is marked "Left." Have a second person hold the Left Upright near the Base (94).

See the inset drawing. Tie the wire tie in the Left Upright (89) securely around the end of the Upright Wire (81). Then, pull the other end of the wire tie until the Upright Wire is routed through the Left Upright.

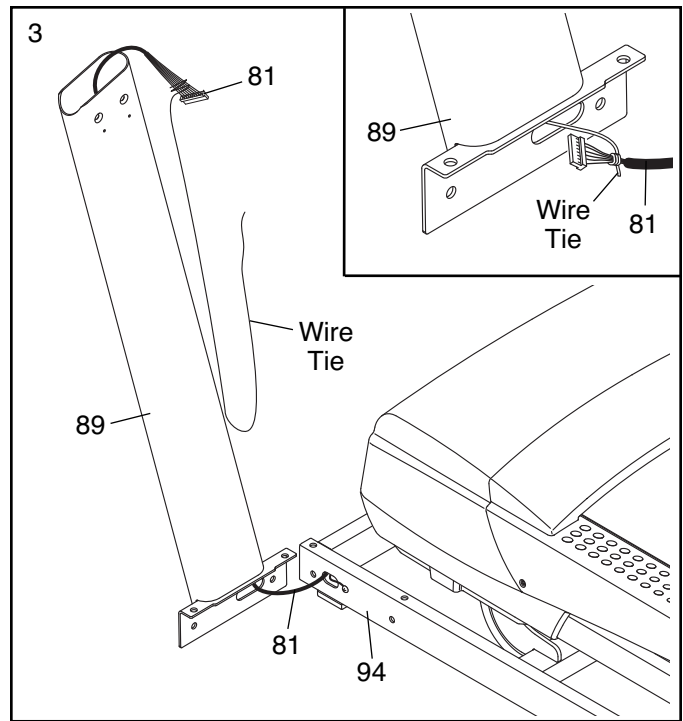

4. Hold the Left Upright (89) against the Base (94). **Be careful not to pinch the Upright Wire (81).** Partially tighten two 3/8" x 1 1/4" Screws (8) with two 3/8" Star Washers (13) and two 3/8" x 2 3/4" Screws (7) into the Left Upright until the heads of the Screws touch the Left Upright. **Do not fully tighten the Screws yet.**

Attach the Right Upright (not shown) in the same way. Note: There are no wires on the right side.

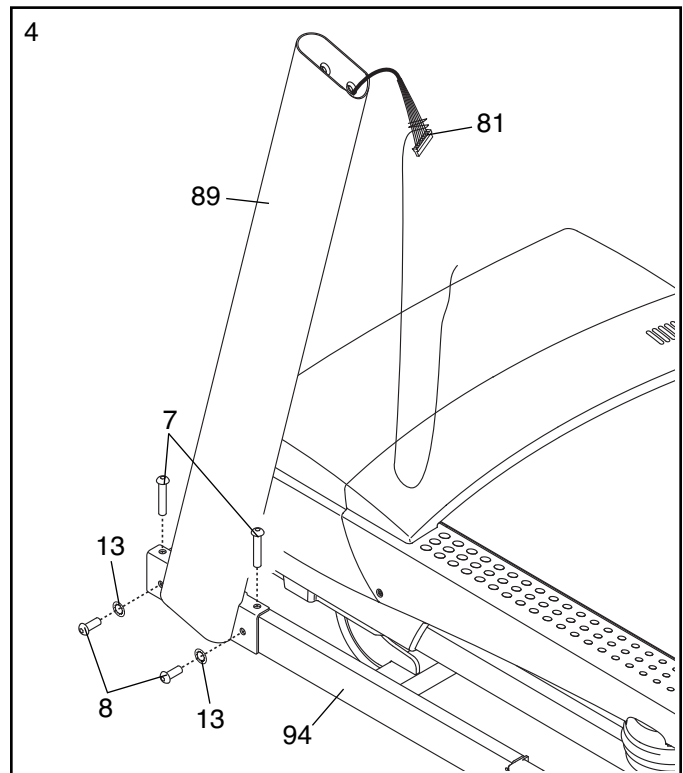

5. Identify the Left and Right Base Covers (82, 83). Slide the Left Base Cover onto the Left Upright (89). Slide the Right Base Cover onto the Right Upright (90). **Do not press the Base Covers into place yet.**

Identify the Left and Right Upright Covers (79, 80). Slide the Left Upright Cover onto the Left Upright (89). Slide the Right Upright Cover onto the Right Upright (90).

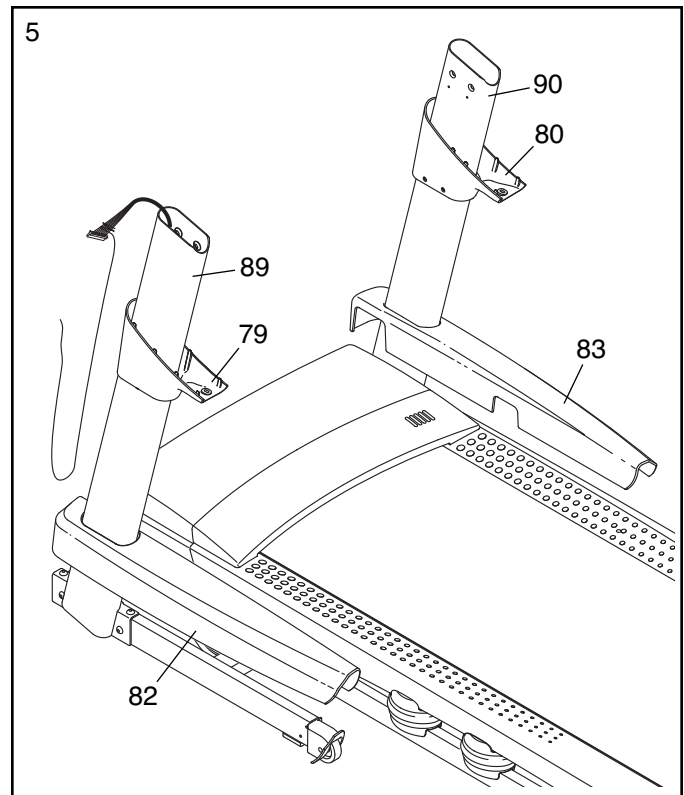

6. Cut the plastic tie in the Left Handrail (88) and the Right Handrail (not shown). If necessary, press the 5/16" Cage Nuts (31) back into place (only one is shown).

Identify the Left Handrail (88) and hold it near the Left Upright (89). Insert the Upright Wire (81) through the bracket on the bottom of the Left Handrail. Pull the Upright Wire out of the end of the Left Handrail.

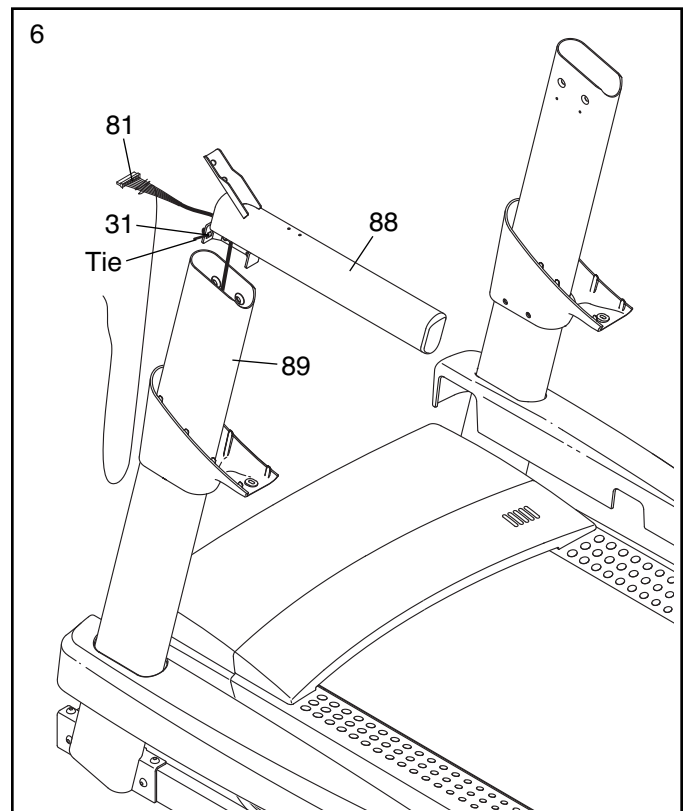

7. Attach the Left Handrail (88) to the Left Upright (89) with two 5/16" x 1" Screws (5), two 5/16" Star Washers (11), and a 5/16" x 1 1/4" Screw (4). **Do not fully tighten the Screws yet.**

Attach the Right Handrail (87) in the same way.

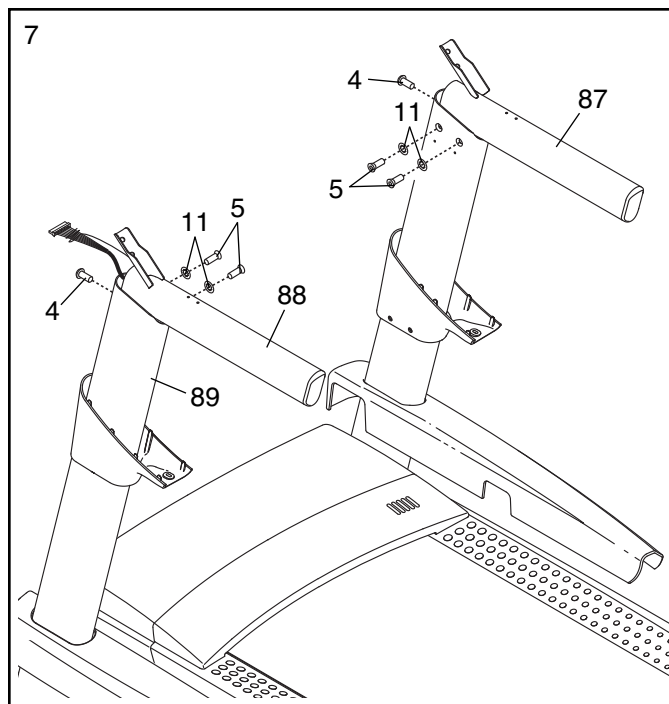

8. Set the console assembly face down on a soft surface to avoid scratching the console assembly. Remove the two Screws (A). Next, lift off the Crossbar (93). Discard the two Screws.

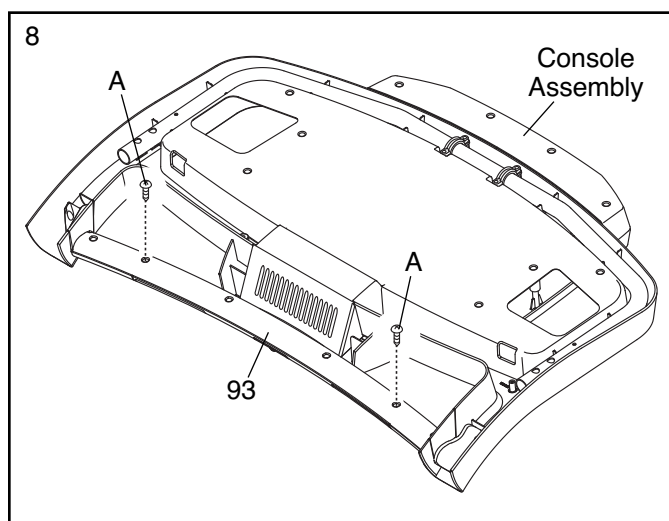

9. **IMPORTANT: To avoid damaging the Crossbar (93), do not use power tools and do not overtighten the #10 x 3/4" Screws (9) or the #10 x 3/4" Flat Head Screws (112).**

Orient the Crossbar (93) as shown. Attach the Crossbar to the Handrails (87, 88) with two #10 x 3/4" Flat Head Screws (112), two #10 x 3/4" Screws (9), and two 1/4" Star Washers (35) as shown. **Start all four Screws, and then tighten each of them.**

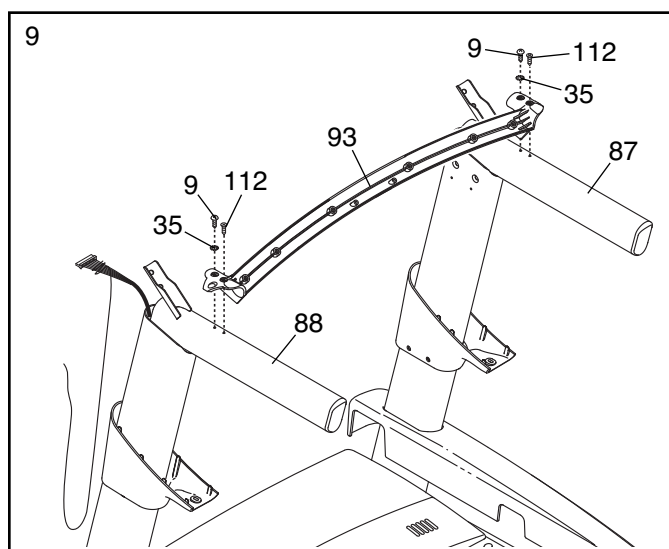

10. With the help of a second person, hold the console assembly near the Left Handrail (88).

Connect the Upright Wire (81) to the console wire. **See the inset drawing. The connectors should slide together easily and snap into place.** If they do not, turn one connector and try again. **IF YOU DO NOT CONNECT THE CONNECTORS PROPERLY, THE CONSOLE MAY BECOME DAMAGED WHEN YOU TURN ON THE POWER.** Remove the wire tie from the Upright Wire.

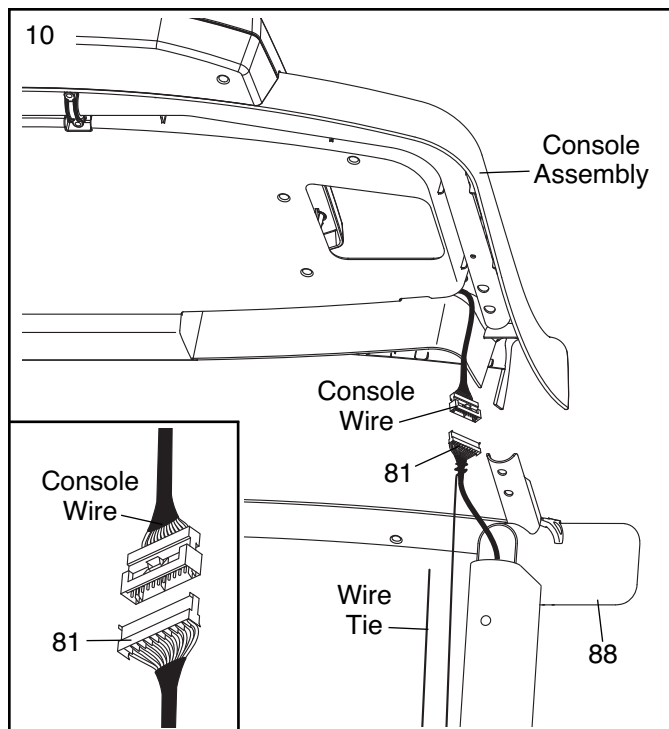

11. Set the console assembly on the Right and Left Handrails (87, 88). **Be careful not to pinch any wires.** Insert the excess Upright Wire (not shown) into the Left Handrail.

Attach the console assembly with six #8 x 1/2" Screws (1), four 5/16" x 1 1/4" Screws (4), four 5/16" Flat Washers (113), and four 5/16" Star Washers (11). **Start all ten Screws, and then tighten each of them.**

See step 7. Fully tighten the four 5/16" x 1" Screws (5) and the two 5/16" x 1 1/4" Screws (4).

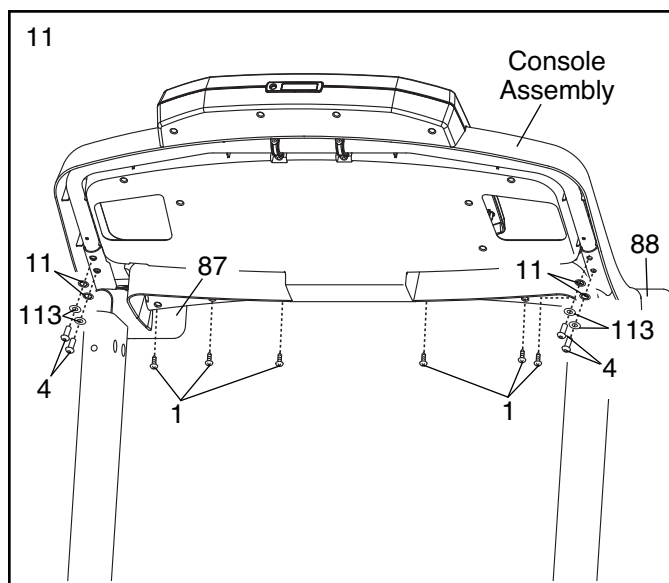

12. Firmly tighten the four the 3/8" x 2 3/4" Screws (7) and then the four 3/8" x 1 1/4" Screws (8) (only one side is shown).

Press the Left and Right Base Covers (82, 83) onto the Base (94) until they snap into place.

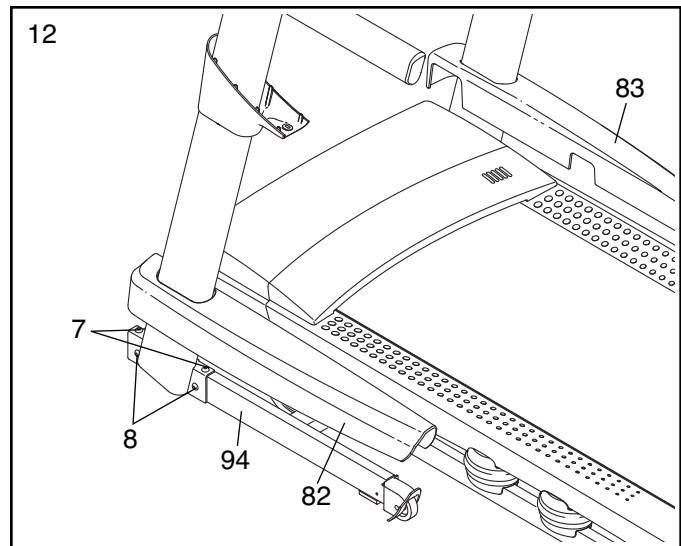

13. Slide the Left Handrail Cover (85) onto the Left Handrail (88). Slide the Right Handrail Cover (86) onto the Right Handrail (87). Attach the Handrail Covers with two #8 x 1/2" Screws (1).

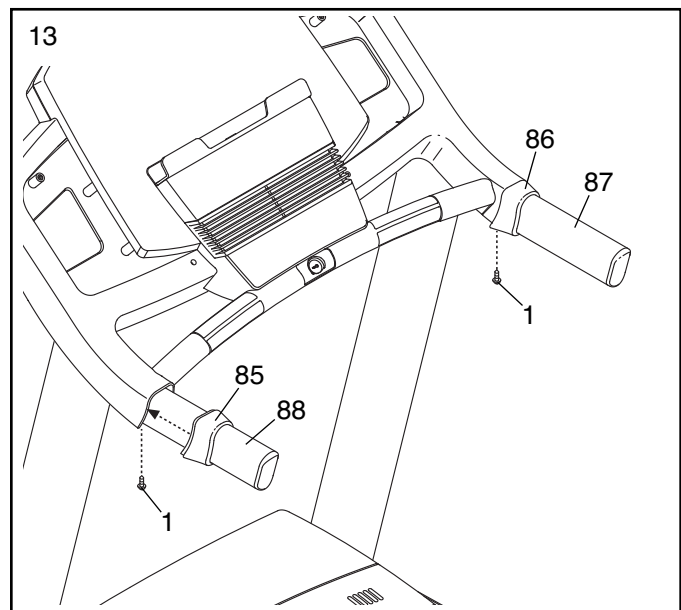

14. Hold the Left Upright Cover (79) against the console assembly. Align the holes in the Left Upright Cover with the holes in the Left Upright (89). Attach the Left Upright Cover with two #8 x 1/2" Screws (1), a #8 x 3/4" Screw (2), and a 1/4" Flat Washer (36) as shown.

Attach the Right Upright Cover (80) to the Right Upright (90) in the same way.

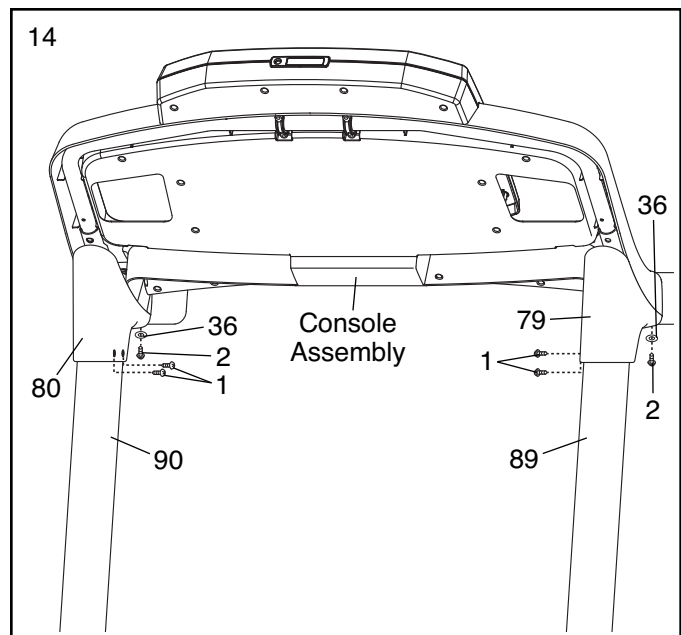

15. Attach the Left and Right Trays (107, 108) to the console assembly with four #8 x 1/2" Screws (1).

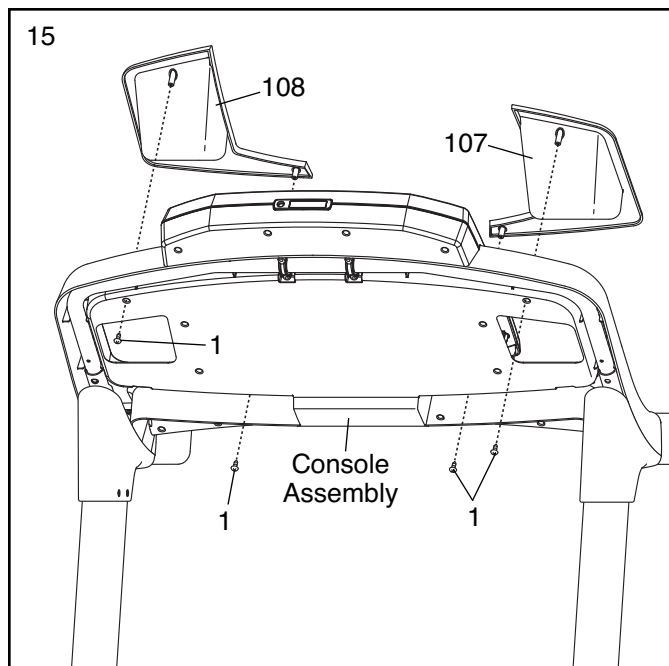

16. Next, raise the Frame (56) to the position shown. **Have a second person hold the Frame until step 17 is completed.**

Orient the Storage Latch (53) so that the large barrel and the latch knob are oriented as shown.

Attach the lower end of the Storage Latch (53) to the Base (94) with a 3/8" x 2" Bolt (3) and a 3/8" Nut (12).

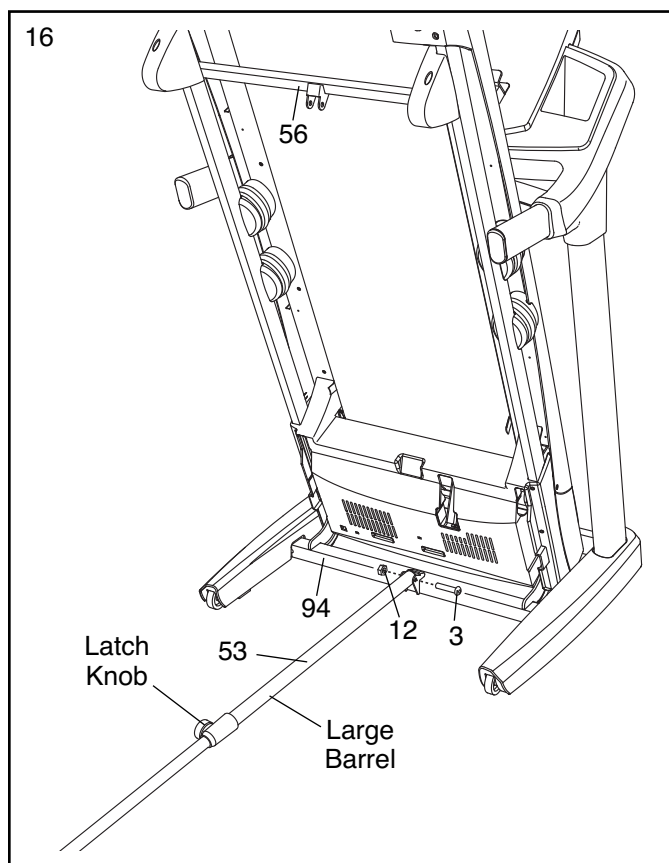

17. Attach the upper end of the Storage Latch (53) to the Frame (56) with a 3/8" x 1 3/4" Bolt (6) and a 3/8" Nut (12). Note: It may be necessary to move the Frame back and forth to align the Storage Latch with the Frame.

Lower the Frame (56) (see HOW TO LOWER THE TREADMILL FOR USE on page 25).

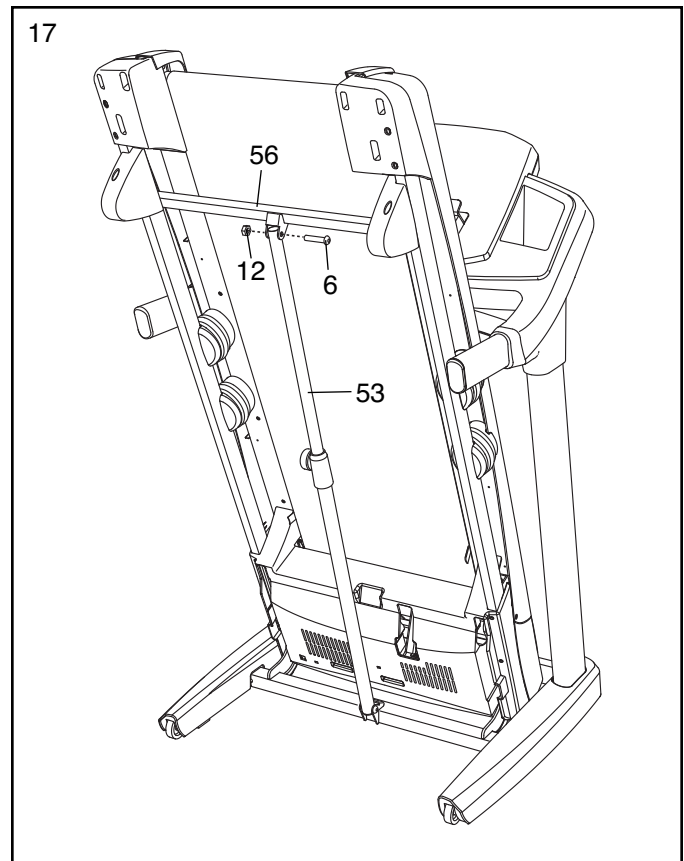

18. **Make sure that all parts are properly tightened before you use the treadmill.** If there are sheets of plastic on the treadmill decals, remove the plastic. To protect the floor or carpet, place a mat under the treadmill. Note: Extra hardware may be included. Keep the included hex keys in a secure place; one of the hex keys is used to adjust the walking belt (see pages 27 and 28).

THE CHEST HEART RATE MONITOR

HOW TO PUT ON THE HEART RATE MONITOR

The heart rate monitor consists of a chest strap and a sensor. Insert the tab on one end of the chest strap into the hole in one end of the sensor as shown. Then, press the end of the sensor under the buckle on the chest strap. The tab should be flush with the front of the sensor.

The heart rate monitor must be worn under your clothes, tight against your skin. Wrap the heart rate monitor around your chest in the location shown. Make sure that the logo is right-side-up. Then, attach the other end of the chest strap to the sensor. Adjust the length of the chest strap, if necessary.

Pull the sensor away from your body a few inches and locate the two electrode areas, which are covered by shallow ridges. Using saline solution such as saliva or contact lens solution, wet the electrode areas. Then, return the sensor to a position against your chest.

CARE AND MAINTENANCE

- Thoroughly dry the sensor with a soft towel after each use. Moisture may keep the sensor activated, shortening the life of the battery.
- Store the heart rate monitor in a warm, dry place. Do not store the heart rate monitor in a plastic bag or other container that may trap moisture.

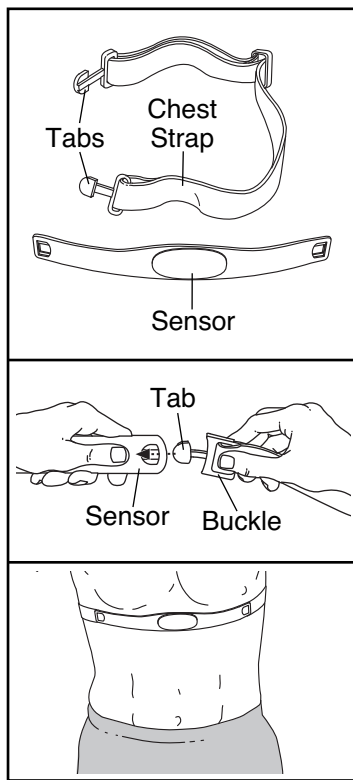

- Do not expose the heart rate monitor to direct sunlight for extended periods of time; do not expose it to temperatures above 122° F (50° C) or below 14° F (-10° C).
- Do not excessively bend or stretch the sensor when using or storing the heart rate monitor.
- To clean the sensor, use a damp cloth and a small amount of mild soap. Then, wipe the sensor with a damp cloth and thoroughly dry it with a soft towel. Never use alcohol, abrasives, or chemicals to clean the sensor. Hand wash and air dry the chest strap.

TROUBLESHOOTING

If the heart rate monitor does not function properly, try the steps below.

- Make sure that you are wearing the heart rate monitor as described at the left. If the heart rate monitor does not function when positioned as described, move it slightly lower or higher on your chest.
- If heart rate readings are not displayed until you begin perspiring, rewet the electrode areas.
- For the console to display heart rate readings, you must be within arm's length of the console.
- If there is a battery cover on the back of the sensor, replace the battery with a new battery of the same type.
- The heart rate monitor is designed to work with people who have normal heart rhythms. Heart rate reading problems may be caused by medical conditions such as premature ventricular contractions (pvc's), tachycardia bursts, and arrhythmia.
- The operation of the heart rate monitor can be affected by magnetic interference from high power lines or other sources. If you suspect that magnetic interference is causing a problem, try relocating the fitness equipment.

OPERATION AND ADJUSTMENT

HOW TO PLUG IN THE POWER CORD

This product must be earthed. If it should malfunction or break down, earthing provides a path of least resistance for electric current to reduce the risk of electric shock. This product's power cord has an equipment-earthing conductor and an earthing plug.

IMPORTANT: If the power cord is damaged, it must be replaced with a manufacturer-recommended power cord.

⚠ DANGER: Improper connection of the equipment-earthing conductor can result in an increased risk of electric shock. Check with a qualified electrician or serviceman if you are in doubt as to whether the product is properly earthed. Do not modify the plug provided with the product—if it will not fit the outlet, have a proper outlet installed by a qualified electrician.

Follow the steps below to plug in the power cord.

1. Plug the indicated end of the power cord into the socket on the treadmill.

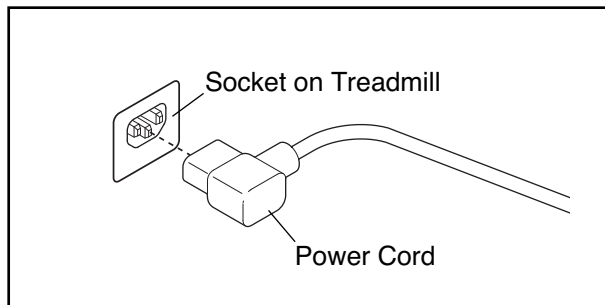

2. Plug the power cord into an appropriate outlet that is properly installed and earthed in accordance with all local codes and ordinances.

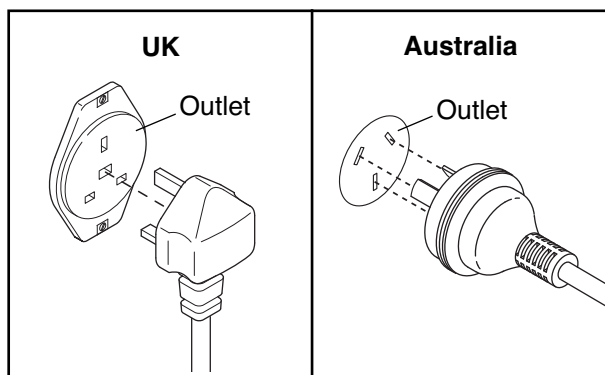

CONSOLE DIAGRAM

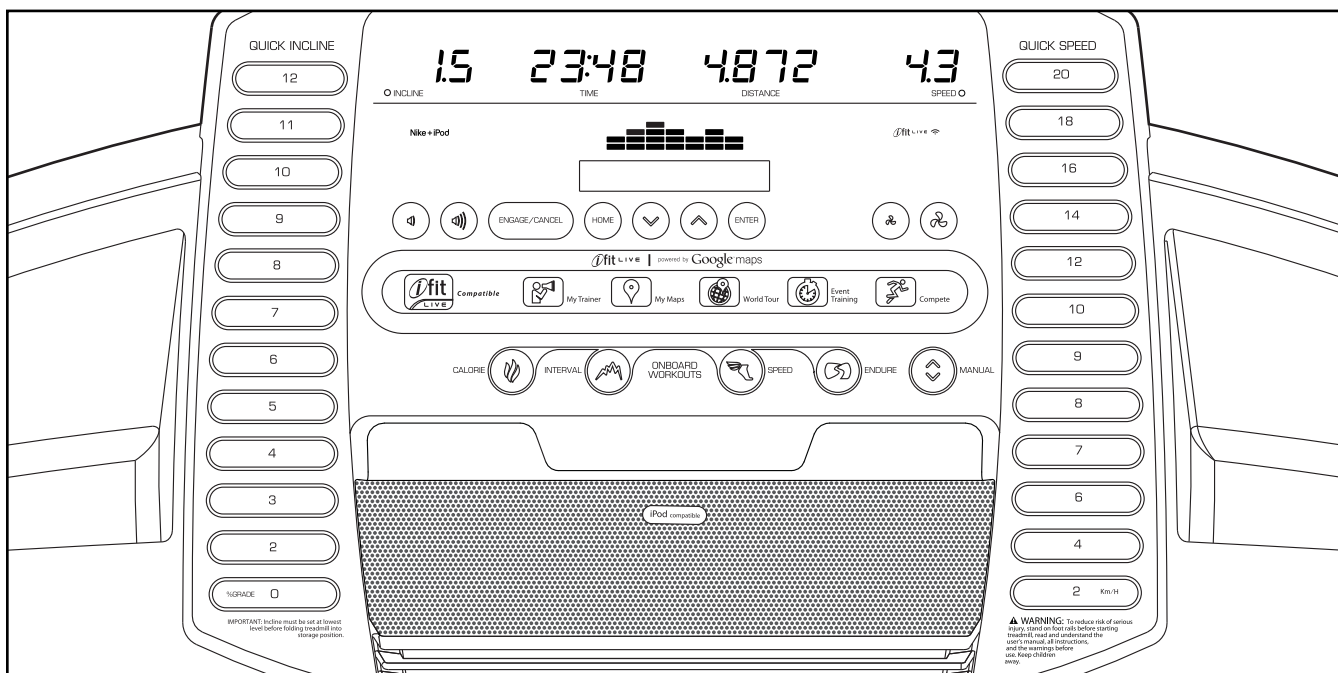

FEATURES OF THE CONSOLE

The treadmill console offers an impressive array of features designed to make your workouts more effective and enjoyable. When you use the manual mode, you can change the speed and incline of the treadmill with the touch of a button. As you exercise, the console will display instant exercise feedback. You can even measure your heart rate using the handgrip heart rate monitor or the chest heart rate monitor.

In addition, the console features sixteen onboard workouts—four calorie workouts, four interval workouts, four speed workouts, and four endurance workouts. Each workout automatically controls the speed and incline of the treadmill as it guides you through an effective exercise session.

The console also features an iFit Live mode that enables the treadmill to communicate with your wireless network through an optional iFit Live module. With the iFit Live mode, you can download personalized workouts, create your own workouts, track your workout results, race against other runners, and access many other features. **To purchase an iFit Live module at any time, go to www.iFit.com or call the telephone number on the front cover of this manual.**

You can also connect to Nikeplus.com through the optional PROFORM SYNC. With the SYNC, you can use an array of tools to analyze your results and monitor

your progress toward your fitness goals. **To purchase a SYNC at any time, call the telephone number on the front cover of this manual.**

You can even listen to your favorite workout music or audio books with the console's stereo sound system while you exercise. This treadmill has been designed specifically to work with iPod and has been certified by the developer to meet Apple performance standards.

To turn on the power, see page 18. To use the manual mode, see page 18. To use an onboard workout, see page 21. To use an iFit Live workout, see page 22. To use the information mode, see page 23. To use the stereo sound system, see page 24. To use a PROFORM SYNC, see page 24.

Note: The console can display speed and distance in either miles or kilometers. To find which unit of measurement is selected, see THE INFORMATION MODE on page 23. For simplicity, all instructions in this manual refer to kilometers.

IMPORTANT: If there are sheets of plastic on the console, remove the plastic. To prevent damage to the walking platform, wear clean athletic shoes while using the treadmill. The first time you use the treadmill, observe the alignment of the walking belt, and center the walking belt if necessary (see page 28).

HOW TO TURN ON THE POWER

IMPORTANT: If the treadmill has been exposed to cold temperatures, allow it to warm to room temperature before turning on the power. If you do not do this, you may damage the console displays or other electrical components.

Plug in the power cord (see page 16). Next, locate the power switch on the treadmill frame near the power cord. Press the power switch into the reset position.

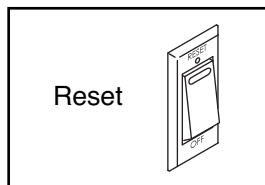

IMPORTANT: The console features a display demo mode, designed to be used if the treadmill is displayed in a store. If the displays light as soon as you plug in the power cord and press the power switch into the reset position, the demo mode is turned on. To turn off the demo mode, hold down the Stop button for a few seconds. If the displays remain lit, see THE INFORMATION MODE on page 23 to turn off the demo mode.

Next, stand on the foot rails of the treadmill. Find the clip attached to the key and slide the clip onto the waistband of your clothes. Then, insert the key into the console.

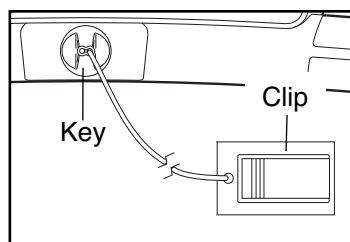

After a moment, the displays will light. **IMPORTANT:** In an emergency, the key can be pulled from the console, causing the walking belt to slow to a stop. Test the clip by carefully taking a few steps backward; if the key is not pulled from the console, adjust the position of the clip.

HOW TO USE THE MANUAL MODE

1. Insert the key into the console.

See HOW TO TURN ON THE POWER at the left.

2. Select the manual mode.

If the manual mode is not selected, press the Manual button on the console.

3. Start the walking belt.

To start the walking belt, press the Start button, the Speed increase button, or one of the numbered Quick Speed buttons.

If you press the Start button or the Speed increase button, the walking belt will begin to move at 2 Km/H. As you exercise, change the speed of the walking belt as desired by pressing the Speed increase and decrease buttons. Each time you press one of the buttons, the speed setting will change by 0.1 Km/H; if you hold down the button, the speed setting will change in increments of 0.5 Km/H. Note: After you press the button, it may take a moment for the walking belt to reach the selected speed setting.

If you press one of the numbered Quick Speed buttons, the walking belt will gradually change speed until it reaches the selected speed setting. To select a speed setting that includes a decimal—such as 4.8 Km/H—press two numbered buttons in succession. For example, to select a speed setting of 4.8 Km/H, press the 4 button and then immediately press the 8 button.

To stop the walking belt, press the Stop button. The time will begin to flash in the display. To restart the walking belt, press the Start button or the Speed increase button.

4. Change the incline of the treadmill as desired.

To change the incline of the treadmill, press the Incline increase or decrease button or one of the numbered Quick Incline buttons. Each time you press one of the buttons, the treadmill will gradually adjust to the selected incline setting.

5. Follow your progress with the displays.

The matrix—When you select the manual mode, the matrix will display a track that represents 400 meters

(1/4 mile). As you exercise, the indicators around the track will appear in succession until the entire track appears. The track will then disappear and the indicators will again begin to appear in succession.



The Calories/Incline display—This display will show the approximate number of calories you have burned.

The display will also show the incline of the treadmill for a few seconds each time the incline of the treadmill changes.

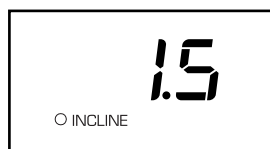

The Time display—

This display will show the elapsed time. Note: When an onboard workout is selected, the display will show the time remaining in the workout instead of the elapsed time.

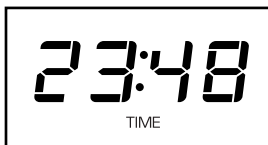

The Distance

display—This display will show the distance that you have walked or run.



The Speed/Pulse

display—This display will show the speed of the walking belt. The display will also show your heart rate when you use the heart rate monitor (see step 6 on page 20).

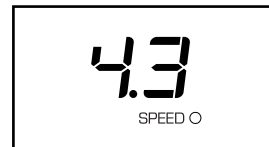

The Center display—This display will show workout instructions.

Press the Home button to return to the start mode (see THE INFORMATION MODE on page 23 to set the start mode). If necessary, press the Home button again.

When an iFit Live module is connected to www.iFit.com, the iFit Live symbol near the top of the display will light.



When a PROFORM SYNC is connected to the console, the Nike+iPod symbol near the top of the display will light.



To reset the displays, press the Stop button, remove the key, and then reinsert the key.

6. Measure your heart rate if desired.

Note: If you use the handgrip heart rate monitor and the chest heart rate monitor at the same time, the console will not display your heart rate accurately. For information about the chest heart rate monitor, see page 15.

Before using the handgrip heart rate monitor, remove the sheets of plastic from the metal contacts. In addition, make sure that your hands are clean.

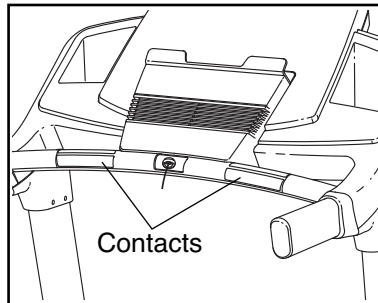

To measure your heart rate, **stand on the foot rails** and hold the metal contacts with your palms; **avoid moving your hands.** When your pulse is detected, several dashes will appear and then your heart rate will be shown. **For the most accurate heart rate reading, continue to hold the contacts for about 15 seconds.**

7. Turn on the fan if desired.

The fan features several speed settings. Press the Fan increase or decrease button to select a fan speed or to turn off the fan. Note: If the fan is on when the walking belt is stopped, the fan will turn off automatically after a few minutes.

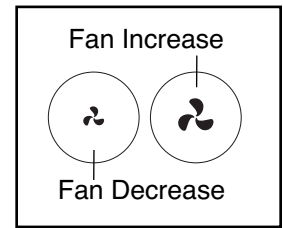

8. When you are finished exercising, remove the key from the console.

Step onto the foot rails, press the Stop button, and **adjust the incline of the treadmill to the lowest setting. The incline must be at the lowest setting or you may damage the treadmill when you fold it to the storage position.** Next, remove the key from the console and put it in a secure place.

When you are finished using the treadmill, press the power switch into the off position and unplug the power cord. **IMPORTANT: If you do not do this, the treadmill's electrical components may wear prematurely.**

HOW TO USE AN ONBOARD WORKOUT

1. Insert the key into the console.

See HOW TO TURN ON THE POWER on page 18.

2. Select an onboard workout.

To select an onboard workout, press the Calorie button, the Interval button, the Speed button, or the Endure button repeatedly until the desired workout appears in the display.

When you select an onboard workout, the displays will show the maximum incline, the duration, the distance, the maximum speed, and the name of the workout. In addition, a profile of the speed settings of the workout will appear in the matrix. If you select a calorie workout, the approximate number of calories you will burn will appear in the name of the workout.

3. Start the workout.

Press the Start button or the Speed increase button to start the workout. A moment after you press the button, the treadmill will automatically adjust to the first speed and incline settings of the workout. Hold the handrails and begin walking.

Each workout is divided into segments. One speed setting and one incline setting are programmed for each segment. Note: The same speed setting and/or incline setting may be programmed for consecutive segments.

During the workout, the profile will show your progress. The flashing segment of the profile represents the current segment of the work-

out. The height of the flashing segment indicates the speed setting for the current segment. At the end of each segment, a series of tones will sound and the next segment of the profile will begin to flash. If a new speed and/or incline setting is programmed for the next segment, the new speed and/or incline setting will appear in the displays for a few seconds and the treadmill will automatically adjust to the new speed and/or incline setting.

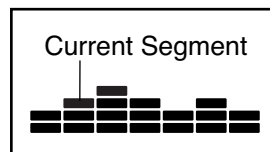

The workout will continue in this way until the last segment of the profile flashes in the display and the last segment ends. The walking belt will then slow to a stop.

Note: The calorie goal is an estimate of the number of calories that you will burn during the workout. The actual number of calories that you burn will depend on your weight. In addition, if you manually change the speed or incline of the treadmill during the workout, the number of calories you burn will be affected.

If the speed or incline setting is too high or too low at any time during the workout, you can manually override the setting by pressing the Speed or Incline buttons; **however, when the next segment of the workout begins, the treadmill will automatically adjust to the speed and incline settings for the next segment.**

To stop the workout at any time, press the Stop button. The time will begin to flash in the display. To resume the workout, press the Start button or the Speed increase button. The walking belt will begin to move at 2 Km/H. When the next segment of the workout begins, the treadmill will automatically adjust to the speed and incline settings for the next segment.

4. Follow your progress with the displays.

See step 5 on page 19.

5. Measure your heart rate if desired.

See step 6 on page 20.

6. Turn on the fan if desired.

See step 7 on page 20.

7. When you are finished exercising, remove the key from the console.

See step 8 on page 20.

HOW TO USE AN iFIT LIVE WORKOUT

Note: To use an iFit Live workout, you must have an optional iFit Live module. **To purchase an iFit Live module at any time, go to www.iFit.com or call the telephone number on the front cover of this manual.** You must also have access to a computer with a USB port and an internet connection. In addition, you must have access to a wireless network including an 802.11b router with SSID broadcast enabled (hidden networks are not supported). An iFit.com membership is also required.

1. Insert the key into the console.

See HOW TO TURN ON THE POWER on page 18.

2. Insert the iFit Live module into the console.

To insert the iFit Live module, see the instructions included with the iFit Live module.

3. Select a user.

If more than one user is registered, you can switch users in the iFit Live main screen. Press the increase and decrease buttons next to the Enter button to select a user.

4. Select an iFit Live workout.

To select an iFit Live workout, press one of the iFit Live buttons. Before some workouts will download, you must add them to your schedule on www.iFit.com.

Press the iFit Live button to download the next workout in your schedule. Press the My Trainer button, the My Maps button, the World Tour button, or the Event Training button to download the next workout of that type in your schedule. Press the Compete button to compete in a race that you have previously scheduled. **For more information about the iFit Live workouts, please see www.iFit.com.** Note: If there are no workouts of the selected type in your schedule, the next workout in your schedule will be downloaded.

When you select an iFit Live workout, the display will show the duration of the workout, the distance you will walk or run, the approximate number of calories you will burn, and the name of the workout. If you select a competition workout, the display will count down to the beginning of the race.

5. Start the workout.

See step 3 on page 21.

During some workouts, the voice of an audio coach will guide you through your workout. You can select a setting for your audio coach (see THE INFORMATION MODE on page 23).

To stop the workout at any time, press the Stop button. The time will begin to flash in the display. To resume the workout, press the Start button or the Speed increase button. The walking belt will begin to move at the speed setting for the first segment of the workout. When the next segment of the workout begins, the treadmill will automatically adjust to the speed and incline settings for the next segment.

6. Follow your progress with the displays.

See step 5 on page 19.

7. Measure your heart rate if desired.

See step 6 on page 20.

8. Turn on the fan if desired.

See step 7 on page 20.

9. When you are finished exercising, remove the key from the console.

See step 8 on page 20.

For more information about the iFit Live mode, go to www.iFit.com.

THE INFORMATION MODE

The console features an information mode that keeps track of treadmill information and allows you to personalize console settings.

To select the information mode, hold down the Stop button while inserting the key into the console, and then release the Stop button. When the information mode is selected, the following information will be shown:

The Time display will show the total number of hours the treadmill has been used.



The Distance display will show the total number of miles or kilometers that the walking belt has moved.



While the information mode is selected, press the decrease button next to the Enter button to select each of the following screens in the center display:

1. **UNITS:** To change the unit of measurement, press the Enter button. To view distance in miles, select ENGLISH. To view distance in kilometers, select METRIC.



2. **DEMO MODE:** The console features a display demo mode, designed to be used if the treadmill is displayed in a store. While the demo mode is turned on, the console will function normally when you plug in the power cord, press the power switch into the reset position, and insert the key into the console. However, when you remove the key, the displays will remain lit, although the buttons will not

function. If the demo mode is turned on, the word ON will appear in the center display. To turn on or turn off the demo mode, press the Enter button or the Speed decrease button.

3. **CONTRAST LVL:** Press the Incline increase and decrease buttons to adjust the contrast level of the displays. Then, press the Enter button.

If a module is connected, you may also select the following screens:

4. **MODULE:** If an iFit Live module is connected, the display will show the word WIFI. If a USB module is connected, the display will show the word USB/SD. If a SYNC is connected, the display will show the word NIKE+.
5. **AUDIO COACH:** To turn on or turn off the audio coach, press the Enter button.

If an iFit Live module is connected, you may also select the following screens:

5. **START MODE:** The start mode will appear when you insert the key into the console or when you press the Home button. Press the Enter button repeatedly to select the manual mode or the iFit Live mode as the start mode.
6. **CHECK WIFI:** Press the Enter button. The center display will show the software version number, the network SSID, the network encryption type, the wireless signal strength, the IP address of the module, the number of registered users and their names, and the results of the DNS lookup.
7. **SEND/OBTAIN DATA:** To send and receive workouts, workout logs, and updates, press the Enter button. When the process is finished, the words TRANSFERS DONE will appear in the display.

To exit the information mode, remove the key from the console.

HOW TO USE THE STEREO SOUND SYSTEM

This treadmill has been designed specifically to work with iPod and has been certified by the developer to meet Apple performance standards. To play music or audio books through the console's stereo speakers, you must connect your iPod, MP3 player, CD player, or other personal audio player to the console through the audio jack or through the optional PROFORM SYNC. The SYNC will charge your iPod while you use it.

To use the MP3 jack, locate the included audio wire and plug it into the MP3 jack on the top of the console. Then plug the audio wire into a jack on your MP3 player, CD player, or other personal audio player.

Make sure that the audio wire is fully plugged in.

To use the SYNC, plug a compatible iPod (not included) into the cable extending from the SYNC. **Make sure that the iPod is fully plugged in.**

Next, press the Play button on your iPod, MP3 player, CD player, or other personal audio player. Adjust the volume on your personal audio player or press the Volume increase and decrease buttons on the console.

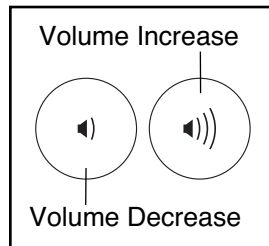

If you are using a personal CD player and the CD skips, set the CD player on the floor or another flat surface and not on the console.

HOW TO USE A PROFORM SYNC

The optional PROFORM SYNC enables you to record your treadmill workout results on your iPod® (not included). You can then upload your results to Nikeplus.com, where you can use an array of tools to analyze your results and monitor your progress toward your fitness goals. **To purchase a SYNC at any time, call the telephone number on the front cover of this manual.**

To use the SYNC, you must have an iPod nano® (4th or 5th generation) or an iPod touch® (2nd, 3rd, or 4th generation). You must also have access to a computer with an internet connection.

For more information about the SYNC, see the instructions included with the SYNC.

HOW TO FOLD AND MOVE THE TREADMILL

HOW TO FOLD THE TREADMILL

To avoid damaging the treadmill, adjust the incline to the lowest position before you fold the treadmill. Then, remove the key and unplug the power cord. **CAUTION:** You must be able to safely lift 45 lbs. (20 kg) to raise, lower, or move the treadmill.

1. Hold the metal frame firmly in the location shown by the arrow below. **CAUTION:** Do not hold the frame by the plastic foot rails. Bend your legs and keep your back straight.

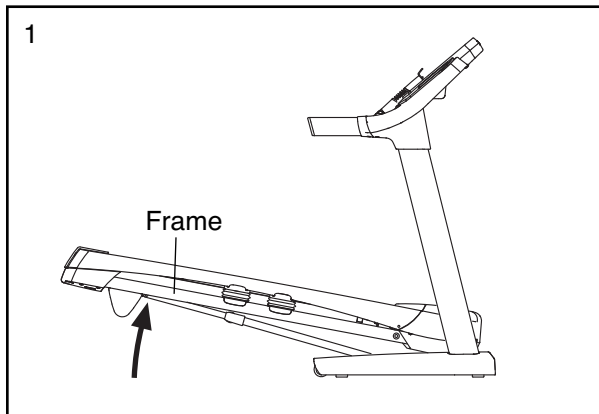

2. Raise the frame until the latch knob locks in the storage position. **CAUTION:** Make sure that the latch knob locks.

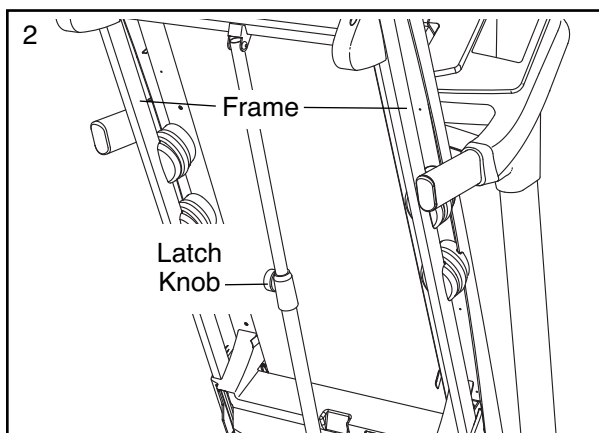

To protect the floor or carpet, place a mat under the treadmill. Keep the treadmill out of direct sunlight. Do not leave the treadmill in the storage position in temperatures above 85° F (30° C).

HOW TO MOVE THE TREADMILL

Before moving the treadmill, fold it as described at the left. **CAUTION:** Make sure that the latch knob is locked in the storage position. Moving the treadmill may require two people.

1. Hold the frame and one of the handrails, and place one foot against a wheel.

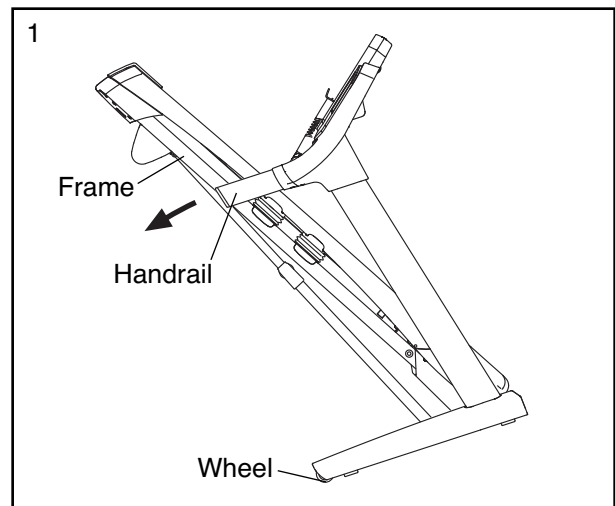

2. Pull back on the handrail until the treadmill will roll on the wheels, and carefully move it to the desired location. **CAUTION:** Do not move the treadmill without tipping it back, do not pull on the frame, and do not move the treadmill over an uneven surface.
3. Place one foot against a wheel, and carefully lower the treadmill.

HOW TO LOWER THE TREADMILL FOR USE

1. **See drawing 2.** Hold the upper end of the treadmill frame with your right hand. Then, pull the latch knob to the left. **IMPORTANT:** Do not turn the latch knob. If necessary, push the frame forward slightly. Pivot the frame downward a few inches, and release the latch knob.
2. **See drawing 1 at the left.** Hold the metal frame firmly with both hands, and lower it to the floor. **CAUTION:** Do not hold the frame by the plastic foot rails, and do not drop the frame. Bend your legs and keep your back straight.

TROUBLESHOOTING

Most treadmill problems can be solved by following the simple steps below. Find the symptom that applies, and follow the steps listed. If further assistance is needed, see the front cover of this manual.

SYMPTOM: The power does not turn on

- Make sure that the power cord is plugged into a properly earthed outlet (see page 16). If an extension cord is needed, use only a 3-conductor, 14-gauge (1 mm²) cord that is no longer than 5 ft. (1.5 m).
- After the power cord has been plugged in, make sure that the key is inserted into the console.
- Check the power switch located on the treadmill frame near the power cord. If the switch protrudes as shown, the switch has tripped. To reset the power switch, wait for five minutes and then press the switch back in.

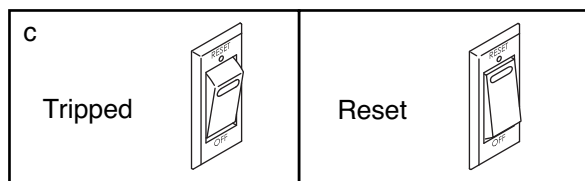

SYMPTOM: The power turns off during use

- Check the power switch (see the drawing above). If the switch has tripped, wait for five minutes and then press the switch back in.
- Make sure that the power cord is plugged in. If the power cord is plugged in, unplug it, wait for five minutes, and then plug it back in.

- Remove the key from the console, and then reinsert it.
- If the treadmill still will not run, please see the front cover of this manual.

SYMPTOM: The console displays remain lit when you remove the key from the console

- The console features a display demo mode, designed to be used if the treadmill is displayed in a store. If the displays remain lit when you remove the key, the demo mode is turned on. To turn off the demo mode, hold down the Stop button for a few seconds. If the displays are still lit, see THE INFORMATION MODE on page 23 to turn off the demo mode.

SYMPTOM: The displays of the console do not function properly

- Remove the key from the console and **UNPLUG THE POWER CORD**. Remove the three #8 x 1/2" Screws (1) and the two #8 x 3/4" Screws (2). Carefully pivot the Motor Hood (65) off.

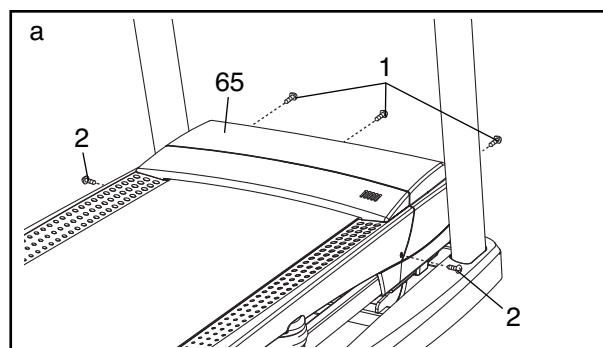

Locate the Reed Switch (52) and the Magnet (50) on the left side of the Pulley (49). Turn the Pulley until the Magnet is aligned with the Reed Switch. **Make sure that the gap between the Magnet and the Reed Switch is about 1/8 in. (3 mm).** If necessary, loosen the #8 x 3/4" Tek Screw (14), move the Reed Switch slightly, and then retighten the Screw. Reattach the Motor Hood (not shown) and run the treadmill for a few minutes to check for a correct speed reading.

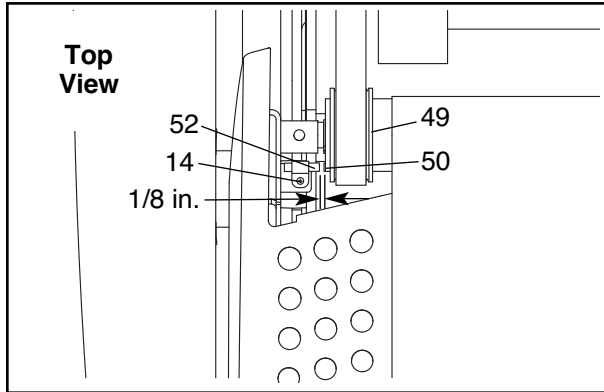

SYMPTOM: The incline of the treadmill does not change correctly

- a. With the key in the console, press one of the Incline buttons. **While the incline is changing, remove the key.** After a few seconds, reinsert the key. The treadmill will automatically rise to the maximum incline level and then return to the minimum level. This will recalibrate the incline system.

SYMPTOM: The walking belt slows when walked on

- a. If an extension cord is needed, use only a 3-conductor, 14-gauge (1 mm²) cord that is no longer than 5 ft. (1.5 m).

- b. If the walking belt is overtightened, treadmill performance may decrease and the walking belt may become damaged. Remove the key and **UNPLUG THE POWER CORD.** Using the hex key, turn both idler roller screws counterclockwise, 1/4 of a turn. When the walking belt is properly tightened, you should be able to lift each edge of the walking belt 2 to 3 in. (5 to 7 cm) off the walking platform. Be careful to keep the walking belt centered. Then, plug in the power cord, insert the key, and run the treadmill for a few minutes. Repeat until the walking belt is properly tightened.

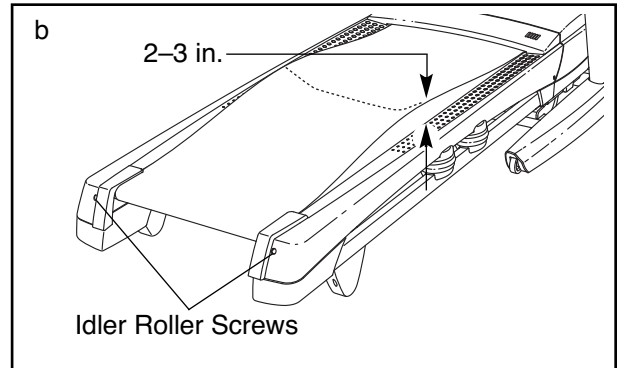

- c. Your treadmill features a walking belt coated with high-performance lubricant. **IMPORTANT: Never apply silicone spray or other substances to the walking belt or the walking platform unless instructed to do so by an authorized service representative. Such substances may deteriorate the walking belt and cause excessive wear.** If you suspect the walking belt needs more lubricant, see the front cover of this manual.
- d. If the walking belt still slows when walked on, see the front cover of this manual.

SYMPTOM: The walking belt is off-center or slips when walked on

- a. **If the walking belt is off-center**, first remove the key and **UNPLUG THE POWER CORD**. **If the walking belt has shifted to the left**, use the hex key to turn the left idler roller screw clockwise 1/2 of a turn; **if the walking belt has shifted to the right**, turn the left idler roller screw counterclockwise 1/2 of a turn. Be careful not to overtighten the walking belt. Then, plug in the power cord, insert the key, and run the treadmill for a few minutes. Repeat until the walking belt is centered.

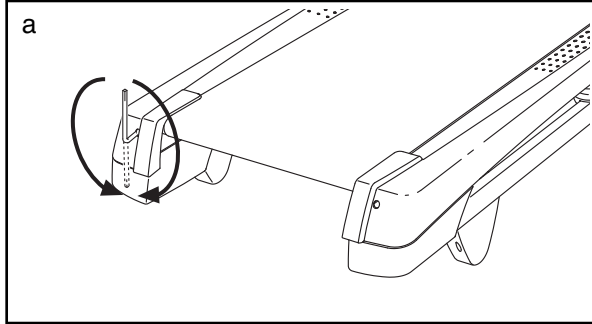

- b. **If the walking belt slips when walked on**, first remove the key and **UNPLUG THE POWER CORD**. Using the hex key, turn both idler roller screws clockwise, 1/4 of a turn. When the walking belt is correctly tightened, you should be able to lift each edge of the walking belt 2 to 3 in. (5 to 7 cm) off the walking platform. Be careful to keep the walking belt centered. Then, plug in the power cord, insert the key, and carefully walk on the treadmill for a few minutes. Repeat until the walking belt is properly tightened.

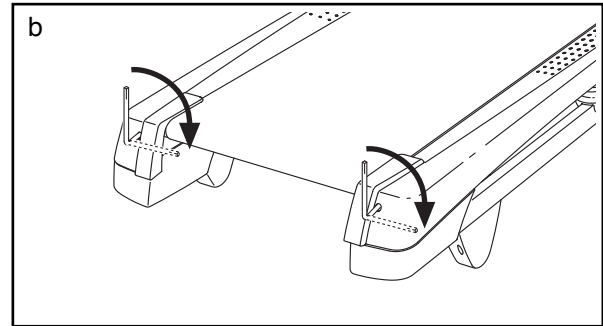

EXERCISE GUIDELINES

⚠ WARNING: Before beginning this or any exercise program, consult your physician. This is especially important for persons over age 35 or persons with pre-existing health problems.

The heart rate monitor is not a medical device. Various factors may affect the accuracy of heart rate readings. The heart rate monitor is intended only as an exercise aid in determining heart rate trends in general.

These guidelines will help you to plan your exercise program. For detailed exercise information, obtain a reputable book or consult your physician. Remember, proper nutrition and adequate rest are essential for successful results.

EXERCISE INTENSITY

Whether your goal is to burn fat or to strengthen your cardiovascular system, exercising at the proper intensity is the key to achieving results. You can use your heart rate as a guide to find the proper intensity level. The chart below shows recommended heart rates for fat burning and aerobic exercise.

165	155	145	140	130	125	115	♥
145	138	130	125	118	110	103	♥
125	120	115	110	105	95	90	♥
<hr/>							
20	30	40	50	60	70	80	

To find the proper intensity level, find your age at the bottom of the chart (ages are rounded off to the nearest ten years). The three numbers listed above your age define your “training zone.” The lowest number is the heart rate for fat burning, the middle number is the heart rate for maximum fat burning, and the highest number is the heart rate for aerobic exercise.

Burning Fat—To burn fat effectively, you must exercise at a low intensity level for a sustained period of time. During the first few minutes of exercise, your body uses *carbohydrate calories* for energy. Only after the first few minutes of exercise does your body begin to use stored *fat calories* for energy. If your goal is to burn fat, adjust the intensity of your exercise until your heart rate is near the lowest number in your training zone. For maximum fat burning, exercise with your heart rate near the middle number in your training zone.

Aerobic Exercise—If your goal is to strengthen your cardiovascular system, you must perform aerobic exercise, which is activity that requires large amounts of oxygen for prolonged periods of time. For aerobic exercise, adjust the intensity of your exercise until your heart rate is near the highest number in your training zone.

WORKOUT GUIDELINES

Warming Up—Start with 5 to 10 minutes of stretching and light exercise. A warm-up increases your body temperature, heart rate, and circulation in preparation for exercise.

Training Zone Exercise—Exercise for 20 to 30 minutes with your heart rate in your training zone. (During the first few weeks of your exercise program, do not keep your heart rate in your training zone for longer than 20 minutes.) Breathe regularly and deeply as you exercise—never hold your breath.

Cooling Down—Finish with 5 to 10 minutes of stretching. Stretching increases the flexibility of your muscles and helps to prevent post-exercise problems.

EXERCISE FREQUENCY

To maintain or improve your condition, complete three workouts each week, with at least one day of rest between workouts. After a few months of regular exercise, you may complete up to five workouts each week, if desired. Remember, the key to success is to make exercise a regular and enjoyable part of your everyday life.

PART LIST

Model No. PETL12711.0 R0511A

Key No.	Qty.	Description	Key No.	Qty.	Description
1	23	#8 x 1/2" Screw	51	1	Reed Switch Clip
2	57	#8 x 3/4" Screw	52	1	Reed Switch
3	1	3/8" x 2" Bolt	53	1	Storage Latch
4	6	5/16" x 1 1/4" Screw	54	1	Drive Motor
5	4	5/16" x 1" Screw	55	1	Motor Belt
6	1	3/8" x 1 3/4" Bolt	56	1	Frame
7	4	3/8" x 2 3/4" Screw	57	2	Rear Foot
8	4	3/8" x 1 1/4" Screw	58	1	Right Rear Cover
9	2	#10 x 3/4" Screw	59	4	Rubber Cushion
10	13	#8 x 1/2" Ground Screw	60	1	Right Foot Rail
11	8	5/16" Star Washer	61	1	Idler Roller
12	2	3/8" Nut	62	1	Left Rear Cover
13	4	3/8" Star Washer	63	1	Hex Key
14	17	#8 x 3/4" Tek Screw	64	1	5/32" Hex Key
15	2	Idler Roller Screw	65	1	Motor Hood
16	1	3/8" x 1 1/2" Bolt	66	1	Hood Accent
17	2	3/8" x 1 3/4" Wheel Bolt	67	2	Incline Frame Spacer
18	2	#8 x 1 3/4" Screw	68	1	Incline Stop Bracket
19	9	#8 x 7/16" Screw	69	1	Incline Motor
20	2	5/16" Motor Screw	70	1	Incline Frame
21	2	1/2" x 2 1/4" Bolt	71	2	Frame Spacer
22	2	3/8" x 1" Bolt	72	1	Controller
23	4	5/16" x 1 3/4" Shoulder Bolt	73	1	Controller Plate
24	1	1/4" x 1" Screw	74	2	Hood Post
25	4	#8 x 1" Screw	75	1	Power Switch
26	1	#8 x 3/4" Machine Bolt	76	1	Power Cord
27	1	#8 Nut	77	1	Grommet
28	4	#8 x 3/4" Belly Pan Screw	78	1	Belly Pan
29	1	3/8" x 2" Hex Head Bolt	79	1	Left Upright Cover
30	4	5/16" Flat Washer	80	1	Right Upright Cover
31	2	5/16" Cage Nut	81	1	Upright Wire
32	2	1/2" Nut	82	1	Left Base Cover
33	6	3/8" Jam Nut	83	1	Right Base Cover
34	4	5/16" Nut	84	2	Handrail Cap
35	3	1/4" Star Washer	85	1	Left Handrail Cover
36	2	1/4" Flat Washer	86	1	Right Handrail Cover
37	1	Left Front Isolator Top	87	1	Right Handrail
38	2	Rear Isolator Top	88	1	Left Handrail
39	4	Isolator	89	1	Left Upright
40	4	Isolator Bottom	90	1	Right Upright
41	1	Right Front Isolator Top	91	2	Warning Decal
42	1	Left Foot Rail	92	4	Base Pad
43	1	Caution Decal	93	1	Crossbar
44	1	Walking Platform	94	1	Base
45	1	Walking Belt	95	1	Right Wheel Cap
46	2	Belt Guide	96	1	Left Wheel Cap
47	2	Foot Rail Track	97	2	Wheel
48	4	Cable Tie	98	1	Key/Clip
49	1	Drive Roller/Pulley	99	1	Cable Tie
50	1	Magnet	100	1	Audio Wire

Key No.	Qty.	Description	Key No.	Qty.	Description
101	1	Module Housing	113	4	5/16" Flat Washer
102	1	Console Back	114	1	UK Power Cord
103	1	Console	115	1	Receptacle
104	1	Console Frame	116	2	Motor Bushing
105	2	Ground Wire	117	1	Filter Bracket
106	2	Console Clamp	118	1	Filter
107	1	Left Tray	119	1	Motor Isolator
108	1	Right Tray	120	1	Chest Strap
109	1	Console Base	121	1	Sensor
110	1	Base Ground Wire	122	1	Grounding Bracket
111	3	Hood Clip	*	-	User's Manual
112	2	#10 x 3/4" Flat Head Screw			

Note: Specifications are subject to change without notice. For information about ordering replacement parts, see the back cover of this manual. *These parts are not illustrated.

EXPLODED DRAWING A

Model No. PETL12711.0 R0511A

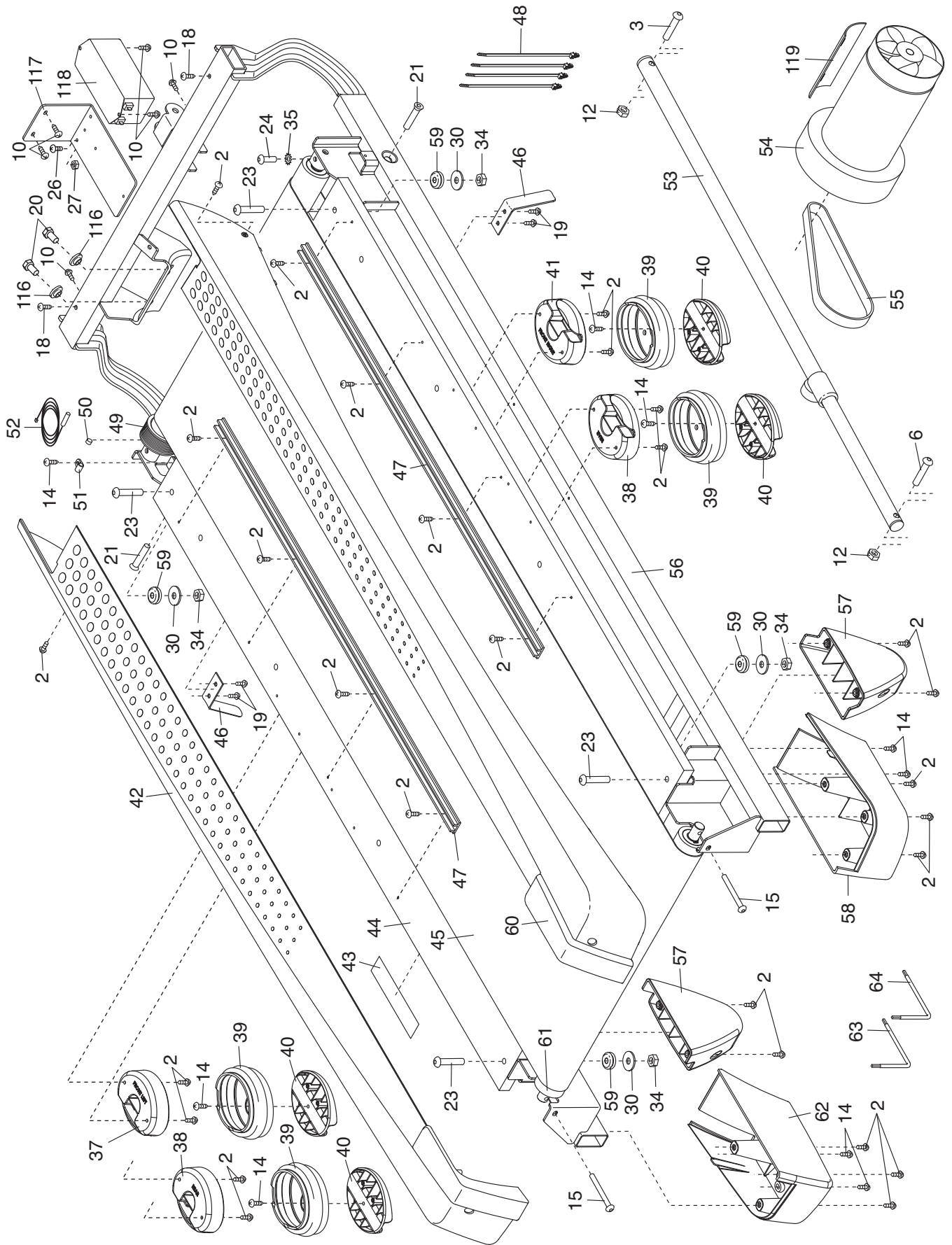

EXPLODED DRAWING B

Model No. PETL12711.0 R0511A

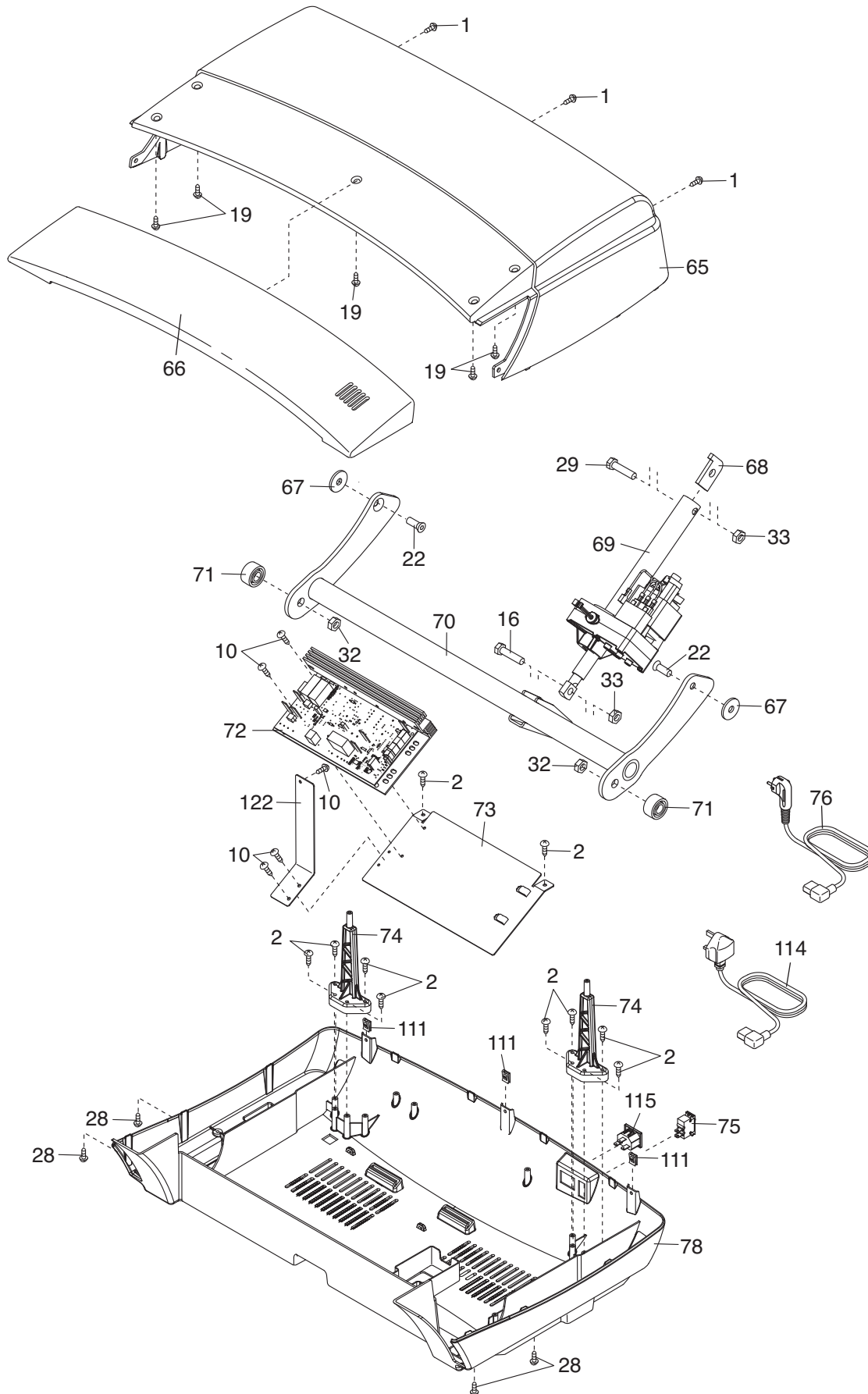

EXPLODED DRAWING C

Model No. PETL12711.0 R0511A

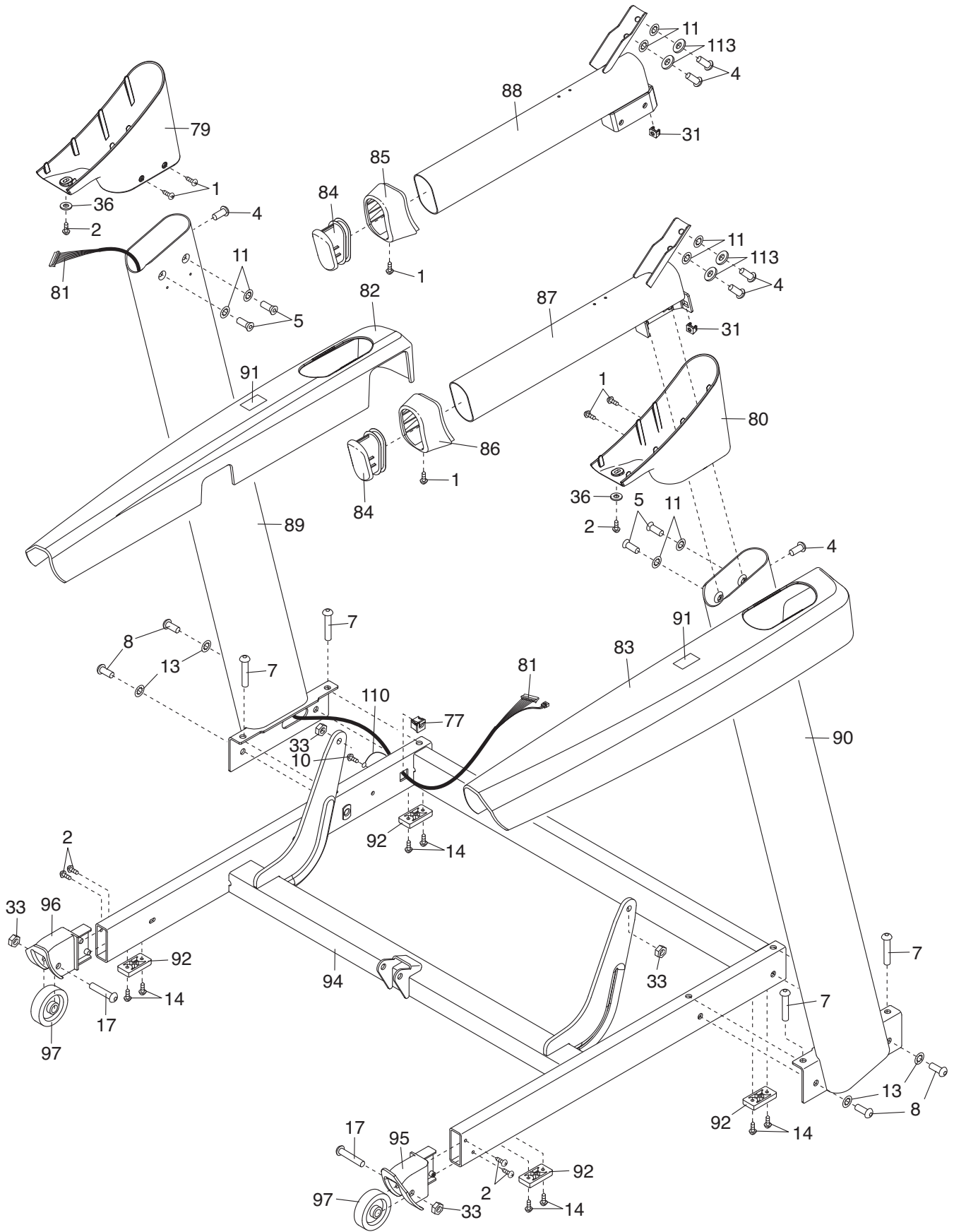

EXPLODED DRAWING D

Model No. PETL12711.0 R0511A

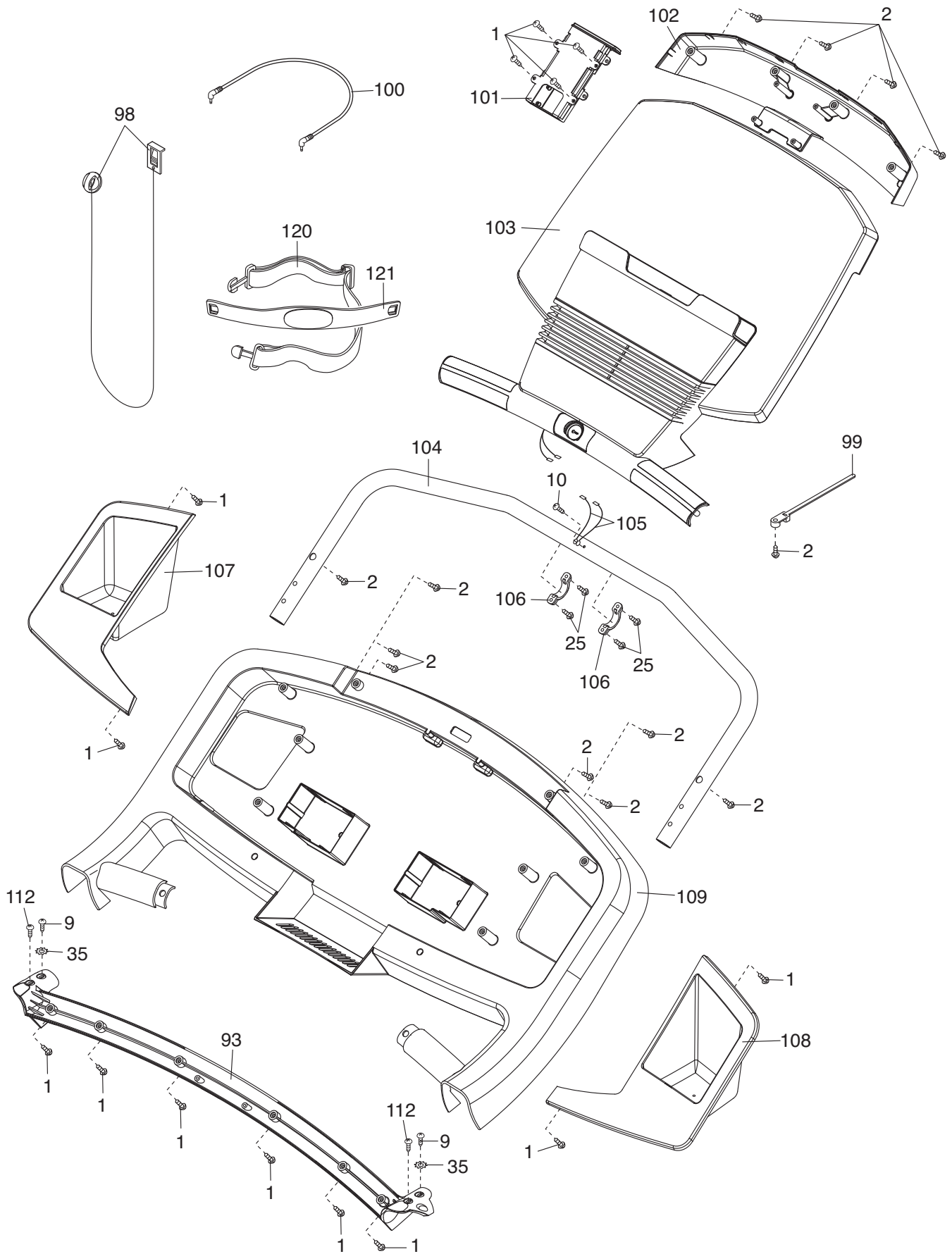

ORDERING REPLACEMENT PARTS

To order replacement parts, please see the front cover of this manual. To help us assist you, be prepared to provide the following information when contacting us:

- the model number and serial number of the product (see the front cover of this manual)
- the name of the product (see the front cover of this manual)
- the key number and description of the replacement part(s) (see the PART LIST and the EXPLODED DRAWING near the end of this manual)

RECYCLING INFORMATION

This electronic product must not be disposed of in municipal waste. To preserve the environment, this product must be recycled after its useful life as required by law.

Please use recycling facilities that are authorized to collect this type of waste in your area. In doing so, you will help to conserve natural resources and improve European standards of environmental protection. If you require more information about safe and correct disposal methods, please contact your local city office or the establishment where you purchased this product.

