

SPECIFICATIONS

ASHLY

70 VOLT POWER AMPLIFIERS

Models P70-400, P70-800

TABLE OF CONTENTS

Introduction 1
 Standard Connections and Controls 2
 Typical Applications 5
 Input Options 7
 Transformer Input Option 7
 Limiter Input Option 7
 Crossover Input Option 8
 Mic/Line Mixer Input Option 8
 Design Theory 10
 Dimensional Diagrams 11
 Specifications 12

INTRODUCTION... Why MOSFETS?

The Ashly P70 series MOSFET amplifiers combine the sonic excellence of a high-end stereo amp with the ruggedness and stamina necessary in commercial audio. The P70 series amps use power MOSFETs (metal-oxide-semiconductor, field-effect transistors) for their superior audio fidelity and unmatched reliability as proven in Ashly amps for over ten years.

MOSFET output devices are used in the P70 series amps because of their superior performance characteristics over bipolar power transistors which are normally used in conventional power amp designs. The power MOSFET is inherently more self-regulating and does not exhibit the failure modes that bipolar transistors are susceptible to. MOSFETS do not require any thermal runaway compensation circuitry, thus making the design simpler and more reliable. MOSFETS do not exhibit secondary breakdown (an instantaneous failure in bipolar transistors when their collector current exceeds a safe level, even at voltages much lower than their maximum rating). The MOSFET will even withstand a dead shorted output resulting in very high drain current without any protection circuitry for a very short time.

	P70-400	P70-800
Output Power <i>EIA Spec.</i> (±1dB <1% THD @ 1KHz) Both Channels Driven		
Dual	200W @ 70V	400W @ 70V
Bridged-Mono	400W @ 140V	800W @ 140V
FTC Spec. (<.1%THD 20Hz-20KHz) Both Channels Driven		
Dual	160W @ 70V	320W @ 70V
Bridge-Mono	320W @ 140V	640W @ 140V
Total Harmonic Distortion (at rated power)		
20Hz-1KHz	<.05%	<.05%
20KHz	<.1%	<.1%
IM Distortion (at rated power)		
	<.05%	<.05%
Damping Factor (25Ω)	>500 20Hz-1KHz	>500 20Hz-1KHz
Bandwidth (-3dB)	100KHz	100KHz
Slew Rate	>20V/μS	>20V/μS
Frequency Response (20Hz-20KHz)	+0/- .4dB	+0/- .4dB
Full Power Input Sensitivity	1.77V	1.77V
Input Impedance	20KΩBalanced 20KΩBalanced	20KΩBalanced 20KΩBalanced
Hum and Noise (20Hz-20KHz unweighted)	>105dB below full output	>105dB below full output
Cooling	Forced Air	Forced Air
Power Requirement	790W Max, 75W Idle	1580W Max, 150W Idle
	120VAC 50-60Hz	120VAC 50-60Hz
	(240V available)	(240V available)
Size	19" W x 3.5" H x 17.8" D	19" W x 3.5" H x 17.8" D
Shipping Weight	44 lbs.	60 lbs.

DIMENSIONS

MOSFETS also do not have a “storage time” associated with them (a phenomenon found in bipolar transistors in which a certain amount of time is required to turn the transistor off). Therefore the MOSFET is said to be a “fast” device which can function very accurately with high amplitude/high frequency signals and transient waveforms.

The unmatched reliability of the power MOSFET output devices and the integrity of the rugged mechanical design of the P70 series amplifiers ensure years of maintenance-free service.

UNPACKING

As a part of our system of quality control, every Ashly product is carefully inspected before leaving the factory to ensure flawless appearance. After unpacking, please inspect for any physical damage. Save the shipping carton and all packing materials, as they were carefully designed to reduce to minimum the possibility of transportation damage should the unit again require packing and shipping. In the event that damage has occurred, immediately notify your dealer so that a written claim to cover the damages can be initiated.

The right to any claim against a public carrier can be forfeited if the carrier is not notified promptly and if the shipping carton and packing materials are not available for inspection by the carrier. Save all packing materials until the claim has been settled.

POWER

Connect the P70 series amplifier to a standard 3-wire grounded electrical outlet supplying 120 volts, 50-60 Hz (some export models are wired for 240 volts). The power consumption is given in the Specifications section.

STANDARD CONNECTIONS AND CONTROLS

The rear panel of a P70-800 amplifier with the standard input panel is shown in figure 1. For descriptions of other input options available, see the section on input options.

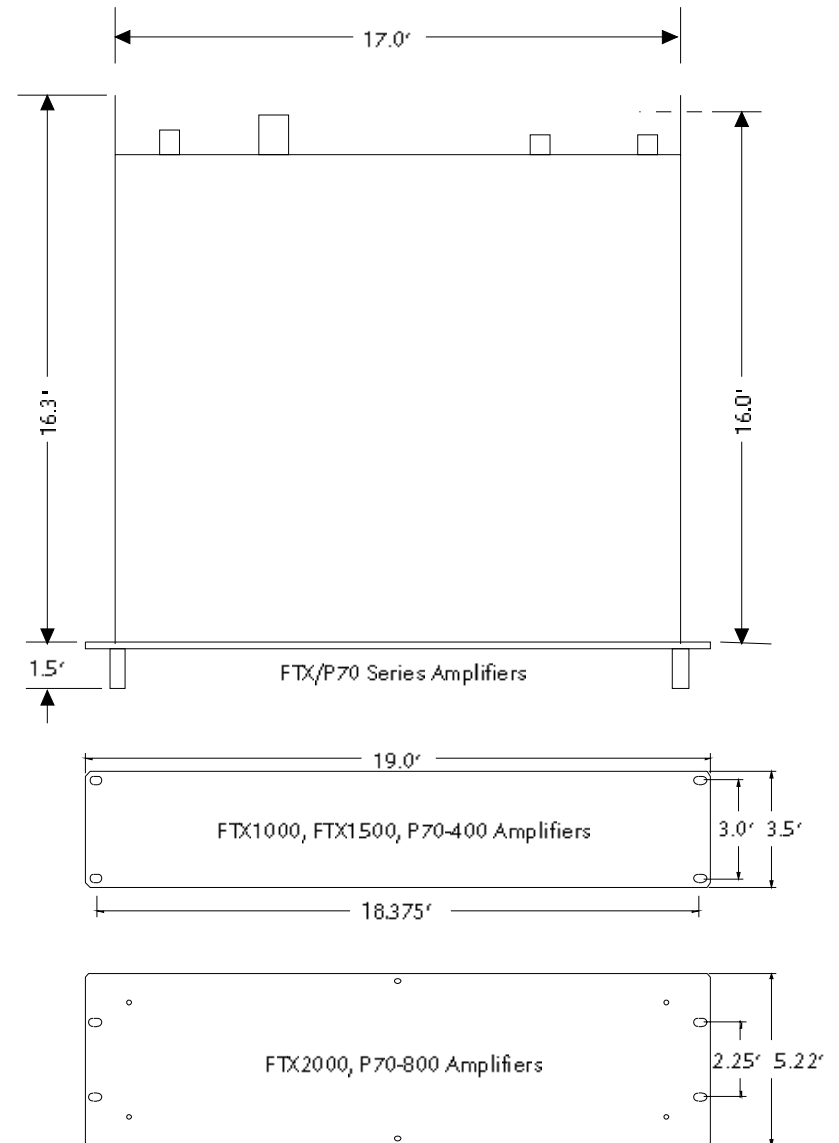

DESIGN THEORY

Ashly P70 series amplifiers use a direct-coupled output stage with totally discrete high-voltage, wide bandwidth electronics. A modulated power supply improves output device efficiency, allowing more power with less heat dissipation. The input section is a complimentary Darlington differential amplifier stage for high common-mode rejection, low noise and low distortion. All voltage gain stages in the amplifier operate class A for low distortion. The complimentary MOSFET output stage has almost infinite current gain, therefore the output driver stages are nearly lossless. All circuitry within the feedback loop is discrete which allows the amplifier to recover instantly and cleanly without any spikes or glitches from a clipped condition. This overall design approach inherently assures low noise, low distortion, and excellent transient and overload response. Inputs are bridging and active balanced, and all input connections can operate as balanced or unbalanced. Turn-on delay relays are not needed because of the symmetry of the totally discrete complementary electronics.

The P70 amplifiers incorporate output VI limiting to protect against excessive current at the speaker terminals. If current becomes too high, the amplifier instantaneously reduces output voltage to a safe level. This protects against low impedance loads, a short across the outputs, as well as DC. Additionally, an internal fuse follows the output signal of each channel. Under normal operating conditions however, the VI limiter handles any fault condition at the output. A blown fuse will only occur in the rare event of amplifier failure. All electronic components are mounted to rugged glass-epoxy circuit boards. Large computer-grade electrolytic capacitors assure long service.

The P70 series amplifiers are packaged in a rugged 16-gauge steel chassis. The power transformer is located at the front center of the chassis to minimize front panel torsion. Each channel's electronics and heat sink are identical yet completely independent and modular, each with a single plug-in connector for ease of servicing. Large custom black-anodized extruded aluminum heat sinks with fan cooling provide plenty of thermal headroom.

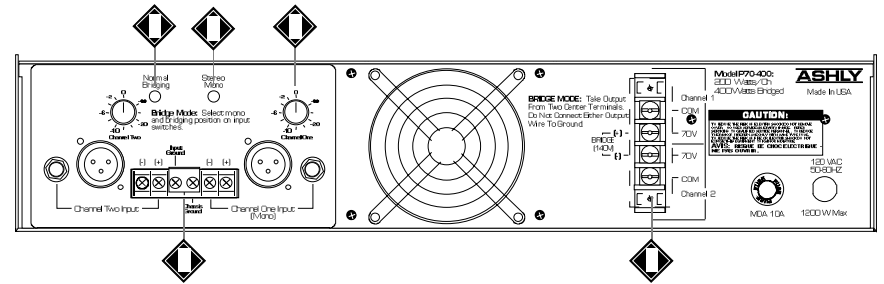

Figure 1: P70-400 Rear Panel With Standard Input

1. INPUTS

The **standard input** panel of the P70 series amps is equipped with balanced 1/4" tip-ring-sleeve (TRS) phone jacks, balanced XLR jacks, and balanced screw-terminal inputs. The three types of connectors are internally wired in parallel and may be used with balanced or unbalanced connections. The inputs are configured for pin 2 hot, meaning that a positive voltage applied to pin 2 will result in a positive output voltage across the speaker terminals. Pin 2 of the XLR jack is equivalent to the tip of the 1/4" TRS jack as shown in figure 1. An optional plug-in input transformer is available on all P70 amplifiers.

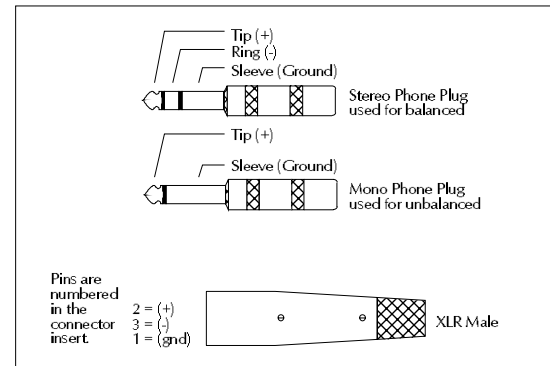

Figure 2: Input Connectors

It is recommended that balanced input connections be used when possible to reduce ground-loop and environment-induced hum and noise. If an **unbalanced input** connection is used, then the (-) connection (XLR pin 3) should be connected to input ground (XLR pin 1). If the 1/4" input jack is used unbalanced, the use of a mono (tip-sleeve) plug will automatically tie the (-) connection to input ground. The CHASSIS GROUND terminal is internally connected to the chassis, the AC earth ground, and the power amplifier's signal ground. The INPUT GROUND terminal is tied to the XLR pin 1 and the 1/4" jack sleeve.

It is recommended that the input and chassis ground terminals remain connected with the factory-supplied jumper strap.

In situations where the power amp and its signal source are separated by great distances, a ground voltage difference may exist between the amp's chassis ground and the input cable's ground. Connection of these two grounds through the jumper strap may cause large ground currents to flow (which is known as a ground loop), causing a hum noise in the amp's output. Unless you have such a situation with a hum problem that cannot be solved by using balanced input connections, the ground jumper strap should remain in place.

2. NORMAL/BRIDGING SWITCH

This switch selects between NORMAL mode (70 Volt) in the "out" position where both channels are in-phase, and BRIDGING mode (140 Volt) in the "in" position where channel 2 is switched out-of-phase. In bridging mode, the channel 1 output terminal is the (+) in-phase speaker output terminal and the channel 2 output terminal becomes the (-) out-of-phase speaker terminal. To make the switch non-accessible, its gray button is removable by simply pulling it straight off.

3. STEREO/MONO SWITCH

This switch selects between STEREO mode in the "out" position and MONO mode (where channel 1 input is routed to both channels of the amp) in the "in" position. In mono mode, an input signal needs only to be connected to channel 1. To make the switch non-accessible, its gray button is removable by simply pulling it straight off.

4. LEVEL CONTROLS

The level controls allow attenuation (calibrated in dB) of the input signal. In MONO mode, the CHANNEL ONE level control affects both output levels and CHANNEL TWO level control is unused. It is recommended that the level controls be operated at full level (0 dB attenuation) in most situations to maximize the headroom in the signal source.

5. SPEAKER OUTPUTS

A four terminal barrier strip provides the two channels of output. In BRIDGING mode (140 Volt), the channel 1 output terminal is the (+) in-phase speaker connection and the channel 2 output terminal becomes the (-) out-of-phase speaker connection. **CAUTION! NEVER CONNECT THE TWO OUTPUT TERMINALS TOGETHER OR CONNECT EITHER OUTPUT TERMINAL TO COMMON.** To prevent electric shock, always replace the barrier strip protective cover before applying power to the amplifier.

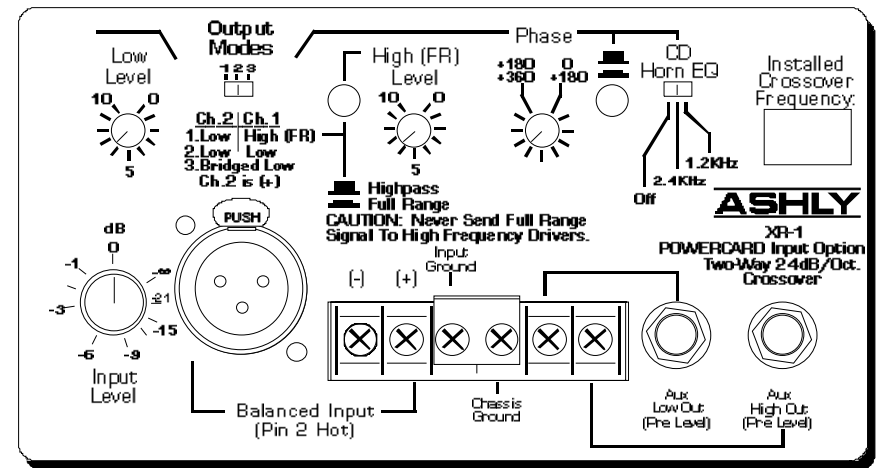

Figure 8: Crossover Input Option

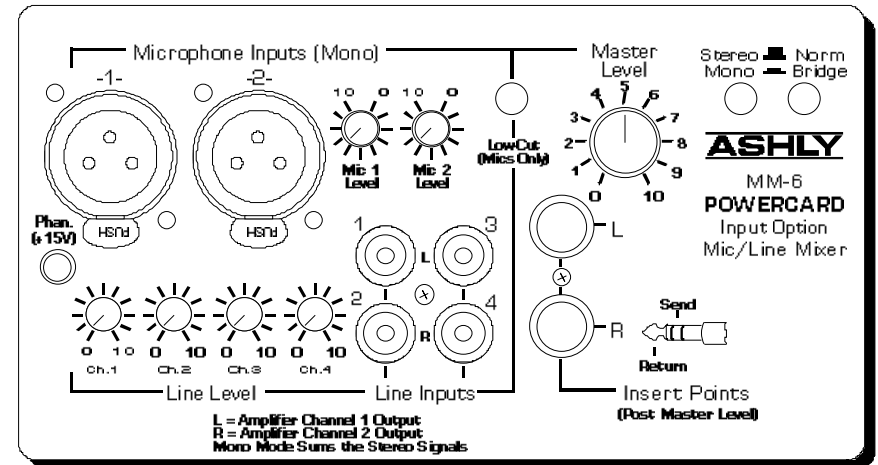

Figure 9: Mic/Line Mixer Input Option

CROSSOVER INPUT OPTION

The XR-1 crossover input option provides separate high-pass and low-pass 24 dB/octave filters allowing flexibility in biamped systems. Output mode switching allows the amplifier to be configured normal two-way, full range with low out, mono low out with aux high out, and bridged low out with aux high out. Included with the XR-1 are single in-line package (SIP) resistor networks which allow preselection of three standard crossover frequencies. A phase alignment control and switch are provided for acoustical alignment of high frequency drivers, and two types of CD horn EQ are available. A third-order 20Hz low-cut filter removes inaudible subsonic signals from the low frequency signal path.

MIC/LINE MIXER INPUT OPTION

The MM-6 mixer input option provides four high-impedance line inputs and two balanced low-impedance microphone inputs, each with its own level control. A switchable 200 Hz high-pass filter is provided on the mic inputs to reduce unwanted low frequency noise. An internal jumper allows selection of phantom power applied to the mic inputs for use with condenser mics. The MM-6 has a master level control and selectable stereo, mono and bridging modes. Insert Points are available for patching external processing into the left and right channels.

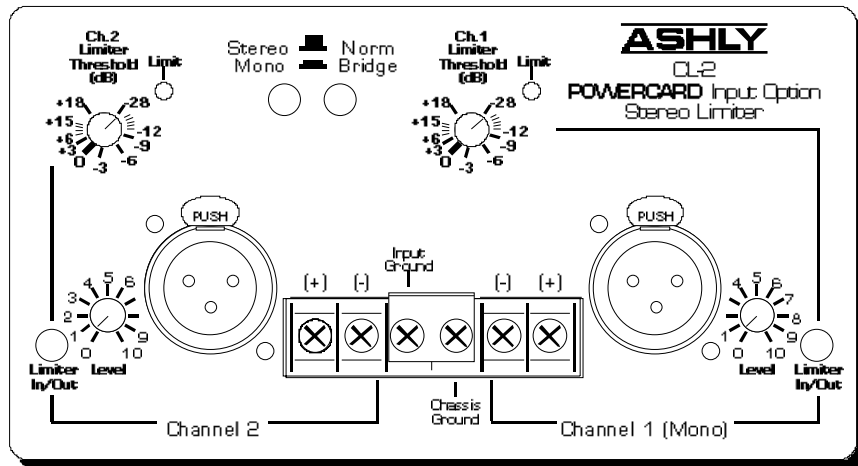

Figure 7: Limiter Input Option

METERS

The P70 amplifiers are equipped with front panel meter displays which respond to peak output voltage. An eleven-segment, three-color LED display covers a 27 dB range. The green LED's at the left end of the meter arrays indicate a normal thermal status. In the event that the amplifier overheats, these LED's will turn off but the power switch will remain illuminated, indicating the thermal protection status. When the heat sinks return to safe operating temperatures, the amp will turn itself back on and illuminate the left-most green LED's.

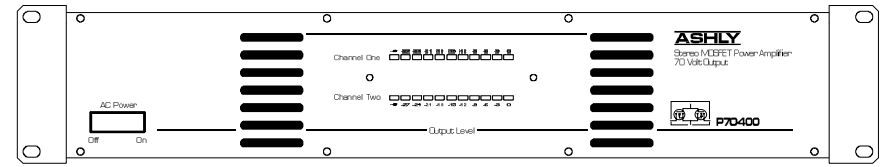

figure 3: P70-400 Front Panel

TYPICAL APPLICATIONS

DUAL CHANNEL OPERATION

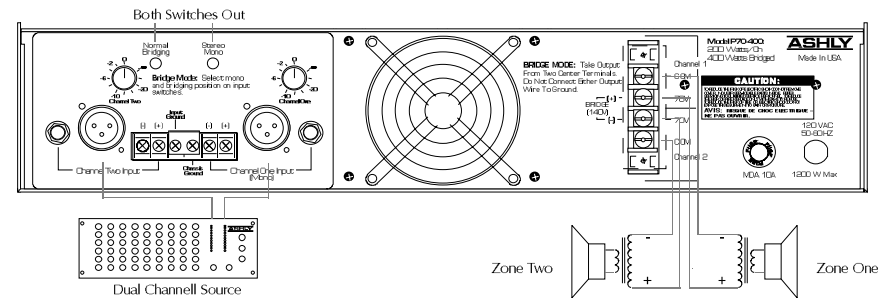

Figure 4: Operation in Two Channel Mode

MONO OPERATION

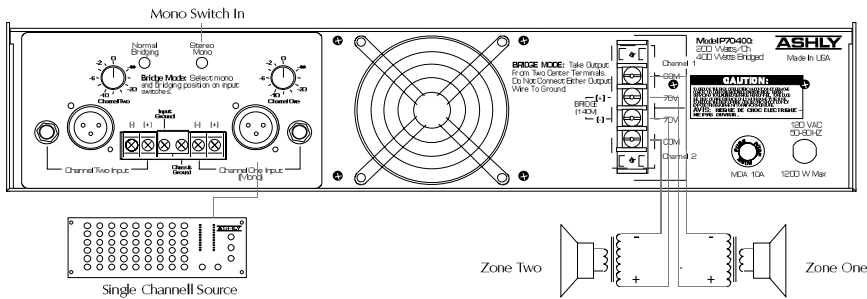

Figure 5: Operation in Normal Mono Mode

With the MONO switch depressed, the channel 1 input is routed to both amplifier channels. Both channels are then controlled by the channel 1 level control. Both outputs will be identical and can be connected to separate speaker lines. If you wish to drive both channels of the amp with one signal and yet maintain separate level control, simply run the amp in stereo mode and hardwire channel one input to channel two input on the terminal strip. **CAUTION! NEVER CONNECT THE OUTPUT TERMINALS TOGETHER!**

BRIDGING OPERATION (140 Volt)

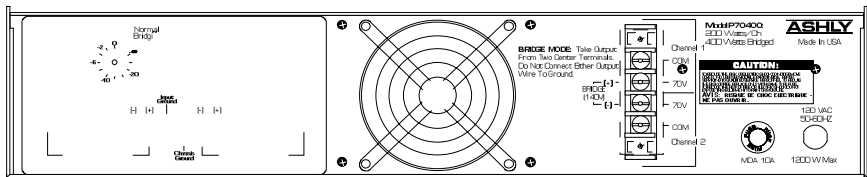

Figure 6: Operation in Bridging Mode

To operate in bridging mode, depress both the MONO switch and the BRIDGING switch. The MONO switch depressed routes the channel 1 input to both amplifier channels and the BRIDGING switch depressed inverts the phase of the input signal before it is fed to the channel 2 power amp section. The two amplifiers' outputs are therefore 180 degrees

out-of-phase. The channel 1 output terminal is used as the positive and the channel 2 output terminal becomes the negative. The COMMON terminals are not used. **CAUTION! NEVER GROUND EITHER OUTPUT TERMINAL.**

In bridging mode, the output voltage is doubled from 70V to 140V. **ONLY USE 140V STEP-DOWN TRANSFORMERS WHEN RUNNING IN BRIDGED MONO.** If you attempt to use a 70V transformer in this mode, you will have twice the rated current through the 70V transformer, creating a potential fire hazard. You will also saturate the core of the transformer, adding distortion to the signal. The amplifier will become loaded down below the desired point and run hotter than normal, increasing the likelihood of thermal shut-down.

INPUT OPTIONS

Input option panels are available to provide built-in features such as stereo limiting, mic and line inputs, crossover for bi-amplified systems, and input transformers for signal isolation. Ashly P70 series amplifiers as well as all other Ashly amps (excluding the single rack space SRA-120) will accept Ashly input options. A brief description of currently stocked input options follows. Consult your dealer for detailed information on the input options, or call the factory.

TRANSFORMER INPUT OPTION

The ITC-2 transformer input option may be installed in either or both amplifier channels. The input transformer provides complete electrical isolation from the amplifier and its signal source to eliminate any ground-induced hum noise, as well as further reducing any common-mode noise and radio frequency interference. The ITC-2 must be installed in the standard input panel and does not change the operation of any switches or controls.

LIMITER INPUT OPTION

The CL-2 limiter input option provides peak signal limiting from excessive input levels for speaker protection and overall level control. Separate recessed limiter threshold controls, limit indicator LED's and limit on/off switches are provided on each channel allowing fully discrete stereo limiting operation.