

A photograph of an industrial robotic welding cell. Several robotic arms with blue and orange cables are positioned over a metal workpiece. Bright sparks are being generated at the points where the welding torches meet the metal. The scene is lit with a warm, golden light from the welding process.

Rotary disconnect switches

Flexible
options for
every application

EATON

Powering Business Worldwide

Eaton's new line of rotary disconnects provides OEM customers with a flexible product offering that has industry-leading fault current ratings.

The product range encompasses both the UL® 98 and UL 508 standards, and is the latest in a series of new and innovative products from the switching device product line.

The R5 (Rotary 508) Series of switches are UL 508 listed devices that are suitable for use as motor disconnects. Ideal for panel builders and custom control cabinets, the R5 Series is excellent for isolation of circuits in panels, or as enclosed motor disconnects when located downstream from appropriate overcurrent protection.

This totally new line of products incorporates a truly modular design, allowing for simple addition of fourth poles, neutral modules, auxiliary contact modules and many other popular accessories.

Additionally, when protected by applicable upstream fusing, these products can be rated up to 65 kAIC—one of the highest short-circuit ratings in the industry. The R5 switches are available in two frame sizes—A-Frame (16–40A) and B-Frame (60–80A).

The R9 (Rotary 98) product offering consists of UL 98 listed fusible and non-fusible products that may be used as service entrance devices, or anywhere a local means of disconnect is needed or required. Both the fusible and non-fusible products span six frame sizes, or footprints, and have 100 kAIC or 200 kAIC ratings.

The R9 offering includes a modular grouping of non-fusible switches at the low end of the range (30–100A), providing a compact, flexible solution where physical space is a concern.

As with the UL 508 products, these units allow for simple addition of fourth pole modules, neutral modules and other accessories. The balance of the line includes two-, three- and four-pole devices for safe isolation of any low voltage circuit. Further, the fusible products employ double-break-per-pole functionality, a safety feature that fully isolates the fusing when the switch is in the OFF position.

In addition to the R5 and R9 products, the new offering also includes a series of smaller footprint 30A, fusible molded-case switch disconnects in a compact design. These R4 (Rotary 489) units are listed to UL 489, and provide a small overcurrent device with short-circuit ratings of 100 kAIC.

The R5, R9 and R4 products have available new, state-of-the-art selector and pistol handle designs to give the final installation an up-to-date, professional look. In addition to the new handles, each offering includes an entirely new line of shafts, auxiliary contacts, terminal shields and other accessories.



Powering business worldwide



R5 Series Non-Fusible
UL 508 (CSA 22.2 No.14)
16–80A

See page 5



R9 Series Non-Fusible—Compact
UL 98 (CSA 22.2 No.4)
30A, 60A and 100A

See page 13



R9 Series Non-Fusible
UL 98 (CSA 22.2 No.4)
100–1200A

See page 20



R9 Series Fusible
UL 98 (CSA 22.2 No.4)
30–800A

See page 28



R9 Series DC Rated
UL 98 (CSA 22.2 No.4)

See page 47



MTS—Manual
Transfer Switches

See page 55



Enclosed Rotary
Disconnects (R5)

See page 64

Eaton delivers power in thousands of products and systems that are answering the demands of today's ever-changing world. We help customers manage power needed for trucks, cars, machinery, aircraft, buildings and entire business enterprises worldwide—and we do it in a way that consumes fewer resources.

Switching Devices

UL®/CSA® Standards for Disconnect Switches	2
R5 Series (UL 508) Non-Fusible 16–80A	
Product Overview	5
Product Selection	6
Accessories	6
Technical Data and Specifications	10
Dimensions	11
R9 Series (UL 98) Non-Fusible 30–1200A	
30–100A (Compact)	
Product Overview	13
Product Selection	14
Technical Data and Specifications	17
Dimensions	18
100–1200A	
Product Overview	20
Product Selection	21
Accessories	22
Technical Data and Specifications	24
Dimensions	25
R9 Series (UL 98) Fusible 30–800A	
Product Overview	28
Product Selection	30
Accessories	34
Technical Data and Specifications	39
Dimensions	41
R9 Series (UL 98) DC Rated Disconnects	
Product Overview	47
Product Selection	48
Accessories	49
Technical Data and Specifications	51
Dimensions	52
MTS—Manual Transfer/Double Throw Switches	
Product Overview	55
Product Selection	56
Accessories	57
Technical Data and Specifications	59
Dimensions	60
Enclosed Rotary Disconnects	
Product Overview	64
Product Selection	65
Dimensions	66

Switching Devices

Introduction



UL®/CSA® Standards for Disconnect Switches

UL 98—Enclosed and Deadfront Switches (CSA C22.2 No. 4)

These requirements cover enclosed or deadfront switches, with or without provision for fuses, at 600V or less. These products are used as disconnecting means without restrictions; they are heavy-duty products requiring 2.00 inches (50.0 mm) minimum of creepage distance between phases, which gives maximum safety for users and installation. The short-circuit withstand of those products goes up to 200 kA.

UL 489—Molded Case Switches (CSA C22.22 No. 5)

These requirements cover molded case circuit breakers, molded case switches and fused molded case switches, rated at 600V or less and 6000A or less.

Typical Control Panel

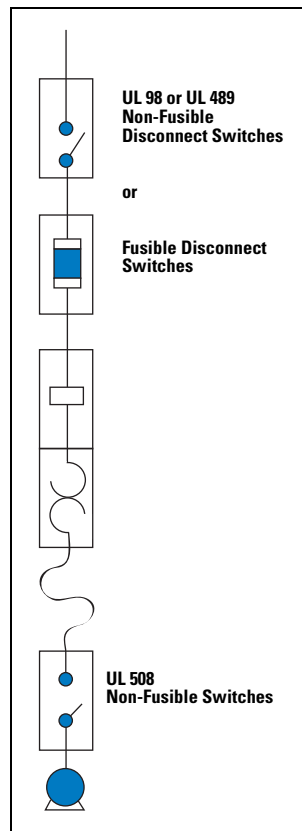

Contents

<i>Description</i>	<i>Page</i>
UL/CSA Standards for Disconnect Switches	2
UL Standards for Electrical Machinery	2
Eaton Solutions for UL 508 and NFPA 79	3

UL Standards for Electrical Machinery

UL 508—Industrial Control Equipment (CSA C22.2 No. 14)

These requirements cover manual, magnetic and solid-state starters and controllers, overload relays, pushbuttons, selector switches and control lights.

These products are smaller, requiring only a creepage distance between phases of 0.50 inch (12.7 mm). Their use as a disconnecting means is limited to local disconnection of motors.

These products can be used as a disconnect means only when they have been additionally tested "suitable as motor disconnect." This additional testing ensures that the switch has a proper closing capacity on a short circuit. UL 508 devices cannot be used as main disconnect of an electrical panel, e.g., at the entrance of control panels.

A manual motor controller marked "suitable as motor disconnect" shall be installed only on the load side of the branch circuit protective device [UL 508A 30.33 and NEC 430.109 (6)].

NFPA® 79 Electrical Standard for Industrial Machinery

The following types of machines are identified as industrial machinery:

- Metalworking machine tools, including machines that cut or form metal
- Plastics machinery
- Wood machinery, including woodworking, laminating and sawmill machines
- Assembly machines
- Material handling machines, including industrial robots and transfer machines
- Inspection and testing machines, including coordinate measuring and in-process gauging machines

Eaton solutions for UL 508A and NFPA 79

The changes in UL 508A and NFPA 79 impact the design and construction of your equipment. Important modifications concern major safety issues, the disconnect means and the interlocking of the enclosure door.

The disconnect shall be operable independent of the door position.

The disconnect must be operable, by qualified persons, independent of the door position without the use of accessory tools or devices.

Note: NFPA 79; Paragraph 5.3.3.1 (5) T.

An operating mechanism for the disconnecting means shall be operable independent of the door position without the use of accessory tools or devices.

Note: UL 508A; Paragraph 66.6.3 c.

The disconnect means is not closable with the enclosure door open, unless an interlock is operated by deliberate action.

The interlocking means shall fulfill the following requirement: Prevent closing of the disconnect means while the enclosure door is open, unless an interlock is operated by deliberate action.

Note: NFPA 79; Paragraph 6.2.3.1.2.

The disconnecting means is not closable with the enclosure door open, unless an interlock is operated by deliberate action.

Note: UL 508A; Paragraph 66.1.5.

Operable independent of the position of the door



Door closed: operation with the external handle through the door.

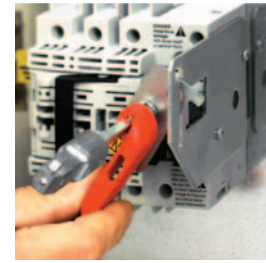

Door open: A robust optional kit with a handle directly fitted on the shaft of the switch allows the operation when the door is open.

Operated by a deliberate action



① Push

Door open: It is necessary to push the handle from OFF to ON. This deliberate action permits the operator to turn and switch ON. This action is necessary as in most cases there is no padlock on the switch when somebody opens the door of an enclosure.



② Turn

ON to OFF action permits the operator to turn and switch ON. That is a major safety issue; switching ON directly without any other action is extremely dangerous. The use of a padlock does not comply with the request of the standard; when the panel door is opened, there is generally no padlock, and anybody can turn the switch ON.

Switching Devices

Introduction

The disconnect means shall be able to be locked in the OPEN position independent of the door position.

The circuit disconnecting device shall be provided with a permanent means, permitting it to be locked in the OFF position only independent of the door position. When locked, remote as well as local closing shall be prevented.

Note: NFPA 79; Paragraph 5.3.3.1 (3).

An operating mechanism for the disconnecting means shall be able to be locked in the OFF position independent of the door position. When locked, closing of the disconnect is not possible.

Note: UL 508A; Paragraph 66.6.3 d.

The interlocking of the enclosure door shall be provided with means to defeat the interlock without removing the power.

The interlocking means required by 66.1.5 shall be provided with all of the following:

- Means to defeat the interlock without removing power, and requires the use of a tool to operate
- Reactivated automatically when all the doors are closed

Note: Added 66.1.5.1 effective March 1, 2007. UL 508A; Paragraph 66.1.5.1.

NFPA 79; Paragraph 6.2.3.1.2 states that the [enclosure] interlocking means shall meet the following requirements:

- Use a device or tool to allow qualified persons to defeat the interlock
- Be reactivated automatically when the door is closed

Locked in the open position independent of the door position



Door close: The external through-the-door handle is padlocked when locked closing of the disconnect is not possible.



Door open: A strong metallic padlock kit allows up to three padlocks. The padlocking means is easily accessible, when locked closing of the disconnect is not possible.

Defeat the interlock without removing the power



A tool allows defeat of the interlock without removing power. The interlocking is reactivated automatically when the door is closed.

R5 Series Non-Fusible 16–80A



Product Overview

R5 Series (UL® 508 listed) products are manually operated modular switches. Load break switching and isolation provide safety solutions for any low voltage circuit, particularly for machine and control circuits. The R5 Series products are manual motor controllers suitable as motor disconnect.

Features, Benefits and Functions

- Up to 65 kAIC short-circuit rating
- Direct or external operation
- Compact footprint
- DIN rail or base mount
- Wide range of accessories
- Open and enclosed devices
- Modular design
- Integrated terminals for additional safety
- Padlockable design (direct, toggle and external handles)
- Product can be reverse fed

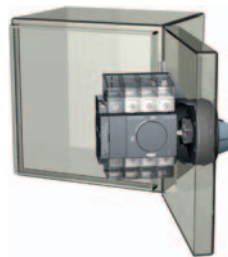

Contents

Description	Page
Product Overview	5
Features, Benefits and Functions	5
Standards and Certifications	5
Product Selection	6
Accessories	6
Technical Data and Specifications	10
Dimensions	11

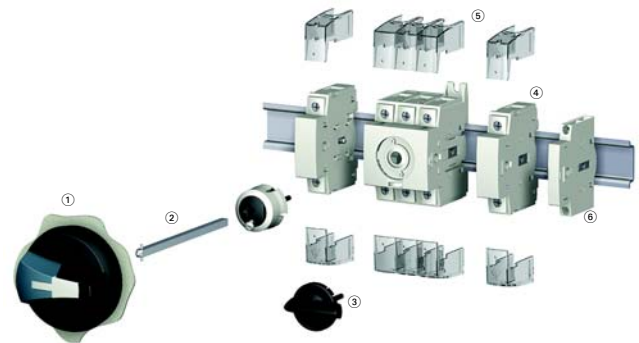

Overview

- ① External front handle
- ② Shaft extension for external handle
- ③ Direct handle
- ④ Switched fourth-pole module
- ⑤ Terminal shroud
- ⑥ Auxiliary contacts

Note: For further details, please see the installation instructions supplied with each device.

Standards and Certifications

Conformity to Standards

- UL 508 listed, Guide NLRV, File E165150
- CSA® C22.2 No.14, File 217736
- IEC 60947-3, EN 60947-3
- CCC
- CE



Switching Devices

R5 Series (UL 508) Non-Fusible 16–80A

Product Selection

Direct Operation



Switch body + Direct handle

External Operation



Switch body + Shaft + External handle

R5 Series



Ampere Rating	Three-Pole Toggle Switch Only ^①	Three-Pole Rotary Switch Only	Direct Handle	Front and Right External Handle SH00 (Choose one)	Front and Right External Handle SH0 (Choose one)	Shaft for SH0 and SH00—5 x 5 mm—In (mm)
16	—	R5A3016U	DHR5	SH00 Black 3R, 12 SHB00N12	SH0 Black 3R, 12 SHB0N12	2.20 (55.5) SF55SH5X5
25	—	R5A3025U				
30	T5A3030U	R5A3030U				3.50 (90.0) SF90SH5X5
40	T5A3040U	R5A3040U				
60	T5B3060U	R5B3060U		SH00 Red 3R, 12 SHR00N12	SH0 Red 3R, 12 SHR0N12	5.90 (150.0) SF150SH5X5
80	T5B3080U	R5B3080U				7.90 (200.0) SF200SH5X5
				SH00 Black 4, 4X SHB00N4X	SH0 Black 4, 4X SHB0N4X	12.60 (320.0) SF320SH5X5
				SH00 Red 4, 4X SHR00N4X	SH0 Red 4, 4X SHR0N4X	

Accessories



Ampere Rating	Switched Fourth-Pole Module	Auxiliary Contacts (Choose one)	Terminal Shrouds	Door Mounting Kit ^②
16	S4PR516	1NO + 1NC AC1N0NC	1P TS1R5A	DMK
25	S4PR525			
30	S4PR530		3P TS3R5A	
40	S4PR540	2NO AC2N0		
60			1P TS1R5B	
80			3P TS3R5B	

Notes

- ^① Toggle version includes direct handle.
- ^② Includes shaft and accessory cap.

Handles

Direct Handle



Direct Handle

Ampere Rating	Handle Color	Catalog Number
16–80	Black	DHR5

Size 00 Handle



Door Interlocked External Handle (Defeatable) ①

Ampere Rating	Handle Color	Handle Size	NEMA Type Rating	Catalog Number
Front and Right Side Operation I–0				
16–80	Black	SH00	3R, 12	SHB00N12
16–80	Black	SH00	4, 4X	SHB00N4X
16–80	Red/Yellow	SH00	3R, 12	SHR00N12
16–80	Red/Yellow	SH00	4, 4X	SHR00N4X
Size 0 Handle				
16–80	Black	SH0	3R, 12	SHB0N12
16–80	Black	SH0	4, 4X	SHB0N4X
16–80	Red/Yellow	SH0	3R, 12	SHR0N12
16–80	Red/Yellow	SH0	4, 4X	SHR0N4X

Shafts

Shaft 5 x 5



Shaft Extensions for External Handle

Description	Ampere Rating	Use with Handle Type	Shaft Length In (mm)	Catalog Number
Standard lengths: 55 mm, 90 mm, 150 mm, 200 mm, 320 mm	16–80	SH00/SH0	2.17 (55.0)	SF055SH5X5
	16–80	SH00/SH0	3.54 (90.0)	SF090SH5X5
For 3/4-pole switches: shafts are for external front and side handle	16–80	SH00/SH0	5.91 (150.0)	SF150SH5X5
	16–80	SH00/SH0	7.87 (200.0)	SF200SH5X5
For 6/8-pole switches and changeover switches: shafts are for external front and side handle	16–80	SH00/SH0	12.60 (320.0)	SF320SH5X5



Guide Cone

Description	Ampere Rating	Use with Handle Type	Catalog Number
The guide cone facilitates an easier connection between the shaft and a Size 00 or Size 0 external selector handle. It allows the shaft up to 10 mm of vertical play when making the connection	16–80	SH00 and SH0	SFGAB

Note

① Allows door to be opened when switch is in the ON position.

Switching Devices

R5 Series (UL 508) Non-Fusible 16–80A

Additional Pole Configurations

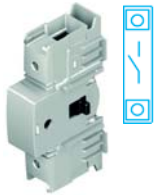
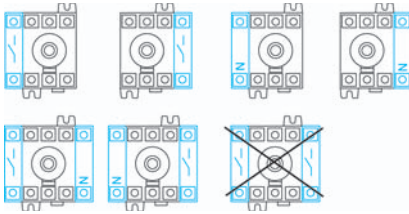

Switched Fourth-Pole Module

Description	Ampere Rating	Number of Poles	Type	Catalog Number
Add one or two poles and transform: <ul style="list-style-type: none"> • Three-pole R5 Series load break switch into a four-pole • Six-pole R5 Series switch into an eight-pole • Three-pole changeover switch into a four-pole 	16	1	Switched	S4PR516
	25	1	Switched	S4PR525
	30	1	Switched	S4PR530
	40	1	Switched	S4PR540

Auxiliary Contact Configurations

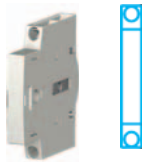
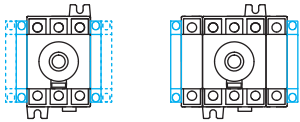

Auxiliary Contact Module

Description	Ampere Rating	Type	Catalog Number
Early-break/same-make and signalization of positions 0 and I by NO + NC or 2NO auxiliary contacts. They can be mounted on the left or on the right side of the device. Two modules maximum.	16–80	1NO + NC	AC1N0NC
	16–80	2NO	AC2N0



Terminal Shrouds

Description	Ampere Rating	Number of Poles	Position	Catalog Number
Line and load protection against direct contact with the terminals or connection parts: single- or three-pole. Advantage: Perforations allowing thermographic inspection.	16–40	1	Line and load	TS1R5A
	16–40	3	Line and load	TS3R5A
	60–80	1	Line and load	TS1R5B
	60–80	3	Line and load	TS3R5B

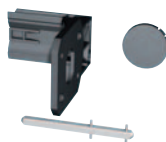

Door/Panel Mounting Kit

Description	Ampere Rating	Number of Poles	Catalog Number
This kit enables direct mounting of the switch on the door panel. Moreover, the connection clamps of the switch are always accessible. The external handle is quick and easy to install due to an internal locking nut mounted on the inside of the enclosure.	16–80	3 and 4	DMK ^①

Note

^① Includes shaft and accessory cap.

Technical Data and Specifications

UL 508 (CSA 22.2 No. 14) Manual Motor Controller “Suitable as Motor Disconnect” from 16–80A

Technical Characteristics	16A	25A	30A	40A	60A	80A
Approvals	UL 508/CSA 22.2 No. 14	UL 508/CSA 22.2 No. 14	UL 508/CSA 22.2 No. 14	UL 508/CSA 22.2 No. 14	UL 508/CSA 22.2 No. 14	UL 508/CSA 22.2 No. 14
Short-circuit rating at 600 Vac (kA) ①	10/65	10/65	10/65	10/65	50/65	50/65
Branch circuit fuse type	J	J	J	J	J	J
Maximum fuse rating	60/30A	60/30A	60/30A	60/30A	100/60A	100/60A
Maximum UL Horsepower Ratings/Maximum Motor FLA Current, Three-Phase						
208 Vac	3/10.6	7.5/24.2	7.5/24.2	7.5/24.2	15/46.2	15/46.2
220–240 Vac	5/15	7.5/22	7.5/22	7.5/22	15/42	20/54
440–480 Vac	10/14	15/21	15/21	20/27	30/40	40/52
600 Vac	10/11	20/22	20/22	25/27	30/32	40/41
Connection						
Wire range (AWG), solid, single cable	#14–#10	#14–#10	#14–#10	#14–#10	#14–#10	#14–#10
Wire range (AWG), solid, two cables	2x #12	2x #12	2x #12	2x #12	2x #12	2x #12
Wire range (AWG), stranded, single cable	#14–#4	#14–#4	#14–#4	#14–#4	#14–#1	#14–#1
Wire range (AWG), stranded, two cables	2x (#14–#12)	2x (#14–#12)	2x (#14–#12)	2x (#14–#12)	2x (#10–#6)	2x (#10–#6)
Mechanical Characteristics						
Endurance, number of mechanical cycles	10,000	10,000	10,000	10,000	10,000	10,000
Auxiliary Contacts						
Electrical characteristics	A300	A300	A300	A300	A300	A300

IEC 60947-3 Characteristics

Technical Characteristics		16A	25A	32A	40A	63A	80A
Rated Operational Currents I_o (A)							
Rated Voltage	Load Duty Category	A/B ②	A/B ②	A/B ②	A/B ②	A/B ②	A/B ②
500 Vac	AC-22 A/AC-22 B	16/16	25/25	32/32	40/40	63/63	80/80
500 Vac	AC-23 A/AC-23 B	16/16	25/25	25/25	25/25	63/63	63/63
690 Vac	AC-21 A/AC-21 B	16/16	25/25	32/32	40/40	63/63	80/80
690 Vac	AC-22 A/AC-22 B	16/16	25/25	32/32	32/40	40/63	63/80
690 Vac	AC-23 A/AC-23 B	16/16	25/25	25/25	25/25	40/40	40/40
Thermal Current I_{th} at 40°C (A)							
Thermal current I_{th} (40°C) ③		16	25	32	40	63	80
Rated insulation voltage U_i (V)		800	800	800	800	800	800
Rated impulse withstand voltage U_{imp} (kV)		8	8	8	8	8	8
Operational Power in AC-23 (kW)							
At 400 Vac without prebreaking AC in AC-23 (kW) ④		7.5	11	15	18.5	30	37
At 500 Vac without prebreaking AC in AC-23 (kW) ④		7.5	11	15	15	30	37
At 690 Vac without prebreaking AC in AC-23 (kW) ④		7.5	15	18.5	18.5	30	37
Fuse Protected Short-Circuit Withstand (kA rms Prospective)							
Prospective short-circuit current (kA rms) ⑤		50	50	50	50	50	50
Associated fuse rating (A) ⑤		16	25	32	40	63	80
Overload Capacity (U_e 415 Vac)							
Rated short-time withstand current 0.3 s. I_{CV} (kA rms) ⑥		2.5	2.5	2.5	2.5	3	3
Rated short-circuit making capacity I_{cm} (kA peak) ⑥		6	6	6	6	9	9
Connection							
Minimum Cu cable cross section (mm ²)		1.5	1.5	1.5	1.5	2.5	2.5
Maximum Cu cable section (mm ²)		16	16	16	16	35	35
Tightening torque minimum/maximum (Nm)		2/2.2	2/2.2	2/2.2	2/2.2	3.5/3.85	3.5/3.85

Notes

- ① Short-circuit rating achieved when used with respective fuse type and maximum fuse rating.
- ② A/B: Category with index A = frequent operation; category with index B = infrequent operation.
- ③ De-rate 1% per °C above 40°C, max 70°C.
- ④ The power value is given for information only; the current values vary from one manufacturer to another.
- ⑤ For a rated operating voltage, $U_e = 400$ Vac.

Dimensions

Approximate Dimensions in Inches (mm)

R5 Series 16–80A

Toggle Operation

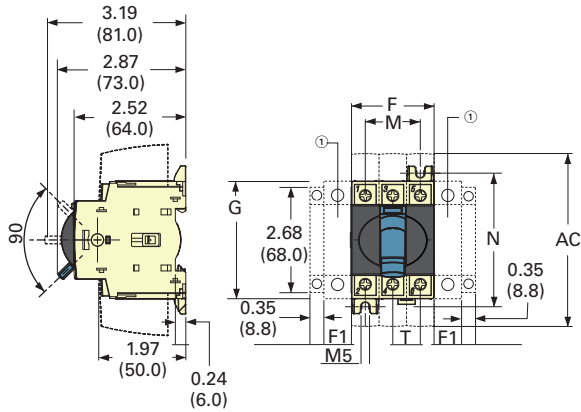

Direct Operation with Handle

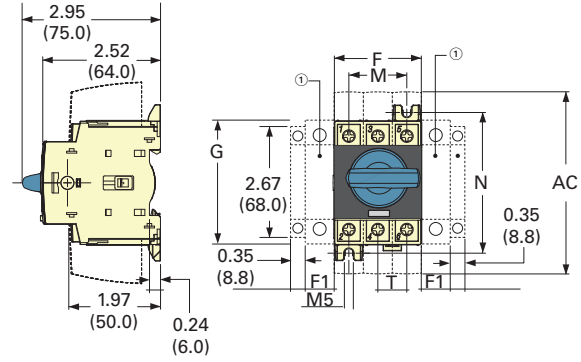

External Front Operation

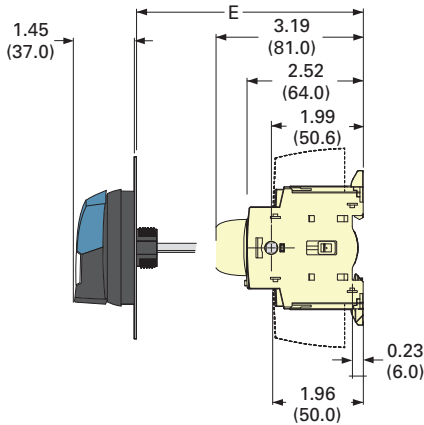

External Side Operation

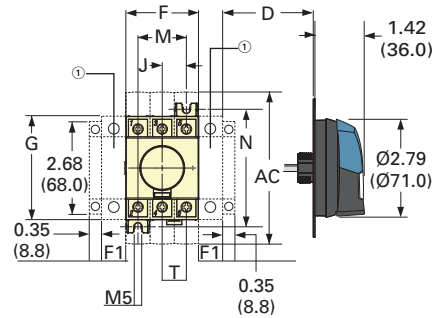

R5 Series ^②

Ampere Rating	Overall Dimensions				Terminal Shrouds	Switch Body				Switch Mounting		Connection Terminal
	D Min.	D Max.	E Min.	E Max.	AC	F	F1	G	J	M	N	T
16–40	1.18 (30.0)	9.25 (235.0)	3.94 (100.0)	14.65 (372.0)	4.33 (110.0)	1.77 (45.0)	0.59 (15.0)	2.68 (68.0)	0.59 (15.0)	1.18 (30.0)	2.95 (75.0)	0.59 (15.0)
63–80	1.18 (30.0)	9.25 (235.0)	3.94 (100.0)	14.65 (372.0)	4.33 (110.0)	2.06 (52.5)	0.69 (17.5)	2.99 (76.0)	0.69 (17.5)	1.38 (35.0)	3.35 (85.0)	0.69 (17.5)

Notes

- ① One switched fourth-pole module (one per device maximum) or one unswitched neutral pole or one auxiliary contact.
- ② Maximum four additional blocks.

Switching Devices

R5 Series (UL 508) Non-Fusible 16–80A

Approximate Dimensions in Inches (mm)

Door Drilling—SH00/SH0

With Fixing Nut

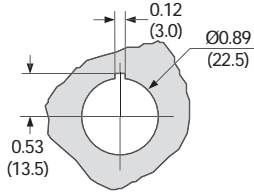

With Four Fixing Screws

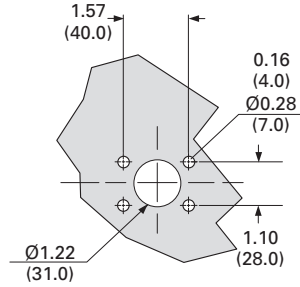

Operating Handle—SH00/SH0

Front and Right Side Operation

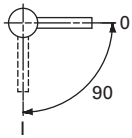

Front Operation for R5 Changeover Switches I-0-II or I-I+II-II

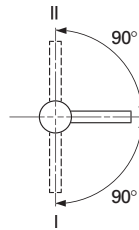



Contents

Description	Page
Product Overview	13
Features, Benefits and Functions	13
Standards and Certifications	13
Product Selection	14
Technical Data and Specifications	17
Dimensions	18

Product Overview

The R9 Series (UL® 98 listed) non-fusible 30–100A compact range ensures making or breaking on load and safety isolation for low voltage electrical circuits, particularly for machine control circuits up to 600V.

Features, Benefits and Functions

- Rating three-pole from 30A to 100A
- Direct or external operation handle (padlockable in ON position)
- Double breaking per phase

Standards and Certifications

- UL 98, File E222859
- CSA® 22.2 No. 4, File 217736
- IEC 60947-3
- EN 60947-3
- CE

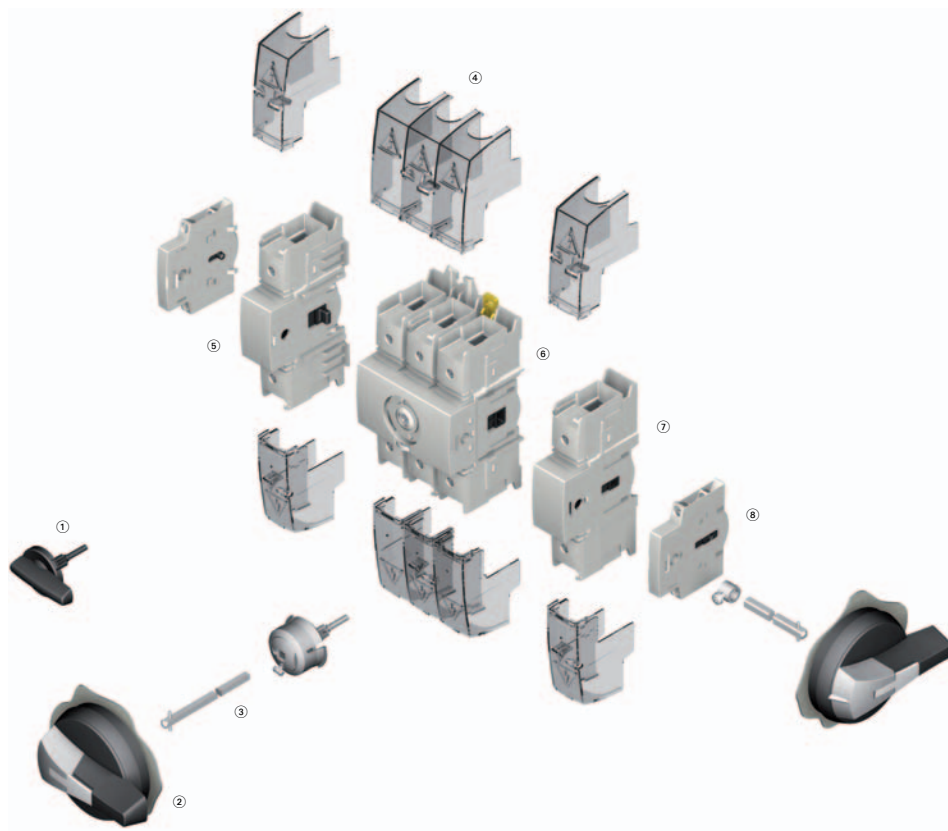

Overview

- ① Direct handle
- ② Door interlocked external handle
- ③ Shaft extension
- ④ Terminal shrouds
- ⑤ Unswitched neutral pole
- ⑥ Switch body
- ⑦ Switched fourth-pole module
- ⑧ Modular type auxiliary contacts

Note: For further details, please see the installation instructions supplied with each device.

Switching Devices

R9 Series (UL 98) Non-Fusible 30–100A Compact

Product Selection

Direct Operation



External Operation



R9 Series 30–100A

Ampere Rating (Frame)	Number of Poles	Switch Body Only	Direct Handle	Front and Right External Handle SH00 (Choose one)	Front and Right External Handle SH0 (Choose one)	Shaft for SH0 and SH00 Handles—In (mm) (Choose one)	Switched Fourth-Pole Module	Auxiliary Contacts (Choose one)	Terminal Shrouds (Choose one)
30 (C-Frame)	3	R9C3030U	DHR9	SH00 Black 3R, 12 SHB00N12	SH0 Black 3R, 12 SHB0N12	2.20 (55.5) SF55SH5X5	S4PR930	1NO + 1NC AC1NONC	1P TS1R9
60 (C-Frame)	3	R9C3060U		SH00 Red 3R, 12 SHR00N12	SH0 Red 3R, 12 SHR0N12	3.50 (90.0) SF90SH5X5	S4PR960	2NO AC2NO	3P TS3R9CV
100 (C-Frame)	3	R9C3100U		SH00 Black 4, 4X SHB00N4X	SH0 Black 4, 4X SHB0N4X	5.91 (150.0) SF150SH5X5	S4PR9100		
				SH00 Red 4, 4X SHR00N4X	SH0 Red 4, 4X SHR0N4X	7.87 (200.0) SF200SH5X5			
						12.60 (320.0) SF320SH5X5			

Handles

Direct Handle



Direct Handle

Ampere Rating	Handle Color	Catalog Number
30–100	Black	DHR9

Size 00 Handle



Door Interlocked External Handle ^①

Ampere Rating	Handle Color	Handle Size	NEMA Type Rating	Catalog Number
Front and Right External Handle				
30–100	Black	SH00	3R, 12	SHB00N12
30–100	Black	SH00	4, 4X	SHB00N4X
30–100	Red	SH00	3R, 12	SHR00N12
30–100	Red	SH00	4, 4X	SHR00N4X
30–100	Black	SH0	3R, 12	SHB0N12
30–100	Black	SH0	4, 4X	SHB0N4X
30–100	Red	SH0	3R, 12	SHR0N12
30–100	Red	SH0	4, 4X	SHR0N4X

Size 0 Handle



Shafts

Shaft 5 x 5



Shaft Extensions for External Handle

Description	Ampere Rating	Use with Handle Type	Shaft Length In (mm)	Catalog Number
Standard lengths: 55 mm, 90 mm, 150 mm, 200 mm, 320 mm	30–100	SH00/SH0	2.20 (55.5)	SF55SH5X5
	30–100	SH00/SH0	3.50 (90.0)	SF90SH5X5
Shafts are for external front and right side handles	30–100	SH00/SH0	5.91 (150.0)	SF150SH5X5
	30–100	SH00/SH0	7.87 (200.0)	SF200SH5X5
	30–100	SH00/SH0	12.60 (320.0)	SF320SH5X5



Guide Cone

Description	Ampere Rating	Use with Handle Type	Catalog Number
The guide cone facilitates an easier connection between the shaft and a Size 00 or Size 0 external selector handle. It allows the shaft up to 10 mm of vertical play when making the connection	16–80	SH00 and SH0	SFGAB

Note

^① Allows door to be opened when switch is in the ON position.

Switching Devices

R9 Series (UL 98) Non-Fusible 30–100A Compact

Additional Pole Configurations

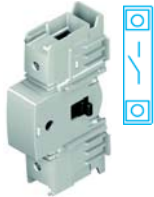
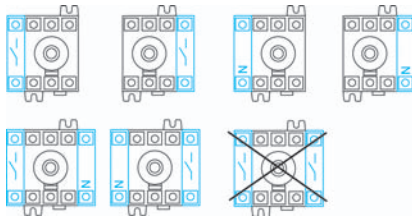

Switched Fourth-Pole Module

Description	Ampere Rating	Number of Poles	Type	Catalog Number
Transforms a three-pole, R9 Series load break switch into a four-pole	30	1	Switched	S4PR930
	60	1	Switched	S4PR960
	100	1	Switched	S4PR9100

Auxiliary Contact Configurations

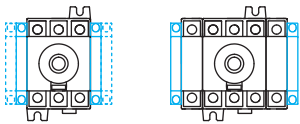

Auxiliary Contacts

Description	Ampere Rating	Type	Catalog Number
Early-break/same-make and signalization of positions 0 and I by NO + NC or 2NO auxiliary contacts. They can be mounted on the left or on the right side of the device. Maximum four auxiliary contacts (two modules)	30–100	1NO + 1NC	AC1N0NC
	30–100	2NO	AC2NO



Terminal Shrouds

Description	Ampere Rating	Number of Poles	Position	Catalog Number
Line and load protection against direct contact with the terminals or connection parts: single- or three-pole Advantage: Perforations allowing thermographic inspection	30–100	1	Line and load	TS1R9
	30–100	3	Line and load	TS3R9CV

Technical Data and Specifications

UL and CSA Characteristics

UL 98/CSA 22.2 No. 4

Technical Characteristics	30A	60A	100A
Short-circuit rating at 480 Vac (kA) ①	100 kA	100 kA	100 kA
Short-circuit rating at 600 Vac (kA) ①	100 kA	100 kA	25 kA
Fuse type	J	J	J
Maximum fuse rating (A)	30	60	100
Maximum Horsepower Rating/Maximum Motor FLA Three-Phase			
220–240 Vac	10/28	20/54	20/54
440–480 Vac	20/27	40/52	50/65
600 Vac	25/27	50/52	50/52
Maximum Horsepower Rating/Maximum Motor FLA Single-Phase			
120 Vac	2/24	3/34	5/56
240 Vac	5/28	10/50	10/50
Connection			
Solid, 1 wire	#12–10	#12–10	#12–10
Stranded, 1 wire	#12–2/0	#12–2/0	#12–2/0
Auxiliary Contacts			
Electrical characteristic	A300	A300	A300

IEC 60647-3 Characteristics

Technical Characteristics	32A	63A	100A
Thermal Current I_{th} at 40°C (A)			
Thermal current I_{th} (40°C)	30	60	100
Rated insulation voltage U_i (V)	800	800	800
Rated impulse withstand voltage U_{imp} (kV)	8	8	8
Rated Operation Currents I_o (A)			
Load Duty Category	Rated Voltage	A ②	A ②
400 Vac	AC-22 A	32	63
400 Vac	AC-23 A	32	63
690 Vac	AC-22 A	32	63
690 Vac	AC-23 A	32	63
Operational Power in AC-23 (kW)			
At 400 Vac without prebreak AC in AC-23 (kW) ③④	15	30	45
At 500 Vac without prebreak AC in AC-23 (kW) ③④	15	30	45
At 690 Vac without prebreak AC in AC-23 (kW) ③④	18.5	30	45
Overload Capacity (U_o 415 Vac)			
Rated short-time making capacity I_{cm} (kA peak) ⑤	12	12	12
Connection			
Minimum Cu cable cross section (mm ²)	2.5	2.5	10
Maximum Cu cable section (mm ²)	70	70	70

Notes

- ① Short-circuit rating achieved when used with respective fuse type and maximum fuse rating.
- ② Category with index A = frequent operation.
- ③ A/B: Category with index A = frequent operation; category with index B = infrequent operation.
- ④ The power value is given for information only; the current values vary from one manufacturer to another.
- ⑤ For a rated operating voltage, $U_o = 400$ Vac.

Switching Devices

R9 Series (UL 98) Non-Fusible 30–100A Compact

Dimensions

R9 Series 30–100A Compact

Approximate Dimensions in Inches (mm)

Direct Operation

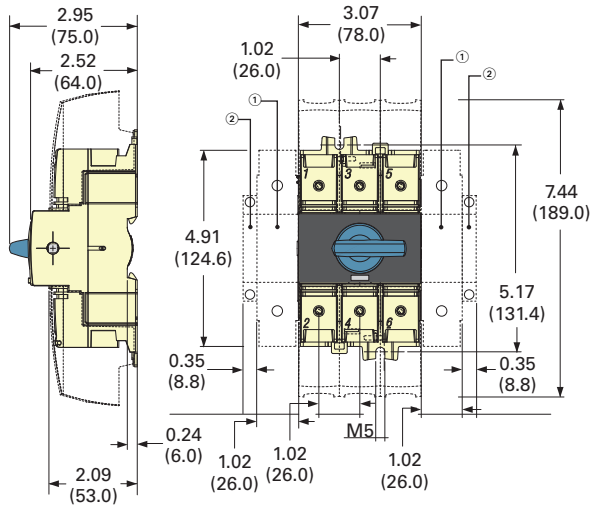

External Front Operation

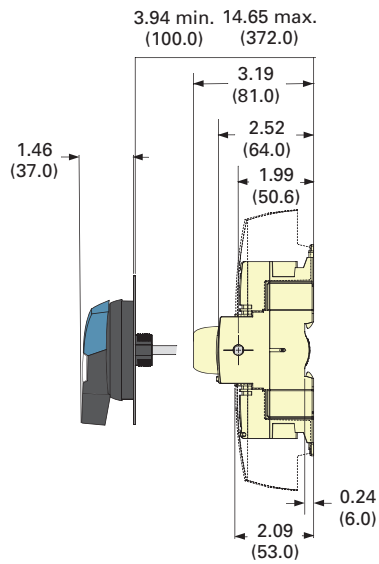

External Side Operation

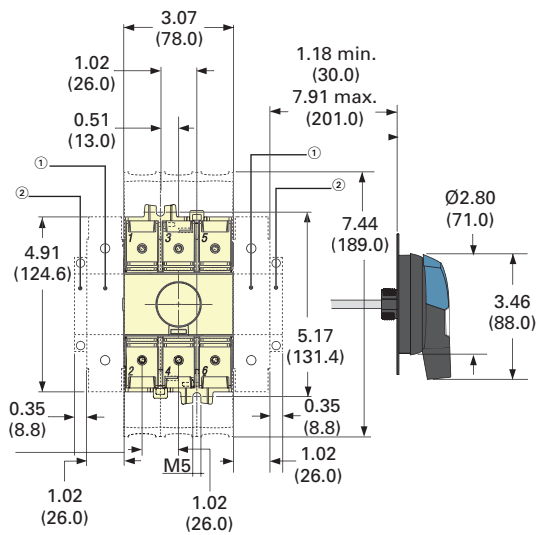

Notes

- ① One switched fourth-pole module (one per device maximum) and/or one unswitched neutral pole.
- ② Auxiliary contact.

Approximate Dimensions in Inches (mm)

R9 Series 30–100A Compact

Door Drilling—SH00/SH0

With Fixing Nut

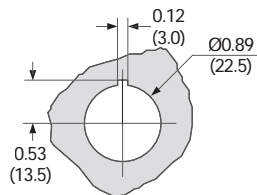

With Four Fixing Screws

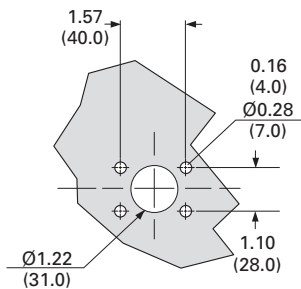

Operating Handle—SH00/SH0

Front and Right Side Operation

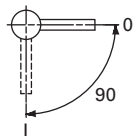

Switching Devices

R9 Series (UL 98) Non-Fusible 100–1200A



Contents

Description	Page
Product Overview	20
Features, Benefits and Functions	20
Standards and Certifications	20
Product Selection	21
Accessories	22
Technical Data and Specifications	24
Dimensions	25

Product Overview

The R9 Series (UL® 98 listed) non-fusible 100–1200A are manually operated multipole load-break switches. Quick-make, quick-break design provides safety isolation for any low voltage circuit.

Features, Benefits and Functions

- High thermal and dynamic withstand ratings
- Arduous categories of applications
- High electrical and mechanical endurences

Standards and Certifications

- UL 98, File E222859
- CSA® 22.2 No. 4, File 217736
- IEC 60947-3
- EN 60947-3

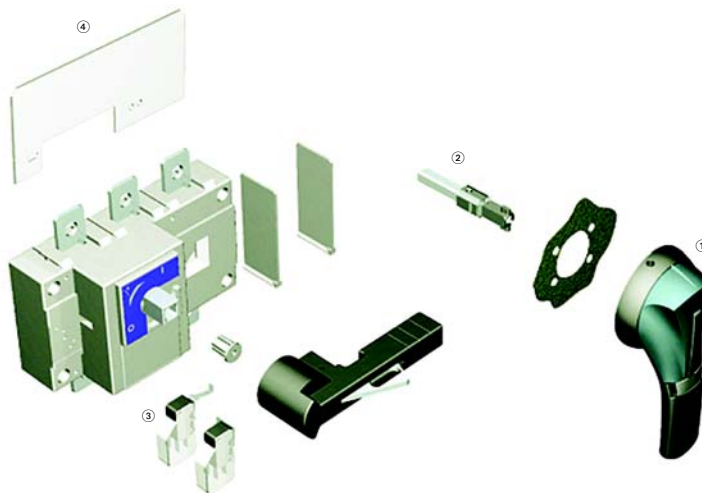

Overview

- ① External front handle
- ② Shaft extensions for external handle
- ③ Configurable U-type ACs, for pre-break and signalling or TEST
- ④ Terminal screens

Note: For further details, please see the installation instructions supplied with each device.

Product Selection

Direct Operation

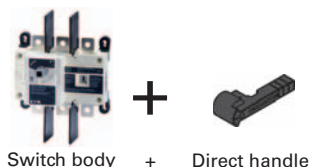

External Operation

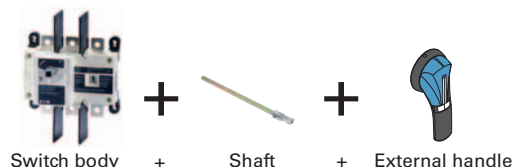

R9 Series Non-Fusible 100–1200A

Ampere Rating (Frame)	Number of Poles	Switch Body Only	Direct Handle	Door Interlocked External Pistol Handle (Choose one)	Shaft Extensions for External Handle—In (mm) (Choose one)	Auxiliary Contacts	Terminal Screens (Choose one)	Terminal Lugs ^①	
100 (D-Frame)	3	R9D3100U	DHR9DE	Size 2, Black 1, 3R, 12 Defeatable PHB2N12F	7.90 (200.0) SF200PH10X10	1NO + 1NC AC1N0NCDE AC1N0NCDELL	3-pole, Line side only TS3R9DT	LK3R9DL	
	4	R9D4100U							LK4R9DL
200 (D-Frame)	3	R9D3200U	DHR9DE	Size 2, Red 1, 3R, 12 Defeatable PHR2N12F	12.60 (320.0) SF320PH10X10	2NO + 2NC AC2N0NCDE AC2N0NCDELL	3-pole, Load side only TS3R9DB	LK3R9DL	
	4	R9D4200U							LK4R9DL
400 (E-Frame)	3	R9E3400U	DHR9DE	Size 2, Black 4, 4X Defeatable PHB2N4XF	15.70 (400.0) SF400PH10X10	2NO + 2NC AC2N0NCDE AC2N0NCDELL	4-pole, Line or load side TS4R9DTB	LK3R9EM	
		4							R9E4400U
	3	R9F3600U		DHR9FG	Size 3, Black 4, 4X Defeatable PHB3N4XF	7.90 (200.0) SF200PH15X12	1NO AC U Type AC1N0R9 ^②	TS3R9F ^③	LK3R9FN
		4							
800 (G-Frame)	3	R9G3800U	DHR9FG	Size 3, Red 4, 4X Defeatable PHR3N4XF	12.60 (320.0) SF320PH15X12	1NC AC U Type AC1NCR9 ^②	TS4R9F ^③ TS3R9FFS ^④	LK6R9G	
	4	R9G4800U							LK8R9G
1000 (G-Frame)	3	R9G31000U	DHR9FG	Size 4, Black 4, 4X Defeatable PHB4N4XF	1.70 (400.0) SF400PH15X12		TS3R9G ^③ TS3R9GFS ^④	LK6R9G	
	4	R9G41000U							LK8R9G
1200 (G-Frame)	3	R9G31200U	DHR9FG	Size 4, Red 4, 4X Defeatable PHR4N4XF			TS4R9G ^③		
	4	R9G41200U							

Notes

- ① Each catalog number is for line or load side. For both line and load, please order two sets.
- ② Auxiliary contact requires holder (catalog number ACHFG) when used on F and G-Frame switches (non-fusible 600–1200A).
- ③ Top (line side) supplied as standard.
- ④ FS suffix = Finger Safe.

Switching Devices

R9 Series (UL 98) Non-Fusible 100–1200A

Accessories

Direct Handle



Direct Handle

Description	Ampere Rating	Handle Color	Catalog Number
Front operation	100–400	Black	DHR9DE
	600–1200	Black	DHR9FG

PH2 and PH3 Types



Door Interlocked External Handle—Front Operation

Description	Ampere Rating	Switch Frame	Handle Type	Handle Color	NEMA Type	Defeatable ^①	Catalog Number
The door interlocked external handle includes one lockable handle and one escutcheon. For dimensions, see Page 27.	100–400	D/E	PH2	Black	1,3R,12	Yes	PHB2N12F
	100–400	D/E	PH2	Red	1,3R,12	Yes	PHR2N12F
	100–400	D/E	PH2	Black	4,4X	Yes	PHB2N4XF
	100–400	D/E	PH2	Red	4,4X	Yes	PHR2N4XF
	600–1200	F/G	PH3	Black	4,4X	Yes	PHB3N4XF
	600–1200	F/G	PH3	Red	4,4X	Yes	PHR3N4XF
	600–1200	F/G	PH4	Black	4,4X	Yes	PHB4N4XF
	600–1200	F/G	PH4	Red	4,4X	Yes	PHR4N4XF

PH4 Type



Shaft Extensions



Shaft Extensions for External Front Handle

Front Operation

Use	Ampere Rating (Frame)	Handle Type	Shaft Length In (mm)	Catalog Number
Standard lengths: 200 mm, 320 mm, 400 mm, 500 mm	100–400 (D-, E-Frame)	PH2	7.90 (200.0)	SF200PH10X10
	100–400 (D-, E-Frame)	PH2	12.60 (320.0)	SF320PH10X10
	100–400 (D-, E-Frame)	PH2	15.70 (400.0)	SF400PH10X10
	100–400 (D-, E-Frame)	PH2	19.70 (500.4)	SF500PH10X10
	600–1200 (F-, G-Frame)	PH3/PH4	7.90 (200.0)	SF200PH15X12
	600–1200 (F-, G-Frame)	PH3/PH4	12.60 (320.0)	SF320PH15X12
	600–1200 (F-, G-Frame)	PH3/PH4	15.70 (400.0)	SF400PH15X12

Shaft Length Minimum Dimensions (X)—Inches (mm)

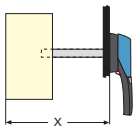

Description	Ampere Rating (Frame)	X In (mm)	Length In (mm)	Catalog Number
Standard lengths: • 7.90 (200.6) • 12.60 (320.0) • 5.70 (398.8)	100–400 (D-, E-Frame)	5.31–10.43 (135.0–265.0)	7.90 (200.6)	SF200PH10X10
		5.31–10.43 (135.0–385.0)	12.60 (320.0)	SF320PH10X10
		5.31–10.43 (135.0–465.0)	15.70 (398.8)	SF400PH10X10
		5.31–22.20 (135.0–565.0)	19.70 (500.4)	SF500PH10X10
600–1200 (F-, G-Frame)	8.70–13.50 (221.0–343.0)	7.90 (200.6)	SF200PH15X12	
	8.70–18.23 (221.0–463.0)	12.60 (320.0)	SF320PH15X12	
	8.70–21.38 (221.0–543.0)	15.70 (398.8)	SF400PH15X12	

Note

① Allow the door to be opened when the switch is in 1 (ON) position.



Auxiliary Contacts ^①

Description	Ampere Rating (Frame)	Number of AC	AC Type	Catalog Number
100–200A, up to two ACs max. 400A, up to two ACs max.	100–400 (D-, E-Frame)	1NO / 1NC	Standard	AC1N0NCDE
		1NO / 1NC	Low Level ^②	AC1N0NCDELL
		2NO / 2NC	Standard	AC2N0NCDE
		2NO / 2NC	Low Level ^②	AC2N0NCDELL
600–1200A, up to four ACs max.	600–1200 (F-, G-Frame)	1NO	Standard	AC1N0R9 ^③
		1NC	Standard	AC1NCR9 ^③
Auxiliary contact holder (for use with AC1N0R9 and AC1NCR9)	600–1200 (F-, G-Frame)	—	—	ACHFG



Terminal Screens



Description	Maximum Ampere Rating (Frame)	Number of Poles	Line/Load Side	Catalog Number	
Line and load protection against direct contact with terminals or connection parts. Line side terminal shrouds are included standard on 600–1200A non-fusible switches. Shrouds are not included on the 100–400A.	100–200 (D-Frame)	3	Line	TS3R9DT	
		3	Load	TS3R9DB	
		4	Line or load	TS4R9DTB	
		400 (E-Frame)	3	Line	TS3R9ET
			3	Load	TS3R9EB
		600 (F-Frame)	4	Line or load	TS4R9ETB
	3		Line or load	TS3R9F	
	800–1200 (G-Frame)	4	Line or load	TS4R9F	
		3	Line or load	TS3R9G	
	4	Line or load	TS4R9G		



Line and Load Terminal Lugs

Description	Maximum Ampere Rating (Frame)	Number of Poles	Number of Lugs/Pole	Lug Capacity/Phase	Cable Type	Catalog Number
Connection of copper cables on to the terminals (no spade lugs). Each kit includes lugs for line or load side. For line and load side, order two kits. For dimensions, see Page 26.	100–200 (D-Frame)	3	1	#6–300 kcmil	Cu/Al	LK3R9DL
		4	1	#6–300 kcmil	Cu/Al	LK4R9DL
	400 (E-Frame)	3	1	#2–600 kcmil	Cu/Al	LK3R9EM ^④
		4	1	#2–600 kcmil	Cu/Al	LK4R9EM ^④
	600 (F-Frame)	3	1	(2) #2–600 kcmil	Cu/Al	LK3R9FN
		4	1	(2) #2–600 kcmil	Cu/Al	LK4R9FN
800–1200 (G-Frame)	3	2	2x (2) #2–600 kcmil	Cu/Al	LK6R9G	
	4	2	2x (2) #2–600 kcmil	Cu/Al	LK8R9G	

Notes

- ^① Early-break/same-make.
- ^② Gold plated for minimal resistance—for PLC applications.
- ^③ Requires use of ACHFG auxiliary contact holder for F- and G-Frame switches.
- ^④ For two-hole lug, consult factory.

Technical Data and Specifications

UL and CSA Characteristics

Technical Characteristics		100A	200A	400A	600A	800A	1000A	1200A
Short circuit rating at 600 Vac (kA) ^①		200 kA	200 kA	200 kA	200 kA	200 kA	100 kA	100 kA
Fuse type		J	J	J	J	L	L	L
Maximum fuse rating (A)		100	200	400	600	800	1000	1200
Maximum Horsepower Rating/Maximum Motor FLA Three-Phase								
220–240 Vac		30/80	75/192	125/312	200/480	200/480	200/480	200/480
440–480 Vac		75/96	150/180	250/302	400/477	500/590	500/590	500/590
600 Vac		100/99	200/192	350/336	350/336	500/472	500/472	500/472
Maximum Horsepower Rating/Maximum Motor FLA Direct Current								
125 Vdc	Two-pole in series	10/76	15/112	20/148	20/148	—	—	—
250 Vdc	Three-pole in series	15/55	15/55	50/173	50/173	—	—	—
Connection								
Minimum connection section/AWG		#6	#6	#2	2 x #2	2 x #2	4 x #2	4 x #2
Maximum connection section/AWG		300 kcmil	300 kcmil	600 kcmil	2 x 600 kcmil	2 x 600 kcmil	4 x 600 kcmil	4 x 600 kcmil
Auxiliary Contacts								
Electrical characteristics		A300	A300	A300	A600	A600	A600	A600

IEC 60947-3 Characteristics

Technical Characteristics		100A	200A	400A	600A	800A	1000A	1200A
Rated insulation voltage U_i (V)		1000	1000	1000	1000	1000	1000	1000
Rated impulse withstand voltage U_{imp} (kV)		8	8	8	12	12	12	12
Rated Operational Currents I_e (A)								
Rated Voltage	Load Duty Category	A ^②	A ^②	A ^②	A ^②	A ^②	A ^②	A ^②
400 Vac	AC-22 A	100	200	400	630	800	1000	1200
400 Vac	AC-23 A	100	200	400	630	800	1000	1000
690 Vac	AC-22 A	100	200	400	500	630	630	630
690 Vac	AC-23 A	100	200	315	200	400	400	400
Connection								
Minimum Cu cable cross section (mm ²)		35	70	185	2 x 150	2 x 185	2 x 240	—
Minimum Cu busbar section (mm ²)		—	—	—	2 x 30 x 5	2 x 40 x 5	2 x 50 x 5	2 x 60 x 5
Operational Power in Ac-23 (kW)								
At 400 Vac without prebreaking AC in AC23 (kW) (2 x 3)		51	100	220	355	450	560	560
At 500 Vac without prebreaking AC in AC23 (kW) (2 x 3)		63	140	280	450	560	560	560
At 690 Vac without prebreaking AC in AC23 (kW) (2 x 3)		90	185	185	185	400	400	400
Overload Capacity (U_e 415 Vac)								
Rated short-circuit making capacity I_{cm} (kA peak) ^③		17.6	32	48	48	75	48	75

Notes

- ① Short-circuit rating achieved when used with respective fuse type and maximum fuse rating.
- ② Category with index A = frequent operation.
- ③ For a rated operating voltage, $U_i = 400$ Vac.

Dimensions

Approximate Dimensions in Inches (mm)

Front Operation—D- and E-Frames

R9 Series Non-Fusible 100–400A

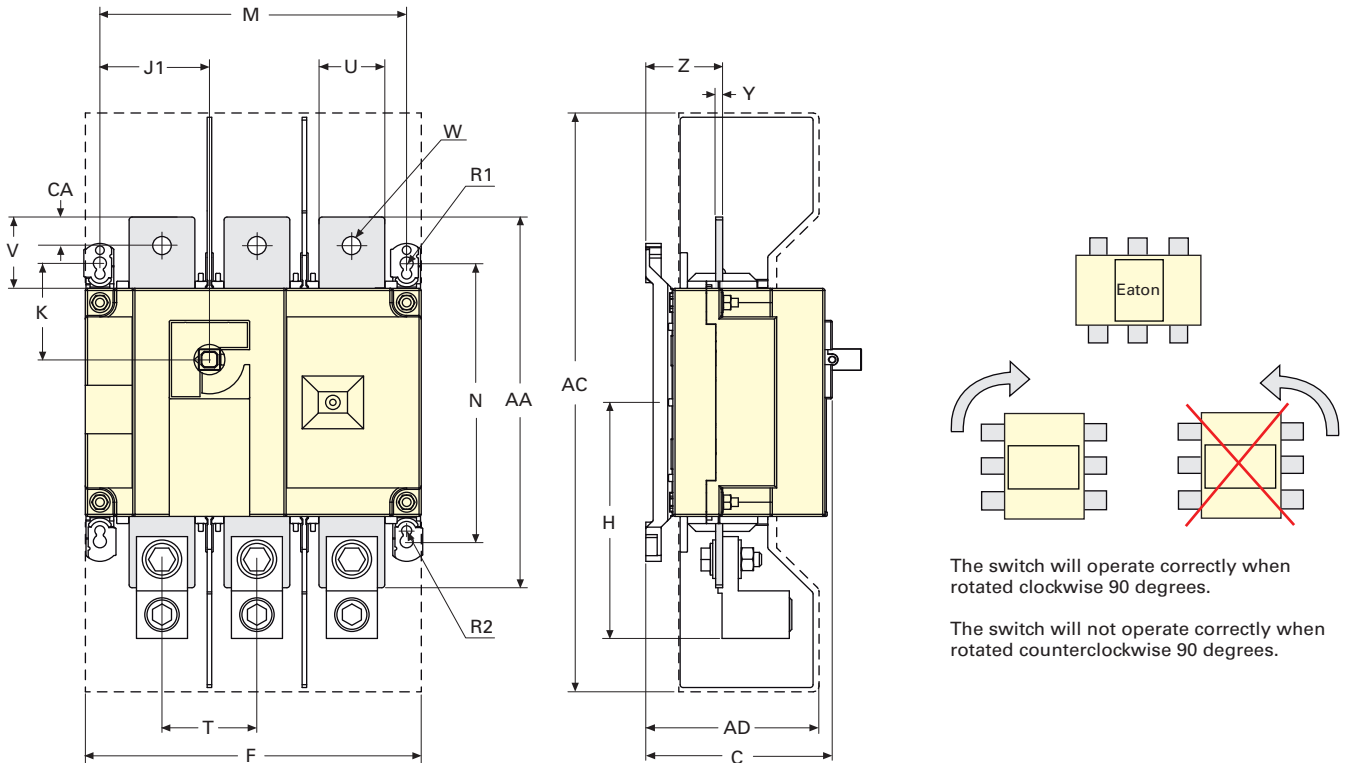

The switch will operate correctly when rotated clockwise 90 degrees.

The switch will not operate correctly when rotated counterclockwise 90 degrees.

Ampere Rating (A)	Overall Dimensions— In (mm)	Terminal Shrouds		Switch Body					
		AC	AD	F 3P	F 4P	H	J1 3P	J1 4P	K
100	3.72 (94.6)	10.10 (256.0)	3.05 (77.5)	7.09 (180.0)	9.06 (230.0)	4.22 (107.0)	2.17 (55.0)	4.13 (105.0)	1.80 (45.6)
200	3.72 (94.6)	10.10 (256.0)	3.05 (77.5)	7.09 (180.0)	9.06 (230.0)	4.22 (107.0)	2.17 (55.0)	4.13 (105.0)	1.80 (45.6)
400	4.92 (128.0)	16.00 (406.0)	4.15 (115.0)	9.05 (230.0)	11.40 (290.0)	6.53 (166.0)	2.95 (75.0)	5.31 (135.0)	2.65 (67.5)

Ampere Rating (A)	Switch Mounting				Connection									
	M 3P	M 4P	N	R1	R2	T	U	V	W	Y	Z	AA	AC	
100	6.30 (160.0)	8.27 (210.0)	5.31 (135.0)	0.35 (9.0)	0.27 (7.0)	1.97 (50.0)	0.98 (25.0)	1.18 (30.0)	0.43 (11.0)	0.14 (3.5)	1.35 (34.4)	6.30 (160.0)	0.60 (15.0)	
200	6.30 (160.0)	8.27 (210.0)	5.31 (135.0)	0.35 (9.0)	0.27 (7.0)	1.97 (50.0)	0.98 (25.0)	1.18 (30.0)	0.43 (11.0)	0.14 (3.5)	1.35 (34.4)	6.30 (160.0)	0.60 (15.0)	
400	8.26 (210.0)	10.60 (270.0)	7.67 (195.0)	0.35 (9.0)	0.27 (7.0)	2.56 (65.0)	1.77 (45.0)	1.97 (50.0)	0.43 (13.0)	0.20 (5.0)	2.08 (53.0)	10.20 (260.0)	0.80 (20.0)	

Switching Devices

R9 Series (UL 98) Non-Fusible 100–1200A

Approximate Dimensions in Inches (mm)

Front Operation—F- and G-Frames

R9 Series Non-Fusible 600A

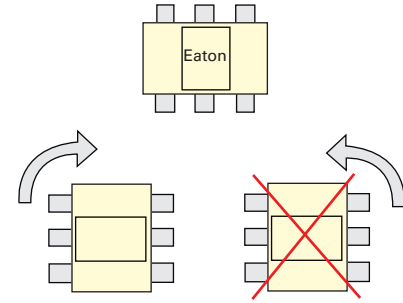
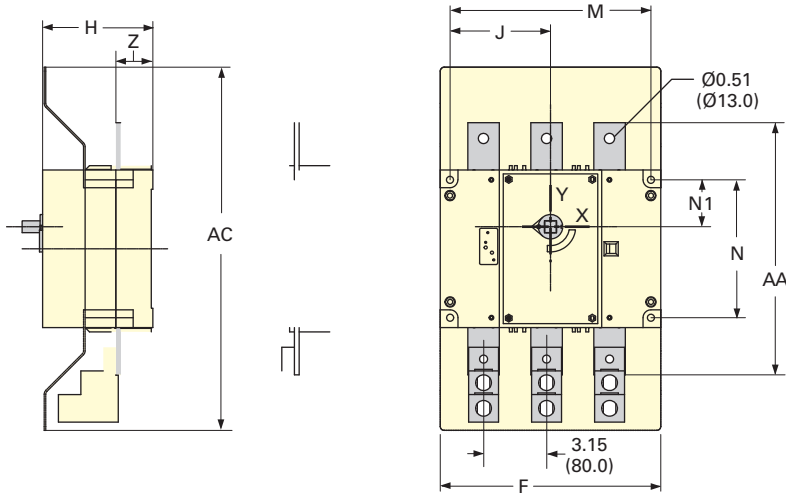

The switch will operate correctly when rotated clockwise 90 degrees.

The switch will not operate correctly when rotated counterclockwise 90 degrees.

Terminal Screens		Switch Body				Switch Mounting			Connection Terminals		
AC	F 3P	F 4P	H	J 2P	J 4P	M 4P	M 4P	N	N1	AA	Z
18.11 (460.0)	11.02 (280.0)	14.17 (360.0)	5.51 (140.0)	5.00 (127.5)	6.59 (167.5)	10.03 (255.0)	13.19 (335.0)	6.89 (175.0)	2.34 (59.5)	12.6 (320.0)	1.85 (47.0)

R9 Series Non-Fusible 800–1200A

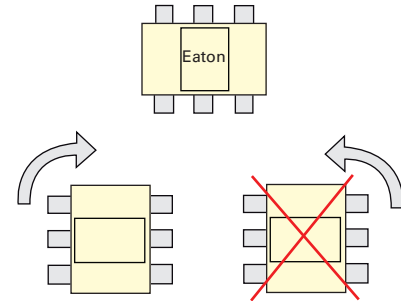
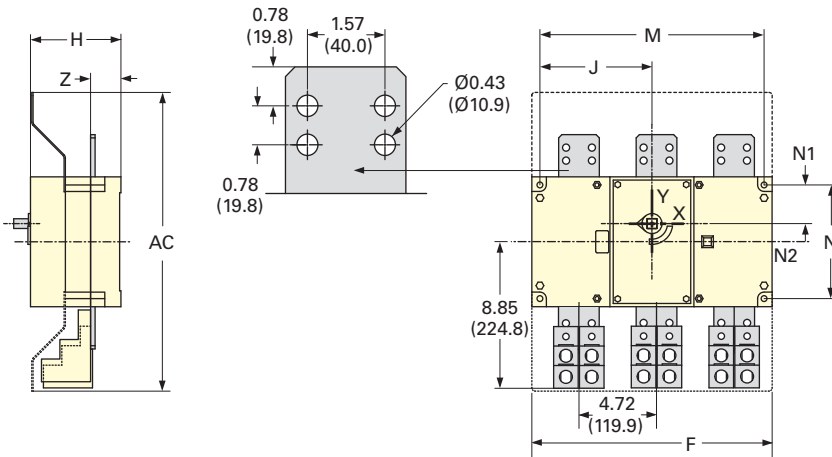

The switch will operate correctly when rotated clockwise 90 degrees.

The switch will not operate correctly when rotated counterclockwise 90 degrees.

Terminal Screens		Switch Body				Switch Mounting			Connection Terminals		
AC	F 3P	F 4P	H	J 3P	J 4P	M 3P	M 4P	N	N1	N2	Z
18.12 (460.0)	14.64 (372.0)	19.37 (492.0)	5.51 (140.0)	6.83 (173.5)	9.19 (233.5)	13.66 (347.0)	18.38 (467.0)	6.89 (175.0)	2.34 (59.5)	1.10 (28.0)	1.85 (47.0)

Approximate Dimensions in Inches (mm)

Direct Handle—Front Operation

R9 Series Non-Fusible 400A

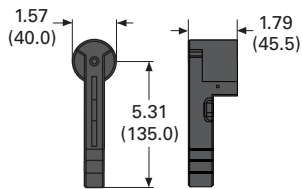

R9 Series Non-Fusible 600–1200A

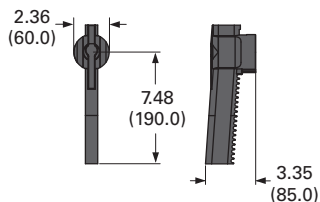

Door Interlocked External Handle

PH2 Type Handle

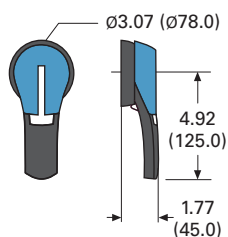

PH3 Type Handle

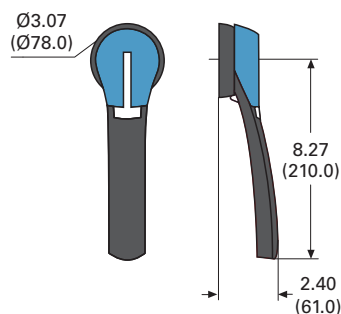

PH4 Type Handle

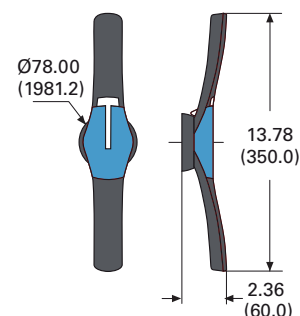

Direction of Operation

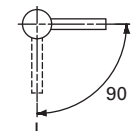
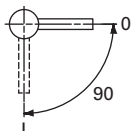
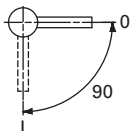

Door Drilling Templates

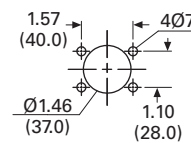
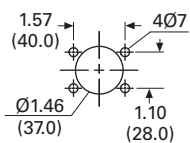
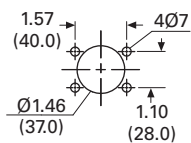

Top and Bottom Terminal Lugs

R9 Series Non-Fusible 100–200A

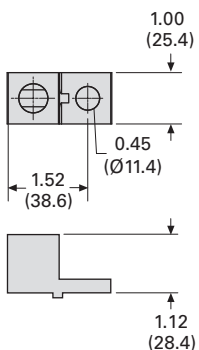

R9 Series Non-Fusible 400A

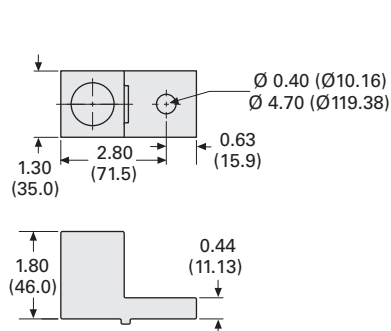

R9 Series Non-Fusible 600–1200A

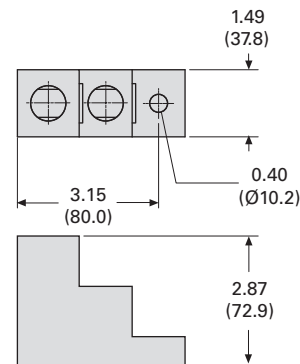

Switching Devices

R9 Series (UL 98) Fusible 30–800A



Contents

Description	Page
Product Overview	28
Features, Benefits, and Functions	28
Standards and Certifications	28
Illustrations	29
Product Selection	30
Accessories	34
Technical Data and Specifications	39
Dimensions	41

Product Overview

R9 Series (UL® 98 listed) Fusible 30–800A manual operated multi-pole fusible disconnect switches use double break contacts per pole that ensure complete isolation of the fuse when the switch is in the OFF position.

When installed with fuses, they provide protection for low voltage electrical installations against short circuit and overload.

Features, Benefits and Functions

- Load break functionality
- Double break contacts
- Up to 200 kA short-circuit rating with Class CC, J or L fuses
- Compact footprints
- The optional TEST position function (up to 400A) enables testing of the control circuit auxiliaries without switching the main contacts. This function provides a simple alternative to a separately wired pushbutton
- Defeatable pistol handles automatically re-latch when the panel door is closed
- Front or side operation
- Flange operation
- NFPA® 79 compliant kits
- Two-, three- and four-pole devices

Standards and Certifications

- UL 98, File E222859 for 30 to 800A ratings
- UL 489, File E305341 for H-Frame switches
- CSA® 22.2 No. 4, File 217736
- CSA 22.2 No. 5, File 217736, H-Frame only
- IEC 60947-1, EN 60947-1
- IEC 60947-3, EN 60947-3
- CE mark
- NFPA 79



Illustrations

R9 Fusible 30A/CC and 30A/J H-Frame—Direct and External Operation

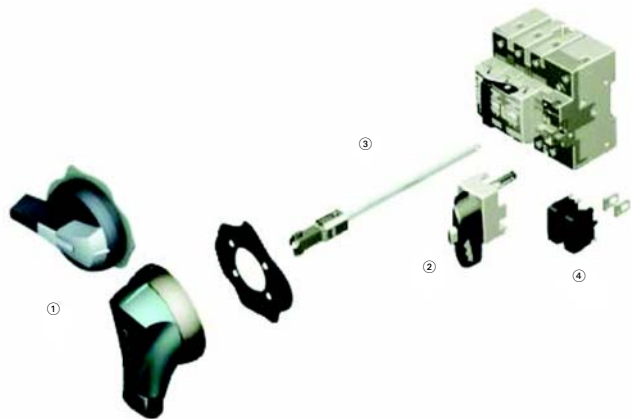

- ① External front handles
- ② Direct handle
- ③ Shaft extensions for external handles
- ④ Configurable U Type ACs, for pre-break and signaling or TEST

R9 Fusible 30A/J-800A/L (I-N-Frames)—Direct and External Operation

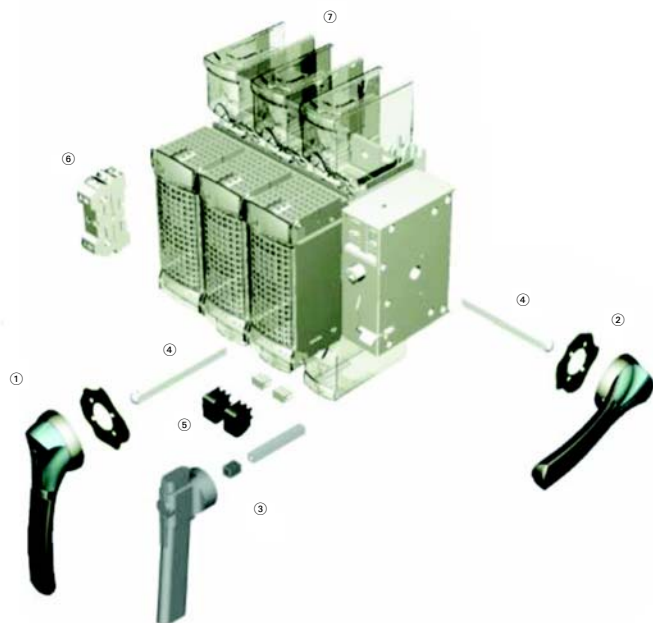

- ① External front handle
- ② External right side handle (not applicable for N-Frame 600/800A)
- ③ Direct handle
- ④ Shaft extensions for external handles
- ⑤ Configurable U Type ACs, for pre-break and signaling or TEST
- ⑥ Side auxiliary contacts
- ⑦ Terminal shrouds

Switching Devices

R9 Series (UL 98) Fusible 30–800A

Product Selection

Direct Operation



Switch body + Direct handle

External Operation

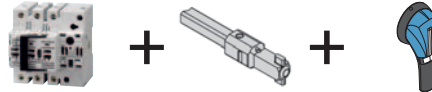

Switch body + Shaft + External handle

Front and Right Side Operation

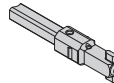

Ampere Rating (Frame) (Fuse Class)	Number of Poles	Switch Body Only	Direct Handle	External Selector Handle (Choose one)	Shaft Extension for Selector Handle Only (Choose one)	External Front Pistol Handle	External Right Side Pistol Handle
30 ① Compact (H-Frame) (CC)	3	R4H3030FCC	DHR9HC	Black 1,3R,12 SHB0N12HV	7.90 (200.0) SF200SH5X5H	Black 1,3R,12 PHB1N12F	—
30 ① (H-Frame) (CC)	3 + switched neutral	R4H3030FCCSN		Red 1,3R,12 SHR0N12HV	12.60 (320.0) SF320SH5X5H	Red 1,3R,12 PHR1N12F	
30 ① Compact (H-Frame) (J)	3	R4H3030FJ	DHR9HJ	Black 4,4X SHB0N4XHV	15.70 (400.0) SF400SH5X5H	Black 4,4X PHB1N4XF	
30 ① (H-Frame) (J)	3 + switched neutral	R4H3030FJSN		Red 4,4X SHR0N4XHV		Red 4,4X PHR1N4XF	
30 (I-Frame) (CC)	3 4	R9I3030FCC R9I4030FCC	DHR9J2M	—	—		
30 (J-Frame) (J)	2 3 4	R9J2030FJ R9J3030FJ R9J4030FJ				Black 4,4X (w/ TEST Position) PHB1N4XFT	Black 4, 4X PHB1N4XS
60 ① (J-Frame) (J)	2 3 4	R9J2060FJ R9J3060FJ R9J4060FJ				Red 4,4X (w/ TEST Position) PHR1N4XFT	Red 4, 4X PHR1N4XS

Note

① 100 kA short-circuit rating.

Front and Right Side Operation, continued

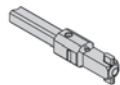

**Shaft Extensions for
Pistol Handle Only
In (mm)
(Choose one)**

**NFPA79
Kit**

**Auxiliary
Contacts
(Choose one)**

**S Type Auxiliary
Contacts
(Choose one)**

**Terminal
Shrouds**

7.90 (200.0)
SF200PH5X5

NFPA79H

1 AC
NO
AC1NOR9

—

Integral to switch

12.60 (320.0)
SF320PH5X5

15.70 (400.0)
SF400PH5X5

1 AC
NC
AC1NCR

7.90 (200.0)
SF200PH10X10

NFPA79JKL

1 AC
NO + NC
AC1N01NCJ2N

12.60 (320.0)
SF320PH10X10

15.70 (400.0)
SF400PH10X10

2 AC
NO + NC
AC2N02NCJ2N

19.70 (500.0)
SF500PH10X10

1 AC
NO + NC
w/ TEST
AC1N01NCJ2NT

2 AC
NO + NC
w/ TEST
AC2N02NCJ2NT

Switching Devices

R9 Series (UL 98) Fusible 30–800A

Front and Right Side Operation, continued



Ampere Rating (Frame) (Fuse Class)	Number of Poles	Switch Body Only	Direct Handle (Black)	External Front Pistol Handle (Choose one)	External Right Side Pistol Handle (Choose one)
60 ① (K-Frame) (J)	2	R9K2060FJ	DHR9J2M	Black 1,3R,12 PHB2N12F	Black 4, 4X PHB2N4XS
	3	R9K3060FJ		Red 1,3R,12 PHR2N12F	Red 4, 4X PHR2N4XS
	4	R9K4060FJ		Black 4,4X PHB2N4XF	
100 (K-Frame) (J)	2	R9K2100FJ		Red 1,3R,12 PHR2N12F	Red 4, 4X PHR2N4XS
	3	R9K3100FJ		Black 4,4X PHB2N4XF	
	4	R9K4100FJ		Red 4,4X PHR2N4XF	
200 (L-Frame) (J)	2	R9L2200FJ		Black 4,4X PHB2N4XF	
	3	R9L3200FJ		Red 4,4X PHR2N4XF	
	4	R9L4200FJ		Black 4,4X (w/ TEST Position) PHB2N4XFT ②	
400 (M-Frame) (J)	3	R9M3400FJ		Red 4,4X (w/ TEST Position) PHR2N4XFT ②	
	4	R9M4400FJ		Black 4, 4X PHB3N4XF	
				Red 4,4X PHR3N4XF	
600 (N-Frame) (J)	2	R9N2600FJ	DHR9N	Black 4, 4X PHB3N4XF	
	3	R9N3600FJ		Red 4,4X PHR3N4XF	
	4	R9N4600FJ			
800 (N-Frame) (L)	2	R9N2800FL		Red 4,4X PHR3N4XF	
	3	R9N3800FL			
	4	R9N4800FL			

Notes

① 200 kA short-circuit rating.

② Requires test handle.

Front and Right Side Operation, continued

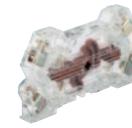
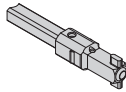

Ampere Rating (Frame) (Fuse Class)	Number of Poles	Switch Body Only	Shaft Extensions for External Handle In (mm) (Choose one)	NFPA79 Kit	Auxiliary Contacts (Choose one)	Auxiliary Contacts (Choose one)	Terminal Shrouds
60 ① (K-Frame) (J)	2	R9K2060FJ	7.90 (200.0)	NFPA79JKL	1 AC NO AC1NOR9	1 AC NO + NC AC1N01NCJ2N	Integral to switch
	3	R9K3060FJ	Pistol SF200PH10X10				
	4	R9K4060FJ					
100 (K-Frame) (J)	2	R9K2100FJ	12.60 (320.0)		1 AC NC AC1NCR9	2 AC NO + NC AC2NO2NCJ2N	
	3	R9K3100FJ	Pistol SF320PH10X10				
	4	R9K4100FJ	15.70 (400.0)				
200 (L-Frame) (J)	2	R9L2200FJ	Pistol SF400PH10X10			1 AC NO + NC w/ TEST AC1N01NCJ2NT ②	TSR9L2
	3	R9L3200FJ					TSR9L3
	4	R9L4200FJ	19.70 (500.0) Pistol SF500PH10X10				TSR9L4
400 (M-Frame) (J)	3	R9M3400FJ				2 AC NO + NC w/ TEST AC2NO2NCJ2NT ②	TSR9M3
	4	R9M4400FJ					TSR9M4
600 (N-Frame) (J)	2	R9N2600FJ	7.90 (200.0)	NFPA79N		1 AC NO + NC AC1N01NCJ2N	TSR9N2
	3	R9N3600FJ	Pistol SF200PH12X12				TSR9N3
	4	R9N4600FJ					TSR9N4
800 (N-Frame) (L)	2	R9N2800FL	12.60 (320.0) Pistol			2 AC NO + NC AC2NO2NCJ2N	TSR9N2
	3	R9N3800FL	SF320PH12X12				TSR9N3
	4	R9N4800FL	15.70 (400.0) Pistol				TSR9N4
			19.70 (500.0) Pistol SF500PH12X12				

Notes

- ① 200 kA short-circuit rating.
- ② Requires test handle.

Switching Devices

R9 Series (UL 98) Fusible 30–800A

Accessories

NFPA 79 Compliant



“Flange” Handle for Flange-Operated Switches

Description	Ampere Rating (Frame)	Handle Type	NEMA Type	Catalog Number
For side-operated switches only. Provides heavy-duty flange style operation. Meets both UL 508A and NFPA 79 requirements. Please order cable or rod link between handle and switch.	30–400 (J-, K-, L-, M-Frame)	Standard handle	1, 3, 3R, 4, 12	FHS ①
	30–400 (J-, K-, L-, M-Frame)	Chrome-plated handle	1, 3, 3R, 4, 4X, 12	FHCP ①



Cable Operator

Mechanism for Flange Handle



Description	Ampere Rating (Frame)	NEMA Type	Cable Length In (mm)	Catalog Number
Link between “Flange” handle and side-operated switches. Please order mechanism and “Flange” handle.	30–400 (J-, K-, L-, M-Frame)	Mechanism for “Flange” handle	—	CFM1
			36.00 (914.4)	CFC36
			60.00 (1524.0)	CFC60
			120.00 (3048.0)	CFC120



Rod Operator

Description	Ampere Rating (Frame)	For Enclosure Depth In (mm)	Catalog Number
Link between “Flange” handle and side-operated switches. Mechanism included. Please order “Flange” handle.	30–400 (J-, K-, L-, M-Frame)	8.00–24.00 (203.2–609.6)	RFM1

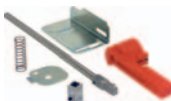

NFPA 79 “Through the Door” Kit

Description	Ampere Rating (Frame)	Catalog Number
For front-operated switches only. Meets both UL 508A and NFPA 79 requirements. Kit includes mechanism, shaft and internal handle. Please also order a “PH” type external pistol handle.	30 (H-Frame)	NFPA79H
	30–400 (J-, K-, L-, M-Frame)	NFPA79JKL
	600–800 (N-Frame)	NFPA79N

Note

① Defeatable.



Direct Handles

Description	Ampere Rating (Frame)	Fuse	Catalog Number
Front operation. Black.	30 (H-Frame)	CC	DHR9HC
	30 (H-Frame)	J	DHR9HJ
	30 (I-Frame)	CC	DHR9J2M
	30–400 (J-, K-, L-, M-Frame)	J	DHR9J2M
	600–800 (N-Frame)	J/L	DHR9N

S0 Type Handle



Door Interlocked External Front Handles

Description	Ampere Rating (Frame)	Handle Type	NEMA Type	Color	Standard Catalog Number
The handle locking function of the front external operation handle prevents the user from opening the door of the enclosure when the switch is in the ON position, and when the switch is padlocked in the OFF position (PH1, PH2 and PH3 type handles only). Opening the door when the switch is in the OFF position is possible by defeating the locking function with the use of a tool (authorized persons only). The locking function is restored when the door is closed back.	30 (H-Frame)	SO	1, 3R, 12	Black	SHB0N12HV
	30 (H-Frame)	SO	1, 3R, 12	Red/yellow	SHR0N12HV
	30 (H-Frame)	SO	4, 4X	Black	SHB0N4XHV
	30 (H-Frame)	SO	4, 4X	Red/yellow	SHR0N4XHV
	30–60 (H-, I-, J-Frame)	PH1	1, 3R, 12	Black	PHB1N12F
	30–60 (H-, I-, J-Frame)	PH1	1, 3R, 12	Red/yellow	PHR1N12F
	30–60 (H-, I-, J-Frame)	PH1	4, 4X	Black	PHB1N4XF
	30–60 (H-, I-, J-Frame)	PH1	4, 4X	Red/yellow	PHR1N4XF
	30–60 (H-, I-, J-Frame)	PH1	4, 4X	Black	PHB1N4XFT ①
	30–60 (H-, I-, J-Frame)	PH1	4, 4X	Red/yellow	PHR1N4XFT ①
	60–400 (K-, L-, M-Frame)	PH2	1, 3R, 12	Black	PHB2N12F
	60–400 (K-, L-, M-Frame)	PH2	1, 3R, 12	Red/yellow	PHR2N12F
	60–400 (K-, L-, M-Frame)	PH2	4, 4X	Black	PHB2N4XF
	60–400 (K-, L-, M-Frame)	PH2	4, 4X	Red/yellow	PHR2N4XF
	60–400 (K-, L-, M-Frame)	PH2	4, 4X	Black	PHB2N4XFT ①
	60–400 (K-, L-, M-Frame)	PH2	4, 4X	Red/yellow	PHR2N4XFT ①
	600–800 (N-Frame)	PH3	4, 4X	Black	PHB3N4XF
	600–800 (N-Frame)	PH3	4, 4X	Red/yellow	PHR3N4XF

PH1 Type Handle



PH2 Type Handle



PH3 Type Handle



Right Side External Handles

Ampere Rating (Frame)	Handle Type	NEMA Type	Color	Standard Catalog Number
30–60 (J-Frame)	PH1	4, 4X	Black	PHB1N4XS
30–60 (J-Frame)	PH1	4, 4X	Red/yellow	PHR1N4XS
60–400 (K-, L-, M-Frame)	PH2	4, 4X	Black	PHB2N4XS
60–400 (K-, L-, M-Frame)	PH2	4, 4X	Red/yellow	PHR2N4XS

Note

① Includes TEST position.

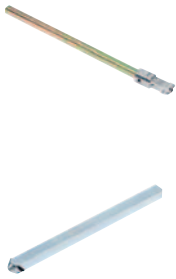

Shaft Extensions for External Handles

Ampere Rating (Frame)	Handle Type	Shaft Length In (mm)	Catalog Number
30 (H-Frame)	SH0	7.90 (200.0)	SF200SH5X5H
30 (H-Frame)	SH0	12.60 (320.0)	SF320SH5X5H
30 (H-Frame)	SH0	15.70 (400.0)	SF400SH5X5H
30 (H-Frame)	PH1	7.90 (200.0)	SF200PH5X5
30 (H-Frame)	PH1	12.60 (320.0)	SF320PH5X5
30 (H-Frame)	PH1	15.70 (400.0)	SF400PH5X5
30–400 (I-, J-, K-, L-, M-Frame)	PH2	7.90 (200.0)	SF200PH10X10
30–400 (I-, J-, K-, L-, M-Frame)	PH2	12.60 (320.0)	SF320PH10X10
30–400 (I-, J-, K-, L-, M-Frame)	PH2	15.70 (400.0)	SF400PH10X10
30–400 (I-, J-, K-, L-, M-Frame)	PH3	19.70 (500.0)	SF500PH10X10
600–800 (N-Frame)	PH3	7.90 (200.0)	SF200PH12X12
600–800 (N-Frame)	PH3	12.60 (320.0)	SF320PH12X12
600–800 (N-Frame)	PH3	15.70 (400.0)	SF400PH12X12
600–800 (N-Frame)	PH3	19.70 (500.0)	SF500PH12X12

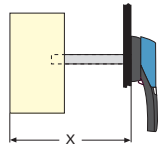

Handle Types SH and PH, X Minimum Dimensions

Ampere Rating (Frame)	Dimensions X In (mm)	Handle Type	Shaft Length In (mm)	Catalog Number
30 (H-Frame)	4.02–9.65 (102.0–245.0)	SH0	7.90 (200.0)	SF200SH5X5H
30 (H-Frame)	4.02–14.37 (102.0–365.0)	SH0	12.60 (320.0)	SF320SH5X5H
30 (H-Frame)	4.02–17.52 (102.0–445.0)	SH0	15.70 (400.0)	SF400SH5X5H
30 (H-Frame)	4.02–9.65 (102.0–245.0)	PH1	7.90 (200.0)	SF200PH5X5
30 (H-Frame)	4.02–14.37 (102.0–365.0)	PH1	12.60 (320.0)	SF320PH5X5
30 (H-Frame)	4.02–17.52 (102.0–445.0)	PH1	15.70 (400.0)	SF400PH5X5
30–100 (I-, J-, K-Frame)	5.30–9.06 (135.0–230.0)	PH2, PH3	7.90 (200.0)	SF200PH10X10
200 (L-Frame)	5.70–9.06 (145.0–230.0)	PH2, PH3	7.90 (200.0)	SF200PH10X10
400 (M-Frame)	7.87–10.24 (200.0–260.0)	PH2, PH3	7.90 (200.0)	SF200PH10X10
30–100A (I-, J-, K-Frame)	5.30–13.78 (135.0–350.0)	PH2, PH3	12.60 (320.0)	SF320PH10X10
200 (L-Frame)	5.70–13.78 (145.0–350.0)	PH2, PH3	12.60 (320.0)	SF320PH10X10
400 (M-Frame)	7.87–14.96 (200.0–380.0)	PH2, PH3	12.60 (320.0)	SF320PH10X10
30–100 (I-, J-, K-Frame)	5.30–16.93 (135.0–430.0)	PH2, PH3	15.70 (400.0)	SF400PH10X10
200 (L-Frame)	5.70–16.93 (145.0–430.0)	PH2, PH3	15.70 (400.0)	SF400PH10X10
400 (M-Frame)	7.87–18.10 (200.0–460.0)	PH2, PH3	15.70 (400.0)	SF400PH10X10
30–100 (I-, J-, K-Frame)	5.30–20.87 (135.0–530.0)	PH2, PH3	19.70 (500.0)	SF500PH10X10
200 (L-Frame)	5.70–20.87 (145.0–530.0)	PH2, PH3	19.70 (500.0)	SF500PH10X10
400 (M-Frame)	7.87–22.05 (200.0–560.0)	PH2, PH3	19.70 (500.0)	SF500PH10X10
600–800 (N-Frame)	10.63–11.97 (270.0–304.0)	PH3	12.60 (320.0)	SF320PH12X12
600–800 (N-Frame)	10.63–16.69 (270.0–424.0)	PH3	12.60 (320.0)	SF320PH12X12
600–800 (N-Frame)	10.63–19.84 (270.0–504.0)	PH3	15.70 (400.0)	SF400PH12X12
600–800 (N-Frame)	10.63–23.78 (270.0–604.0)	PH3	19.70 (50.00)	SF500PH12X12

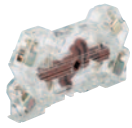

Auxiliary Contacts—NO + NC ①

Description	Ampere Rating (Frame)	Number of ACs	Operating Current I _g (Amperes)	
			Nominal Current (Amperes)	Catalog Number
For the R9 Series Fusible 30–800A, indication of the O and I positions by 1 to 4 NO + NC auxiliary contacts. Electrical principle: Cabling by terminal cage with #16 AWG maximum. High electrical characteristics: A600/D600	600–800 (N-Frame)	1NO + 1NC	10	AC1N01NCJ2N ②
	600–800 (N-Frame)	2NO + 2NC	10	AC2N02NCJ2N ②
	30–400 (I–M-Frame)	1NO + 1NC (w/ TEST)	10	AC1N01NCJ2NT
	30–400 (I–M-Frame)	2NO + 2NC (w/ TEST)	10	AC2N02NCJ2NT



Auxiliary Contacts—NO or NC ③

Description	Ampere Rating (Frame)	Number of ACs	Catalog Number
The different functions (pre-break, 0 and 1 indication, TEST feature) are easily configurable with pegs (one or two pegs per position). Two superposed auxiliary contacts maximum. For 30A/CC (H-Frame), maximum of four ACs. For 30A/J (H-Frame), maximum of two ACs. For 30 to 100A/J (I, J and K-Frame), maximum of four ACs. For 200 to 600A/J (L and M-Frame), maximum of eight ACs. Cabling to the control circuit by terminals with a maximum section of 2 x 2.5 mm ² . Electrical characteristics: A300	NO Auxiliary Contact		
	30–600 (H–M-Frame)	1	AC1N0R9
	NC Auxiliary Contact		
	30–600 (H–M-Frame)	1	AC1NCR9

Characteristics for Pre-Break Auxiliary Contacts

Ampere Rating	Contact Type	Nominal Current Amperes	Operating Current I _g (Amperes)			
			250 Vac AC-13	400 Vac AC-13	24 Vdc DC-13	48 Vdc DC-13
30–800	NO + NC	10	6	4	5	3

Terminal Shrouds



Terminal Shrouds

Description	Ampere Rating (Frame)	Number of Poles	Catalog Number
Line or load side protection against direct contact with terminals or the connection parts	30–100 (H-, I-, J-, K-Frame)	2/3/4	Integral to switch
	200 (L-Frame)	2	TSR9L2
	200 (L-Frame)	3	TSR9L3
	200 (L-Frame)	4	TSR9L3
	400 (M-Frame)	2	TSR9M2 ④
	400 (M-Frame)	3	TSR9M3 ④
	400 (M-Frame)	4	TSR9M4 ④
	600–800 (N-Frame)	2	TSR9N2
	600–800 (N-Frame)	3	TSR9N3
600–800 (N-Frame)	4	TSR9N4	

Notes

- ① Same-make/same-break auxiliary contacts.
- ② Auxiliary contacts without “Test” cannot be used on I–M-Frame switches.
- ③ Early-break/same-make auxiliary contacts.
- ④ For replacement only. Both line and load side terminal shrouds are included with 400A switch.

Switching Devices

R9 Series (UL 98) Fusible 30–800A



Line and Load Terminal Lugs

Description	Ampere Rating (Frame)	Fuse	Number of Lugs	Lug Capacity/Phase	Cable Type	Catalog Number
Connection of bare copper cables on to the terminals (no spade lugs).	30 (H-, I-Frame)	CC/J	—	#14–#10	Cu	Integral to switch
	30 (H-, I-Frame)	CC/J	—	#14–#10	Cu	Integral to switch
	30–60 (J-Frame)	J	—	#10–#6	Cu	Integral to switch
	60–100 (K-Frame)	J	—	#12–#1	Cu	Integral to switch
	200 (L-Frame)	J	2	#6–300 kcmil	Cu/Al	LK2R9DL
	200 (L-Frame)	J	3	#6–300 kcmil	Cu/Al	LK3R9DL
	200 (L-Frame)	J	4	#6–300 kcmil	Cu/Al	LK4R9DL
	400 (M-Frame)	J	3	(2) #2–600 kcmil	Cu/Al	LK3R9FN
	400 (M-Frame)	J	4	(2) #2–600 kcmil	Cu/Al	LK4R9FN
	600–800 (N-Frame)	J/L	2	(2) #2–600 kcmil	Cu/Al	LK2R9FN
	600–800 (N-Frame)	J/L	3	(2) #2–600 kcmil	Cu/Al	LK3R9FN
	600–800 (N-Frame)	J/L	4	(2) #2–600 kcmil	Cu/Al	LK4R9FN



Shorting Links

Ampere Rating (Frame)	Fuse	Pack Quantity	Catalog Number
60 (J-, K-Frame)	J	3	SLJK360
100 (K-Frame)	J	3	SLK3100
200 (L-Frame)	J	3	SLL3
400 (M-Frame)	J	3	SLM3
600–800 (N-Frame)	J/L	3	SLN3

Technical Data and Specifications

UL and CSA Characteristics

R9 Series Fusible 30–800A

Description	30A	30A	30A	30A	60A	60A	100A
General Use Ratings							
Switch Frame	H	H	I	J	J	K	K
600 Vac (A)	30	30	30	30	60	60	100
600 Vdc (A)	—	—	—	—	—	—	—
Short-Circuit Ratings							
Short-circuit rating at 600 Vac (kA)	100	100	100	200	100	200	200
Fuse type	CC	J	CC	J	J	J	J
Maximum fuse rating (A)	30	30	30	30	60	60	100
Maximum Horsepower Rating/Maximum Motor FLA Three-Phase							
220–240 Vac	7.5/22	7.5/22	7.5/22	7.5/22	15/42	15/42	30/80
440–480 Vac	15/21	15/21	15/21	15/21	30/40	30/40	60/77
600 Vac	20/22	20/22	20/22	20/22	50/52	50/52	75/77
Maximum Horsepower Rating/Maximum Motor FLA Single-Phase							
220–240 Vac	—	—	3/17	3/17	10/50	10/50	10/50
440–480 Vac	—	—	7.5/21	7.5/21	10/26	10/26	10/26
600 Vac	—	—	10/20	10/20	10/20	10/20	10/20
Maximum Horsepower Rating/Maximum Motor FLA DC							
125 Vdc ^①	3/25	3/25	3/25	3/25	5/40	5/40	7.5/58
250 Vdc ^②	5/20	5/20	5/20	5/20	10/38	10/38	20/72
Mechanical Characteristics							
Endurance (number of operating cycles)	10,000	10,000	10,000	10,000	10,000	10,000	10,000
Terminal Lugs							
Type	Integrated	Integrated	Integrated	Integrated	Integrated	Integrated	Integrated
Minimum conn. section	#14	#14	#14	#10	#10	#12	#12
Maximum conn. section	#10	#10	#10	#6	#6	#1	#1

Notes

- ① Two-pole in series.
- ② Three-pole in series.

Switching Devices

R9 Series (UL 98) Fusible 30–800A

R9 Series Fusible 30–800A, continued

Description	200A	400A	600A	800A
General Use Ratings				
Switch Frame	L	M	N	N
600 Vac (A)	200	400	600	800
600 Vdc (A)	—	—	600 ^②	800 ^②
Short-Circuit Ratings				
Short-circuit rating at 600 Vac (kA)	200	200	200	200
Fuse type	J	J	J	L
Maximum fuse rating (A)	200	400	600	800
Maximum Horsepower Rating/Maximum Motor FLA Single-Phase				
220–240 Vac	—	—	—	—
440–480 Vac	—	—	—	—
600 Vac	—	—	—	—
Maximum Horsepower Rating/Maximum Motor FLA Three-Phase				
220–240 Vac	60/154	125/312	200/480	200/480
440–480 Vac	125/156	250/302	500/590	500/590
600 Vac	150/144	350/336	500/472	500/472
Maximum Horsepower Rating/Maximum Motor FLA DC				
125 Vdc ^①	—	20/148	—	—
250 Vdc ^②	—	50/173 ^②	—	—
Mechanical Characteristics				
Endurance (number of operating cycles)	8000	6000	5000	5000
Terminal Lugs				
Type	Option	Option	Option	Option
Minimum conn. section	#6	#2	2x#2	2x#2
Maximum conn. section	3/0	300 kcmil	2 x 600 kcmil	2 x 600 kcmil

Notes

- ① Two-pole in series.
- ② Three-pole in series.

Dimensions

Approximate Dimensions in Inches (mm)

Front Operation

R9 Series Fusible 30A/CC—H-Frame

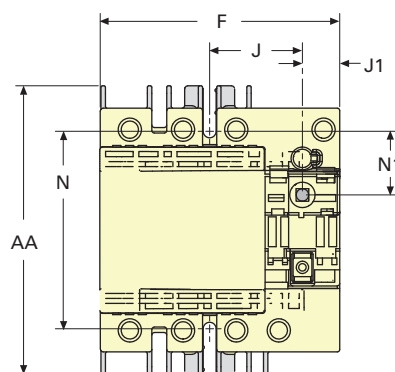
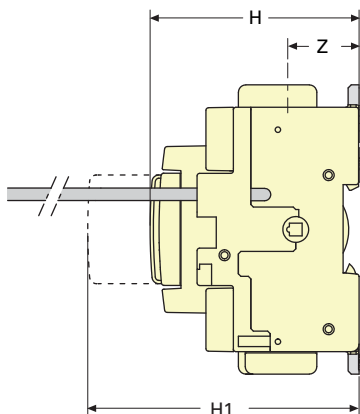

F	Switch Body		J	J1	Switch Mounting		Connection Terminals	
	H	H1			N	N1	AA	Z
3.78 (96.0)	3.28 (83.3)	5.19 (131.8)	1.47 (37.3)	0.59 (15.0)	3.13 (79.5)	1.00 (25.4)	4.56 (115.8)	1.12 (28.4)

R9 Series Fusible 30A/J—H-Frame

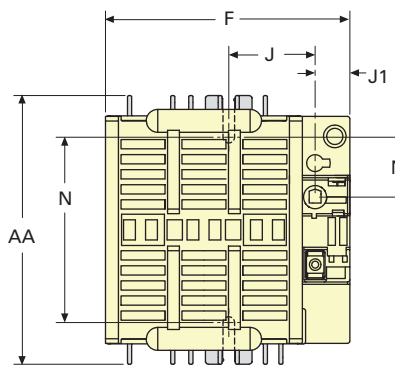
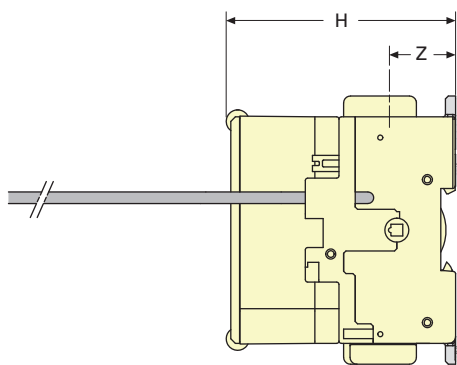

F	Switch Body		J1	Switch Mounting		Connection Terminals	
	H	J		N	N1	AA	Z
4.13 (104.9)	3.89 (98.8)	1.47 (37.3)	0.59 (15.0)	3.30 (83.8)	1.00 (25.4)	4.56 (115.8)	1.12 (28.4)

Switching Devices

R9 Series (UL 98) Fusible 30–800A

Approximate Dimensions in Inches (mm)

R9 Series Fusible 30A/CC—I-Frame

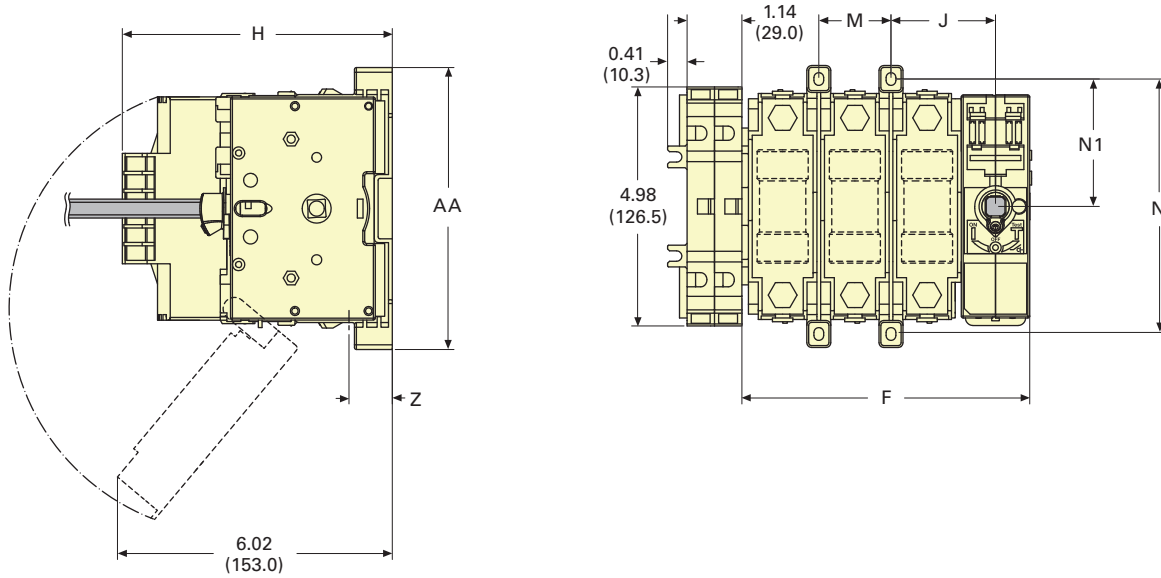

Ampere Rating (Fuse)	Switch body			Switch Mounting				Connection Terminals	
	F 3P	F 4P	H	J	M	N	N1	AA	Z
30 (CC)	4.92 (125.0)	6.06 (154.0)	3.89 (99.0)	1.77 (45.0)	1.14 (29.0)	5.31 (135.0)	2.63 (66.5)	5.87 (149.0)	1.21 (31.0)

R9 Series Fusible 30A/J and 60A/J (100 kA)—J-Frame

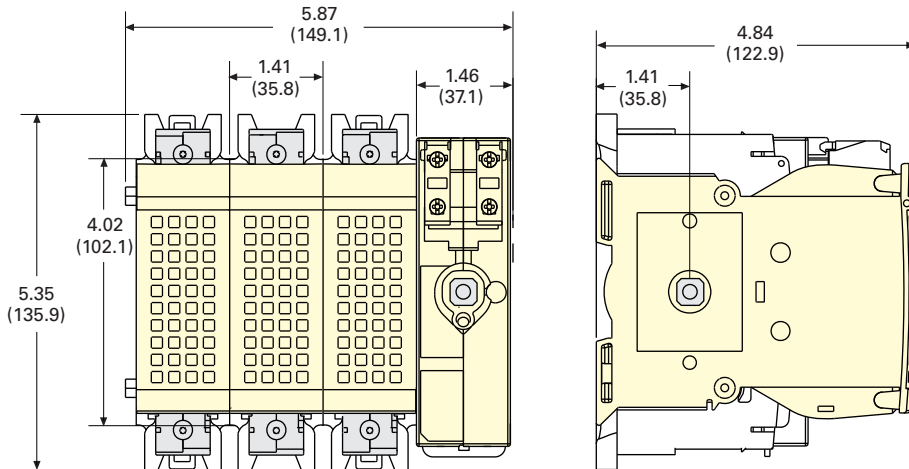

Approximate Dimensions in Inches (mm)

R9 Series Fusible 60A/J (200 kA) and 100A/J—K-Frame

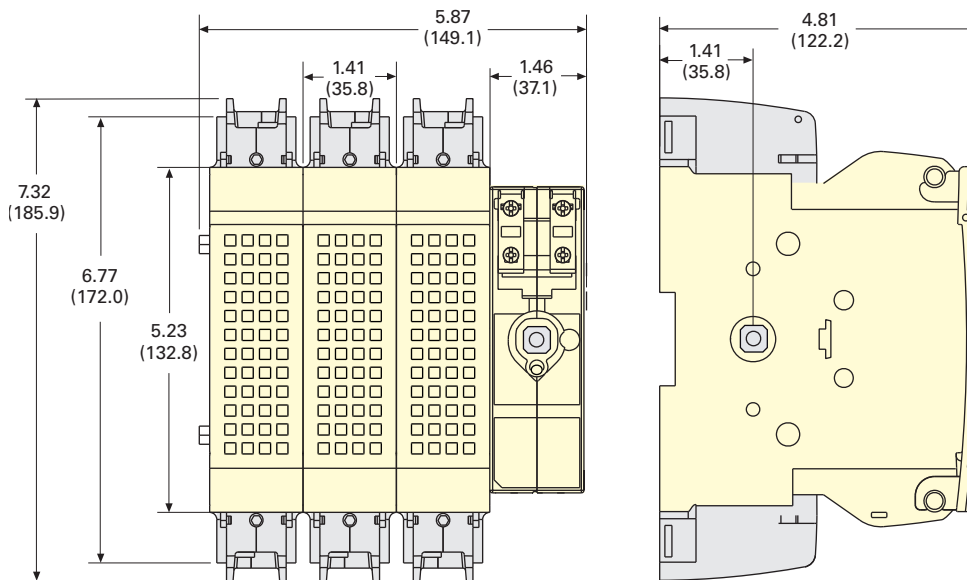

R9 Series Fusible 200A/J—L-Frame

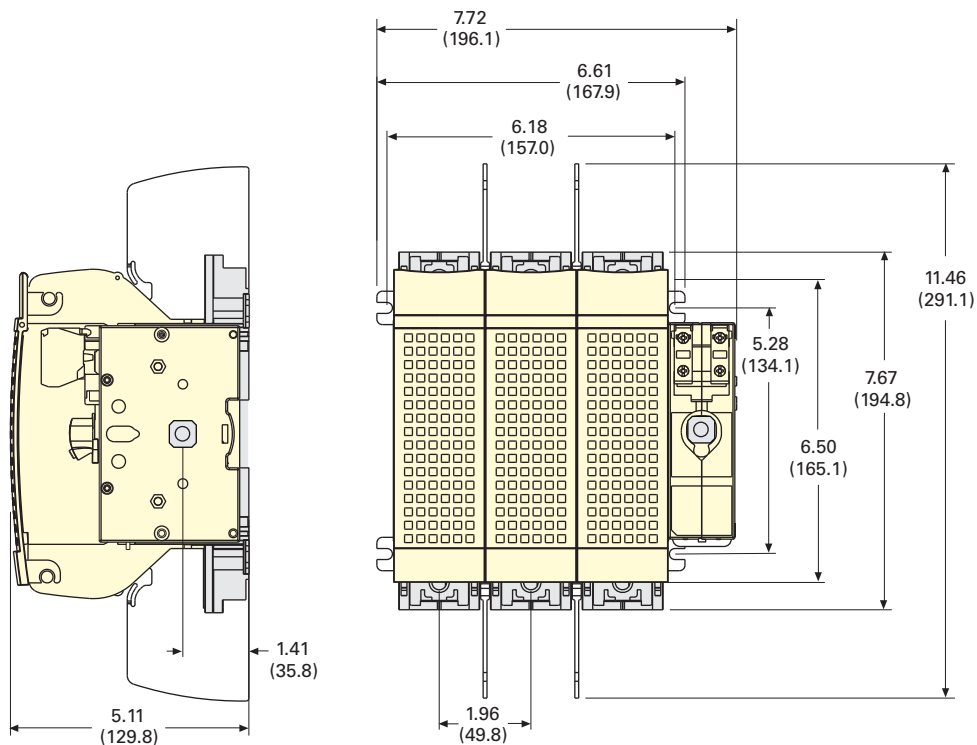

Switching Devices

R9 Series (UL 98) Fusible 30–800A

Approximate Dimensions in Inches (mm)

R9 Series Fusible 400A/J–M-Frame

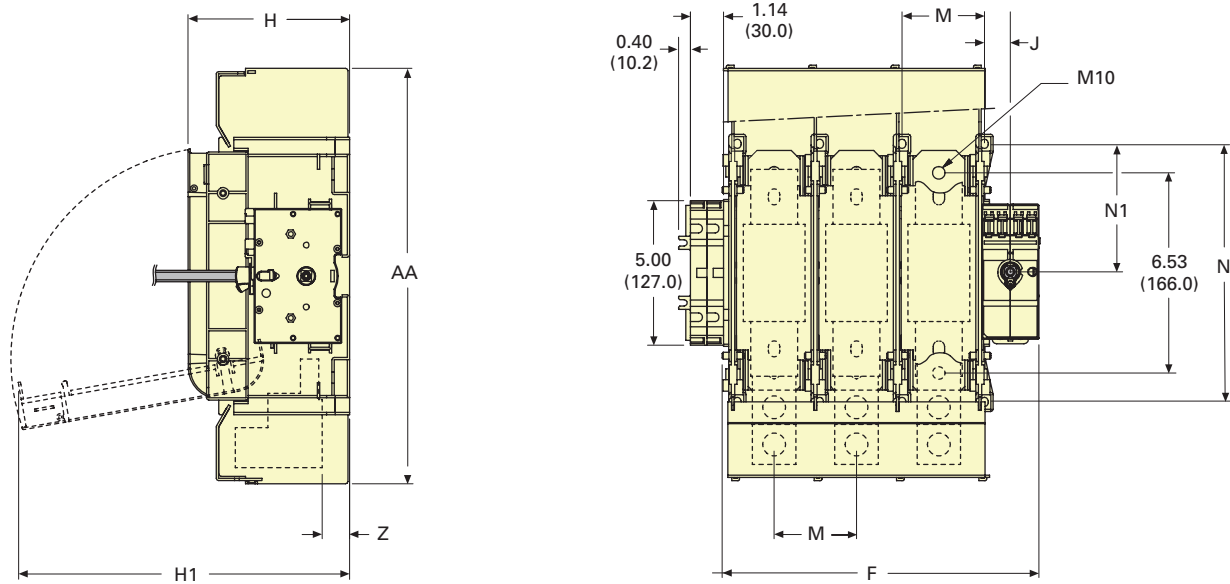

Switch Body				Switch Mounting				Connection Terminals	
F3P	F4P	H	H1	J	M	N	N1	AA	Z
10.80 (276.0)	13.70 (348.0)	5.56 (141.5)	11.41 (290.0)	0.88 (22.5)	2.84 (72.0)	8.83 (224.0)	4.41 (112.0)	14.31 (363.5)	1.06 (27.0)

R9 Series Fusible 600–800A J/L–N-Frame

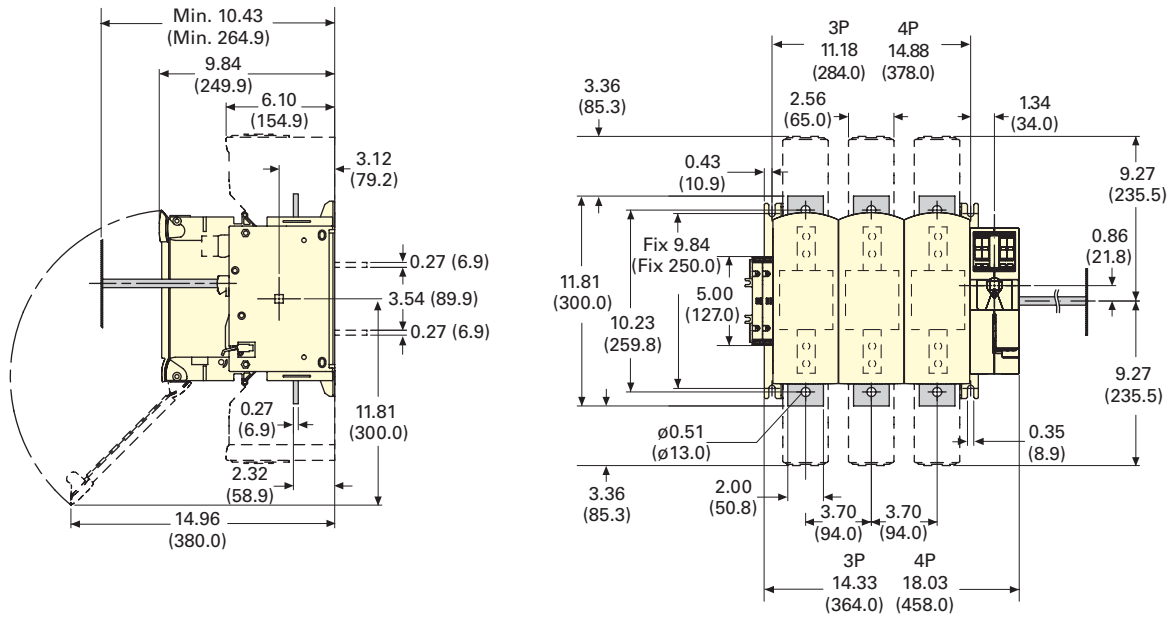

Approximate Dimensions in Inches (mm)

30CC (H-Frame)

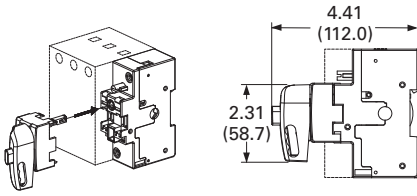

30J (H-Frame)

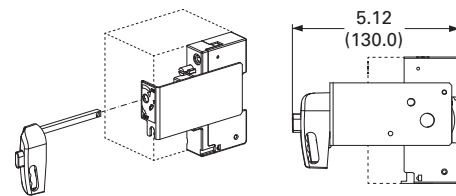

30J to 400J

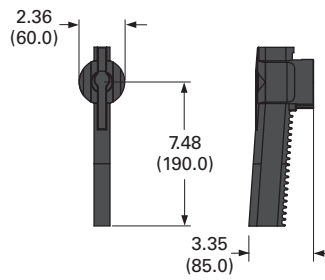

600J and 800L

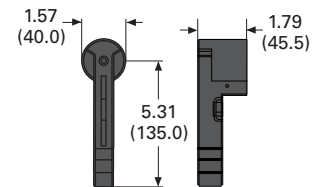

Flange Handle

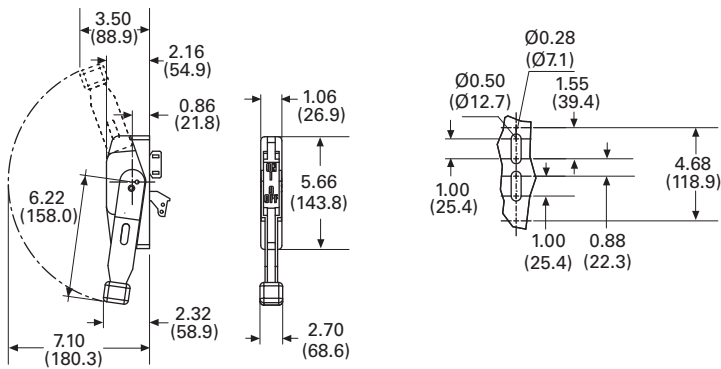

Switching Devices

R9 Series (UL 98) Fusible 30–800A

Approximate Dimensions in Inches (mm)

Door Interlocked External Handle

PH1 Type Handle

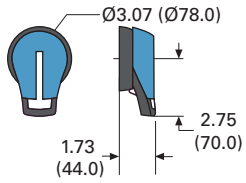

PH2 Type Handle

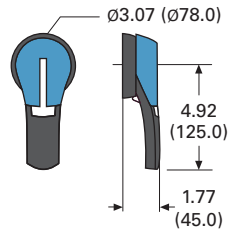

PH3 Type Handle

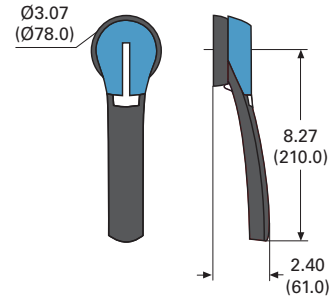

Direction of Operation

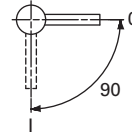
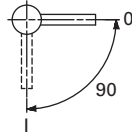
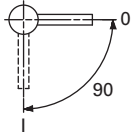

Door Drilling Template

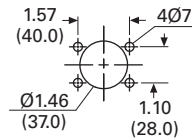
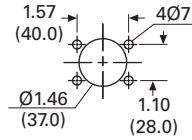
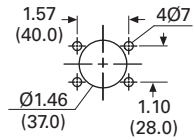

Line and Load Side Lugs

200A (L-Frame)

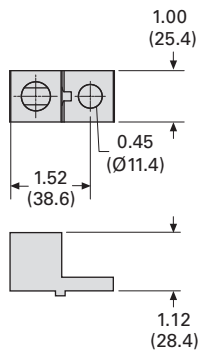

400–800A (M and N-Frames)

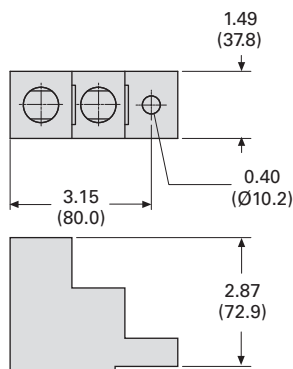



Contents

Description	Page
Product Overview	47
Features, Benefits and Functions	47
Application Description	47
Standards and Certifications	47
Product Selection	48
Accessories	49
Technical Data and Specifications	51
Dimensions	52

Product Overview

UL listed disconnect switches 600 Vdc for photovoltaic applications 100 to 400A

R9 Series (UL® 98 listed) DC rated disconnects are manually operated multi-pole load break switches. They provide safety isolation for any low voltage circuit in a photovoltaic application.

Features, Benefits and Functions

- Unique switching technology
- Up to 600 Vdc according to UL 98 / CSA®
- Up to 1000 Vdc according to IEC 947-3

Application Description

In three- and four-pole versions from 100 to 400A



Standards and Certifications

- UL 98, cULus®, File E222859
- CSA 22.2 No. 4, File 217736 ①
- IEC 60947-3
- EN 60947-3
- IEC 60-364-7-712 (Rules for the installations and sites special— photovoltaic applications)

① Q4 2010

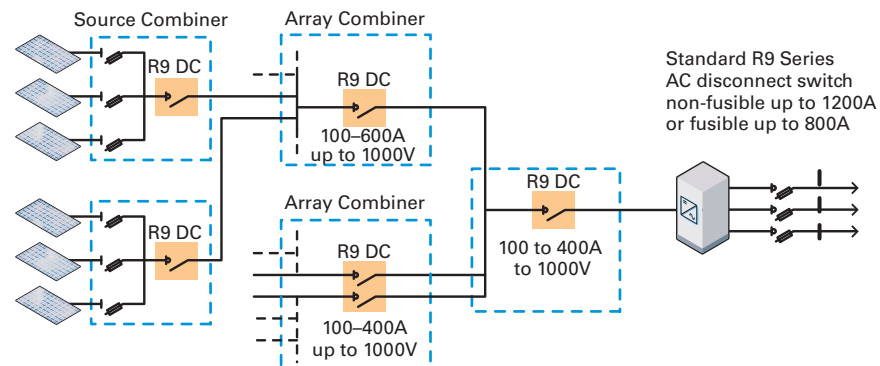

Simplified large photovoltaic system layout

Switching Devices

R9 Series (UL 98) DC Rated Disconnects

Product Selection

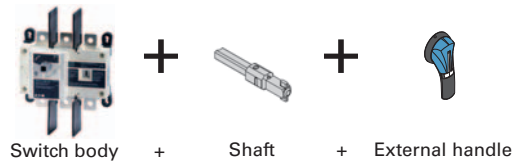
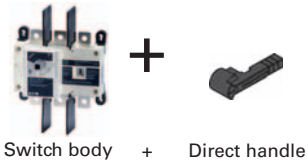

Front Operation—Three- and Four-Pole

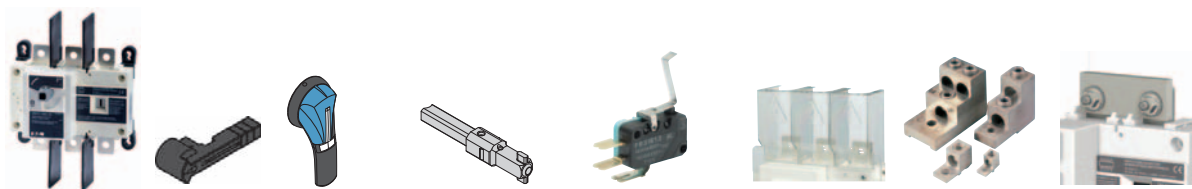

Ampere Rating	Number of Poles	Switch Body	Direct Handle	External Handle (Choose one)	Shaft for External Handle In (mm) (Choose one)	Auxiliary Contacts (Choose one)	Terminals Shroud	Terminal Lugs	Jumpers for Connecting Poles in Series
100	3	R9D3100UDC	DHR9DE	S2 Type	7.90 (200.0)	C Type	3P ②	3P ④	2 pieces
	4	R9D4100UDC		Black 1, 3R, 12 ①	SF200PH10X10	1st Contact NO+NC	TS3R9DT	LK3R9DL	DCJUMPD2
200	3	R9D3200UDC		PHB2N12F	12.60 (320.0)	AC1NONCDE	3P ③	4P ④	3 pieces
	4	R9D4200UDC		Red/Yellow 1, 3R, 12 ①	SF320PH10X10	2nd Contact NO+NC	TS3R9DB	LK4R9DL	DCJUMPD3
400	3	R9E3400UDC		Black 4, 4X ①	15.7 0 (400.0)	AC2NONCDE	4P ④		
	4	R9E4400UDC		PHB2N4XF	Red/Yellow 4, 4X ①	SF400PH10X10		TS4R9DTB	
							3P ②	3P ④	2 pieces
							TS3R9ET	LK3R9EM	DCJUMPE2
							3P ③	4P ④	3 pieces
							TS3R9EB	LK4R9EM	DCJUMPE3
							4P ④		
							TS4R9ETB		

Notes

- ① Defeatable handle.
- ② Top (line side).
- ③ Bottom (load side).
- ④ Top or bottom (line or load side).

Accessories

Direct Handle



Direct Handle

Description	Ampere Rating	Handle Color	Catalog Number
Front operation	100–400	Black	DHR9DE

PH2 Type Handle



Door Interlocked External Handle Front Operation—1-0, Three- and Four-Pole

Ampere Rating	Handle	Handle Color	NEMA Type	Catalog Number
100–400	PH2 Type	Black	1, 3R, 12	PHB2N12F ^①
100–400	PH2 Type	Red/yellow	1, 3R, 12	PHR2N12F ^①
100–400	PH2 Type	Black	4, 4X	PHB2N4XF ^①
100–400	PH2 Type	Red/yellow	4, 4X	PHR2N4XF ^①

Auxiliary Contacts



Description	Ampere Rating	Number of AC	Type	Catalog Number
Early-break/same-make and signaling of positions 0 and 1: 1 to 2NO/NC auxiliary contacts 1 to 2 low level NO/NC auxiliary contacts Characteristics: NO/NC AC: IP2 with front and side operation Connection to the control circuit: By 6.35 mm fast-on terminal Electrical Characteristics: 30,000 operations; A300	NO/NC Contact for Three and Four Poles			
	100–400	1 AC NO + NC	C Type	AC1NONCDE
	100–400	2 AC NO + NC	C Type	AC2NONCDE
	Low Level NO/ NC Contact for Three and Four Poles			
	100–400	1 AC NO + NC	C Type	AC1NONCDELL
	100–400	2 AC NO + NC	C Type	AC2NONCDELL

Terminal Screens



Description	Ampere Rating	Number of Poles	Position	Catalog Number
Line or load side protection against direct contact with terminals or connection parts	Three- and Four-Pole			
	100–200	3	Top (line)	TS3R9DT
	100–200	3	Bottom (load)	TS3R9DB
	100–200	4	Top or bottom (line or load)	TS4R9DTB
	400	3	Top (line)	TS3R9ET
	400	3	Bottom (load)	TS3R9EB
	400	4	Top or bottom (line or load)	TS4R9ETB

Note

^① Order two sets for line and load sides.

Switching Devices

R9 Series (UL 98) DC Rated Disconnects

Line and Load Terminal Lugs



Line and Load Terminal Lugs

Description	Ampere Rating	Connection Type	Number of Cables per Terminal	Lugs per Kit	Cable Type	Catalog Number
Connection of bare copper cables onto the terminals	100–200	6–300 kcmil	1	2	Cu/Al	LK2R9DL
	100–200	6–300 kcmil	1	4	Cu/Al	LK4R9DL
	400	2–600 kcmil	1	2	Cu/Al	LK2R9EM
	400	2–600 kcmil	1	4	Cu/Al	LK4R9EM

Jumpers for Connecting Poles in Series

Description	Ampere Rating	Kit of	Figure	Number of Poles in Series	Catalog Number
The jumpers will make easy the connection of the poles in series, allowing the following configurations: ①	100–200	2 Pieces	1	3	DCJUMP2
	100–200	3 Pieces	2	4	DCJUMP3
	400	2 Pieces	1	3	DCJUMPE2
	400	3 Pieces	2	4	DCJUMPE3

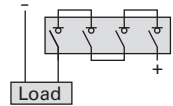
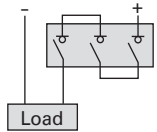

Shaft Extensions for External Front Dimensions (X)—Inches (mm)

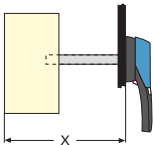
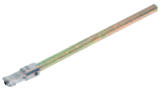

Description	Ampere Rating	Dimension X In (mm)	Handle	Shaft Length In (mm)	Catalog Number
Standard lengths: 7.9 inches/200 mm 12.6 inches/320 mm 15.7 inches/400 mm	For Three- and Four-Pole				
	100–400	135–265 (3429.0–6731.0)	PH2 Type	7.90 (200.0)	SF200PH10X10
	100–400	135–385 (3429.0–9779.0)	PH2 Type	12.60 (320.0)	SF320PH10X10
	100–400	135–465 (3429.0–11811.0)	PH2 Type	15.70 (400.0)	SF400PH10X10

Note

① For other connections, refer to installation instructions.

Technical Data and Specifications

100–400A

Characteristics According to UL 98

Thermal Current I_{th} at 40°C (A)		Ampere Rating		
		100	200	400
General Use Purpose Ampere Rating				
Rated voltage	In series	A	A	A
600 Vdc	3P	100	200	400
Overload Capacity				
Prospective short-circuit current (kA rms)		20	20	20
Type of fuse		A70P100	A70P200	LDC
Fuse rating		100	200	400
Connection Terminals				
Minimum connection section/AWG		#6	#6	#2
Maximum connection section/AWG		300 kcmil	300 kcmil	600 kcmil
Auxiliary Contacts				
Electrical characteristics		A300	A300	A300

Characteristics According to IEC 60947-3

Thermal Current I_{th} at 40°C (A)		Ampere Rating		
		160	250	630
Rated Operational Currents I_e (A), DC-22 B				
Rated voltage	In series	A	A	A
750 Vdc	3P	160	250	400
750 Vdc	4P	—	—	—
1000 Vdc	4P	160	250	400

Switching Devices

R9 Series (UL 98) DC Rated Disconnects

Dimensions

Approximate Dimensions in Inches (mm)

R9 Series DC Rated Disconnects 100–400A

Front Operation

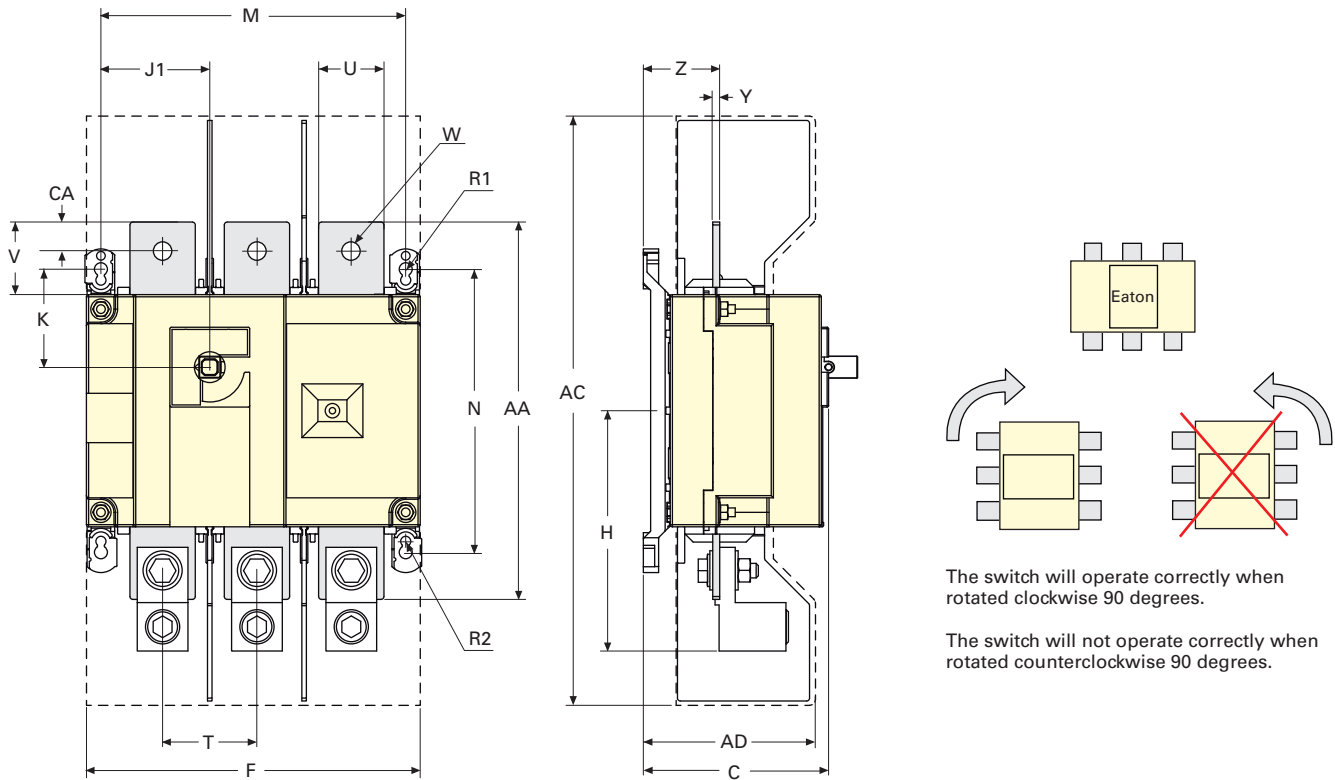

The switch will operate correctly when rotated clockwise 90 degrees.

The switch will not operate correctly when rotated counterclockwise 90 degrees.

R9 Series DC Rated Disconnects

Ampere Rating	C	AC	AD	F 3P	F 4P	H	J1 3P	J1 4P	K	M 3P	M 4P
100–200	3.72 (94.5)	10.10 (256.5)	3.05 (77.5)	7.09 (180.1)	9.06 (230.0)	4.22 (107.2)	2.17 (55.1)	4.13 (104.9)	1.80 (45.7)	6.30 (160.0)	8.27 (210.1)
400	4.92 (125.0)	16.00 (406.4)	4.51 (114.5)	9.05 (230.0)	11.40 (290.0)	6.53 (166.0)	2.95 (75.7)	5.31 (134.9)	2.65 (67.3)	8.26 (209.8)	10.60 (269.2)

Ampere Rating	N	R1	R2	T	U	V	W	Y	Z	AA	CA
100–200	5.31 (135.0)	0.35 (8.9)	0.27 (6.9)	1.97 (50.0)	0.98 (24.9)	1.18 (30.0)	0.43 (10.9)	0.14 (3.6)	1.35 (34.3)	6.30 (160.0)	0.60 (15.2)
400	7.60 (193.0)	0.35 (8.9)	0.27 (6.9)	2.56 (65.0)	1.77 (45.0)	1.97 (50.0)	0.43 (10.9)	0.20 (5.1)	2.08 (52.8)	10.20 (259.1)	0.80 (20.3)

Approximate Dimensions in Inches (mm)

Jumpers

100–200A

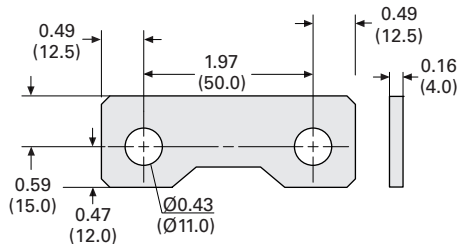

400A

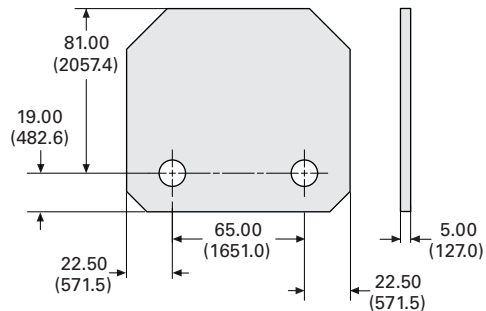

Terminal Lugs

100–200A

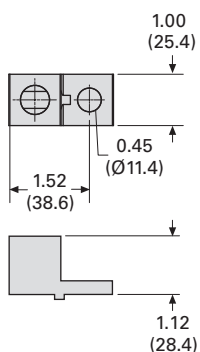

400A

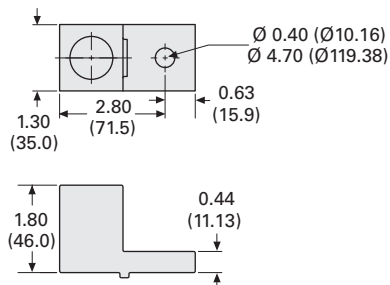

Switching Devices

R9 Series (UL 98) DC Rated Disconnects

Approximate Dimensions in Inches (mm)

Door Interlocked External Handle—100 to 400A, Three- and Four-Pole

PH2 Type Handle

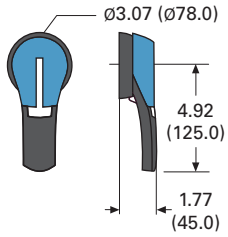

Direction of Operation

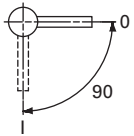

Door Drilling Template

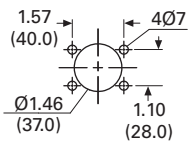

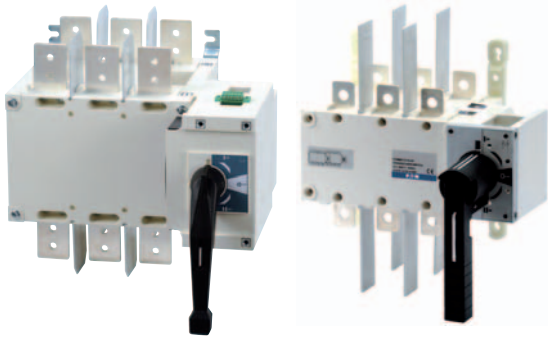

Contents

Description	Page
Product Overview	55
Standards and Certifications	55
Product Selection	56
Accessories	57
Technical Data and Specifications.	59
Dimensions	60

Product Overview

R9 Series (UL® 98 listed) non-fusible disconnects are heavy-duty manual transfer switches, they transfer load manually between two low voltage circuits and provide safety disconnection.

These switches are extremely durable and are tested and approved for use in the most demanding applications as resistive load or total system applications.

- Three load break positions (I, 0, II)
- On load switching
- Direct or external handle
- 480 Vac total system
- 600 Vac resistive load

Standards and Certifications

- UL 98, cULus®, File E222859
- UL 1008 (600–1200A)
- CSA® 22.2 No. 4, File 217736
- IEC 60947-3
- EN 60947-3
- CE

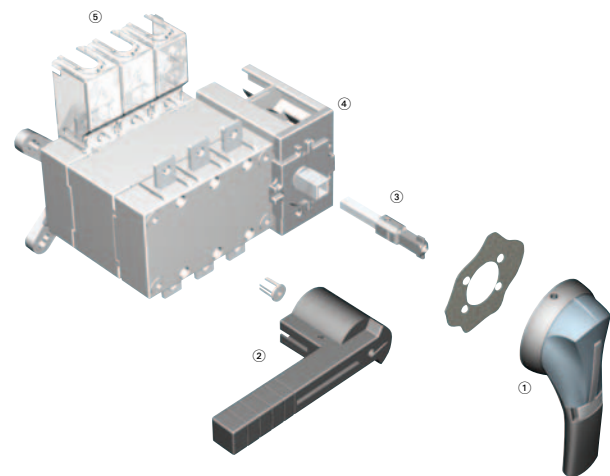

Overview

- ① External front handle
- ② Direct handle
- ③ Shaft extension for external handle
- ④ Pre-break ACs (standard on 600–1200A)
- ⑤ Terminal screen

Switching Devices

Manual Transfer/Double Throw Switches

Product Selection

Direct Operation



External Operation

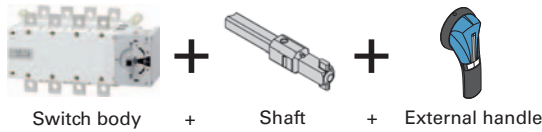

Manual Transfer/Double Throw Switches—UL 98 Standard ^①

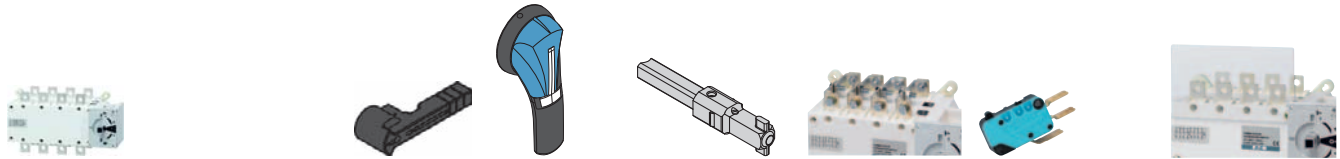

Ampere Rating	Number of Poles	Switch Body Only ^①	Direct Handle (Black)	External Three-Position Handle (Choose one)	Shaft Extensions for External Handle In (mm) (Choose one)	Bridging Bars	Auxiliary Contacts	Terminal Screens ^②
100	3	RMTS3100U	DHMTSSL	Size 2, Black I–O–II Type 4/4X PHB2N4X3P	7.90 (200.6) SF200PH10X10	3P BB3P200	NO/NC AC1NONCMTS400	3P TS3MTS200TB
	4	RMTS4100U						
200	3	RMTS3200U		Size 2, Red I–O–II Type 4/4X PHR2N4X3P	12.60 (320.0) SF320PH10X10	4P BB4P200	Low level AC1NONCMTS400LL ^③	4P TS4MTS200TB
	4	RMTS4200U						
400	3	RMTS3400U		Size 3, Black I–O–II Type 4/4X PHB3N4X3P	7.90 (200.6) SF200PH15X12	3P BB3P400		3P TS3MTS400TB
	4	RMTS4400U						
600	3	RMTS3600U	DHMTSDL	Size 4, Black I–O–II Type 4/4X PHB4N4X3P	12.60 (320.0) SF320PH15X12	4P BB4P600	NO/NC contact standard	4P TS4MTS600
	4	RMTS4600U						
800	3	RMTS3800U	DHMTSDLM	Size 4, Red I–O–II Type 4/4X PHR4N4X3P	15.70 (398.8) SF400PH15X12	3P BB3P1200		3P TS3MTS1200
	4	RMTS4800U						
1200	3	RMTS31200U				4P BB4P1200		4P TS4MTS1200
	4	RMTS41200U						

Notes

- ① All ratings, 100–1200A, are UL 98 listed; switches rated 600–1200A are also UL 1008 listed.
- ② Line or load (top or bottom); for both line and load, order two kits.
- ③ Low level auxiliary contact—gold plated for minimal resistance—for PLC applications.

Accessories



Direct Handle

Ampere Rating	Handle Color	Handle Type	Catalog Number
100–400	Black	Single lever	DHMTSSL
600	Black	Double lever	DHMTSDL
800–1200	Black	Double lever	DHMTSDLM

PH2 and PH3 Type



External Handle

Description	Ampere Rating	Handle Type	Handle Color	NEMA Type	Lockable in the "3" Positions	Catalog Number
The handle locking function prevents the user from opening the door of the enclosure when the switch is in the "ON" position. Opening the door when the switch is in the "ON" position is possible by defeating the locking function with the use of a tool (authorized persons only). The locking function is restored when the door is once again closed.	100–200	PH2	Black	4, 4X	Yes	PHB2N4X3P
	100–200	PH2	Red/Yellow	4, 4X	Yes	PHR2N4X3P
	400	PH3	Black	4, 4X	Yes	PHB3N4X3P
	400	PH3	Red/Yellow	4, 4X	Yes	PHR3N4X3P
	600–1200	PH4	Black	4, 4X	Yes	PHB4N4X3P
	600–1200	PH4	Red/Yellow	4, 4X	Yes	PHR4N4X3P

PH4 Type



Shaft Extension



Ampere Rating	Handle Type	Length In (mm)	Catalog Number
100–800	PH1	7.90 (200.6)	SF200PH10X10
125–800	PH1	12.60 (320.0)	SF320PH10X10
100–200	PH2	15.70 (398.8)	SF400PH10X10
630–1200	PH2, PH3	7.90 (200.6)	SF200PH15X12
600–1200	PH2, PH3	12.60 (320.0)	SF320PH15X12
400–1200	PH2, PH3	15.70 (398.8)	SF400PH15X12
800–1200	V1	12.60 (320.0)	SF320V1
800–1200	V1	15.70 (398.8)	SF400V1

Switching Devices

Manual Transfer/Double Throw Switches



Bridging Bars

Description	Ampere Rating	Number of Bridging Bars	Catalog Number
Creation of a common point, above or below the switch, between positions I and II.	100–200	3	BB3P200
	100–200	4	BB4P200
	400	3	BB3P400
	400	4	BB4P400
	600	3	BB3P600
	600	4	BB4P600
	800–1200	3	BB3P1200
	800–1200	4	BB4P1200



Terminals Protection Screen

Description	Ampere Rating	Number of Poles	Catalog Number
Top or bottom (line or load) protection against direct contacts with terminal or connecting parts.	100–200	3	TS3MTS200TB
	100–200	4	TS4MTS200TB
	400	3	TS3MTS400TB
	400	4	TS4MTS400TB
	600	6	TS3MTS600
	600	4	TS4MTS600
	800–1200	3	TS3MTS1200
	800–1200	4	TS4MTS1200



Mounting Spacers

Description	Ampere Rating	Number of Poles	Catalog Number
Raises the device's terminals 10 mm away from the bottom of the enclosure or frame on which the device is mounted.	100–400	1 set of 2 spacers	MSP400



Auxiliary Contacts

Description	Ampere Rating	Contact (s)	Catalog Number
Early-break/same-make and signalization per position 1 and 2. Electrical characteristics: A300.	100–400	1NO/NC per position 1 and 2	AC1NONCMTS400
	100–400	1NO/NC per position 1 and 2 low level	AC1NONCMTS400LL ①
	600–1200	1NO/NC per position 1 and 2	Standard



Line and Load Terminal Lugs

Description	Ampere Rating	Connection Type	Number of Poles	Number of Cables/Lug	Lugs per Kit	Cable Type	Catalog Number
Connection of bare copper cables onto the terminals (without spade lugs).	100–200	6–300 kcmil	3	1	3	Cu/Al	LK3R9DL
	100–200	6–300 kcmil	4	1	4	Cu/Al	LK4R9DL
	400	4–600 kcmil	3	1	3	Cu/Al	LK3R9EM
	400	4–600 kcmil	4	1	4	Cu/Al	LK4R9EM
	600	2x (#2–600 kcmil)	3	2	3	Cu/Al	LK3R9FN
	600	2x (#2–600 kcmil)	4	2	4	Cu/Al	LK4R9FN
	800–1200	2x (#2–600 kcmil)	3	2	6	Cu/Al	LK6R9G
	800–1200	2x (#2–600 kcmil)	4	2	8	Cu/Al	LK8R9G

Note

① Gold plated for minimal resistance—for PLC applications.

Technical Data and Specifications

UL 1008 Characteristics

Description	100A	200A	400A	600A	800A	1200A
Operation voltage	600	600	600	600	600	600
Short-circuit rating at 600 Vac (kA) ①	100	100	65	100	100	100
Type of fuse	J	J	J	L	L	L
Maximum fuse rating (A)	200	400	600	800	1000	1600
Short-circuit rating with circuit breaker (kA/ms)	10/25	10/25	14/50	35/50	35/50	35/50
Operational Power/Current Maximum Operational Three-Phase						
240 Vac total system (A)	100	100	250	400	700	700
240 Vac resistive load (A)	100	200	400	600	800	1200
480 Vac total system (A)	100	100	125	350	600	600
480 Vac resistive load (A)	100	200	400	600	800	1200
600 Vac resistive load (A)	100	200	400	400	800	1200
Mechanical Endurance						
Endurance (number of operating cycles)	6050	6050	6050	6050	3550	3550
Connection Terminals						
Minimum connection section/AWG	#6	#6	#4/2 x #6	2x #2	4x #2	4x #2
Maximum connection section/AWG	300 kcmil	300 kcmil	600 kcmil/2x 350 kcmil	2x 600 kcmil	4x 600 kcmil	4x 600 kcmil

UL 98/CSA 22.2 No. 4 Characteristics

Description	100A ②	200A ②	400A ②	600A	800A	1200A
Short-circuit rating at 600 Vac (kA)	200	200	200	200	100	100
Type of fuse	J	J	J	J	L	L
Maximum fuse rating (A)	100	200	400	600	800	1200
Maximum Motor, hp/FLA Three-Phase Motor Maximum						
220–240 Vac	30/80	75/192	125/312	200/480	200/480	200/480
440–480 Vac	75/96	180/180	250/302	400/477	500/590	500/590
600 Vac	100/99	200/192	350/336	350/336	500/472	500/472
Maximum Motor Power, hp/DC FLA Motor Maximum						
125 Vdc ③	7.5/58	15/112	20/148	20/148	—	—
250 Vdc ④	20/72	40/140	50/173	50/173	—	—
Mechanical Characteristics						
Endurance (number of operating cycles)	10,000	8000	6000	6000	3500	3500
Operating torque (lbs. in/Nm)	88.5/10	88.5/10	128.3/14.5	327.5/37	442.5/50	442.5/50
Auxiliary Contacts						
Electrical characteristics	A300	A300	A300	A300	A300	A300

Notes

- ① Short-circuit rating achieved when used with respective fuse type and maximum fuse rating.
- ② Only UL 98 listed. For UL 1008 availability, contact Eaton.
- ③ Two-pole in series.
- ④ Three-pole in series.

Switching Devices

Manual Transfer/Double Throw Switches

Dimensions

Approximate Dimensions in Inches (mm)

100 to 200A

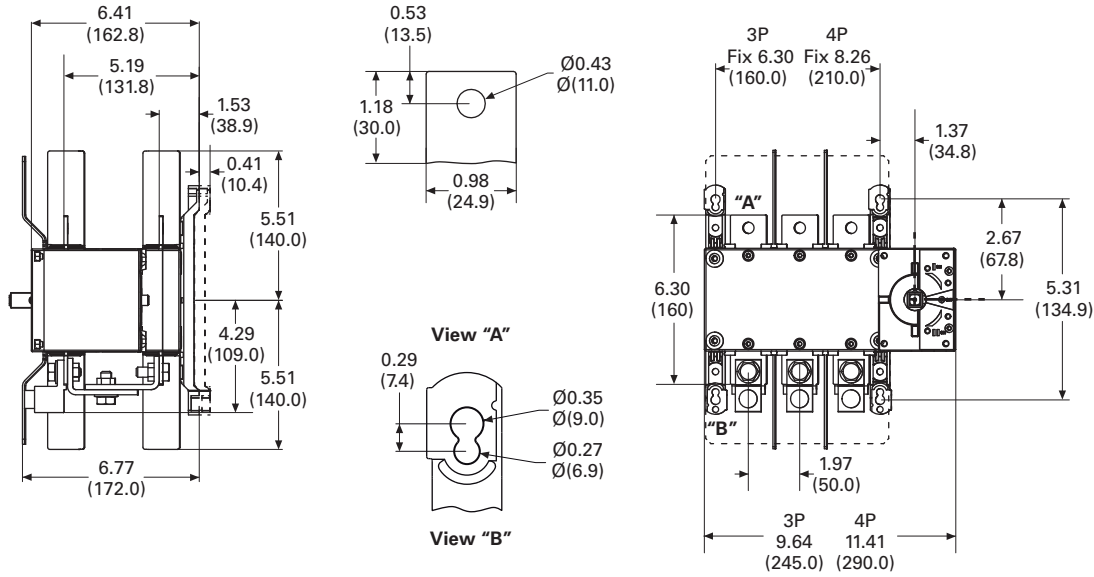

400A

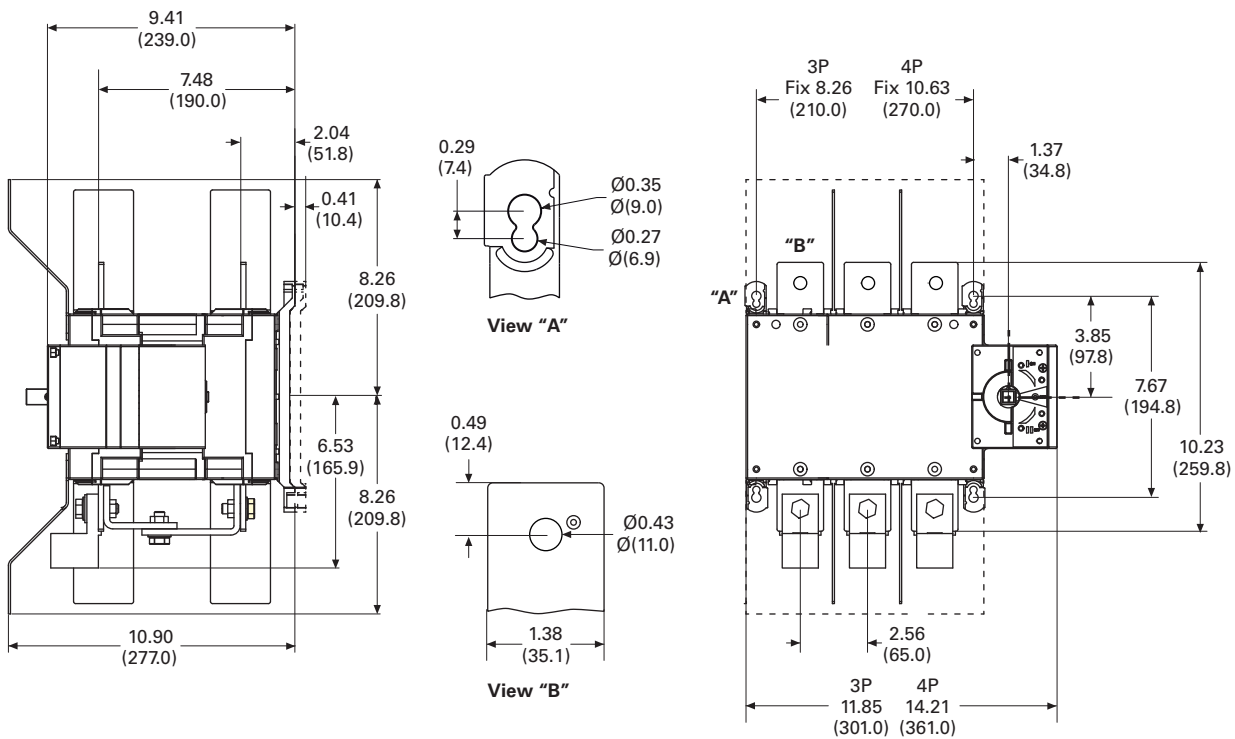

Approximate Dimensions in Inches (mm)

600A

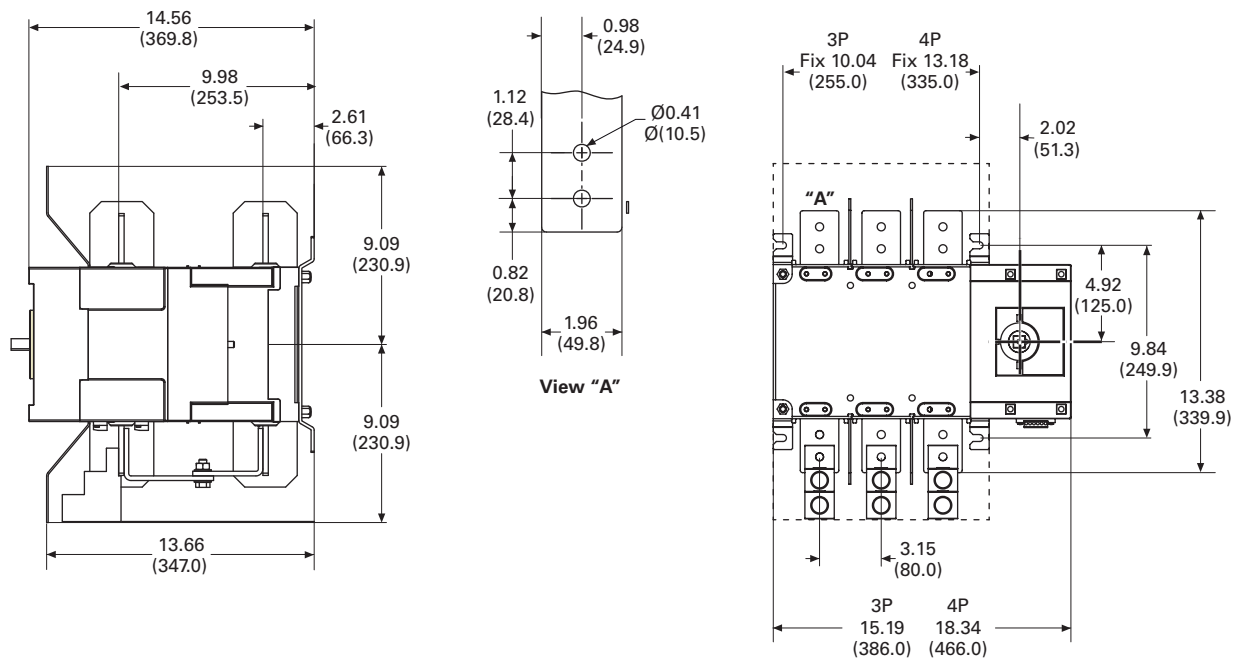

800 to 1200A

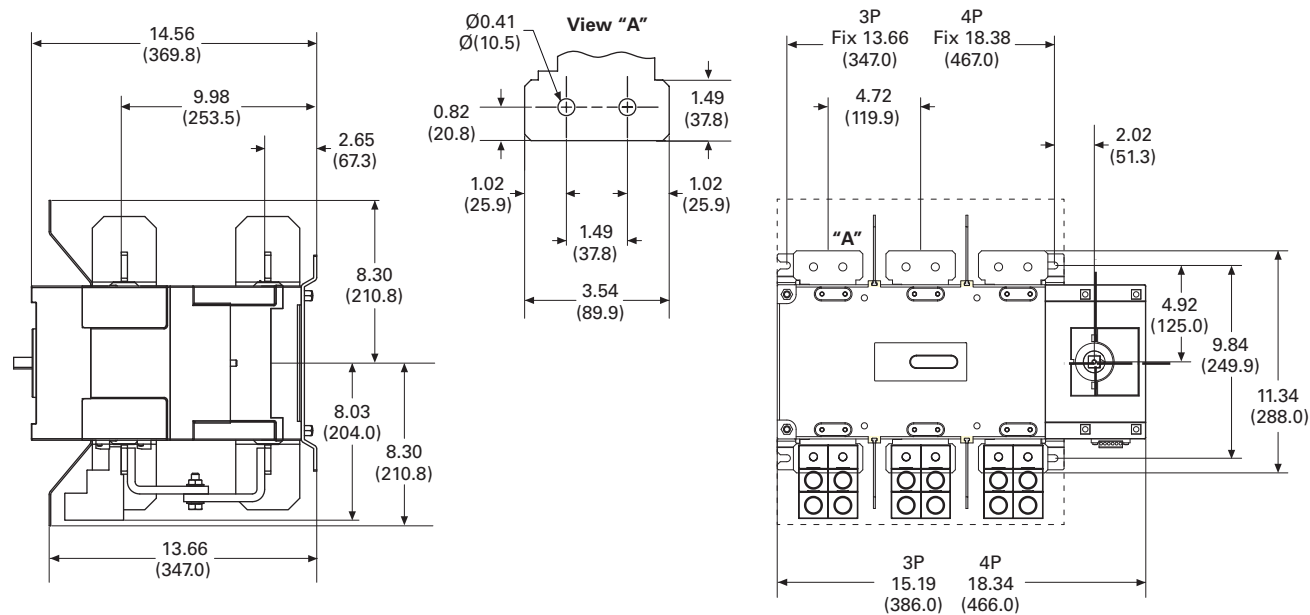

Switching Devices

Manual Transfer/Double Throw Switches

Approximate Dimensions in Inches (mm)

Terminal Lugs

100-200A

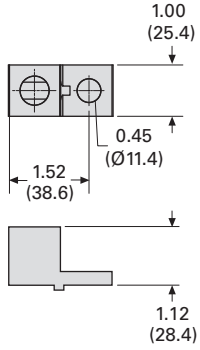

400A

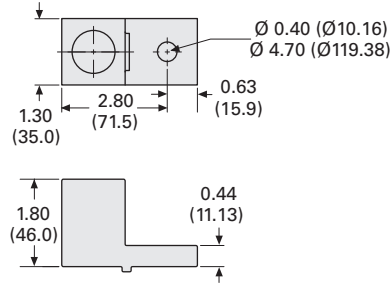

600-1200A

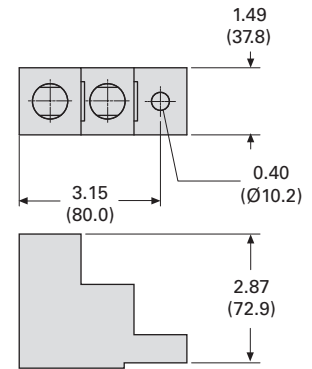

100-200A

PH2 Type

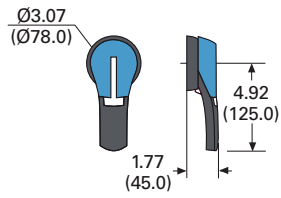

Direction of Operation

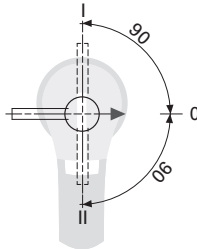

Door Drilling Template

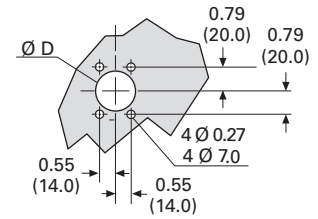

400A

PH3 Type

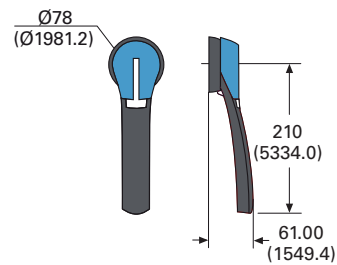

Direction of Operation

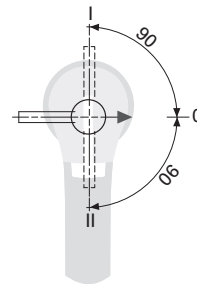

Door Drilling Template

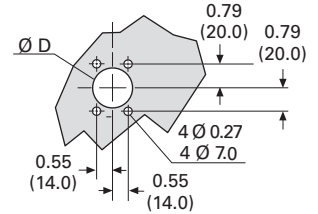

Approximate Dimensions in Inches (mm)

600-1200A

PH4 Type

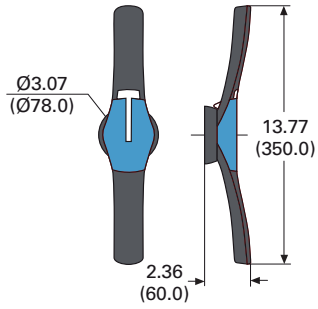

Direction of Operation

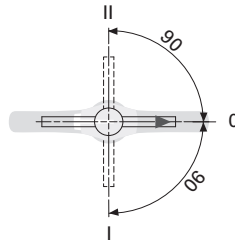

Door Drilling Template

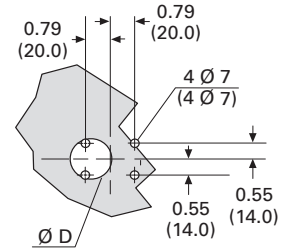

Enclosed Rotary Disconnects



Product Overview

Provide users with the ability to lock directly wired motor loads in the OFF position to comply with OSHA lockout/tagout regulations. Also for machine applications that require compact, economical disconnect switches.

Enclosed rotary disconnect switches allow safe control and safe disconnect of any motor application.

Features, Benefits and Functions

- Padlockable in the OFF position (up to three padlocks) to meet OSHA lockout requirements
- Available in 16–80A ratings
- 600 Vac, three- and four-pole non-fusible device
- Rated for making and breaking loads
- Accepts auxiliary contacts; capability to signal PLC controllers
- Ground lug connection provided
- Possibility of adding one power pole and one auxiliary contact
- NEMA® Type 1, 3R, 12, 4, 4X

Open rotary disconnects can be found in Volume 5, Motor Control and Protection Catalog CA08100006E.

Contents

Description

	Page
Product Overview	64
Features, Benefits and Functions	64
Standards and Certifications	64
Product Selection	65
Dimensions	66

Standards and Certifications

- Meets NEC® Article 430 requirements for a separate disconnect means within sight of all motor loads
- UL® listed under Section 508
- UL listed File No. E165150
- CSA® listed under 22.2 No. 14, File 162136



Product Selection

Enclosed Rotary Non-Fusible ^①

Ampere Rating	Maximum Horsepower Ratings				NEMA 1 ^② Enclosure Indoor Catalog Number	NEMA 12 ^{②③} Enclosure Dust-Tight/ Rainproof Catalog Number	NEMA 4X ^② Enclosure Corrosion-Resistant, Stainless Steel Catalog Number	NEMA 4X ^② Enclosure Corrosion-Resistant, Non-Metallic Catalog Number	NEMA 4X Enclosure Polycarbonate- Non-Metallic Catalog Number
	Three-Phase AC		480V	600V					
Three-Pole, 600 Vac									
16	3	5	10	10	ER53016UG	ER53016UD	ER53016UW	ER53016UX	—
25	7-1/2	7-1/2	15	20	ER53025UG	ER53025UD	ER53025UW	ER53025UX	—
30	7-1/2	7-1/2	15	20	ER53030UG	ER53030UD	ER53030UW	ER53030UX	ER53030UPGB ^{④⑤}
40	7-1/2	7-1/2	20	25	ER53040UG	ER53040UD	ER53040UW	ER53040UX	—
60	15	15	30	30	ER53060UG	ER53060UD	ER53060UW	ER53060UX	ER53060UPGB ^{④⑤}
80	15	20	40	40	ER53080UG	ER53080UD	ER53080UW	ER53080UX	—
Four-Pole, 600 Vac									
16	3	5	10	10	ER54016UG	ER54016UD	ER54016UW	ER54016UX	—
25	7-1/2	7-1/2	15	20	ER54025UG	ER54025UD	ER54025UW	ER54025UX	—
30	7-1/2	7-1/2	20	25	ER54030UG	ER54030UD	ER54030UW	ER54030UX	—
40	7-1/2	7-1/2	20	25	ER54040UG	ER54040UD	ER54040UW	ER54040UX	—

Accessories for Enclosed Rotary Disconnects ^{⑥⑦}

Disconnect Ampere Rating	Switched Fourth Pole	Unswitched Neutral Pole	Auxiliary Contacts (Choose one)	Terminal Shrouds
16	S4PR516	UNMR5A	1NO + 1NC AC1NONC	Single-pole TS1R5A
25	S4PR525			
30	S4PR530		2NC AC2NC	Three-pole TS3R5A
40	S4PR540			
60	S4PR560	UNMR5B		Single-pole TS1R5B
80	S4PR580			Three-pole TS3R5B

Notes

- ① Short-circuit current ratings are same as those listed in the table on Page 10, for the respective disconnect amperage.
- ② For CSA listed switches, add prefix letter "C" to the front of the catalog number.
- ③ NEMA Type 12 enclosures (16–80A) can be field modified to meet NEMA Type 3R rainproof requirements when a factory-provided drain hole is opened.
- ④ "GB" suffix = **G**ray cover, **B**lack handle; "GR" suffix = **G**ray cover, **R**ed handle; "YR" suffix = **Y**ellow cover, **R**ed handle.
- ⑤ cULus only.
- ⑥ Ordered and shipped as separate components—not integral to enclosed device.
- ⑦ Enclosed disconnects can accept one power pole, neutral or up to two auxiliary contacts (one mounted on either side of switch).
- Contact the Safety Switch Flex Center (1-888-329-9272) for factory-installed accessories or other special modifications.

Switching Devices

Enclosed Rotary Disconnects

Dimensions

Approximate Dimensions in Inches (mm)

NEMA Type 1 (16–40A)

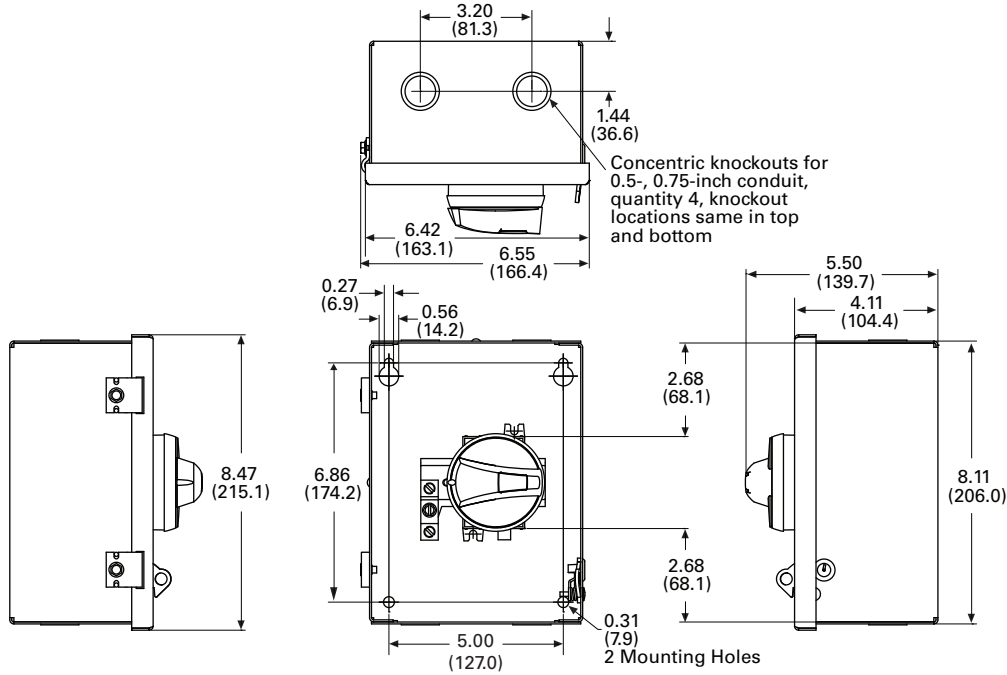

Note:

Wire range of switch lugs for 16–25A is #6–#10 copper, and for 30–40A is #8–#14. Wire range of ground lugs is #2–#14 copper or aluminum.

NEMA Type 1 (60–80A)

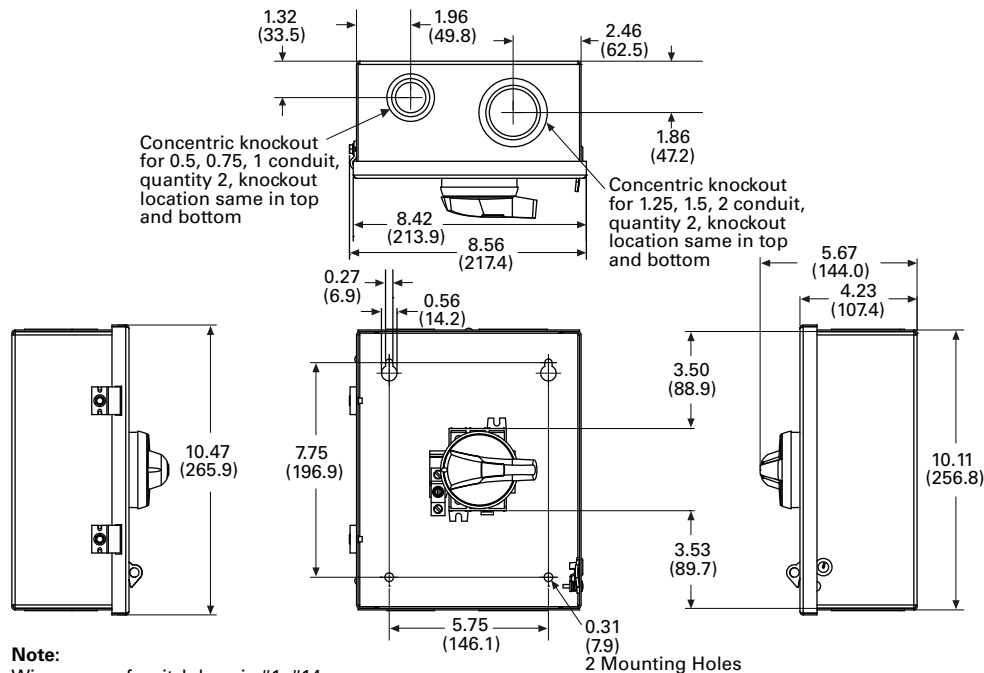

Note:

Wire range of switch lugs is #1–#14 copper. Wire range of ground lugs is #2–#14 copper or aluminum.

Approximate Dimensions in Inches (mm)

NEMA Type 12/3R (16–40A)

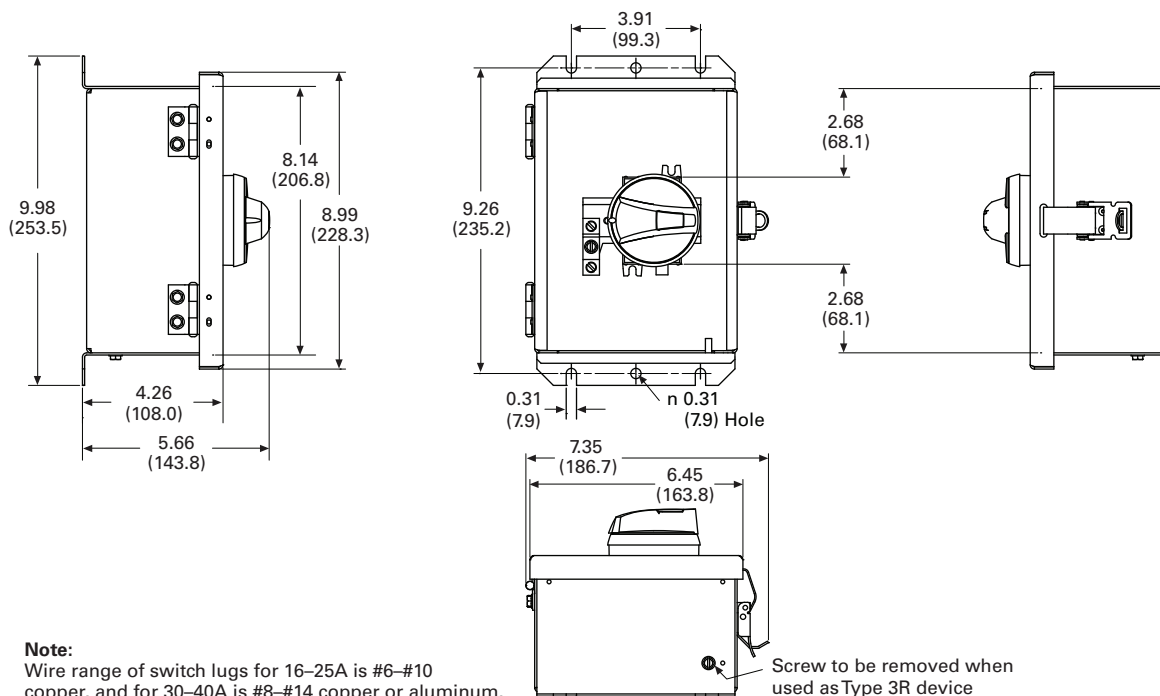

NEMA Type 12/3R (60–80A)

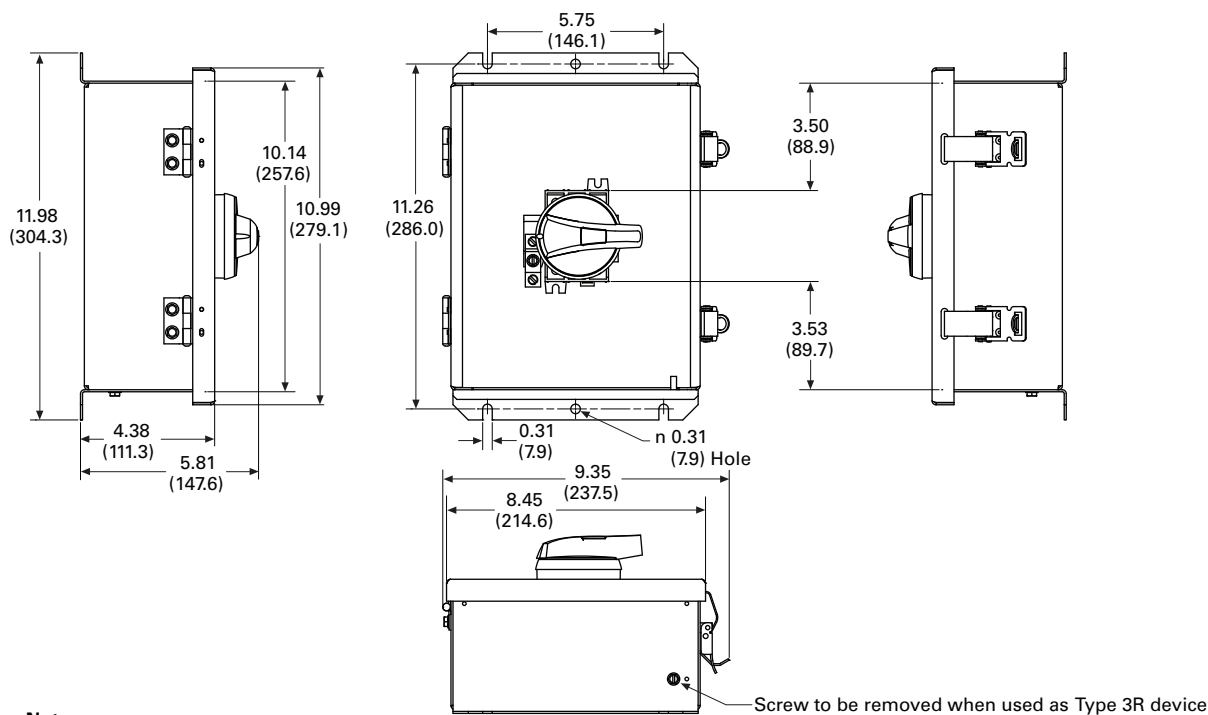

Switching Devices

Enclosed Rotary Disconnects

Approximate Dimensions in Inches (mm)

NEMA Type 4X Stainless (16–40A)

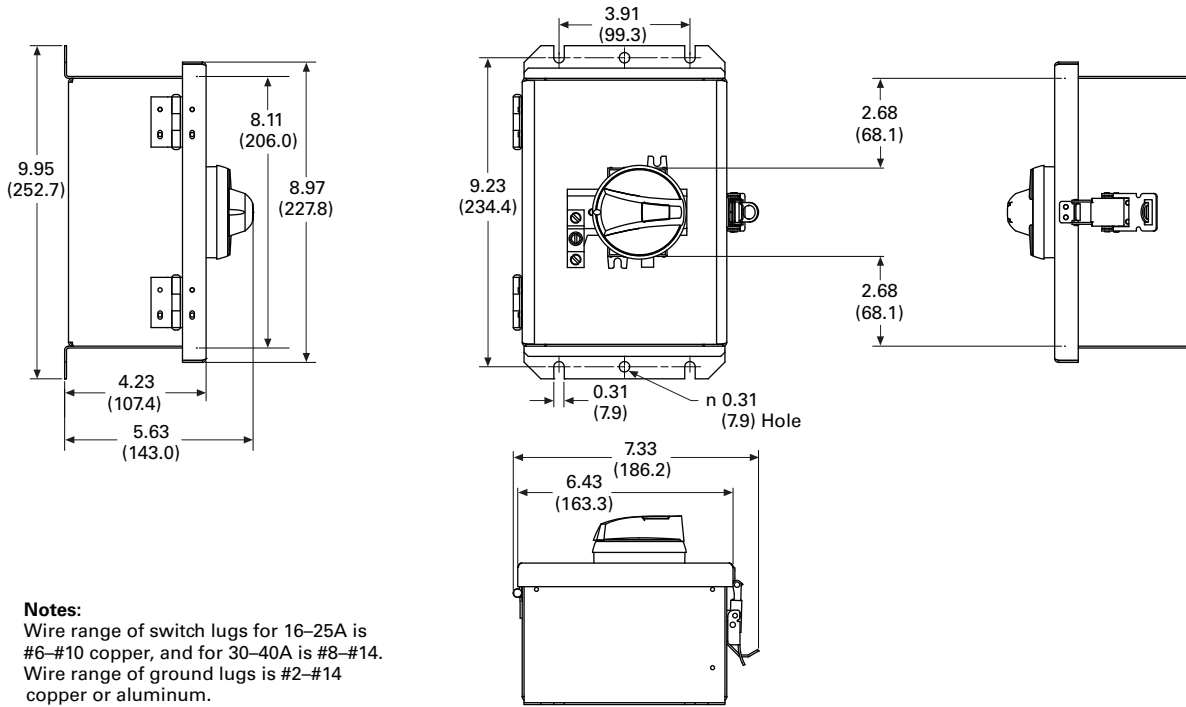

NEMA Type 4X Stainless (60–80A)

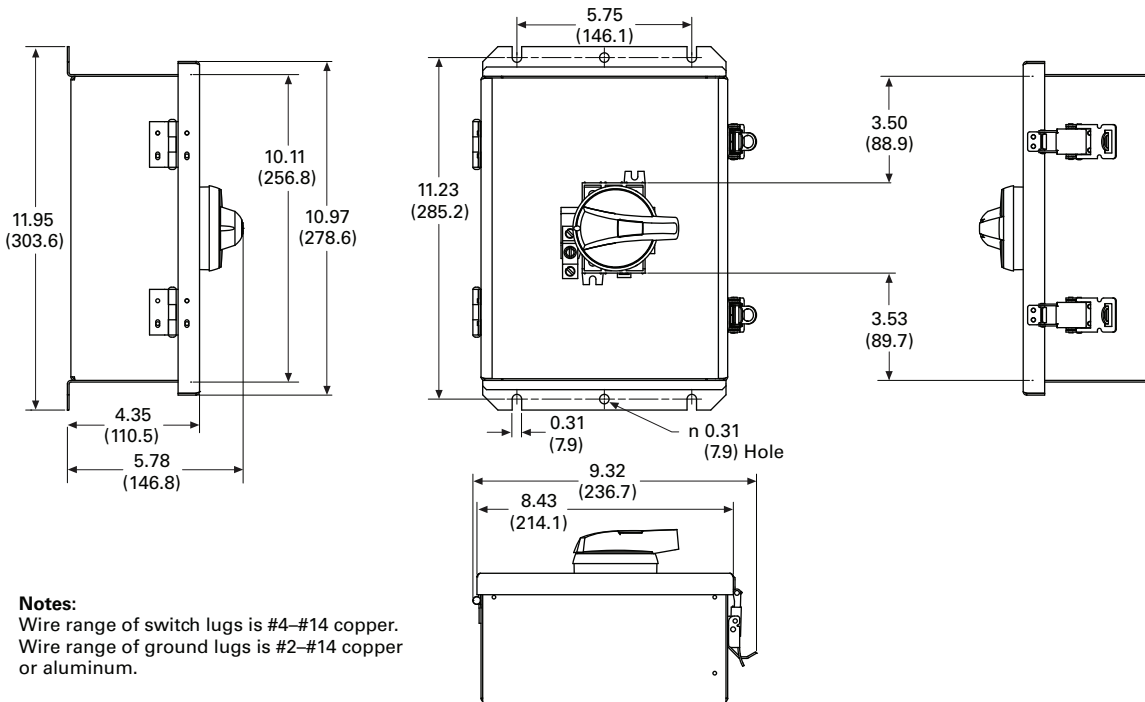

Approximate Dimensions in Inches (mm)

NEMA Type 4X Thermoset Polyester (16–40A)

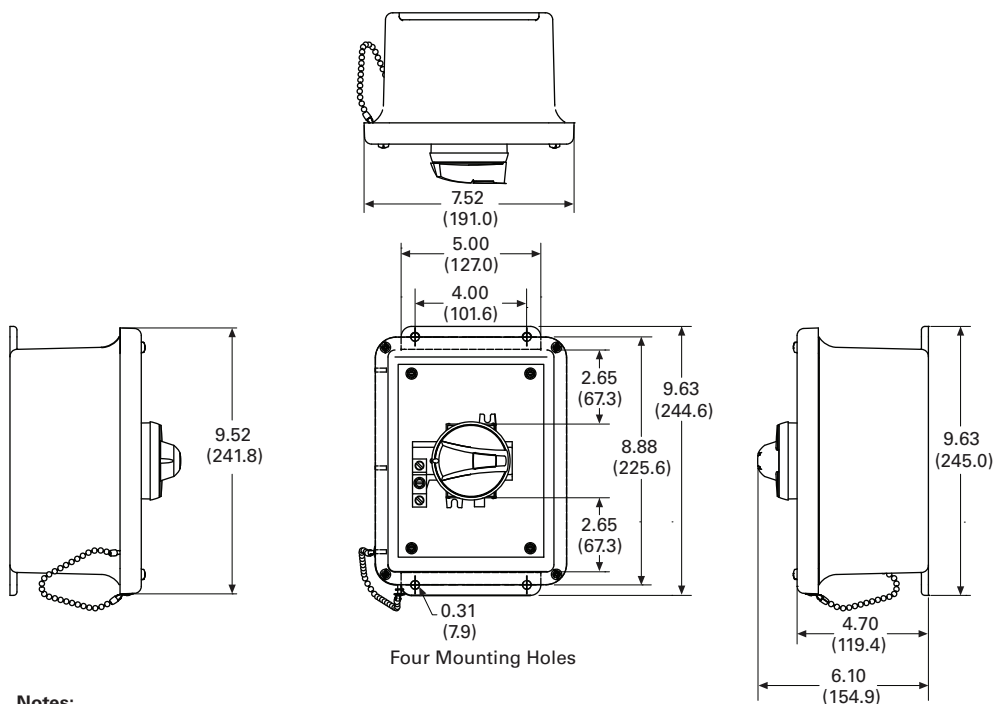

Notes:

Wire range of switch lugs for 16–25A is #6–#10 copper, and for 30–40A is #8–#14.
Wire range of ground lugs is #2–#14 copper or aluminum.

NEMA Type 4X Thermoset Polyester (60–80A)

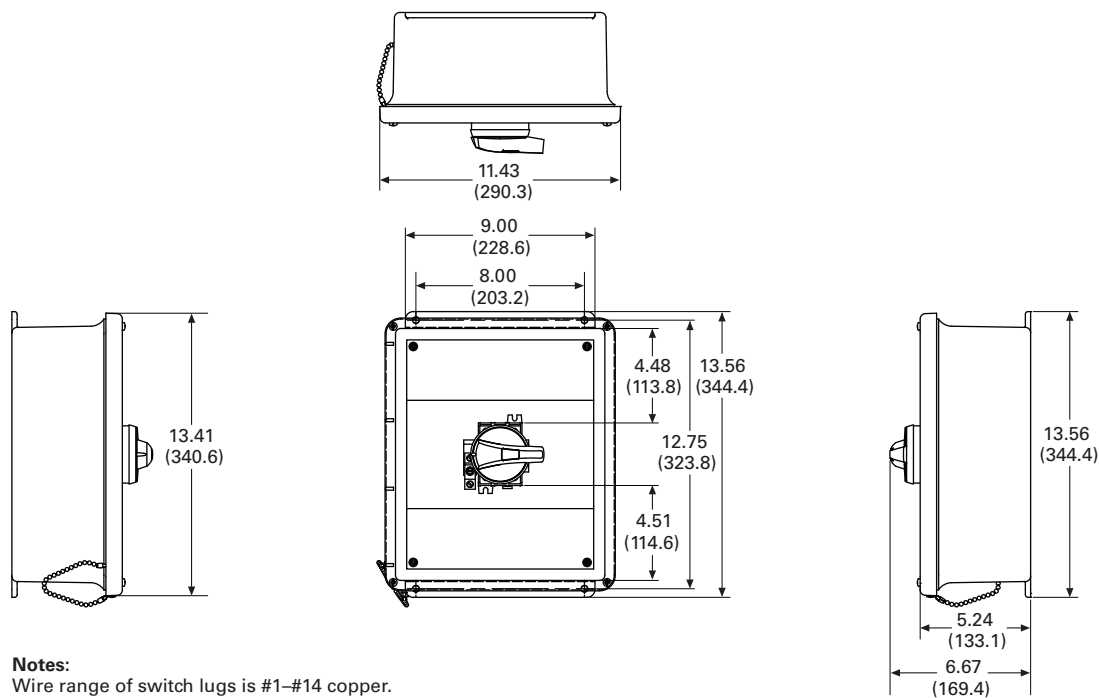

Notes:

Wire range of switch lugs is #1–#14 copper.
Wire range of ground lugs is #2–#14 copper or aluminum.

Switching Devices

Enclosed Rotary Disconnects

Approximate Dimensions in Inches (mm)

NEMA Type 4X—Polycarbonate (30A)

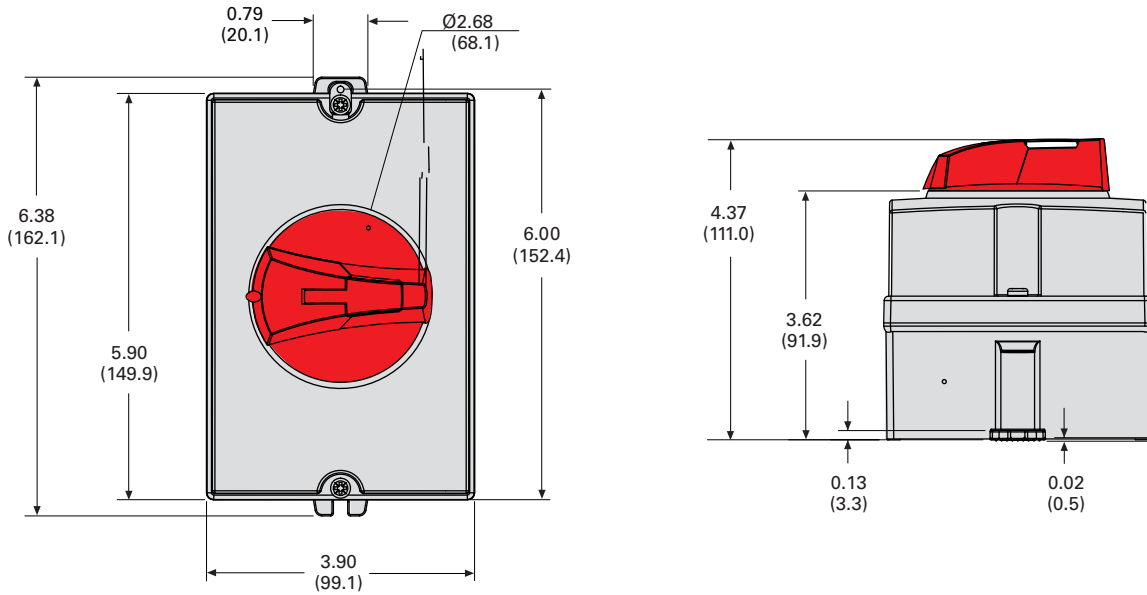

NEMA Type 4X—Polycarbonate (60A)

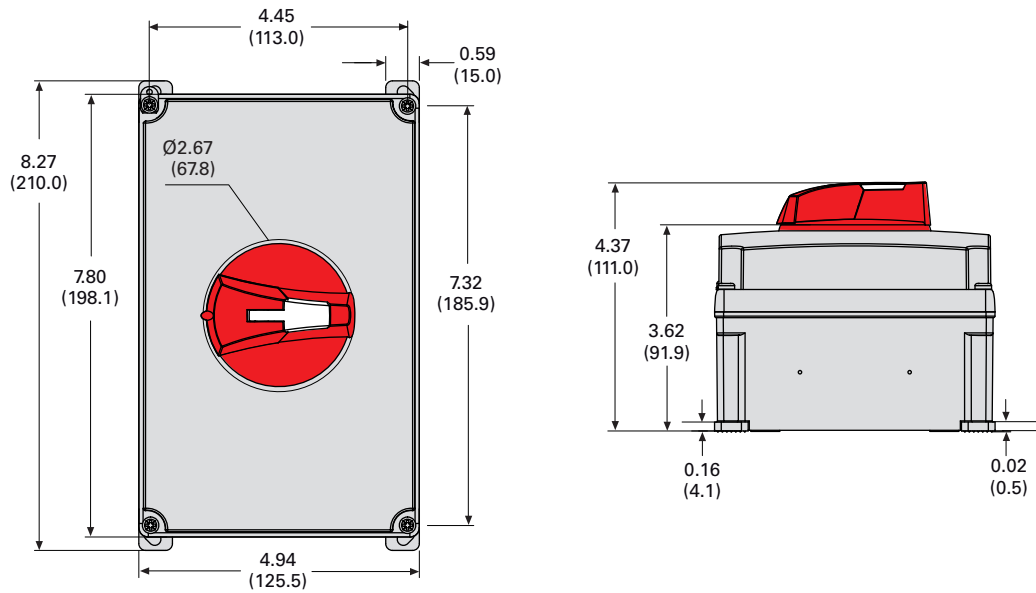

Notes:

Notes:

Notes:

Catalog Numbering Systems

Disconnects

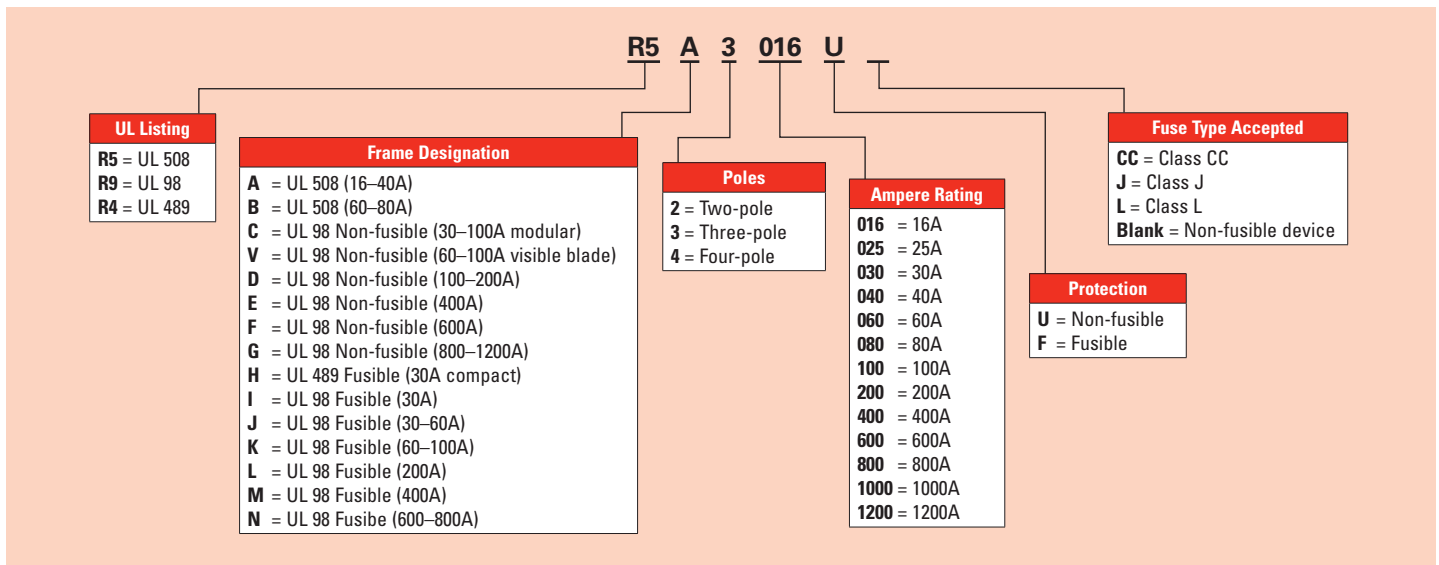



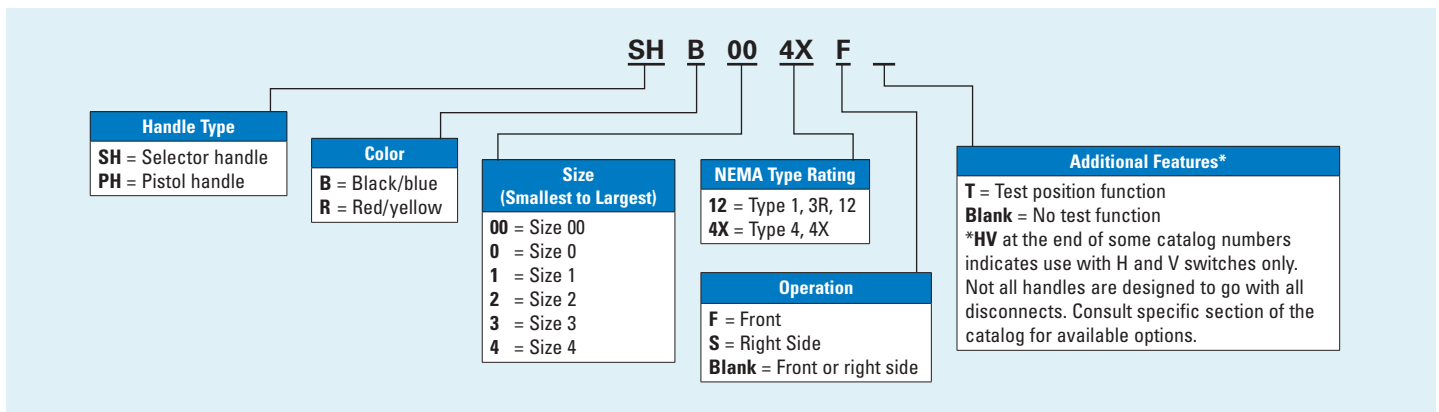



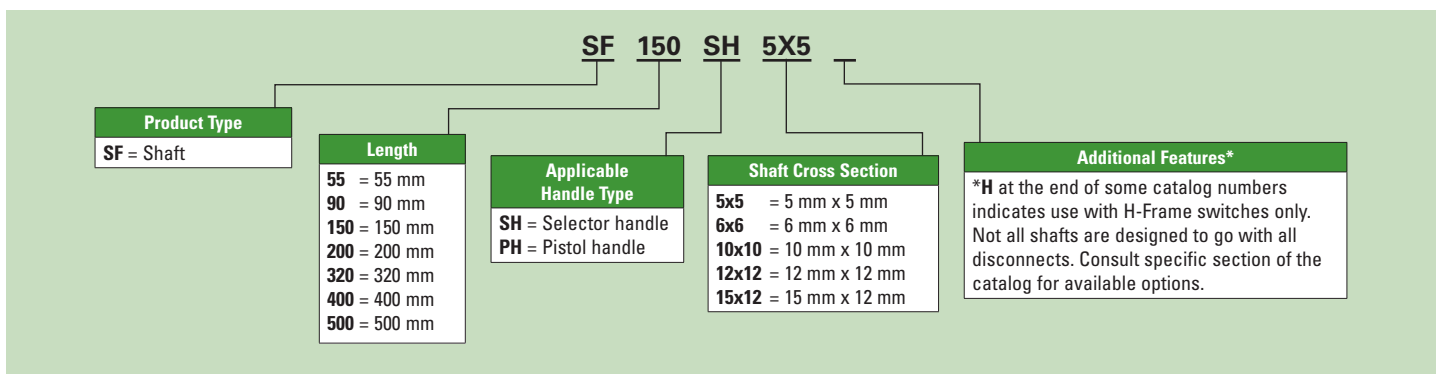





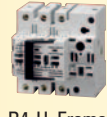





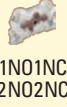







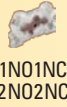

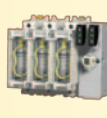

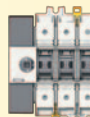



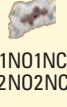







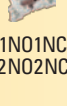









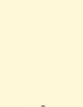

External Handles



Shafts

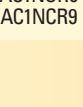

R Series Rotary Disconnects^①

Direct Handles	Auxiliary Contacts	Available Shafts	Fusible Disconnect	External Handles	Non-Fusible Disconnect	Available Shafts	Auxiliary Contacts	Direct Handles
 DHR9HC	 AC1NOR9 AC1NCR9	A SF___SH5X5H SF___PH5X5	 R4 H-Frame 30A-CC/J	 SH_00_	 R5 A- & B-Frame (16-40A & 60-80A)	A SF___SH5X5 SF___SH5X5	 AC1NONC AC2NO	 DHR5
 DHR9HJ	 AC1N01NCJ2N AC2N02NCJ2N  AC1NOR9 AC1NCR9	B SF___PH10X10	 R9 I-Frame 30A-CC	 SH_0_	 R9 C-Frame 30-100A Modular	A SF___SH5X5 SF___SH5X5	 AC1NONC AC2NO	 DHR9
 DHR9J2M	 AC1N01NCJ2N AC2N02NCJ2N  AC1NOR9 AC1NCR9	B SF___PH10X10	 R9 J-Frame 30-60A J ②	 PH_1_	 R9 V-Frame 60-100A Visible Blade	A SF___SH6X6 SF___PH6X6	 AC1NONC AC2NO  AC1NOR9 AC1NCR9	 DHR9V
 DHR9J2M	 AC1N01NCJ2N AC2N02NCJ2N  AC1NOR9 AC1NCR9	B SF___PH10X10	 R9 K-Frame 60-100A J ②	 PH_2_	 R9 D-Frame 100-200A	B SF___PH10X10	 AC1NONC_	 DHR9DE
 DHR9J2M	 AC1N01NCJ2N AC2N02NCJ2N  AC1NOR9 AC1NCR9	B SF___PH10X10	 R9 L-Frame 200A J	 PH_3_	 R9 E-Frame 400A	B SF___PH10X10	 AC1NONC_	 DHR9DE
 DHR9J2M	 AC1N01NCJ2N AC2N02NCJ2N  AC1NOR9 AC1NCR9	B SF___PH10X10	 R9 M-Frame 400A J	 PH_3_	 R9 F-Frame 600A	D SF___PH15X12	 AC1NOR9 AC1NCR9	 DHR9FG
 DHR9N	 AC1N01NCJ2N AC2N02NCJ2N  AC1NOR9 AC1NCR9	C SF___PH12X12	 R9 N-Frame 600-800A J/L	 PH_4_	 R9 G-Frame 800-1200A	D SF___PH15X12	 AC1NOR9 AC1NCR9 ACHFG	 DHR9FG

A



C



B



D



① For reference only—please consult specific catalog pages for detailed information.

② 60A J-Frame (100 kAIC), K-Frame (200 kAIC).

Eaton is dedicated to ensuring that reliable, efficient and safe power is available when it's needed most. With unparalleled knowledge of electrical power management across industries, experts at Eaton deliver customized, integrated solutions to solve our customers' most critical challenges.

Our focus is on delivering the right solution for the application. But, decision makers demand more than just innovative products. They turn to Eaton for an unwavering commitment to personal support that makes customer success a top priority. For more information, **visit www.eaton.com/electrical**.

Eaton Corporation
Electrical Sector
1111 Superior Avenue
Cleveland, OH 44114 USA
Eaton.com

© 2012 Eaton Corporation
All Rights Reserved
Printed in USA
Publication No. PG00802002E / Z12653
September 2012

Eaton is a registered trademark
of Eaton Corporation.

All other trademarks are property
of their respective owners.



Powering Business Worldwide