

FOR YOUR PERMANENT FILE

TESTER MODEL NUMBER:

TESTER SERIAL NUMBER:

For Warranty Claims, Contact CDI Torque Products
at (626) 965-0668.

LIMITED WARRANTY

The CDI Digital Torque Tester™ (DTT) is backed by a one year warranty. This warranty covers manufacturer defects and workmanship. The warranty excludes misuse, abuse and normal wear and tear. Exclusion is not allowed in some states and may not apply. This warranty gives you specific legal rights, and you may have other rights, which vary from state to state.



Please Recycle

IMPORTANT ENVIRONMENTAL NOTES:

1. This equipment may contain hazardous materials which can be harmful to the environment.
 2. Do not dispose of this equipment as municipal waste. Return it to the distributor or a designated collection center.
- Thank you for caring about our environment!

CDI TORQUE PRODUCTS

A Snap-on Specialty Tools Brand

19220 SAN JOSE AVENUE • CITY OF INDUSTRY, CA 91748 • USA
(626) 965-0668

Find other fine torque products at WWW.CDITORQUE.COM

Form 20-2344-CDI
6/2010 Rev. N/C

US and Foreign Patents Pending - Made in USA with US and Global Components

OPERATION MANUAL

DIGITAL TORQUE TESTER™ (DTT)



CDI TORQUE PRODUCTS

IMPORTANT SAFETY INSTRUCTIONS



This manual contains important safety and operating instructions for the Digital Torque Tester (DTT).



READ ALL INSTRUCTIONS

Read, understand and follow all safety messages and instructions in this manual and on the test equipment. Safety messages in this section of the manual contain a signal word, a three-part message, and, in some instances, an icon. An icon, when present, gives a graphical description of the potential hazard.

GENERAL CAUTIONS

CDI Torque Products cannot anticipate or provide safety warnings and cautions to cover every situation that may be encountered when operating, servicing or repairing this tester. It is the responsibility of operators and servicing technicians to be knowledgeable about the procedures, tools and materials used, and to satisfy themselves that the procedures, tools and materials will not compromise their safety.

Do not attempt to operate this Digital Torque Tester until you have thoroughly read and completely understand all instructions and safety information in this manual. Failure to comply can result in accidents involving fire, electric shock or serious personal injury. Save this manual and review it frequently for continued safe operation, and use it to instruct others who may use this tester.

CDI Torque Products is not responsible for customer modification of test equipment for applications on which CDI Torque Products was not consulted.

SAVE THESE INSTRUCTIONS

GENERAL SAFETY



WARNING

Improper use can cause breakage.

- Read instructions before operating.
- Follow manufacturer's instructions, safety precautions, and specifications when operating tools.

Broken equipment can cause injury.



USERS AND BYSTANDERS SHOULD ALWAYS WEAR EYE PROTECTION

- Flying particles can be discharged when applying torque.

Flying particles can cause injury.



Risk of entanglement.

- Keep body parts away from rotating parts.
- Wear a protective hair covering to contain long hair and prevent contact with moving parts.
- Do not overreach. Keep proper footing and balance at all times.

Entanglement can cause injury.



TORQUE TESTER SAFETY



WARNING

- Be sure ratings for all components, including, adaptors, extensions, drivers and sockets, match or exceed the torque being applied.
- Do not use this instrument with power switch OFF. Always turn power switch ON so torque values are displayed.
- Do not turn the power switch ON with a torque instrument engaged to tester transducer.
- Be sure the capacity of the DTT matches or exceeds each application before performing a procedure.
- Pull on a wrench handle—do not push—when tester is mounted horizontally. Adjust stance to prevent a possible fall.
- Pull on a wrench handle—do not push—when tester is mounted horizontally. Adjust stance to prevent a possible fall.
- Do not use extensions, such as a pipe, on a wrench handle.

TORQUE TESTER SAFETY



- Fully engage the direction lever in the correct position when using ratchets. Never attempt to test an impact tool or pulse type tool on this instrument.
- Mount the DTI securely to a heavy bench, wall or other support structure before applying torque.
- Do not use the DTT if it makes unusual noises, has loose parts, or shows any other sign of damage. Have repairs performed at an Authorized Service Center before use.
- Do not use chipped, cracked, or damaged sockets and accessories.
- Do not remove any labels. Replace any damaged label.

AC ADAPTER SAFETY

Risk of electric shock and fire.

- Do not allow conductive objects to come in contact with terminals. 120 or 220 volts present at adapter terminals.
- For indoor use only. Do not expose adapter to rain or snow. Do not use in damp locations.
- Replace defective cord immediately. Return to qualified service center for replacement.
- Do not use any other type of adapter. Using an adapter not specifically designed for this unit may damage tester.
- Do not use an extension cord with adapter.
- Do not use a damaged adapter.
- Do not disassemble adapter.
- Do not attempt to connect two adapters together.
- Do not operate adapter with damaged cord or plug. Replace immediately.
- Do not operate adapter after it is dropped, receives a sharp blow or damaged. Take the adapter to an Authorized Service Center.
- Unplug adapter from outlet before maintenance or cleaning. Turning off tester is not adequate to avoid hazard.
- Read all instructions and safety messages on battery and adapter before use.

Electric shock or fire can cause injury.



DTT SYSTEM COMPONENTS

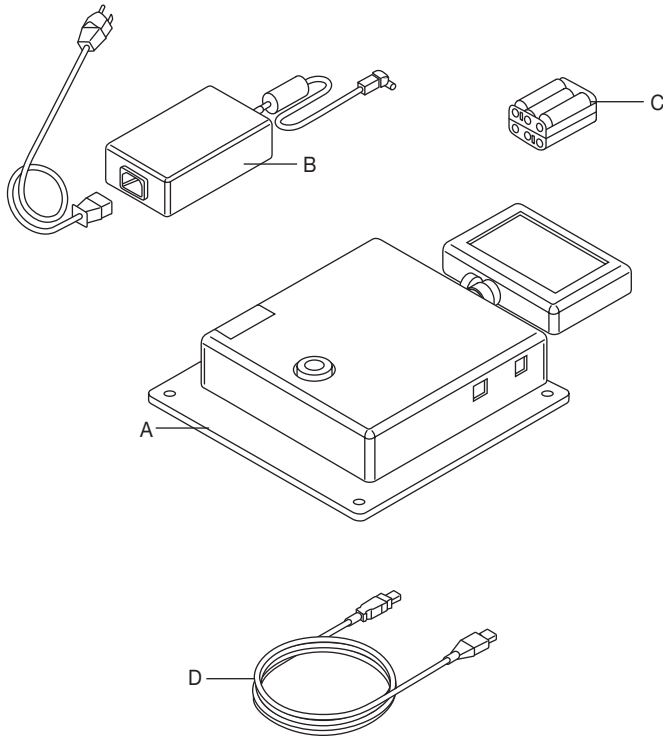

Figure 1: Digital Torque Tester (DTT) System Components

A - Digital Torque Tester (DTT)

B - AC Adapter

AC/DC transformer, Voltage Output: 9VDC,
Current 1.66A

C - Battery Pack

Battery holder with 6 AA Battery Cells

D - USB Cable

INTRODUCTION

Use the portable DTT to test “click” type torque wrenches (adjustable and preset), torque screwdrivers, dial indicating and electronic wrenches.

The tester features a swivel-neck LCD display with selectable English or Metric units of measure. 11 models are available, ranging from 10-100 in.oz. to 60-600 ft.lb.

The DTT displays torque values using a built-in strain-gaged transducer with an accuracy of $\pm 0.5\%$ of indicated test value from 10% to 100% of rated capacity, in clockwise (CW) and counter-clockwise (CCW) directions.

TORQUE VALUES

Capture and display torque values in one of four selectable modes:

- **CLICK ADJUST (First Peak)**
 - Responds to the drop-off in torque caused by the “click” of an adjustable wrench. FIRST PEAK torque is measured, captured and displayed (CW or CCW) just prior to the drop-off, even if click torque is subsequently exceeded.
- **CLICK PRESET (First Peak)**
 - Responds to the drop-off in torque caused by the “click” of a preset wrench. FIRST PEAK torque is measured, captured and displayed (CW or CCW) just prior to the drop-off, even if click torque is subsequently exceeded.
- **DIAL / ELECT (Peak Hold)**
 - Captures and displays the highest torque applied (CW or CCW) until reset. Use to check dial indicating and electronic torque wrenches.
- **SCREWDRIVER (Peak Hold)**
 - Captures and displays the highest torque applied (CW or CCW) until reset. Use to check torque limiting screwdrivers.

This manual contains general information. Operating features and specifications may change without notice. CDI Torque makes no claims regarding the suitability of the information in this manual for diverse user applications.

POWER SOURCE

The power source for the DTT is the supplied AC Adapter. The tester can also be operated with the use of the 6 AA Battery Pack that accompanies the tester.

FUNCTIONAL DESCRIPTION

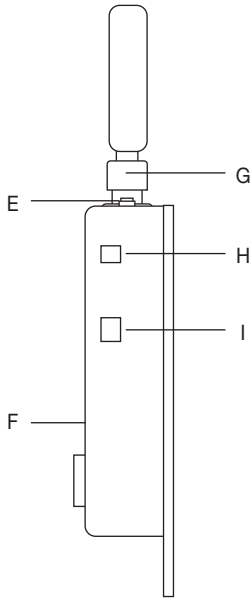
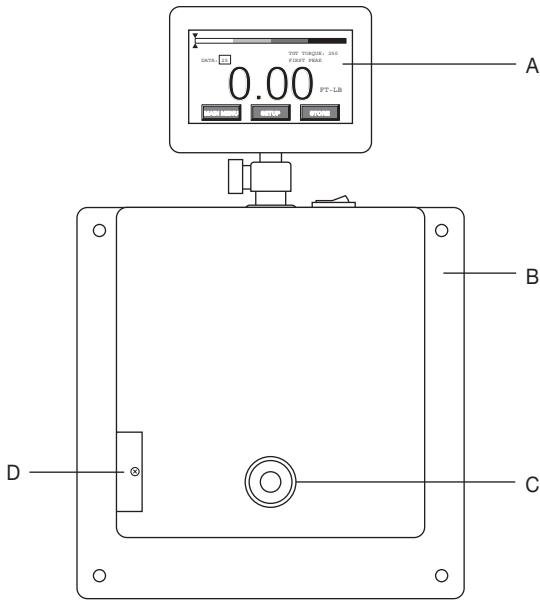

A - Display

A four digit TFT display for torque readings.

B - Mounting Plate

Plate for securing tester to mounting surface. Use four 1/4" diameter bolts.

C - Transducer

Female square drive.

D - Battery Access

Battery Pack housing panel. Remove Phillips screw to access Battery Pack.

E - Power Switch

Rocker switch turns power to tester on and off.

F - Audible Alert

Signal sounds momentarily when:

- Power to tester is initiated,
- Anytime a button is pressed, and
- Target Torque is reached.

G - Swivel

Holds the display for view from any angle.

H - AC Adapter Jack

Receptacle (9VDC @ 1.66A max) for continuous AC operation.

I - USB Jack

Receptacle for uploading torque data to an external computer.

Figure 2: Digital Torque Tester (DTT), Front and Side Views

SPECIFICATIONS

DISPLAY

LCD on swivel neck

DISPLAY SPECIFICATIONS

Size: 4.7 inch

Resolution: 480 (RGB) X 272

ACCURACY

±0.5% of indicated test value from 10% to 100% of rated capacity

UNITS OF MEASUREMENT

ft.lb., in.lb., in.oz., kgcm, Nm and cNm

Operating Temperature

0 - 50°C (32 - 122°F)

STORAGE

-20 - 70°C (-4 - 158°F)

DIMENSIONS

Width: 10.0"

Height: 15.2"

Depth: 2.5"

WEIGHT

11 lbs

BATTERY

Six 1 .5V (AA), replaceable

AC ADAPTER

Input: 100 240VAC (50-60 Hz)

Output: 9VDC, 1 .66A

INTEGRAL TRANSDUCER

Full bridge strain gage,
350 ohms, 1500 µE, 3mV/V F.S., 3.3V excitation

TRANSDUCER RANGE AND DISPLAY RESOLUTIONS

DTT built-in transducers provide industry standard female square drives, and a full bridge strain gage sensing element.

Contact your CDI Torque representative for service and/or calibration.

IMPORTANT

Apply torque loads only. Never side-load a wrench while installed on the tester transducer.

IMPORTANT

Transducers can withstand a torque of 25% over full range. Do not use the tester if the transducer:

- Does not zero,
- Does not calibrate, or
- Has been over-torqued.

The table below describes minimum and maximum display ranges.

| Part Number | Square Drive | Units | |
|-------------|--------------|-------------------|----------------|
| | | English | Metric |
| 1001-O-DTT | 1/4" | 10.0-100.0 in.oz. | 7.0-70.6 cNm |
| 2001-O-DTT | 1/4" | 20.0-200.0 in.oz. | 14.1-141.2 cNm |
| 4001-O-DTT | 1/4" | 40.0-400.0 in.oz. | 28.2-282.4 cNm |
| 251-I-DTT | 1/4" | 2.5-25.0 in.lb. | 2.8-28.25 dNm |
| 501-I-DTT | 1/4" | 5.00-50.00 in.lb. | 5.65-56.50 dNm |
| 1001-I-OTT | 1/4" | 10.0-100.0 in.lb. | 11.3-113.0 dNm |
| 2502-I-DTT | 3/8" | 25.0-250.0 in.lb. | 28.2-282.5 dNm |
| 4002-I-DTT | 3/8" | 40.0-400.0 in.lb. | 45.2-452.0 dNm |
| 10002-I-DTT | 3/8" | 100-1000.0 in.lb. | 113-1130 dNm |
| 2503-F-DTT | 1/2" | 25.0-250.0 ft.lb. | 33.9-339.0 Nm |
| 6004-F-DTT | 3/4" | 60.0-600.0 ft.lb. | 81.3-813.6 Nm |

SETUP

MOUNTING

Mount the DTT to a sturdy support before use. Torque testing procedures may involve hundreds of pounds of load. Be sure to consider counterweight of the mount to accommodate torque testing operations and testing fixtures. Allow enough room around and below the mount for the wrenches or testing fixtures being used.

Vertical mounting on a wall or heavy pillar is preferred for most wrench and tool testing as shown in the illustration below. Use four 1/4" diameter bolts (torqued to 10 ft.lb.) to insure a secure mount. The DTT can also be mounted vertically to a horizontal surface using a right angle bracket.

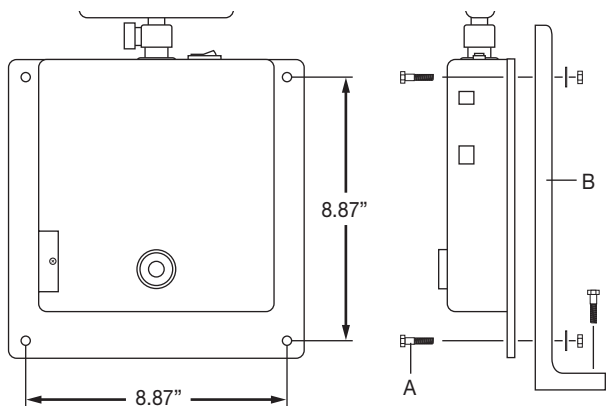

Figure 3: Mounting, Dimensions and Right Angle Bracket

A - Mounting Screw (4)

B- Right Angle Bracket

TESTER SETUP

1. Turn the power switch ON.
2. In the MAIN MENU screen, select DTT SETTINGS.
3. In the SYSTEM CONFIGURATION screen, the display reads:

| | |
|-------------|--------------------|
| DATE: | MONTH / DAY / YEAR |
| TIME: | HOUR/MINS |
| BRIGHTNESS: | 30-100 |

4. To increment or decrement the DATE/TIME/BRIGHTNESS elements, select the element and repeatedly press the UP or DOWN arrows.

NOTE: Press and hold the UP or DOWN arrows to change the display quickly. The scrolling DATE/TIME elements roll over at both ends for quick and convenient adjustment of settings.

5. Press NEXT to update DATE/TIME/BRIGHTNESS and return to the MAIN MENU.

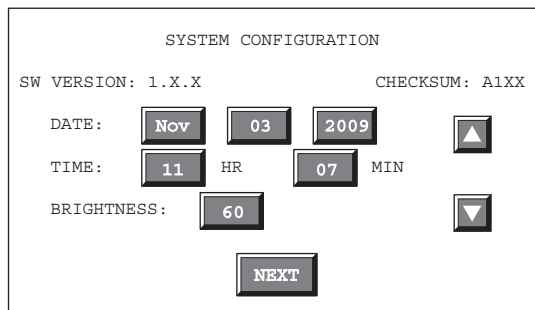

Figure 4: System Configuration screen

TESTS

TESTING WRENCHES

IMPORTANT

- To avoid damage, be sure the DTT model being used is capable of handling the torque being applied.
- Always position a torque wrench within 15° of perpendicular to the display housing (Figure 5).

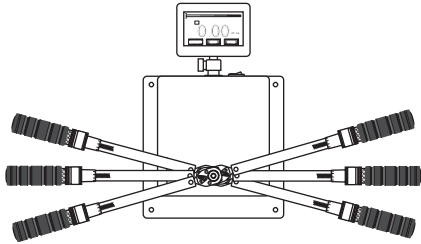

Figure 5: Wrench Position, Perpendicular to Tester

1. Prepare tester for use. For additional information refer to TESTER SETUP.

NOTE: DTT will ZEROTARE automatically when power switch is turned ON.



WARNING

Do not turn the power switch ON with a torque instrument engaged to tester transducer.

2. In the MAIN MENU screen, select TEST.

NOTE: The operator can return to the MAIN MENU at any step during this procedure by pressing the MAIN button.

3. In the SELECT WRENCH TYPE screen, select one of the following options:

CLICK ADJUST

CLICK PRESET

DIAL / ELEC

SCREWDRIVER

4. In the SELECT TEST TYPE screen, select either: QUICK CHECK (used when verifying torque wrench readings), or AUDIT (used when testing a torque wrench)

QUICK CHECK MODE

- 5a. If QUICK CHECK is selected in Step 4, the tester will display the TEST SETUP screen (Figure 6).

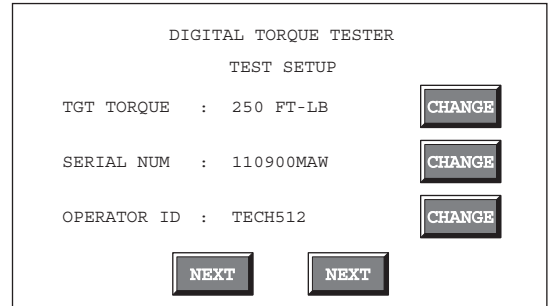

Figure 6: Test Setup screen (Quick Check mode)

- 5b. Press the CHANGE button next to TGT TORQUE to enter the Target Torque Value and Units desired (Figure 7).

NOTE: If the incorrect value is entered, press BS to clear the last digit entered, or press CLEAR to delete the entire entry.

Press UNITS to scroll between FT-LB, IN-LB, IN-OZ, KG-CM, Nm and cNm units.

Press NEXT to accept the entry and return to the TEST SETUP screen.

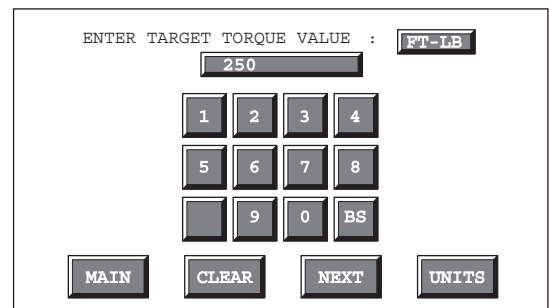

Figure 7: Target Torque Value screen

TESTS

5c. Press the CHANGE button next to SERIAL NUM to enter a wrench Serial Number if required (Figure 8).

NOTE: The WRENCH S/N screen can be changed from Numerical (Figure 8) to Alphabetical (Figure 9) Mode and vice versa by pressing the 0-9 or A-Z key respectively.

If the incorrect value is entered, press BS to clear the last digit entered, or press CLEAR to delete the entire entry.

The WRENCH S/N screen can be left blank If the Serial Number information is not required.

A 12 digit long alpha.numehc combination can be entered in the WRENCH SIN screen.

Press NEXT to accept the entry and return to the TEST SETUP screen.

5d. Press the CHANGE button next to OPERATOR ID to enter an Operator Identification number if required (Figure 10).

NOTE: The OPERATOR ID screen can be changed from Alphabetical (Figure 10) to Numerical (Figure 11) Mode and vice versa by pressing the A-Z or 0-9 key respectively.

If the incorrect value is entered, press BS to clear the last digit entered, or press CLEAR to delete the entire entry.

The OPERATOR ID screen can be left blank If the Operator Identification is not required.

An 8 digit long alpha-numeric combination can be entered in the OPERATOR ID screen.

Press NEXT to accept the entry and return to the TEST SETUP screen.

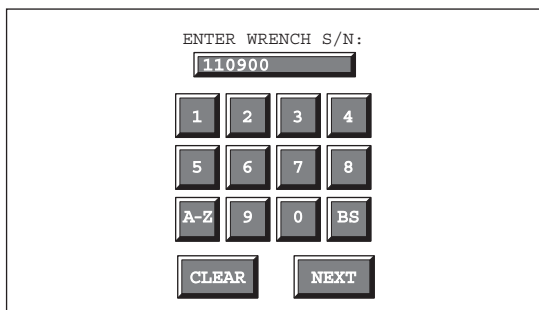

Figure 8: Wrench Serial Number screen (Numeric Mode)

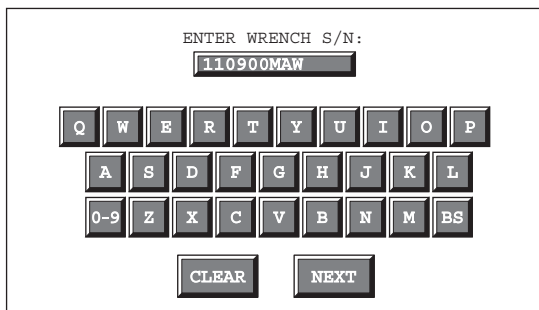

Figure 9: Wrench Serial Number screen (Alphabetical Mode)

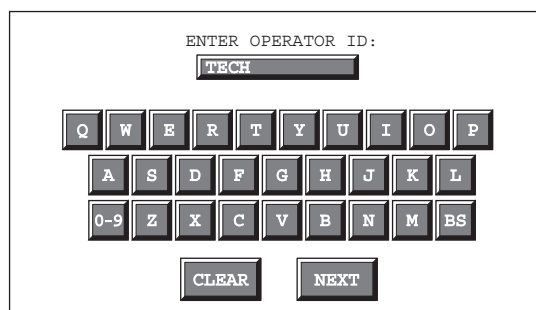

Figure 10: Operator ID screen (Alphabetical Mode)

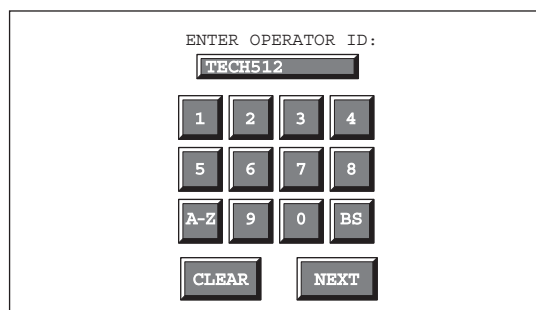

Figure 11: Operator ID screen (Numeric Mode)

TESTS

5e. Press the TEST button to accept all entries and display the QUICK CHECK test screen (Figure 12).

NOTE: The operator can return to the TEST SETUP screen by pressing the SETUP button.

5f. Install the wrench on the transducer and apply torque.

5g. Press STORE to save torque measurements in the internal memory. Torque measurements can be offloaded to a PC using the USB cable. For additional information refer to Data Offload.

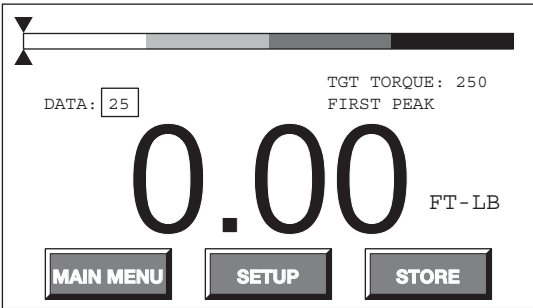

Figure 12: Quick Check test screen

AUDIT MODE

6a. If AUDIT is selected in Step 4, the tester will display Audit Mode the TEST SETUP screen (Figure 13).

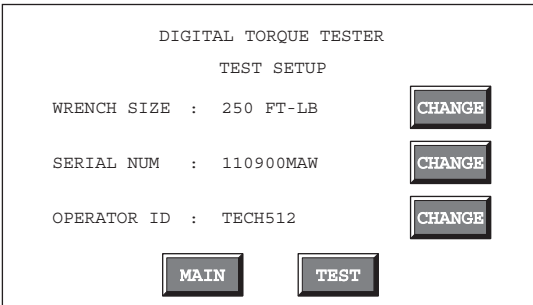

Figure 13: Test Setup screen (Audit Mode)

6b. Press the CHANGE button next to WRENCH SIZE to enter the Full Scale torque and Units of the wrench being calibrated (Figure 14).

NOTE: If the incorrect value is entered, press BS to clear the last digit entered, or press CLEAR to delete the entire entry.

Press UNITS to scroll between FT-LB, IN-LB, IN-OZ, KG-CM, Nm and cNm units.

Press NEXT to accept the entry and return to the TEST SETUP screen.

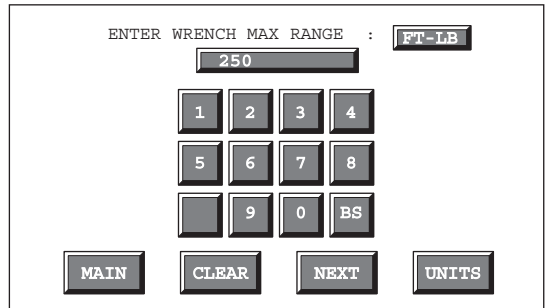

Figure 14: Wrench Max Range screen

NOTE: For information on how to update SERIAL NUM, and OPERATOR ID; please refer to Steps 5c & 5d.

Press TEST to accept all entries.

TESTS

6c. The tester will prompt user to set wrench to 20% of Full Scale (Figure 15).

For example:

If WRENCH MAX RANGE (Step 6b) is entered as 250 FT-LB, the DTT will prompt user to set wrench to 50 FT-LB.

Press NEXT.

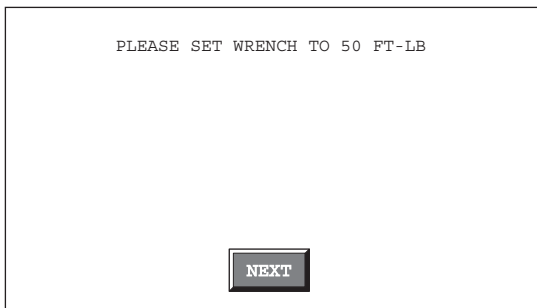

Figure 15: Wrench Set prompt screen

6d. The display will change to the 20% test screen (Figure 16).

Install the wrench on the transducer.

The screen will display a test counter which indicates the number of times the user must apply torque at the 20% setting:

TEST 1 of 3
TEST 2 of 3
TEST 3 of 3

Apply torque until the wrench reaches 50 FT-LB. Then press STORE to advance the test counter. Repeat procedure until counter reaches 3 of 3.

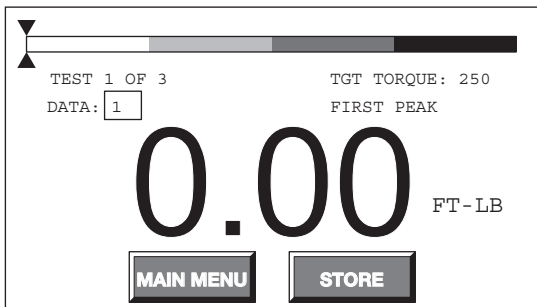

Figure 16: 20% torque test screen

6e. The tester will prompt user to set wrench to 60% of Full Scale (Figure 17).

For example:

If WRENCH MAX RANGE (Step 6b) is entered as 250 FT-LB, the DTT will prompt user to set wrench to 150 FT-LB.

Press NEXT.



Figure 17: Wrench Set prompt screen

6f. The display will change to the 60% test screen (Figure 18).

Install the wrench on the transducer.

The screen will display a test counter which indicates the number of times the user must apply torque at the 60% setting:

TEST 1 of 3
TEST 2 of 3
TEST 3 of 3

Apply torque until the wrench reaches 150 FT-LB. Then press STORE to advance the test counter. Repeat procedure until counter reaches 3 of 3. The stored data will also accumulate in the primary store box.

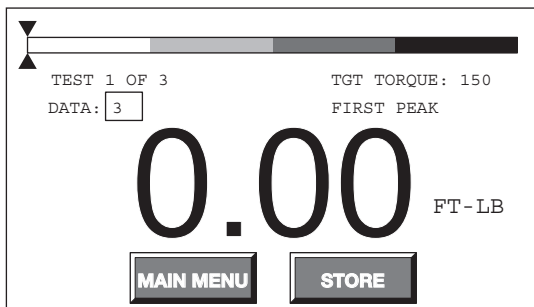

Figure 18: 60% torque test screen

TESTS

6g. The tester will prompt user to set wrench to 100% of Full Scale (Figure 19).

For example:

If WRENCH MAX RANGE (Step 6b) is entered as 250 FT-LB, the DTT will prompt user to set wrench to 250 FT-LB.

Press NEXT.



Figure 19: Wrench Set prompt screen

6h. The display will change to the 100% test screen (Figure 20).

Install the wrench on the transducer.

The screen will display a test counter which indicates the number of times the user must apply torque at the 100% setting:

- TEST 1 of 3
- TEST 2 of 3
- TEST 3 of 3

Apply torque until the wrench reaches 250 FT-LB. Then press STORE to advance the test counter. Repeat procedure until counter reaches 3 of 3. The stored data will also accumulate in the primary store box.

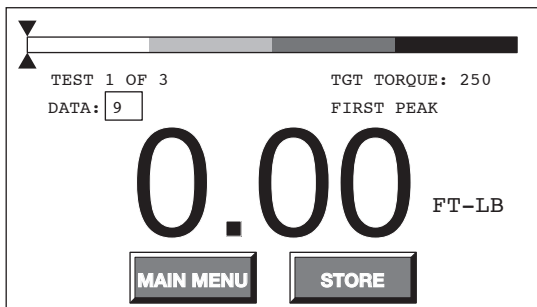

Figure 20: 100% torque test screen

6i. At the end of the test sequence, the tester will return to the TEST SETUP screen in order to begin a new test sequence. To continue the test sequence in the CCW direction, press TEST.

6j. Stored torque measurements can be offloaded to a PC using the USB cable. For additional information refer to Data Offload.

DATA OFFLOAD

Torque measurements are stored in the internal memory everytime the STORE button is pressed during the testing procedure. DTT tester allows users to offload saved data to a PC via the USB cable.

To retrieve saved data:

- Connect the USB cable between the DTT and PC USB ports.
- Turn the DTT switch ON.
- On the PC, double click the DTTDATA.CSV file located in MY COMPUTER \ DTT.
- The DTTDATA file will contain the following information (Figure 21):

TIME
DATE
OPERATOR ID
WRENCH SERIAL NUMBER
ACTUAL TORQUE
TARGET TORQUE
ERROR (%)
UNITS

To delete saved data:

- Deleted the DTTDATA.CSV file located in MY COMPUTER \ DTT

| TIME | DATE | OPERATOR ID | WRENCH S/N | ACT TORQUE | TGT TORQUE | ERR(%) | UNITS |
|----------|----------|-------------|------------|------------|------------|--------|-------|
| 11:18:41 | 11/12/09 | store 321 | 12342009 | 40.34 | 40 | 0.84 | FT-LB |
| 11:18:44 | 11/12/09 | store 321 | 12342009 | 41.01 | 40 | 2.52 | FT-LB |
| 11:18:47 | 11/12/09 | store 321 | 12342009 | 40.35 | 40 | 0.88 | FT-LB |
| 11:19:53 | 11/12/09 | store 321 | 12342009 | 121.39 | 120 | 1.16 | FT-LB |
| 11:19:55 | 11/12/09 | store 321 | 12342009 | 121.1 | 120 | 0.92 | FT-LB |
| 11:19:58 | 11/12/09 | store 321 | 12342009 | 121.15 | 120 | 0.96 | FT-LB |
| 11:20:47 | 11/12/09 | store 321 | 12342009 | 203.75 | 200 | 1.88 | FT-LB |
| 11:20:50 | 11/12/09 | store 321 | 12342009 | 202.78 | 200 | 1.39 | FT-LB |
| 11:20:54 | 11/12/09 | store 321 | 12342009 | 202.84 | 200 | 1.42 | FT-LB |

Figure 21: Stored Data Information