



Liebert®

DataMate™

Installer/User Guide

15-ton to 3-ton Capacity, 50 Hz and 60 Hz

The information contained in this document is subject to change without notice and may not be suitable for all applications. While every precaution has been taken to ensure the accuracy and completeness of this document, Vertiv assumes no responsibility and disclaims all liability for damages resulting from use of this information or for any errors or omissions. Refer to other local practices or building codes as applicable for the correct methods, tools, and materials to be used in performing procedures not specifically described in this document.

The products covered by this instruction manual are manufactured and/or sold by Vertiv. This document is the property of Vertiv and contains confidential and proprietary information owned by Vertiv. Any copying, use or disclosure of it without the written permission of Vertiv is strictly prohibited.

Names of companies and products are trademarks or registered trademarks of the respective companies. Any questions regarding usage of trademark names should be directed to the original manufacturer.

Technical Support Site

If you encounter any installation or operational issues with your product, check the pertinent section of this manual to see if the issue can be resolved by following outlined procedures.

Visit <https://www.Vertiv.com/en-us/support/> for additional assistance.

TABLE OF CONTENTS

1 Important Safety Instructions	1
1.1 AHRI Certified	6
1.2 Agency Listed	7
2 Nomenclature	9
2.1 Nomenclature for Evaporator and Chilled Water Units	9
2.2 Nomenclature for Condensing Units	10
2.2.1 Outdoor Prop Fan Condensing Units for Air Cooled Systems	10
2.2.2 Indoor Condensing Units for Air Cooled Systems	11
2.2.3 Close Coupled Condensing Unit for Water/Glycol Cooled Systems	12
2.2.4 Remote, Indoor Water/Glycol Cooled Condensing Units	13
2.3 System Configurations	14
3 Site Preparation and Equipment Handling	17
3.1 Planning Dimensions	17
3.2 Room Preparation	17
3.3 Application Limits	17
3.4 Location Considerations	18
3.4.1 Location Considerations for Evaporator, Indoor Condensing and Chilled Water Units	19
3.4.2 Location Considerations for an Outdoor Condensing Unit	20
3.5 Unit Weights	21
3.6 Equipment Inspection and Handling	21
4 Installation	23
4.1 Installing Wall Mounted Evaporators and Chilled Water Units	23
4.1.1 Changing Air Flow Direction	23
4.2 Installing Outdoor Condensing Unit for Air Cooled Split Systems	23
4.3 Installing Ceiling Mounted Condensing Units	23
4.3.1 Installing Suspension Rods and Mounting Ceiling Units	24
4.3.2 Guidelines for Ducted Systems	26
4.4 Close Coupled Installations for Integral Water/Glycol Condensing Units	27
4.4.1 Connecting the Close Coupled Refrigerant Circuit	33
4.4.2 Connecting the Close Coupled Electrical Wiring	35
4.4.3 Final Installation Steps for Close Coupled Units	36
5 Piping and Refrigerant Requirements	37
5.1 Fluid Piping Required	38
5.1.1 Evaporator Drain Line Installation Requirements	38
5.1.2 Humidifier Drain Line Installation Requirements	38
5.1.3 Condensate Drain Pump Kit	38
5.1.4 Water Supply Line to the Humidifier	39
5.1.5 Chilled Water Loop Piping	39

5.1.6 Water/Glycol Loop Piping	40
5.2 Refrigerant Piping	42
5.2.1 Piping when Condensing Unit is Above or Below Evaporator	43
5.2.2 Refrigerant Line Sizes and Equivalent Lengths	44
5.3 Refrigerant Charge Requirements	45
5.3.1 Field Fabricated Refrigeration Piping	46
5.3.2 Evacuation and Leak Testing Air Cooled Systems	46
5.3.3 Charging Air Cooled Systems	49
5.3.4 Field Charge Verification for Air Cooled Systems	49
5.3.5 Documenting Refrigerant Charge on Air Cooled Units	50
5.3.6 Evacuation and Leak Testing Water/Glycol Cooled Systems	50
5.3.7 Charging Water/Glycol Cooled Systems	52
5.3.8 Optimizing Refrigerant Charge on Water/Glycol Units	53
5.3.9 Documenting Refrigerant Charge on Water/Glycol-cooled Units	53
6 Electrical Connection Requirements	55
6.1 Input Power Connection Requirements	56
6.2 Control Wiring Connection Requirements	57
6.2.1 Wall Box Controller Control Connections	57
6.2.2 Split System Condensing Unit Control Connections	57
6.2.3 Water/Glycol Cooled Unit Control Connections	57
6.2.4 Additional Control Connections	57
7 Checklist for Completed Installation	59
8 Initial Start-up Checks and Commissioning Procedure for Warranty Inspection	61
9 Microprocessor Control	63
9.1 Controller Operation	63
9.1.1 Powering On/Off with Wall Mounted Display	64
9.1.2 Silencing an Audible Alarm	64
9.2 Main Menu <MENU>	64
9.2.1 Editing Setpoints	67
9.2.2 Viewing Unit Status	67
9.2.3 Viewing Active Alarms	68
9.2.4 Setting Controller Time	68
9.2.5 Setting Controller Date	68
9.2.6 Programming Setback	68
9.2.7 Editing Setup Operation	69
9.2.8 Changing Setpoint and Setup Passwords	71
9.2.9 Calibrating Sensors and Setting Sensor Response Delay	71
9.2.10 Enabling/Disabling Alarms	72
9.2.11 Setting Alarm Delays	72
9.2.12 Activating the Common Alarm Relay	73

9.2.13	Configuring Custom Alarms	74
9.2.14	Customizing Alarm Message Text	74
9.2.15	LCD Display Contrast	74
9.2.16	Non-volatile Memory	74
9.2.17	Equipment Options DIP Switches	75
9.3	Running Diagnostics	76
9.3.1	Showing Test Inputs	76
9.3.2	Testing Outputs	76
9.3.3	Testing the Microcontroller	77
9.4	System Control and Performance	80
9.4.1	Temperature Control	80
9.4.2	Cooling/Heating Required	80
9.4.3	Electric Reheat	80
9.4.4	Humidity Control	80
9.4.5	Load Control	81
9.4.6	Monitoring	81
9.5	Alarm Notification, Acknowledgment, and Descriptions	81
9.5.1	Custom Alarms	81
9.5.2	High Head Pressure Alarm	82
9.5.3	Humidity Level Alarms	82
9.5.4	Temperature Level Alarms	83
9.5.5	Humidifier Problem Alarm	83
9.5.6	Loss of Power Alarm	83
9.5.7	Short Cycle Alarm	83
10	Maintenance	85
10.1	System Testing	86
10.1.1	Environmental Control Function Tests	86
10.1.2	Cooling Test	86
10.1.3	Heating Test	86
10.1.4	Humidification Test	86
10.1.5	Dehumidification Test	86
10.1.6	Remote Shutdown Test	86
10.2	Filter Maintenance	87
10.3	Electric Panel Maintenance	87
10.4	Direct Drive Blower Package Maintenance	87
10.4.1	Fan Impeller and Motor Bearing Maintenance	87
10.4.2	Air Distribution Inspection	87
10.5	Electric Reheat Maintenance	87
10.6	Refrigeration System Maintenance	87
10.6.1	Refrigeration Suction Pressure	87

10.6.2 Refrigeration Discharge Pressure	87
10.6.3 Thermostatic Expansion Valve (TXV) Maintenance	88
10.6.4 Air Cooled Condensing Unit Maintenance	88
10.6.5 Hot Gas Bypass Operation and Maintenance	88
10.6.6 Water/Glycol Condenser Maintenance	90
10.6.7 Regulating Valve Maintenance (Water/Glycol Cooled Condensers Only)	90
10.6.8 Glycol Solution Maintenance	90
10.7 Compressor Maintenance	91
10.7.1 Mechanical Failure of the Compressor	91
10.7.2 Electrical Failure of the Compressor	91
10.7.3 Replacement Compressors	92
10.7.4 Replacing a Failed Compressor	92
10.8 Steam Generating Humidifier Maintenance	92
10.8.1 Operating the Humidifier	93
10.8.2 Replacing the Canister	94
10.8.3 Circuit Board Adjustments	95
11 Preventive Maintenance Checklist	97
12 Troubleshooting	101
Appendices	105
Appendix A: Technical Support and Contacts	105
Appendix B: Submittal Drawings	107

1 IMPORTANT SAFETY INSTRUCTIONS

SAVE THESE INSTRUCTIONS

This manual contains important safety instructions that should be followed during the installation and maintenance of the Liebert® DataMate. Read this manual thoroughly before attempting to install or operate this unit.

Only qualified personnel should move, install or service this equipment.

Adhere to all warnings, cautions, notices and installation, operating and safety instructions on the unit and in this manual. Follow all installation, operation and maintenance instructions and all applicable national and local building, electrical and plumbing codes.



WARNING! Arc flash and electric shock hazard. Open all local and remote electric power supply disconnect switches, verify with a voltmeter that power is Off and wear appropriate, OSHA approved personal protective equipment (PPE) per NFPA 70E before working within the electric control enclosure. Failure to comply can cause serious injury or death. Customer must provide earth ground to unit, per NEC, CEC, and local codes, as applicable. Before proceeding with installation, read all instructions, verify that all the parts are included and check the nameplate to be sure the voltage matches available utility power. The Liebert® controller does not isolate power from the unit, even in the Unit Off mode. Some internal components require and receive power even during the Unit Off mode of the controller. The only way to ensure that there is NO voltage inside the unit is to install and open a remote disconnect switch. Refer to unit electrical schematic. Follow all local codes.



WARNING! Risk of electric shock. Can cause equipment damage, injury, or death. Open all local and remote electric power supply disconnect switches and verify with a voltmeter that power is off before working within any electric connection enclosures. Service and maintenance work must be performed only by properly trained and qualified personnel and in accordance with applicable regulations and manufacturers' specifications. Opening or removing the covers to any equipment may expose personnel to lethal voltages within the unit even when it is apparently not operating and the input wiring is disconnected from the electrical source.



WARNING! Risk of over-pressurization of the refrigeration system. Can cause piping rupture, explosive discharge of high pressure refrigerant, loss of refrigerant, environmental pollution, equipment damage, injury, or death. This unit contains fluids and gases under high pressure. Use extreme caution when charging the refrigerant system. Do not pressurize the system higher than the design pressure marked on the unit's nameplate. Relieve pressure before cutting into or making connections/disconnections to the piping system. Local building or plumbing codes may require installing a pressure relief device in the system.

Consult local building and plumbing codes for installation requirements of additional pressure relief devices when isolation valves are field installed. Do not isolate any refrigerant circuits from over-pressurization protection. The PFH and MCD condensing units include a factory installed pressure relief valve mounted on top of the receiver. The valve is rated for a maximum working pressure of 475 psig.



WARNING! Risk of contact with high speed, rotating fan blades. Can cause injury or death. Open all local and remote electric power supply disconnect switches, verify with a voltmeter that power is off, and verify that all fan blades have stopped rotating before working in the unit cabinet.



WARNING! Risk of electric shock. Can cause serious injury or death. The microprocessor does not isolate power from the unit, even in the Unit Off mode. Some internal components require and receive power even during the Unit Off mode of the control. Open all local and remote electric power disconnect switches and verify with a voltmeter that power is Off before working on any component of the system.



WARNING! Risk of improper wiring, piping, moving, lifting and handling. Can cause equipment damage, serious injury or death. Installation and service of this equipment should be done only by qualified personnel, wearing appropriate, OSHA approved PPE, who have been specially trained in the installation of air conditioning equipment.



WARNING! Risk of improper wire and loose electrical connections. Can cause overheated wire and electrical connection terminals resulting in smoke, fire, equipment and building damage, injury or death. Use correctly sized copper wire only and verify that all electrical connections are tight before turning power On. Check all electrical connections periodically and tighten as necessary.



WARNING! Risk of unit falling off of the wall. Can cause building and equipment damage and serious injury. A licensed professional structural engineer should evaluate the wall to determine if the unit may be safely mounted on the wall and determine the type and size of fasteners required to support the weight of the unit during all phases of operation because some vibration may occur during start, stop, and operation cycles. The wall may need to be reinforced to support the maximum load of the unit. See **Table 3.5** on page 21, for unit weights.



WARNING! Risk of ceiling collapse and heavy unit falling. Can cause building and equipment damage, serious injury or death. If using a ceiling mounted condensing unit, verify that the supporting roof structure is capable of supporting the weight of the unit(s) and the accessories. See the appropriate condensing unit installer/user guide for the unit weights. Securely anchor the top ends of the suspension rods and verify that all nuts are tight.



WARNING! Risk of smoke and fire. Can cause activation of fire suppression systems, building evacuation, dispatching of fire/rescue equipment and personnel and catastrophic canister failure resulting in water leaks, equipment damage, injury or death. Using a humidifier canister that has reached the end of its service life can be extremely hazardous. If the canister cannot be replaced immediately at the end of life condition, turn Off the power and water supply to the humidifier and remove the canister until a replacement canister can be installed. Do not ignore humidifier problem alarms. Resetting humidifier without addressing cause may result in fire or damage due to leaking water.



CAUTION: Risk of excessive refrigerant line pressure. Can cause tubing and component rupture resulting in equipment damage and personal injury. Do not close off any field installed refrigerant line isolation valve for repairs unless a pressure relief valve is field installed in the line between the isolation valve and the check valve. The pressure relief valve must be rated 5% to 10% higher than the system design pressure. An increase in ambient temperature can cause the pressure of the isolated refrigerant to rise and exceed the system design pressure rating (marked on the unit nameplate).



CAUTION: Risk of contact with sharp edges, splinters, and exposed fasteners. Can cause injury. Only properly trained and qualified personnel wearing appropriate, OSHA approved PPE should attempt to move, lift, remove packaging from or prepare the unit for installation.



CAUTION: Risk of contact with hot surfaces. Can cause injury. The compressor, refrigerant discharge lines, fan motor, and some electrical components are extremely hot during unit operation. Allow sufficient time for them to cool to a touch-safe temperature before working within the unit cabinet. Use extreme caution and wear appropriate, OSHA approved PPE when working on or near hot components.



CAUTION: Risk of contact with hot surfaces. Can cause burn injury. The humidifier canister and steam discharge lines are extremely hot during operation. Allow sufficient time for them to cool to a touch-safe temperature before handling. Use extreme caution and wear appropriate, OSHA approved PPE when performing maintenance on the humidifier.



CAUTION: Risk of contacting caustic substances. Can cause injury. Avoid touching or contacting the gas and oils with exposed skin. Severe burns will result. Wear appropriate, OSHA approved PPE when handling contaminated parts.

NOTICE

Risk of oil contamination with water. Can cause equipment damage.

Liebert® DataMate DX systems require the use of POE (polyolester) oil. POE oil absorbs water at a much faster rate when exposed to air than previously used oils. Because water is the enemy of a reliable refrigeration system, extreme care must be used when opening systems during installation or service. If water is absorbed into the POE oil, it will not be easily removed and will not be removed through the normal evacuation process. If the oil is too wet, it may require an oil change. POE oils also have a property that makes them act as a solvent in a refrigeration system. Maintaining system cleanliness is extremely important because the oil will tend to bring any foreign matter back to the compressor.

NOTICE

Risk of clogged or leaking drain lines and leaking water supply lines. Can cause equipment and building damage.

This unit requires a water drain connection. Drain lines must be inspected at start-up and periodically, and maintenance must be performed to ensure that drain water runs freely through the drain system and that lines are clear and free of obstructions and in good condition with no visible sign of damage or leaks. This unit may also require an external water supply to operate.

Improper installation, application and service practices can result in water leakage from the unit. Water leakage can result in catastrophic and expensive building and equipment damage and loss of critical data center equipment.

Do not locate unit directly above any equipment that could sustain water damage.

We recommend installing a monitored fluid detection system to immediately discover and report coolant fluid system and condensate drain line leaks.

NOTICE

Risk of leaking water/glycol. Can cause equipment and building damage.

Improper installation, application, and service practices can result in water leakage from the unit. Do not mount this unit over equipment and furniture that can be damaged by leaking water. Install a water-tight drain pan with a drain connection under the cooling unit and the ceiling mounted water/glycol condensing unit. Route the drain line to a frequently used maintenance sink so that running water can be observed and reported in a timely manner. Post a sign to alert people to report water flowing from the secondary drain pan. We recommend installing monitored leak detection equipment for the unit and supply lines and in the secondary drain pan. Check drain lines periodically for leaks, sediment buildup, obstructions, kinks and/or damage and verify that they are free running.

NOTICE

Risk of piping system corrosion and freezing fluids. Can cause leaks resulting in equipment and very expensive building damage. Cooling coils and piping systems are at high risk of freezing and premature corrosion. Fluids in these systems must contain the proper antifreeze and inhibitors to prevent freezing and premature coil and piping corrosion. The water or water/glycol solution must be analyzed by a competent local water treatment specialist before start-up to establish the inhibitor and antifreeze solution requirement and at regularly scheduled intervals throughout the life of the system to determine the pattern of inhibitor depletion.

The complexity of water/glycol solution condition problems and the variations of required treatment programs make it extremely important to obtain the advice of a competent and experienced water treatment specialist and follow a regularly scheduled coolant fluid system maintenance program.

Water chemistry varies greatly by location, as do the required additives, called inhibitors, that reduce the corrosive effect of the fluids on the piping systems and components. The chemistry of the water used must be considered, because water from some sources may contain corrosive elements that reduce the effectiveness of the inhibited formulation. Sediment deposits prevent the formation of a protective oxide layer on the inside of the coolant system components and piping. The water/coolant fluid must be treated and circulating through the system continuously to prevent the buildup of sediment deposits and or growth of sulfate reducing bacteria.

Proper inhibitor maintenance must be performed in order to prevent corrosion of the system. Consult glycol manufacturer for testing and maintenance of inhibitors.

Commercial ethylene glycol, when pure, is generally less corrosive to the common metals of construction than water itself. It will, however, assume the corrosivity of the water from which it is prepared and may become increasingly corrosive with use if not properly inhibited.

We recommend installing a monitored fluid detection system that is wired to activate the automatic closure of field installed coolant fluid supply and return shut-off valves to reduce the amount of coolant fluid leakage and consequential equipment and building damage. The shut-off valves must be sized to close off against the maximum coolant fluid system pressure in case of a catastrophic fluid leak.

NOTICE

Risk of frozen pipes and corrosion from improper coolant mixture. Can cause water leaks resulting in equipment and building damage.

When piping or the cooling unit may be exposed to freezing temperatures, charge the system with the proper percentage of glycol and water for the coldest design ambient temperature. Automotive antifreeze is unacceptable and must NOT be used in any glycol fluid system. Use only HVAC glycol solution that meets the requirements of recommended industry practices.

NOTICE

Risk of no flow condition. Can cause equipment damage. Do not leave the water/coolant fluid supply circuit in a no flow condition. Idle fluid allows the collection of sediment that prevents the formation of a protective oxide layer on the inside of tubes. Keep unit switched On and water/coolant fluid supply circuit system operating continuously.

NOTICE

Risk of improper water supply. Can reduce humidifier efficiency or obstruct humidifier plumbing.

Do not use completely demineralized water with this unit. The water must contain minerals for the electrode principle to work.

Do not use a hot water source. It will cause deposits that will eventually block the fill valve opening.

NOTICE

Risk of water backing up in the drain line. Leaking and overflowing water can cause equipment and building damage.

Do not install an external trap in the drain line. This line already has a factory installed trap inside the cabinet. Installation of a second trap will prevent drain water flow and will cause the water to overflow the drain pan.

This line may contain boiling water. Use copper or other material that is rated for handling boiling water for the drain line. Sagging condensate drain lines may inadvertently create an external trap.

NOTICE

Risk of doorway/hallway interference. Can cause unit and/or structure damage. The unit may be too large to fit through a doorway or hallway while on the skid. Measure the unit and passageway dimensions, and refer to the installation plans prior to moving the unit to verify clearances.

NOTICE

Risk of damage from forklift. Can cause unit damage. Keep tines of the forklift level and at a height suitable to fit below the skid and/or unit to prevent exterior and/or underside damage.

NOTICE

Risk of improper storage. Can cause unit damage.

Keep the unit upright, indoors and protected from dampness, freezing temperatures and contact damage.

1.1 AHRI Certified

The Liebert® DataMate™ 60-Hz system is AHRI Certified™, the trusted mark of performance assurance for heating, ventilation, air conditioning, and commercial refrigeration equipment, using AHRI Standard 1360.

1.2 Agency Listed

Standard 60-Hz units are CSA Certified to the harmonized U.S. and Canadian product safety standard CSA C22.2 No 236/UL 1995 for “Heating and Cooling Equipment” and are marked with the CSA c-us logo.



This page intentionally left blank

2 NOMENCLATURE

This section describes the model number configuration for Liebert® DataMate units and components.

2.1 Nomenclature for Evaporator and Chilled Water Units

Table 2.2 below describes each digit of the model number.

Table 2.1 Nomenclature Example

1	2	3	4	5	6	7	8	9	10	11
D	M	E	0	3	7	E	—	P	H	N

Table 2.2 Nomenclature Digit Definitions for Evaporator and Chilled Water Units

Digit	Description
Digits 1, 2, 3 =	The Base unit DME = DataMate evaporator/chilled water cooling unit
Digits 4, 5, 6 =	Nominal Capacity, kBTuh
Digit 7, 8 =	Cooling Type C – = Chilled water cooled E – = Evaporator
Digit 9 =	Supply Power P = 208/230 V / 1 ph / 60 Hz W = 200/220 V / 1 ph / 50 Hz
Digit 10 =	Reheat and Humidification O = Reheat only C = Cooling only H = Reheat and humidifier
Digit 11 =	Refrigerant/Revision N = R-407C, field-supplied, field-charged (evaporator) 7 = Revision (chilled water)

2.2 Nomenclature for Condensing Units

This section describes the model number configuration for DataMate condensing units.

2.2.1 Outdoor Prop Fan Condensing Units for Air Cooled Systems

Table 2.4 below describes each digit of the model number.

Table 2.3 Prop Fan Condensing Unit Nomenclature Example

1	2	3	4	5	6	7	8	9	10	11
P	F	H	0	3	7	A	—	P	L	N

Table 2.4 Nomenclature Digit Definitions for Outdoor, Prop Fan Condensing Units

Digit	Description
Digits 1 to 3 = The Base Unit	PFH = Prop fan condensing unit with hot gas bypass
Digit 4 = Sound Level	0 = Standard Z = Quiet-Line
Digit 5 and 6 = Nominal Capacity, kBtuh	
Digit 7 = Cooling Type	A = Air cooled
Digit 8 = Coil Type	— = Standard coil C = Coated coil (epoxy with UV topcoat)
Digit 9 = Supply Power	A = 460 V / 3 ph / 60 Hz B = 575 V / 3 ph / 60 Hz M = 380/415 V / 3 ph / 50 Hz P = 208/230 V / 1 ph / 60 Hz S = 220 V / 1 ph / 50 Hz Y = 208/230 V / 3 ph / 60 Hz
Digit 10 = Ambient Rating/Control	L = 95°F Ambient, Liebert® Lee-Temp™ H = 105°F Ambient, Liebert® Lee-Temp™
Digit 11 = Refrigerant	N = R-407C field-supplied, field-charged

2.2.2 Indoor Condensing Units for Air Cooled Systems

Table 2.6 below describes each digit of the model number.

Table 2.5 Indoor, Air Cooled Condensing Unit Nomenclature Example

1	2	3	4	5	6	7	8	9	10
M	C	D	3	6	A	L	A	H	N

Table 2.6 Nomenclature Digit Definitions for Indoor, Air Cooled Condensing Units

Digit	Description
Digits 1 to 2 = the Base Unit	MC = Mini-Mate2-style condensing unit
Digit 3 = Disconnect	D = Disconnect switch
Digit 4 and 5 = Nominal Capacity	24 = 24 kBtuh, 2-ton, 60 Hz 35 = 35 kBtuh, 3-ton, 50 Hz 36 = 36 kBtuh, 3-ton, 60 Hz
Digit 6 = Cooling Type	A = Air cooled
Digit 7 = Head Pressure Control	L = Liebert® Lee-Temp™ Receiver
Digit 8 = Supply Power	A = 460 V / 3 ph / 60 Hz M = 380/415 V / 3 ph / 50 Hz P = 208/230 V / 1 ph / 60 Hz S = 220 V / 1 ph / 50 Hz X = 277 V / 1 ph / 50 Hz Y = 208/230 V / 3 ph / 60 Hz
Digit 9 = Hot Gas Bypass	H = Hot gas bypass
Digit 10 = Refrigerant	N = R-407C field-supplied, field-charged

2.2.3 Close Coupled Condensing Unit for Water/Glycol Cooled Systems

Table 2.8 below describes each digit of the model number.

Table 2.7 Close Coupled Water/Glycol Condensing Unit Nomenclature Example

1	2	3	4	5	6	7	8	9	10	11
D	M	C	0	4	0	W	G	P	0	N

Table 2.8 Nomenclature Digit Definitions for Close Coupled Water/Glycol Units

Digit	Description
Digits 1, 2, 3 = The Base Unit	DMC = DataMate condensing unit
Digits 4, 5, 6 = Nominal Capacity, kBTuh	
Digit 7, 8 = Cooling Type	WG = Water/Glycol cooled
Digit 9 = Supply Power	P = 208/230 V / 1 ph / 60 Hz
Digits 10, 11 = Refrigerant	0N = R-407C, field-supplied, field-charged

2.2.4 Remote, Indoor Water/Glycol Cooled Condensing Units

Table 2.10 below describes each digit of the model number.

Table 2.9 Remote, Indoor Water/Glycol Condensing Unit Nomenclature Example

1	2	3	4	5	6	7	8	9	10
M	C	D	3	8	W	2	A	H	N

Table 2.10 Nomenclature Digit Definitions for Indoor, Water/Glycol Cooled Condensing Units

Digit	Description
Digits 1 to 2 = The Base Unit	MC = Mini-Mate2-style condensing unit
Digit 3 = Disconnect	D = Disconnect switch
Digit 4 and 5 = Nominal Capacity, kBtuh	
Digit 6 = Cooling Type	W = Water/Glycol cooled
Digit 7 = Head Pressure Control	2 = 2-way standard pressure fluid regulating valve 3 = 3-way standard pressure fluid regulating valve D = 2-way high pressure fluid regulating valve T = 3-way high pressure fluid regulating valve
Digit 8 = Supply Power	A = 460 V / 3 ph / 60 Hz M = 380/415 V / 3 ph / 50 Hz P = 208/230 V / 1 ph / 60 Hz S = 220 V / 1 ph / 50 Hz X = 277 V / 1 ph / 50 Hz Y = 208/230 V / 3 ph / 60 Hz
Digit 9 = Hot Gas Bypass	H = Hot gas bypass
Digit 10 = Refrigerant	N = R-407C field-supplied, field-charged

2.3 System Configurations

The following figures show the available capacity and cooling options for the Liebert® DataMate.

Figure 2.1 Air Cooled Units

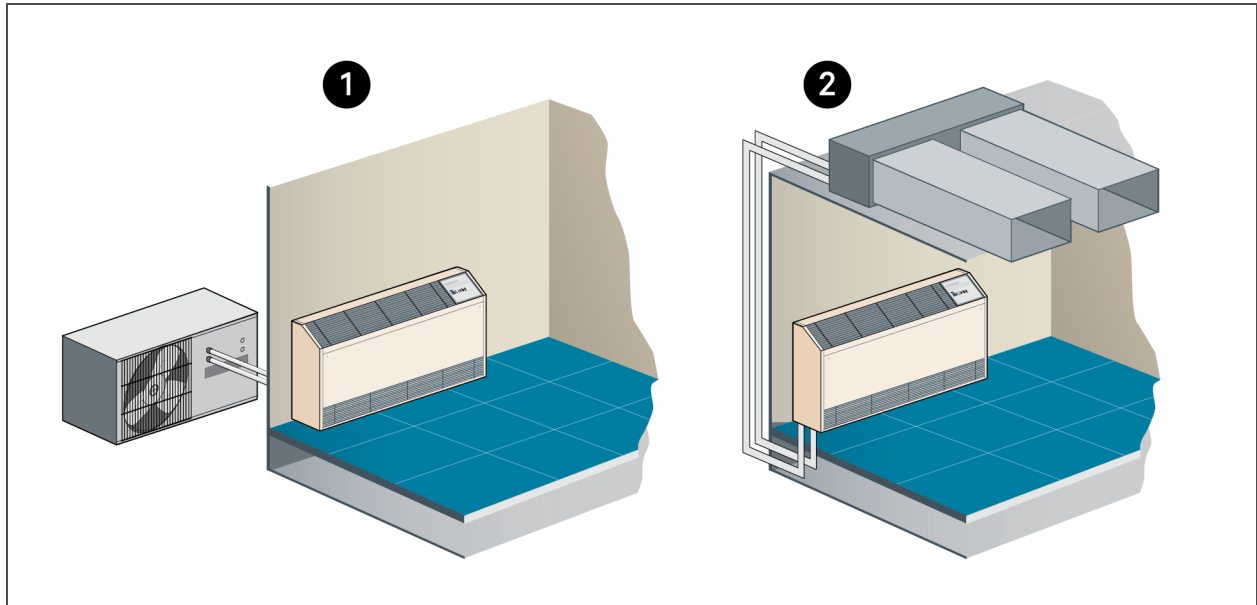

Item	Description
1	Air cooled with outdoor condensing unit suitable for installation on a roof or at ground level.
2	Air cooled with indoor condensing unit for applications where roof or other outdoor locations are impractical.

Figure 2.2 Water/Glycol Cooled Units

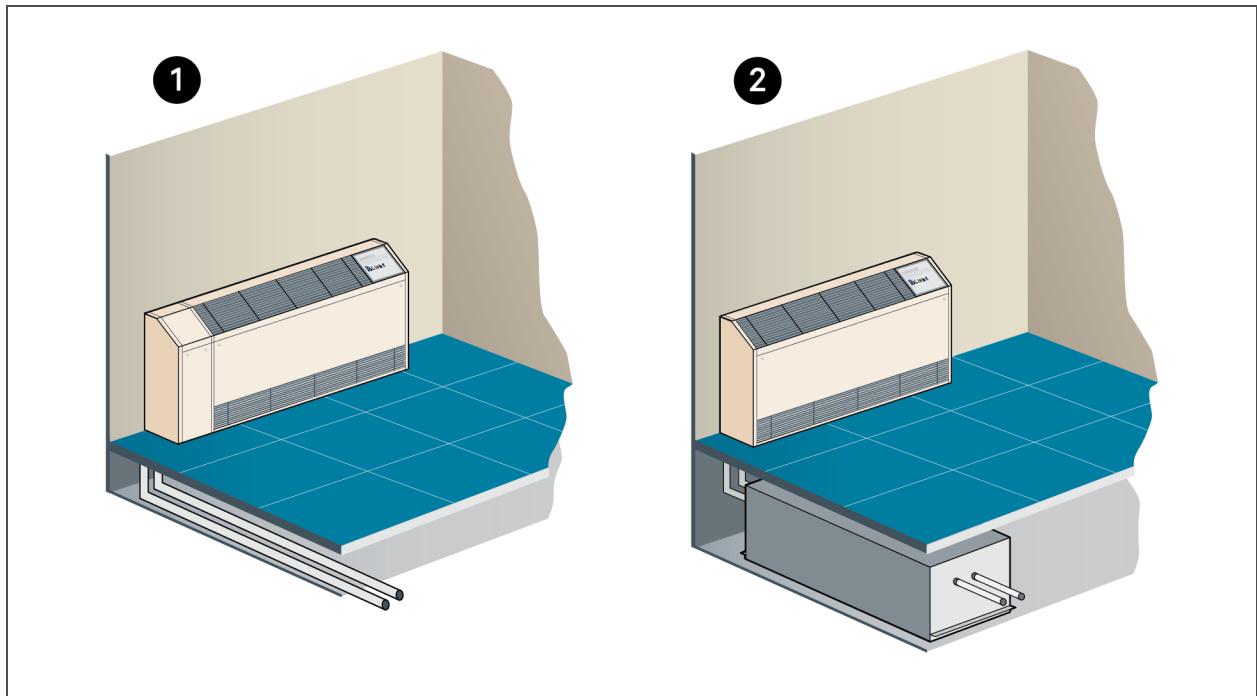

Item	Description
1	Water/Glycol cooled with close coupled condensing unit conveniently needs only a single power supply and water supply connection installed.
2	Water/Glycol cooled with remote, indoor condensing unit that installs under the raised floor or above the dropped ceiling.

Figure 2.3 Chilled Water Units

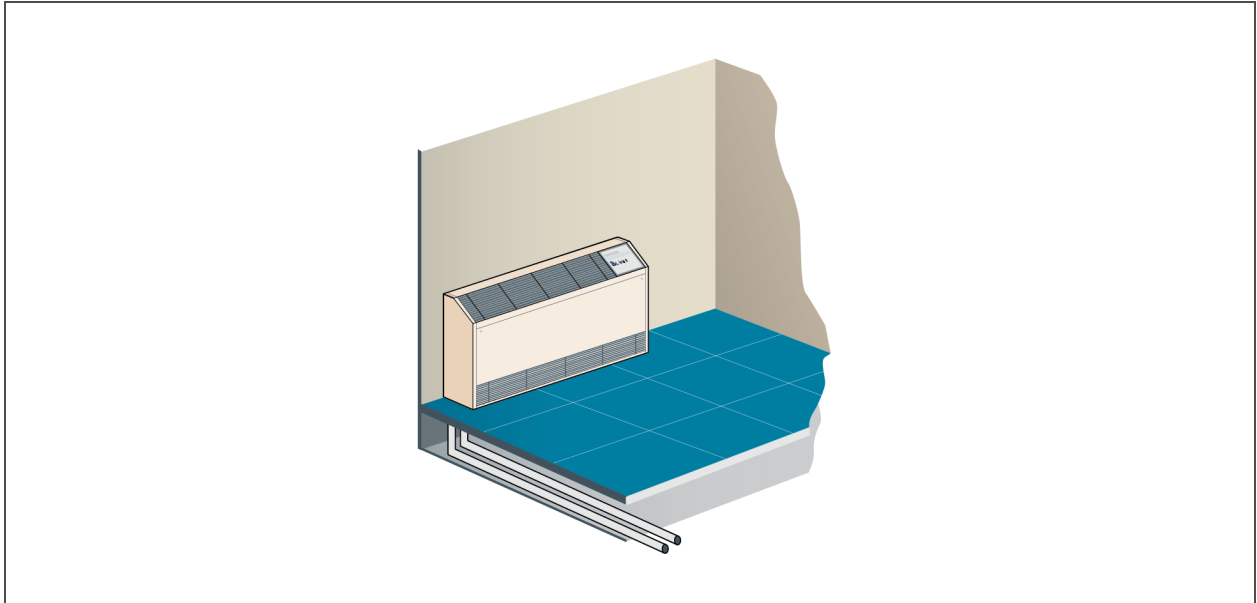

Item	Description
1	Chilled water cooled connects quickly and easily to a chilled water loop for ease of installation.

3 SITE PREPARATION AND EQUIPMENT HANDLING

NOTE: Before installing unit, determine whether any building alterations are required to run piping, wiring and ductwork. Follow all unit dimensional drawings and refer to the submittal engineering dimensional drawings of individual units for proper clearances.

3.1 Planning Dimensions

The unit dimensions are described in the submittal documents included in the [Submittal Drawings](#) on page 107.

The following table lists the relevant documents by number and title.

Table 3.1 Dimension Planning Drawings

Document Number	Title
Evaporators/Chilled Water Units	
DPN000262	Cabinet Dimensions, Evaporator/Chilled Water Unit
Indoor Condensing Units	
DPN004420	Cabinet Dimensions, Air Cooled units
DPN004421	Cabinet Dimensions, Water/Glycol Cooled units
DPN000269	Cabinet Dimensions, Close Coupled Water/Glycol Condensing Unit

3.2 Room Preparation

The room should be well insulated and must have a sealed vapor barrier. The vapor barrier in the ceiling and walls can be a polyethylene film. Paint on concrete walls and floors should be vapor resistant.

NOTE: The vapor barrier is the single most important requirement for maintaining environmental control in the conditioned area.

Outside or fresh air should be kept to a minimum when tight temperature and humidity control is required. Outside air adds to the site’s cooling, heating, dehumidifying and humidifying loads. We recommend keeping the outside air below 5% of the total air circulated in the computer room. Doors should be properly sealed to minimize leaks and should not contain ventilation grilles.

3.3 Application Limits

Table 3.2 Application Limits for Evaporator and Chilled Water Units

Input Voltage		Range of Return Air Conditions to the Unit*	
Minimum	Maximum	Dry Bulb Temperature	Relative Humidity
-5%	+10%	65 to 85°F (18 to 29°C)	20 to 80%
*The unit will operate at these conditions, but it will not control to these condition extremes.			

Table 3.3 Application Limits for Indoor and Outdoor Air Cooled Condensing Unit

Input Voltage		Condensing Unit Type	Entering Dry Bulb Air Temperature	
Minimum	Maximum		Minimum	Maximum
-5%	+10%	Outdoor prop fan condensing unit	-30°F (-34°C)	115°F (48°C) standard ambient unit* 125°F (52°C) high ambient unit*
-5%	+10%	Indoor air cooled condensing unit	-30°F (-34°C)	115°F (48°C)

*Unit capacity ratings are stated for 95°F (35°C) for standard units and 105°F (41°C) for PFH high ambient units. Exceeding these rating points by 20°F (11°C) will result in lower cooling capacities, but will not damage the equipment.

Table 3.4 Application Limits for Indoor Water/Glycol Cooled Condensing Unit

Input Voltage		Condensing Unit Type	Entering Fluid Temperature	
Minimum	Maximum		Minimum	Maximum
-5%	+10%		65°F (18°C)*	115°F (46°C)

*Operation below 65°F (18°C) may result in fluid noise and reduced valve life.

3.4 Location Considerations

When determining installation locations, consider that these units contain water and that water leaks from ceiling mounted condensing units can cause damage to sensitive equipment and furniture below.

NOTICE

Risk of leaking water/glycol. Can cause equipment and building damage.

Improper installation, application, and service practices can result in water leakage from the unit. Do not mount this unit over equipment and furniture that can be damaged by leaking water. Install a water-tight drain pan with a drain connection under the cooling unit and the ceiling mounted water/glycol condensing unit. Route the drain line to a frequently used maintenance sink so that running water can be observed and reported in a timely manner. Post a sign to alert people to report water flowing from the secondary drain pan. We recommend installing monitored leak detection equipment for the unit and supply lines and in the secondary drain pan. Check drain lines periodically for leaks, sediment buildup, obstructions, kinks and/or damage and verify that they are free running.

3.4.1 Location Considerations for Evaporator, Indoor Condensing and Chilled Water Units

The system can be installed in several ways. However, you should always mount the evaporator on a wall in the equipment room.

- For an air cooled system with an indoor condensing unit, the condensing unit may be installed near the evaporator to minimize piping, or near the outside wall to minimize air duct work.
- For water/glycol cooled systems, a DMC condensing unit may be close coupled with the evaporator or a remote MCD indoor condensing unit may be installed above the ceiling or below a raised floor.

Refer to [Refrigerant Line Sizes and Equivalent Lengths](#) on page 44 for maximum refrigerant line lengths.

Do not install units in areas where normal unit operating sound may disturb the working environment.

When installing an air cooled or water/glycol cooled unit inside a space, ensure that national and local codes are met for refrigerant concentration limits that might vary with building type and use.

Try to locate the evaporator in an unobstructed floor space to facilitate service. Avoid locations in confined areas that affect the air flow pattern and result in short cooling cycles, downdrafts and air noise. **Figure 3.1** below, shows location recommendations. Avoid locating the unit in an alcove or at the extreme end of a long, narrow room. Avoid installing multiple units close to each other, which can result in crossing air patterns, uneven loads and competing operating modes. Do not attach additional devices (such as smoke detectors, etc.) to the cabinet. Doing so interferes with routine maintenance and service.

Figure 3.1 Proper Location in the Room

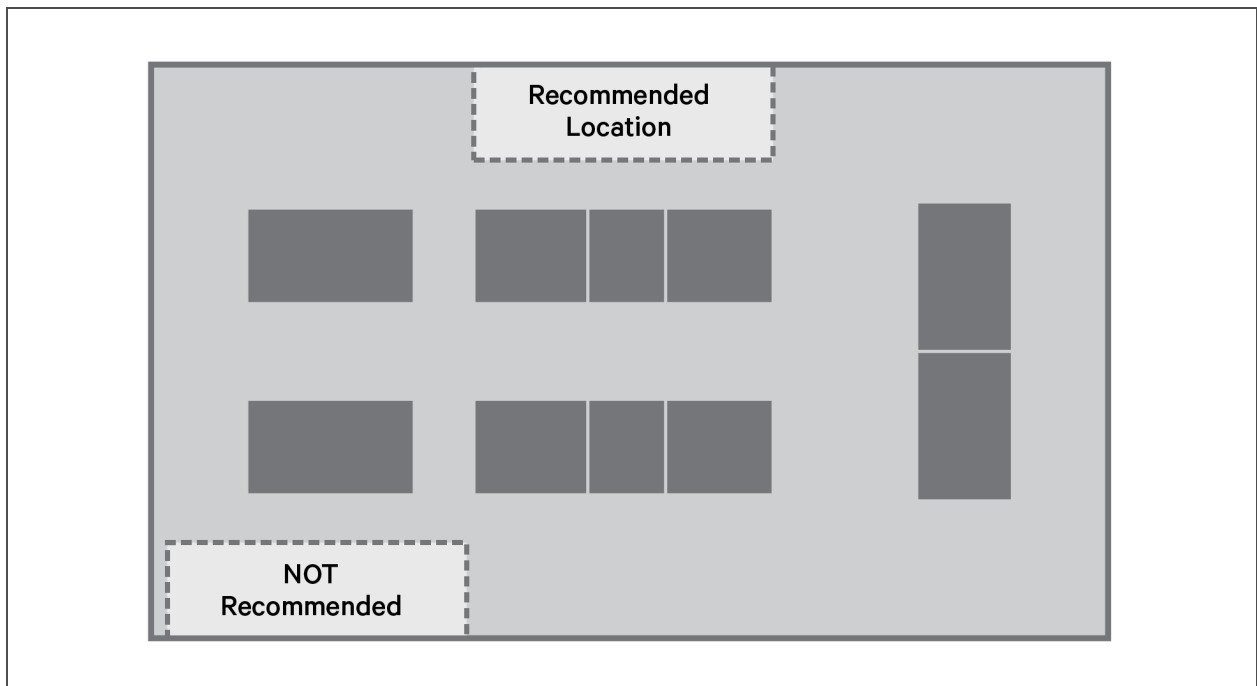

3.4.2 Location Considerations for an Outdoor Condensing Unit

For an air cooled system using an outdoor condensing unit, the condensing unit may be mounted on the roof or remotely in any outdoor area.

Observe the following when planning the installation of the outdoor unit:

- To ensure a satisfactory air supply, locate air cooled condensing units in an environment with clear air, away from loose dirt and foreign matter that may clog the coil.
- Condensing units must not be located in the vicinity of steam, hot air, or fume exhausts or closer than 18 inches from a wall, obstruction, or adjacent unit.
- Avoid areas where heavy snow will accumulate at air inlet and discharge locations.
- The condensing unit should be located for maximum security and maintenance accessibility. Avoid ground level sites with public access. Install a solid base, capable of supporting the weight of the condensing unit.
- The base should be at least 2 in. (51 mm) higher than the surrounding grade and 2 in. (51 mm) larger than the dimensions of the condensing unit base. For snowy areas, a base of sufficient height to clear snow accumulation must be installed.
- Securely attach the unit to the base using the holes provided in the unit mounting rails to prevent unit movement that might stress refrigerant piping and electrical wiring.

Before beginning, refer to [Piping and Refrigerant Requirements](#) on page 37 for unit placement, piping guidelines, and refrigerant charge requirements for your system.

The condensing unit must be located within the maximum distance from the evaporator using the evaporator guidelines listed in [Piping when Condensing Unit is Above or Below Evaporator](#) on page 43.

3.5 Unit Weights

Table 3.5 Evaporator and Condensing Unit weights

Model Number		lb. (kg)
60Hz	50Hz	
Evaporator Section		
DME020E	—	230 (104)
DME027E	—	330 (150)
DME037E	DME037E	365 (166)
DME044C	DME044C	365 (166)
Outdoor, Propeller Fan Condensing Unit		
PFH020A	—	200 (91)
PFH027A	—	200 (91)
PFH037A	PFH036A	241 (109)
Indoor, Centrifugal Fan Condensing Unit		
MCD24A	—	230 (104)
MCD36A	MCD35A	240 (109)
Water/Glycol Cooled Condensing Unit		
MCD26W	—	175 (79)
MCD38W	MCD37W	220 (100)
Close Coupled Water/Glycol Condensing Unit		
DMC022WG	—	170 (77)
DMC029WG	—	170 (77)
DMC040WG	—	170 (77)

3.6 Equipment Inspection and Handling



CAUTION: Risk of contact with sharp edges, splinters, and exposed fasteners. Can cause injury. Only properly trained and qualified personnel wearing appropriate, OSHA approved PPE should attempt to move, lift, remove packaging from or prepare the unit for installation.

Do not un-crate the equipment until it is close to its final location. All required assemblies are banded and shipped in corrugated containers. If any damage is discovered when the unit is un-crated, report it to the shipper immediately. If any concealed damage is later discovered, report it to the shipper and to your Vertiv representative.

This page intentionally left blank

4 INSTALLATION

Refer to the appropriate installation procedures depending the configuration and options of your Liebert® DataMate Thermal Management System.

4.1 Installing Wall Mounted Evaporators and Chilled Water Units



WARNING! Risk of unit falling off of the wall. Can cause building and equipment damage and serious injury. A licensed professional structural engineer should evaluate the wall to determine if the unit may be safely mounted on the wall and determine the type and size of fasteners required to support the weight of the unit during all phases of operation because some vibration may occur during start, stop, and operation cycles. The wall may need to be reinforced to support the maximum load of the unit. See **Table 3.5** on page 21, for unit weights.

Unlatch the front cabinet door and remove the screws that secure the cabinet to the chassis. Lift off the cabinet. Eight keyholes (0.50 in. head, 0.22 in. slot) are provided on the back of the unit for mounting on the wall. The unit must be level.

4.1.1 Changing Air Flow Direction

The air discharge grille on the evaporator can be placed in one of three different positions: vertical, horizontal, or 45°.

To change the air flow direction:

1. Remove the front panel using quarter-turn fasteners.
2. Remove the cabinet by removing the four retaining screws, then lift off the cabinet.
3. Remove the left end panel.
4. Remove the grille by sliding it to the left end of the unit.
5. Rotate or invert the grille to change the air discharge direction.
6. Reverse steps 1 through 4, to re-assemble the unit.

4.2 Installing Outdoor Condensing Unit for Air Cooled Split Systems

Refer to the appropriate guidelines and drawings when installing an outdoor, condensing unit for an air cooled split system. See [Location Considerations for an Outdoor Condensing Unit](#) on page 20. Follow all applicable national and local building, electrical and plumbing codes.

4.3 Installing Ceiling Mounted Condensing Units



WARNING! Risk of ceiling collapse and heavy unit falling. Can cause building and equipment damage, serious injury or death. If using a ceiling mounted condensing unit, verify that the supporting roof structure is capable of supporting the weight of the unit(s) and the accessories. See **Table 3.5** on page 21, for the unit weights. Securely anchor the top ends of the suspension rods and verify that all nuts are tight.

NOTICE

Risk of leaking water/glycol. Can cause equipment and building damage.

Improper installation, application, and service practices can result in water leakage from the unit. Do not mount this unit over equipment and furniture that can be damaged by leaking water. Install a water-tight drain pan with a drain connection under the cooling unit and the ceiling mounted water/glycol condensing unit. Route the drain line to a frequently used maintenance sink so that running water can be observed and reported in a timely manner. Post a sign to alert people to report water flowing from the secondary drain pan. We recommend installing monitored leak detection equipment for the unit and supply lines and in the secondary drain pan. Check drain lines periodically for leaks, sediment buildup, obstructions, kinks and/or damage and verify that they are free running.

4.3.1 Installing Suspension Rods and Mounting Ceiling Units

Refer to the [Location Considerations](#) on page 18 before beginning installation. These instructions apply to indoor air cooled and remote indoor water/glycol condensing units.

NOTE: Follow all national and local building, electrical, and plumbing codes.

- The ceiling and ceiling supports of existing buildings may require reinforcements.
- Four 3/8-in.-16 TPI threaded suspension rods are required and field supplied.
- The factory supplied 3/8-in. 16 TPI hardware kit includes the remaining installation hardware.
- Recommended clearance between ceiling grids and building structural members is the unit's height plus 3 in. (76 mm).

To install the suspension rods:

1. Install the four field supplied 3/8-in. 16 TPI threaded rods by suspending them from suitable building structural members so that they will align with the four mounting locations on the unit base.
2. Securely anchor the top ends of the suspension rods with field supplied nuts.
3. Make sure all nuts are tight and locked.

To lift and install the unit on the rods:

1. Using a suitable lifting device that is rated for the weight of the unit (see [Unit Weights](#) on page 21), raise the unit and pass the threaded rods through the four mounting locations in the unit base.
2. Attach the threaded rods to the flanges using the plain nuts to hold the unit in place as shown in **Figure 4.1** on the facing page.
3. Slowly lower the lifting device, making sure that the rods securely hold the weight of the unit.
4. Adjust the plain nuts to distribute the weight of the unit evenly by the rods, making sure that the unit does not rest on the ceiling grid and that the unit is level.
5. Use the Nylock nuts to jam the plain nuts in place as shown in **Figure 4.1** on the facing page.

Figure 4.1 Installing Threaded Rods and Hardware of Ceiling Mounted Units

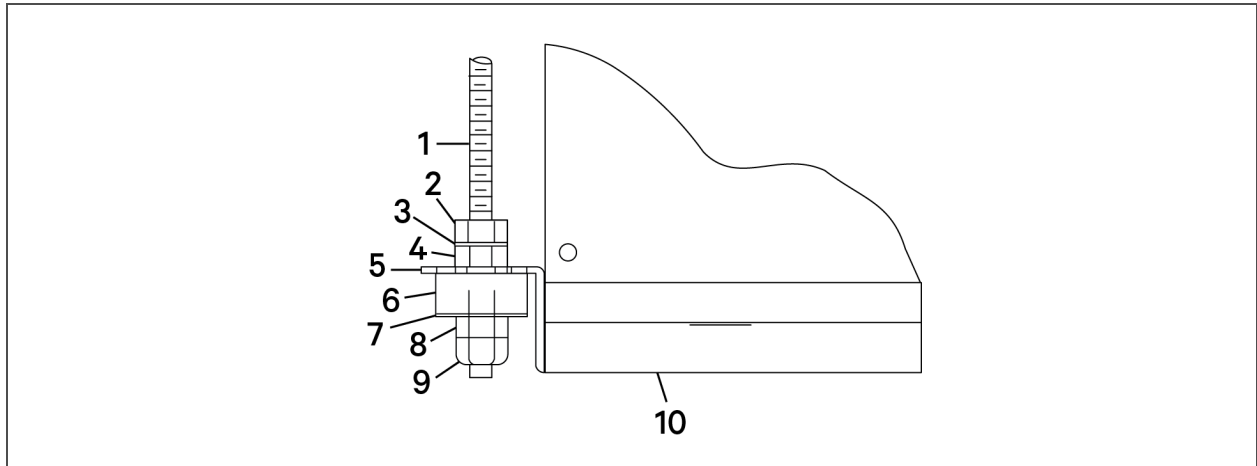

Item	Description	Item	Description
1	3/8-in. threaded rod, field-supplied	7	3/8-in. fender washer
2	3/8-in. hex nut	8	3/8-in. hex nut
3	3/8-in. washer	9	3/8-in. Nylock locking nut
4	Sleeve	10	Unit base pan (reference)
5	Bracket on unit		
6	Isolator		

4.3.2 Guidelines for Ducted Systems

Observe the following for all ductwork:

- Ductwork should be fabricated and installed in accordance with local and national codes.
- Use flexible ductwork or nonflammable cloth collars to attach ductwork to the unit and to control vibration transmission to the building.
- Attach the ductwork to the unit using the flanges provided.
- Locate the unit and ductwork so that the discharge air does not short circuit to the return air inlet.
- Avoid directing the hot exhaust air toward adjacent doors or windows.
- Ductwork that runs through a conditioned space or is exposed to areas where condensation may occur must be insulated. Insulation of ductwork is vital to prevent condensation during the cooling cycle.
- The use of a vapor barrier is required to prevent absorption of moisture from the surrounding air into the insulation.
- If the return air duct is short or if noise is likely to be a problem, sound absorbing insulation should be used inside the duct.
- Ductwork should be suspended using flexible hangers. Ductwork should not be fastened directly to the building structure.
- For multiple unit installations, space the units so that the hot condensing unit exhaust air is not directed toward the air inlet of an adjacent unit.

Consider the following in specific applications of ductwork to condensing units:

- **In applications where the ceiling plenum is used as the heat rejection domain**, the discharge air must be directed away from the condensing unit air inlet and a screen must be added to the end of the discharge duct to protect service personnel. Locate the air discharge a minimum of 4 ft. from an adjacent wall. Failure to do so may result in reduced air flow and poor system performance.
- **If the condensing unit draws air from the outside of the building**, rain hoods must be installed. Hood intake and ductwork cross-sectional area dimensions should be equal to or greater than the area of the condensing unit intake flange. In addition, install a triple layer bird screen over rain hood openings to eliminate the possibility of insects, birds, water, or debris entering the unit. Avoid directing the hot exhaust air toward adjacent doors or windows.

Table 4.1 Indoor Condensing Unit Airflow, CFM at 0.5 iwg (124 PA) esp

2 Ton	3 Ton
1000	1430

4.4 Close Coupled Installations for Integral Water/Glycol Condensing Units

You can mount the evaporator and indoor, DMC water/glycol cooled condensing unit directly next to each other, close coupled.

The DMC condensing unit attaches to the left side of the evaporator chassis. For connection sizes, see **Table 5.2** on page 37, for the appropriate submittal drawing for your unit. For condensing unit fluid requirements, see [Water/Glycol Loop Piping](#) on page 40.

To install the close coupled condensing unit:

1. You will need access to the rear of the unit, so make sure that the evaporator and condensing unit are moved away from the wall for the installation.
2. On the evaporator, open the quarter-turn fasteners and remove the front access panel, then remove the four screws from the front of the evaporator, see **Figure 4.2** below.

Figure 4.2 Remove Front Access Cover and Evaporator Screws

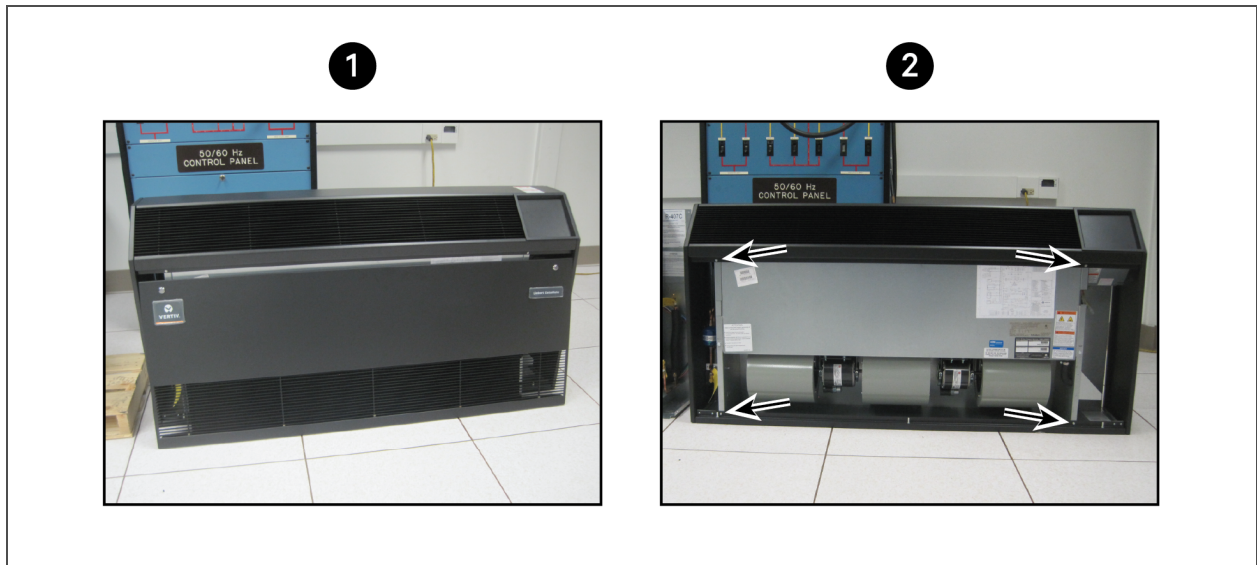

Item	Description
1	Remove front access panel.
2	Remove 4 screws.

3. Remove the evaporator's panel assembly by lifting up and away from the unit, see **Figure 4.3** on the next page.

Figure 4.3 Remove Evaporator Panel Assembly



4. On the left end of the evaporator, remove the six screws that fasten the chassis extension to the evaporator:
- Two screws from the inside, bottom as shown in **Figure 4.4** below.
 - Four screws from the back side.
 - Save the six screws to use when attaching the condensing unit.

NOTE: This piece is not used with the close coupled units and may be recycled.

Figure 4.4 Remove the Chassis Extension

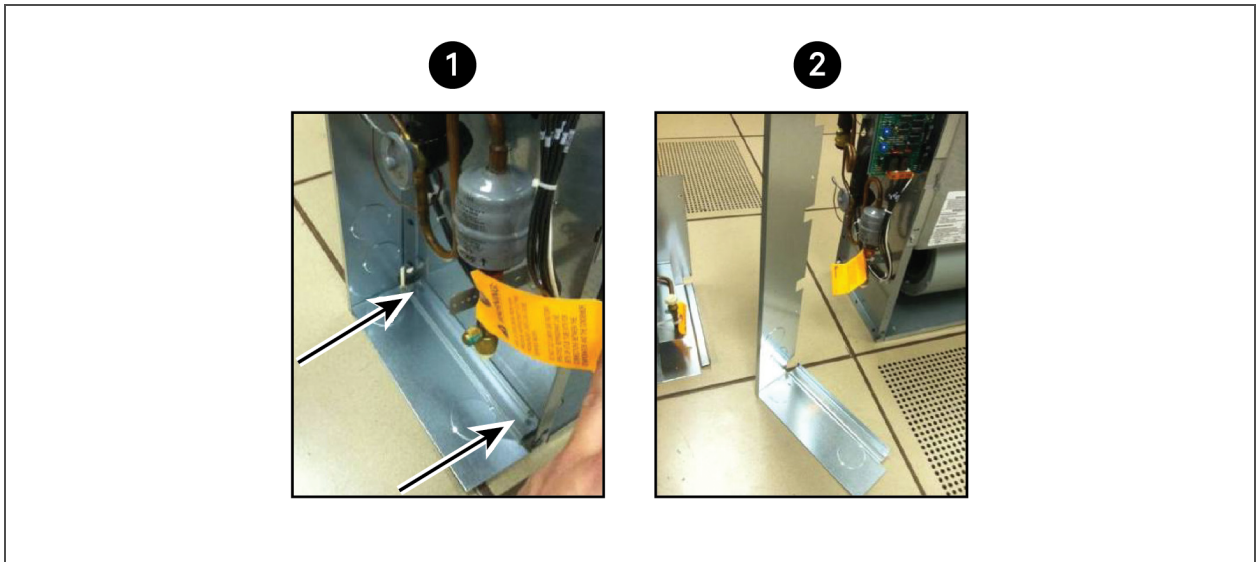

Item	Description
1	2 screws at bottom (4 more on back of unit)
2	Chassis extension (not used in close coupling, recycle)

5. On the evaporator panel assembly:
 - Remove the cutout from the bottom-left side, see **Figure 4.5** below.
 - Remove the support bracket inside the bottom-left side, see **Figure 4.6** below.

Figure 4.5 Cutout to Remove from Panel Assembly

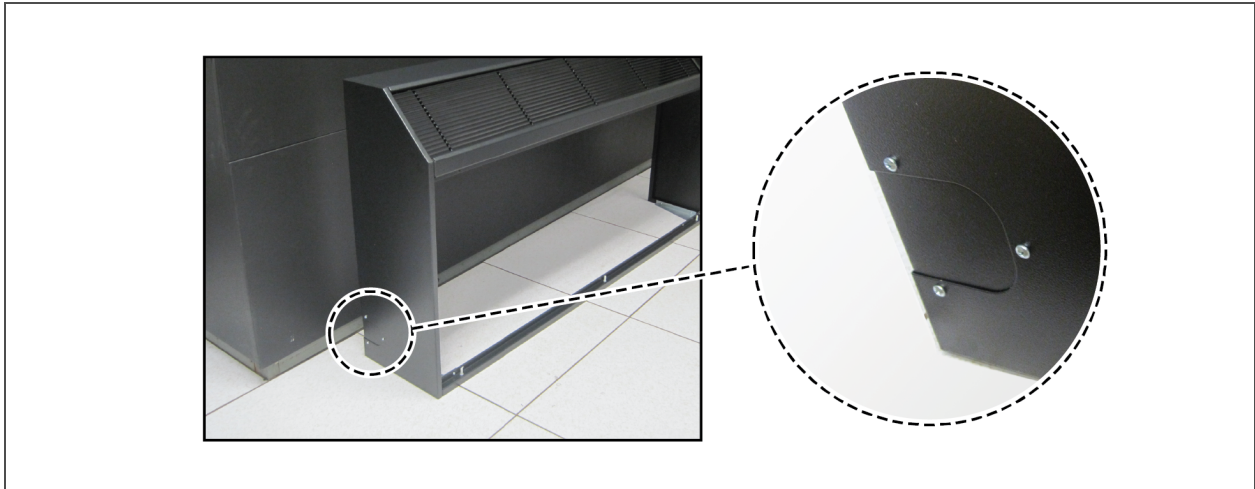

Figure 4.6 Support Bracket to Remove from Panel Assembly



6. On the condensing unit, open the quarter-turn fasteners and remove the front access panel, see **Figure 4.7** below.

Figure 4.7 Remove Front Access Panel from Condensing Unit



7. Prepare to cut the refrigerant piping:
 - Carefully remove the insulation from the suction line, see **Figure 4.8** below.
 - Slide the units together, and mark the connection point.

! CAUTION: Risk of explosion from high pressure inert gases. Cutting pressurized lines can cause serious injury. Do not cut the liquid and suction lines until nitrogen has been purged.

Figure 4.8 Mark the Pipes to Cut for Connection

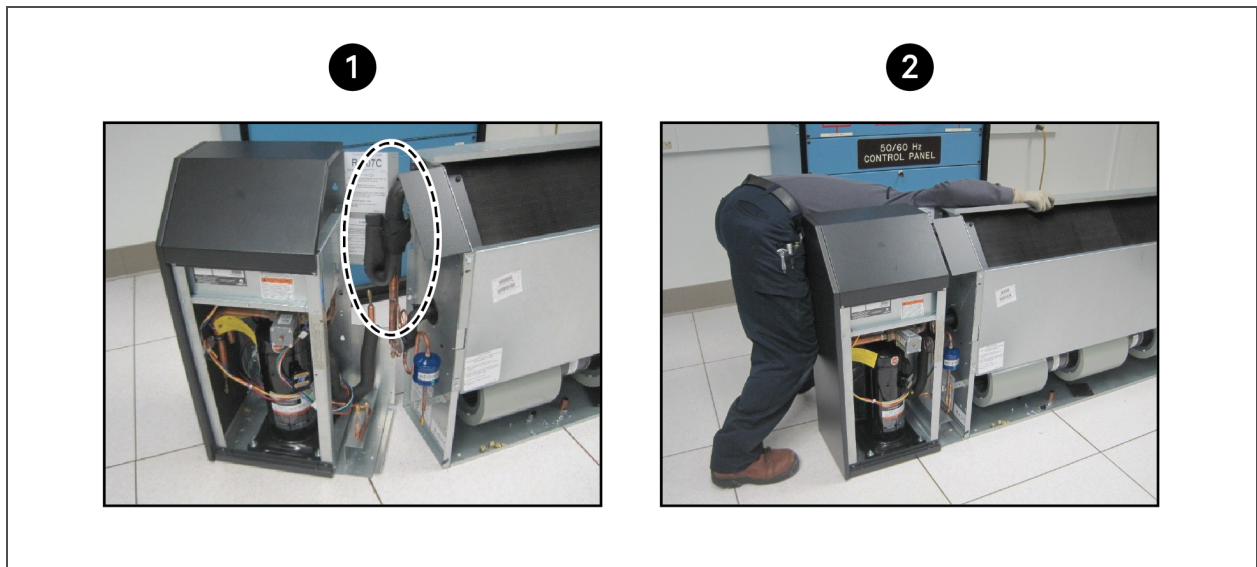

Item	Description
1	Insulation carefully removed.
2	Units together to mark pipes.

8. Slide the units apart.
9. Purge the nitrogen in both evaporator and condensing unit sections.

NOTE: Make sure that you plan enough time to complete steps 10 to 13, and all the steps in [Connecting the Close Coupled Refrigerant Circuit](#) on the facing page, on the same day. This is critical to keep moisture out of the system.

10. Use a tube cutter to cut the pipes, then install tubing sleeves on the suction and liquid lines, see [Figure 4.9](#) below.

Figure 4.9 Pipe Cut with Tubing Sleeve Installed



11. Slide the units together, and install the four screws removed in step 4 into the rear of the units to join the chassis, see [Figure 4.10](#) on the facing page.
12. From the front in the blower section, install the two screws removed in step 4 into the clearance holes in the evaporator section and make sure they grab the bite holes in the condensing unit, see [Figure 4.10](#) on the facing page.
13. Proceed to [Connecting the Close Coupled Refrigerant Circuit](#) on the facing page.

Figure 4.10 Fastening the Evaporator and Condensing Unit Chassis Together

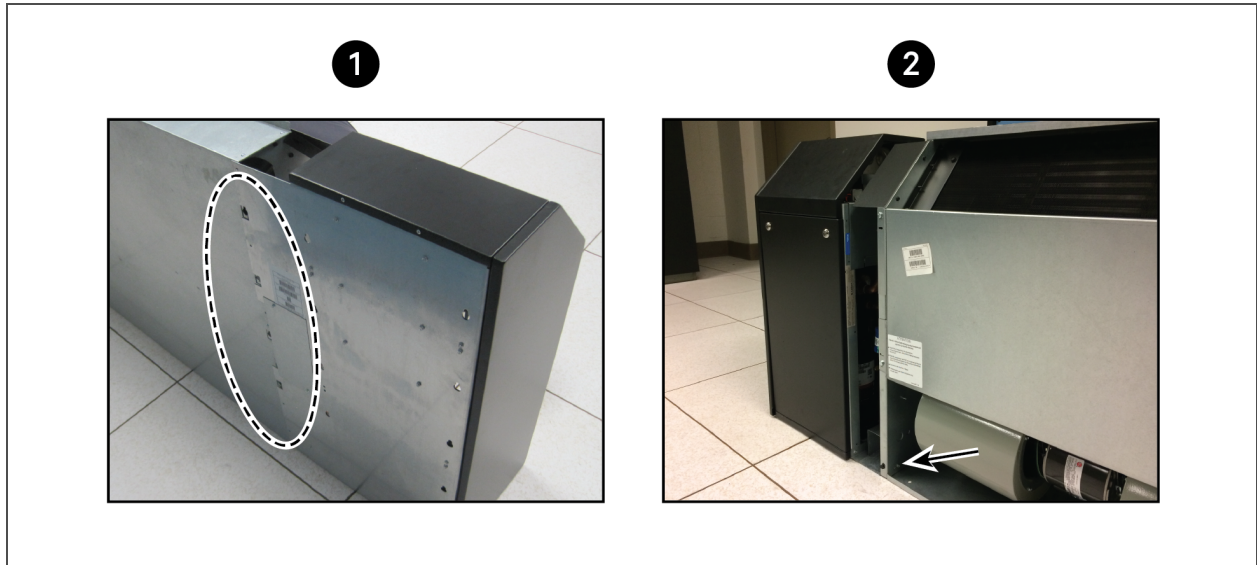

Item	Description
1	Screw locations on rear of unit.
2	Screws from blower section to condenser section.

4.4.1 Connecting the Close Coupled Refrigerant Circuit

1. Access the liquid line from the front and suction line through front and rear of unit, see **Figure 4.11** on the next page. Loosen or remove the piping brackets/clamps as necessary to connect the lines.
2. Remove the clamps, and slide the tubing sleeve into place making sure that the connection point is in the middle of the sleeve for both the liquid line and suction line connections
3. Use a brazing blanket to protect the expansion valve capillary tube and the equalizer line, and move wiring away from the brazing area.

IMPORTANT! Use good brazing practices and flowing nitrogen during brazing. See [Field Fabricated Refrigeration Piping](#) on page 46, for detailed steps.

4. Braze the liquid line from the front of the unit.
5. Braze the suction line from the front and rear of the unit.
6. Replace the clamps and replace the suction line insulation.

Figure 4.11 Liquid Line and Suction Line Connections

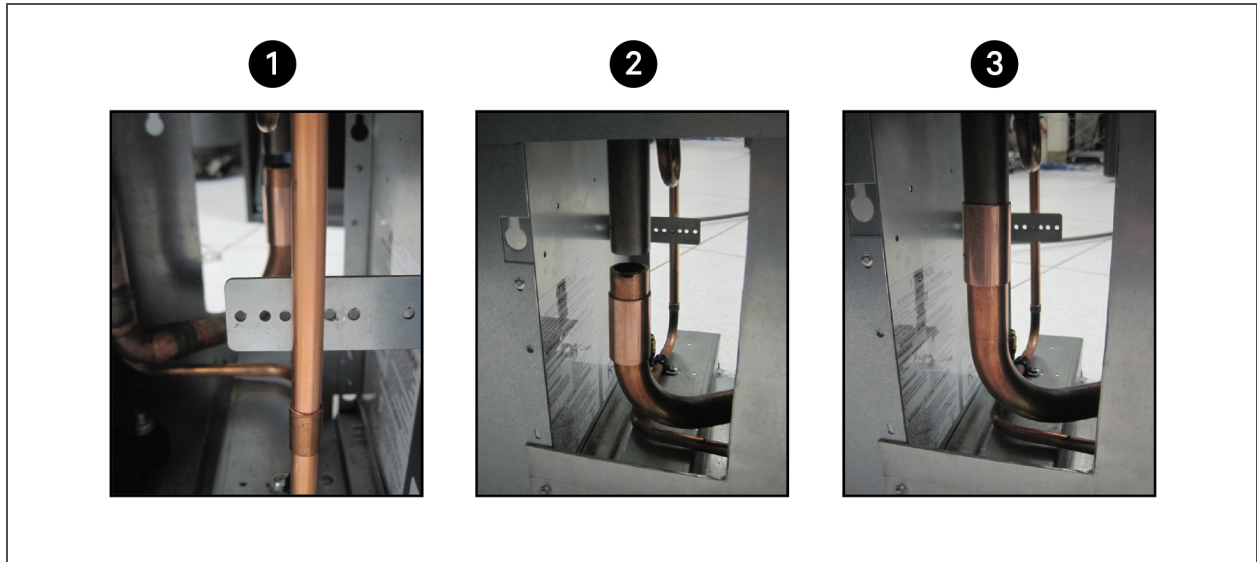

Item	Description
1	Liquid connection with sleeve in place (front panel access)
2	Suction connection (rear panel access)
3	Sleeve in place on suction connection

4.4.2 Connecting the Close Coupled Electrical Wiring



WARNING! Arc flash and electric shock hazard. Open all local and remote electric power supply disconnect switches, verify with a voltmeter that power is Off and wear appropriate, OSHA approved personal protective equipment (PPE) per NFPA 70E before working within the electric control enclosure. Failure to comply can cause serious injury or death. Customer must provide earth ground to unit, per NEC, CEC, and local codes, as applicable. Before proceeding with installation, read all instructions, verify that all the parts are included and check the nameplate to be sure the voltage matches available utility power. The Liebert® controller does not isolate power from the unit, even in the Unit Off mode. Some internal components require and receive power even during the Unit Off mode of the controller. The only way to ensure that there is NO voltage inside the unit is to install and open a remote disconnect switch. Refer to unit electrical schematic. Follow all local codes.

When close coupling the DataMate evaporator with the integral, water/glycol condensing unit, a single power feed connection is made at the condensing unit. The condensing unit ships with a power/control wire harness to internally connect the two units.

1. Refer to [Electrical Connection Requirements](#) on page 55, and [Water/Glycol Cooled Unit Control Connections](#) on page 57, for input power and control wiring requirements before making the electrical connections.
2. Route the wiring harness from the condensing unit along the top of the evaporator as shown in [Figure 4.12](#) below.
3. Refer to the unit electrical schematic and to DPN000271 included in the [Submittal Drawings](#) on page 107 to make the appropriate connections.
4. If the integral condensing unit is used in a glycol loop, it must be connected to the drycooler. There are terminals on the condensing unit electric box for Class 1 wiring to the heat rejection equipment.

Figure 4.12 Power/Control Wire Harness Routing

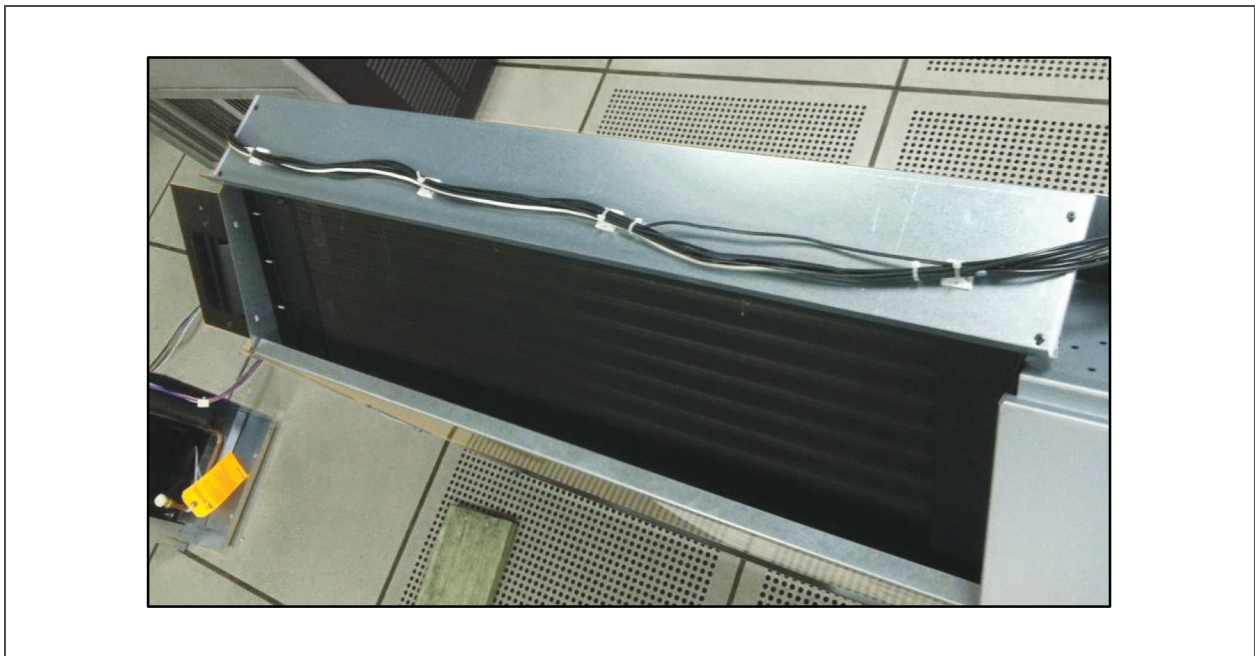

4.4.3 Final Installation Steps for Close Coupled Units

1. Refer to [Installing Wall Mounted Evaporators and Chilled Water Units](#) on page 23, to install the close coupled unit on the wall, if necessary.
2. Refer to [Fluid Piping Required](#) on page 38, and the appropriate piping connection drawings included in the [Submittal Drawings](#) on page 107, to connect the heat rejection equipment and other fluid piping connections, as necessary.
3. Refer to [Evacuation and Leak Testing Water/Glycol Cooled Systems](#) on page 50, and [Charging Water/Glycol Cooled Systems](#) on page 52, to charge the system with refrigerant.
4. Replace the evaporator panel assembly and secure it with the four screws on the front of the evaporator.
5. Replace the front access panels on the evaporator and condensing unit, and secure the panels with the quarter-turn fasteners.

5 PIPING AND REFRIGERANT REQUIREMENTS

All field supplied refrigeration piping to the unit must be sweat copper. Use prevailing good piping practices for all connections which include brazing copper pipes using a brazing alloy of minimum temperature of 1350 °F (732 °C) and adhering to all local codes. All other fluid connections to units, with the exception of the condensate drain, are sweat copper. Factory installed piping brackets must not be removed. Field installed piping must be installed in accordance with local codes and must be properly assembled, supported, isolated, and insulated. Avoid piping runs through noise sensitive areas, such as office walls and conference rooms.

The following pipe connections are required:

- A drain line from the evaporator coil drain pan.
- A drain line from the optional humidifier (if applicable).
- A drain line from the optional condensate pump (if applicable).
- A water supply line to the optional humidifier (if applicable).
- On air cooled and water/glycol cooled systems: refrigerant piping connections between the evaporator unit and the condensing unit.
- On chilled water systems: connections to the building chilled water source. See [Chilled Water Loop Piping](#) on page 39, for additional requirements.
- On water/glycol systems: connections to a water or glycol loop. See [Water/Glycol Loop Piping](#) on page 40, for additional requirements.

Refer to specific text and detailed diagrams in this manual for other unit specific piping requirements.

The pipe connection locations, piping general arrangement, and schematics are described in the submittal documents included in the [Submittal Drawings](#) on page 107.

The following tables list the relevant documents by number and title.

Table 5.1 Piping General Arrangement Drawings

Document Number	Title
DPN004406	Piping, Air Cooled Models
DPN004405	Piping, Split System Water/Glycol Models
DPN004403	Piping, Close Coupled Water/Glycol and Chilled Water Models

Table 5.2 Piping Connection Drawings

Document Number	Title
Evaporator and Chilled Water Units	
DPN004306	Piping Connections, Chilled Water Units
Split System Indoor Condensing Units	
DPN004420	Piping Connections, Air Cooled Condensing Unit
DPN004421	Piping Connections, Remote Water/Glycol Cooled Condensing Unit
DPN004309	Piping Connections, Close Coupled Water/Glycol Cooled Units

5.1 Fluid Piping Required

5.1.1 Evaporator Drain Line Installation Requirements

A 3/4 in. (19 mm) OD hose barb connection is provided for the evaporator coil condensate drain.

Observe the following requirements when installing and routing the drain line:

- The drain line must be located so it will not be exposed to freezing temperatures.
- The drain should be the full size of the drain connection.
- Pitch the drain line per local and national codes.

NOTE: The drain line must be trapped outside the unit.

5.1.2 Humidifier Drain Line Installation Requirements

On units with an optional humidifier, a 1/2 in. (13 mm) OD hose barb connection is provided for the steam generating humidifier canister.

Observe the following requirements when installing and routing the drain line:

- The drain should be the full size of the drain connection.
- Pitch the drain line per local and national codes.

NOTE: The drain line must be trapped outside the unit. This line may contain boiling water. User copper or other suitable material for the drain line.

5.1.3 Condensate Drain Pump Kit



WARNING! Risk of electric shock. Can cause equipment damage, injury, or death. Open all local and remote electric power supply disconnect switches and verify with a voltmeter that power is off before working within any electric connection enclosures. Service and maintenance work must be performed only by properly trained and qualified personnel and in accordance with applicable regulations and manufacturers' specifications. Opening or removing the covers to any equipment may expose personnel to lethal voltages within the unit even when it is apparently not operating and the input wiring is disconnected from the electrical source.

The optional condensate pump kit is required when the evaporator is installed below the level of the gravity fed drain line. The condensate pump is field installed inside the evaporator unit. The pump kit includes a check valve, sump, sump level sensor, controls, fittings, and complete instructions.

Table 5.3 Condensate Drain Pump Drawings

Document Number	Title
DPN004306	Field Installed Pump Connection

To install the condensate drain pump:

1. Refer to the instructions and drawings supplied with the pump.
2. Disconnect all power to the unit, and remove the evaporator housing.
3. Make the following piping connections, see **Table 5.3** above:
 - Unit drain pan
 - Unit's humidifier drain (if applicable)

- Output to field provided/field installed drain line
4. With the wiring harness, make the following electrical connections to :
 - Connect yellow electric leads L1 and L2 to the line voltage terminal block in the cooling unit.
 - Connect the green ground lead to the lug near the terminal block.
 - Connect red wires from the auxiliary pump contacts to terminals TB6-4 and TB6-5 to shut down unit at the occurrence of a high water condition in the pump.
 5. Tighten all connections and, before installing the housing, run the unit to make sure the pump works properly. Operate the pump and check the drain line and discharge line for leaks. Correct as needed.

NOTE: Schedule periodic inspection of the piping connections. Clean the pump's sump at the same time you wash the evaporator air filter. We recommend at least monthly cleaning.

5.1.4 Water Supply Line to the Humidifier

Units supplied with the optional humidifier package have a 1/4-in. (6.2-mm) tube compression at the water supply inlet.

- The supply pressure range is 10 psig to 150 psig (69 kPag to 1034 kPag).
- The required flow rate is 1 gpm (3.8 lpm).
- Install a shut-off valve in the supply line to isolate the humidifier for maintenance.

5.1.5 Chilled Water Loop Piping

NOTICE

Risk of piping system corrosion and freezing fluids. Can cause leaks resulting in equipment and very expensive building damage. Cooling coils and piping systems are at high risk of freezing and premature corrosion. Fluids in these systems must contain the proper antifreeze and inhibitors to prevent freezing and premature coil and piping corrosion. The water or water/glycol solution must be analyzed by a competent local water treatment specialist before start-up to establish the inhibitor and antifreeze solution requirement and at regularly scheduled intervals throughout the life of the system to determine the pattern of inhibitor depletion.

The complexity of water/glycol solution condition problems and the variations of required treatment programs make it extremely important to obtain the advice of a competent and experienced water treatment specialist and follow a regularly scheduled coolant fluid system maintenance program.

Water chemistry varies greatly by location, as do the required additives, called inhibitors, that reduce the corrosive effect of the fluids on the piping systems and components. The chemistry of the water used must be considered, because water from some sources may contain corrosive elements that reduce the effectiveness of the inhibited formulation. Sediment deposits prevent the formation of a protective oxide layer on the inside of the coolant system components and piping. The water/coolant fluid must be treated and circulating through the system continuously to prevent the buildup of sediment deposits and or growth of sulfate reducing bacteria.

Proper inhibitor maintenance must be performed in order to prevent corrosion of the system. Consult glycol manufacturer for testing and maintenance of inhibitors.

Commercial ethylene glycol, when pure, is generally less corrosive to the common metals of construction than water itself. It will, however, assume the corrosivity of the water from which it is prepared and may become increasingly corrosive with use if not properly inhibited.

We recommend installing a monitored fluid detection system that is wired to activate the automatic closure of field installed coolant fluid supply and return shut-off valves to reduce the amount of coolant fluid leakage and consequential equipment and building damage. The shut-off valves must be sized to close off against the maximum coolant fluid system pressure in case of a catastrophic fluid leak.

NOTICE

Risk of no flow condition. Can cause equipment damage.

Do not leave the water/coolant fluid supply circuit in a no flow condition. Idle fluid allows the collection of sediment that prevents the formation of a protective oxide layer on the inside of tubes. Keep unit switched On and water/coolant fluid supply circuit system operating continuously.

See **Table 5.4** below, for the chilled water loop requirements.

Install manual service shut-off valves at the supply and return lines of each unit. These shut-off valves are used for routine service and for emergency isolation of the unit.

Refer to the appropriate piping general arrangement schematics for your system for the recommended, field installed hardware such as shut-off valves and hose bibs. See **Table 5.1** on page 37.

NOTE: Ambient conditions and the minimum supplied water temperature determines whether or not you should insulate the chilled water supply and return lines to prevent condensation on the lines.

Table 5.4 Requirements for Chilled Water Loop Installation

Minimum Recommended Water Temperature, °F (°C)	Standard Pressure Valve Design Pressure, Psig (Kpag)	Supply/Return Connection Sizes, in.
42 (5.5)	300 (2,068) with a maximum close off pressure of 60 psig (414 kPa)	7/8 O.D. Cu

5.1.6 Water/Glycol Loop Piping

NOTICE

Risk of frozen pipes and corrosion from improper coolant mixture. Can cause water leaks resulting in equipment and building damage.

When piping or the cooling unit may be exposed to freezing temperatures, charge the system with the proper percentage of glycol and water for the coldest design ambient temperature. Automotive antifreeze is unacceptable and must NOT be used in any glycol fluid system. Use only HVAC glycol solution that meets the requirements of recommended industry practices.

Do not use galvanized pipe.

Install manual service shut-off valves at the supply and return line to each unit. This permits routine service and emergency isolation of the unit. Refer to the appropriate submittal drawing for the piping connection sizes of your unit, see **Table 5.2** on page 37.

Refer to the appropriate piping general arrangement schematics for your system for the recommended, field installed hardware such as shut-off valves. See **Table 5.1** on page 37.

When the fluid quality is poor, we recommend installing a 16-20# mesh Y strainer filter in the supply line to extend the service life of the coaxial condensers. These filters must be easily replaced or cleaned.

The standard maximum fluid pressure is 150 psig (1034 kPa). For applications above this pressure, contact a Vertiv representative.

The water cooled system will operate in conjunction with a cooling tower or city water. The water/glycol cooled system will operate in conjunction with a cooling tower, city water, or drycooler.

NOTE: HVAC grade ethylene or propylene glycol should be used on glycol systems. Automotive antifreeze must not be used.

Water/Glycol Coolant Regulating Valve

Water/glycol cooled units include a coolant flow regulating valve that may require adjustment.

To adjust the valve:

1. Attach refrigeration gauges to the compressor discharge and suction lines.
2. Raise the head pressure by turning the adjusting screw clockwise.
3. Allow enough time between adjustments for the system to stabilize. Refer to recommended operating pressures in [Water/Glycol Loop Piping](#) on the previous page.
4. The coolant flow should stop when the refrigeration system is off for approximately 10 to 15 minutes. If the coolant continues to flow, the valve is improperly adjusted (head pressure is too low).
5. Flush the valve by inserting a screwdriver or similar tool under the two sides of the main spring and lifting. This opens the valve seat and flushes out any dirt particles,

5.2 Refrigerant Piping



WARNING! Risk of over-pressurization of the refrigeration system. Can cause piping rupture, explosive discharge of high pressure refrigerant, loss of refrigerant, environmental pollution, equipment damage, injury, or death. This unit contains fluids and gases under high pressure. Use extreme caution when charging the refrigerant system. Do not pressurize the system higher than the design pressure marked on the unit's nameplate. Relieve pressure before cutting into or making connections/disconnections to the piping system. Local building or plumbing codes may require installing a pressure relief device in the system.

Consult local building and plumbing codes for installation requirements of additional pressure relief devices when isolation valves are field installed. Do not isolate any refrigerant circuits from over-pressurization protection. The PFH and MCD condensing units include a factory installed pressure relief valve mounted on top of the receiver. The valve is rated for a maximum working pressure of 475 psig.

NOTICE

Risk of oil contamination with water. Can cause equipment damage.

Liebert® DataMate DX systems require the use of POE (polyolester) oil. POE oil absorbs water at a much faster rate when exposed to air than previously used oils. Because water is the enemy of a reliable refrigeration system, extreme care must be used when opening systems during installation or service. If water is absorbed into the POE oil, it will not be easily removed and will not be removed through the normal evacuation process. If the oil is too wet, it may require an oil change. POE oils also have a property that makes them act as a solvent in a refrigeration system. Maintaining system cleanliness is extremely important because the oil will tend to bring any foreign matter back to the compressor.

NOTICE

Risk of improper refrigerant charging. Can cause equipment damage.

Refrigerant charge must be weighed into compressorized systems before they are started.

Split systems require two refrigerant lines between the evaporator and the condensing unit:

- One insulated copper suction line
- One copper liquid line

Observe the following requirements for all field supplied refrigeration piping:

- All piping must be ACR type copper.
- For all piping connections, use prevailing good piping practices, which includes brazing copper pipes using a brazing alloy of a minimum temperature of 1350°F (732°C) and adhere to local codes.
- Factory installed piping brackets must not be removed.
- Piping must be installed in accordance with local codes and must be properly assembled, supported, isolated, and insulated.
- Use prevailing good refrigeration practices such as piping supports, leak testing, evacuation, dehydration, and charging of the refrigeration circuits.
- Isolate the refrigeration piping from the building with vibration isolating supports.
- Avoid piping runs through noise sensitive areas such as office walls and conference rooms.
- When sealing openings in walls and to reduce vibration transmission, use a soft, flexible material to pack around the tubes to prevent tube damage.
- When installing remote condensing units above the evaporator, the suction gas lines should be trapped at the evaporator. These traps will retain refrigerant oil in the off cycle. When the unit starts, oil in the traps is carried up the vertical risers and returns to the compressors.

5.2.1 Piping when Condensing Unit is Above or Below Evaporator

Refer to [Pipe Length and Condensing Unit Elevation Relative to Evaporator](#) below, for the maximum vertical rise/fall between condensing unit and evaporator.

When installing remote condensing units above the evaporator, trap the suction gas line at the evaporator as shown in **Figure 5.1** on the next page. This trap will retain refrigerant oil during the Off cycle. When the unit starts, oil in the trap is carried up the vertical riser and returns to the compressor. For rises over 25 ft. (7.6 m), trap every 20 ft. (6 m) or evenly divided.

When installing remote condensing units below the evaporator, trap the suction gas line with an inverted trap the height of the evaporator as shown in **Figure 5.1** on the next page. This prevents refrigerant migration to the compressor during Off cycles. The maximum recommended vertical level drop to condensing unit is 15 ft. (4.6 m).

Table 5.5 Pipe Length and Condensing Unit Elevation Relative to Evaporator

Nominal System Size, Ton	Maximum Equivalent Pipe Length, ft. (m)	Maximum Condensing Unit Level Above Evaporator, ft. (m)	Maximum Condensing Unit Level Below Evaporator, ft. (m)
1.5 and 2	150 (45)	40 (12)	15 (4.6)
3	150 (45)	50 (15)	15 (4.6)

Maximum recommended total equivalent pipe length is 150 ft. (46 m). Suction and liquid lines may require additional specialty items when vertical lines exceed 20 ft. (6 m) and/or condensing unit installation is more than 15 ft. (4.6 m) below the evaporator. Contact Vertiv Technical Support for assistance.

Figure 5.1 Refrigerant Piping Diagram when Condenser is Above or Below Evaporator

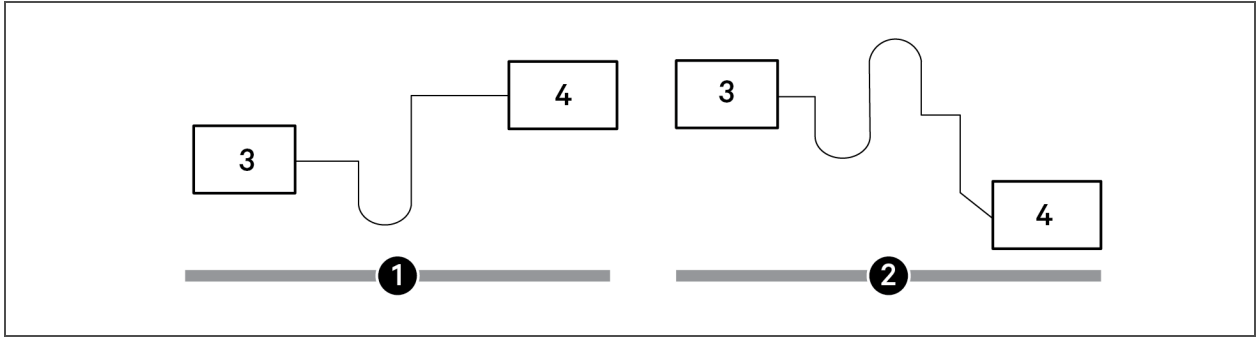

NOTE: Any horizontal pipe must be pitched down toward the condensing unit at a minimum rate of 1/2 in. (13 mm) per 10 ft. (3 m) to assure oil return to compressor.

Item	Description
1	Condensing unit above evaporator
2	Condensing unit below evaporator
3	Evaporator
4	Condensing unit

5.2.2 Refrigerant Line Sizes and Equivalent Lengths

The following tables list information required to field install the refrigerant piping for the system.

The pipe connection sizes for your equipment are included in the appropriate submittal documents included in the [Submittal Drawings](#) on page 107.

Table 5.6 Recommended Refrigerant Line Sizes, O.D. cu by Equivalent Length

Equivalent Length, ft. (m)	1.5 Ton		2 Ton		3 Ton	
	Suction	Liquid	Suction	Liquid	Suction	Liquid
50 (15)	5/8"	3/8"	7/8"	3/8"	7/8"	1/2"
75 (23)	7/8"	3/8"	7/8"	3/8"	7/8"	1/2"
100 (30)	7/8"	3/8"	7/8"	1/2"	1-1/8" ²	1/2"
125 (38)	7/8"	1/2"	7/8"	1/2"	1-1/8" ²	1/2"
150 (45)	7/8"	1/2"	7/8"	1/2"	1-1/8" ²	1/2"

1. Suction line and liquid line sizing based on < 3 psi pressure drop in each and horizontal suction line refrigerant velocities > 700 FPM (3.6 m/s).

2. Suction sizes should be reduced one pipe size for vertical riser sections to maintain suction line velocity > 1,000 FPM (5.1 m/s) for proper oil return.

Source: DPN000788 Rev. 13

Table 5.7 Equivalent Lengths for Various Pipe Fittings, ft. (m)

Copper Pipe OD, in.	90 Degree Elbow Copper	90 Degree Elbow Cast	45 Degree Elbow	Tee	Gate Valve	Globe Valve	Angle Valve
1/2	0.8 (0.24)	1.3 (0.39)	0.4 (0.12)	2.5 (0.76)	0.26 (0.07)	7.0 (2.13)	4.0 (1.21)
5/8	0.9 (0.27)	1.4 (0.42)	0.5 (0.15)	2.5 (0.76)	0.28 (0.08)	9.5 (2.89)	5.0 (1.52)
3/4	1.0 (0.3)	1.5 (0.45)	0.6 (0.18)	2.5 (0.76)	0.3 (0.09)	12.0 (3.65)	6.5 (1.98)
7/8	1.45 (0.44)	1.8 (0.54)	0.8 (0.24)	3.6 (1.09)	0.36 (0.1)	17.2 (5.24)	9.5 (2.89)
1-1/8	1.85 (0.56)	2.2 (0.67)	1.0 (0.3)	4.6 (1.4)	0.48 (0.14)	22.5 (6.85)	12.0 (3.65)
1-3/8	2.4 (0.73)	2.9 (0.88)	1.3 (0.39)	6.4 (1.95)	0.65 (0.19)	32.0 (9.75)	16.0 (4.87)
1-5/8	2.9 (0.88)	3.5 (1.06)	1.6 (0.48)	7.2 (2.19)	0.72 (0.21)	36.0 (10.97)	19.5 (5.94)

Refrigerant trap = Four times equivalent length of pipe per this table

5.3 Refrigerant Charge Requirements

Table 5.8 R-407C Refrigerant Unit Charge

60 Hz	50 Hz	Charge R-407C, oz (kg)
DME020E	—	4 (0.11)
DME027E	—	5 (0.14)
DME037E	DME037E	6.5 (0.18)
MCD24AL_HN	—	134 (3.80)
MCD36AL_HN	MCD35AL_HN	213 (6.04)
MCD26W_HN	—	41 (1.16)
MCD38W_HN	MCD37W_HN	54 (1.54)
DMC022WG	—	47 (1.33)
DMC029WG	—	59 (1.67)
DMC040WG	—	61 (1.72)
PFH020A_LN	—	134 (3.80)
PFH027A_LN	—	134 (3.80)
PFH027A_HN	—	213 (6.04)
PFHZ27A_LN	—	213 (6.04)
PFH037A_LN	PFH036A_LN	213 (6.04)
PFH037A_HN	PFH036A_HN	426 (12.08)
PFHZ37A_LN	PFHZ36A_LN	426 (12.08)

Table 5.9 Line Charges of R-407C Refrigerant Using Type-L Copper Tube

Line Size, OD, in.	Liquid Line, lb/100 ft (kg/30 m)	Suction Line, lb/100ft (kg/30 m)
3/8	3.6 (1.6)	—
1/2	6.7 (3.0)	0.2 (0.1)
5/8	10.8 (4.8)	0.3 (0.1)
3/4	16.1 (7.2)	0.4 (0.2)
7/8	22.3 (10.0)	0.5 (0.3)
1-1/8	38.0 (17.0)	0.9 (0.4)
1-3/8	57.9 (25.9)	1.4 (0.7)

Source: DPN003099 Rev. 1

5.3.1 Field Fabricated Refrigeration Piping

Use copper pipe with high temperature brazed joints for all field fabricated refrigeration piping. Use a brazing alloy with a minimum temperature of 1350°F (732°C), such as Sil-Fos. Avoid soft solders such as 50/50 or 95/5.

1. Measure pipe runs and calculate pipe size and equivalent feet of suction and liquid lines per the tables in [Refrigerant Line Sizes and Equivalent Lengths](#) on page 44.
2. Determine the type of trap to use on the suction line next to the evaporator based on the position of the condensing unit per [Piping when Condensing Unit is Above or Below Evaporator](#) on page 43.
3. Determine the number and placement of traps on vertical rises, and install traps on the suction line piping at the base of a rise over 5 ft. (1.5 m) and every 20 ft. (6 m) of vertical rise.
4. The evaporator and condensing units come with an inert gas holding charge. Release pressure before cutting the spun closed end of the piping.

NOTE: You can only evacuate the system properly if you open the hot gas bypass and liquid line solenoid valves (if equipped) inside the condensing unit and you account for all check valves, see [Figure 5.2](#) on the facing page. Connect manifold gauge hoses to the discharge and suction line Schrader ports, remove the solenoid valve holding coils from the hot gas bypass and liquid line solenoid valves (if equipped), and apply a solenoid valve service magnet to the valves to obtain a proper vacuum.

5. Use a flow of dry nitrogen through the piping during brazing to prevent formation of copper oxide scale inside the piping. A pure dry nitrogen flow of 1 to 3 ft.³/min (0.5 to 1.5 l/s) inside the pipe during brazing is sufficient to displace the air. Control the flow using a suitable metering device.

NOTE: Copper oxide forms when copper is heated in the presence of air. POE oil will dissolve these oxides from inside the copper pipes and deposit them throughout the system, clogging filter driers and affecting other system components.

5.3.2 Evacuation and Leak Testing Air Cooled Systems

For proper leak check and evacuation, you must open all system valves and account for all check valves, see [Figure 5.2](#) on the facing page.

Figure 5.2 Valves and Connections

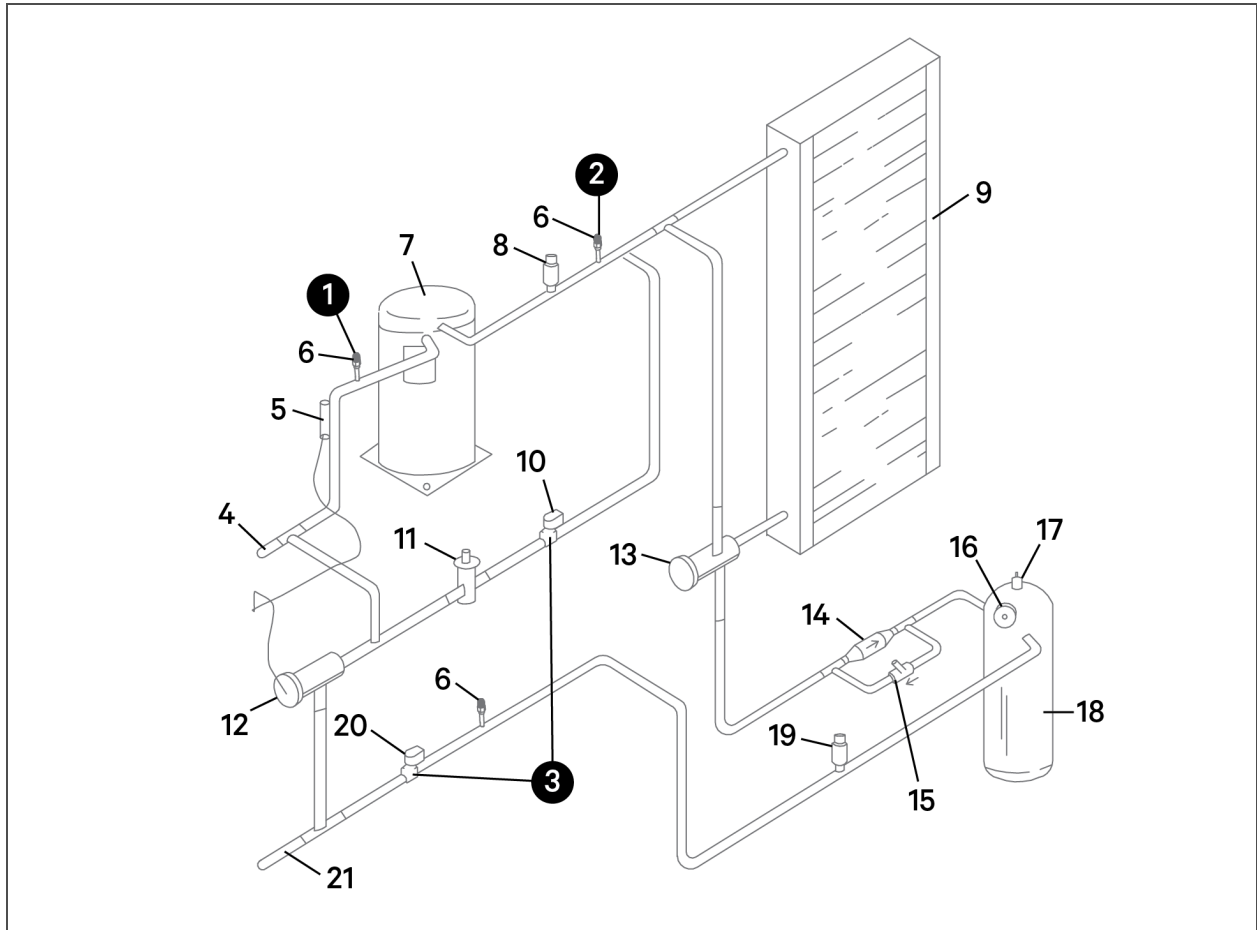

Item	Description
1	Apply a manifold gauge hose on the suction line Schrader port.
2	Apply a manifold gauge hose on the discharge line Schrader port.
3	Unplug the wires and remove the solenoid valve holding coils, then apply solenoid valve service magnets to the valves.
4	Suction line
5	Liquid injection valve bulb
6	Schrader port with valve core NOTE: The system includes a factory installed Schrader valve with core in the liquid line downstream of the receiver. Proper evacuation of the condenser side of the system can be accomplished only using the downstream Schrader valve. See the appropriate piping schematic for your system in Submittal Drawings on page 107.
7	Scroll compressor
8	High pressure switch
9	Condenser coil
10	Hot gas bypass solenoid valve
11	Hot gas bypass control valve
12	Liquid injection
13	3-way head pressure control valve
14	Check valve
15	Pressure-balancing valve
16	Sight glass
17	Pressure relief valve
18	Lee-Temp receiver
19	Receiver-heater pressure-limiting switch
20	Liquid line solenoid valve
21	Liquid line

To evacuate and leak test the system:

1. Open the liquid line solenoid valve and hot gas bypass solenoid valve by removing the holding coils, and apply a solenoid valve service magnet to the valves.
2. Connect manifold gauge hoses on the discharge and suction line Schrader ports, open the service valves, and place a 150 Psig (1034 kPa) charge of dry nitrogen with a tracer of refrigerant, then check the system for leaks with a suitable leak detector.
3. After completion of leak testing, release the test pressure, (observe local code) and pull an initial deep vacuum of 500 microns on the system with a suitable pump.
4. After four hours, check the pressure readings and, if they have not changed, break vacuum with dry nitrogen. Pull a second and third vacuum to 500 microns or less. Re-check the pressure after two hours. When the three checks are complete, proceed to [Charging Air Cooled Systems](#) on the facing page.

5.3.3 Charging Air Cooled Systems

NOTICE

Risk of improper refrigerant charging. Can cause equipment damage.

R-407C is a blended refrigerant and must be introduced and charged from the cylinder only as a liquid.

When adding liquid refrigerant to an operating system, it may be necessary to add the refrigerant through the valve in the compressor suction line. Care must be exercised to avoid damage to the compressor. We recommend connecting a sight glass between the charging hose and the compressor suction service valve. This will permit adjustment of the cylinder hand valve so that liquid can leave the cylinder while allowing vapor to enter the compressor.

To calculate the charge for the system:

1. Check the nameplate on the indoor unit for refrigerant type to use.
2. Refer to [R-407C Refrigerant Unit Charge](#) on page 45, and **Table 5.9** on page 46, and calculate the amount of charge for the system including the evaporator, condensing unit, and interconnecting piping.
3. Accurately weigh-in as much of the system charge as possible before re-installing coils on liquid line solenoid valve and hot gas bypass solenoid valve, and starting the unit.

5.3.4 Field Charge Verification for Air Cooled Systems

An integral sight glass is provided with the receiver to assist in field charge verification. During charge verification, set the control temperature down to keep the system running. If the system is equipped with hot gas bypass, de-energize it by removing power from the hot gas solenoid valve coil. To remove power, disconnect the solenoid leads from the unit contactor in the electric box, see **Figure 5.2** on page 47. When charge verification is complete, replace and secure all wire connections and covers.

During operation at design ambient temperatures, (95 or 105°F; 35 or 41°C) the charge level is above the sight glass in the receiver. If levels are below the sight glass, an undercharge condition is likely. If levels are above the sight glass and higher discharge pressures than normal are observed, an overcharge condition may be likely. However, verify that other high discharge pressure causes such as dirty coil and restricted air flow are not responsible before removing charge.

At temperatures below design ambient temperature, refrigerant backs into the condenser coil and the level in the receiver drops below the sight glass. If you are trying to verify charge level at lower ambient temperatures, block the condenser coil to maintain 240 psig (1655 kPa) discharge pressure to ensure the head pressure control valve is closed. At these conditions, the charge level should be above the sight glass in the receiver.

NOTE: If no level is visible in the sight glass, add charge until the level is in the middle of the sight glass. Check the discharge pressure during this procedure and adjust coil restrictions to maintain 240 psig (1655 kPa). Once the charge is in the middle of the sight glass, add additional system charge per **Table 5.10 on the next page. After charging, unblock the coil and allow the unit to operate normally. After conditions have stabilized, restrict the coil if required to maintain 240 psig (1655 kPa) discharge pressure and verify that the charge level is above the sight glass.**

Table 5.10 Field Verification Charge Addition

Model Numbers		R-407C
60 Hz	50 Hz	oz (kg)
PFH020A-L	—	4 (0.11)
PFH027A-L	—	4 (0.11)
MCD24AL_HN	—	4 (0.11)
PFH027A-H	—	18 (0.51)
PFHZ27A-L	—	18 (0.51)
PFH037A-L	PFH036A-L	18 (0.51)
MCD36AL_HN	—	18 (0.51)
PFH037A-H	PFH036A-H	8 (0.23)
PFHZ37A-L	PFHZ36A-L	8 (0.23)

See **Table 5.8** on page 45, for base charge amount of the condensing unit.

5.3.5 Documenting Refrigerant Charge on Air Cooled Units

When the unit is charged, you must record the total system charge value on the condensing unit's serial tag. The total system charge includes the evaporator, condensing unit, and interconnecting lines.

5.3.6 Evacuation and Leak Testing Water/Glycol Cooled Systems

For proper leak check and evacuation, you must open all system valves and account for all check valves, see **Figure 5.3** on the facing page.

Figure 5.3 Valves and Connections for Remote Water/Glycol Condensing Unit

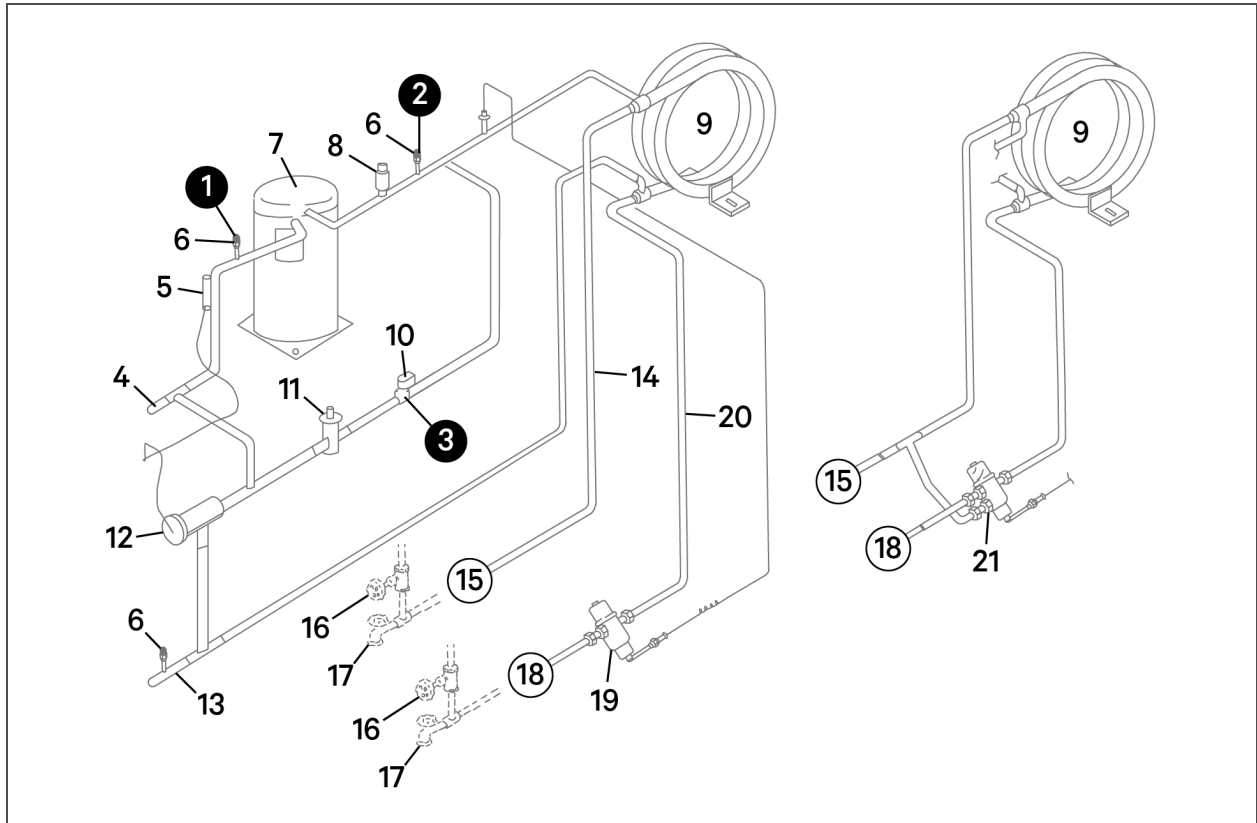

Item	Description
1	Apply a manifold gauge hose on the suction line Schrader port.
2	Apply a manifold gauge hose on the discharge line Schrader port.
3	Unplug the wires and remove the solenoid valve holding coil, then apply a solenoid valve service magnet to the valve.
4	Suction line
5	Liquid injection valve bulb
6	Schrader port with valve core
7	Scroll compressor
8	High pressure switch
9	Tube-in-tube condenser
10	Hot gas bypass solenoid valve
11	Hot gas bypass control valve
12	Liquid injection
13	Liquid line
14	Water/Glycol return line
15	Fluid return from unit
16	Shut-off valves (required, field-supplied)
17	Hose bibs (required, field-supplied)
18	Fluid supply to unit
19	2-way water regulating valve
20	Water/Glycol supply line
21	3-way water regulating valve (optional)

To evacuate and leak test the system:

1. Open the hot gas bypass solenoid valve by removing the holding coil, and apply a solenoid valve service magnet to the valve.
2. Connect a manifold gauge hose on the discharge and suction line Schrader ports, open the service valve, and place a 150 Psig (1034 kPa) charge of dry nitrogen with a tracer of refrigerant, then check the system for leaks with a suitable leak detector.
3. After completion of leak testing, release the test pressure, (observe local code) and pull an initial deep vacuum of 500 microns on the system with a suitable pump.
4. After four hours, check the pressure readings and, if they have not changed, break vacuum with dry nitrogen. Pull a second and third vacuum to 500 microns or less. Re-check the pressure after two hours. When the three checks are complete, proceed to [Charging Water/Glycol Cooled Systems](#) below.

5.3.7 Charging Water/Glycol Cooled Systems

NOTICE

Risk of improper refrigerant charging. Can cause equipment damage.

R-407C is a blended refrigerant and must be introduced and charged from the cylinder only as a liquid.

When adding liquid refrigerant to an operating system, it may be necessary to add the refrigerant through the valve in the compressor suction line. Care must be exercised to avoid damage to the compressor. We recommend connecting a sight glass between the charging hose and the compressor suction service valve. This will permit adjustment of the cylinder hand valve so that liquid can leave the cylinder while allowing vapor to enter the compressor.

To calculate the charge for the system:

1. Check the nameplate on the indoor unit for refrigerant type to use.
2. Refer to [R-407C Refrigerant Unit Charge](#) on page 45, and **Table 5.9** on page 46, and calculate the amount of charge for the system including the evaporator, condensing unit, and interconnecting piping.
3. Accurately weigh-in as much of the system charge as possible before re-installing the coil on the hot gas bypass solenoid valve and starting the unit.

5.3.8 Optimizing Refrigerant Charge on Water/Glycol Units

1. Operate the unit at full heat load, normal room conditions and normal water/glycol fluid temperatures for a minimum of 30 minutes before measuring stable unit superheat and sub-cooling temperatures and adjusting charge levels.
 - Condensing temperatures should be in range of 100 to 130°F (38 to 54°C) depending on fluid type and fluid temperature.
 - Full heat load is required to stabilize the system.
2. Attach pressure and temperature instruments to the liquid line of the condensing unit. Use the factory installed Schrader valve located in the liquid line of the condenser. Measure the initial sub-cooling.

NOTE: To determine sub-cooling measurement, a liquid line pressure reading (at the factory installed Schrader tap) must be measured along with the temperature reading on the liquid line. Convert the liquid line pressure reading into a liquid temperature by utilizing a pressure temperature guide. Subtract the measured temperature from the liquid saturation temperature. The difference is sub-cooling.

3. Adjust refrigerant charge levels as needed to achieve sub-cooling range of 12 to 14°F (6.7 to 7.8°C) while maintaining full load conditions.

5.3.9 Documenting Refrigerant Charge on Water/Glycol-cooled Units

When the unit is charged, you must record the total system charge value on the condensing unit's serial tag. The total system charge includes the evaporator, condensing unit, and interconnecting lines.

This page intentionally left blank

6 ELECTRICAL CONNECTION REQUIREMENTS



WARNING! Arc flash and electric shock hazard. Open all local and remote electric power supply disconnect switches, verify with a voltmeter that power is Off and wear appropriate, OSHA approved personal protective equipment (PPE) per NFPA 70E before working within the electric control enclosure. Failure to comply can cause serious injury or death. Customer must provide earth ground to unit, per NEC, CEC, and local codes, as applicable. Before proceeding with installation, read all instructions, verify that all the parts are included and check the nameplate to be sure the voltage matches available utility power. The Liebert® controller does not isolate power from the unit, even in the Unit Off mode. Some internal components require and receive power even during the Unit Off mode of the controller. The only way to ensure that there is NO voltage inside the unit is to install and open a remote disconnect switch. Refer to unit electrical schematic. Follow all local codes.



WARNING! Risk of improper wire and loose electrical connections. Can cause overheated wire and electrical connection terminals resulting in smoke, fire, equipment and building damage, injury or death. Use correctly sized copper wire only and verify that all electrical connections are tight before turning power On. Check all electrical connections periodically and tighten as necessary.

NOTE: Seal openings around piping and electrical connections to prevent air leakage. Failure to do so could reduce the unit's cooling performance.

NOTICE

Risk of improper electrical supply connection. Can cause equipment damage.

See transformer label for primary tap connections. Installer will need to change transformer primary taps if applied unit voltage is other than pre-wired tap voltage.

All power and control wiring and ground connections must be in accordance with the National Electrical Code and local codes. Refer to the equipment serial tag data for electrical requirements.

A manual electrical disconnect switch should be installed in accordance with local codes and distribution system. Consult local codes for external disconnect requirements.

Each unit is shipped from the factory with internal wiring completed. Refer to the unit's electrical schematic when making connections. Electrical connections to be supplied by the users and made at the installation site are:

- Power supply to the evaporator or chilled water unit.
- Power supply to the condensing unit.
- Power supply to outdoor condensing unit, if applicable.
- Control wiring (shielded) between the evaporator unit and condensing unit, if applicable.
- Control wiring (shielded) between the control panel (wall box) and the evaporator or chilled water unit's control board.

The electrical connections are described in the submittal documents included in the [Submittal Drawings](#) on page 107.

The following table lists the relevant documents by number and title.

Table 6.1 Electrical Field Connection Drawings

Document Number	Title
Evaporator and Chilled Water Units	
DPN000264	Electrical Connections, Evaporator and Chilled Water Units
DPN000271	Electrical Connections, Close Coupled Water/Glycol Cooled Units
DPN004912	Arrangement and Dimensions, IS-UNITY-DP for BMS Communication
DPN004854	Electrical Connections, IS-UNITY-DP for BMS Communication
Split System Indoor Condensing Units	
DPN000207	Electrical Connections, Air Cooled Condensing Units
DPN000209	Electrical Connections, Water/Glycol Cooled Condensing Units

6.1 Input Power Connection Requirements



WARNING! Risk of loose electrical connections. Can cause overheating of wire, smoke and fire resulting in building and equipment damage, injury or death. Use copper wiring only. Verify that all connections are tight.

NOTE: Refer to specifications for full load amp. and wire size amp. ratings.

Voltage supplied must agree with the voltage specified on the unit serial tag. An optional transformer is available for 277-VAC, single phase supply power applications, see DPN000647 in the [Submittal Drawings](#) on page 107. A field supplied disconnect switch is required to isolate the unit for maintenance.

Route the supply power to the disconnect switch, then to the unit. Route the conduit through the hole provided in the cabinet. Connect earth ground to lug provided.

NOTE: When installing a close coupled water/glycol cooled condensing unit, connect the line voltage supply to the condensing unit. The evaporator is powered from the condensing unit with a factory supplied interconnecting cable.

The power terminal connections are labeled L1 and L2. See transformer label for primary tap connections. Installer will need to change transformer primary taps if applied unit voltage is other than pre-wired tap voltage. For 208-VAC applications, input transformer connection must be changed. Refer to the electrical schematic.

6.2 Control Wiring Connection Requirements

6.2.1 Wall Box Controller Control Connections

A four conductor (thermostat type) field supplied, shielded wire must be connected between the evaporator control board and the wall box display. Refer to the appropriate submittal drawings for your system for electrical connections. See **Table 6.1** on the previous page.

6.2.2 Split System Condensing Unit Control Connections

A field supplied, shielded, four wire control connection (24 VAC) is required between the evaporator and the condensing unit.

Control wiring must be installed in accordance with the National Electrical Code (NEC) Class 1 circuit according to wire routing conditions chosen and local codes. Water/Glycol cooled units require a Class 1 circuit. If installing a glycol unit, see [Water/Glycol Cooled Unit Control Connections](#) below, for specific requirements.

Control wiring between the evaporator and the condensing unit must be shielded and sized for a voltage drop of less than 1 volt, see **Table 6.2** below, for recommended minimum gauge by distance. Connect the shield wire to earth (ground) at the Liebert® equipment. Avoid running the low voltage connections near high voltage lines or loads such as light ballasts.

NOTE: Do not connect additional electrical devices to the control circuit. The circuit breaker in the transformer is only sized for factory supplied components. Refer to the appropriate submittal drawings for your system for electrical connections. See **Table 6.1 on the previous page.**

Table 6.2 Recommended Minimum Wire Size

Maximum Distance,* ft (m)	Minimum Wire Gauge, AWG (mm ²)
50 (15)	20 (0.75)
75 (23)	18 (1.0)
100 (30)	18 (1.0)
150 (45)	16 (1.5)
* One-way control wire run between outdoor condensing unit and evaporator.	

6.2.3 Water/Glycol Cooled Unit Control Connections

Glycol cooled units require an additional field supplied, two conductor (thermostat type) wire connection between the evaporator unit and the drycooler. Units with water tower loops can be wired for circulation pump/valve requirement. A Class 1 circuit is required for water/glycol units. Control wiring must be installed in accordance with NEC and local codes. Refer to the appropriate submittal drawings for your system for electrical connections. See **Table 6.1** on the previous page.

6.2.4 Additional Control Connections

If your system includes other optional monitoring and control devices, additional control wiring will be required.

This page intentionally left blank

7 CHECKLIST FOR COMPLETED INSTALLATION

1. Proper clearances for service access have been maintained around the equipment.
2. Equipment is level and mounting fasteners are tight.
3. Piping completed to refrigerant or coolant loop (if required). Refrigerant charge added.
4. Condensate pump installed (if required).
5. Drain line(s) connected and checked for leaks.
6. Water supply line connected to humidifier (if required). Routed to allow air filter removal.
7. All piping connections are checked for leaks. (Correct as required.)
8. Safety drain pan installed under water/glycol cooled condensing units.
9. Drain pan installed under cooling and ceiling mounted condensing unit.
10. Filter box installed on ducted units.
11. Ducting completed, if required.
12. Line voltage to power wiring matches equipment serial tag.
13. Power wiring connections completed between disconnect switch, evaporator, and condensing unit, including earth ground.
14. Power line circuit breakers or fuses have proper ratings for equipment installed.
15. Wall mounted control is mounted and wired to the cooling unit.
16. Shielded control wiring connections used and completed to evaporator and condensing unit (if required), including wiring to wall mounted control panel and optional controls.
17. Control panel DIP switches set based on customer requirements.
18. All wiring connections are tight.
19. Foreign materials have been removed from inside and around all equipment installed (shipping materials, construction materials, tools, etc.)
20. Fans and blowers rotate freely without unusual noise.
21. Inspect all piping connections for leaks during initial operation. Correct as needed.
22. Rubber band is removed from evaporator condensate pan float switch.
23. Monitored water detection system installed for unit, water supply/return lines, and condensate drain line.

This page intentionally left blank

8 INITIAL START-UP CHECKS AND COMMISSIONING PROCEDURE FOR WARRANTY INSPECTION



WARNING! Arc flash and electric shock hazard. Open all local and remote electric power supply disconnect switches, verify with a voltmeter that power is Off and wear appropriate, OSHA approved personal protective equipment (PPE) per NFPA 70E before working within the electric control enclosure. Failure to comply can cause serious injury or death. Customer must provide earth ground to unit, per NEC, CEC, and local codes, as applicable. Before proceeding with installation, read all instructions, verify that all the parts are included and check the nameplate to be sure the voltage matches available utility power. The Liebert® controller does not isolate power from the unit, even in the Unit Off mode. Some internal components require and receive power even during the Unit Off mode of the controller. The only way to ensure that there is NO voltage inside the unit is to install and open a remote disconnect switch. Refer to unit electrical schematic. Follow all local codes.



WARNING! Risk of improper wiring, piping, moving, lifting and handling. Can cause equipment damage, serious injury or death. Installation and service of this equipment should be done only by qualified personnel, wearing appropriate, OSHA approved PPE, who have been specially trained in the installation of air conditioning equipment.

- Confirm that all items on [Checklist for Completed Installation](#) on page 59, have been done.
- Locate “Liebert® DataMate Warranty Inspection Check Sheet” in the unit’s electric panel. (PSWI-8542-403RE).
- Complete “Liebert® DataMate Warranty Inspection Check Sheet” during start-up. (PSWI-8542-403RE).
- Forward the completed “Liebert® DataMate Warranty Inspection Check Sheet” to your local sales office. **This information must be completed and forwarded to validate warranty.**
- Contact your local sales representative or technical support if you have any questions or problems during unit start-up and commissioning. Visit <https://www.vertiv.com/en-us/support/> or call 1-800-543-2778 for contacts.

This page intentionally left blank

9 MICROPROCESSOR CONTROL

The Microprocessor Control for the Liebert® DataMate features a menu driven LCD. The menus, control features, and circuit board are described in this section. Detailed information concerning controls ([System Control and Performance](#) on page 80) and alarms ([Alarm Notification, Acknowledgment, and Descriptions](#) on page 81) are provided.

9.1 Controller Operation

Setpoints, DIP switch settings and other selections were made during factory testing of your unit and are based upon typical operating experience. Other default selections were made according to options included with your unit.

NOTE: Only make adjustments to the factory default settings if they do not meet your specifications.

When adjusting setpoints and configuration, allowable ranges are displayed by pressing the help key. If enabled, a password is required to change setpoints, time delays, and other settings.

The default display normally shows the present room temperature, humidity, active status functions (cooling, heating, dehumidifying, humidifying), fan speed, and active alarms.

The controller includes an LCD display and eight buttons to navigate the display.

Figure 9.1 Control Keys on the Wall Mounted Display

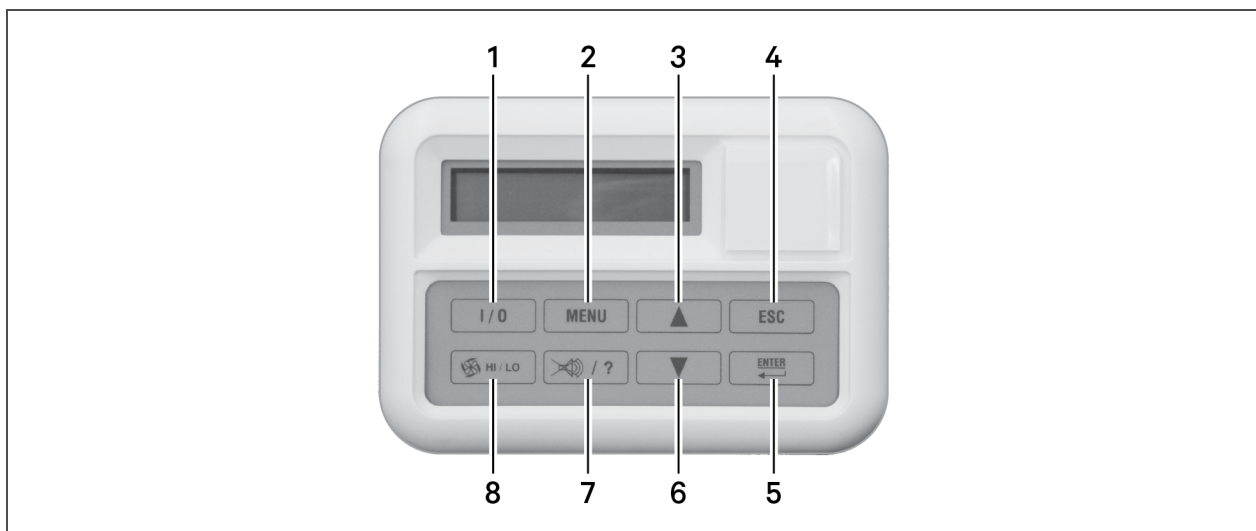

Item	Description
1	I/O (On/Off)
2	Menu, displays program menu.
3	Up arrow, increases parameter value in a settings mode.
4	Escape, backs up to a preview menu.
5	Enter, saves settings/changes.
6	Down arrow, decreases parameter value in a settings mode.
7	Alarm Silence/Help, silences active alarm(s). Displays help text when there is no alarm.
8	HI/LO, selects fans speed.

9.1.1 Powering On/Off with Wall Mounted Display

To power on the system:

Press I/O after power is applied.

To power off the system:

Press I/O before power is disconnected.

9.1.2 Silencing an Audible Alarm

Active alarms are displayed on the LCD screen and sound an audible beeper.

To silence an audible alarm:

Press the Alarm Silence/Help button.

The alarm notification remains visible on the LCD screen.

9.2 Main Menu <MENU>

The menu options are shown in **Figure 9.2** on page 66. The options differ only slightly depending on the size of the unit. The differences are noted in the option descriptions.

To select a menu option:

1. Press the MENU key.
2. Use the Up/Down arrows to highlight a selection, then press *Enter*.

Main Menu Options

SETPOINTS

See [Editing Setpoints](#) on page 67.

STATUS

See [Viewing Unit Status](#) on page 67.

ACTIVE ALARMS

See [Viewing Active Alarms](#) on page 68.

TIME

See [Setting Controller Time](#) on page 68.

DATE

See [Setting Controller Date](#) on page 68.

SETBACK

See [Programming Setback](#) on page 68.

SETUP OPERATION

See [Editing Setup Operation](#) on page 69

SETPOINT PASSWORD

See [Changing Setpoint and Setup Passwords](#) on page 71

SETUP PASSWORD

See [Changing Setpoint and Setup Passwords](#) on page 71.

CALIBRATE SENSORS

See [Calibrating Sensors and Setting Sensor Response Delay](#) on page 71.

ALARM ENABLE

See [Enabling/Disabling Alarms](#) on page 72.

ALARM TIME DELAY

See [Setting Alarm Delays](#) on page 72.

COMMON ALARM ENABLE

See [Activating the Common Alarm Relay](#) on page 73.

CUSTOM ALARMS

See [Configuring Custom Alarms](#) on page 74.

CUSTOM TEXT

See [Customizing Alarm Message Text](#) on page 74.

DIAGNOSTICS

See [Running Diagnostics](#) on page 76.

Figure 9.2 Control Menu Example

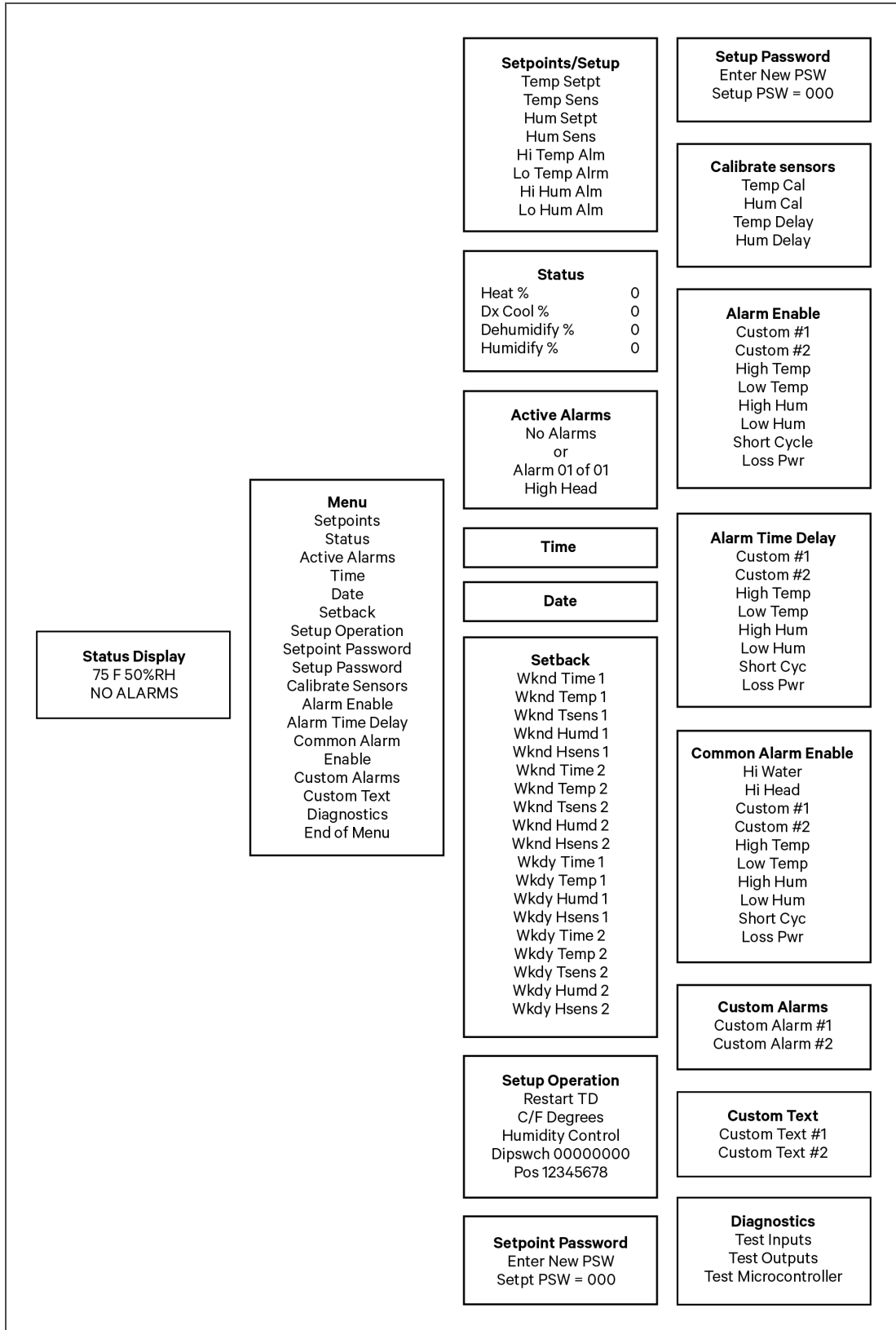

9.2.1 Editing Setpoints

Setpoints are kept in non-volatile memory. The setpoint options are:

- TEMPERATURE SETPOINT
- TEMPERATURE SENSITIVITY
- HUMIDITY SETPOINT
- HUMIDITY SENSITIVITY
- HIGH TEMPERATURE ALARM
- LOW TEMPERATURE ALARM
- HIGH HUMIDITY ALARM
- LOW HUMIDITY ALARM

Table 9.1 below, lists the default setting and allowed range for each setpoint.

Table 9.1 Default Setpoints and Allowable Ranges

Setpoint	Default	Range
Temperature Setpoint	72°F	40-90°F (5-32°C)
Temperature Sensitivity	2.0°F	1-9.9°F (0.6-5.6°C)
Humidity Setpoint	50%	20-80% RH
Humidity Sensitivity	5%	1-30% RH
High Temperature Alarm	80°F	35-95°F (2-35°C)
Low Temperature Alarm	65°F	35-95°F (2-35°C)
High Humidity Alarm	60%	15-85% RH
Low Humidity Alarm	40%	15-85% RH

To adjust a setpoint:

1. Press the MENU key.
2. Use the Up/Down arrows to highlight SETPOINTS, then press *Enter*.
3. Use the Up/Down arrows to highlight a setpoint option, then press *Enter*.
4. Use the Up/Down arrows to change the value, then press *Enter* to store the value.

9.2.2 Viewing Unit Status

The Status options displays percentage heating, cooling, dehumidifying and humidifying status of the unit

To view the unit status:

1. Press the MENU key.
2. Use the Up/Down arrows to highlight STATUS, then press *Enter*.

9.2.3 Viewing Active Alarms

Alarms display on the LCD as No Alarm Present or Alarm XX of YY, where XX is the number of the alarm and YY is the total number of active alarms.

To view active alarms:

1. Press the MENU key.
2. Use the Up/Down arrows to highlight ACTIVE ALARMS, then press *Enter*.
3. If there is more than one active alarm, use the Up/Down Arrows to scroll through the alarms list.

9.2.4 Setting Controller Time

The controller time clock must be set to allow for the setback control. The clock uses the 24-hour system (that is, 12 midnight is entered as 24:00).

To set the time:

1. Press the MENU key.
2. Use the Up/Down arrows to highlight TIME, then press *Enter*.
3. Use the Up/Down arrows to change the each character, pressing *Enter* to store it and move to the next character.

NOTE: Date and Time features have a battery backup.

9.2.5 Setting Controller Date

The controller date must be set to allow for the setback control.

To set the date:

1. Press the MENU key.
2. Use the Up/Down arrows to highlight DATE, then press *Enter*.
3. Use the Up/Down arrows to change each character, pressing *Enter* to store it and move to the next character.

NOTE: Date and Time features have a battery backup.

9.2.6 Programming Setback

The microprocessor can be programmed for night and weekend setback. Two events can be programmed for a five day work week and two events can be programmed for a two day weekend. Use **Table 9.2** on the facing page, to devise a setback plan.

To program a setback plan:

1. Press the MENU key.
2. Use the Up/Down arrows to highlight SETBACK, then press *Enter*.
3. Use the Up/Down arrows to change the values, then press *Enter* to store the value.

Table 9.2 Night and Weekend Setback Plan

Event	Weekend	Weekday
Time 1		
Temperature 1		
Sensitivity 1		
Humidity 1		
Humidity Sensitivity 1		
Time 2		
Temperature 2		
Sensitivity 2		
Humidity 2		
Humidity Sensitivity 2		

9.2.7 Editing Setup Operation

System set-up parameters are kept in non-volatile memory.

To edit the setup:

1. Press the MENU key.
2. Use the Up/Down arrows to highlight SETUP OPERATION, then press *Enter*.
3. Use the Up/Down arrows to highlight a setup option, then press *Enter*.
4. Use the Up/Down arrows to change the value, then press *Enter* to store the value.

Table 9.3 below, lists the default setting and allowed range for each function.

Table 9.3 Setup Functions, Default Values and Allowable Ranges

Function	Default	Range
Restart Time Delay	0.1 min	0 to 9.9 min (0 = manual restart)
C/F Degrees	°F	°C or °F
Humidity Control	Rel	Relative or Absolute

Setup options

RESTART TIME DELAY

Selects a delay before restarting the unit after main power is restored to the unit.

- Delay can be set from 0.1 minutes (6 seconds) to 9.9 minutes.
- If several units are operating, set different delays for a sequential start up.
- Setting the value to zero (0) prevents unit restart when power is restored. In this case, the unit must be restarted manually by pressing the On/Off button on the keypad.

C/F DEGREES

Selects Fahrenheit (F) or Celsius (C) for display readings/setpoints.

HUMIDITY CONTROL METHOD

Selects relative (direct) or absolute (predictive) for humidity control. The LCD displays the percentage relative humidity for both methods of control and if absolute is selected, the adjusted humidity reading is also displayed.

- If relative is selected, the RH control is taken directly from the RH sensor.
- If absolute is selected, the RH control automatically adjusts when return air temperature deviates from the desired temperature setpoint (i.e., predictive humidity control). Predictive humidity control automatically adjusts the humidity level ~2% RH for each degree difference between the return air temperature and the temperature setpoint.

For more details about selecting the humidity control method, see [Humidity Control and Overcooling](#) below.

Humidity Control and Overcooling

When using the relative (direct) humidity control method, unnecessary dehumidification can result when overcooling occurs during a dehumidification cycle. This happens when a higher than normal RH reading is caused by overcooling the room (about 2% RH for each degree of overcooling). This temperature drop extends the dehumidification cycle. Later, when dehumidification ends and the temperature rises to the setpoint, the RH reading falls to a reading lower than actually desired. If the temperature drop is significant enough, the percentage RH could be low enough to activate the humidifier.

Using the absolute (predictive) humidity method may avoid over dehumidification. When overcooling causes an increase in the RH reading, the humidity control program estimates what the RH will be when the dehumidification cycle ends and temperature returns to the setpoint and allows the dehumidification cycle to end at the proper time. Predictive humidity control can greatly reduce energy consumption by minimizing compressor/reheat operation and eliminating unnecessary operation.

9.2.8 Changing Setpoint and Setup Passwords

When you attempt to make changes, the display prompts you for a three digit password. The passwords provide system security, so that only authorized personnel may make changes. If unauthorized changes occur, the passwords may be compromised and new ones should be set.

The system includes two passwords with the following factory default settings:

- Default setup password = 3 - 2 - 1
- Default setpoint password = 1 - 2 - 3

To change a password:

First enter the default password, then enter the new password.

NOTE: The password function can be disabled by setting DIP switch 8 in the wall box to OFF and then cycling power to the unit.

9.2.9 Calibrating Sensors and Setting Sensor Response Delay

If you suspect that the temperature and/or humidity readings are not accurate, you can calibrate the sensors to match the display using your portable, calibrated test instrument and the CALIBRATE SENSORS menu. The temperature sensor can be calibrated $\pm 5^{\circ}\text{F}$. The humidity sensor can be calibrated $\pm 10\%$ RH.

If the sensors are subject to frequent wide temperature and humidity swings, it may be necessary to shorten the cycling by increasing the sensor time delay. If the sensors are located too close to the air discharge, they will likely experience rapid swings in measurement. Another method in reducing compressor cycling is to increase the temperature and/or humidity sensitivity.

The calibration and delay options are:

- SET TEMP CAL—calibrates the temperature sensor $\pm 5^{\circ}\text{F}$ ($\pm 2.8^{\circ}\text{C}$).
- SET HUM CAL—calibrates the humidity sensor $\pm 10\%$.
- SET TEMP DELAY—sets the time delay for sensor response 10 to 90 seconds (default setting = 50 seconds).
- SET HUMID DELAY—sets the time delay for sensor response 10 to 90 seconds (default setting = 50 seconds).

To calibrate a sensor:

1. Make sure the unit is operating and has maintained stable operating conditions for at least 15 minutes.
2. Place the test instrument as close as possible to the sensors to obtain an accurate reading for comparison.
3. At the controller, press the MENU key.
4. Use the Up/Down arrows to highlight CALIBRATE SENSORS, then press *Enter*.
5. Use the Up/Down arrows to highlight a calibration option, then press *Enter*.
6. Use the Up/Down arrows to adjust the unit's sensor reading to match the reading from the test device, then press *Enter* to store the value.

IMPORTANT! When calibrating the humidity sensor, the calibration value is always displayed in % RH, even when absolute humidity control is selected for the unit. If absolute humidity control is selected, the Normal Status Display displays the adjusted reading, which may not agree with the relative humidity reading that displays in calibration.

To set sensor response time delay:

1. Press the MENU key.
2. Use the Up/Down arrows to highlight CALIBRATE SENSORS, then press *Enter*.
3. Use the Up/Down arrows to highlight a set delay option, then press *Enter*.
4. Use the Up/Down arrows to adjust the delay, then press *Enter* to store the value.

9.2.10 Enabling/Disabling Alarms

Many individual alarms may be enabled or disabled. When enabled, an alarm annunciates audibly, visibly, and communicates to a connected site monitoring system. When disabled, the alarm is completely ignored.

The alarms available for adjustment are:

- Custom Alarm #1
- Custom Alarm #2
- High Temperature
- Low Temperature
- High Humidity
- Low Humidity
- Short Cycle
- Loss of Power

To set enable or disable an alarm:

1. Press the MENU key.
2. Use the Up/Down arrows to highlight ALARM ENABLE, then press *Enter*.
3. Use the Up/Down arrows to highlight an alarm option, then press *Enter*.
4. Use the Up/Down arrows to enable/disable, then press *Enter* to store the value.

NOTE: When the alarm is disabled it will not report to the wall box or the common alarm relay.

NOTE: Even when the high water alarm is disabled, the unit automatically shuts off when a high water incident occurs.

NOTE: The standard, factory installed high water alarm and high head pressure alarms cannot be disabled.

9.2.11 Setting Alarm Delays

For each alarm, you can set an amount of time to delay the notification after an alarm condition occurs. If the alarm condition resolves before the delay elapses, there is no alarm notification and the time delay resets automatically. The delay may be set for 0 to 255 seconds, in one second intervals. **Table 9.4** on the facing page, lists each alarm and the default delay setting.

NOTE: Software alarms such as loss of power and short cycle, should be left at the factory default of 0.

Table 9.4 Default Alarm Delay Times

Alarm	Default Time Delay, seconds
Hum Prob	2
High Head Pressure	2
Custom Alarm #1	0
Custom Alarm #2	6
High Temperature	30
Low Temperature	30
High Humidity	30
Low Humidity	30
Short Cycle	0
Loss of Power	0

To set alarm delay times:

1. Press the MENU key.
2. Use the Up/Down arrows to highlight ALARM TIME DELAY, then press *Enter*.
3. Use the Up/Down arrows to highlight an alarm option, then press *Enter*.
4. Use the Up/Down arrows to select the delay, then press *Enter* to store the value.
5. Repeat steps 3 and 4 for each alarm delay to set.

NOTE: The delay for the standard, factory installed high head pressure alarm is not adjustable.

9.2.12 Activating the Common Alarm Relay

Each alarm can be set to activate the common alarm relay. The common alarm relay is K5. See [Enabling/Disabling Alarms](#) on the previous page, for the list of available alarms.

When set to YES (enabled), the relay energizes immediately when the alarm annunciates and de-energizes when the alarm is acknowledged. When set to NO (disabled), an alarm has no effect on the common alarm relay.

To set an alarm to trigger the common alarm relay:

1. Press the MENU key.
2. Use the Up/Down arrows to highlight COMMON ALARM ENABLE, then press *Enter*.
3. Use the Up/Down arrows to highlight an alarm option, then press *Enter*.
4. Use the Up/Down arrows to select YES/NO, then press *Enter* to store the value.
5. Repeat steps 3 and 4 for each alarm needed to activate the common alarm.

9.2.13 Configuring Custom Alarms

You can select custom alarm messages from a list of standard messages or you can create up to two custom text messages for selection. The following are the messages available for custom alarms:

- Filter Clog
- Humidifier Problem
- Water Flow Loss
- Loss of Air Flow
- Custom Text #1 (See [Customizing Alarm Message Text](#) below to create a custom message.)
- Custom Text #2 (See [Customizing Alarm Message Text](#) below to create a custom message.)

To select the message for a custom alarm:

1. Press the MENU key.
2. Use the Up/Down arrows to highlight CUSTOM ALARMS, then press *Enter*.
3. Use the Up/Down arrows to highlight the alarm, then press *Enter*.
4. Use the Up/Down arrows to select the message, then press *Enter* to store the value.

9.2.14 Customizing Alarm Message Text

IMPORTANT! If using custom text messages, notify maintenance personnel of the alarm function and required action.

You can create custom messages for your custom alarms up to 20 characters in length including blank spaces or any of the following alphanumeric characters and symbols:

A, B, C, D, E, F, G, H, I, J, K, L, M, N, O, P, Q, R, S, T, U, V, W, X, Y, Z

#, %, *, -

0, 1, 2, 3, 4, 5, 6, 7, 8, 9

To create custom text message:

1. Press the MENU key.
2. Use the Up/Down arrows to highlight CUSTOM TEXT, then press *Enter*.
3. Use the Up/Down arrows to highlight the custom text option, then press *Enter*.
4. Use the Up/Down arrows to select the character, press *Enter* to store the value until the entire message is stored.
5. To use the custom message, select it from the CUSTOM ALARMS menu. See [Configuring Custom Alarms](#) above.

9.2.15 LCD Display Contrast

You can adjust the level of contrast to help with the viewing angle of the LCD display using a potentiometer screw inside the wall box next to the display.

9.2.16 Non-volatile Memory

All critical information is stored in nonvolatile memory. Setpoints and setup parameters are kept inside the microcontroller in EEPROM.

9.2.17 Equipment Options DIP Switches

Equipment options are selected and enabled using a set of DIP switches mounted on the control board inside the ceiling mounted evaporator. The switches are factory set and should not be changed.

The switch settings on the control board are recognized by the microprocessor control and may be reviewed in the LCD display. **Table 9.5** below, show the setting options. See [Editing Setup Operation](#) on page 69, to review the settings on the display.

Figure 9.3 on page 78 shows the DIP switches on control board in the evaporator unit. **Figure 9.4** on page 79 shows the DIP switches on control board in the wall mounted controller.

NOTE: To update the DIP switch settings, power must be cycled Off, then On from the unit disconnect switch.

Table 9.5 Equipment Option DIP Switch Settings (on Unit Control Board)

Switch	OFF Position	ON Position
1	Compressor	Chill Water
2	Not Used. Must remain in OFF position.	
3	Not Used. Must remain in OFF position.	
4	Not Used. Must remain in OFF position.	
5	Enable Reheat	Disable Reheat
6	Enable Humidifier	Disable Humidifier
7	Enable Dehumidifier	Disable Dehumidifier
8	Not Used. Must remain in OFF position.	

Table 9.6 DIP Switch Settings on Wall Box Board

Switch	OFF Position	ON Position
1	Beeper Disable	Beeper Enable
2	Not Used. Must remain in OFF position.	
3	Not Used. Must remain in OFF position.	
4	Not Used. Must remain in OFF position.	
5	Not Used. Must remain in OFF position.	
6	Not Used. Must remain in OFF position.	
7	Disable Setback	Enable Setback
8	Enable Password	Disable Password

9.3 Running Diagnostics

Using the diagnostics tools, you can view system inputs and outputs and test the microcontroller without interrupting normal operation of the unit. Testing system outputs temporarily suspends normal system control and operation.

9.3.1 Showing Test Inputs

You can view the input state of the devices listed in **Table 9.7** below, with the unit on and the fan running.

To show the test inputs:

1. Press the MENU key.
2. Use the Up/Down arrows to highlight DIAGNOSTICS, then press *Enter*.
3. Use the Up/Down arrows to highlight TEST INPUTS, then press *Enter*.
4. Use the Up/Down arrows to scroll through the inputs list.

Table 9.7 Test Inputs

Input Circuit	Normal Status
High Water Alarm	Off unless High Water Alarm is active.
High Head Pressure Alarm	Off unless High Head Pressure Alarm is active.
Custom alarm #1	Off unless this special customer selectable alarm is active.
Custom alarm #2	Off unless this special customer selectable alarm is active.
Power	On unless unit is turned off through the wall box or any of the following optional devices: high temperature sensor, smoke detector, High Water Alarm or Remote Shutdown.

9.3.2 Testing Outputs

NOTICE

Risk of overheating the compressor during the Test Output mode. Testing the compressor output for more than a few seconds can cause compressor damage.

Extended unit operation in the Test Outputs mode may damage the unit. Do not operate the unit in the Test Outputs mode any longer than is necessary for troubleshooting.

NOTICE

Risk of extended unit operation in the test outputs mode for troubleshooting. Can cause damage to the unit.

Do not operate unit in the test outputs mode any longer than is necessary for troubleshooting.

The outputs available are:

- Normal fan: normal speed fan contactor
- Low Speed Fan: low speed fan contactor (on direct drive blower units only)
- Humidifier: steam humidifier contact (if present)
- Cool: compressor contactor or chilled water valve
- HGBP: hot gas bypass valve (if present)
- Reheat: reheat contactor (if present)
- Common Alarm: common alarm relay

When testing outputs, the unit is effectively turned off. When stepping from one load to the next, the previous load is automatically turned off if it was on.

NOTE: Compressor is limited to 15 seconds On to prevent damage.

NOTE: When testing outputs, the fan is turned On with all loads. After six minutes without user input, the controller automatically exits test output mode and returns to normal operation.

To test the outputs:

1. Press the MENU key.
2. Use the Up/Down arrows to highlight DIAGNOSTICS, then press *Enter*.
3. Use the Up/Down arrows to highlight TEST OUTPUTS, then press *Enter*.
4. Use the Up/Down arrows to highlight the output to test, then press *Enter* to toggle the load on/off. The output remains for five minutes unless toggled Off, when you step to the next load, or when you exit the test outputs function.

9.3.3 Testing the Microcontroller

When selected, the microcontroller performs a self-test that lasts approximately 10 seconds. When the test is complete, the display shows the ROM checksum, ROM part number, and the firmware revision number.

To test the microcontroller:

1. Press the MENU key.
2. Use the Up/Down arrows to highlight DIAGNOSTICS, then press *Enter*.
3. Use the Up/Down arrows to highlight TEST MICROCONTROLLER, then press *Enter*.

Figure 9.3 on the next page, shows the control board in the evaporator unit. **Figure 9.4** on page 79, shows the connections on control board in the wall mounted controller.

Figure 9.3 Control Board Inside the Evaporator

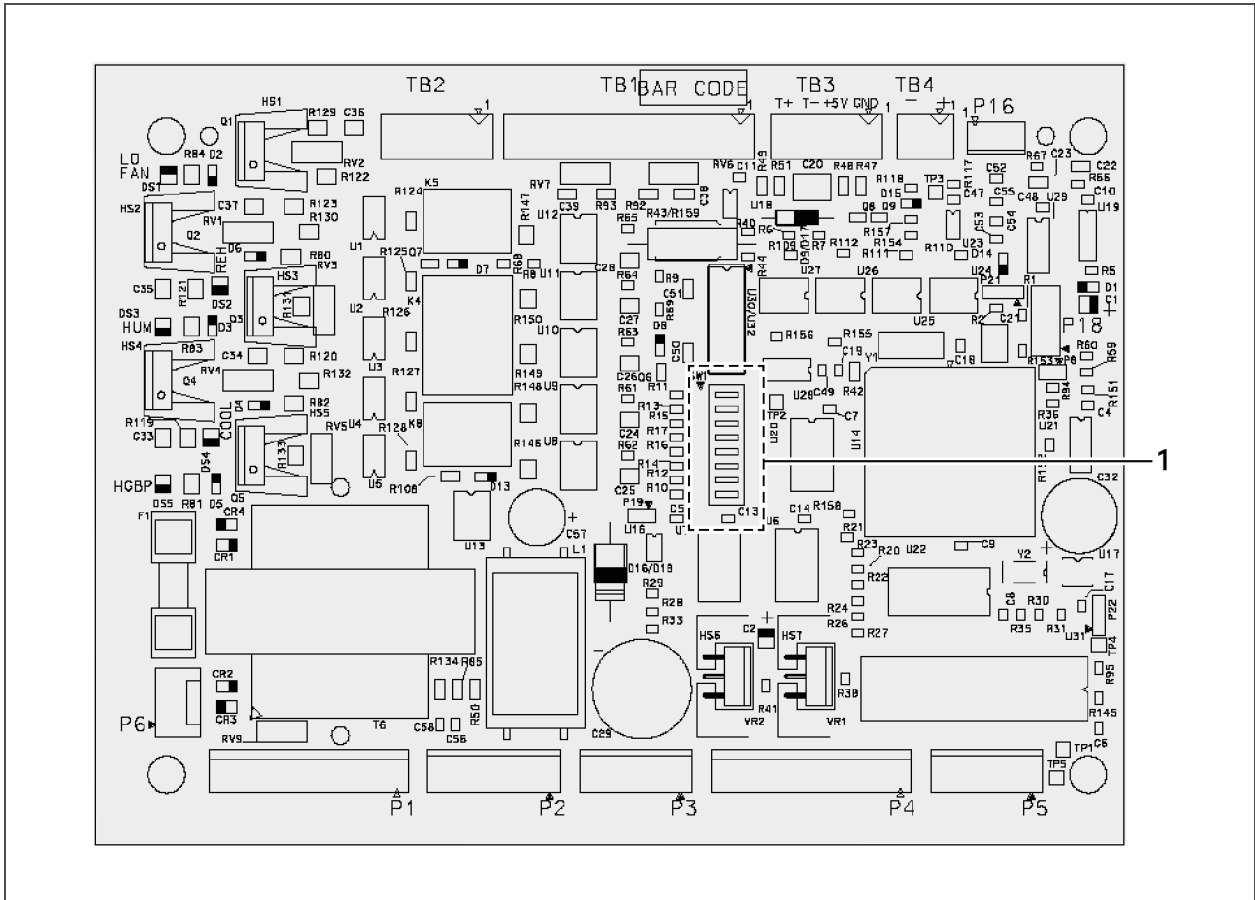

Item	Description
1	DIP switches 1 – 8

Table 9.8 Connections/Functions of Control Board Inside Evaporator

Connection	Function	Connection	Function
TB2-4	Hot Gas Bypass	TB1-2	Customer Alarm Connection #1
TB2-3	High Head Alarm Connection	TB1-1	Customer Alarm Connection (Common)
TB2-2	Heat Rejection (24 VAC+)	TB3-4	Connection to Terminal #4 Wall Box
TB2-1	Heat Rejection (24 VAC GND)	TB3-3	Connection to Terminal #3 Wall Box
TB1-9	Condensate Pump Aux Alarm	TB3-2	Connection to Terminal #2 Wall Box
TB1-8	Condensate Pump Aux Alarm	TB3-1	Connection to Terminal #1 Wall Box
TB1-7	Common Alarm Connection	TB4-2	Site Monitoring Connection (-)
TB1-6	Common Alarm Connection	TB4-1	Site Monitoring Connection (+)
TB1-5	Remote Shutdown	P16	Remote Sensor Connection
TB1-4	Remote Shutdown		
TB1-3	Customer Alarm Connection #2		

Figure 9.4 Control Board Inside the Wall Mounted Controller

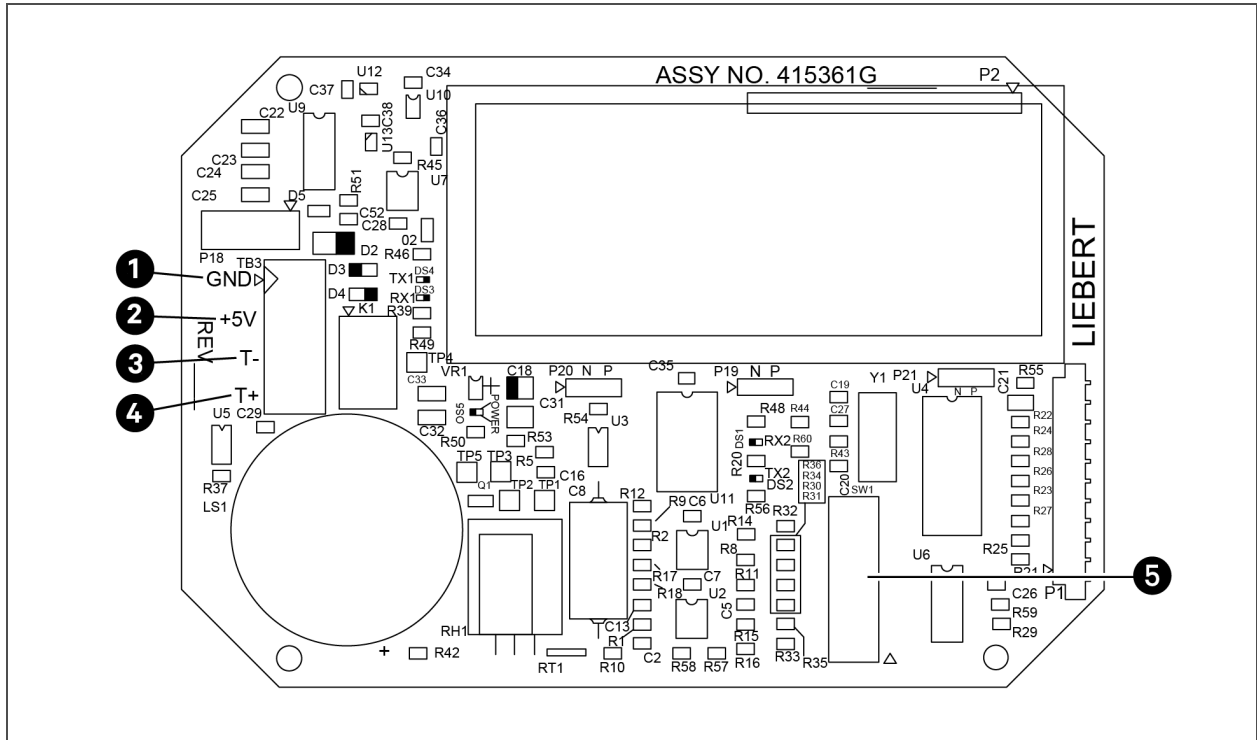

Item	Description
1	TB3-1
2	TB3-2
3	TB3-3
4	TB3-4
5	DIP switches 1 to 8

9.4 System Control and Performance

This section describes how the DataMate responds to operator input and room conditions.

9.4.1 Temperature Control

The following describes the methods of temperature control and determining cooling requirement for the various DataMate cooling types.

9.4.2 Cooling/Heating Required

Temperature control by the microprocessor is based on a calculated percentage requirement for cooling/heating.

Cooling Operation for Compressorized (DX) and Chilled Water Systems

Cooling is activated when the temperature control calculates a cooling requirement of 100% and deactivated when the cooling requirement drops below 50%. Hot gas bypass is activated when a call for cooling occurs unless there is also a call for dehumidification.

Table 9.9 Hot Gas Bypass Response to Cooling and Dehumidification Modes

Mode	Hot Gas Bypass
Cooling Only	ON
Dehumidification Only	OFF
Cooling with Dehumidification	OFF

9.4.3 Electric Reheat

Heating is activated when the temperature control calculates a heating requirement of 100% and deactivated when the heating requirement drops below 50%.

9.4.4 Humidity Control

The following describes the methods of humidity control and determining humidification/dehumidification requirement for the various DataMate cooling types.

Humidification Operation

The humidifier activates when the humidity control calculates a 100% humidification requirement, and it is deactivated when the humidification requirement falls below 50%.

Dehumidification/Humidification Percent Required

The humidity control for the DataMate is based on a calculated percent requirement for dehumidification or humidification. The percent requirement is calculated from the difference between the sensor reading and the humidity setpoint, divided by the sensitivity. The control method is selectable between relative and absolute. Relative humidity control is the default.

Dehumidification Operation for Compressorized (DX) Systems

Dehumidification in the standard configuration operates the compressor without the hot gas bypass active. The fan operates at low speed unless the cooling requirement reaches 100%. At 100% cooling requirement, the low speed fan is disabled (unless manually overridden) until the cooling requirement decreases to 0%. Dehumidification is also disabled if the heating requirement exceeds 125% and is re-enabled when the heating requirement reaches 50%.

9.4.5 Load Control

The control system monitors the compressor and prevents it from turning on within a three-minute period of being off. If this on-off-on cycle occurs too often (for example: 10 times in a one-hour period), a Short Cycle Alarm occurs.

9.4.6 Monitoring

Liebert IS-UNITY-DP - Field Installed Kit

The IS-UNITY-DP card provides full building management system (BMS) access via BACnet/Modbus IP and BACnet/Modbus 485. Card provides access and supports SNMP v1/v2c/v3 and Liebert® Nform™. The wall mount kit for field installation includes the IS-UNITY-DP card, power/communication interface card, painted enclosure, 120-V wall outlet transformer with 6-ft. (2-m) low voltage power wire, and full instructions. Field supplied wiring for communication to the Liebert DataMate and to other systems is required to access features.

9.5 Alarm Notification, Acknowledgment, and Descriptions

The microprocessor control system audibly and visually signals all enabled alarms including custom alarms. See [Configuring Custom Alarms](#) on page 74, for settings and customization options.

When a new alarm occurs, it is displayed on the screen and the audible alarm is activated. (If communicating with a Liebert® monitoring product, the alarm is also transmitted.) The message PRESS ALARM SILENCE prompts you to silence the alarm. After the alarm is silenced, the display return to the Normal Status display. Alarms can also be silenced through communication with a Liebert® monitoring product unit. See [Viewing Active Alarms](#) on page 68.

Many alarms reset automatically when the alarm condition is no longer represented and after it has been acknowledged by being silenced. The exceptions are:

- Software Alarms—Loss of Power alarms reset automatically 30 seconds after being silenced or acknowledged. Short Cycle alarms reset automatically 90 minutes after being silenced or acknowledged.
- Alarms that monitor overload or high pressure switches may require a manual reset depending upon the model.

The following sections describe and provide troubleshooting suggestions for each type of alarm. See [Troubleshooting](#) on page 101 for additional details. If you need further assistance, contact your Vertiv representative.

NOTE: Alarms are specific at the time the unit is ordered. Additional devices and wiring at the factory may be required for some alarms.

9.5.1 Custom Alarms

Custom alarm(s) messages are programmed at the LCD display. The message displayed may be included in a list of provided alarms or it may be customized text (for up to two alarms). See [Configuring Custom Alarms](#) on page 74.

IMPORTANT! If using custom text messages, notify maintenance personnel of the alarm function and required action.

9.5.2 High Head Pressure Alarm

Compressor head pressure is monitored with a pressure sensor switch. (One SPDT pressure switch is used per refrigeration circuit). If head pressure exceeds 400 psig (2,760 kPag), the switch turns off the compressor contactor and sends an input signal to the control.

Acknowledge the condition by pressing the alarm silence button on the wall box, which will clear if the high head pressure is alleviated. If the compressor is off for one hour, the control goes into a special cold start mode. In the cold start mode on a call for cooling or dehumidification, the liquid line solenoid valve (LLSV) is energized. If the high pressure switch does NOT trip within 10 seconds, the control returns to normal operation of monitoring the high head pressure switch for three occurrences in a 12-hour period. It is a rolling timer and after the third high head alarm occurs and is acknowledged by the user, it will lock off the compressor.

If while in the cold start mode, the high head pressure switch DOES trip within 10 seconds of the activation of the LLSV, the control does not annunciate the alarm. The control will turn off the LLSV and delay 10 seconds. The control will permit this occurrence two more times or a total of three times. If on the fourth try, the high head pressure switch trips within 10 seconds, the control will annunciate the alarm, turn off the LLSV, wait for the user to acknowledge the alarm and hold the compressor off for three minutes, the length of the normal short cycle control. The control will permit this occurrence three times. On the third occurrence, the control will lock the compressor off until the control power is reset. After the head pressure problem is fixed, reset the control by disconnecting power to the evaporator unit.

To address a high head-pressure alarm:

- On air cooled systems—check for power shut off to the condensing unit, condensing unit fan not working, defective head pressure control valves, dirty condenser coils or crimped lines. Also, make sure that side switch on the compressor contactors close to energize the condensing unit control circuit.
- On water/glycol cooled systems—Check water regulating valves. Verify water/glycol flow (pumps are operating and service valves are open). Is water tower or drycooler operating? Is the coolant temperature entering the condensing unit at or below design conditions? Is AUX relay (terminals 70 & 71) operating during cooling to turn on the drycooler?

9.5.3 Humidity Level Alarms

The humidity alarm may be activated under the following conditions:

- High: The room return air humidity exceeds the pre-set high humidity alarm setpoint. Is the unit set up for dehumidification? Check DIP switch.
- Low: The room return-air humidity is below the low-humidity alarm setpoint. Is the unit set up for humidification? Check DIP switch.
- High and Low Humidity (simultaneously): The simultaneous display of two alarms results in loss of the humidity input signal, and dashes (- - -) are displayed for the humidity reading on the display. If this condition occurs, the control system deactivates both humidification and dehumidification. Check for a disconnected cable or failed sensor.

NOTE: Check for proper setpoints. Does the room have a vapor barrier to seal it from outdoor humidity? Are doors or windows open to outside air?

9.5.4 Temperature Level Alarms

The temperature level alarm may be activated under the following conditions:

- High: Room return air temperature increases to the high temperature alarm setpoint. Check for proper setpoint value. Is the room load more than the unit can handle (unit capacity is too small)? Make sure cooling components are operating (compressor or valves).
- Low: The room return air temperature decreases to the low temperature alarm setpoint. Check for proper setpoint value. Make sure all heating components are operating (contactors, reheats, etc.). Are reheats drawing the proper current (refer to amp rating on nameplate)?
- High and Low Simultaneously: The simultaneous display of the two alarms results in loss of the temperature input signal (or the humidity is out of sensor range-15 to 85% RH), and dashes (---) are displayed for the temperature reading on the display. If this condition occurs, the control system initiates 100% cooling. Check for a disconnected cable or a failed sensor.

NOTE: Check for proper setpoints. Does the room have a vapor barrier to seal it from outdoor humidity? Are doors or windows open to outside air?

9.5.5 Humidifier Problem Alarm

The Humidifier Problem alarm sounds and displays a message if any of the humidifier conditions described in **Table 9.10** below, occur. The humidifier's control board fault indicator LED assists in determining the issue.

Table 9.10 Humidifier Faults and LED indicator

Fault Condition	LED Indicator
Overcurrent detection	Lit constant
Fill system fault	1-second flash
Replace tank	1/2-second flash

9.5.6 Loss of Power Alarm

The Loss of Power alarm activates (after power is restored to the unit) if the unit has lost power or the disconnect switch was incorrectly turned off before the unit's On switch was pressed. A Liebert® remote monitoring unit (optional) will immediately indicate loss of power.

9.5.7 Short Cycle Alarm

A Short Cycle alarm occurs if the compressor system exceeds 10 cooling start attempts in a one-hour period. This may happen if the refrigerant level is low or if the cooling load is small compared to the unit's capacity. Check for leaks, crimped lines and defective components. If the cooling load is low, increase sensitivity to reduce cycle.

This page intentionally left blank

10 MAINTENANCE

Use copies of the [Preventive Maintenance Checklist](#) on page 97 to record preventive maintenance inspections.



WARNING! Arc flash and electric shock hazard. Open all local and remote electric power supply disconnect switches, verify with a voltmeter that power is Off and wear appropriate, OSHA approved personal protective equipment (PPE) per NFPA 70E before working within the electric control enclosure. Failure to comply can cause serious injury or death. Customer must provide earth ground to unit, per NEC, CEC, and local codes, as applicable. Before proceeding with installation, read all instructions, verify that all the parts are included and check the nameplate to be sure the voltage matches available utility power. The Liebert® controller does not isolate power from the unit, even in the Unit Off mode. Some internal components require and receive power even during the Unit Off mode of the controller. The only way to ensure that there is NO voltage inside the unit is to install and open a remote disconnect switch. Refer to unit electrical schematic. Follow all local codes.



WARNING! Risk of electric shock. Can cause equipment damage, injury, or death. Open all local and remote electric power supply disconnect switches and verify with a voltmeter that power is off before working within any electric connection enclosures. Service and maintenance work must be performed only by properly trained and qualified personnel and in accordance with applicable regulations and manufacturers' specifications. Opening or removing the covers to any equipment may expose personnel to lethal voltages within the unit even when it is apparently not operating and the input wiring is disconnected from the electrical source.



WARNING! Risk of improper wiring, piping, moving, lifting and handling. Can cause equipment damage, serious injury or death. Installation and service of this equipment should be done only by qualified personnel, wearing appropriate, OSHA approved PPE, who have been specially trained in the installation of air conditioning equipment.

The Liebert® DataMate units are single components in the facility heat removal system. The system includes air distribution (duct systems), heat rejection (condensing units or chilled water), and indoor cooling and humidity loads (equipment load, location, outside air infiltration). Proper application and maintenance of the entire system is critical to the life and reliability of the thermal management units.

- Good maintenance practices are essential to minimizing operation costs and maximizing product life.
- Read and follow monthly and semi-annual maintenance schedules included in this manual. These MINIMUM maintenance intervals may need to be more frequent based on site-specific conditions.
- We recommend the use of trained and authorized service personnel, extended service contracts and factory-specified replacement parts. Contact your Vertiv sales representative.

10.1 System Testing



WARNING! Arc flash and electric shock hazard. Open all local and remote electric power supply disconnect switches, verify with a voltmeter that power is Off and wear appropriate, OSHA approved personal protective equipment (PPE) per NFPA 70E before working within the electric control enclosure. Failure to comply can cause serious injury or death. Customer must provide earth ground to unit, per NEC, CEC, and local codes, as applicable. Before proceeding with installation, read all instructions, verify that all the parts are included and check the nameplate to be sure the voltage matches available utility power. The Liebert® controller does not isolate power from the unit, even in the Unit Off mode. Some internal components require and receive power even during the Unit Off mode of the controller. The only way to ensure that there is NO voltage inside the unit is to install and open a remote disconnect switch. Refer to unit electrical schematic. Follow all local codes.



WARNING! Risk of contact with high-speed moving parts. Can cause injury or death. Open all local and remote electric power-supply disconnect switches, verify with a voltmeter that power is off, and verify that all the fan blades have stopped moving before working in the unit.

10.1.1 Environmental Control Function Tests

The performance of all control circuits can be tested by changing the setpoints, which actuates each of the main functions.

10.1.2 Cooling Test

To test the cooling function, set the setpoint to a temperature of 10°F (5°C) below room temperature. A call for cooling should register and prompt the equipment to begin cooling cycle. (Disregard any temperature alarms.) Upon completion of testing, return the setpoint to the desired temperature.

10.1.3 Heating Test

Test reheat by setting the setpoint to 10°F (5°C) above room temperature. A call for heating should register and prompt the equipment to begin heating cycle. (Disregard any temperature alarms.) Upon completion of testing, return the setpoint to the desired temperature.

10.1.4 Humidification Test

To check humidification, set the humidity setpoint at 10% RH above the room humidity reading. After a short delay, the canister will fill with water and steam will be produced. Upon completion of testing, return the humidity setpoint to the desired humidity.

10.1.5 Dehumidification Test

Test dehumidification by setting the humidity setpoint at 10% RH below room relative humidity. The compressor should turn on. Upon completion of testing, return the humidity setpoint to the desired humidity.

10.1.6 Remote Shutdown Test

A connection point is provided for remote shutdown devices supplied by the customer. This terminal strip is on the printed circuit board. (Terminals are fitted with a jumper when no remote shutdown device is installed.)

10.2 Filter Maintenance

Experience shows that filters are usually the most neglected item in an environmental control system. In order to maintain efficient operation, they should be checked monthly and washed as required.

NOTE: Always turn power Off before removing filters.

The washable filter is located behind the front access panel on the lower-front on the evaporator.

10.3 Electric Panel Maintenance

Inspect the electric panel on a semi-annual basis for any loose electrical connections.

10.4 Direct Drive Blower Package Maintenance

Inspect the blower package monthly including: motor mounts, fan bearings and impellers.

10.4.1 Fan Impeller and Motor Bearing Maintenance

Inspect fan impellers thoroughly and remove any debris. Check to see if the impellers are tightly mounted on the fan shaft and that they do not rub against the fan housing during rotation. Although the unit's motor bearings are permanently sealed and self-lubricating, inspect them monthly for signs of wear.

10.4.2 Air Distribution Inspection

Because all unit models are designed for constant volume air delivery, any unusual restrictions within the air circuit must be avoided.

10.5 Electric Reheat Maintenance

Reheat element sheets and fins are manufactured with stainless steel. Regular inspections are necessary to assure proper cleanliness of the reheating element. If inspection reveals corrosion particles on the reheating element or adjoining surfaces (including ducts and plenums), perform appropriate cleaning. Periodic replacement of the reheating element may be necessary to meet specific application requirements.

10.6 Refrigeration System Maintenance

Inspect the components of the refrigeration system monthly for proper function and signs of wear. Because evidence of malfunction is typically present before component failure, periodic inspections are a major factor in the prevention of most system failures. Refrigerant lines must be properly supported and not allowed to vibrate against ceilings, floors, or unit frame. Inspect all refrigerant lines every six months for signs of wear and proper support. Inspect the capillary and equalizer lines from the expansion valve.

10.6.1 Refrigeration Suction Pressure

Suction pressure will vary with load conditions. Suction pressure normally ranges from 58 psi to 75 psi (405 kPa to 517 kPa).

10.6.2 Refrigeration Discharge Pressure

The discharge pressure will vary greatly with load and ambient conditions, see **Table 10.1** on the next page. The high pressure switch shuts down the compressor at its cutout setting.

Table 10.1 Typical Discharge Pressures

System Design	Discharge Pressure, psig (kPa)
Air Cooled	200-300 (1,380-2,070)
Water Cooled 65 to 85°F water (18 to 29.4°C)	200-250 (1,380-1,725)
Glycol Cooled	250-350 (1,725-2,415)
High Pressure Cutout	400 (2,760)

10.6.3 Thermostatic Expansion Valve (TXV) Maintenance

The TXV performs one function: It keeps the evaporator supplied with enough refrigerant to satisfy load conditions. It does not affect compressor operation.

Proper valve operation can be determined by measuring superheat. The correct superheat setting is between 10 and 15°F (5.6 and 8.3°C). If too little refrigerant is being fed to the evaporator, the superheat will be high. If too much refrigerant is being supplied, the superheat will be low.

10.6.4 Air Cooled Condensing Unit Maintenance

Restricted airflow will reduce operating efficiency and could result in high compressor head pressure and loss of cooling.

- Clear coil surface of all debris that will inhibit airflow.
- Check for bent or damaged coil fins and correct.
- Do not permit snow to accumulate around or under outdoor unit.
- Periodically consider commercial cleaning of coil surface
- Inspect fans, motors and controls for proper operation.
- Check all piping and capillaries for vibration and proper support.
- Inspect all refrigerant lines for signs of oil leaks.
- Check contactors for pitting. Replace if pitted.

10.6.5 Hot Gas Bypass Operation and Maintenance

When applying hot gas bypass with split system condensing units, bypassing discharge gas to the compressor suction line offers more flexibility than conventional hot gas bypass to the evaporator unit.

The hot gas bypass valve is installed between the compressor discharge piping and suction piping, bypassing the condenser and evaporator coils. The discharge gas mixes with the suction gas, raising the suction temperature and pressure and decreasing the mass flow through the evaporator. The higher suction temperatures could cause compressor overheating, therefore a separate, liquid quenching valve is provided to mix refrigerant from the system liquid line with the discharge gas before mixing with the suction gas entering the compressor.

During normal operation, when the evaporator is under full load, the hot gas bypass equalizer pressure will remain high enough to keep the valve port closed. If the evaporator load decreases, the evaporator temperature and pressure will drop. When the suction pressure reduces below the hot gas-bypass valve setting the hot gas bypass valve opens diverting some of the refrigerant flow back to the compressor suction. The liquid quenching valve bulb senses this increased superheat and opens, allowing liquid refrigerant to mix with the discharge gas, de-superheating it.

Proper mixing of the three refrigerant paths ensures stable operation and system performance. The liquid quenching valve bulb must be located downstream of all these connections to control superheat at the compressor inlet. Superheat settings for the liquid quenching valve are chosen to maintain consistency with the system expansion valve. During hot gas bypass operation, higher superheats, 50 to 60°F (28 to 33°C), may be observed at the compressor. The liquid quenching valve is internally equalized and superheat is not adjustable.

Figure 10.1 Hot Gas Bypass Components and Flow

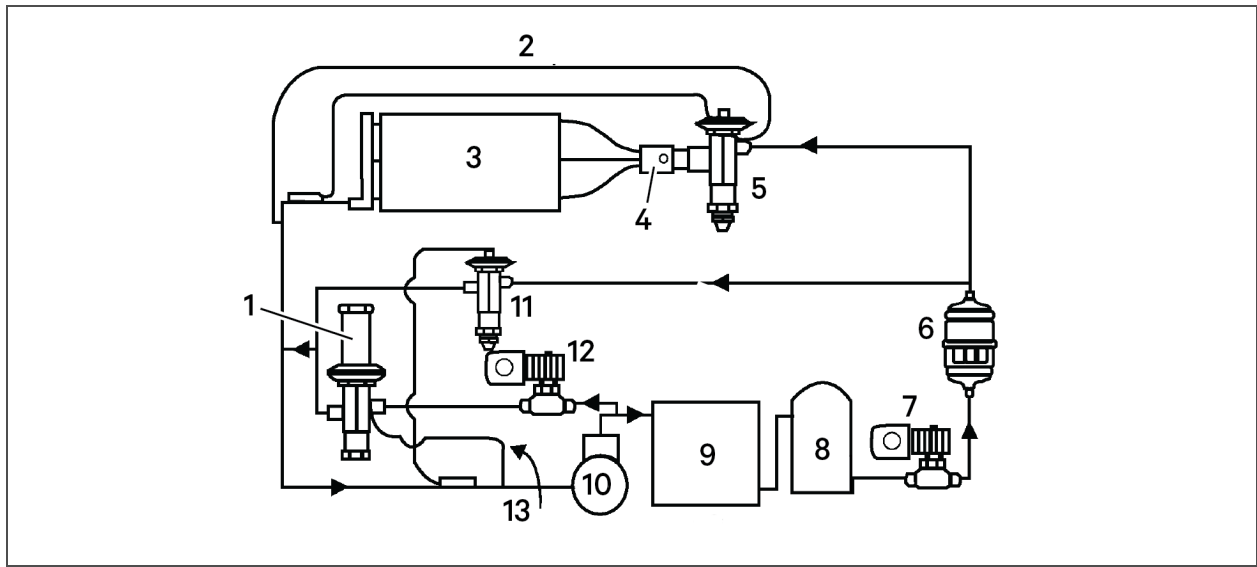

Item	Description
1	Discharge bypass valve
2	External equalizer
3	Evaporator
4	Distributor
5	TEV
6	Catch-all
7	Solenoid valve
8	Receiver
9	Condenser coil
10	Compressor
11	De-superheating TEV
12	Hot gas solenoid valve
13	External equalizers

To adjust hot gas bypass:

1. Install the suction and discharge pressure gauge.
2. Adjust temperature setpoint to call for cooling so that the refrigeration compressor will run continuously.
3. Remove the TOP adjusting nut from the valve.

4. Insert an Allen wrench in the brass hole at top of valve in adjusting port, and turn CLOCKWISE if a higher evaporator temperature is required. Adjust no more than 1/4 turn at a time. Let the system stabilize for 15 minutes before determining if additional adjustment are necessary.
5. After obtaining the suction pressure required, reinstall cap tightly making sure there are no leaks.
6. Let the evaporator operate for approximately 10 to 15 minutes to make sure the suction pressure is within the range desired.
7. There may be a fluctuation of approximately 3 to 6 psig (21 to 41 kPa) on the evaporator due to the differential on the hot gas bypass.
8. Return temperature setpoint to the desired setting.

10.6.6 Water/Glycol Condenser Maintenance

The DMC module has a compact, brazed plate condenser, and the MCD water/glycol cooled condensing unit has a coaxial condenser. Clean the screen on the field installed Y-strainer (if installed. Highly recommended for DMC modules with brazed plate condensers). If the water supply is clean, coaxial condensers do not normally require maintenance or replacement. If your system begins to operate at high head pressure with reduced capacity and all other causes have been eliminated, the condenser may be obstructed or fouled and should be cleaned or replaced.

10.6.7 Regulating Valve Maintenance (Water/Glycol Cooled Condensers Only)

The water regulating valve automatically regulates the amount of fluid necessary to remove the heat from the refrigeration system, permitting more fluid to flow when load conditions are high and less fluid to flow when load conditions are low. The valve consists of a brass body, balance spring, valve seat, valve disc holders, capillary tube to discharge pressure and adjusting screw.

The water regulating valve begins opening at 180 psig (1,240 kPag) and is fully opened at 240 psig (1,655 kPag). The valve is factory set and should not need adjustment. There is significant difference in the way standard pressure and high pressure valves are adjusted. Consult Vertiv technical support.

10.6.8 Glycol Solution Maintenance

It is difficult to establish a specific schedule of inhibitor maintenance because the rate of inhibitor depletion depends upon local water conditions. Analysis of water samples at the time of installation and through a maintenance program should help to establish a pattern of depletion. A visual inspection of the solution and filter residue is often helpful in judging whether active corrosion is occurring.

The complexity of water/glycol solution condition problems and the variations of required treatment programs make it extremely important to obtain the advice of a competent and experienced water treatment specialist and follow a regularly scheduled coolant fluid system maintenance program. It is important to note that improper use of water treatment chemicals can cause problems more serious than using none. Proper inhibitor maintenance must be performed in order to prevent corrosion of the glycol system. Consult the glycol manufacturer for testing and maintenance of inhibitors. Do not mix products from different manufacturers.

10.7 Compressor Maintenance



WARNING! Risk of over-pressurization of the refrigeration system. Can cause piping rupture, explosive discharge of high pressure refrigerant, loss of refrigerant, environmental pollution, equipment damage, injury, or death. This unit contains fluids and gases under high pressure. Use extreme caution when charging the refrigerant system. Do not pressurize the system higher than the design pressure marked on the unit's nameplate. Relieve pressure before cutting into or making connections/disconnections to the piping system. Local building or plumbing codes may require installing a pressure relief device in the system.

Consult local building and plumbing codes for installation requirements of additional pressure relief devices when isolation valves are field installed. Do not isolate any refrigerant circuits from over-pressurization protection. The PFH and MCD condensing units include a factory installed pressure relief valve mounted on top of the receiver. The valve is rated for a maximum working pressure of 475 psig.



CAUTION: Risk of contacting caustic substances. Can cause injury. Avoid touching or contacting the gas and oils with exposed skin. Severe burns will result. Wear appropriate, OSHA approved PPE when handling contaminated parts.

Infrequently, a fault in the motor insulation may result in a motor burnout (if system is properly installed, motor burnout rarely occurs). Primarily, this type of failure is due to mechanical or lubrication problems, where the burnout is a secondary consequence.

Early detection can prevent a large percentage of the problems that can cause compressor failures. Periodic maintenance inspections that identify abnormal operation can be a major factor in reducing maintenance costs. It is easier and more cost effective to implement the necessary preventative steps that ensure proper system operation, rather than ignore a problem until it results in compressor failure and costly replacement. When troubleshooting a compressor problem, check all electrical components for proper operation:

- Check all fuses and circuit breakers.
- Check pressure switch operation.
- If a compressor failure has occurred, determine whether its cause is an electrical or mechanical problem.

10.7.1 Mechanical Failure of the Compressor

If you determine that a mechanical failure has occurred, the compressor must be replaced. If a burnout occurs, correct the problem and clean the system. It is important to note that successive burnouts of the same system are usually caused by improper cleaning. If a severe burnout has occurred, the oil will be black and acidic.

10.7.2 Electrical Failure of the Compressor

In the event of an electrical failure and subsequent burnout of the refrigeration compressor motor, proper procedures must be followed to thoroughly remove any acids that would cause a future failure. There are two kits that can be used with a complete compressor burnout - Sporlan System Cleaner and Alco Dri-Kleener. Follow the manufacturer's procedure.

NOTE: Damage to a replacement compressor due to improper system cleaning constitutes abuse under the terms of the warranty, thereby voiding the warranty.

10.7.3 Replacement Compressors

Replacement compressors are available from your Vertiv supplier and are shipped to the job site in a reusable crate (as required by the service contractor). If the compressor is under warranty, you must return it to Vertiv, to receive proper warranty credit. Return it in the same container in which the replacement compressor was shipped. Record the possible cause(s) or condition(s) of the damage on the provided return tag.

10.7.4 Replacing a Failed Compressor

1. Disconnect power.
2. Attach suction and discharge gauges to access fittings.
3. Recover refrigerant using standard recovery procedures and equipment. Use a filter drier when charging the system with recovered refrigerant.

NOTE: Release of refrigerant to the atmosphere is harmful to the environment and unlawful. Refrigerant must be recycled or discarded in accordance with federal, state, and local regulations.

4. Remove failed compressor.
5. Install replacement compressor and make all connections.
 - Use a flow of dry nitrogen through the piping during brazing to prevent formation of copper oxide scale inside the piping. Copper oxide forms when copper is heated in the presence of air. POE oil will dissolve these oxides from inside the copper pipes and deposit them throughout the system, clogging filter driers and affecting other system components.
 - A pure dry nitrogen flow of 1-3 ft³/min (0.5-1.5 l/s) inside the pipe during brazing is sufficient to displace the air. Control the flow using a suitable metering device. Pressurize and leak test the system at approximately 150 psig (1,034 kPa) pressure.
6. Follow manufacturer's instructions for clean-out kits.
7. Evacuate the system twice to 500 microns. Break the vacuum each time with clean, dry nitrogen.
8. Evacuate the system a third time to 500 microns.
9. Charge the system with refrigerant (R-407C) based on requirements of the evaporator, condensing unit, and lines. Refer to the unit nameplate.
10. Apply power and operate the system. Check for proper operation. Refer to **Table 10.1** on page 88.

10.8 Steam Generating Humidifier Maintenance

The humidifier drains and refills to maintain a current setpoint and alert the operator when the humidifier canister needs to be replaced.



WARNING! Arc flash and electric shock hazard. Open all local and remote electric power supply disconnect switches, verify with a voltmeter that power is Off and wear appropriate, OSHA approved personal protective equipment (PPE) per NFPA 70E before working within the electric control enclosure. Failure to comply can cause serious injury or death. Customer must provide earth ground to unit, per NEC, CEC, and local codes, as applicable. Before proceeding with installation, read all instructions, verify that all the parts are included and check the nameplate to be sure the voltage matches available utility power. The Liebert® controller does not isolate power from the unit, even in the Unit Off mode. Some internal components require and receive power even during the Unit Off mode of the controller. The only way to ensure that there is NO voltage inside the unit is to install and open a remote disconnect switch. Refer to unit electrical schematic. Follow all local codes.



WARNING! Risk of improper wiring, piping, moving, lifting and handling. Can cause equipment damage, serious injury or death. Installation and service of this equipment should be done only by qualified personnel, wearing appropriate, OSHA approved PPE, who have been specially trained in the installation of air conditioning equipment.



WARNING! Risk of smoke and fire. Can cause activation of fire suppression systems, building evacuation, dispatching of fire/rescue equipment and personnel and catastrophic canister failure resulting in water leaks, equipment damage, injury or death. Using a humidifier canister that has reached the end of its service life can be extremely hazardous. If the canister cannot be replaced immediately at the end of life condition, turn Off the power and water supply to the humidifier and remove the canister until a replacement canister can be installed. Do not ignore humidifier problem alarms. Resetting humidifier without addressing cause may result in fire or damage due to leaking water.



CAUTION: Risk of contact with hot surfaces. Can cause burn injury. The humidifier canister and steam discharge lines are extremely hot during operation. Allow sufficient time for them to cool to a touch-safe temperature before handling. Use extreme caution and wear appropriate, OSHA approved PPE when performing maintenance on the humidifier.

After an extended period of operation, in accordance with life expectancy information, the cylinder is completely used as indicated by the amber high water sensor light illuminated on the cabinet. When this condition is reached, a new replacement cylinder must be installed.

NOTE: The amber high water sensor light may come on during initial start-up, but this instance does not indicate that the cylinder should be replaced.

The steam cylinder is disposable and must be replaced at the end of the cylinder's life. Cylinder life will vary according to water supply conditions and humidifier use.

10.8.1 Operating the Humidifier

1. During start-up, when the humidity control calls for humidification, the fill valve opens and allows water to enter the canister. When the water level reaches the electrodes, current flows and the water begins to warm. The canister fills until the amperage reaches the setpoint and the fill valve closes. As the water warms, its conductivity increases and the current flow, in turn, rises. If the current reaches 115% of the normal operating current, the drain valve opens and drains some of the water out of the canister. This reduces electrode contact with the water and lowers the current flow to the amperage setpoint. Boiling soon commences, and the canister operates normally.
2. If the conductivity of the water is low, the canister fills and the water level reaches the canister full electrode before the current setpoint is reached. The humidifier stops filling to prevent overflow. Boiling should commence in time. As water is boiled off, the mineral concentration in the canister increases and current flow also increases. The canister eventually reaches full output and goes to normal operation. No drain is permitted until then.
3. When full output is reached the circuit board starts a time cycle which is factory set at 60 seconds. During this repeating time cycle, the fill valve will open periodically to replenish the water being boiled off and maintain a steady state output at the setpoint. The amperage variance depends on the conductivity of the water.

4. After many cycles, the mineral concentration in the canister becomes too high. When this occurs, the water boils too quickly. As the water quickly boils off and less of the electrode is exposed, the current flow decreases. When the current crosses the low threshold point before the end of the time cycle, the drain valve opens, draining the mineral laden water out and replacing it with fresh water. This lowers the mineral concentration and returns the canister to steady state operation and prolongs canister life. The frequency of drains depends on water conductivity.
5. Over a period of time, the electrode surface becomes coated with a layer of insulating material, which causes a drop in current flow. As this happens, the water level in the canister will slowly rise exposing new electrode surface to the water to maintain normal output. Eventually, the steady state water level will reach the canister full electrode and indicate so by activating the canister full alarm and opening the humidifier contactor. At this point, all of the electrode surface has been used up and the canister must be replaced.
6. After the entire electrode surface has been coated, the output will slowly begin to fall off. This usually occurs in the last several hours of electrode life and should allow enough time to schedule maintenance. During these last hours, the mineral concentration can increase. If the mineral concentration is too high, arcing can occur. If the electrodes start to arc, turn off the humidifier immediately and replace the canister with the identical part.

10.8.2 Replacing the Canister

The humidifier RUN/DRAIN switch is located in the humidifier assembly. This switch should be in the RUN position when the humidifier is in normal operation. It should be in the DRAIN position when a manual drain for service is required. The electronic control board for the humidifier is located in the same area as the humidifier assembly. When the unit is energized, power is available to the humidifier circuits.

1. Turn off the humidifier by lowering the humidity setpoint below the ambient humidity level.
Record the original setpoint.
2. Place the RUN/DRAIN switch in the DRAIN position to drain the water from the canister.
3. Return the RUN/DRAIN switch to the RUN position after the canister has drained.
4. Turn Off the power at the main unit.
5. Remove the cover from the humidifier cabinet
6. Locate the power wires to the steam canister. They are connected to the canister with 1/4-in. quick connects. Make note of the wiring configuration before removing any wires. Refer to the schematic on the unit. Slide the rubber boot back to expose the connections. Remove the two power wires and the canister wire. Do not loosen the screws that secure the electrodes.
7. Loosen the steam outlet hose clamps and slide the steam hose away from the canister fitting.
8. Release the canister clamp along the base of the canister.

The canister is now ready to be removed.
9. Remove the canister.
10. Reverse these steps to replace the canister, taking special note of the following:
 - When replacing wiring, connect the red wire from terminal #1 on the interface to the red tip terminal on the canister. Reconnect the power wires as they were formerly connected (#2 on the left and #1 on the right).
 - Always check the fill and drain solenoids for proper operation after replacing the canister.

10.8.3 Circuit Board Adjustments

Humidifier operation is governed by the humidifier control board. There are three potentiometers mounted on the board. These pots can be used to adjust for extreme water conductivity conditions and capacity.

The POT labeled % controls the amperage at which the drain will energize. The pot is clearly marked in percentages. This adjustment is factory set at 70%, which indicates that the unit will drain when the amperage decreases to 70% of the capacity setpoint. Raising the value increases the frequency of drain cycles. Lowering the value decreases the frequency of drain cycles. The frequency should be increased for highly conductive water and decreased for less conductive water. If adjustment is necessary and a change of three to four percent in either direction does not permit normal operation of the unit, consult your Vertiv supplier.

The POT labeled sec controls the duration of the drain cycle. This is factory set at 60 seconds and should not be readjusted without consulting your Vertiv supplier.

The POT labeled cap adj controls the capacity of the humidifier. It is factory set at 65%. Adjust if more humidity is required.

NOTE: If condensation occurs on the discharge grille, reduce the humidifier capacity.

This page intentionally left blank

11 PREVENTIVE MAINTENANCE CHECKLIST

Source: DPN002953, Rev 2

Inspection Date	Job Name
Indoor Unit Model #	Indoor Unit Serial Number #
Condensing Unit Model #	Condensing Unit Serial #
Room Temperature/Humidity ° %	Ambient Temperature °

Not all units will have all components. To determine your unit's configuration, compare the Indoor Unit Model # above and the information in the Components and Nomenclature section.

Good maintenance practices are essential to minimizing operation cost and maximizing product life. Read and follow all applicable maintenance checks listed below. At a minimum, these checks should be performed semi-annually. However, maintenance intervals may need to be more frequent based on site-specific conditions. Review the unit user manual for further information on unit operation. We recommend the use of trained and authorized service personnel, extended service contracts, and factory certified replacement parts. Contact your local sales representative for more details.

Check all that apply:

Evaporator/Filters

1. Check/Replace filters.
2. Ensure grille area is unrestricted.
3. Wipe section clean.
4. Make sure that the coil is clean.
5. Clean the condensate pan.
6. Clean the trap in the condensate drain.
7. Check that the drain connection/lines are open, leak free and in good condition.
8. Check/Test the filter clog switch operation (If equipped).
9. Check/Test the condensate drain pan float switch operation (If equipped).

Blower Section

1. Make sure that the blower wheels are free of debris.
2. Check the motor mount.
3. Check the motor amp draw.

L1 _____ L2 _____ L3 _____

- Compare to nameplate amps.

Reheat (If Equipped)

1. Inspect elements and check for corrosion.
2. Check/Re-torque wire connections (inside reheat box).
3. Check the reheat amp draw.

L1 _____ L2 _____ L3 _____

(L1 and L2 on single phase units)

Steam Generating Humidifier (If Equipped)

1. Check the drain valve/drain lines/trap for clogs.
2. Check the water fill valve and all hoses for leaks.
3. Check the condition of the steam hose.
4. Check the canister for mineral deposits.
5. Check the condition of the electrodes.
6. Clean the strainer.
7. Replace the humidifier bottle, if necessary.
8. Check the operation of the humidifier.
9. Check the humidifier amp draw .

L1 _____ L2 _____ L3 _____

(L1 and L2 on single-phase units)

Condensate Pump (If Equipped)

1. Check for debris in the sump.
2. Check the operation of the float(s) (free movement).
3. Check/Clean the discharge check valve.
4. Check the drain connection/lines for leaks.

Overflow Drain Pan (Ducted Units - If Equipped)

1. Make sure that the drain connection and lines are open and free of debris.
2. Check that the drain line empties into a maintenance sink or condensate pump.
3. Check that the water detection device/system is installed and monitored Check operation (If installed).

Electrical Panel

1. Check fuses.
2. Check contactors for pitting (replace if pitted).
3. Check/Re-torque wire connections.

Controls

1. Check/Verify control operation (sequence).
2. Check/Test changeover device(s) (if equipped).
3. Check/Test water detection device(s) (if equipped).

Refrigeration Piping

1. Check refrigerant lines (clamps secure/no rubbing/no leaks).
2. Check for moisture (sight glass).
3. Check for restriction temperature drop across filter drier.

Compressor Section

1. Check the oil level.
 2. Check for oil leaks.
 3. Check the compressor mounts (springs/bushings).
 4. Check the cap tubes (not rubbing).
 5. Check/Re-torque the wire connections (inside compressor box).
 6. Check the compressor operation (vibration/noise).
 7. Check the crank case heater fuses/operation (if equipped).
 8. Check for refrigerant leaks.
 9. Suction pressure _____
 10. Discharge Pressure _____
 11. Superheat _____
 12. High pressure cut out _____
 13. Compressor amp draw _____
- L1 _____ L2 _____ L3 _____
- (L1 and L2 on single phase units)

Air Cooled Condensing Unit (If Equipped)

1. Ensure that the coil is clean/free of debris .
 2. Check that the motor mounts are tight.
 3. Check that the bearings are in good condition.
 4. Make sure that the refrigerant lines are properly supported.
 5. Check the motor amp draw.
- L1 _____ L2 _____ L3 _____
- (L1 and L2 on single phase units)

Water/Glycol Cooled Condenser (If Equipped)

6. Check the water regulating valve operation.
7. Verify that water flow/continuous flow is maintained.
8. Clean the screen on the Y-strainer (if equipped).
9. Make sure thate the cap tubes are not rubbing.
10. Check for water/glycol leaks.
11. Entering water temperature _____°
12. Leaving water temperature _____°

12 TROUBLESHOOTING



WARNING! Risk of electric shock. Can cause injury or death. Open all local and remote electrical power disconnect switches and verify with a voltmeter that power is off before working within electrical enclosures. Hazardous voltage will be present at evaporator, condensing unit, reheat and humidifier even with the unit turned Off at the control panel. With power and controls energized, the unit could begin operating automatically without warning.

Table 12.1 on the next page, describes the possible causes, and actions to take when troubleshooting an issue.

Table 12.1 Troubleshooting

Symptom	Possible Causes	Check or Remedy
Unit will not start	No power to unit	Check voltage at input terminal block.
	Control voltage circuit breaker (at transformer) open	Locate short and reset circuit breaker.
	Float switch relay has closed due to high water in the condensate pan.	Check drain and line as well for failed pump. Access through left panel. Power must be cycled at the disconnect to reset.
	Jumper not in place	Check terminal 37 and 38 for jumper or N/C contact. Check pins P39-1 and P39-2 for jumper or N/C firestat contact.
No cooling	Cooling is not displayed at the control panel.	Adjust TEMP control setpoint and sensitivity to require cooling.
	Short cycle prevention control.	Control software delays compressor 3 minutes cooling, from stop to start.
	Compressor contactor not pulling in.	Check for 24 VAC ± 2 VAC at terminals TB5-1 and TB5-2. If voltage, check contactor.
	Compressor high head pressure.	See below for cause.
	Plugged filter/drier.	Replace filter/drier.
Compressor high head pressure alarm	Low refrigerant charge.	Check pressure gauges. At low ambient temperatures, proper refrigerant charge is very important on units with Lee-Temp receivers.
	Insufficient air flow across condenser coil	Remove debris from coil and air inlets.
	Water/Glycol Cooled only: No fluid flowing through condenser.	Check fluid supply to regulating valve. Clean Y-strainer filter, if installed. Adjust valve if necessary.
Reheat will not operate	Un-shielded control wires used between split system units.	Check for shielded control wires used and for shielded wire connection to earth (ground) at the Liebert® equipment. Route low voltage wires separate from high voltage lines and away from loads such as light ballasts.
	DIP switch not set to enable reheat option	See DIP switch settings 9.2.17 on page 75.
	HEAT not displayed at the control panel	Increase temperature setpoint to require heating.
	Reheat safety open, defective reheat contact or defective board	Check voltage at P2-1 or P2-2 to P34-10 on control board for 24 VAC ± 2 VAC. If voltage, check reheat contactor and reheat safety. If no voltage, check wiring and/or replace board.
	Element is burned out	Turn off power. Check element continuity with Ohm meter.

Table 12.1 Troubleshooting (continued)

Symptom	Possible Causes	Check or Remedy
Display freezes and control pads do not respond	Static discharge	During period of low humidity, static electricity can cause the control program to freeze or display incorrect information. Although this is unlikely, the control can be reset by cycling power from the disconnect switch.
Humidifier does not operate	DIP switch not set to enable humidifier option	See DIP switch settings 9.2.17 on page 75.
	HUMIDIFY not displayed at control panel	Increase humidity control setpoint and sensitivity to require humidification.
	Defective board	Check voltage at P3-1 and P3-2 on interface board for 24 VAC ± 2 VAC. If no voltage, check wiring and/or replace board. Check wiring from control panel to humidifier circuit board.
	Failed humidity sensor	Humidity display will indicate dashes. Check wiring from temperature/ humidity board to the control board and from the wall box to the control board. Replace wall box or temperature/humidity circuit board (if remote).
	No water flow	Make sure switch is in Run position. Check humidifier water supply (including filter screen) and check nylon overflow line if canister is full.
Canister fill rate is not keeping up with the steam output	Canister fill rate is not keeping up with the steam output	Check fill valve screen opening and capillary tube for obstructions. Check water supply pressure (minimum 10 psig [69 kPa]).
	Fan will not operate at low speed when selected from control panel.	Open wiring or failed board
Fan will not operate at low speed during dehumidification	Temperature requirement is too high.	Verify with display. Cooling requirement overrides dehumidification.
Cooling cycle too short	Sensor response delay too short	Increase sensor response delay. See Calibrating Sensors and Setting Sensor Response Delay on page 71.
Condensate pump does not operate	Open or short circuit in wiring	Find open or short circuit and repair power to pump.

Table 12.1 Troubleshooting (continued)

Symptom	Possible Causes	Check or Remedy
Continuous Cooling	Failed temperature sensor	Temperature display will indicate dashes. Check wiring from temperature/humidity board (remote sensors) to the control board or from control board to wall box. Replace temperature/humidity circuit board (remote sensors) or wall box.
Continuous Cooling Dehumidification Humidification	Shorted wiring or failed control board	Check wiring and/or replace control board.
Display	Incorrect wiring	Review the section, Electrical Connection Requirements on page 55. Verify VDC between 5 and 6 volts at TB-3 Pin 1 (ground) and TB-3 Pin 2 of the control board and wall box. If the transmit lines (TB-3 Pins 3 and 4) are not connected, only the power LED will be lit. It will flash once every 10-12 seconds. If T- is connected but not T+, TX1 will flash about every 2-3 seconds, and the power LED will flash once every 10-12 seconds. If T+ and T- are reversed, the power LED and RX1 will be lit and flash every 10-12 seconds. NOTE: Erratic operation of the unit could occur. If no LED is lit, there is no power or the +5 VDC polarity is reversed. If any of these conditions occur, remove power from the evaporator using the disconnect switch, and correct the wiring from the control board to the wall box. NOTE: It may take up to 20 seconds for the display to appear on the wall box LCD after power is applied.

APPENDICES

Appendix A: Technical Support and Contacts

A.1 Technical Support/Service in the United States

Vertiv Group Corporation

24x7 dispatch of technicians for all products.

1-800-543-2378

Liebert Thermal Management Products

1-800-543-2778

Liebert Channel Products

1-800-222-5877

Liebert AC and DC Power Products

1-800-543-2378

A.2 Locations

United States

Vertiv Headquarters

1050 Dearborn Drive

Columbus, OH, 43085, USA

Europe

Via Leonardo Da Vinci 8 Zona Industriale Tognana

35028 Piove Di Sacco (PD) Italy

Asia

7/F, Dah Sing Financial Centre

3108 Gloucester Road, Wanchai

Hong Kong

This page intentionally left blank

Appendix B: Submittal Drawings

Table B.1 Submittal Drawings Contents

Document Number	Title
Planning Dimensions - Evaporators/Chilled Water Units	
DPN000262	Cabinet Dimensions, Evaporator/Chilled Water Unit
DPN000269	Cabinet Dimensions, Evaporator/Chilled Water Unit
Planning Dimensions - Indoor Condensing Units	
DPN004420	Cabinet Dimensions, Air Cooled Units
DPN004421	Cabinet Dimensions, Water/Glycol Cooled Units
Piping General Arrangement	
DPN004406	Piping, Air Cooled Models
DPN004405	Piping, Split System Water/Glycol Models
DPN004403	Piping, Close Coupled Water/Glycol and Chilled Water Models
Piping Connections - Evaporator and Chilled Water Units	
DPN004306	Piping Connections
Condensate Pump Connection	
DPN004306	Field Installed Pump Connection
Piping Connections - Split System Indoor Condensing Units	
DPN004420	Piping Connections, Air Cooled Condensing Unit
DPN004421	Piping Connections, Water/Glycol Cooled Condensing Unit
DPN004309	Piping Connections, Close Coupled Water/Glycol Cooled Units
DPN000264	Electrical Connections, Air Cooled and Chilled Water Units
DPN000271	Electrical Connections, Water/Glycol Cooled Units
DPN004912	Arrangement and Dimensions, IS-UNITY-DP for BMS Communication
DPN004854	Electrical Connections, IS-UNITY-DP for BMS Communication
Electrical Connections - Split System Indoor Condensing Units	
DPN000207	Electrical Connections, Air Cooled
DPN000209	Electrical Connections, Water/Glycol Cooled Units

This page intentionally left blank

LIEBERT DATAMATE

CABINET DIMENSIONAL DATA FAN/COIL & CHILLED WATER MODULE

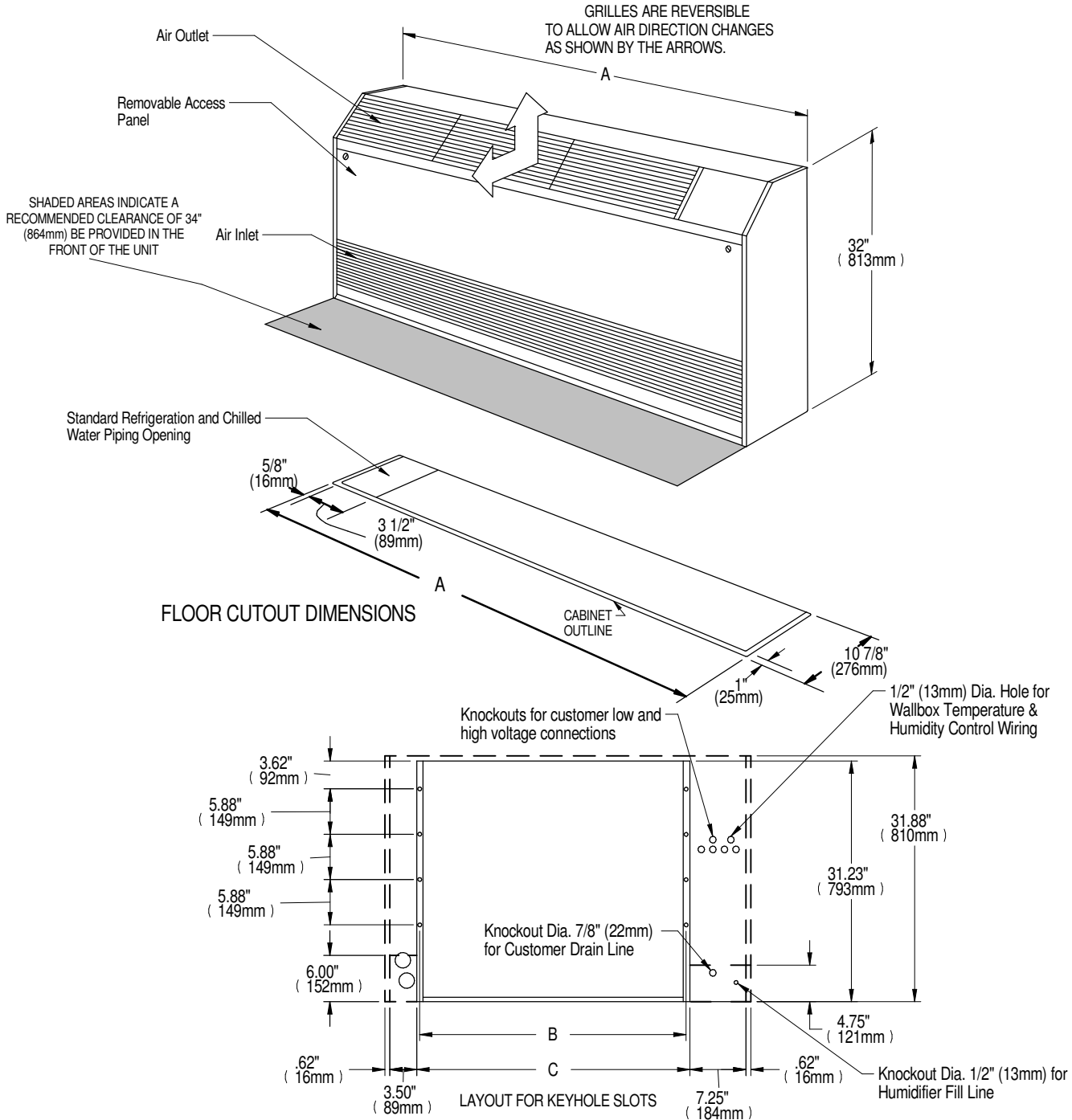

MODEL	DIMENSIONAL DATA in. (mm).			UNIT OPERATING WEIGHT. lbs. (kg)
	A	B	C	
DME020E	46 1/2 (1181)	33 3/4 (857)	34 7/16 (874)	230 (104)
DME027E				330 (150)
DME037E	64 1/8 (1628)	51 1/2 (1308)	52 3/16 (1325)	365 (165)
DME044C				

CABINET DIMENSIONAL DATA WATER/GLYCOL COOLED CONDENSING MODEL

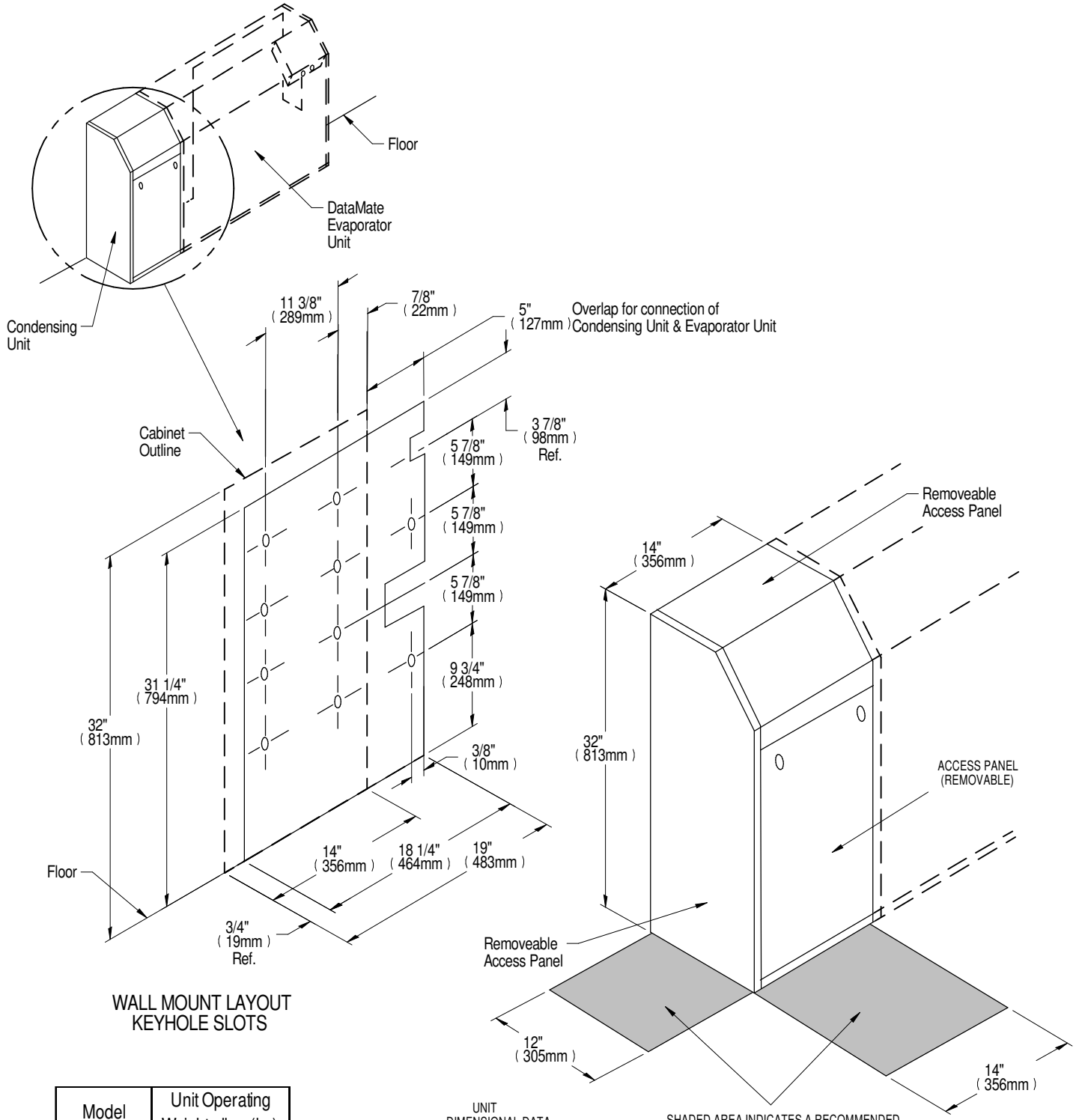

Model	Unit Operating Weight lbs. (kg)
DMC022WG	169 (77)
DMC029WG	172 (78)
DMC040WG	172 (78)

LIEBERT MINI-MATE2

CABINET DIMENSIONAL DATA & PRIMARY CONNECTION LOCATIONS 2 & 3 TON INDOOR CONDENSING MODELS

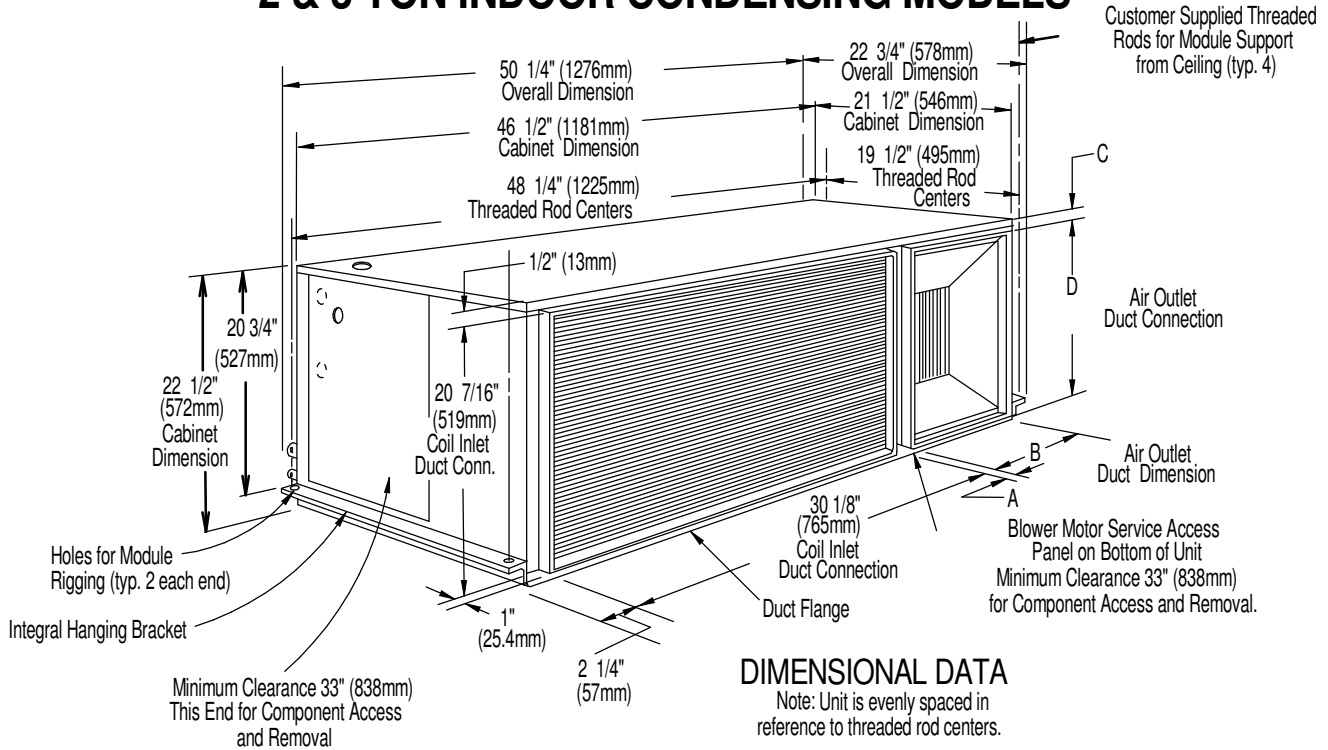

Model #	Dimensions in. (mm)				Unit Net Wt. lbs. (kg)	Refrigeration Connection Sizes O.D. Cu	
	A	B	C	D		Suction	Liquid
MC*24A					230 (104)	5/8"	3/8"
MC*36A	1-7/16 (37)	11-7/16 (290)	1/2 (13)	20-7/16 (519)	240 (109)	7/8"	
MC*35A							
MC*40A							
MC*39A	1-5/8 (41)	11-3/4 (298)	3/4 (19)	20-1/4 (514)			

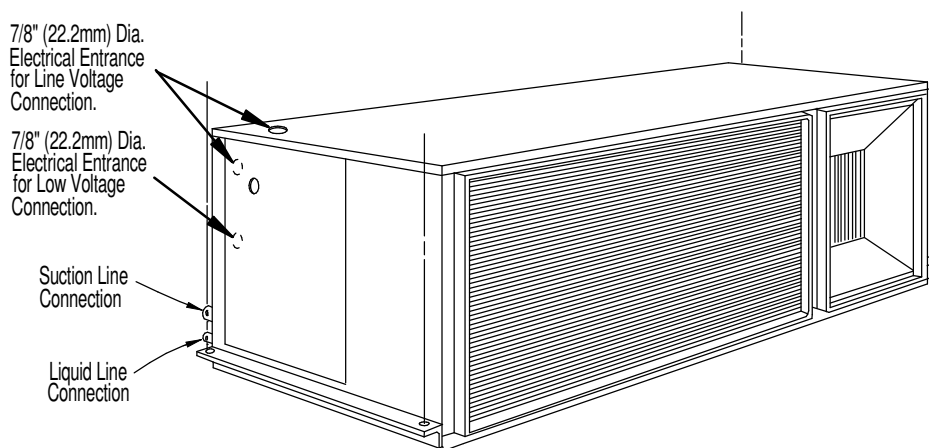

PIPING CONNECTIONS

LIEBERT MINI-MATE2

CABINET DIMENSIONAL DATA & PRIMARY CONNECTION LOCATIONS

2 & 3 TON WATER/GLYCOL COOLED INDOOR CONDENSING MODULE

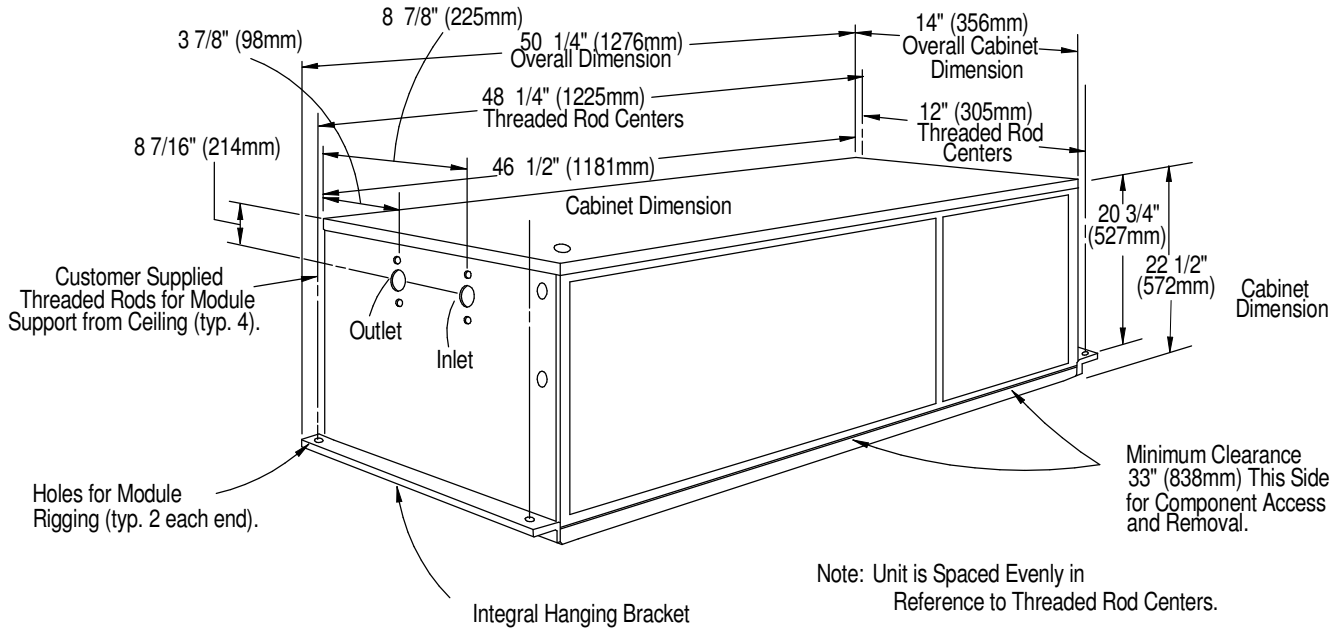

DIMENSIONAL DATA

Model #		Unit Net Weight lbs. (kg)	Refrigerant Connection Sizes O.D. Cu	
60 Hz	50 Hz		Suction	Liquid
MC*26W	N/A	175 (79)	5/8"	3/8"
MC*38W	MC*37W	220 (100)	7/8"	
MC*44W	MC*43W			

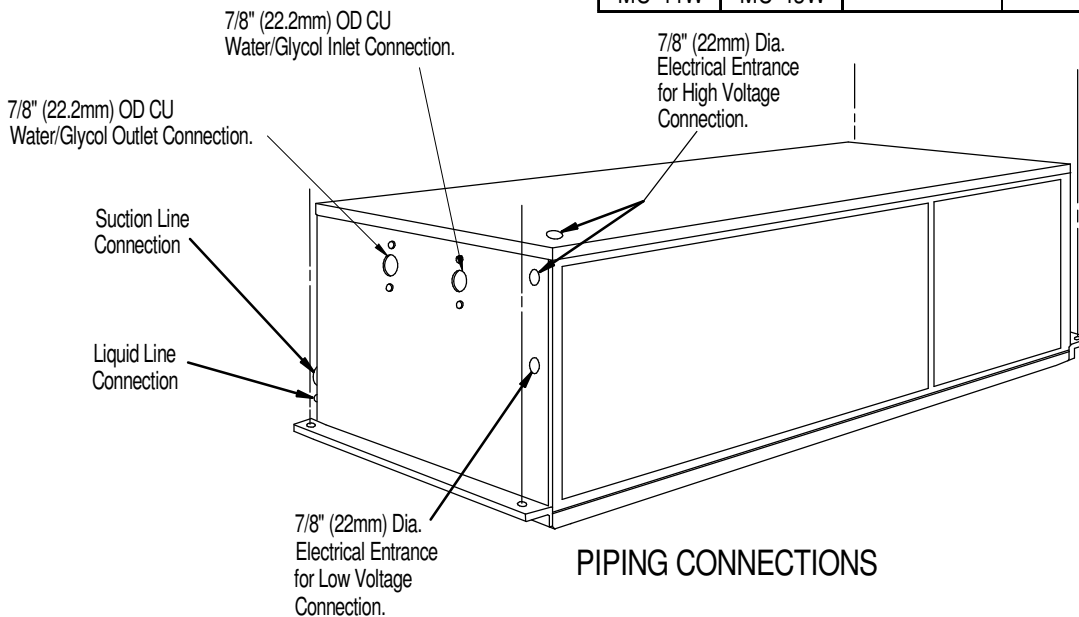

PIPING CONNECTIONS

LIEBERT DATAMATE

GENERAL ARRANGEMENT DIAGRAM SPLIT SYSTEMS AIR COOLED

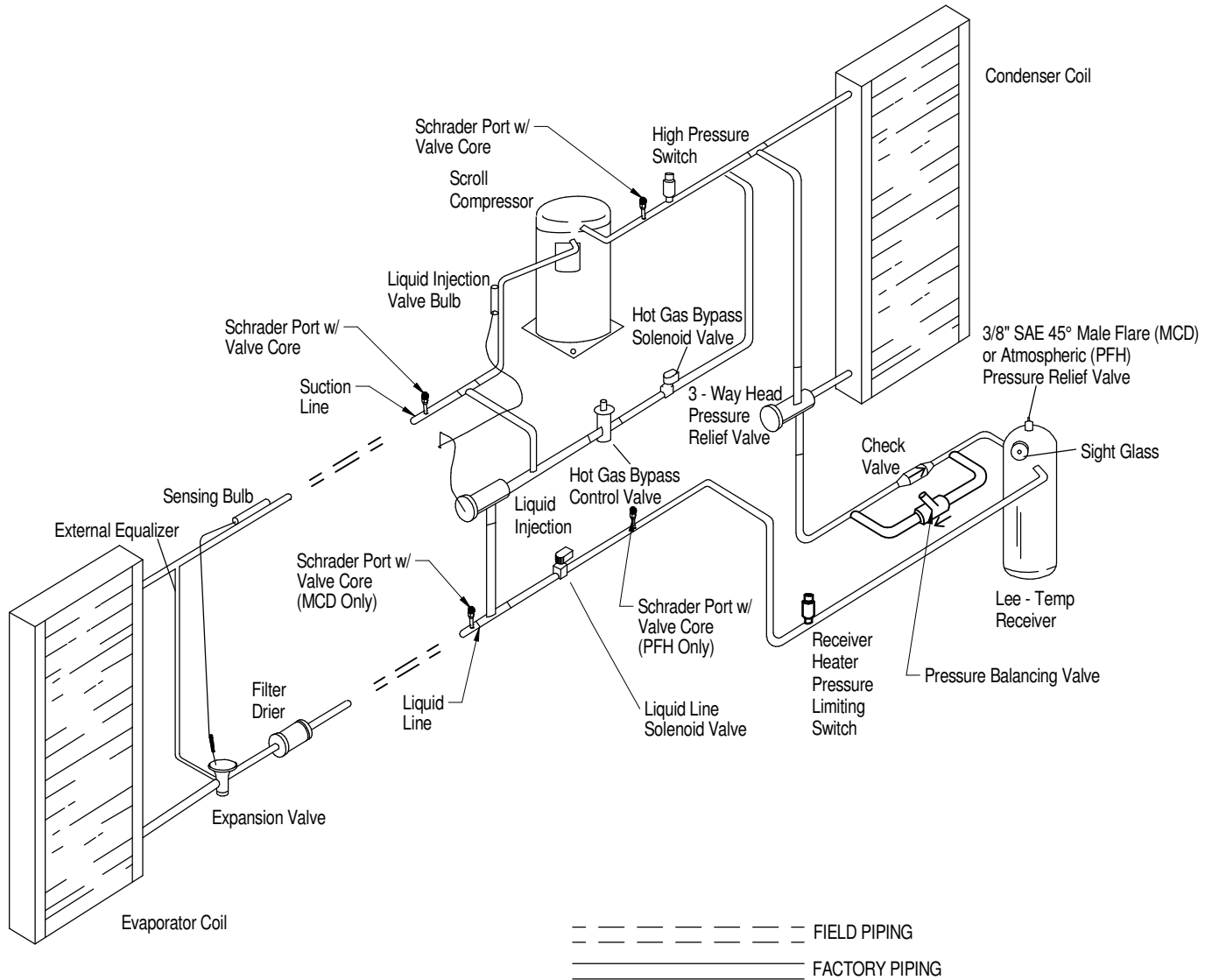

GENERAL ARRANGEMENT DIAGRAM SPLIT SYSTEMS WATER/GLYCOL COOLED

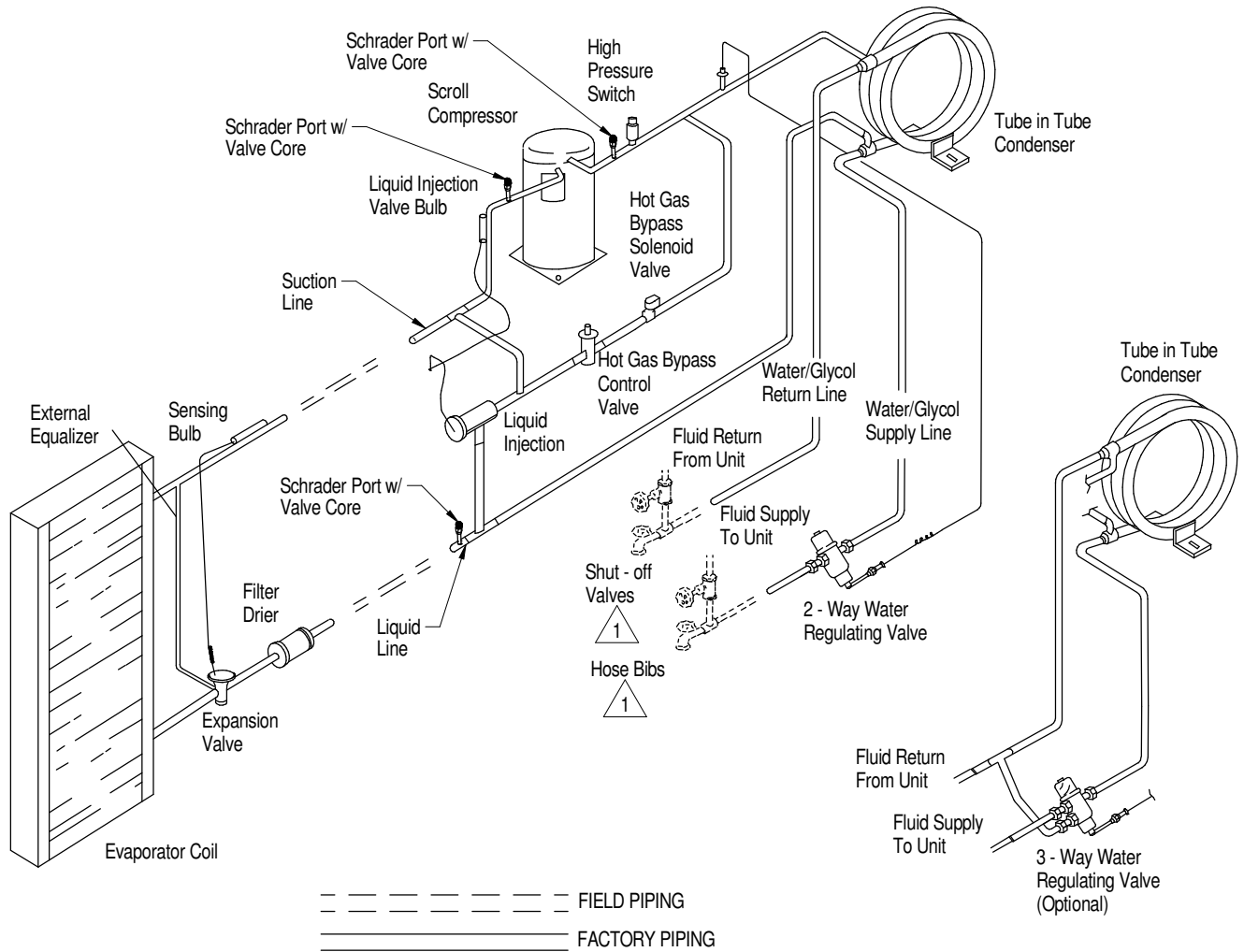

Notes:

1. Components are not supplied by Liebert but are required for proper circuit operation and maintenance.

GENERAL ARRANGEMENT DIAGRAM CLOSE-COUPLED WATER/GLYCOL & CHILLED WATER MODELS

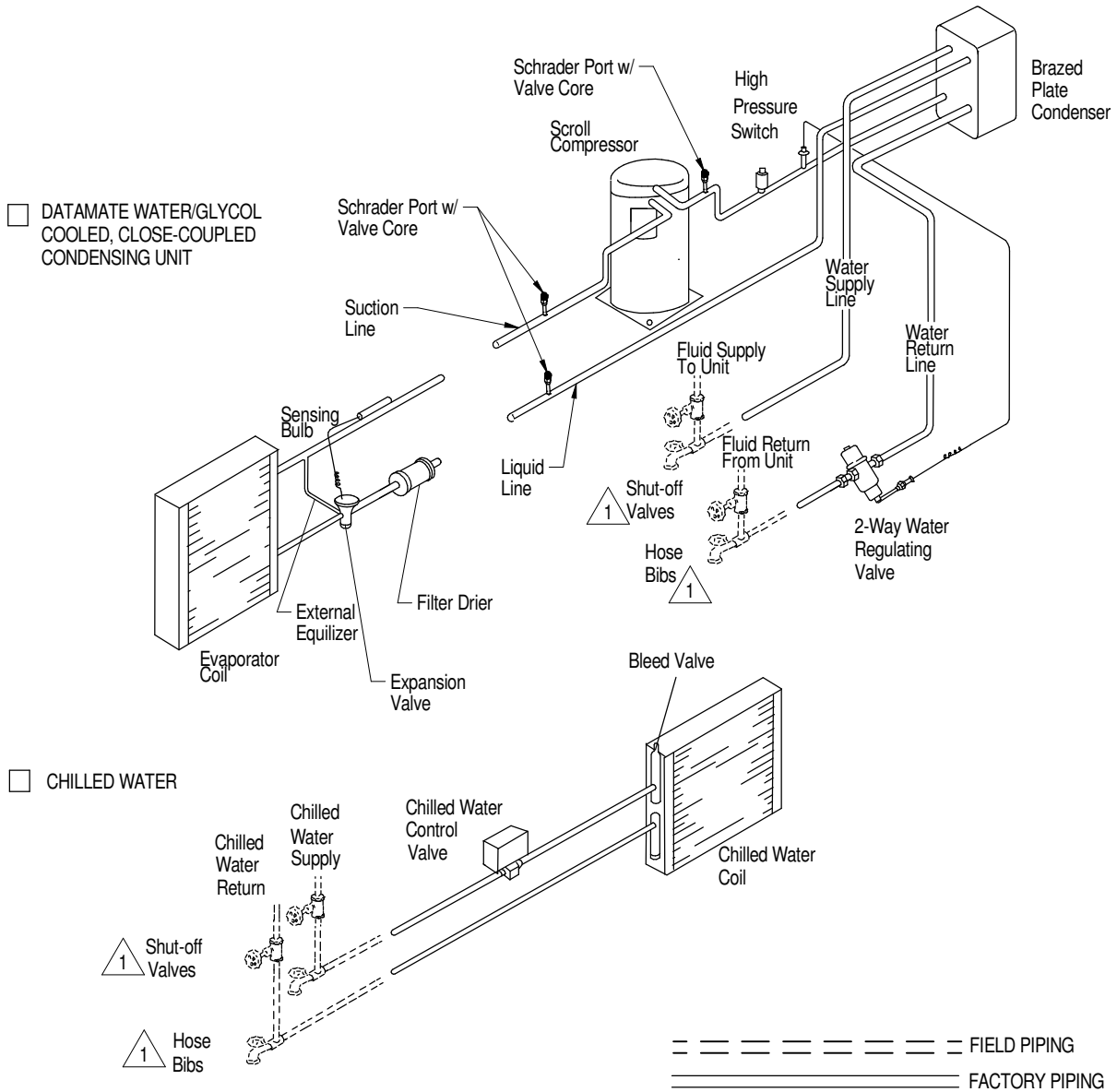

Notes:

1. Components are not supplied by Liebert, but are required for proper circuit operation and maintenance.

PRIMARY CONNECTION LOCATIONS FAN/COIL & CHILLED WATER MODULES

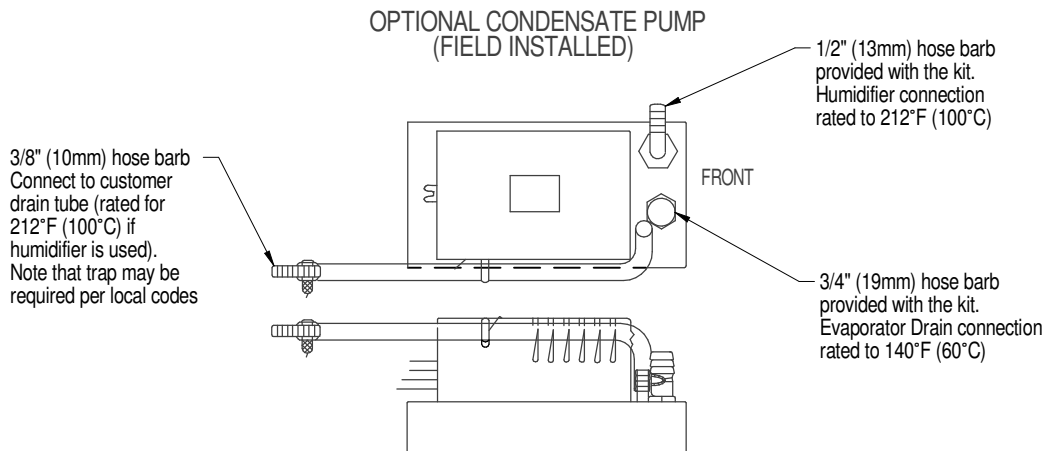
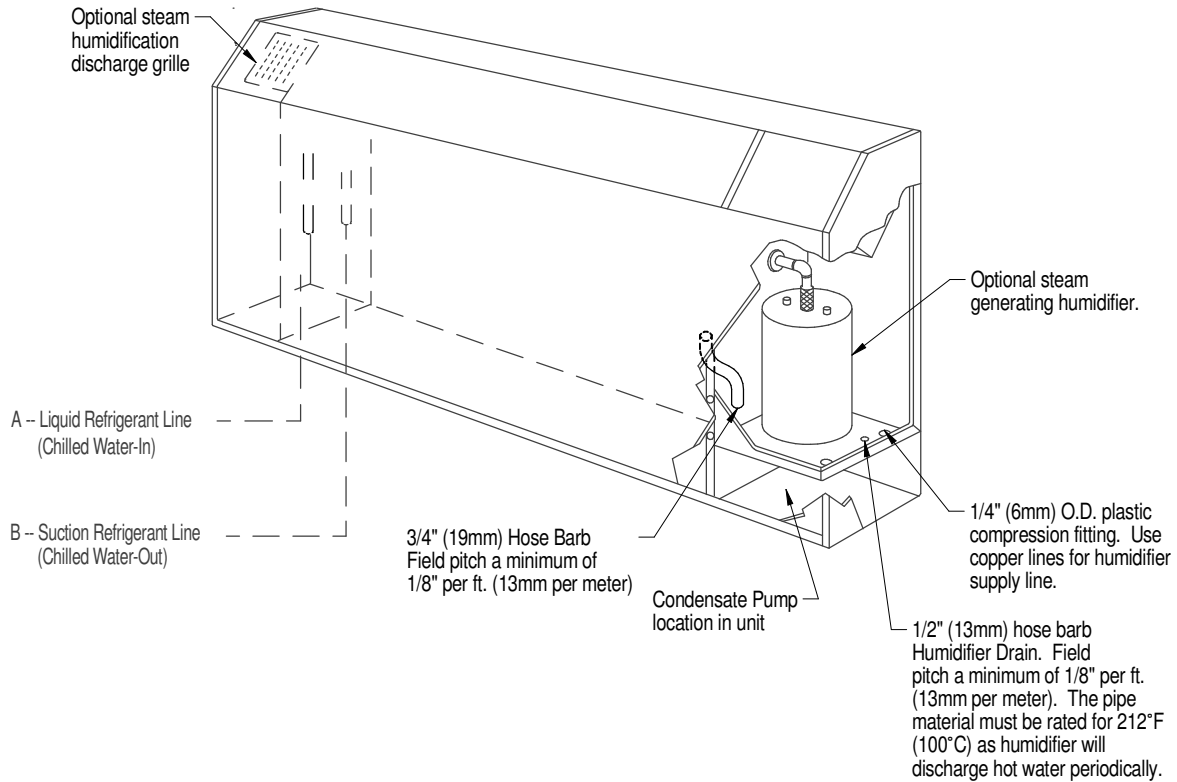

UNIT PIPING OUTLET CONNECTION SIZES O.D. CU		
MODEL NUMBER	LIQUID LINE A	SUCTION LINE B
DME020E	3/8"	5/8"
DME027E		7/8"
DME037E		
	WATER INLET	WATER OUTLET
DME044C	7/8"	7/8"

LIEBERT DATAMATE

PRIMARY CONNECTION LOCATIONS WATER/GLYCOL CONDENSING UNIT

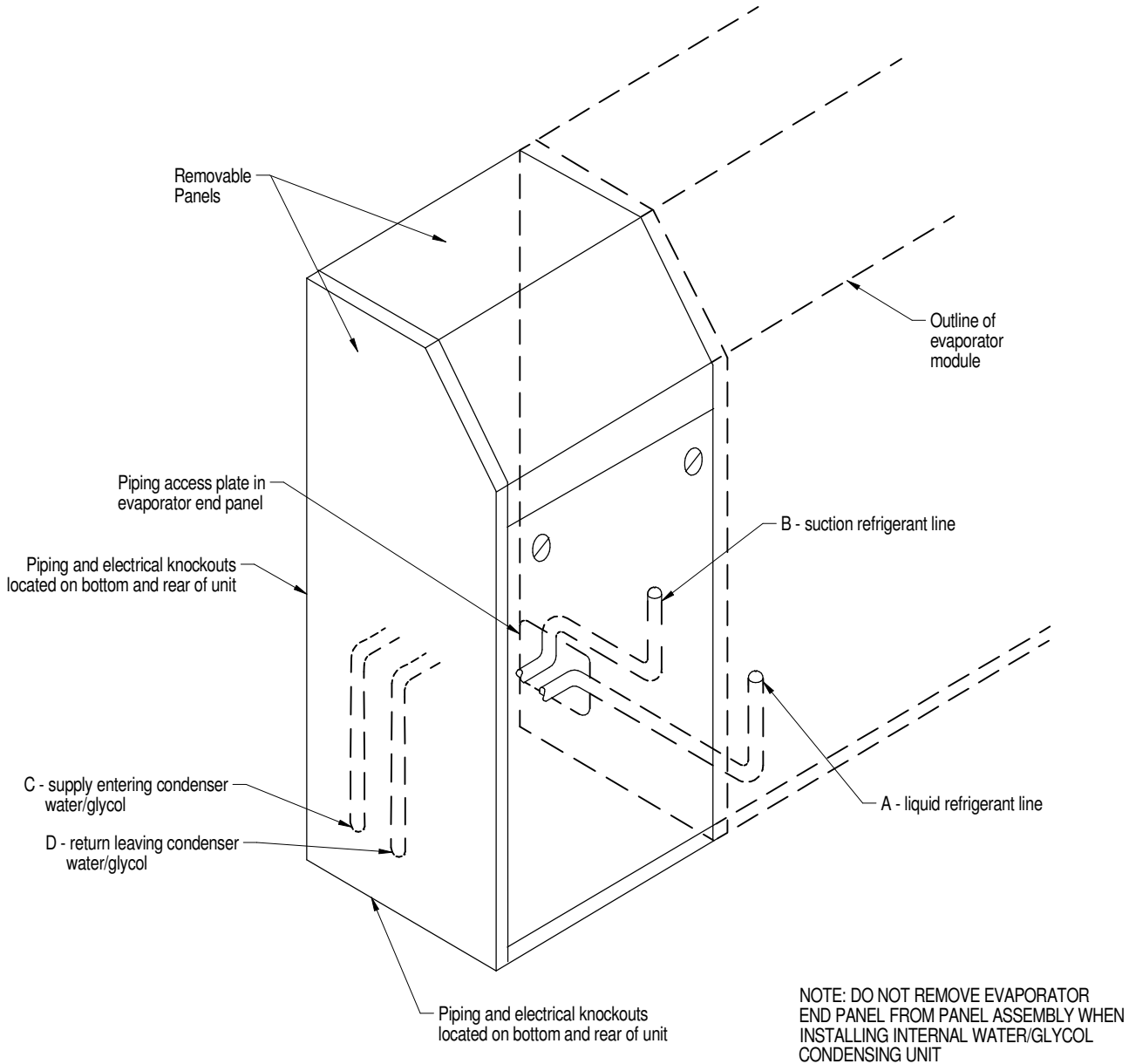

MODEL NUMBER	UNIT REFRIGERANT CONNECTION SIZES O.D. CU		WATER/GLYCOL PIPING CONNECTION SIZES O.D. CU	
	LIQUID LINE	SUCTION LINE	SUPPLY	RETURN
	A	B	C	D
DMC022WG	3/8"	5/8"	5/8"	5/8"
DMC029WG		7/8"	7/8"	7/8"
DMC040WG				

LIEBERT DATAMATE

ELECTRICAL FIELD CONNECTIONS FAN/COIL & CHILLED WATER SYSTEMS

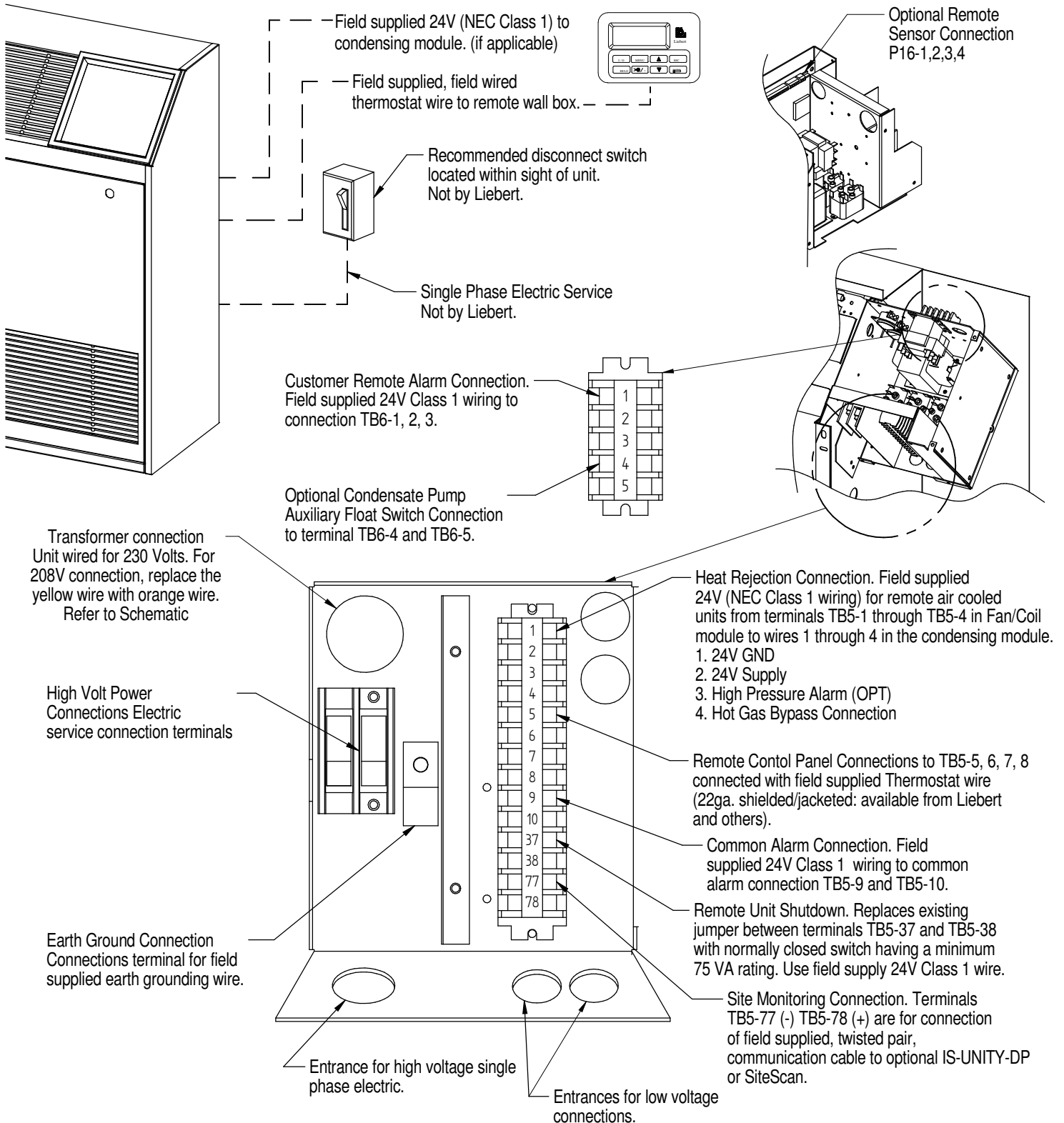

NOTE: Refer to specification sheet for full load amp. and wire size amp. ratings.

ELECTRICAL FIELD CONNECTIONS WATER/GLYCOL COOLED MODELS

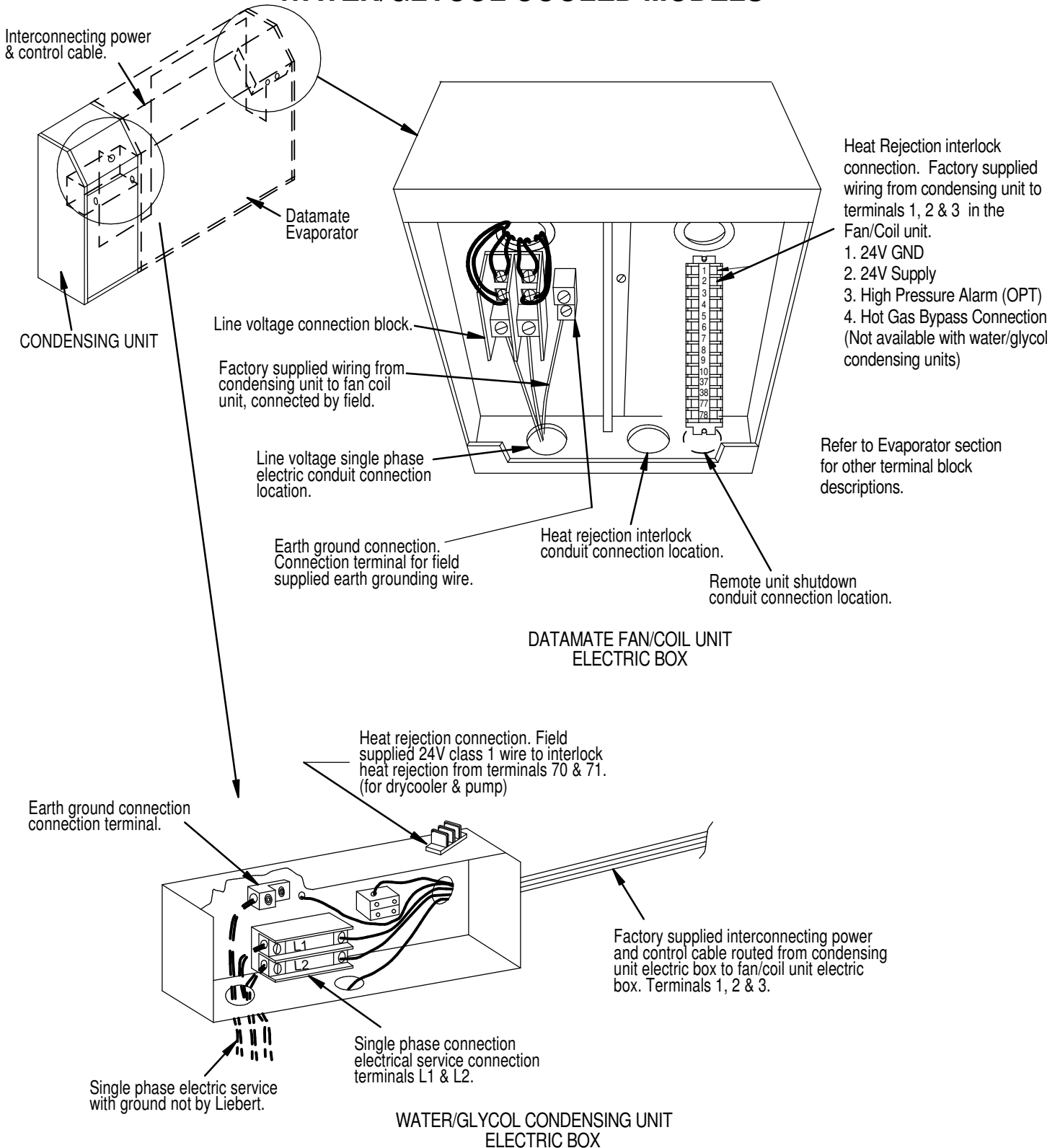

NOTE: Refer to specification sheet for full load amp. and wire size amp. ratings.

LIEBERT DATAMATE

GENERAL ARRANGEMENT & DIMENSIONAL DATA WALL MOUNTED IS-UNITY-DP CARD FOR BMS CONNECTIVITY

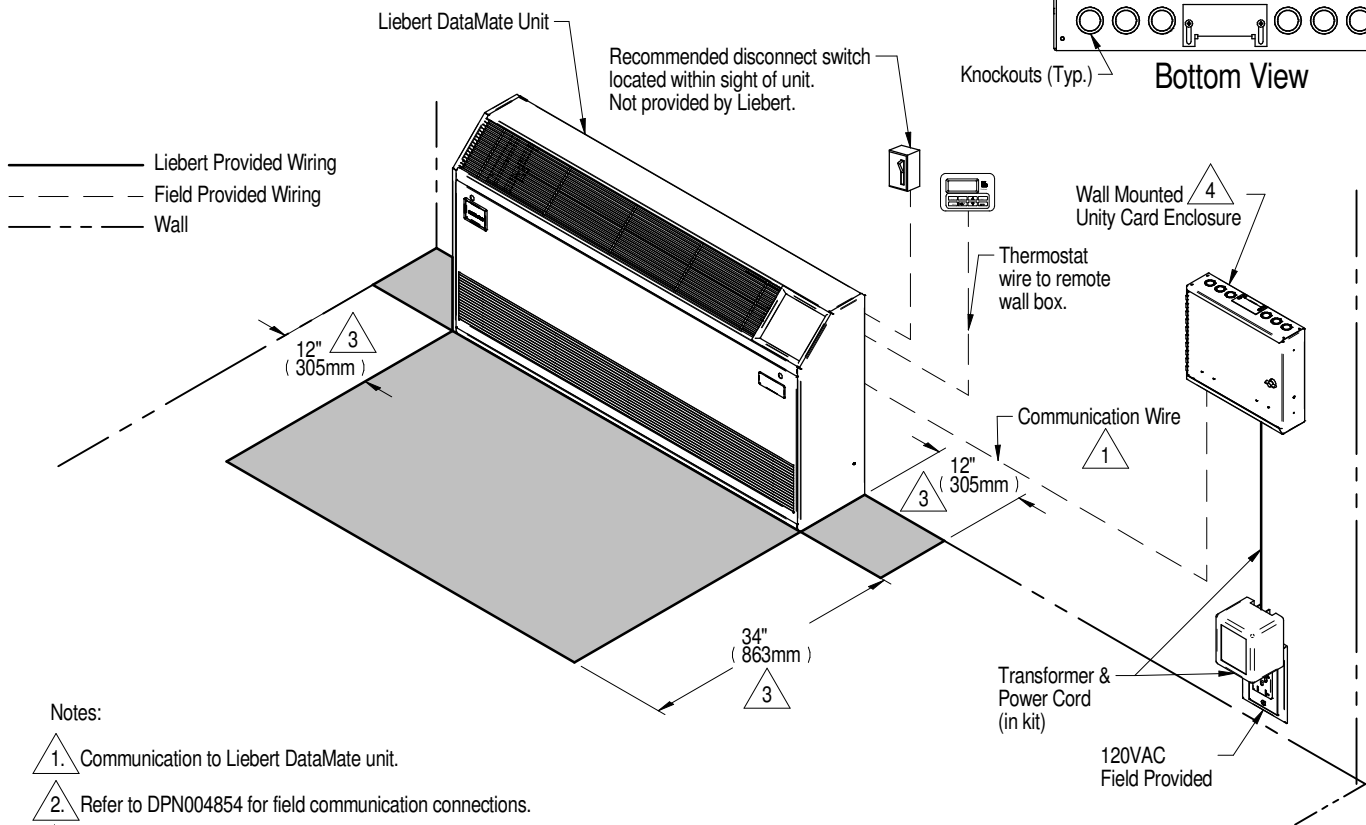
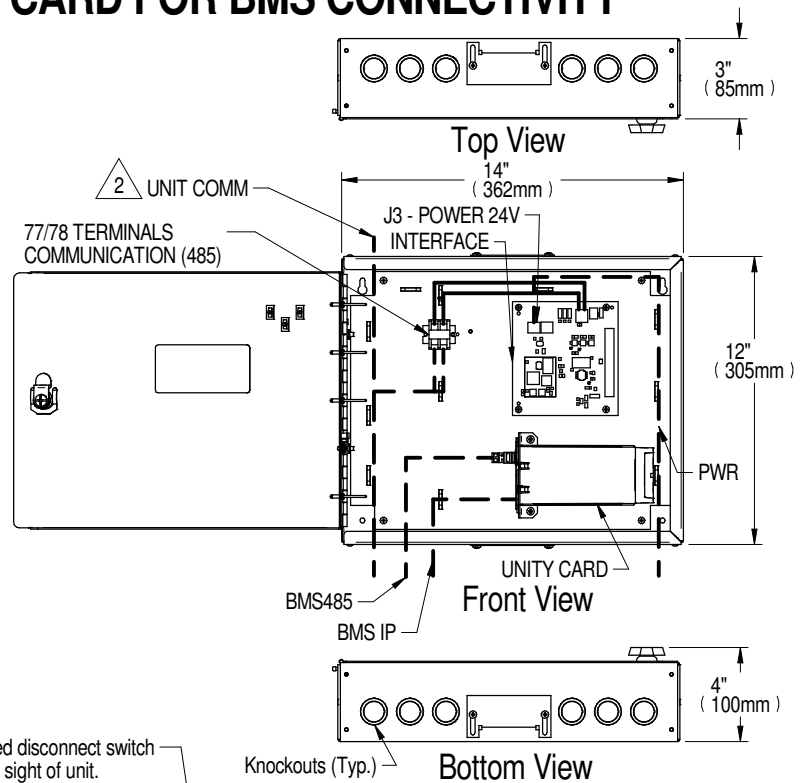

Notes:

- 1. Communication to Liebert DataMate unit.
- 2. Refer to DPN004854 for field communication connections.
- 3. Shaded areas indicate a recommended minimum clearance be provided for component access.
- 4. Locate the Unity Card Enclosure within 6' (1.8m) (length of power cord) of a 120V wall receptacle.

BMS COMMUNICATION CONNECTION OPTIONS LIEBERT MINI-MATE2 & DATAMATE

BMS IP/485
(1 Cooling Unit only)

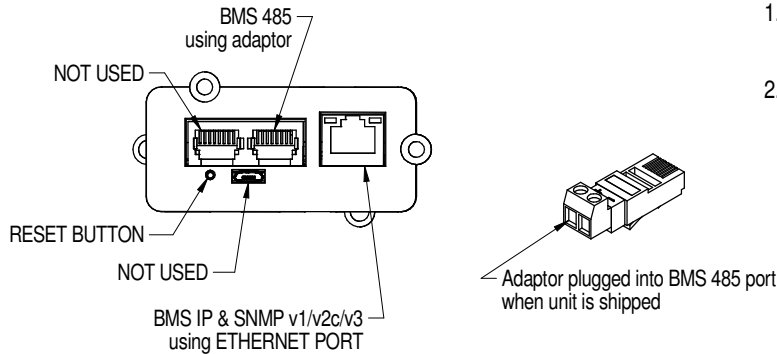

1. Building Management System (BMS) Protocols
 - *BACNet over IP/485
 - *Modbus over IP/485
2. Communication wiring is field supplied
 - IP - use CAT5e cable or greater
 - 485 - use EIA 485 rated, shielded, twisted pair cable, 22-18AWG.
 - Must be rated to meet local codes and conditions.

UNIT TO INTERFACE BOARD CONNECTIONS

	UNIT		UNIT MOUNTED KITS*		WALL MOUNTED KITS**	
	TERMINAL/PLUG	POSITION	TERMINAL/PLUG	POSITION	TERMINAL/PLUG	POSITION
Liebert Mini-Mate2 1-5 Ton						
COMMUNICATION (485)	TB4	1 / 2	J2	2 / 1	77 / 78	N/A
POWER 24V	20, 21	N/A	J3	1 / 2	J3	1 / 2
Liebert Mini-Mate2 8 Ton						
COMMUNICATION (485)	77, 78	N/A	J2	2 / 1	77 / 78	N/A
POWER 24V	TB1	4 / 8	J3	1 / 2	J3	1 / 2
Liebert DataMate						
COMMUNICATION (485)	TB5	77 / 78	N/A	N/A	77 / 78	N/A
POWER 24V	N/A	N/A	N/A	N/A	J3	1 / 2

Notes

Terminals are presented in order of connection. For example, TB4-1 connects to J2-2.

* Unit mounted kits are provided with Unit Comm & power wire harnesses; BMS Comm are field provided.

** Wall mounted kits are provided with power wire harness and 120 Volt wall outlet transformer. Unit Comm & BMS Comm are field provided.

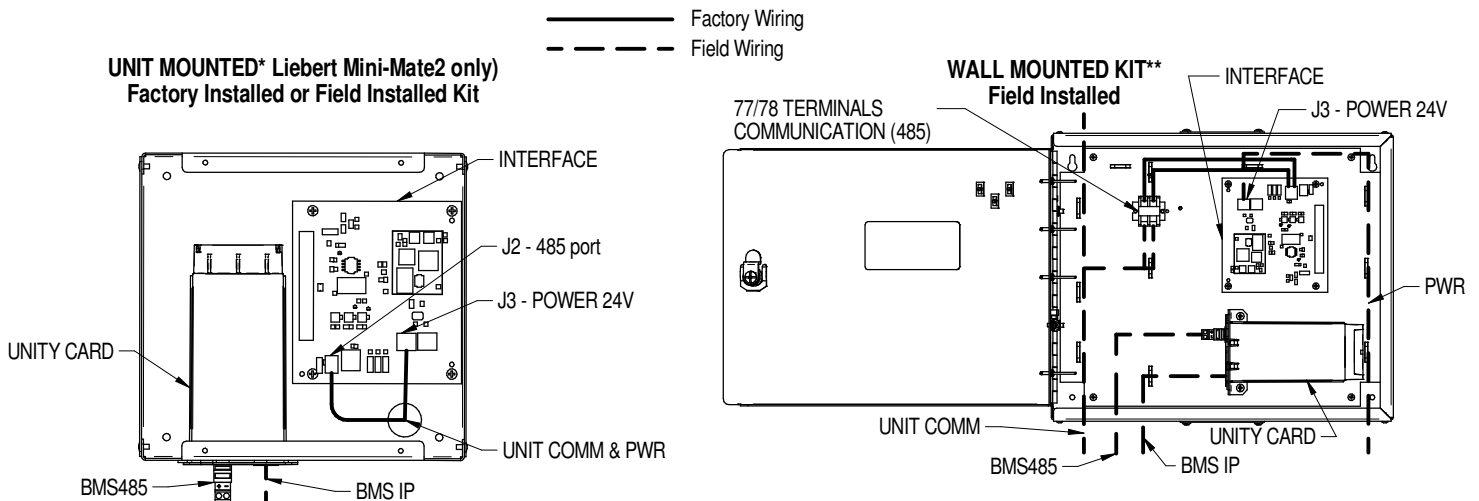

ELECTRICAL FIELD CONNECTIONS 2 & 3 TON AIR COOLED INDOOR CONDENSING MODULE

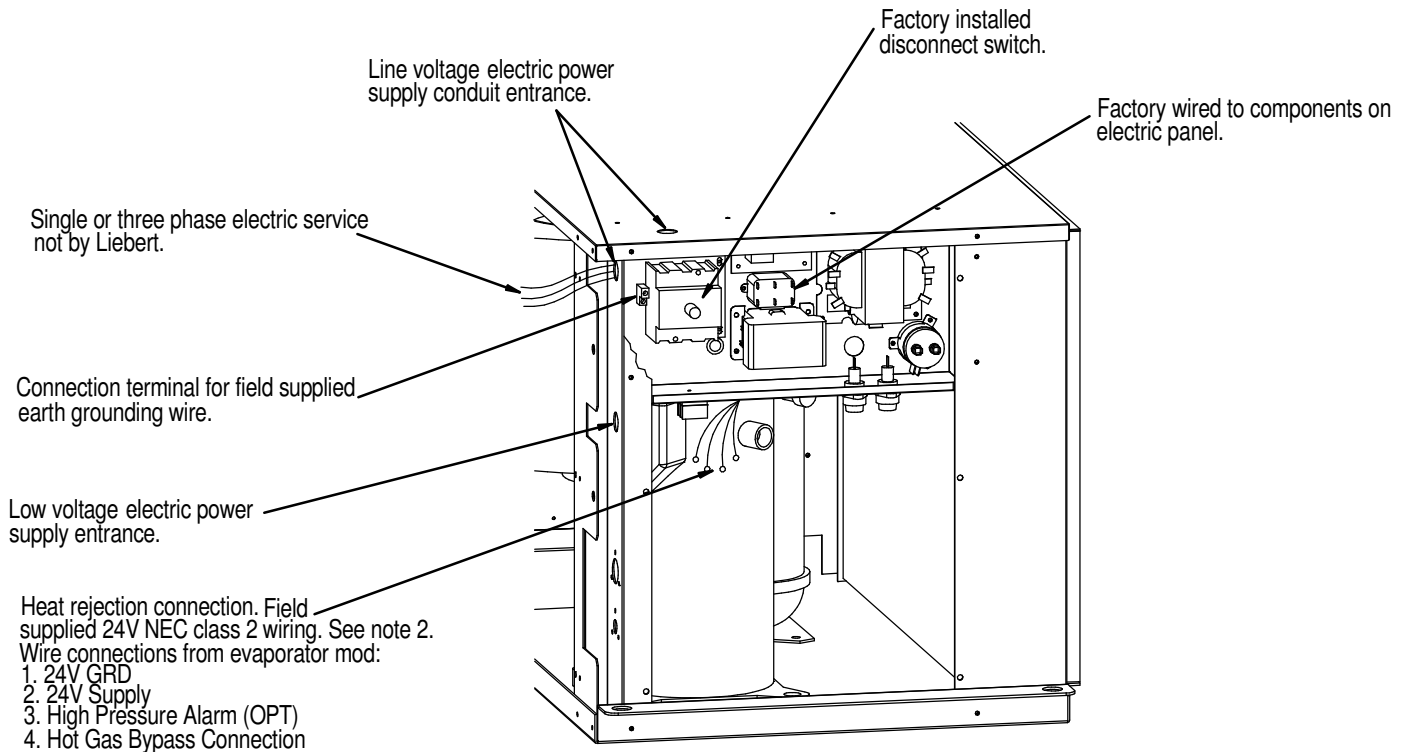
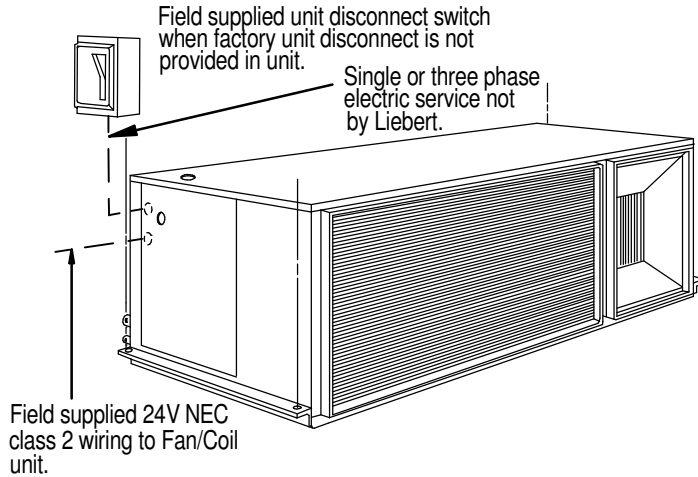

Left End View

NOTES:

1. Refer to specification sheet for full load amp and wire size amp. ratings.
2. Control voltage wiring must be a minimum of 16GA (1.3mm) for up to 75'(23m) or not to exceed 1 volt drop in control line.

ELECTRICAL FIELD CONNECTIONS

2 & 3 TON WATER/GLYCOL COOLED INDOOR CONDENSING MODULE

Single or three phase electric service not by Liebert



Field supplied unit disconnect switch when factory unit disconnect is not provided in unit.

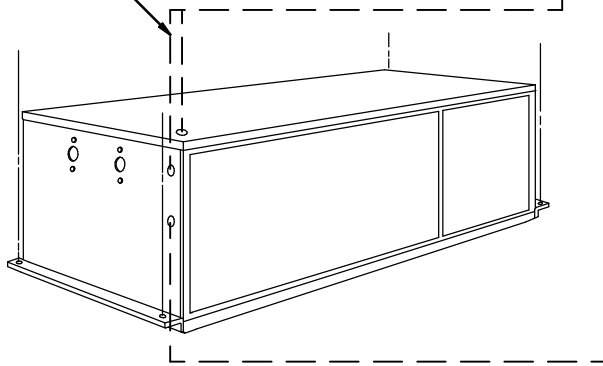

- Field supplied 24V NEC class 1 wiring to Fan/Coil unit.
- Field supplied 24V NEC class 1 wiring to Drycooler (Glycol cooled units only).

Earth ground connection.
Connection terminal for field supplied earth grounding wire.

Line voltage electric power supply entrance.

Factory wired to components on electric panel.

Optional factory installed disconnect switch.

Low voltage electric power supply entrance.

Remote Drycooler connection.
Terminals 70 & 71 supplied for connection to remote Drycooler, use field supplied 24V NEC class 1 wiring (Glycol cooled units only).

Heat Rejection Connection.
Field supplied 24V NEC class 2 wiring.
See note 2.
Wire connections from evaporator mod:
1. 24V GND
2. 24V Supply
3. High Pressure Alarm (OPT)
4. Hot Gas Bypass Connection

NOTES:

1. Refer to specification sheet for full load amp and wire size amp ratings.
2. Control voltage wiring must be a minimum of 16GA (1.3mm) for up to 75' (23m) or not to exceed 1 volt drop in control line.





Vertiv.com | Vertiv Headquarters, 1050 Dearborn Drive, Columbus, OH, 43085, USA

© 2019 Vertiv Group Corp. All rights reserved. Vertiv and the Vertiv logo are trademarks or registered trademarks of Vertiv Group Corp. All other names and logos referred to are trade names, trademarks or registered trademarks of their respective owners. While every precaution has been taken to ensure accuracy and completeness herein, Vertiv Group Corp. assumes no responsibility, and disclaims all liability, for damages resulting from use of this information or for any errors or omissions. Specifications are subject to change without notice.

SL-11040_REV8_02_20