

Canon

MULTIMEDIA PROJECTOR

WUX4000

User's Manual/ Installation Manual



AISYS
Aspectual Illumination
System

HDMI™
HIGH DEFINITION MULTIMEDIA INTERFACE

PJLink™

Table of Contents

Safety Instructions

Before Use

Projecting an Image

Useful Functions Available
During a Presentation

Setting Functions from Menus

Installation

Connecting to a Network

Maintenance

Appendix

Index

Operation

Installation and Maintenance

Appendix

ENG

How to Use This Manual

Thank you for purchasing a Canon projector.

The WUX4000 Multimedia Projector (hereinafter referred to as “the projector”) is a high-performance projector that is capable of projecting a high-resolution computer screen and high-quality digital image on a large screen.

User’s Manual (Operation)/Installation Manual (Installation and Maintenance) (This Manual)

This manual combines the user’s manual and the installation manual for the WUX4000 Multimedia Projector. The user’s manual provides information on how to use the projector. This manual describes how to install the projector as well as perform maintenance. Regarding installation of the projector, make sure that installation is performed by a qualified technician or Canon dealer. Read this manual thoroughly to make the most of your projector and ensure safety.

Symbols of Button Operations

The projector can be operated using the buttons on the remote control or on the side of the projector. The remote control allows you to operate all functions of the projector. In this document, the button’s operations are shown as below.

Operation of buttons on side of projector

Remote control button operation

Adjusting the Image Size

The size of the projected image can be adjusted by remote control or the LENS button on the projector. Change the projector installation position if your de adjust it with the zoom function. (P123)

Press either the ZOOM button on the remote control

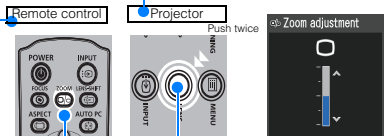

Indicate the buttons to be pressed

Symbols Used in This Manual

Meanings of the symbols used in this manual are as follows.

⚠ A precaution about operation or restriction is given here.

COPYRIGHT NOTICE

Please note that enlarging or reducing the size of an image for commercial purposes or public presentation may infringe on the legally protected copyright or the copyright holder of the original material.

About Trademarks

- Microsoft, Windows, Windows Vista and Internet Explorer are registered trademarks or trademarks of Microsoft Corporation in the United States and/or other countries.
- Macintosh and Mac are trademarks of Apple Computer, Inc., registered in the United States and/or other countries.
- HDMI, HDMI logo, and High Definition Multimedia Interface are trademarks or registered trademarks of HDMI Licensing, LLC.
- PjLink is a registered trademark, or an application has been submitted for trademark, in Japan, the United States and/or other countries or regions.

Quick Reference Guide

This Quick Reference Guide will help you find functions that make full use of the projector and are useful for producing an attractive presentation, etc.

Connecting the Projector

Connecting to the Computer (P37 - P39)
Connecting to AV Equipment (P40 - P42)

Projecting an Image

Starting Projection (P43 - P45)
Selecting an Input Signal (P46 - P47)

Adjusting the Image

Adjusting the Image Size and Focus (P56, P57)
Adjusting Keystone Distortion (P59)
Adjusting Aspect Ratio (P50 - P55)
Eliminating Flickers from Computer Screen and Adjusting Positional Shift (P77, P78)

Adjusting Colors and Image Quality

Projecting an Image on a Greenboard (P82)
Selecting an Image Mode Suitable for the Projecting Image (P86)
Making Fine Color Adjustments (P90)
Removing Noise (P92)

Producing a Presentation

Temporarily Blacking Out an Image (P66)
Freezing the Picture (P66)
Adjusting the Volume (P67)
Muting the Sound (P67)
Zooming an Image (P68)
Showing the Elapsed Time (P69)

Changing the Remote Control Channel (P98)

Resetting Projector Setting

Resetting Password (P101)
Initializing the Network Setting (P139)
Resetting to the Default Setting (P107)

Miscellaneous Functions

Reducing the Lamp Brightness (P95)
Using the Power Saving Mode (P96)
Turning on the Projector by Connecting the Power Cord (P96)
Disabling the Beep During Operation (P97)
Disabling Buttons (P97)
Hiding Guide Messages (P99)
Setting a Password (P101)

Table of Contents

How to Use This Manual.....	2
Quick Reference Guide.....	3
Safety Instructions.....	10
Safety Precautions	11
CAUTION ON HANGING FROM THE CEILING	11
■ READ AND KEEP THIS OWNER'S MANUAL FOR LATER USE	12
AC Power Cord Requirement.....	14
Federal Communication Commission Notice	15
Canadian Radio Interference Regulations	15
Precautions for Use.....	16
Precautions for Installation.....	17
Precautions on the lamp.....	19
Precautions for the batteries of the remote control	20
Before Use	23
Supplied Accessories.....	24
■ Installing Remote Control Batteries.....	24
Preparing the Remote Control	25
■ Remote Control Operating Range	25
Part Names	26
Main Unit of Projector.....	26
■ Front Side.....	26
■ Rear Side	26
■ Bottom Side.....	27
Remote Control	28
Side Control.....	30
■ LED Indicator Displays	31
Input Terminal	32
Operation	33
Projecting an Image	35
Steps for Connecting the Projector and Projecting an Image	36
Connecting the Projector	37
Connecting the Projector to a Computer	37
■ Connecting to RGB Monitor Output Terminal (Analog Connection).....	37
■ Connecting to DVI Monitor Output Terminal (Digital Connection).....	38
■ HDMI cable (Input signal type: [HDMI] – P46).....	39
■ Outputting Audio to Speakers.....	39
Connecting to AV Equipment.....	40
■ Connecting to Digital Video Output Terminal (Digital Connection)	40
■ Connecting to Analog Video Output Terminal (Analog Connection)	41
■ Outputting Audio to Speakers.....	42

Starting Projection	43
■ When the Language Selection Screen Appears	44
■ When the Password Input Screen Appears	44
■ When "No signal" Appears	44
■ When Notebook Computer Screen Does Not Appear	45
■ Adjusting Image	45
Changing Notebook Computer Screen Output	45
■ Turning on External Monitor Output	45
Selecting an Input Signal (INPUT)	46
■ Types of Input Signals	46
■ Selecting an Input Signal	47
Adjusting the Image	48
Setting the Display Resolution of the Computer	48
■ Windows 7	48
■ Windows Vista	48
■ Windows XP	48
■ Mac OS X	49
AUTO PC	49
■ Performing the Auto PC Function	49
Selecting Screen Aspect and Aspect	50
■ Selecting Screen Aspect	50
■ Selecting Aspect Ratio	54
Adjusting the Image Size	56
Adjusting the Focus	57
Adjusting the Image Position	58
■ Resetting the Position	59
Adjusting Keystone Distortion	59
■ Resetting the Keystone Adjustment	61
Selecting an Image Mode	62
■ Image Modes	62
■ How to Select an Image Mode	63
Turning Off the Projector	64
Useful Functions Available During a Presentation	65
Useful Functions Available During a Presentation	66
Temporarily Blacking Out an Image	66
Freezing the Picture	66
Adjusting the Volume	67
Muting the Sound	67
Zooming an Image	68
Showing the Elapsed Time	69
Setting Functions from Menus	71
How to Use Menus	72
■ Menu Configuration	72
■ Basic Operation of Menu	73

Table of Contents

Setting Display Status	75
Selecting an Image Projection Mode.....	75
Selecting an Input Signal Type (Analog PC).....	76
Selecting an Input Signal Type (Component).....	76
Adjust Input Signal (Analog PC) Total dots.....	77
Adjust Input Signal (Analog PC) Tracking.....	77
Adjust Input Signal (Analog PC) Horizontal position.....	78
Adjust Input Signal (Analog PC) Vertical position.....	78
Adjust Input Signal (Analog PC) Horizontal pixels.....	79
Adjust Input Signal (Analog PC) Vertical pixels.....	79
Selecting HDMI Input Level.....	80
HDMI color format.....	80
Select HDMI Over Scan.....	81
Performing Progressive Processing.....	81
Selecting a Menu Position.....	82
Correcting the Screen Color.....	82
Reversing Projection.....	83
No Signal Screen.....	84
Screen When Blank.....	84
Selecting a Logo at Startup.....	85
Selecting Aspect Ratio of Screen.....	85
Selecting an Image Quality	86
Image adjustment.....	86
Saving the Desired Image Quality.....	87
Adjusting the Brightness.....	88
Adjusting the Contrast.....	88
Adjusting the Sharpness.....	89
Making a Gamma Correction.....	89
Adjusting Color.....	90
Correcting the Image According to the Ambient Light.....	91
Noise reduction.....	92
Dynamic gamma.....	92
Memory Color Correction.....	93
6-axis color adjust.....	93
Detailed Gamma Correction.....	94
Reducing the Lamp Brightness.....	95
Resetting the Image Settings.....	95
Setting Various Functions.....	96
Selecting the Power Management Mode.....	96
Skip the POWER Button Operation.....	96
Enabling/Disabling the Beep.....	97
Prohibiting Operation of the Projector.....	97

Setting up the Remote Control Channel	98
Selecting a Display Language	99
Showing/Hiding the Guide Screen	99
Showing/Hiding the Input Status	100
Selecting the HDMI Input	100
Setting a Password	101
Registering a Password	102
Prohibiting Operation of the Lens	102
Lens Shift Reset	103
Extending the Menu Display Time	103
Showing/Hiding the High Temperature Warning Icon	104
Reducing Flickering	104
Resetting the Lamp Counter	105
■ About the Display of the Lamp Counter	106
Resetting to the Default Setting	107
Checking Projector Information	108

Installation and Maintenance 109

Installation	111
Installation Precautions	112
Precautions When Carrying the Projector	112
Installation Precautions	112
Precautions When Carrying and Transporting the Projector	112
■ When using mounted on the ceiling	114
■ Install facing in the correct direction	114
Installation Procedure	115
Selecting the Projection Method and Installation Location	116
■ Ceiling Mounting or Rear Projection	116
■ Inclining the Projector Upwards When Installed on a Flat Surface	116
Installing/Removing the Lens Unit	117
■ Installing the Lens Unit	117
■ Removing the Lens Unit	121
Setting Up the Projector	122
■ Positioning the Projector in Front of the Screen	122
■ Relationship Between Image Size and Projecting Distance	122
■ Lens Shift Function	124
Connecting to AV Equipment	126
■ Connectable Equipment and Input Terminals	126
■ Connection Terminal and Connection Cable	127

Table of Contents

Connecting to a Network	129
Preparing the Remote Control	130
Connection Methods	130
Setting an IP Address.....	131
■ Windows 7.....	131
■ Windows Vista.....	132
■ Windows XP	133
■ Mac OS X.....	134
■ Resetting the IP Address Setting of the Computer	134
Network Settings on the Projector	135
Locking the Network Settings.....	135
Turning On/Off the Network Function.....	136
Setting a Network Password	136
Registering a Network Password	137
Turning On/Off the PjLink Function	137
Turning On/Off DHCP Function.....	138
TCP/IP Setting.....	139
Initializing Network Settings	139
Configuring the Network From the Computer	140
■ Displaying and Configuring the Network Configuration Screen	140
■ Resetting to Factory Defaults.....	143
■ Setting Errors	143
Setting Up the Network	145
■ Setting Basic Information [Network]	145
■ Setting Up Email [Mail]	146
■ Mail Authentication Settings [Mail auth].....	147
■ Sending a Test Mail [Send test mail]	148
■ SNMP Settings [SNMP].....	148
■ Setting Projector Information [Projector info.]	149
■ Setting PjLink [PjLink]	150
Controlling the Projector from a Computer	151
Error Mail	153
Maintenance	155
Cleaning the Projector	156
Cleaning and Replacing the Air Filter	157
Replacing the Air Filter.....	157
Cleaning the Air Filter.....	158
Replacing the Lamp	159
Replacement Lamp	160
Replacing the Lamp	160

Appendix 163

Appendix 165

Troubleshooting 166

 LED Indicator Meanings 166

 Symptoms and Solutions 167

 ■ You Cannot Turn on the Projector 167

 ■ You Cannot Project an Image from the Projector 167

 ■ You Cannot Hear Sound 168

 ■ The Projected Image Is Blurred 169

 ■ You Cannot Project an Image Appropriately 169

 ■ The Projector Power Turns Off 169

 ■ You Cannot Operate the Remote Control 170

Relationship between Aspect and Screen Aspect 171

Supported Signal Types 173

Product Specifications 174

 ■ Projector 174

 ■ Remote control 174

 ■ Specification of Each Lens Unit (Option) 175

 ■ External View 176

 ■ ANALOG PC/COMPONENT IN Terminal 176

 ■ Service Port (CONTROL) 177

Index 180

Menu Configuration 183

Safety Instructions

Before installing and operating the projector, read this manual thoroughly.

This projector provides many convenient features and functions. Operating the projector properly enables you to manage those features and maintain it in good condition for many years to come.

Improper operation may result in not only shortening the product life, but also malfunctions, fire hazards, or other accidents.

If your projector does not seem to be operating properly, read this manual again, check operations and cable connections, and try the solutions in the “Troubleshooting” section in the back of this manual. If the problem still persists, contact the dealer where you purchased the projector or the service center.



CAUTION

**RISK OF ELECTRIC SHOCK
DO NOT OPEN**



CAUTION: TO REDUCE THE RISK OF ELECTRIC SHOCK, DO NOT REMOVE COVER (OR BACK). NO USER-SERVICEABLE PARTS INSIDE EXCEPT LAMP REPLACEMENT. REFER SERVICING TO QUALIFIED SERVICE PERSONNEL.



THIS SYMBOL INDICATES THAT DANGEROUS VOLTAGE CONSTITUTING A RISK OF ELECTRIC SHOCK IS PRESENT WITHIN THIS UNIT.



THIS SYMBOL INDICATES THAT THERE ARE IMPORTANT OPERATING AND MAINTENANCE INSTRUCTIONS FOR THIS UNIT IN THE OWNER'S MANUAL.

CAUTION

Not for use in a computer room as defined in the Standard for the Protection of Electronic Computer/Data Processing Equipment, ANSI/NFPA 75.

Safety Precautions

WARNING:

- **THIS APPARATUS MUST BE GROUNDED.**
- **TO REDUCE THE RISK OF FIRE OR ELECTRIC SHOCK, DO NOT EXPOSE THIS APPLIANCE TO RAIN OR MOISTURE.**
- This projector produces intense light from the projection lens. Do not stare directly into the lens, otherwise eye damage could result. Be especially careful that children do not stare directly into the beam.
- Install the projector in a proper position. Otherwise it may result in a fire hazard.
- Allowing the proper amount of space on the top, sides, and rear of the projector cabinet is critical for proper air circulation and cooling of the unit. The diagrams shown here indicate the minimum space required. If the projector is to be built into a compartment or similarly enclosed, these minimum distances must be maintained.

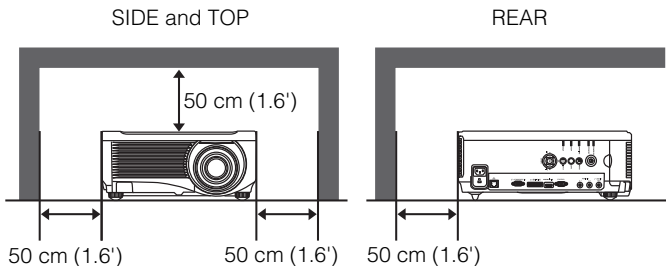

- Do not cover the ventilation slots on the projector. Heat build-up can reduce the service life of your projector, and can also be dangerous.
- If the projector is unused for an extended time, unplug the projector from the power outlet.
- Do not project the same image for a long time.

An afterimage may remain on the LCD panels due to the characteristics of the panels of the projector.

CAUTION ON HANGING FROM THE CEILING

When hanging the projector from the ceiling, clean the air intake vents and top of the projector periodically with a vacuum cleaner. If you leave the projector unclean for a long time, the cooling fans can be clogged with dust, and it may cause a breakdown or a disaster.

DO NOT SET THE PROJECTOR IN GREASY, WET, OR SMOKY CONDITIONS SUCH AS IN A KITCHEN TO PREVENT A BREAKDOWN OR A DISASTER. IF THE PROJECTOR COMES IN CONTACT WITH OIL OR CHEMICALS, IT MAY BECOME DETERIORATED.

Safety Instructions

■ READ AND KEEP THIS OWNER'S MANUAL FOR LATER USE.

All the safety and operating instructions should be read before beginning to operate the product.

Read all of the instructions given here and retain them for later use. Unplug this projector from the AC power supply before cleaning. Do not use liquid or aerosol cleaners on the projector. Use a damp cloth for cleaning.

Follow all warnings and instructions marked on the projector.

For added protection of the projector during a lightning storm, or when it is left unattended or unused for long periods of time, unplug it from the wall outlet. This will prevent damage due to lightning and power surges.

Do not expose this unit to rain or use near water... for example, in a wet basement, near a swimming pool, etc...

Do not use attachments not recommended by the manufacturer as they may result in hazards.

Do not place this projector on an unstable cart, stand, or table. The projector may fall, causing serious injury to a child or adult, and serious damage to the projector. Use only with a cart or stand recommended by the manufacturer, or sold with the projector. Wall or shelf mounting should be carried out in accordance with the manufacturer's directions, and should use a mounting kit approved by the manufacturers.

An appliance and cart combination should be moved with care.

Sudden stops, excessive force, and uneven surfaces may cause the appliance and cart combination to overturn.



Slots and openings in the rear and front of the cabinet are provided for ventilation, to insure reliable operation of the equipment and to protect it from overheating.

The openings should never be covered with cloth or other materials, and the bottom opening should not be blocked by placing the projector on a bed, sofa, rug, or other similar surface. This projector should never be placed near or over a radiator or heat register.

This projector should not be placed in a built-in installation such as a book case unless proper ventilation is provided.

Never push objects of any kind into this projector through cabinet slots as they may touch dangerous voltage points or short out parts that could result in a fire or electric shock. Never spill liquid of any kind onto the projector.

Do not install the projector near the ventilation duct of air-conditioning equipment.

This projector should be operated using only the type of power source indicated on the marking label. If you are not sure of the type of power supplied, consult your authorized dealer or local power company.

Do not overload wall outlets and extension cords as this can result in fire or electric shock. Do not allow anything to rest on the power cord. Do not locate this projector where the cord may be damaged by people walking on it.

Do not attempt to service this projector yourself as opening or removing covers may expose you to dangerous voltages or other hazards. Refer all servicing to qualified service personnel.

Unplug this projector from the wall outlet and refer servicing to qualified service personnel under the following conditions:

- a. When the power cord or plug is damaged or frayed.
- b. If liquid has been spilled into the projector.
- c. If the projector has been exposed to rain or water.
- d. If the projector does not operate normally after following the operating instructions. Adjust only those controls that are covered in the operating instructions as improper adjustment of other controls may result in damage and will often require extensive work by a qualified technician to restore the projector to normal operating condition.
- e. If the projector has been dropped or the cabinet has been damaged.
- f. When the projector exhibits a distinct change in performance-this indicates a need for servicing.

When replacement parts are required, be sure the service technician uses replacement parts specified by the manufacturer that have the same characteristics as the original parts. Unauthorized substitutions may result in fire, electric shock, or injury.

Upon completion of any service or repairs to this projector, ask the service technician to perform routine safety checks to determine that the projector is in safe operating condition.

AC Power Cord Requirement

The AC Power Cord supplied with this projector meets the requirements for use in the country you purchased it.

AC Power Cord for the United States and Canada:

The AC Power Cord used in the United States and Canada is listed by the Underwriters Laboratories (UL) and certified by the Canadian Standard Association (CSA).

The AC Power Cord has a grounding-type AC line plug. This is a safety feature to ensure the plug fits into the power outlet. Do not try to tamper with this safety feature. Should you be unable to insert the plug into the outlet, contact your electrician.

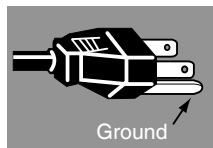

THE SOCKET-OUTLET SHOULD BE INSTALLED NEAR THE EQUIPMENT AND EASILY ACCESSIBLE.

NOTE FOR CUSTOMERS IN THE US

 LAMP(S) INSIDE THIS PRODUCT CONTAIN MERCURY AND MUST BE RECYCLED OR DISPOSED OF ACCORDING TO LOCAL, STATE OR FEDERAL LAWS.



European Union (and EEA) only.

These symbols indicate that this product is not to be disposed of with your household waste, according to the WEEE Directive (2002/96/EC), the Battery Directive (2006/66/EC) and/or your national laws implementing those Directives. If a chemical symbol is printed beneath the symbol shown above, in accordance with the Battery Directive, this indicates that a heavy metal (Hg = Mercury, Cd = Cadmium, Pb = Lead) is present in this battery or accumulator at a concentration above an applicable threshold specified in the Battery Directive. This product should be handed over to a designated collection point, e.g., on an authorized one-for-one basis when you buy a new similar product or to an authorized collection site for recycling waste electrical and electronic equipment (EEE) and batteries and accumulators. Improper handling of this type of waste could have a possible impact on the environment and human health due to potentially hazardous substances that are generally associated with EEE. Your cooperation in the correct disposal of this product will contribute to the effective usage of natural resources. For more information about the recycling of this product, please contact your local city office, waste authority, approved scheme or your household waste disposal service or visit www.canon-europe.com/environment.

(EEA: Norway, Iceland and Liechtenstein)

Federal Communication Commission Notice

Multimedia Projector, Model: WUX4000

This device complies with Part 15 of the FCC Rules. Operation is subject to the following two conditions:

- (1) This device may not cause harmful interference, and
- (2) this device must accept any interference received, including interference that may cause undesired operation.

Note: This equipment has been tested and found to comply with the limits for a Class B digital device, pursuant to Part 15 of the FCC Rules. These limits are designed to provide reasonable protection against harmful interference in a residential installation. This equipment generates, uses and can radiate radio frequency energy and, if not installed and used in accordance with the instructions, may cause harmful interference to radio communications. However, there is no guarantee that interference will not occur in a particular installation. If this equipment does cause harmful interference to radio or television reception, which can be determined by turning the equipment off and on, the user is encouraged to try to correct the interference by one or more of the following measures:

- Reorient or relocate the receiving antenna.
- Increase the separation between the equipment and receiver.
- Connect the equipment into an outlet on a circuit different from that to which the receiver is connected.
- Consult the dealer or an experienced radio/TV technician for help.

The cable with a ferrite core provided with the projector must be used with this equipment in order to comply with Class B limits in Subpart B of Part 15 of the FCC rules. Use of a shielded cable is required to comply with class B limits in Subpart B of Part 15 of FCC Rules.

Do not make any changes or modifications to the equipment unless otherwise specified in the instructions. If such changes or modifications should be made, you could be required to stop operation of the equipment.

Canon U.S.A. Inc.

One Canon Plaza, Lake Success, NY 11042-1198, U.S.A.

Tel No. (516) 328-5600

Canadian Radio Interference Regulations

This Class B digital apparatus complies with Canadian ICES-003.

Precautions for Use

As this section contains important safety-related information, be sure to read the following carefully beforehand in order to use your projector correctly and safely.

Warning

If the following situations occur, turn the power off, remove the power plug from the power outlet and contact a Canon dealer. Failure to do so could cause a fire or result in an electric shock.

- If smoke is emitted
- If an unusual smell or noise is emitted
- If a loud noise is heard and the lamp turns off
- If water or other liquid has entered the projector
- If metal or any other foreign material has entered the projector
- If the projector is knocked over or dropped and the cabinet is damaged

Warning

Pay attention to the following points for handling the power cord. Failing to pay attention to these points could cause a fire, electric shock or personal injury.

- Do not place any objects on the power cord and do not allow it to become trapped under the projector. The power cord may be damaged.
- If the power cord is covered by a carpet, you may place heavy objects on it without noticing.
- Do not excessively bend, twist, pull or make modifications to the power cord.
- Keep the power cord away from heaters and other sources of heat.
- Do not use the power cord when it is bent finely, coiled or bundled.
- Do not use a damaged power cord. If your power cord is damaged, purchase a replacement from a Canon dealer.
- Do not use any power cord other than the type that is included with this projector.
- Be sure to connect the ground wire of the power cord to ground. Failure to do so could result in an electric shock.
- Be sure to connect the ground wire before connecting the power plug to the outlet. Also when you disconnect the ground wire, be sure to unplug the power plug from the outlet beforehand.

 **Warning**

Pay attention to the following points regarding the power source, power plug and handling of the connector. Failure to do so could result in a fire, electric shock or personal injury.

- Do not use any power source with a voltage other than the voltage indicated (AC 100 – 240 V).
- Do not pull the power cord and be sure to hold the power plug or connector when removing. The cord could be damaged as a result.
- Do not insert any metal objects into the contact parts of the power plug or connector.
- Remove the power plug from the outlet before performing cleaning or maintenance of the projector.
- Do not remove the power plug or connector with wet hands.
- Insert the power plug and connector securely up to the base. Additionally, do not use a damaged power plug or an outlet that is loose.
- If using an extension cord attached to the outlet, make sure that the total electric power consumption of connected devices does not exceed the rated capacity.
- Periodically inspect the power plug and outlet and remove any dust or dirt from between the plug and the outlet.

Precautions for Installation

 **Warning**

Pay attention to the following points regarding installation and handling of the projector. Failure to do so may cause a fire, electric shock or personal injury.

- Do not use the projector in a bathroom or shower room.
- Do not use the projector in rain or snow, by the sea, or in close proximity to a body of water.
- Do not place containers containing a liquid on top of the projector.
- Do not place the projector in any location where it will be exposed to oily smoke or steam, such as a kitchen work surface or table etc.
- Do not touch the projector itself, the power cord, or the cable if lightning strikes.

Warning

Pay attention to the following points regarding installation and handling of the projector. Failure to do so may cause a fire, electric shock or personal injury.

- Do not move the projector until you have switched off the power, removed the power plug from the power outlet and unplugged any other cables.
- Before installing or replacing a lens unit, make sure to remove the power plug from the outlet. Failure to do so could result in an electric shock or injury.
- Do not remove the cabinet from the projector or disassemble it. The interior of the projector contains high-voltage components as well as parts that are hot. These could cause an electric shock or burn. If inspection, maintenance or repair is required, contact a Canon dealer.
- Do not disassemble or modify the projector (including consumable parts) or the remote control.
- Do not insert any object into vents in the projector, such as the air intake vent or exhaust vents.
- Do not place a pressurized can in front of the exhaust vents. The pressure of the contents of the can may increase due to heat from the exhaust vents and this could result in an explosion.
- As strong light beams are emitted while the projector is in use, do not look directly into the projector lens. Doing so could cause an eye injury. Pay particular attention in preventing young children to do so.
- When giving a presentation in front of the projector while it is projecting an image, conduct your presentation from a position where your shadow will not be cast on the screen and where you do not feel blinded by light from the projector.

Caution

Pay attention to the following points regarding installation and handling of the projector.

- If the projector will not be used for a long period of time, be sure to remove the power plug from the power outlet to ensure safety. Failure to do so could cause a fire.
- The temperature of the cabinet around and above the exhaust vents can become hot during projector operation. Touching these areas during operation could cause burns to the hands.
Do not touch these areas. Doing so may cause burns. Pay particular attention in preventing young children from touching these parts. Additionally, do not place any metal objects on these areas. Due to the heat from the projector, doing so could cause an accident or personal injury.

 **Caution****Precautions for Installation and Handling**

- Do not place any heavy objects on top of the projector or sit/stand on it. Pay particular attention to prevent small children from doing so. The projector may be knocked over and this could result in damage or a personal injury.
- Do not place the projector on an unstable or slanted surface. Doing so may cause the projector to fall or be knocked over and could result in a personal injury.
- Do not place any objects in front of the lens while the projector is operating. Doing so could cause a fire.
- When cleaning off dust or dirt from the projector lens etc., do not use any kind of spray that is flammable. As the temperature of the lamp inside the projector is high, it could ignite, causing a fire.
- Using the lens shift function the lens in the projector moves up/down/left/right powered by a motor. Do not touch the lens when the lens is moving. Doing so could cause a personal injury.
- Before replacing the lens unit, wait at least one hour after the projector is turned off to allow the projector to cool thoroughly. Failure to do so could result in a burn or injury.
- If the projector is used for a long period of time, dust could accumulate inside the projector. This could cause a fire or malfunction. It is recommended that periodic maintenance of the projector be performed. For details of maintenance costs, contact a Canon dealer.
- When hanging the projector from a ceiling, put the projector down on the floor or a workbench before attaching or replacing the lens unit. Failure to do so could result in parts falling off the projector and may cause an accident or personal injury.

Precautions on the lamp **Warning**

When replacing the lamp, or when the lamp is damaged, pay attention to the following points. Failure to do so could result in an electric shock or personal injury.

- Be sure to remove the power plug from the power outlet before replacing the lamp.
- When the lamp is damaged, shards of glass may be scattered inside the projector. Contact a Canon dealer for cleaning and inspection of the projector interior and lamp replacement.

Caution

When handling the lamp, pay attention to the following points.

- Be sure not to handle the lamp immediately after it has been used. Be sure to switch off the power and wait for approximately 1 hour for the lamp and the projector to cool down sufficiently. Failure to do so could result in a burn or personal injury due to heat from the lamp or projector.
- When an instruction to replace the lamp has been displayed (LAMP Indicator Displays (P31)), the possibility of the lamp breaking will increase. Replace the lamp with a new one as soon as possible.
- If the lamp is damaged, gas inside the lamp (containing mercury) and dust may be emitted from the exhaust vents. If this happens, immediately open the windows and doors to provide ventilation to the room. If you inhale any gas emitted from the lamp or it has come into contact with your eyes or mouth, consult a doctor immediately.
- When disposing of a used mercury lamp, dispose of it in the same way as a fluorescent lamp and in accordance with the local regulations where you live.

Precautions for the batteries of the remote control

Warning

Pay attention to the following points regarding handling of batteries. Failure to do so could result in a fire or injury.

- Do not place the batteries in a fire or apply heat to, short circuit or disassemble the batteries.
- Do not attempt to recharge the batteries.
- Remove the batteries when they have been fully used, or if they will not be used for a long period of time.
- When replacing the batteries, replace both at the same time. Also, do not use two batteries of a different type at the same time.
- Insert the batteries in the correct +/- positions.
- If any liquid leaks from the batteries and comes into contact with skin, wash off thoroughly with water.

For Safe Use

Precautions for Carrying and Transporting Projector

- This projector is a precision instrument. Do not knock it over or subject it to impacts. Doing so may cause a malfunction.
- When carrying or holding up the projector after attaching the lens unit, be sure not to hold the lens. Doing so may cause damage.
- Do not reuse any packaging or shock-absorbent materials that were supplied with the projector at the time of purchase for transporting or shipping the projector. Protection of the projector cannot be guaranteed if used packaging or shock-absorbent materials are reused. Fragments from shock-absorbent material may also enter the interior of the projector which could cause a malfunction.
- If you need to transport the projector, contact a Canon dealer for advice.

For Safe Use

Precautions for Use

- Be sure to place install the projector in a location where the air intake and exhaust vents are separated from the wall by more than 50 cm (1.6'). Failure to do so could cause a malfunction.
- Do not install the projector in a location that is damp, or where there is a lot of dust, oily smoke or tobacco smoke. Doing so could cause contamination of optical components such as the lens and the mirror and may result in deterioration of image quality.
- Do not touch the lens with bare hands. Doing so may result in deterioration of image quality.
- If the projector is suddenly moved from a location where the temperature is low to a location where the temperature is high, or if the temperature in the location where the projector is installed increases suddenly, moisture in the air could cause condensation to form on the projector lens or mirror. This may cause a blurred image. Wait until the condensation has evaporated for the image projected to return to normal.
- Do not install the projector in a location where the temperature is high or low. Doing so may cause a malfunction.

Operating temperature: 5°C to 35°C Humidity level: up to 85%

Storage temperature: -30°C to 60°C Humidity level: up to 90%

- Do not install the projector near high-voltage electrical power lines or an electrical power source.
- Do not use the projector on a soft surface such as carpet or sponge mat, etc. Doing so could cause heat to build up inside the projector and this could result in a malfunction.
- Do not block the air intake or exhaust vents of the cooling fan. Doing so could cause heat to build up inside the projector and may cause a malfunction.
- Installing the projector in the wrong direction may cause a malfunction or accident. Install the projector so that the left/right incline is within 10°.
- Do not place any objects on top of the projector that may change shape or color due to heat.
- When using the projector at altitudes greater than 2300 m:
Contact a Canon dealer if you intend to use this projector at altitudes of 2300 m or higher.

Before Use

Table of Contents

Safety Instructions

Before Use

Projecting an Image

Useful Functions Available
During a Presentation

Setting Functions from Menus

Installation

Connecting to a Network

Maintenance

Appendix

Index

Operation

Installation and Maintenance

Appendix

Supplied Accessories

Check that the following accessories have been supplied with the projector.

- Remote control (part No.: RS-RC04)

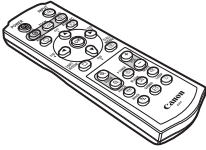

- Batteries for the remote control (AAA size x2)

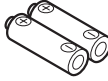

- Power cord (1.8 m)

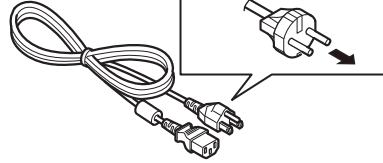

For the U.S.A. and Canada

- VGA cable (1.8 m) for connection to a computer (part No.: YH7-2307) (mini D-sub 15-pin/mini D-sub 15-pin)

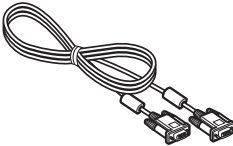

- User's Manual/ Installation Manual (CD-ROM)



- Warranty Card
- Important Information

■ Installing Remote Control Batteries

- 1** Open the battery compartment lid. Slide the lid while pressing it down.
- 2** Insert batteries. Insert 2 new AAA batteries in the compartment with the + and - poles positioned correctly.
- 3** Close the compartment lid.

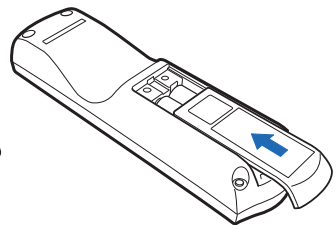
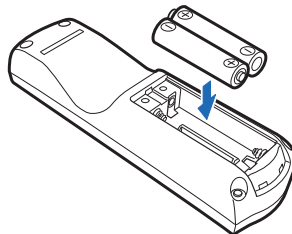
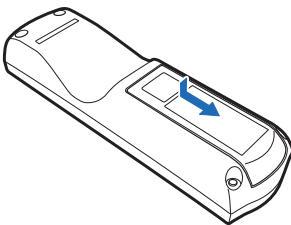

If buttons on the remote control are inoperative when you attempt to operate the projector, replace the batteries with new ones.

Preparing the Remote Control

■ Remote Control Operating Range

Point the remote control at the infrared remote receiver on the front or rear of the projector whenever pressing any button.

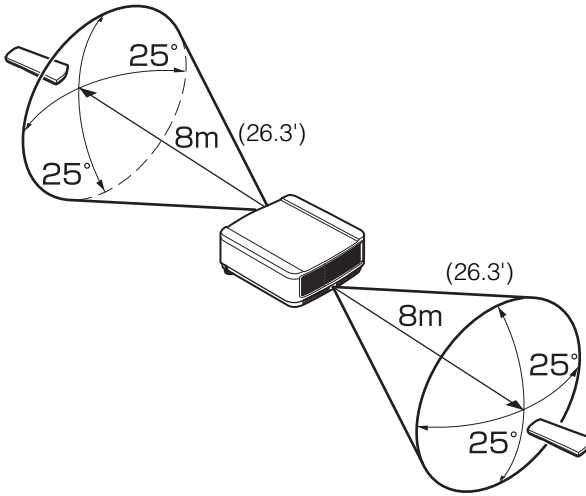

Before Use



- Use the remote control within a distance of approximately 8 m (26.3') from the projector.
- Use the remote control within an angle of 25° in any direction from directly in front of the infrared remote receiver.
- The remote control may be inoperative if there is an obstacle between the remote control and main unit or the infrared remote receiver on the main unit is exposed to direct sunlight or strong light of lighting equipment.
- When you use 2 or more projectors at the same time, you can change the channel settings to prevent the 2 remote controls from interfering with each other. (P98)

Part Names

Main Unit of Projector

■ Front Side

Power cord connector (P43)

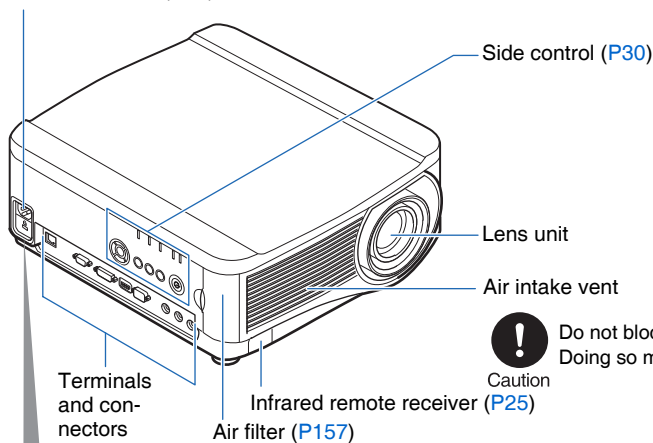

■ Rear Side

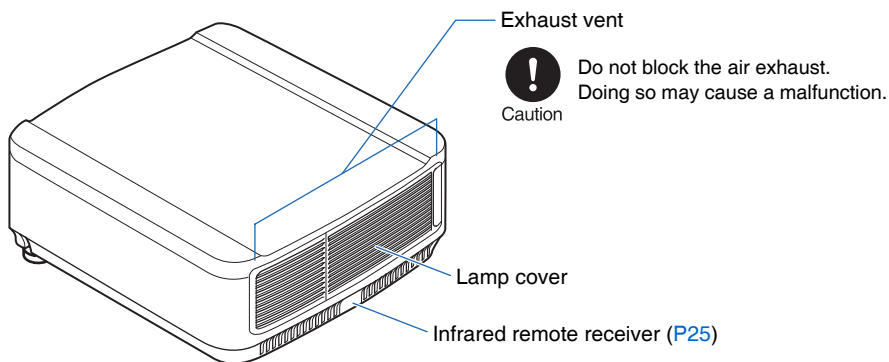

■ Bottom Side

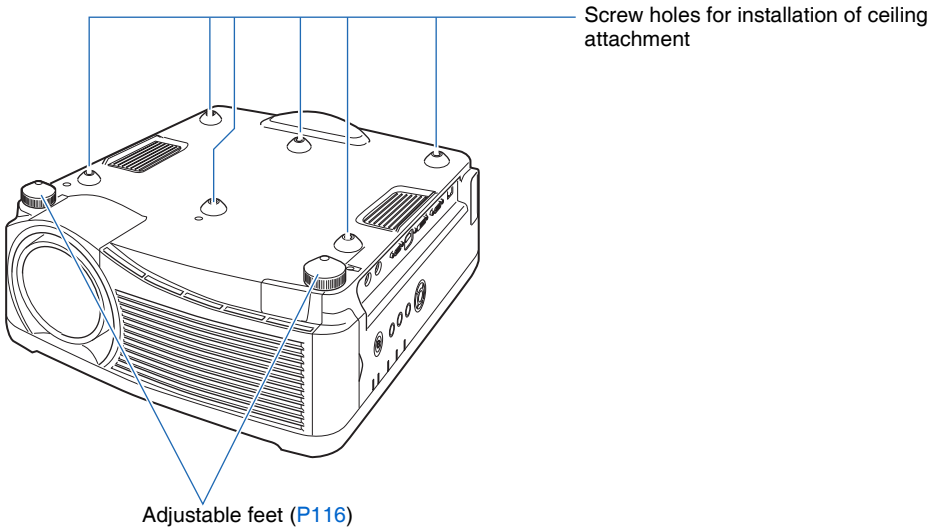

Mounting the Projector on the Ceiling

You can mount the projector on the ceiling.

The ceiling attachment (part No.: RS-CL11) is required in order to mount the projector on the ceiling. Depending on the installation environment, an extension pipe (part No.: RS-CL08 or RS-CL09) may also be required. Contact a Canon dealer where you purchased the projector for more detailed information.



- Make sure to use the optional ceiling attachment.
- You should never install the ceiling attachment by yourself.
- If you mount the projector on the ceiling, you have to invert the projected image by selecting [Image flip H/V] from the menu. (P83)

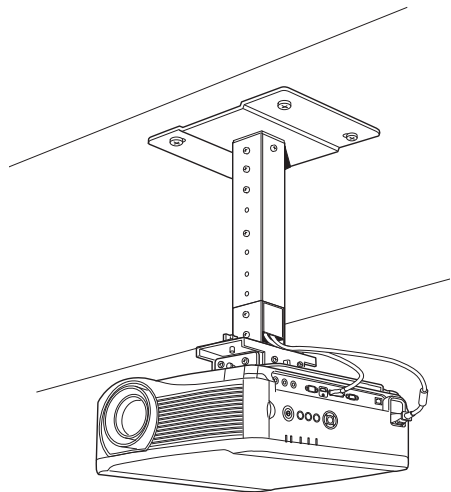

Remote Control

The projector can be operated using buttons on the remote control or the side control on the main unit.

The remote control allows you to operate all functions of the projector.

POWER button (P43, P64)

Turns the projector on or off.

FOCUS button (P57)

Adjusts focusing.

[▲] / [▶] buttons: Moves the focus position farther away.

[▼] / [◀] buttons: Moves the focus position nearer.

ASPECT button (P55)

Changes the aspect ratio mode.

D.SHIFT/KEystone button (P59)

Corrects keystone distortion.

[▲], [▼], [◀] / [▶] buttons: For keystone adjustment.

Press D.SHIFT/KEystone to correct keystone distortion.

- Moves the image up, down, left, or right when [16:9 D. image shift] or [4:3 D. image shift] is selected. (P52, P53)
- To move the image, use the [▲] / [▼] or the [◀] / [▶] buttons.

D. ZOOM button (P68)

Zooms the image in or out digitally.

[+] button: Zooms the image in (up to 12x).

[-] button: Zooms the image out (1x minimum).

[▲], [▼], [◀] / [▶] buttons: Move the zoom-in location.

FREEZE button (P66)

Freezes the projected image.

IMAGE button (P63)

Switches the image mode (image quality).

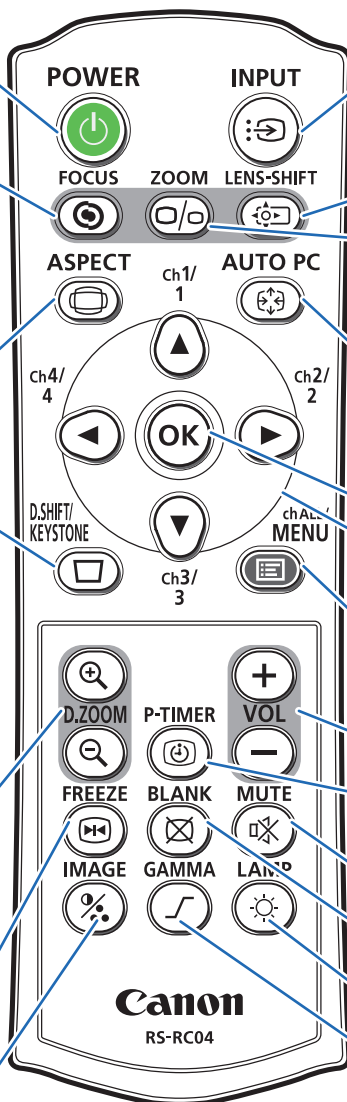

INPUT button (P47)

Switches the input signal.

ZOOM button (P56)

Adjusts the image size.

[▲] / [▶] buttons: Increase the image size.

[▼] / [◀] buttons: Decrease the image size.

AUTO PC button (P49)

Adjusts tracking etc. automatically in accordance with the signal from a computer when the analog PC input is selected.

LENS-SHIFT button (P58)

Moves the lens up, down, left, or right.

[▲], [▼], [◀] / [▶] buttons: Move the lens.

OK button (P74)

Determines the item selected from the menu.

Pointer buttons (P73)

Selects the upper, lower, left or right item in the menu and performs remote control channel settings. (P98)

MENU button (P72)

Displays the menu on the screen and performs remote control channel settings. (P98)

VOL button (P67)

Adjusts the sound volume.

[+] button: Increases the volume.

[-] button: Decreases the volume.

P-TIMER button (P69)

Displays the time elapsed since this button was pressed.

MUTE button (P67)

Mutes the sound.

BLANK button (P66)

Toggles between display/non-display of image.

LAMP button (P95)

Toggles the lamp mode between Standard and Silent.

GAMMA button (P89)

Adjusts the gamma of the image.

[▶] button: Corrects dark parts of the image so that they are easier to see.

[◀] button: Corrects bright parts of the image so that they are easier to see.

Side Control

(1) LED indicators (P31)

Illuminate to indicate the projector status.

For indicator status, refer to “LED Indicator Displays” (P31).

- POWER ON (green): Lights up or flashes when the power is on.
- STAND BY (red) : Lights up or flashes during standby or when the projector is shut down.
- WARNING (red) : Lights up or flashes when an error occurs.
- LAMP (orange) : Flashes when the time for replacing the lamp is near. Also lights up together with the [WARNING] indicator (constantly lit) when a lamp malfunction or lamp cover malfunction has occurred.
- TEMP (red) : Lights up together with the [WARNING] indicator (constantly lit) when a temperature error has occurred. Flashes when the temperature inside the projector is high.

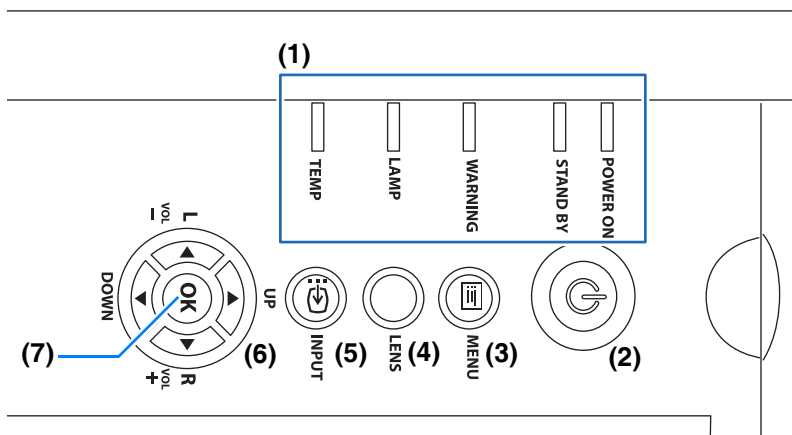

(2) POWER button (P43, P64)

Turns the projector on or off.

(5) INPUT button (P47)

Switches the input signal.

(3) MENU button (P72)

Displays a menu on the screen.

(6) Pointer/VOL buttons (P73)

Adjust the sound volume.

[◀] button: Decreases the volume.

[▶] button: Increases the volume.

(4) LENS button

Each time the button is pressed, the screen changes to focus adjustment (P57), zoom (image size) adjustment (P56), or lens shift (image position) adjustment (P58). To adjust, use the [▲] / [▼] or the [◀] / [▶] buttons.



















































(7) OK button (P74)

Determines the item selected from the menu.

LED Indicator Displays

The illumination status of the LED indicators indicates the operating status of the projector.

: Off : Lit : Flashing

Status	LED indicator				
	POWER ON (green)	STANDBY (red)	WARNING (red)	LAMP (orange)	TEMP (red)
Power is not connected.					
Ready to turn power on (standby).					
Power is on.					
Power-saving mode engaged.					
Replace the lamp.	 *	 *			
Internal temperature is high.					
A lamp error has occurred.					
Power was turned off due to high internal temperature.					
The lamp cover is open.					
Another error has occurred.					

* Either the [POWER ON] or [STAND BY] indicator lights up, depending on the power status.

Input Terminal

(1) LAN port (P130)

Connects the LAN cable.

Used to connect the projector to a network.

(2) ANALOG PC/COMPONENT IN Terminal

(1 /COMPONENT IN) (P37, P41)

Receives the analog PC signal (Analog PC).

A component cable can be used to receive the component image signal (Component).

(3) DVI-D IN Terminal (2 DVI-D IN) (P38)

Connects the external monitor output from a computer.

Receives the digital signal (Digital PC).

(4) HDMI IN Terminal (HDMI IN) (P39)

Receives the digital content image signal (HDMI).

Carries both video and audio signals across a single cable.

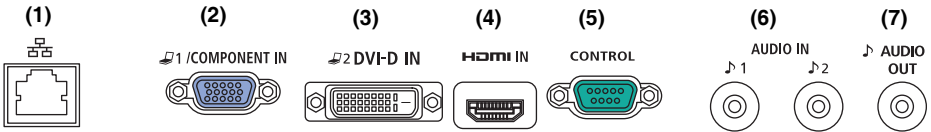

(5) Service Port (CONTROL)

This terminal is used by servicing technicians. It is not used during ordinary use.

(6) AUDIO IN Terminal (AUDIO IN) (P37, P38, P41)

Receives the audio input corresponding to 2 image input systems other than HDMI IN.

The internal speaker outputs the audio signal for the selected image signal.

(7) AUDIO OUT Terminal (1 AUDIO OUT) (P39, P42)

Outputs the audio to external AV equipment. This outputs the audio signal that corresponds to the projected image signal.

MULTIMEDIA PROJECTOR
WUX4000

Operation



Projecting an Image

Table of Contents

Safety Instructions

Before Use

Projecting an Image

Useful Functions Available
During a Presentation

Setting Functions from Menus

Installation

Connecting to a Network

Maintenance

Appendix

Index

Operation

Installation and Maintenance

Appendix

Steps for Connecting the Projector and Projecting an Image

⚠ Installation work will be performed by a qualified technician or Canon dealer where the projector was purchased.

Connecting the Projector to Equipment (P126)



Starting Projection (P43)



Do you want to project an image from a notebook computer?



For a notebook computer, turn on the monitor output (P45) and then proceed.

Selecting an Input Signal (P46)

Is the image projected properly?

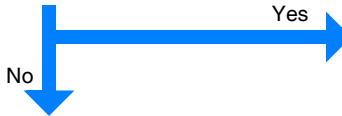

Projection is complete.

Adjusting the Image (P48)

Make the following adjustments.

- Setting the Display Resolution of the Computer (P48)
- Selecting an Aspect Ratio of Projected Image (Screen aspect) and a Screen Mode (Aspect) (P50, P54)
- Adjusting Misaligned Images or Flickering of the Screen Using the Auto PC (P49)
- Adjusting the Image Size (P56)
- Adjusting the Focus (P57)
- Adjusting the Image Position (Lens shift) (P58)
- Adjusting Keystone Distortion (P59)

Making Fine Adjustments

- Selecting an Image Mode (P62)

Connecting the Projector

Connecting the Projector to a Computer

Connect the projector to the computer.

Before connecting the cables, turn off both the projector and computer.

A digital connection (P38) is recommended when projecting a WUXGA or UXGA image in high quality.

When using a computer with an HDMI output terminal, a digital connection (P39) can be made using an HDMI cable.

■ Connecting to RGB Monitor Output Terminal (Analog Connection)

VGA cable (Input signal type: [Analog PC] – P46)

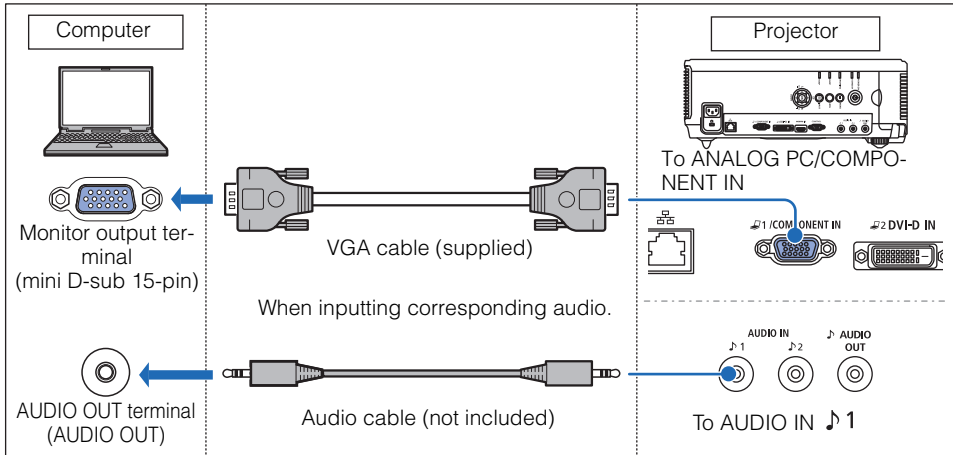

- Use a VGA cable in which all pins are connected. If the cable is a type in which all pins are not connected, the image may not be correctly displayed.
- Use an audio cable without a built-in resistor. Using an audio cable with a built-in resistor will reduce the audio volume.

Connecting the Projector

BNC cable (Input signal type: [Analog PC] – P46)

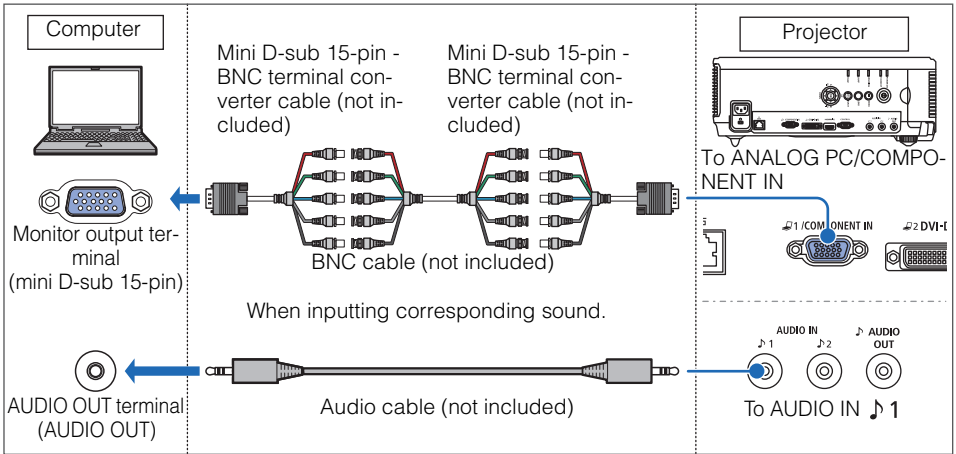

- A signal with a dot clock of 162 MHz or higher cannot be projected.
- Use an audio cable without a built-in resistor. Using an audio cable with a built-in resistor will reduce the audio volume.

■ Connecting to DVI Monitor Output Terminal (Digital Connection)

DVI cable (Input signal type: [DVI-D] (Digital PC) – P46)

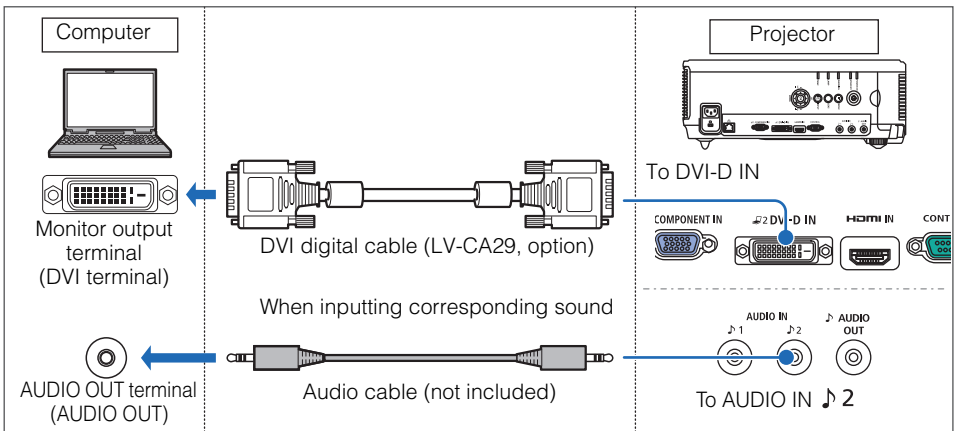

- Use an audio cable without a built-in resistor. Using an audio cable with a built-in resistor will reduce the audio volume.

■ HDMI cable (Input signal type: [HDMI] – P46)

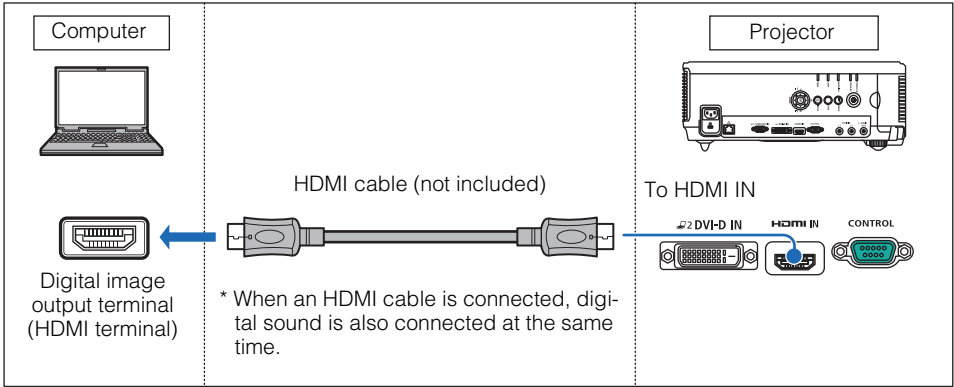

■ Outputting Audio to Speakers

It is possible to output audio from the projected images to amplified speakers.

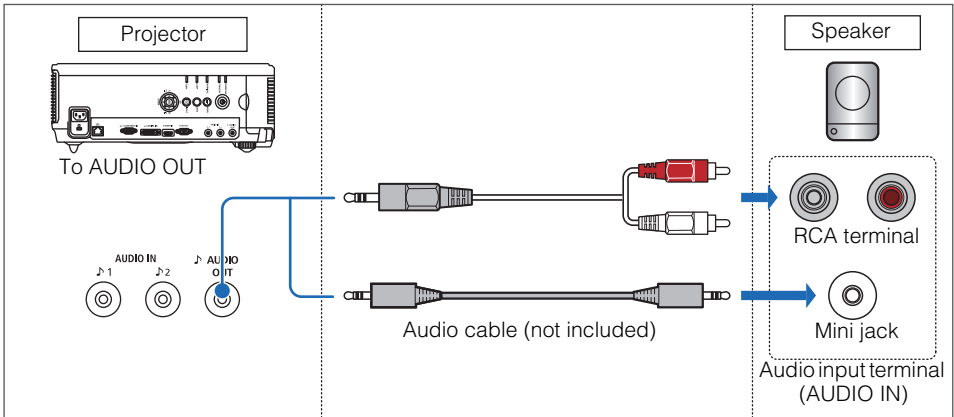

Use an audio cable without a built-in resistor. Using an audio cable with a built-in resistor will reduce the audio volume.

Connecting the Projector

Connecting to AV Equipment

Connect the projector and AV equipment.

Before connecting the cables, turn off both the projector and AV equipment.

The description provided here is one example. For more detailed information, refer to the manual for the connected AV equipment.

■ Connecting to Digital Video Output Terminal (Digital Connection)

HDMI cable (Input signal type: [HDMI] – P46)

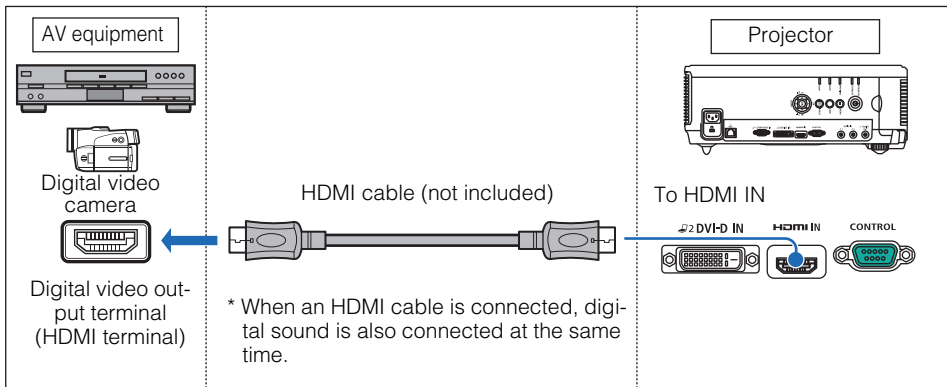

■ Connecting to Analog Video Output Terminal (Analog Connection)

Component cable (Input signal type: [Component] – P46)

A component video signal from the AV equipment can be inputted into the projector by connecting the component cable to the ANALOG PC/COMPONENT IN terminal of the projector.

Use a commercially available component cable that fits the terminal type of the AV equipment to create a relay connection.

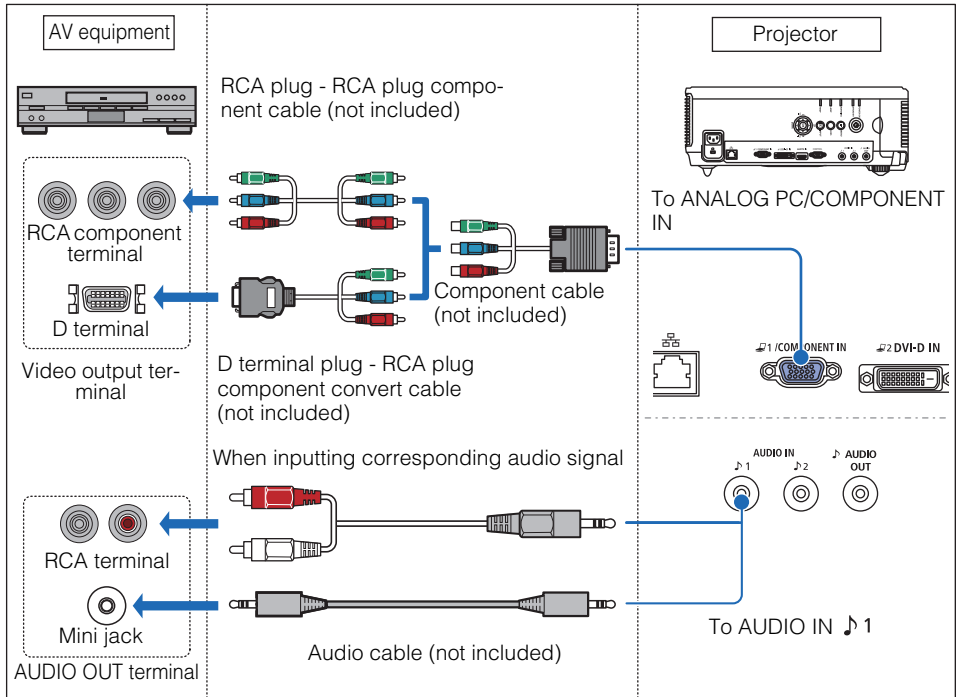

Use an audio cable without a built-in resistor. Using an audio cable with a built-in resistor will reduce the audio volume.

Connecting the Projector

■ Outputting Audio to Speakers

It is possible to output audio from the projected images to AV equipment or amplified speakers.

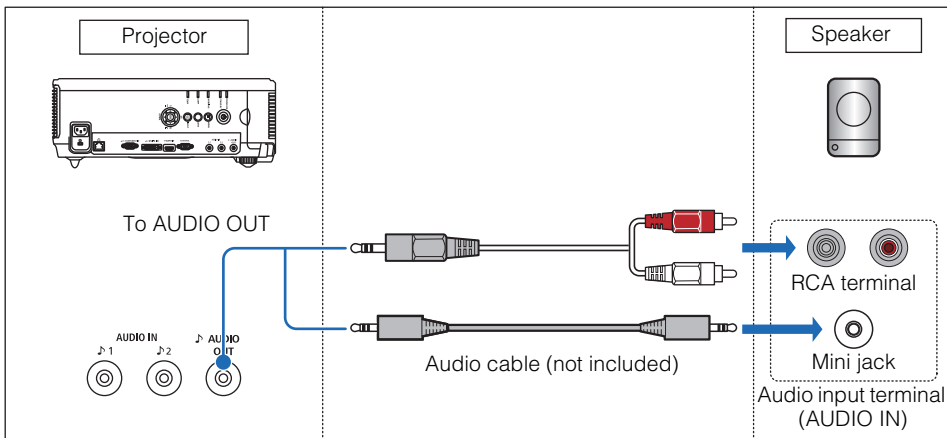

Use an audio cable without a built-in resistor. Using an audio cable with a built-in resistor will reduce the audio volume.

Starting Projection

- 1 Check the connection between the projector and the computer or AV equipment. (P40 – P42)
- 2 Connect the power cord and make sure that the [STAND BY] indicator is lit (red).

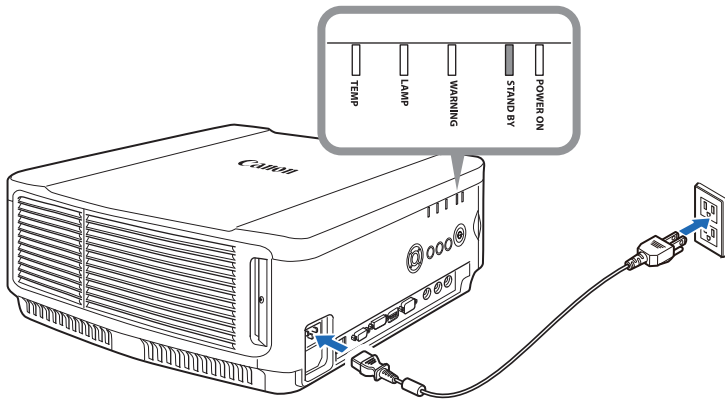

- Fully insert the power cord plug into the socket.
- Connect the ground terminal on the power plug to ground. Otherwise, an electric shock may result or the computer may suffer electromagnetic interference or be subject to poor TV and radio reception.
- After turning off the projector, wait at least 5 minutes before turning it on again. It may shorten the lamp life if you turn on the projector immediately after turning it off.
- To save power, unplug the power cord when not in use.

- 3 Press the **POWER** button.
The [POWER] indicator flashes green, and then stops flashing and remains lit.

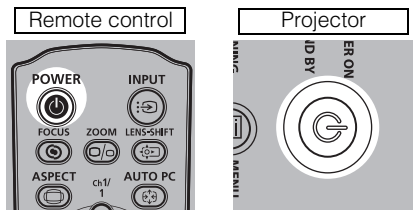

The countdown window is displayed for approximately 20 seconds, and then the projection is started. Press the **OK** button to make the countdown window disappear.

- 4 Turn on the computer or AV equipment power.

Starting Projection

Changing Operations When Projector is Turned On

You can change operations when the projector is turned on as follows.

- You can turn on the projector by connecting the power cord, without pressing the **POWER** button. (P96)
- You can change the countdown window. (P85)
- You can skip the countdown window. (P43)

Using the Power Saving Mode (Power Management)

When you enable the power management mode, the lamp is automatically turned off if the projector receives no signal input for a certain period of time. (P96)

■ When the Language Selection Screen Appears

A window appears when the projector is turned on for the first time. You can select a language to be used by the projector for displaying menus and messages in the window. Select the desired language with the pointer buttons and press the **OK** button.

You can change the language from the menu at a later time. (P99)

If the language selection screen is out of focus, press the **FOCUS** button to perform focus adjustment.

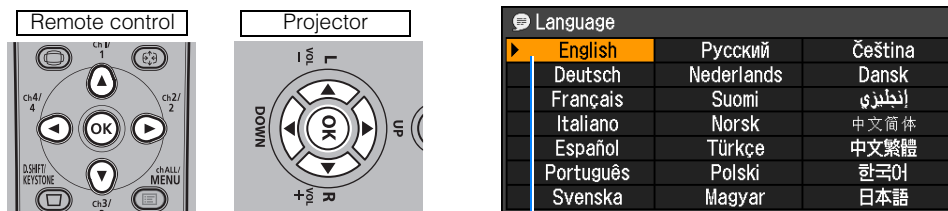

An item highlighted in orange will be selected.

■ When the Password Input Screen Appears

If you have set a password, the Password input screen appears. Enter your password. (P101)

■ When “No signal” Appears

With a notebook computer, the user must turn on the external monitor output. (P45)
Press the **INPUT** button to select the input signal. (P47)

■ When Notebook Computer Screen Does Not Appear

Set your notebook computer to output signals to an external monitor. For more details, refer to “Changing Notebook Computer Screen Output” below.

■ Adjusting Image

- For the display resolution of the computer, select “1920 x 1200 pixels” or the resolution closest to the output signal resolution of the computer. (P48)
- Use the auto PC function to adjust shift in computer image or the flickering of the screen. (P49)
- Use the **ZOOM** button to adjust the size of the projected image. (P56)
- Use the **FOCUS** button to correct the focus adjustment if necessary. (P57)
- Use the **D.SHIFT/KEystone** button to adjust keystone correction if necessary. (P59)
- Select the aspect ratio of the projected image (screen aspect) or a screen mode (aspect) according to the aspect ratio of the screen, type of input image signal etc. (P50 - P55)
- Select an image mode depending on the projected image. (P62)

Changing Notebook Computer Screen Output

With a notebook computer, the user must turn on the external monitor output on the computer side.

This operation is not required for a desktop computer.

■ Turning on External Monitor Output

You can turn on the external monitor output via keyboard operation.

To turn on the external monitor output with most computers, press the function key ([F1] to [F12]) which is marked with the external monitor icon while holding down the [Fn] key.

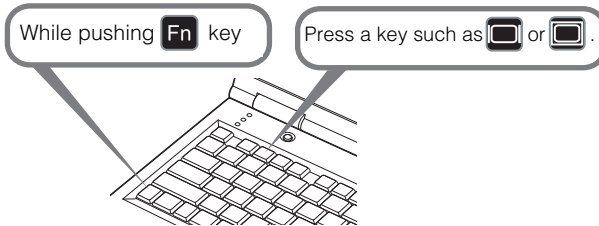

- The function key you use and the method used to turn on the external monitor output vary depending on the model. For details, see the instructions for your notebook computer.
- With Windows 7, you can turn on image output by holding down the Windows logo key and pressing the [P] key.





Selecting an Input Signal (INPUT)

Select the input signal in the [Input] menu when you want to project a digital PC or AV equipment signal, or to switch between inputs when multiple computers or multiple sets of AV equipment are connected.

Skip this step if you have not changed the input signal since the last projection.

■Types of Input Signals

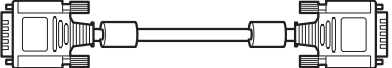
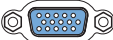
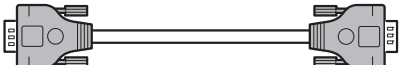
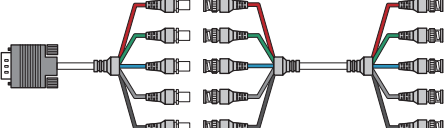
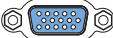
The table below shows the relationship among input signals supported by the projector, input terminals and connection cables.

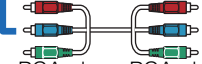
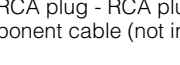
Input signal	Input terminal	Types of connection cables
HDMI	HDMI IN 	HDMI cable (not included) 
Digital PC	DVI-D IN 	DVI digital cable (LV-CA29, option) 
Analog PC	ANALOG PC/ COMPONENT IN 	VGA cable (supplied) 
		BNC cable (not included)  Mini D-sub 15-pin - BNC terminal converter cable (not included) BNC cable (not included)
Component	ANALOG PC/ COMPONENT IN 	Component cable (not included)  D terminal plug - RCA plug component conversion cable (not included)  RCA plug - RCA plug component cable (not included) 

■ Selecting an Input Signal

1 Press the INPUT button to display the window shown on the lower right.

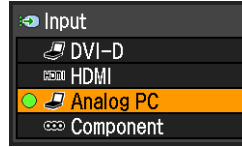
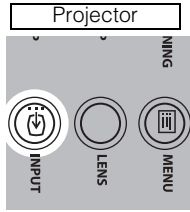
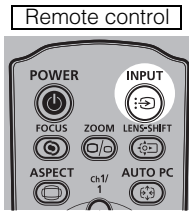

The currently active input signal is marked with a circle and highlighted in orange. An input signal that is ready for projection is displayed in white. When no signal is received, it is displayed in gray. [HDMI], [DVI-D] (Digital PC) and [Analog PC] may be displayed in gray even if they are ready for projection.

2 You can switch the available input signal types by pressing the INPUT button.

- You can select the target input signal with [▲] / [▼].
- Only the input signals displayed in white can be selected.

3 Press the OK button to confirm the input signal type.

Adjusting the Image

Setting the Display Resolution of the Computer

Based on the performance of the projector (resolution: 1920 x 1200 pixels), set the display resolution of the computer to “1920 x 1200 pixels” or the resolution closest to the output signal resolution of the computer. (P173)

■ Windows 7

- 1 Open the [Control Panel] from the start menu, then select [Appearance and Personalization] - [Adjust screen resolution] in the [Control Panel Home].
- 2 Click the [Resolution] tab, and move the slider to select “1920 x 1200 pixels” or the resolution closest to the output signal resolution of the computer.
- 3 Click the OK button.

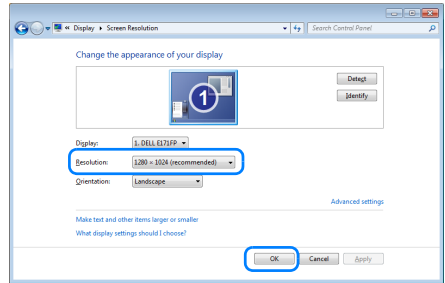

■ Windows Vista

- 1 Open the [Control Panel] from the start menu, then select [Appearance and Personalization] - [Adjust screen resolution] in the [Control Panel Home].
- 2 Select “1920 x 1200 pixels” or the resolution closest to the output signal resolution of the computer.
- 3 Click the OK button.

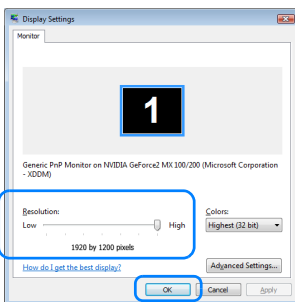

■ Windows XP

- 1 Right-click on the desktop background and select [Properties] to open the [Display Properties].
- 2 Click the [Settings] tab, and under [Screen Resolution], select “1920 x 1200 pixels” or the resolution closest to the output signal resolution of the computer.
- 3 Click the OK button.

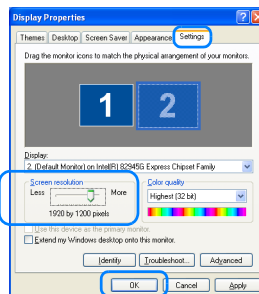

Mac OS X

- 1 Open the Apple Menu and select [System Preferences].
- 2 In the [System Preferences] window, click the [Displays] icon to display the Display window.
- 3 Select the [Display] tab and select “1920 x 1200” or the resolution closest to the output signal resolution of the computer from the [Resolutions] list.
- 4 Close the [System Preferences] window.

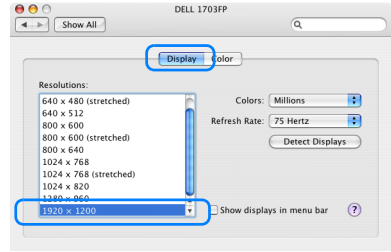

AUTO PC

If the image display is shifted or there is flickering of the screen when [Analog PC] is selected, press the **AUTO PC** button to adjust the projector to the optimal condition. The adjustment results will be stored. If the projector is used again with the same computer, when the input signal is selected the image will be projected automatically under the same conditions that were previously adjusted.

Performing the Auto PC Function

Press the **AUTO PC** button to perform projector adjustment.

Remote control

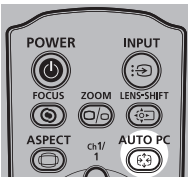

If the projected image was not properly adjusted with the Auto PC function, perform the following steps.

- From [Input signal select], select an input signal type based on the resolution of the computer. (P76)
- If the adjustment is still insufficient, from [Input signal settings] select [Total dots], [Tracking], [Horizontal position], [Vertical position], [Horizontal pixels] and [Vertical pixels] to make adjustments. (P77 - P79)
- For the signal types supported by the projector, see the table on page 173.

Adjusting the Image

Selecting Screen Aspect and Aspect

Select an optimum aspect ratio of the projected image (screen aspect) or an optimum screen mode (aspect) according to the aspect ratio of the screen, type of input image signal and so on for the projection to make best use of the screen size.

- [Screen aspect] Select the same screen aspect ratio as the screen you are using.
- [Aspect] In general, select [Auto].

You may need to change the setting depending on the resolution of the computer. If the image is not projected with the desired aspect ratio, see “Relationship between Aspect and Screen Aspect” on page 171.

■ Selecting Screen Aspect

Select the correct aspect ratio for the screen which is used.
Perform the following steps to select the aspect ratio of the projected image.

1 Press the MENU button to display a menu window.

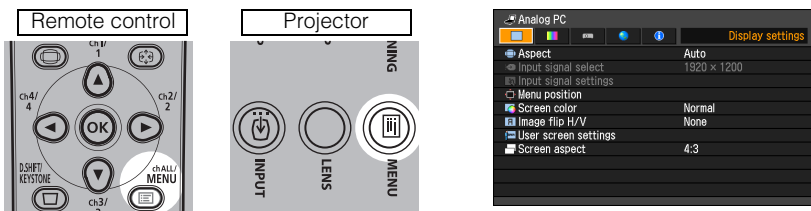

2 Use the [◀] / [▶] buttons to select the [Display settings] tab.

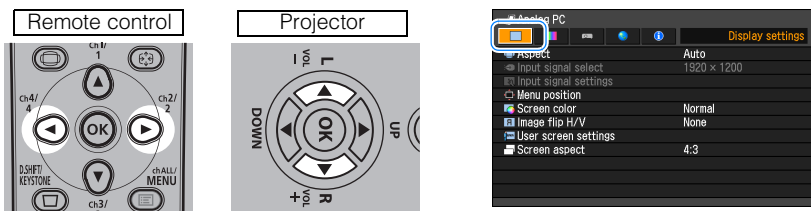

3 Select [Screen aspect] with the [▲] / [▼], and then press the OK button.

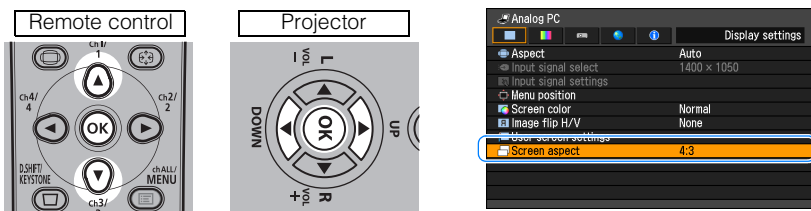

4 Use the [▲] / [▼] buttons to select the desired contents.

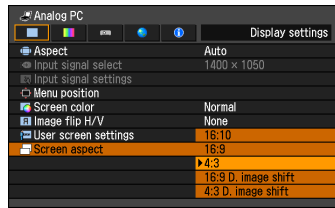
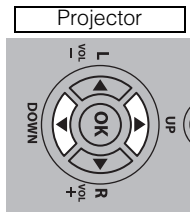
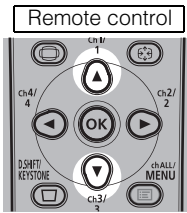

16:10

Select this when you use a screen with aspect ratio of 16:10. Also, select this when you project an image on a wall.

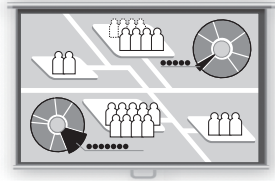

16:9

Select this when you use a screen with aspect ratio of 16:9.



4:3

Select this when you use a screen with aspect ratio of 4:3.

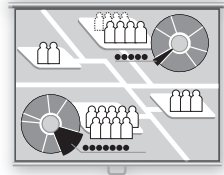

16:9 D. image shift

Select this when you use a screen with aspect ratio of 16:9. This is also recommended when projecting visual software with an aspect ratio of 16:9.

You cannot correct the keystone distortion in this mode, but you can move the image up or down with images being projected horizontally.

For the details on how to move the image, refer to page [52](#).

4:3 D. image shift

Select this when you use a screen with aspect ratio of 4:3. This is also recommended when projecting visual software with an aspect ratio of 4:3.

You cannot perform the keystone adjustment in this mode; however, you can move the image to the left or right while projecting the image horizontally.

For the details on how to move the image, refer to page [53](#).

5 Press the OK button to confirm your setting and then press the MENU button.

Adjusting the Image

Moving Image with 16:9 D. Image Shift

- 1 Press the D.SHIFT/KEYSTONE button when [16:9 D. image shift] is selected as the screen aspect in order to display the window shown on the lower right.

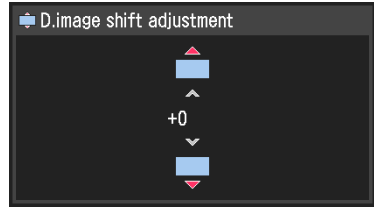
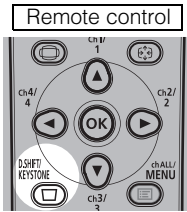

- 2 Use the [▼] / [▲] buttons to move the image. The minimum value is -60, and the maximum value is +60.

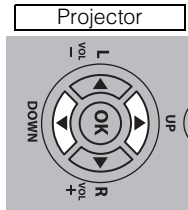
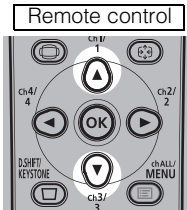

[▲] button
Moves image up



[▼] button
Moves image down



- 3 When image shift adjustment has been completed, press the OK button.

Moving Image with 4:3 D. Image Shift

- 1 Press the D.SHIFT/KEYSTONE button when [4:3 D. image shift] is selected as the screen aspect in order to display the window shown on the lower right.

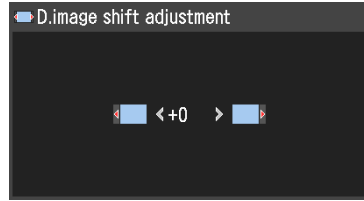
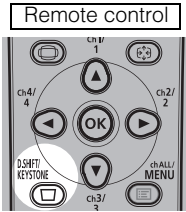

- 2 Use [◀/▶] to move the image. The minimum value is -60, and the maximum value is +60.

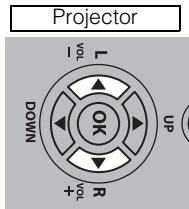
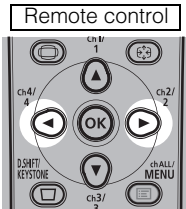

[◀] button

Moves the image left

[▶] button

Moves the image right



- 3 When image shift adjustment has been completed, press the OK button.

Resetting the Image Shift

Perform the following steps to reset the image shift adjustment.

Press the D.SHIFT/KEYSTONE button twice to display the [D. image shift reset] window. On the window, select [OK] with the [◀] button, and then press the OK button.

Adjusting the Image

■ Selecting Aspect Ratio

Select the aspect ratio of projected image based on the input signal type, aspect ratio of the screen and resolution.

For more details, refer to page 171 "Relationship between Aspect and Screen Aspect".

Types of Aspect Ratios

Auto

The image is projected at the aspect ratio of the input signal. Select this mode for normal image projection.

Full

The image is projected using an input signal aspect ratio of 16:10.

Select this to project computer screen images having an aspect ratio of 16:10 (WUXGA, WSXGA+, WXGA+ and WXGA (1280 x 800)) fully on the screen.

16:9

The image is projected using an input signal aspect ratio of 16:9. Select this if an image of 16:9 aspect ratio cannot be correctly projected in [Auto] mode.

4:3

An image is projected using an input signal aspect ratio of 4:3. Select this if an image of 4:3 aspect ratio cannot be correctly projected in [Auto] mode.

Zoom

The image with 4:3 aspect ratio is projected in the center of the screen enlarged to a 16:9 aspect ratio, with the upper and lower portions of the image cut off. Select this when projecting visual software which has an aspect ratio of 4:3 and black bars at the top and bottom of the image.

- This mode is available when you select [16:10], [16:9] or [16:9 D. image shift] for [Screen aspect] and select [HDMI (480p, 576p)] or [Component (480p, 480i, 576p, 576i)].

True size

The image is projected with the original resolution of the input signal. Select this to clearly project a computer screen image which has a resolution of WUXGA or lower.

- This mode is available when you select [Analog PC] or [Digital PC] for the input signal.
- This mode is also available when you select [HDMI (480p, 576p, 720p, 1080i, 1080p)] and [Component (480p, 576p, 720p, 1080i, 1080p)].

How to Select an Aspect Ratio

Press the **ASPECT** button on the remote control and select an appropriate aspect ratio. Press the **ASPECT** button to change the aspect ratio type.

For more details on the aspect ratios, refer to page 171 "Relationship between Aspect and Screen Aspect".

Remote control

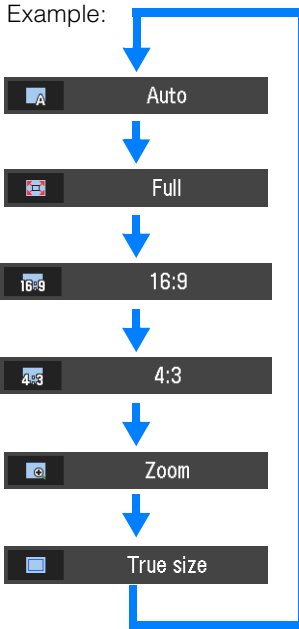
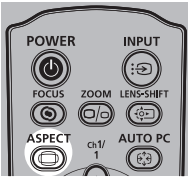

You can also select any aspect ratio from the menu. (P75)



Some aspect ratios may not appear depending on the type of input signal.

Adjusting the Image

Adjusting the Image Size

The size of the projected image can be adjusted by pressing the **ZOOM** button on the remote control or the **LENS** button on the projector.

Change the projector installation position if your desired image is too large or too small to adjust it with the zoom function. (P123)

- 1 Press either the **ZOOM** button on the remote controller or the **LENS** button on the projector twice in order to display the window shown at lower right.

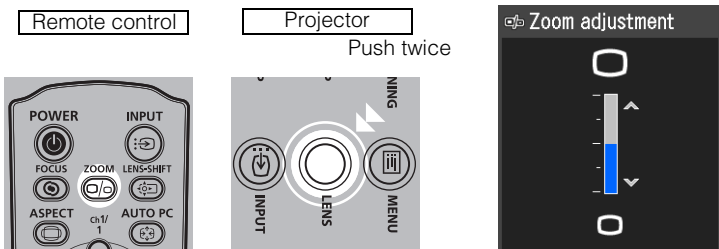

- 2 Press the pointer buttons to adjust the image size.

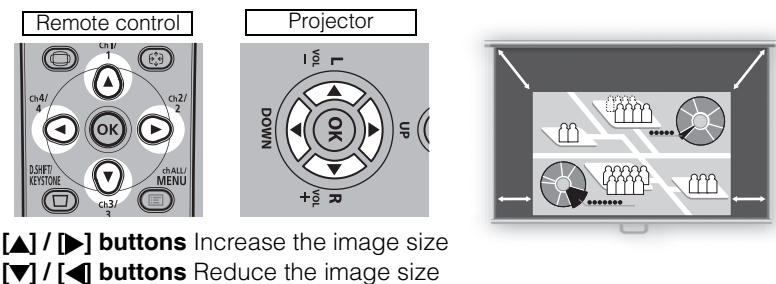

- 3 When the desired image size is selected, press the **OK** button or the **ZOOM** button.

Adjusting the Focus

To adjust the focus, press the **FOCUS** button on the remote control or the **LENS** button on the projector.

With the Standard Zoom Lens / Long Zoom Lens / Short Fixed Lens, the projection image may be out of focus if the projection distance is not within the range of approx. 1.3 m - 9.6 m (4.3' - 31.5') / 1.9 m - 14.2 m (6.2' - 46.6') / 0.7 m - 5.2 m (2.3' - 17.1'). Move the projector installation position if such is the case. (P123)

- 1 Press either the **FOCUS** button on the remote control or the **LENS** button on the projector in order to display the window shown on the lower right.

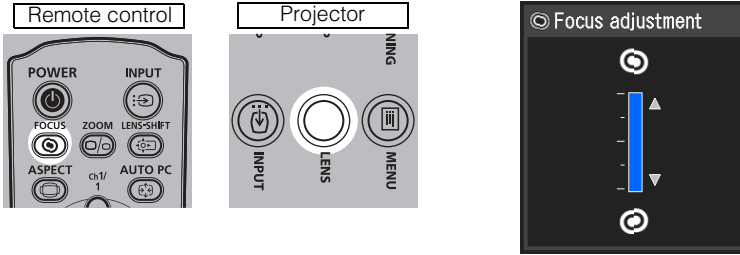

- 2 Press the pointer buttons to adjust the focus.

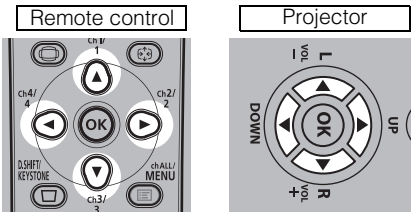

- [▲] / [▶] buttons Move the focus position farther away
- [◀] / [▼] buttons Move the focus position nearer

- 3 When the focus is adjusted optimally, press the **OK** button or the **FOCUS** button.

Adjusting the Image

Adjusting the Image Position

To adjust the screen position up, down, left, or right, press the **LENS-SHIFT** button on the remote control or the **LENS** button on the projector. This function is referred to as “lens shift” because the position of the projected image is changed by moving the lens position.

- ◆ The available range for lens shift (percentage of movement relative to the screen size) varies depending on the lens unit which is used.
Standard Zoom Lens (RS-IL01ST): Down 15% - Up 55%, Left 10% - Right 10%
Long Zoom Lens (RS-IL02LZ): Down 15% - Up 55%, Left 10% - Right 10%
Short Fixed Lens (RS-IL03WF): Down 5% - Up 5%, Left 2% - Right 2%
- There are areas where each lens is unable to move. With the Standard Zoom Lens and the Long Zoom Lens, the areas are at the top left and top edges. With the Short Fixed Lens, the areas are at the four corners.

1 Press either the **LENS-SHIFT** button on the remote control or the **LENS** button on the projector 3 times in order to display the window shown on the lower right.

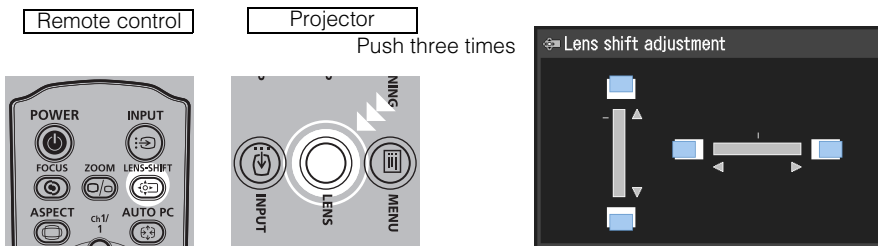

2 Press the pointer buttons to adjust.

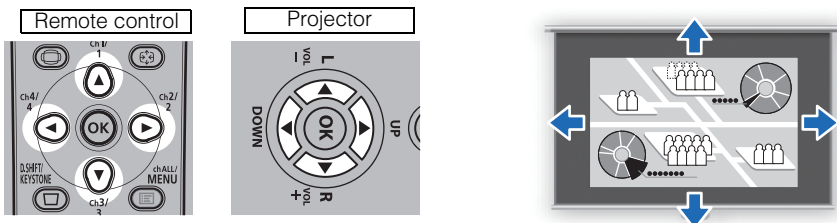

3 When the desired position is reached, press the **OK** button.

■ Resetting the Position

The lens position after movement with the lens shift function is not returned when the power is turned off. To return it to its original position, perform reset.

During screen position adjustment, press and hold the **LENS-SHIFT** button on the remote control or the **LENS** button on the projector to display the [Lens shift Reset] window.

The selections for the lens currently used are displayed. Use the pointer buttons to select one, then press the **OK** button.

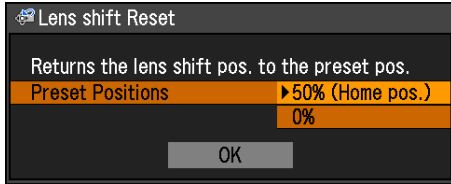

Lens unit type	Available items
Standard Zoom Lens RS-IL01ST	Home position (50%) : Up 50%, left/right 0% (0%) : Up/down/left/right 0%
Long Zoom Lens RS-IL02LZ	
Short Fixed Lens RS-IL03WF	Home position (0%) : Up/down/left/right 0%

Adjusting Keystone Distortion

The **D.SHIFT/KEystone** button can be used to correct keystone distortion.



- Keystone can be adjusted within the range of ± 20 degrees. If the keystone distortion is too large to adjust, move the projector installation position. (P114)
- The result of keystone adjustment is stored in memory. If you place the projector in the same position, the keystone adjustment is not necessary.
- Signals are processed digitally when keystone distortion is corrected. The image may look different from the original one. In addition, the aspect ratio of the image may change.
- Perform keystone distortion correction with the lens shift position in the home position. Correction will not be performed correctly if the position is not the home position.

Adjusting the Image

- 1** Press the D.SHIFT/KEYSTONE button to display the window shown on the lower right.

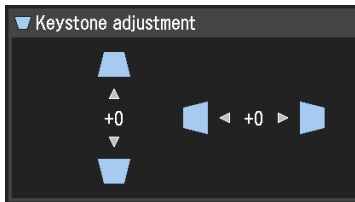
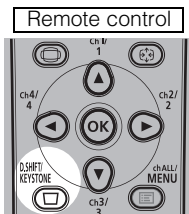

- 2** Press the pointer buttons to adjust.

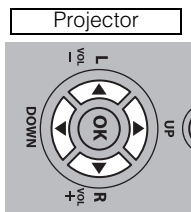
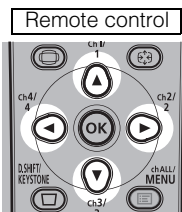

[▲] button

Reduces the length of the upper edge

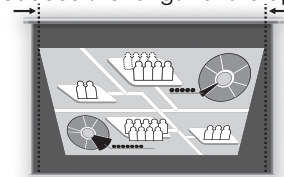

[▼] button

Reduces the length of the lower edge

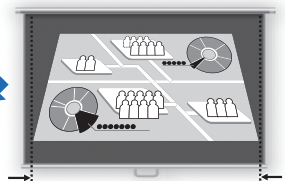

[◀] button

Reduces the length of the left edge

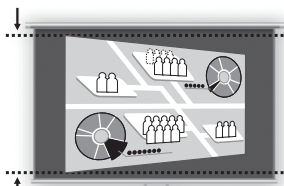

[▶] button

Reduces the length of the right edge

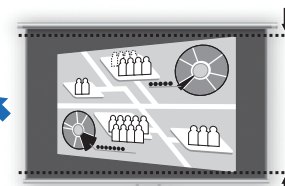

- 3** When the keystone distortion has been corrected, press the OK button.

■ Resetting the Keystone Adjustment

Perform the following steps to reset the keystone adjustment.

Press the **D.SHIFT/KEystone** button twice to display the [Keystone reset] window.

On the window, select [OK] with the [**◀**] button, and then press the **OK** button.

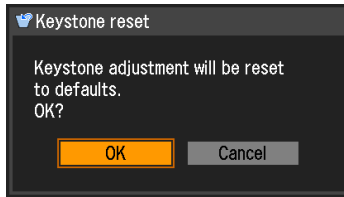

Selecting an Image Mode

You can select an image mode to suit the projected image.

In each image mode, you can further adjust the brightness, contrast, sharpness, gamma, color adjustment, advanced adjustment, and lamp mode. (P86)

■ Image Modes

The image modes which can be selected vary somewhat depending on the selected input signal.

Image Mode	Compatible input signals		Explanation
	Digital PC Analog PC HDMI ([Computer])	Component HDMI ([Auto])	
Standard	○	○	This image mode emphasizes white tones and projects an image that is close to the original in quality. It is suited to project computer screens or visual software (moving pictures) in a bright room.
Presentation	○	—	This image mode is suitable for text-based images such as those used in a presentation in a dimly lit room.
Dynamic	—	○	Suitable for viewing visual software (moving pictures) in a slightly brighter room.
VividPhoto	○	—	Select for an image where color saturation is prioritized. Suitable for viewing in a slightly darker room.
Photo/sRGB	○	○	This mode conforms to sRGB standards. It is suitable for projecting picture images taken with an sRGB-compatible digital camera.
Video	—	○	Suitable for viewing video taken with a video camera in a slightly darker room.
Cinema	—	○	Select for image quality that is suitable for ordinary visual software (moving pictures). This mode allows viewers to easily enjoy the atmosphere of a movie theater in a dim room.
User 1 - 5	○*	○*	* Up to 5 user-selected combinations of image quality settings can be stored in the memory. (P87) Stored settings can be selected as an image mode.

○: Compatible —: Not compatible

■ How to Select an Image Mode

Press the **IMAGE** button on the remote control to select.

The image mode changes each time the **IMAGE** button is pressed. (The displayed image modes vary depending on the selected input signal.)

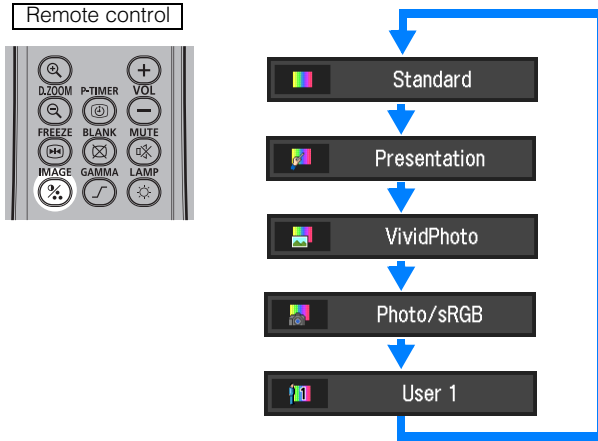

You can also select any image mode from the [Image mode] menu. (P86)

- User settings 1 - 5 are displayed when the desired image settings have been created and stored using the user memory function in the image adjustment menu. (P87)

Turning Off the Projector

1 Press the **POWER** button to display the window shown on the lower right.

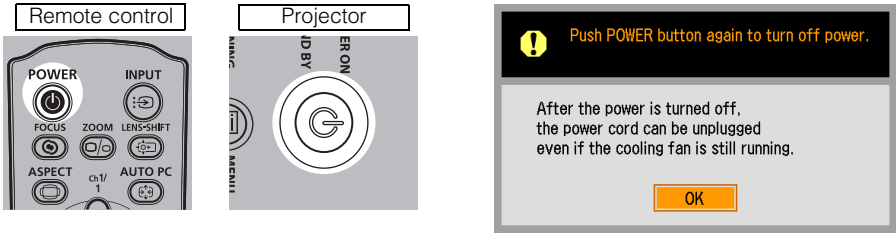

When this window is displayed, press the **POWER** button again to turn off the power. The lamp goes off, the [STAND BY] indicator starts flashing in red and the cooling process starts.

- ❗ You cannot turn the projector on while the cooling process is in operation.
- If you want to continue projecting without turning off the power, press a button other than **POWER**, or else wait until the confirmation message disappears.
- After turning off the projector, wait at least 5 minutes before turning it on again. It may shorten the lamp life if you turn on the projector immediately after turning it off.
- Using the projector for a long time may shorten the life of the lamp and internal optical components.

2 Disconnect the power cord from the AC outlet.

If the power plug is left connected, the [STAND BY] indicator will switch from flashing to constantly illuminated after the cooling process is completed.

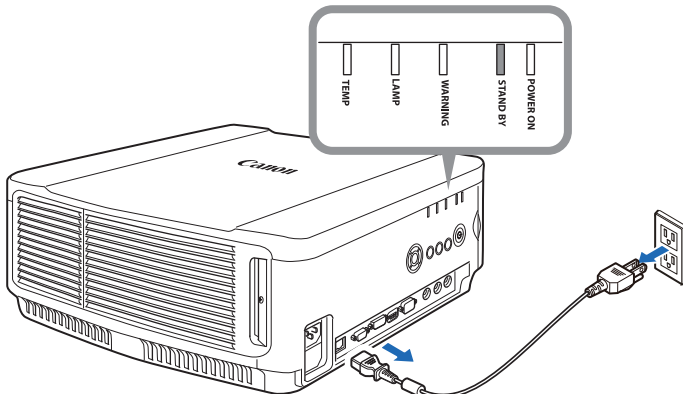

Useful Functions Available During a Presentation

Table of Contents

Safety Instructions

Before Use

Projecting an Image

Useful Functions Available During a Presentation

Setting Functions from Menus

Installation

Connecting to a Network

Maintenance

Appendix

Index

Operation

Installation and Maintenance

Appendix

Useful Functions Available During a Presentation

Temporarily Blacking Out an Image

BLANK





Useful when:

- You have finished the presentation.
- You want to divert attendees' attention from the screen.

Remote control



Press the ^{BLANK}  button to black out the image.

Press the ^{BLANK}  button again to show the image.

- You can set the screen state while blacking out the image on the menu. (P84)
- The lamp remains illuminated while the image is blacked out.

Freezing the Picture

FREEZE



Useful when:

- You want to perform a computer operation which is irrelevant to the proceedings of the presentation.
- You want to stop a moving image.

Remote control

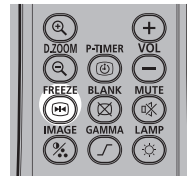

Press the ^{FREEZE}  button to freeze the moving image. The projector shows the following icon.

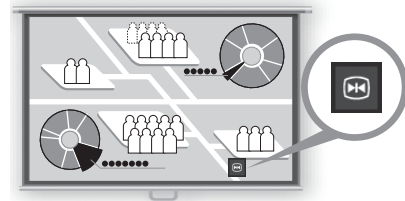

Press the ^{FREEZE}  button again to cancel the FREEZE function.

- It is also cancelled when the input signal is terminated.

Adjusting the Volume



Useful when:



- You want to adjust the volume level of the projector or external speakers.

Remote control

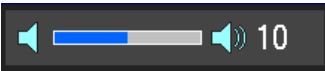

Press the  button. The following screen appears.



- You can also adjust the volume level with the  /  buttons of the projector.
- Adjust the volume or mute setting on the computer if the volume level is too low.
- You can also adjust the volume level of the speakers connected via the audio output terminal.

Muting the Sound

MUTE



Useful when:

- You want to temporarily mute unnecessary sound.
- You want to immediately mute the sound.

Remote control

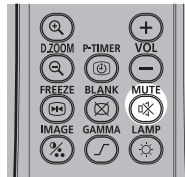

Press the  button to mute the sound. The projector shows the following icon.

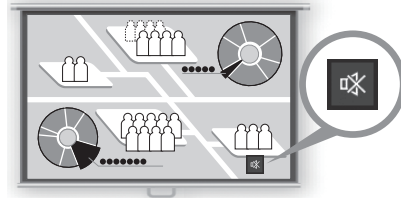

Press the  button again to cancel the mute function.

- You can also mute the sound of the speakers connected via the audio output terminal.

Useful Functions Available During a Presentation

Zooming an Image



D.ZOOM





Useful when:

- Zooming in on an object such as a small graph during a presentation (up to 12x).
- Focusing on the current subject.

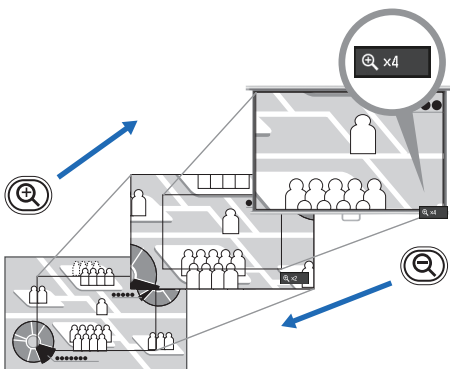
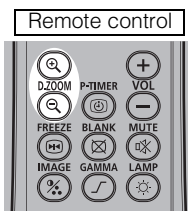
Press the  button. A part of the image is enlarged each time the button is pressed.



- The magnification appears on the screen.

You can move the enlarged area by using the , ,  /  buttons.

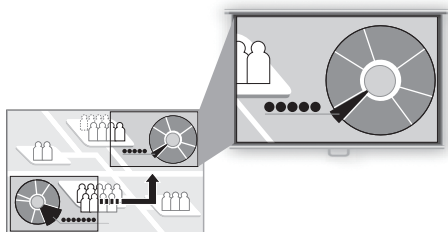
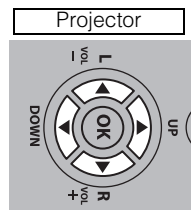
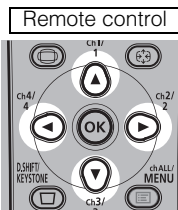

You can restore the original size of the image by pressing the  button.

Showing the Elapsed Time

P-TIMER



Useful when:

- You want to manage the timing of the presentation.

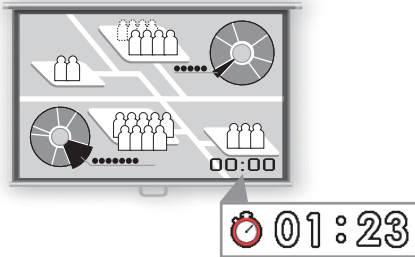



Press the ^{P-TIMER}  button to start counting.

- The elapsed time is displayed on the lower right corner of the screen.
- Time is counted up to 59:59. The timer then returns to 00:00.

Remote control



Press the ^{P-TIMER}  button again to stop the timer.

- Press the ^{P-TIMER}  button while the timer is stopped. The timer disappears from the screen. Then press the ^{P-TIMER}  button to start counting from 00:00.

Setting Functions from Menu

Table of Contents

Safety Instructions

Before Use

Projecting an Image

Useful Functions Available
During a Presentation

Setting Functions from Menu

Installation

Connecting to a Network

Maintenance

Appendix

Index

Operation

Installation and Maintenance

Appendix

How to Use Menu

Use the menu to set the operation of the projector in detail.

■ Menu Configuration

The menu screen is divided into 5 tabs as shown below.

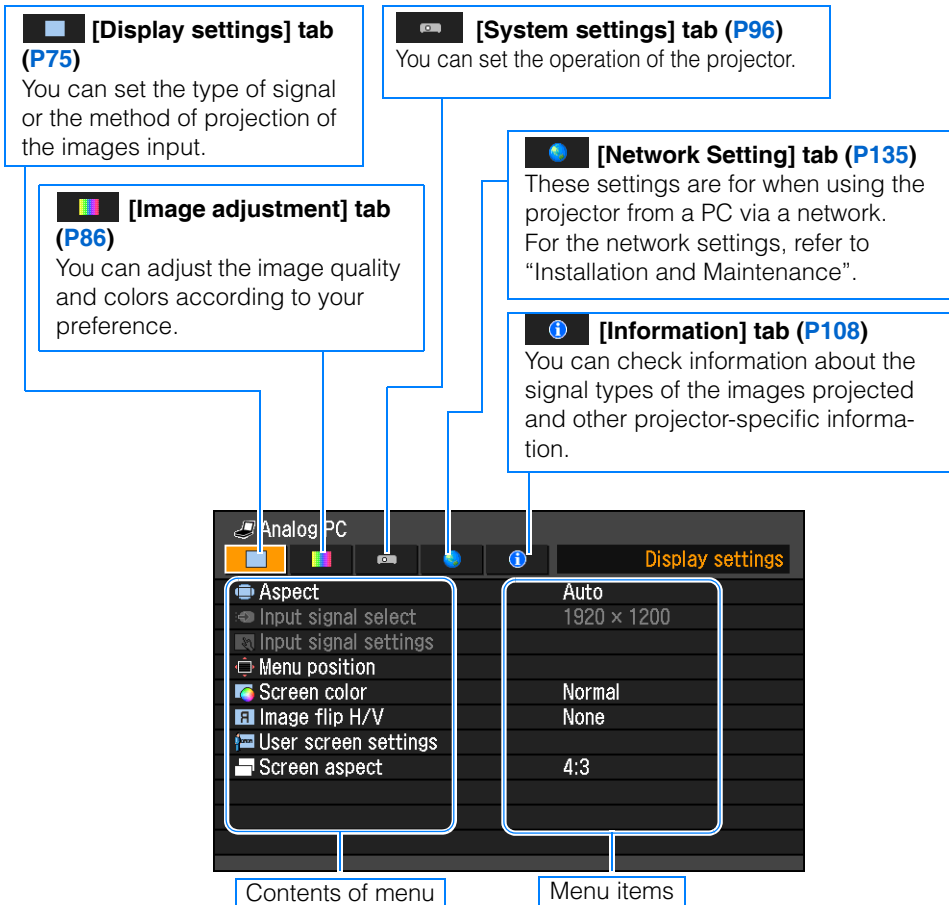

Input Signal Types for which a Menu Item is Displayed

Different menu items are displayed for different input signal types.

In the following explanation of each menu item, the input signal type for which the menu item is displayed is indicated as follows:

- Input signal for which the menu item is displayed
- Input signal for which the menu item is not displayed

- | | |
|--------------|-------------|
| ○ HDMI | — Component |
| — Digital PC | — Analog PC |

Basic Operation of Menu

1 Press the [MENU] button to display the menu window.

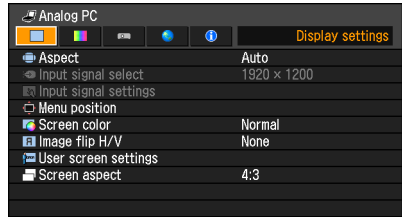
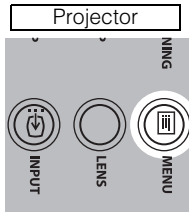
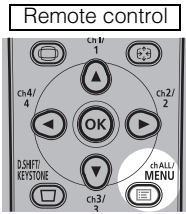

2 Use the [◀] / [▶] buttons to select a tab.

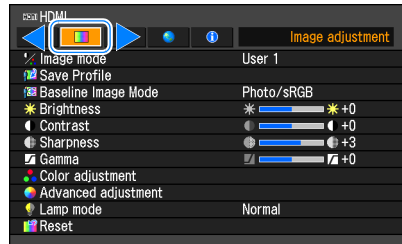
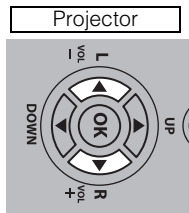
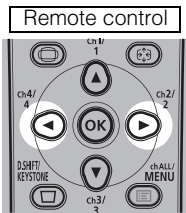

- If the tab position is not highlighted in orange, use the [▲] / [▼] buttons to move the highlight to the top.

3 Use the [▲] / [▼] buttons to select an item.

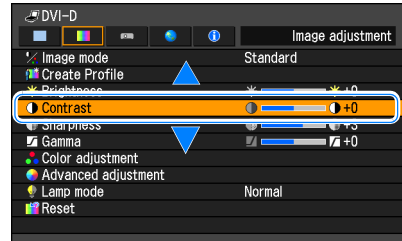
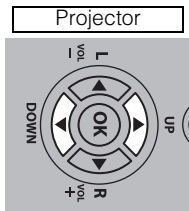
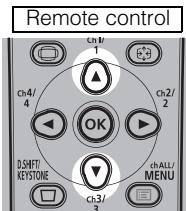

How to Use Menu

4 Select contents.

How to select the contents varies depending on the item.

Selecting from a list Example: Aspect

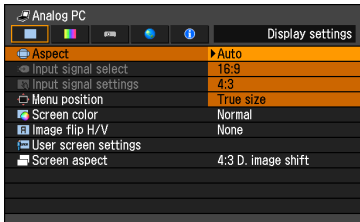

1. Press the **OK** button or **[▶]** button to display a list of the contents.
2. Use the **[▲]** / **[▼]** buttons to select the desired contents.
3. When you found the contents you desired, press the **OK** button or **[▶]**.

Adjusting with the **[◀]** / **[▶]** buttons Example: Contrast

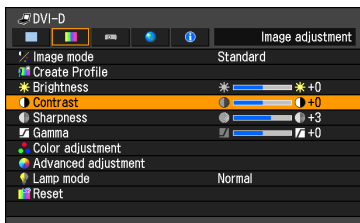

Use the **[◀]** / **[▶]** buttons to adjust the setting.

Selecting from a different screen (1) Example: Menu position

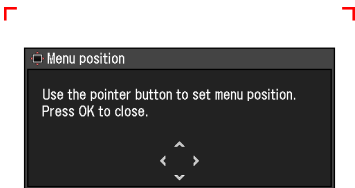

1. Press the **OK** button to display a different screen.
2. Then follow the instruction on the screen.

Selecting from a different screen (2) Example: Tracking

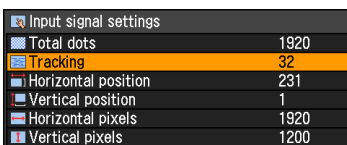

1. Press the **OK** button to display a different screen.
2. Use the **[▲]** / **[▼]** buttons to select the setting, then use the **[◀]** / **[▶]** buttons to select the value.
3. When you have completed the settings, press the **OK** button.

5 Pressing the MENU button causes the menu screen to disappear.

Setting Display Status

Selecting an Image Projection Mode

[Aspect]

- HDMI Component
 Digital PC Analog PC

You can select a projection mode corresponding to the aspect ratio of the image. (P54)

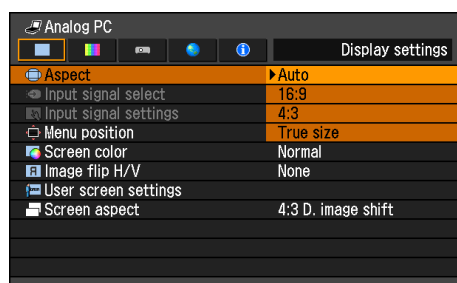

- Different contents are displayed for different screen aspects or input signal types.
- The **ASPECT** button on the remote control can also be used to select the Aspect settings.

Auto	An image is projected at the aspect ratio of the input signal. Select this mode for normal image projection.
Full	The image is projected using an input signal aspect ratio of 16:10. Select this to project computer screen images having an aspect ratio of 16:10 (WUXGA, WSXGA+, WXGA+ and WXGA (1280 x 800)) fully on the screen.
16:9	The image is projected using an input signal aspect ratio of 16:9. Select this if an image of 16:9 aspect ratio cannot be correctly projected in [Auto] mode.
4:3	The image is projected using an input signal aspect ratio of 4:3. Select this if an image of 4:3 aspect ratio cannot be correctly projected in [Auto] mode.
Zoom	An image with a 4:3 aspect ratio is projected in the center of the screen enlarged in 16:9 aspect ratio, with the upper and lower portion of the image cut off. Select this when projecting visual software that has an aspect ratio of 4:3 and black bars at the top and bottom of the image. <ul style="list-style-type: none">• This mode is available when you select [16:10], [16:9] or [16:9 D. image shift] for [Screen aspect] and select [HDMI (480p, 576p)] or [Component (480p, 480i, 576p, 576i)].
True size	The image is projected with the original resolution of the input signal. Select this to clearly project a computer screen image that has a resolution of WUXGA or lower. <ul style="list-style-type: none">• This mode is available when you select [Analog PC] or [Digital PC] for the input signal.• This mode is also available when you select [HDMI (480p, 576p, 720p, 1080i, 1080p)] and [Component (480p, 576p, 720p, 1080i, 1080p)].

Press the **OK** button to accept your setting and then press the **MENU** button.

Setting Display Status

Selecting an Input Signal Type (Analog PC)

[Input signal select]

- HDMI
- Component
- Digital PC
- Analog PC

You can select a suitable resolution if auto PC adjustment function (P49) cannot project the correct image from a computer.

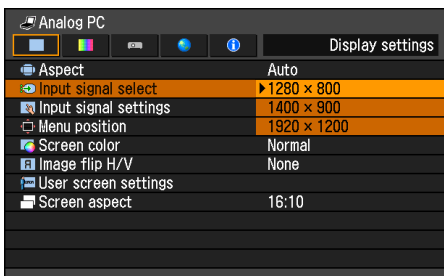

Press the **OK** button to accept your setting and then press the **MENU** button.

Select an input signal corresponding to the resolution of the computer.

- For the signal types supported by the projector, see the table on page 173.

Selecting an Input Signal Type (Component)

[Input signal select]

- HDMI
- Component
- Digital PC
- Analog PC

You can select the proper component signal type if the video image from AV equipment is not projected correctly.

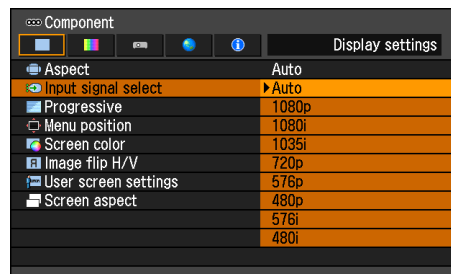

Press the **OK** button to accept your setting and then press the **MENU** button.

- [Auto] is the factory default.
- Refer to the User's Manual of the AV equipment connected to the projector to confirm the component signal type.

Adjust Input Signal (Analog PC) Total dots

[Input signal settings] - [Total dots]

- HDMI
- Component
- Digital PC
- Analog PC

You can adjust the total number of dots in the horizontal direction.

Adjust it when stripes are displayed on the screen.

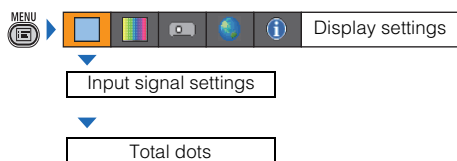

Input signal settings	
Total dots	1920
Tracking	32
Horizontal position	231
Vertical position	1
Horizontal pixels	1920
Vertical pixels	1200

Use [**◀**] / [**▶**] to select a value. When you have completed the adjustment, press the **MENU** button.

- Perform this adjustment if the [AUTO PC] function (P49) cannot adjust the projected image correctly.

Adjust Input Signal (Analog PC) Tracking

[Input signal settings] - [Tracking]

- HDMI
- Component
- Digital PC
- Analog PC

You can fine-tune the timing for generating an image from the image signal.

Adjusts the tracking when the image distorts or flickers.

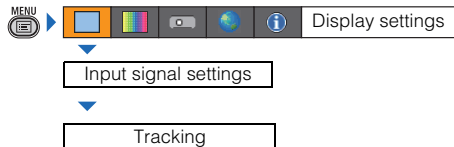

Input signal settings	
Total dots	1920
Tracking	32
Horizontal position	231
Vertical position	1
Horizontal pixels	1920
Vertical pixels	1200

Use [**◀**] / [**▶**] to select a value. When you have completed the adjustment, press the **MENU** button.

- Perform this adjustment if the [AUTO PC] function (P49) cannot adjust the projected image correctly.

Setting Display Status

Adjust Input Signal (Analog PC) Horizontal position

[Input signal settings] - [Horizontal position]

- HDMI
- Digital PC
- Component
- Analog PC

You can adjust the horizontal position of the screen when the projected image is shifted in the horizontal direction.

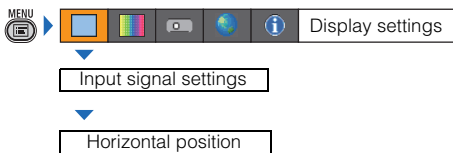

Input signal settings	
Total dots	1920
Tracking	32
Horizontal position	231
Vertical position	1
Horizontal pixels	1920
Vertical pixels	1200

Use [◀] / [▶] to select a value. As the value increases, the screen moves to the left.

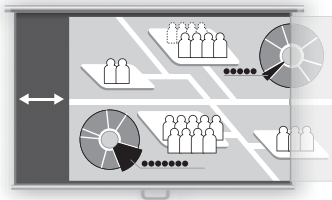

When you have completed the adjustment, press the **MENU** button.

- Perform this adjustment if the [AUTO PC] function (P49) cannot adjust the projected image correctly.

Adjust Input Signal (Analog PC) Vertical position

[Input signal settings] - [Vertical position]

- HDMI
- Digital PC
- Component
- Analog PC

You can adjust the vertical position of the screen when the projected image is shifted in the vertical direction.

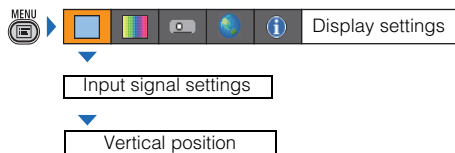

Input signal settings	
Total dots	1920
Tracking	32
Horizontal position	231
Vertical position	1
Horizontal pixels	1920
Vertical pixels	1200

Use [▲] / [▼] to select a value. As the value increases, the screen moves upward.

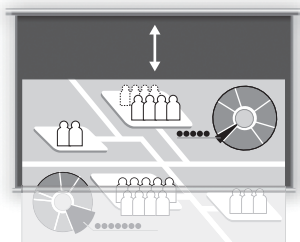

When you have completed the adjustment, press the **MENU** button.

- Perform this adjustment if the [AUTO PC] function (P49) cannot adjust the projected image correctly.

Adjust Input Signal (Analog PC) Horizontal pixels

[Input signal settings] - [Horizontal pixels]

- HDMI
- Component
- Digital PC
- Analog PC

You can adjust the number of the pixels in the horizontal direction if the length of the screen is too long or too short in the horizontal direction.

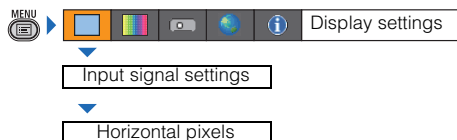

Input signal settings	
Total dots	1920
Tracking	32
Horizontal position	231
Vertical position	1
Horizontal pixels	1920
Vertical pixels	1200

Use [◀] / [▶] to select a value.

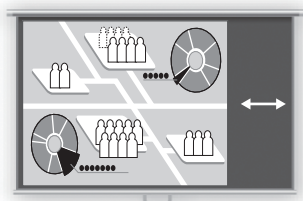

When you have completed the adjustment, press the **MENU** button.

- Perform this adjustment if the [AUTO PC] function (P49) cannot adjust the projected image correctly.

Adjust Input Signal (Analog PC) Vertical pixels

[Input signal settings] - [Vertical pixels]

- HDMI
- Component
- Digital PC
- Analog PC

You can adjust the number of the pixels in the vertical direction if the length of the screen is too long or too short in the vertical direction.

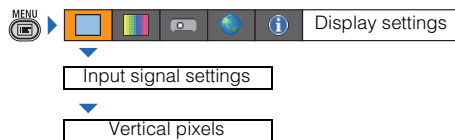

Input signal settings	
Total dots	1920
Tracking	32
Horizontal position	231
Vertical position	1
Horizontal pixels	1920
Vertical pixels	1200

Use [◀] / [▶] to select a value.

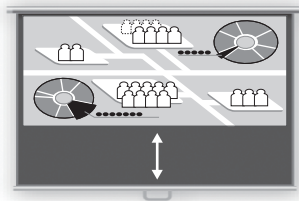

When you have completed the adjustment, press the **MENU** button.

- Perform this adjustment if the [AUTO PC] function (P49) cannot adjust the projected image correctly.

Setting Display Status

Selecting HDMI Input Level

[HDMI input level]

- HDMI — Component
- Digital PC — Analog PC

You can select this as required when you project visual software with an HDMI signal.

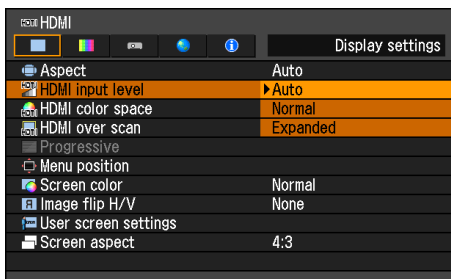

Press the **OK** button to accept your setting and then press the **MENU** button.

- [Auto] is the factory default.
- You can select this only when the type of signal sent from AV equipment is RGB.
- The signal level is selected automatically in [Auto] mode. (Some AV equipment may not support this.)
- If the HDMI output of your AV equipment allows switching between [Normal] and [Expanded], we recommend you to set [Expanded]. The contrast of images will be improved and dark scenes will be rendered more realistically. In this case, select [Auto] or [Expanded] for the HDMI input level. For more detailed information, refer to the User's Manual of the AV equipment connected to the projector.

HDMI color format

[HDMI color space]

- HDMI — Component
- Digital PC — Analog PC

Select the color space for the HDMI signal.

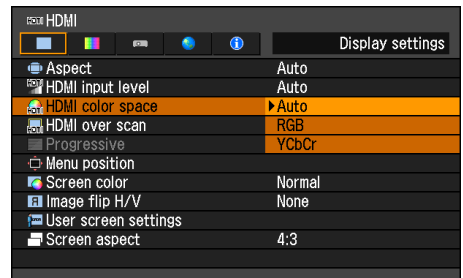

-
- | | |
|-------------|--|
| Auto | Select the optimal color format for the input HDMI signal. |
|-------------|--|
-
- | | |
|------------|---|
| RGB | Forces the projector to handle the input signal as an RGB signal. |
|------------|---|
-
- | | |
|--------------|---|
| YCbCr | Forces the projector to handle the input signal as a color difference signal. |
|--------------|---|
-

Press the **OK** button to accept your setting and then press the **MENU** button.

- [Auto] is the factory default.

Select HDMI Over Scan

[HDMI over scan]

- HDMI — Component
- Digital PC — Analog PC

You can select this as required when you project visual software using an HDMI signal.

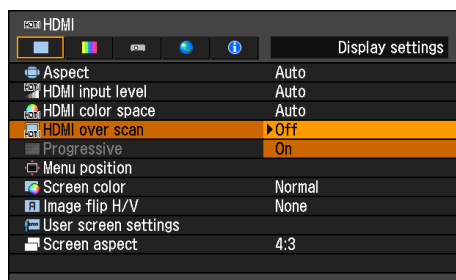

Off The entire input signal (100%) is projected.
The images projected may be smaller than the full projection screen.

On Images are projected with distortion at the peripheral section of images trimmed off. (The central 95% of the images are projected.)
Part of the peripheral sections of images may be cut out depending on the resolution of the signal. In such a case, select [Off].

Press the **OK** button to accept your setting and then press the **MENU** button.

- The factory defaults settings are [On] when [HDMI In] is set for [Auto] and [Off] when it is set for [Computer].

Performing Progressive Processing

[Progressive]

- HDMI Component
- Digital PC — Analog PC

You can select this as required when the images have low resolution.

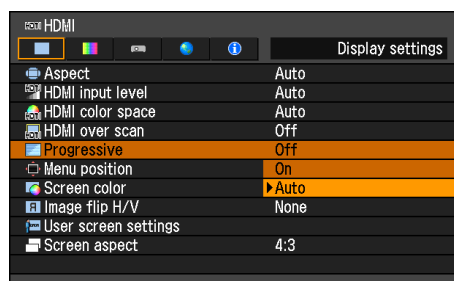

Off Do not perform progressive processing.

On Performs progressive processing. This mode is available when the HDMI signal is 1080i, or Component signal is 1080i, 1035i, 576i or 480i.

Auto Performs the appropriate progressive processing according to the input signal.

Press the **OK** button to accept your setting and then press the **MENU** button.

- [Auto] is the factory default.
- This can be set only when the [HDMI In] is [Computer] and the input signal is 1080i, 1035i, 576i or 480i.
- Select [Off] when flickers and horizontal lines are noticeable on a fast-moving picture.

Setting Display Status

Selecting a Menu Position

[Menu position]

- HDMI
- Component
- Digital PC
- Analog PC

You can change the position of menus displayed.

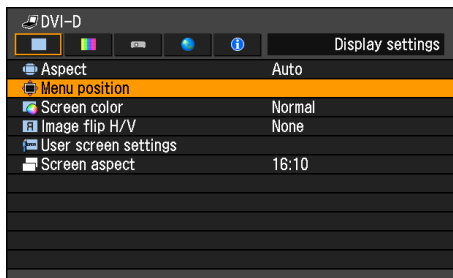

Move the menu to the desired position with the [▲], [◀], [▼] / [▶] buttons.



When the menu has been moved to the desired position, press the **OK** or **MENU** button.

Correcting the Screen Color

[Screen color]

- HDMI
- Component
- Digital PC
- Analog PC

You can adjust the color quality of the images projected corresponding to the color of the projection screen.

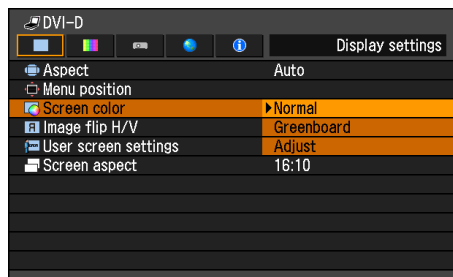

Normal Select this if a standard type of projection screen is used. The images are projected in a light quality similar to that of natural light.

Greenboard Select this if a **Greenboard** (dark green color) is used for the projection screen. The color quality similar to [Normal] is obtained on the **Greenboard**.

Adjust Select this to make detailed adjustment. The following popup screen will appear.

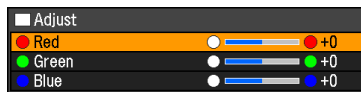

Use the [▲] / [▼] buttons to select a primary color.

[▶] makes the color selected darker.
[◀] makes the color selected lighter.

Press the **OK** button to accept your setting and then press the **MENU** button.

- [Normal] is the factory default.

Reversing Projection

[Image flip H/V]

- HDMI Component
 Digital PC Analog PC

Select this setting if you want to hang the projector from the ceiling or project an image from behind the screen.

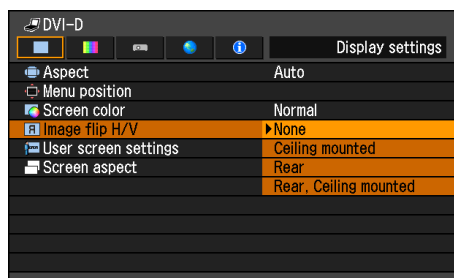

None	Select this to project an image normally.
Ceiling mounted	Select this to project an image with the projector hung from the ceiling. The projected image is inverted in both vertical and horizontal directions.
Rear	Select this to project an image from behind the screen. The projected image is inverted in the horizontal direction.
Rear, Ceiling mounted	Select this to project an image from behind the screen with the projector hung from the ceiling. The projected image is inverted in the vertical direction.

Press the **OK** button to accept your setting and then press the **MENU** button.

- [None] is the factory default.

Normal projection (none)

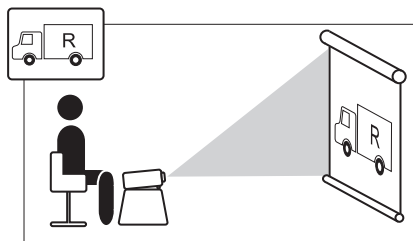

Ceiling mounted projection

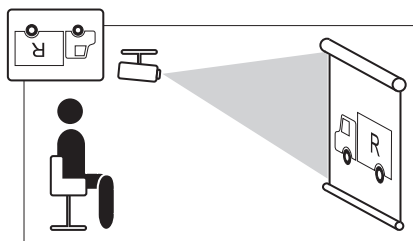

Rear projection

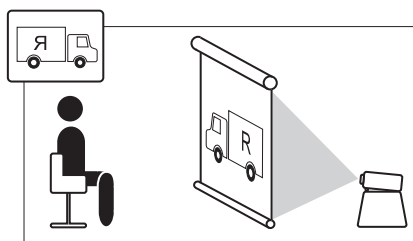

Rear ceiling mounted projection

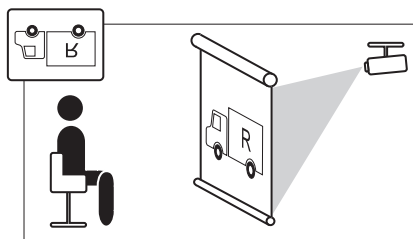

- To hang the projector from the ceiling, use the optional bracket. Contact a Canon dealer where you purchased the projector for more detailed information.
- If you flip the image, the keystone distortion adjustment will be reset.

Setting Display Status

No Signal Screen

[User screen settings] - [No signal screen]

- | | |
|----------------------------------|---------------------------------|
| <input type="radio"/> HDMI | <input type="radio"/> Component |
| <input type="radio"/> Digital PC | <input type="radio"/> Analog PC |

You can display either a black or blue screen when there is no input signal.

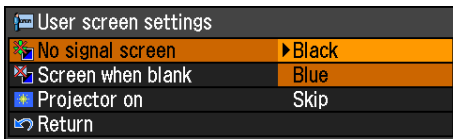
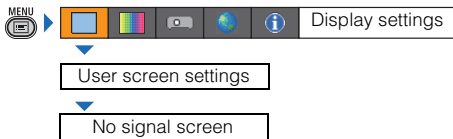

Black	The screen is all black.
-------	--------------------------

Blue	The screen is all blue.
------	-------------------------

Press the **OK** button to accept your setting and then press the **MENU** button.

- [Blue] is the factory default.

Screen When Blank

[User screen settings] - [Screen when blank]

- | | |
|----------------------------------|---------------------------------|
| <input type="radio"/> HDMI | <input type="radio"/> Component |
| <input type="radio"/> Digital PC | <input type="radio"/> Analog PC |

You can display a black or blue screen and temporarily blank out the projected image by pressing the **BLANK** button on the remote control.

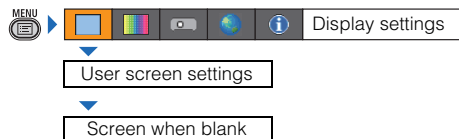

Black	The screen is all black.
-------	--------------------------

Blue	The screen is all blue.
------	-------------------------

Press the **OK** button to accept your setting and then press the **MENU** button.

- [Black] is the factory default.

Selecting a Logo at Startup

[User screen settings] - [Projector on]

- HDMI Component
 Digital PC Analog PC

You can display a specified logo on the screen from the moment the projector is turned on to the moment it is ready for projection.



Skip	Projects an input signal immediately after turning on the projector.
Canon logo	Displays the Canon logo that was registered in advance at the factory.

Press the **OK** button to accept your setting and then press the **MENU** button.

- [Canon logo] is the factory default.

Selecting Aspect Ratio of Screen

[Screen aspect]

- HDMI Component
 Digital PC Analog PC

Select according to the aspect ratio of the projection screen. (P50)



16:10	Select this when you use a screen with an aspect ratio of 16:10.
16:9	Select this when you use a screen with an aspect ratio of 16:9.
4:3	Select this when you use a screen with an aspect ratio of 4:3.
16:9 D. image shift	Select this when you use a screen with an aspect ratio of 16:9. You can move the screen upward or downward with the D.SHIFT/KEYSTONE button.
4:3 D. image shift	Select this when you use a screen with an aspect ratio of 4:3. You can move the screen to the left or right with the D.SHIFT/KEYSTONE button.

Press the **OK** button to accept your setting and then press the **MENU** button.

- [16:10] is the factory default.
- If you select [16:9 D. image shift] or [4:3 D. image shift], the keystone correction will be canceled. For more details, refer to page 51.
- [Auto] may be automatically selected for the aspect depending on the screen aspect setting.

Selecting an Image Quality

Image adjustment

[Image mode]

- HDMI
- Component
- Digital PC
- Analog PC

You can select an image mode suitable for the projected image.

You can also select it with the **IMAGE** button on the remote control. (P63)

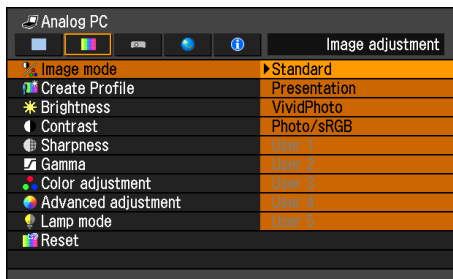

Standard This image mode emphasizes white tones and projects an image that is close to the original in quality. It is suited to project computer screens or visual software (moving pictures) in a bright room.

Presentation This image mode is suitable for text-based images such as those used in a presentation in a dimly lit room.

Dynamic Suitable for viewing visual software (moving pictures) in a slightly brighter room.

VividPhoto Select for an image where color saturation is prioritized. Suitable for viewing in a slightly darker room.

Photo/sRGB This mode conforms to sRGB standards. It is suitable for projecting pictures images taken with an sRGB-compatible digital camera.

Video Suitable for viewing video taken with a video camera in a slightly darker room.

Cinema Select for image quality that is suitable for ordinary visual software (moving pictures). This mode allows you to enjoy a Cinema-like ambience when using the projector in a dimly lit room.

User 1 - 5 Up to 5 user-selected combinations of image quality settings can be stored in the memory. (P87) Stored settings can be selected as an image mode.

Press the **OK** button to accept your setting and then press the **MENU** button.

- [Standard] is the factory default.
- You can adjust the image quality by adjusting the following items in each image mode: [Brightness], [Contrast], [Sharpness], [Gamma], [Color adjustment], [Advanced adjustment] and [Lamp mode]
- The adjustment you have made is stored as each combination of input signals and an image mode.
- The display brightness varies depending on the image mode setting.
- When a user memory that was saved in image mode is selected, [Baseline Image Mode] appears in the menu. This indicates the image mode that was the base when the user memory was saved.

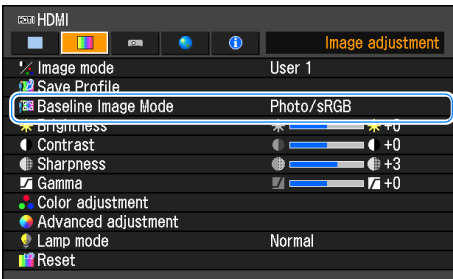

Saving the Desired Image Quality

[Create Profile]

- | | |
|----------------------------------|---------------------------------|
| <input type="radio"/> HDMI | <input type="radio"/> Component |
| <input type="radio"/> Digital PC | <input type="radio"/> Analog PC |

Up to 5 combinations of image quality settings can be stored. The stored image quality can be selected as an image mode.

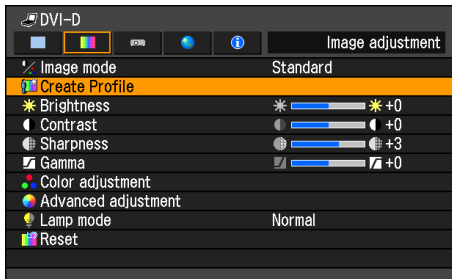

Use the [▲] / [▼] buttons and select the save destination. (Saved memories are indicated by checkmarks.)

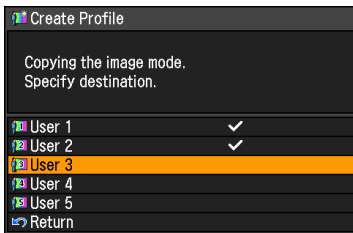

When the desired save destination is selected, press the **OK** button.

- The saved settings consist of the brightness, contract, sharpness, gamma, color adjustment, advanced adjustment, and lamp mode.
- The number of displayed user memories is 5, however it is possible to save different settings for when the connected equipment is a computer (ANALOG PC, DIGITAL PC or HDMI (when [HDMI In] is [Computer]) and when AV equipment is connected (COMPONENT, HDMI (when [HDMI In] is [Auto])). As a result, it is possible to save up to 10 settings.
- The image mode name which was the basis for the settings change is also saved in the user memory. When a user memory is selected as the image mode, the image mode that was the base for that user memory is displayed in the menu as [Baseline Image Mode].

Selecting an Image Quality

Adjusting the Brightness

[Brightness]

- HDMI
- Component
- Digital PC
- Analog PC

You can adjust the brightness of images.

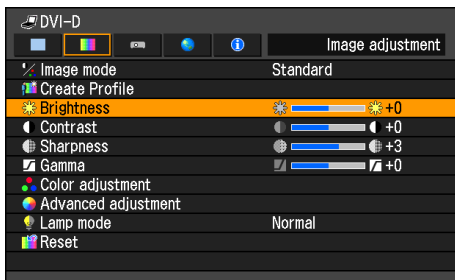

[▶] Increases the brightness of an image.

[◀] Decreases the brightness of an image.

When you have completed the adjustment, press the **MENU** button.

- The adjustment you have made is stored as adjusted values for the input signals and image mode of the current projection.

Adjusting the Contrast

[Contrast]

- HDMI
- Component
- Digital PC
- Analog PC

You can adjust the contrast of images.

If you want to make it more or less vivid, adjust the difference in tone between the lightest and darkest portions of the image.

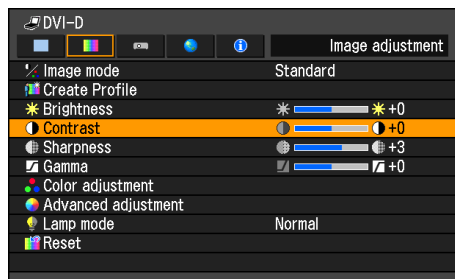

[▶] Increases the contrast of an image. This emphasizes the darker and brighter parts of the image on the projected image.

[◀] Decreases the contrast of an image. The image becomes less vivid.

When you have completed the adjustment, press the **MENU** button.

- The adjustment you have made is stored as adjusted values for the input signals and image mode of the current projection.

Adjusting the Sharpness

[Sharpness]

- HDMI Component
 Digital PC Analog PC

You can adjust the sharpness of images.

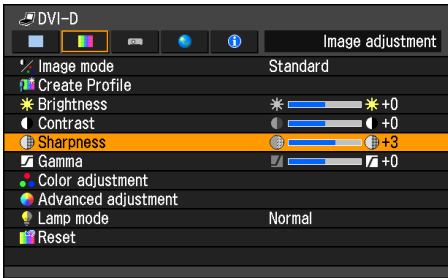

Increases the sharpness of an image.

Decreases the sharpness of an image.

When you have completed the adjustment, press the **MENU** button.

- The adjustment you have made is stored as adjusted values for the input signals and image mode of the current projection.

Making a Gamma Correction

[Gamma]

- HDMI Component
 Digital PC Analog PC

You can correct portions of an image that are difficult to see because they are too dark or bright.

Correction can be made by using the **GAMMA** button on the remote control.

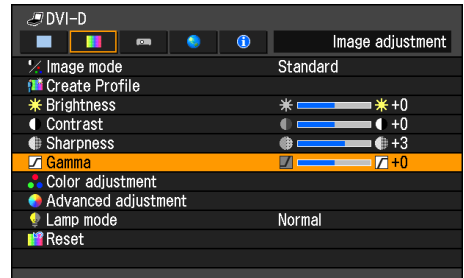

Brightens the dark portion

Darkens the bright portion

When you have completed the adjustment, press the **MENU** button.

- The adjustment you have made is stored as adjusted values for the input signals and image mode of the current projection.
- More detailed adjustment is possible by using the detailed gamma correction (P94).

Selecting an Image Quality

Adjusting Color

[Color adjustment]

- HDMI
- Component
- Digital PC
- Analog PC

You can adjust the color depth and hue of images for each primary color, red, green and blue. The color temperature can also be adjusted.

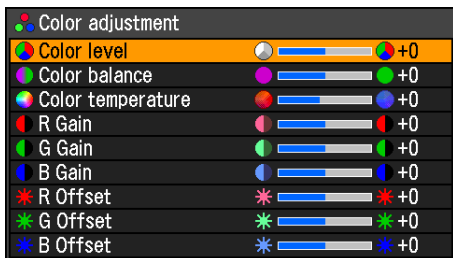

Color level	Adjusts the intensity of each color. [▶] Increases the intensity of color. [◀] Decreases the intensity of color.
Color balance	Adjusts the color balance of a reddish or greenish image. [▶] Corrects a reddish image. [◀] Corrects a greenish image.
Color temperature	Adjusts the color temperature of the image. [▶] Changes to a bluish color (cold color). [◀] Changes to a reddish color (warm color).
R/G/B Gain	Adjusts the intensity of each color. [▶] Increases the color intensity. [◀] Decreases the color intensity.
R/G/B Offset	Adjusts the color reproducibility of dark portions of each color. [▶] Increases the color reproducibility. [◀] Decreases the color reproducibility.

When you have completed the adjustment, press the **MENU** button.

- The adjustments you have made are stored as adjusted values for the input signals and image mode of the current projection.

Correcting the Image According to the Ambient Light

[Advanced adjustment] - [Ambient light]

- HDMI Component
 Digital PC Analog PC

You can correct and more effectively project an image according to the ambient light on the screen.

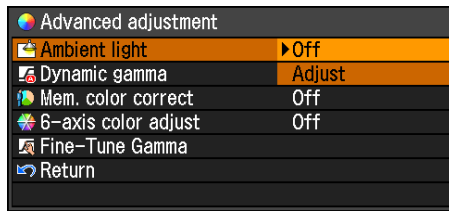
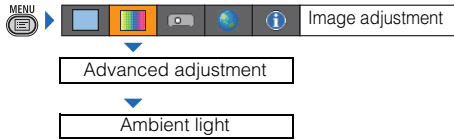

Off	Projects an image with no correction.
Adjust	You can specify the type and level (brightness) of the ambient light.



Type	Tungsten	Select this if the ambient light source is a light bulb or bulb color fluorescent.
	Fluorescent	Select this if the ambient light source is a day white fluorescent.
	Fluorescent H	Select this if the ambient light source is a day-light color fluorescent.

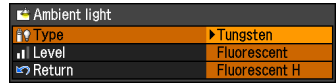

Level	L	Select this if the ambient light is low.
	M	Select this if the ambient light is normal.
	H	Select this if the ambient light is high.

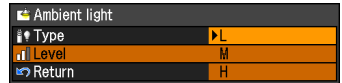

Examples of Ambient Light Settings

Level	Example Location
L	Projection room, bar
M	Photo studio, gallery
H	Conference room, lecture room

Press the **OK** button to accept your setting and then press the **MENU** button.

- [Off] is the factory default.
- [Ambient light] can be set only in the following image modes.
 - HDMI or COMPONENT: Video, Cinema, Photo/sRGB
 - DIGITAL PC, ANALOG PC: Photo/sRGB

Selecting an Image Quality

Noise reduction

[Advanced adjustment] - [Noise reduction]

- HDMI
- Component
- Digital PC
- Analog PC

You can reduce image noise.

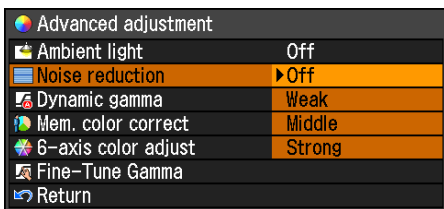
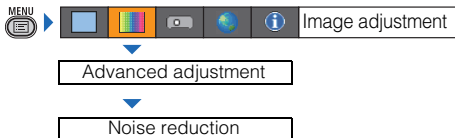

Off Disables noise reduction.

Weak
Middle
Strong Specifies the intensity of the noise reduction in three steps.

Press the **OK** button to accept your setting and then press the **MENU** button.

- [Off] is the factory default.
- Noise reduction may produce motion artifacts when projecting fast-moving images.
- Select [Weak] for fast-moving images. Select [Strong] for slow-moving images.
- The adjustment you have made is stored as adjusted values for the input signals and image mode of the current projection.
- When [HDMI In] is [Computer], this setting is not displayed.

Dynamic gamma

[Advanced adjustment] - [Dynamic gamma]

- HDMI
- Component
- Digital PC
- Analog PC

You can adjust the gradation representation of light and dark portions of an image automatically.

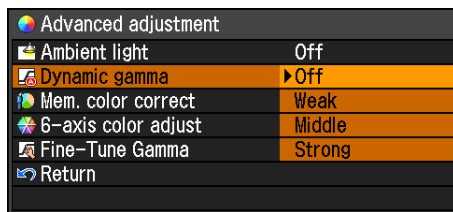

Off Dynamic gamma is disabled.

Weak
Middle
Strong Specifies the intensity of the dynamic gamma in three steps.

Press the **OK** button to accept your setting and then press the **MENU** button.

- The factory default settings are [Off] when the connected equipment is a Computer (ANALOG PC, DIGITAL PC, HDMI (when [HDMI In] is [Computer])) and [Weak] when the connected equipment is AV equipment (COMPONENT, HDMI (when [HDMI In] is [Auto])).
- The adjustment you have made is stored as adjusted values for the input signals and image mode of the current projection.

Memory Color Correction

[Advanced adjustment] - [Mem. color correct]

- HDMI
- Component
- Digital PC
- Analog PC

This function produces beautiful skin tones, blues, and other colors.

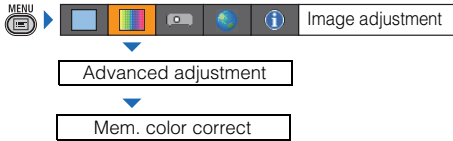

Advanced adjustment	
Ambient light	Off
Dynamic gamma	Off
Mem. color correct	Off
6-axis color adjust	L
Fine-Tune Gamma	M
Return	H

Off Disables the memory color correction function.

L
M
H Specifies the intensity of the memory color correction in three steps.

Press the **OK** button to accept your setting and then press the **MENU** button.

- [Off] is the factory default.
- The adjustment you have made is stored as adjusted values for the input signals and image mode of the current projection.

6-axis color adjust

[Advanced adjustment] - [6-axis color adjust]

- HDMI
- Component
- Digital PC
- Analog PC

You can make fine adjustments to the image colors with RGB (red, green, blue) and CMY (cyan, magenta, yellow).

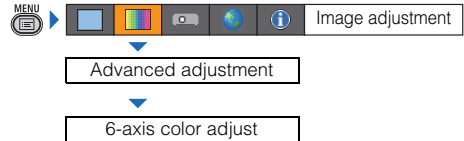

Advanced adjustment	
Ambient light	Off
Dynamic gamma	Off
Mem. color correct	Off
6-axis color adjust	Off
Fine-Tune Gamma	Adjust
Return	Reset

Off Disables 6-axis color adjustment. If you select [Adjust], the previous setting of 6-axis color adjustment becomes active again.

Adjust Enables 6-axis color adjustment.

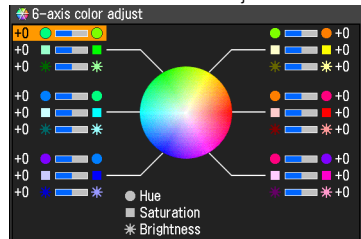

Use the **▲** / **▼** buttons to select [○ Hue], [□ Saturation], or [* Brightness], then adjust them with the **◀** / **▶** buttons.

When color adjustments are completed, press the **OK** button.

Reset Returns all adjustment values to zero.

When you have completed the adjustment, press the **MENU** button.

- [Off] is the factory default.
- The adjustments you have made are stored as adjusted values for the input signals and image mode of the current projection.

Detailed Gamma Correction

[Advanced adjustment] - [Fine-Tune Gamma]

- | | |
|----------------------------------|---------------------------------|
| <input type="radio"/> HDMI | <input type="radio"/> Component |
| <input type="radio"/> Digital PC | <input type="radio"/> Analog PC |

The four gamma curves (white, red, green, blue) can be adjusted. When the white curve is adjusted, the adjustment is also applied to the other three colors. This function allows more fine-tuned adjustment than [Gamma]. When either of these two functions is adjusted, the settings of the other are overwritten.

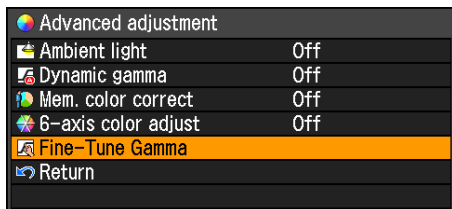
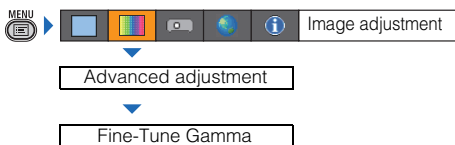

Select [Fine-Tune Gamma] then press the OK button. The following [Fine-Tune Gamma] screen for confirmation appears.

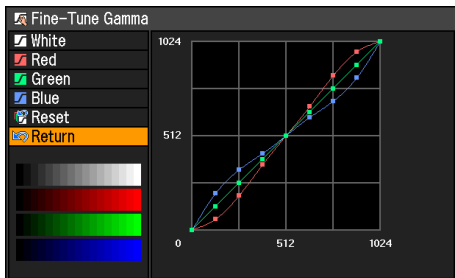

Use the [▲] / [▼] buttons to select the color, then press the OK button. Next use the [◀] / [▶] buttons to select a point on the gamma curve, and use the [▲] / [▼]

buttons to adjust the position of the point. When you have completed the adjustment, press the OK button.

- The adjustments you have made are stored as adjusted values for the input signals and image mode of the current projection.
- For the details of gamma correction, refer to page 89.

Reducing the Lamp Brightness

[Lamp mode]

- HDMI Component
 Digital PC Analog PC

Reducing the lamp brightness reduces power consumption and cooling fan noise. You can also enable or disable this mode with the LAMP button on the remote control.

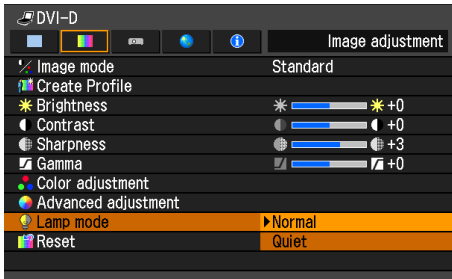
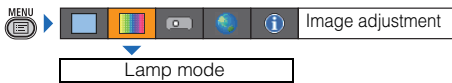

Normal	Projects an image at the normal brightness level.
Quiet	Reduces the lamp brightness and cooling fan noise.

Press the **OK** button to accept your setting and then press the **MENU** button.

- [Normal] is the factory default.
- The adjustment you have made is stored as adjusted values for the input signals and image mode of the current projection.

Resetting the Image Settings

[Reset]

- HDMI Component
 Digital PC Analog PC

You can reset the current image settings to the default settings. If reset is performed when user setting 1 - 5 is selected for [Image mode], the settings are returned to the settings that were saved in [User setting 1 - 5].

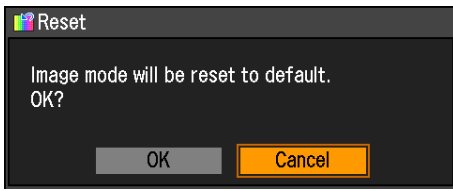
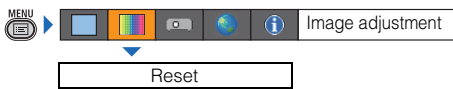

OK	Resets the image settings.
Cancel	Cancels resetting of the image settings.

Press the **OK** button to accept your setting and then press the **MENU** button.

- Only the setting for the combination of input signal and image mode for the current projection is reset.

Setting Various Functions

Selecting the Power Management Mode

[Power management mode]

- HDMI
- Component
- Digital PC
- Analog PC

You can turn off the lamp or projector automatically in order to save power when the projector is not in use.

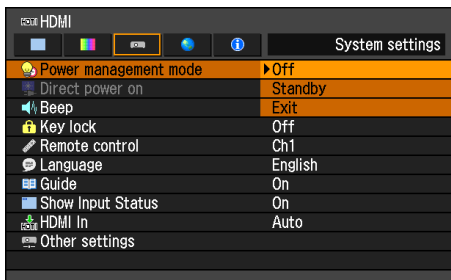

Off	Disables the power management mode.
Standby	If no input signal is received for 30 seconds, the projector enters the standby mode, turning off the lamp five minutes after start of countdown. If it receives an input signal or is operated during this period of 30 seconds, it resumes projection.
Exit	If no input signal is received for 30 seconds, it displays the countdown and turns off the projector after 5 minutes.

Press the **OK** button to accept your setting and then press the **MENU** button.

- [Off] is the factory default.
- During standby mode, the [POWER ON] indicator and [STAND BY] indicator flash alternately.
- You cannot enable the [Direct power on] function (see the next item), if you select [Off].

Skip the POWER Button Operation

[Direct power on]

- HDMI
- Component
- Digital PC
- Analog PC

You can turn on the projector by connecting the power cable without pressing the POWER button.

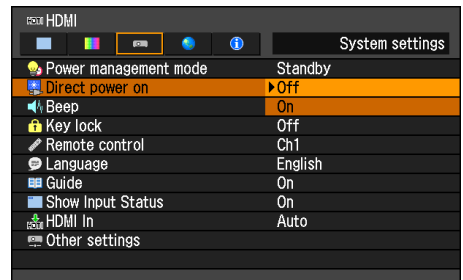

Off	You need to press the POWER button to turn on the projector.
On	You can turn on the projector by connecting the power cable only.

Press the **OK** button to accept your setting and then press the **MENU** button.

- [Off] is the factory default.



- Before setting the direct power-on to [On], be sure to set the [Power management mode] to [Standby] or [Exit].
- After turning off the projector, wait at least 5 minutes before turning it on again. It may shorten the lamp life if you turn on the projector immediately after turning it off.

Enabling/Disabling the Beep

[Beep]

- HDMI Component
 Digital PC Analog PC

You can select whether a beep sounds or not when you operate the projector.

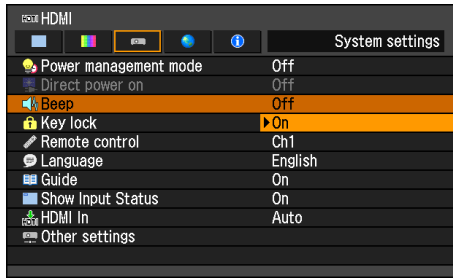

Off Disables the beep.

On Enables the beep.

Press the **OK** button to accept your setting and then press the **MENU** button.

- [On] is the factory default.
- The beep will not sound if you mute the projector sound with the **MUTE** button on the remote control.

Prohibiting Operation of the Projector

[Key lock]

- HDMI Component
 Digital PC Analog PC

You can lock the projector to prevent its operation from either the side control or remote control.

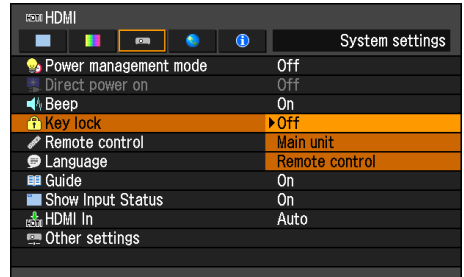
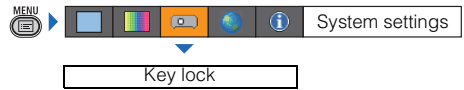

Off Disables the key lock.

Main unit Lock the operation from the main unit.
Use the remote control.

Remote control Lock the operation from the remote control.
Use the main unit.

Press the **OK** button to accept your setting and then press the **MENU** button.

- [Off] is the factory default.



The key lock function becomes effective from the moment the **OK** button is pressed after selecting [Main unit] or [Remote control]. Be sure to press the **OK** button on the side control or remote control which is not locked.

To Unlock Key Lock Function

Turn off the projector and unplug the power plug. Hold down the **OK** button on the side control and connect the power plug. Keep holding down the button until a beep sounds. The key lock is unlocked.

Setting up the Remote Control Channel

[Remote control]

- | | |
|----------------------------------|---------------------------------|
| <input type="radio"/> HDMI | <input type="radio"/> Component |
| <input type="radio"/> Digital PC | <input type="radio"/> Analog PC |

When using multiple projectors at the same time (maximum 4), you can assign a different channel to each remote control so that each operates independently.

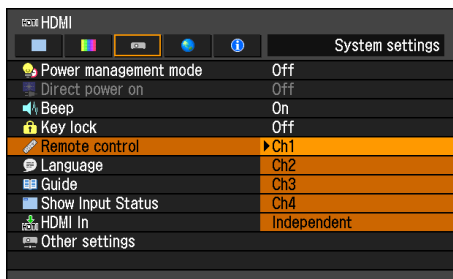

- Ch1 Select the remote control channel to use with this projector.
- Ch2
- Ch3
- Ch4

Independent Remote controls set to any channel can be used.

Press the **OK** button to accept your setting and then press the **MENU** button.

- The factory default is [Independent] for both projector and remote control.
- After changing the channel on the menu, be sure to change the channel of the remote control too.

Selecting a Channel on the Remote control

You can change the channel on the remote control as follows.

- | | |
|--------------------|---|
| Ch1 | Press and hold the OK button and [▲] button at the same time for 3 seconds. |
| Ch2 | Press and hold the OK button and [▶] button at the same time for 3 seconds. |
| Ch3 | Press and hold the OK button and [▼] button at the same time for 3 seconds. |
| Ch4 | Press and hold the OK button and [◀] button at the same time for 3 seconds. |
| Independent | Press and hold the OK button and MENU button at the same time for 3 seconds. |

Selecting a Display Language

[Language]

- HDMI Component
 Digital PC Analog PC

You can select the language in which the menus are displayed.



Language		
English	Русский	Čeština
Deutsch	Nederlands	Dansk
Français	Suomi	إنجليزي
Italiano	Norsk	中文简体
Español	Türkçe	中文繁體
Português	Polski	한국어
Svenska	Magyar	日本語

Use the [▲], [▼], [▶] / [◀] buttons to select the menu language, then press the OK button.

English	English
German	Deutsch
French	Français
Italian	Italiano
Spanish	Español
Portuguese	Português
Swedish	Svenska
Russian	Русский
Dutch	Nederlands
Finnish	Suomi
Norwegian	Norsk
Turkish	Türkçe
Polish	Polski
Hungarian	Magyar
Czech	Čeština
Danish	Dansk
Arabic	إنجليزي
Chinese (Simplified)	中文简体
Chinese (Traditional)	中文繁體
Korean	한국어
Japanese	日本語

When the setting is completed, press the MENU button.

Showing/Hiding the Guide Screen

[Guide]

- HDMI Component
 Digital PC Analog PC

You can select whether to show or hide the guide screen which explains operations.



System settings	
Power management mode	Off
Direct power on	Off
Beep	On
Key lock	Off
Remote control	Ch1
Language	English
Guide	Off
Show Input Status	▶ On
HDMI In	Auto
Other settings	

Off Hides the guide screen.

On Shows the guide screen.

Press the OK button to accept your setting and then press the MENU button.

- [On] is the factory default.
- The guide screen is shown at the following times.
 - Power is turned off by pressing the POWER button. (P64)
 - No input signal can be detected. (P44)
 - An invalid button is pressed in the [BLANK], [FREEZE] or [D.ZOOM] mode. (P66, P68)

Setting Various Functions

Showing/Hiding the Input Status

[Show Input Status]

- HDMI
- Component
- Digital PC
- Analog PC

Select whether or not to show the input signal status on the screen when there is no signal or a signal has been set.

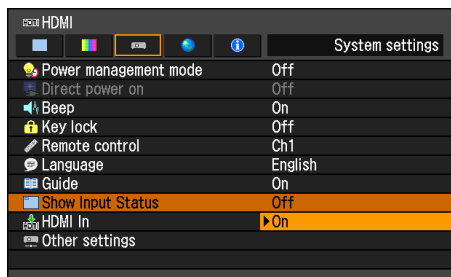
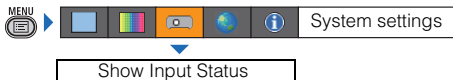

- Off The input status is not displayed.
- On The input status is displayed.

Press the **OK** button to accept your setting and then press the **MENU** button.

- [On] is the factory default.

Selecting the HDMI Input

[HDMI In]

- HDMI
- Component
- Digital PC
- Analog PC

Set the type of equipment which is connected to the HDMI port.

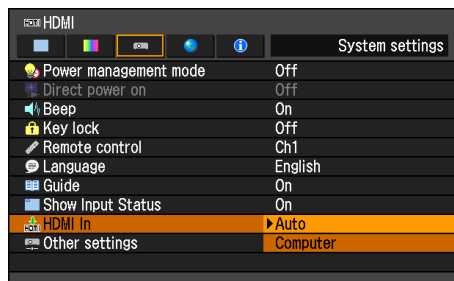

- Auto** Select when AV equipment will be connected. Image processing, menu displays, and other elements are adjusted for video equipment.

- Computer** Select when a **computer** will be connected. Image processing, menu displays, and other elements are adjusted for a **computer**.

Press the **OK** button to accept your setting and then press the **MENU** button.

Setting a Password

[Other settings] - [Password settings]

- | | |
|----------------------------------|---------------------------------|
| <input type="radio"/> HDMI | <input type="radio"/> Component |
| <input type="radio"/> Digital PC | <input type="radio"/> Analog PC |

Disables the projector unless the correct password is entered.

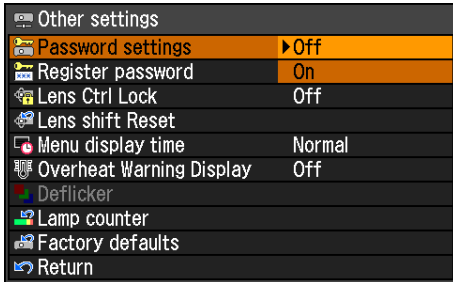
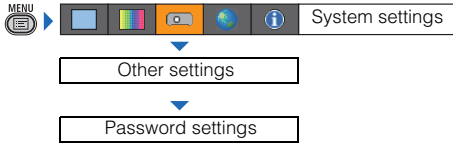

Off	The projector can be used even if no password is entered.
On	The projector cannot be used unless you enter your password.

Press the **OK** button to accept your setting and then press the **MENU** button.

- [Off] is the factory default.
- You cannot set [On] unless you have completed [Register password].

Once you set a password, the password entry screen appears at power-on.

Enter a 4-digit password consisting of a combination of the [▲], [▼], [◀] / [▶] buttons.

If the password is valid, the projection starts. If you enter a wrong password three times, the power will be turned off.

- The power is also turned off if no password is input for 3 minutes.

To Cancel the Password

Turn off the projector and unplug the power plug.
 Hold down the **MENU** button on the side control and connect the power plug. Make sure to keep holding down the **MENU** button until a beep sounds. When the beep sounds, the password is canceled. (The entered password is also reset.)
 To forcibly cancel the password from the remote control, in standby state press the **MENU** button 3 times, then press the **POWER** button.

Setting Various Functions

Registering a Password

[Other settings] - [Register password]

- HDMI
- Component
- Digital PC
- Analog PC

You can register a password for starting projection.

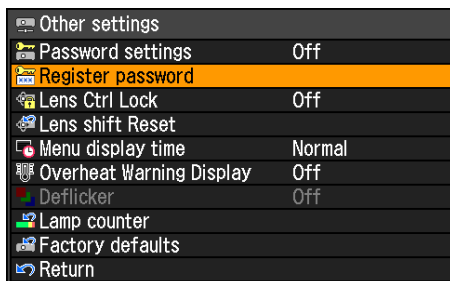
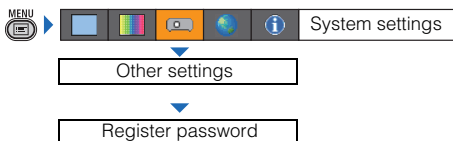

Press the **OK** button after selecting [Register password], and the following screen for registering a password appears.

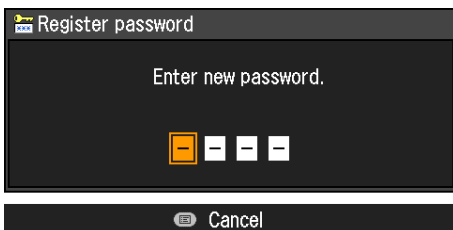

Enter a 4-digit password consisting of a combination of the [▲], [▶], [▼] / [◀] buttons. (Examples: [▲] [▲] [▲] [▲], [◀] [◀] [◀] [◀], [▲] [▼] [◀] [▶])

The 4-digit password is entered from the left to right digits. When the final digit is entered, the password is automatically registered.

- Press the **MENU** button to abort the registration.

Prohibiting Operation of the Lens

[Other settings] - [Lens Ctrl Lock]

- HDMI
- Component
- Digital PC
- Analog PC

You can lock lens-related button operations.

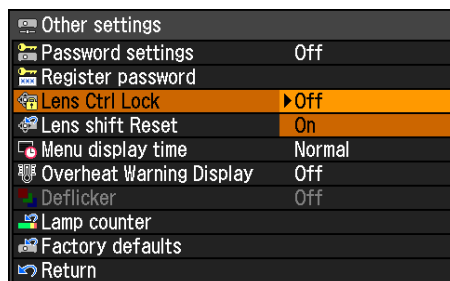
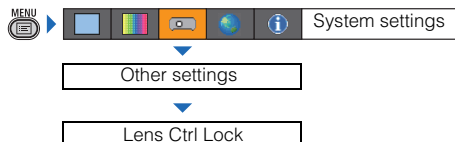

-
- | | |
|------------|---|
| Off | Focus, zoom, lens shift, and other lens-related operations are permitted. |
| <hr/> | |
| On | Focus, zoom, lens shift, and other lens-related operations are locked. |
-

Press the **OK** button to accept your setting and then press the **MENU** button.

- [Off] is the factory default.

Lens Shift Reset

[Other settings] - [Lens shift Reset]

- HDMI
- Component
- Digital PC
- Analog PC

Resets the lens shift (P58) setting to the standard position.

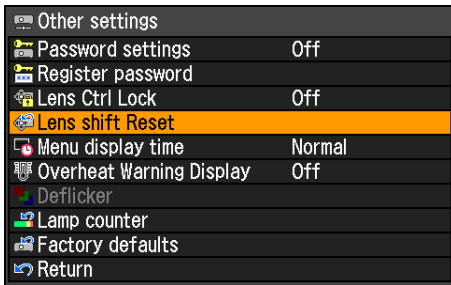
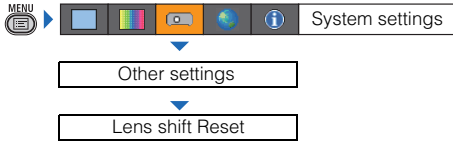

Select [Lens shift Reset] and press the **OK** button. The following screen for confirmation appears.

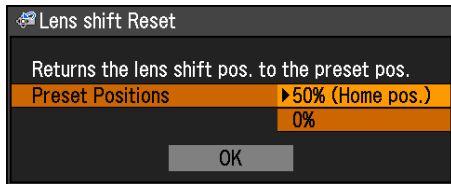

Use the **[▲]** / **[▼]** buttons to select the standard position, and then select **OK**.

- The standard position varies depending on the type of lens unit used. For details, refer to "Resetting the Position". (P59)
- The position which was adjusted by lens shift does not change when the power is turned off.

Extending the Menu Display Time

[Other settings] - [Menu display time]

- HDMI
- Component
- Digital PC
- Analog PC

You can extend the menu display time from the normal setting of 30 seconds to 3 minutes.

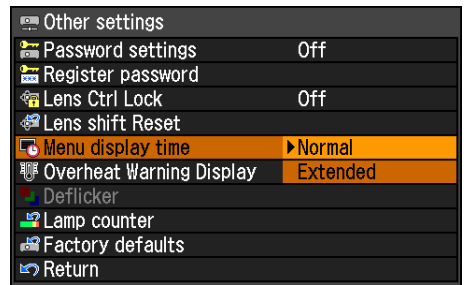
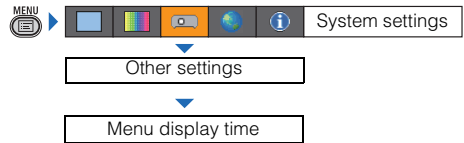

Normal The menu is displayed for 30 seconds.
Extended The menu is displayed for 3 minutes.

Press the **OK** button to accept your setting and then press the **MENU** button.

- [Normal] is the factory default.
- The following display and operation are also changed.

Item	[Normal]	[Extended]
The display time of the following screens		
-Input (P47)		
-Zoom adjustment (P56)		
-Focus adjustment (P57)		
-Keystone adjustment (P59)		
-Keystone reset (P61)		
-D.image shift adjustment (P52, P53)	4 to 10 seconds	3 minutes
-D.image shift reset (P53)		
-Aspect (P55)		
-Image mode (P62)		
-Volume adjustment (P67)		
-Lamp mode (P95)		
-Lens shift (P58)		
-Lens shift reset (P103)		
Press-and-hold operation of pointer buttons other than for [Zoom adjustment], [Focus adjustment], and [Lens shift]	Enabled	Disabled
Press-and-hold operation of VOL button		
Press-and-hold operation of the D.ZOOM button		

Setting Various Functions

Showing/Hiding the High Temperature Warning Icon

[Other settings] - [Overheat Warning Display]

- | | |
|----------------------------------|---------------------------------|
| <input type="radio"/> HDMI | <input type="radio"/> Component |
| <input type="radio"/> Digital PC | <input type="radio"/> Analog PC |

You can select whether or not to display the [High temperature warning] icon when the temperature inside the projector has increased and is approaching the overheat temperature.

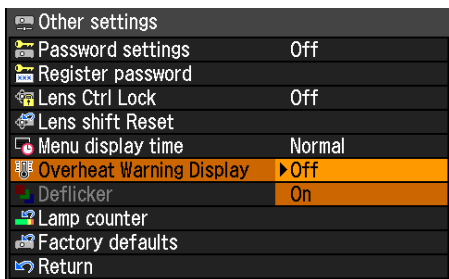
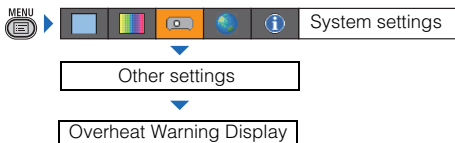

- | | |
|------------|---|
| Off | The [High temperature warning] icon is not displayed. |
| On | The [High temperature warning] icon is displayed. |

Press the **OK** button to accept your setting and then press the **MENU** button. When [On] is set, the [High temperature warning] icon shown below will be displayed when the temperature inside the projector is abnormally high.

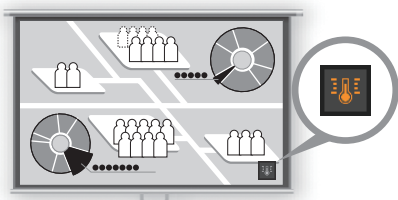

- [Off] is the factory default.

Reducing Flickering

[Other settings] - [Deflicker]

- | | |
|----------------------------------|---------------------------------|
| <input type="radio"/> HDMI | <input type="radio"/> Component |
| <input type="radio"/> Digital PC | <input type="radio"/> Analog PC |

This function adjusts the image display in order to reduce flickering in the projected image.

- Deflicker can only be used when the lamp has been on for approximately 30 minutes or longer.
- Be aware that deflicker may be unable to eliminate flickering in some cases.

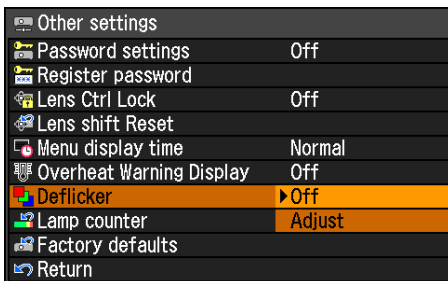
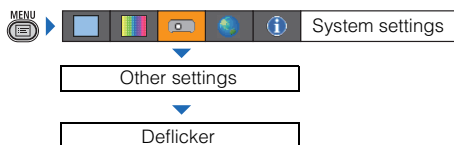

- | | |
|------------|--|
| Off | Deflicker adjustment is not performed. |
|------------|--|

Select [Deflicker] to adjust. The following screen appears.

Adjust

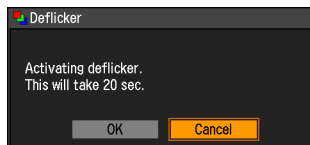

- | | |
|---------------|-----------------------------|
| OK | Deflicker is performed. |
| Cancel | Deflicker is not performed. |

- When deflicker is performed, the image adjustment screen is projected for approximately 20 seconds.
- To cancel deflicker, press the **POWER** button.

Resetting the Lamp Counter

[Other settings] - [Lamp counter]

- | | |
|----------------------------------|---------------------------------|
| <input type="radio"/> HDMI | <input type="radio"/> Component |
| <input type="radio"/> Digital PC | <input type="radio"/> Analog PC |

You can reset the lamp counter that indicates the time for lamp replacement.

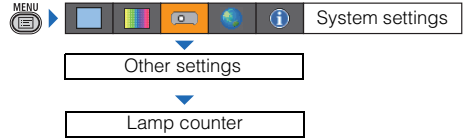

Do not reset the lamp counter except when you have replaced the lamp. Otherwise, the lamp counter cannot indicate the correct timing for replacing the lamp.

For details of lamp replacement, refer to page [159](#).

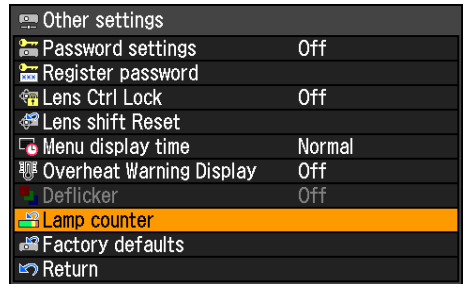

Select [Lamp counter] and press the **OK** button to display the lamp counter.

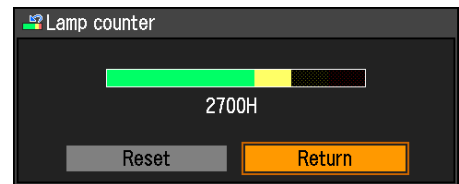

Select [Reset] and press the **OK** button.

Setting Various Functions

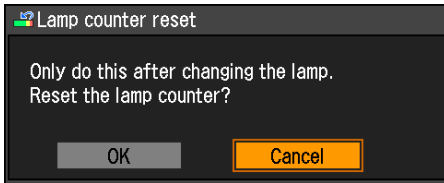

Select [OK] on the screen for confirmation and press the **OK** button to reset the lamp counter.

Press the **MENU** button.

■ About the Display of the Lamp Counter

The lamp counter displays the hours of use of the lamp in the following way.

Less than 2,700 hours

Displayed as a **green** bar.

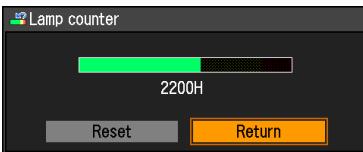

2,700 hours to less than 3,000 hours

Displayed as a **green and yellow** bar.

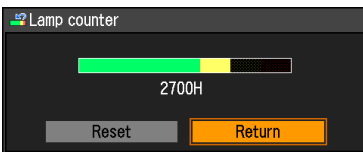

When the lamp hours are 2,700 hours to less than 3,000 hours, the message "Obtain a new lamp." appears when power is turned on.

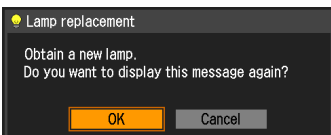

Over 3,000 hours

Displayed as a **green, yellow and red** bar.

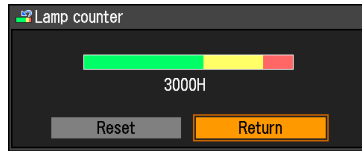

The message "Replace with the new lamp." appears when power is turned on.

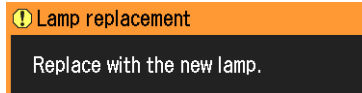

Resetting to the Default Setting

[Other settings] - [Factory defaults]

- | | |
|----------------------------------|---------------------------------|
| <input type="radio"/> HDMI | <input type="radio"/> Component |
| <input type="radio"/> Digital PC | <input type="radio"/> Analog PC |

You can reset the menu item settings and restore the system settings to the factory defaults.

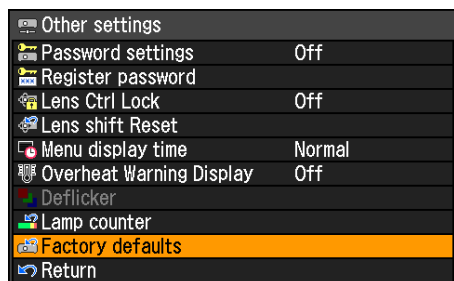
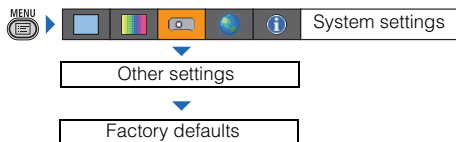

Select [Factory defaults] and press the **OK** button. The following screen for confirmation appears.

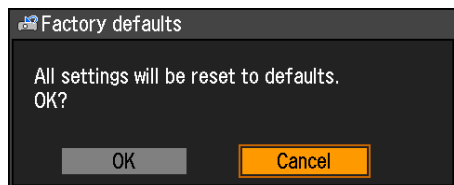

OK	Settings are reset to default.
Cancel	Settings are not reset to default.

Press the **OK** button to accept your setting and then press the **MENU** button.

- This function does not reset the values for [Lamp counter], [Language], [Remote control], [Input signal], [Network Setting], [Filter counter], [Focus position], [Zoom position], and [Lens shift position].
- For factory defaults settings, refer to pages [183](#) – [185](#).
- The contents of the user memory return to the conditions at the time it was saved. ([P87](#))

Checking Projector Information

[Information]

- HDMI
- Component
- Digital PC
- Analog PC

You can confirm information about the signal types of the images projected and other projector-specific information.

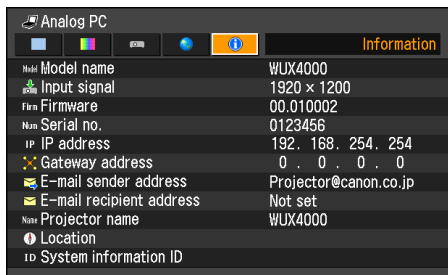

Information shown

Item	Meaning
Model name	Model name of this projector
Input signal	Details of the input signal currently selected Information such as the signal type, signal resolution, and frequency is displayed.
Firmware	Current firmware version
Serial No.	Serial number unique to this projector
IP address*	IP address of the projector (P139)
Gateway address*	IP address of the gateway device (P139)
E-mail sender address*	Sender e-mail address used for sending error mails (P146)
E-mail recipient address*	Displays [Already set] or [Not set] to show whether a recipient e-mail address has been set for receiving error mails. (P146)
Projector name*	Name which identifies this projector on the network
Location*	Location where the projector is installed
System information ID	System information. Normally this is not displayed.

* Not displayed when network functions are [Off].

MULTIMEDIA PROJECTOR
WUX4000

Installation and Maintenance

Do not attempt installation yourself. Be sure to request installation from a qualified technician or Canon dealer.



Installation

Table of Contents

Safety Instructions

Before Use

Projecting an Image

Useful Functions Available
During a Presentation

Setting Functions from Menus

Operation

Installation

Connecting to a Network

Maintenance

Installation and Maintenance

Appendix

Index

Appendix

Installation Precautions

Precautions When Carrying the Projector

Prepare the projector as described below before carrying it.



- Disconnect the cables connected to the projector. Carrying the projector with the cables attached may cause an accident.
- Retract the adjustable feet.
- When the projector is transported after the lens unit is installed, be sure that you do not grasp the lens while transporting it. Doing so may damage the projector.

Installation Precautions

Be sure to read “Safety Instructions” on page 10 – 22. Pay attention to the following when installing the projector.



- Do not strike the projector or subject it to impact. Doing so may cause a malfunction.
- Do not install the projector so that it is inclined or standing vertically. The projector may tip over, causing damage.
- Do not block the cooling fan intake or exhaust vent. If the intake or exhaust vent is blocked, heat may accumulate inside the projector, causing a malfunction.

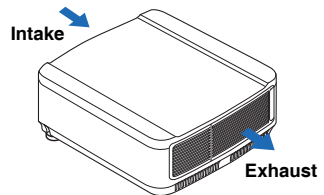

Precautions When Carrying and Transporting the Projector



- Do not reuse any packaging or shock-absorbent materials that were supplied with the projector at the time of purchase for transporting or shipping the projector. Protection of the projector cannot be guaranteed if used packaging or shock-absorbent materials are reused. Fragments from shock-absorbent material may also enter the interior of the projector which could cause a malfunction.
- When you need to transport the product, contact your Canon dealer.

■ Do Not Use in the Following Environments

- Do not install the projector in a humid or dusty location or a position where there is a lot of oily smoke or cigarette smoke. Optical parts such as the lens and mirror may be stained, resulting in poor picture quality.
- Do not install close to high-voltage power lines or power sources.
- Do not use the projector on a soft surface such as a carpet or sponge mat. Heat may accumulate inside the projector, causing a malfunction.
- Do not use the projector in a location that is subject to very high temperatures, very low temperatures, or high levels of humidity. Doing so may cause a malfunction. The temperature and humidity ranges for operation and storage are as shown below.

Operating temperature	Operating humidity	Storage temperature	Storage humidity
5°C to 35°C	Up to 85%	-30°C to 60°C	Up to 90%

■ Do Not Touch the Lens with Bare Hands

Do not touch the lens with bare hands. Doing so may adversely affect picture quality.

■ Install at a Sufficient Distance from Walls and Other Obstructions

- If the air intake or exhaust vent is blocked, heat will accumulate inside the projector, possibly resulting in a fire, shortening the projector lifetime, and causing a malfunction. Do not install in a closet, on a bookshelf, or other narrow location with poor ventilation. Install in a well ventilated location. (Install with a minimum of 50 cm (1.6') clearance on the top and sides, and 50 cm (1.6') to the rear.)

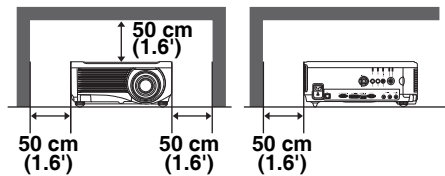
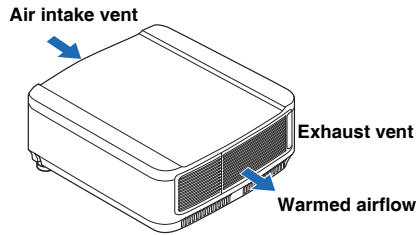

■ Be Careful of Condensation

If the temperature of the room rises suddenly, moisture in the air may condense on the projector lens and mirror, causing the image to become blurred. Wait until condensation evaporates and a normal picture is shown.

Installation Precautions

■ When using mounted on the ceiling

When the projector is used mounted on the ceiling or installed in a high location, it is necessary to periodically clean the air intake and exhaust vents, and the area around the air filter. If dust accumulates in the intake or exhaust vents, cooling performance will deteriorate, causing the internal temperature to rise and possibly resulting in a malfunction or fire. Use a vacuum cleaner or similar means to remove dust from the intake vent and exhaust vent.

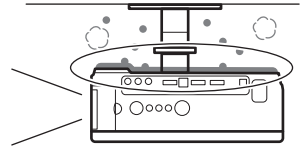

■ Install facing in the correct direction



This projector can be installed in directions of 360° *1 as shown in the illustration below. However, if projecting upward or downward, the life span of the lamp may be shortened.

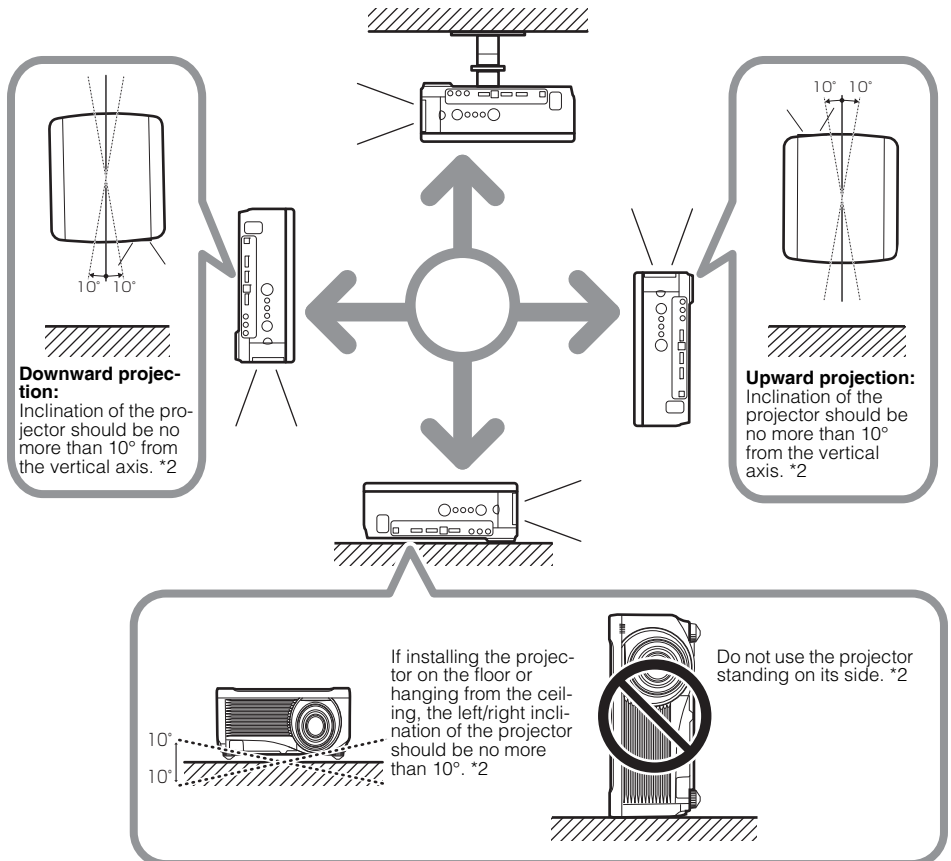

*1 There are no options for installing the projector other than the ceiling attachment. (P116, P182)

*2 This may damage the lamp.

Installation Procedure

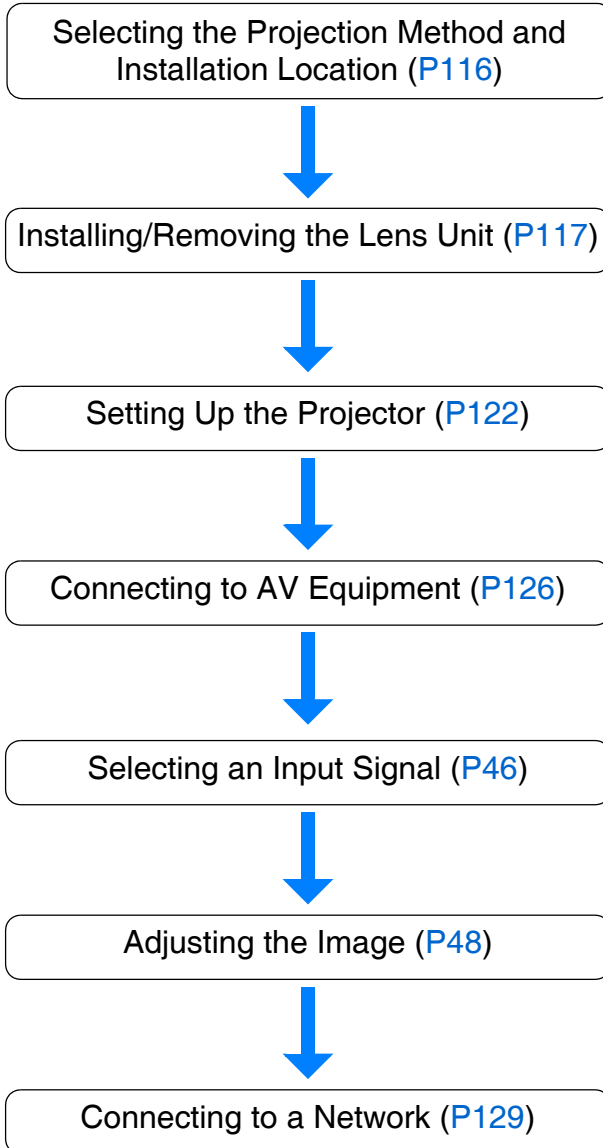

Selecting the Projection Method and Installation Location

■ Ceiling Mounting or Rear Projection

You can mount the projector on the ceiling (ceiling mounting) with it turned upside down or place it behind the screen (rear projection) if you use a translucent screen.

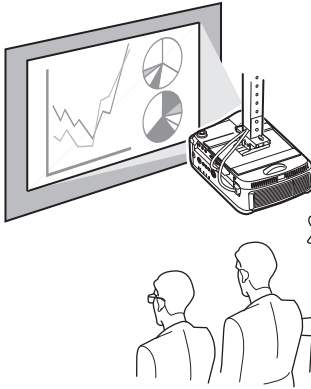

Ceiling Mounting

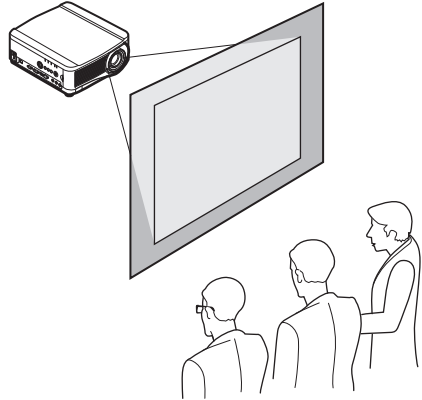

Rear Projection

Make sure to use the optional ceiling attachment. For the ceiling attachment, refer to page [182](#) “Option”.

■ Inclining the Projector Upwards When Installed on a Flat Surface

When the screen is in a higher position, point the projector up using the adjustable feet. You can incline it upwards to a maximum of 6°.

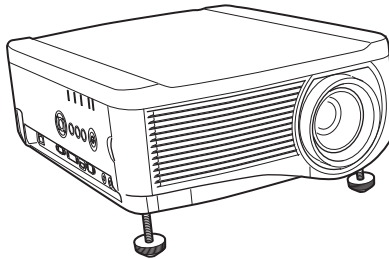

When the projector is inclined upwards, the projected image will be distorted into a trapezoid shape. This can be corrected by using the keystone correction. ([P59](#))

Installing/Removing the Lens Unit

■ Installing the Lens Unit



Before installing or removing the lens unit, be sure to disconnect the power plug or connector. Failure to do so may result in fire, electric shock, or injury.



- Before replacing the lens unit, make sure to turn off the projector, wait at least 1 hour to allow the projector to cool thoroughly. Failure to do so may result in burns or other injuries.
- Do not touch the lens when the lens is moving (the lens is shifting) to adjust the projected image after installation. There is the risk of injury.
- When hanging the projector from a ceiling, put the projector down on the floor or a workbench before attaching or replacing the lens unit. Failure to do so could result in parts falling off the projector and may cause an accident or personal injury.



Caution

- Do not attempt to install or remove the lens unit yourself. Be sure to request this service from a qualified technician or Canon dealer.
- When installing and removing the lens unit, be sure not to touch the surface of the lens with your hands or scratch it.
- Do not apply force to parts (e.g. lead wires) that are connected to the lens unit or lens motor. Doing so may cause malfunction.
- Do not replace the lens unit in a dusty location. If any dust or dirt enters the projector, this may adversely affect picture quality.
- For details about which devices the projector is compatible with, contact a Canon dealer.

- 1** Use a Phillips-head screwdriver and loosen the lamp cover screw, then open the lamp cover.

The lamp cover screw is attached to the lamp cover and designed to prevent it from falling off.

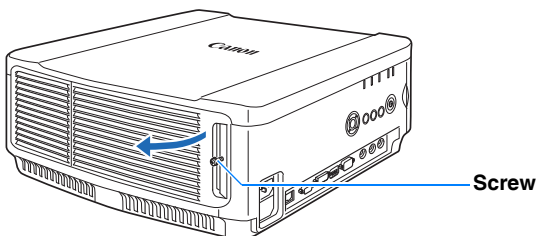

Installing/Removing the Lens Unit

- 2** Loosen the cosmetic panel screw, then slide the cosmetic panel toward the rear to remove it.
The cosmetic panel screw is attached to the cosmetic panel and designed to prevent it from falling off.

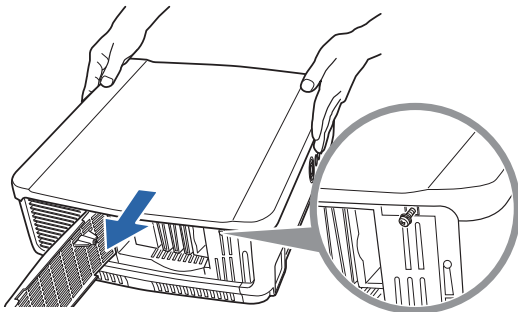

- 3** In order to prevent damage, close the lamp cover and temporarily fasten the screw.

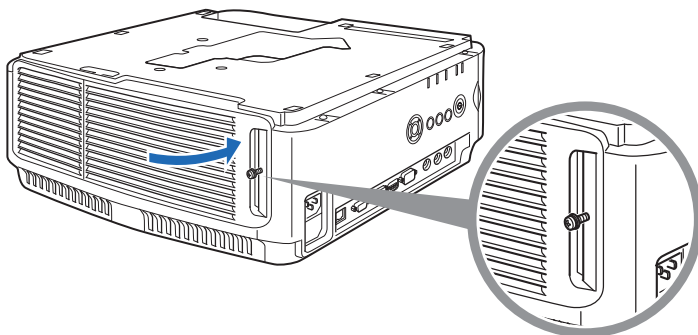

- 4** Remove the sleeve screws (2 on top and 2 on bottom).
After the 2 screws on top are removed, turn the projector upside down on a flat desk or similar location and remove the 2 screws from the bottom.

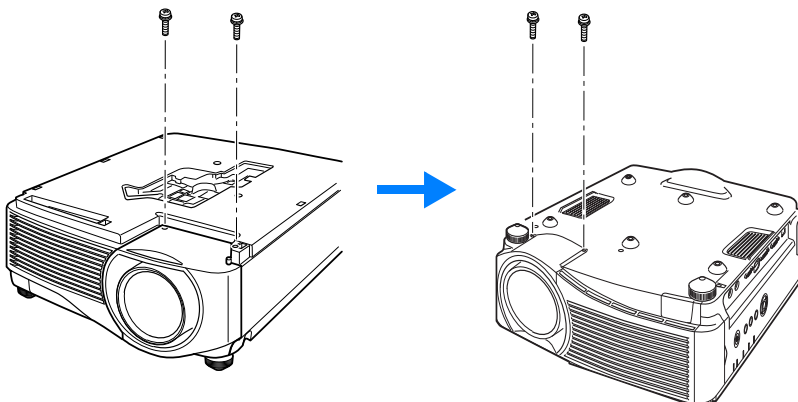

- 5** Then turn the projector back over and remove the sleeve.

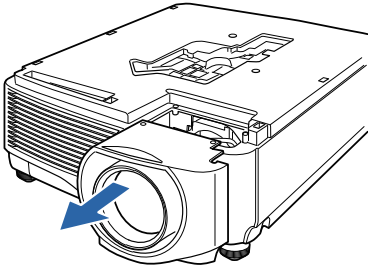

- 6** Referring the following illustration, insert the lens connector of the lens unit into the front right side of the projector slowly until it contacts the end. At this time, pull out the lens cable shown in the illustration and fix it.

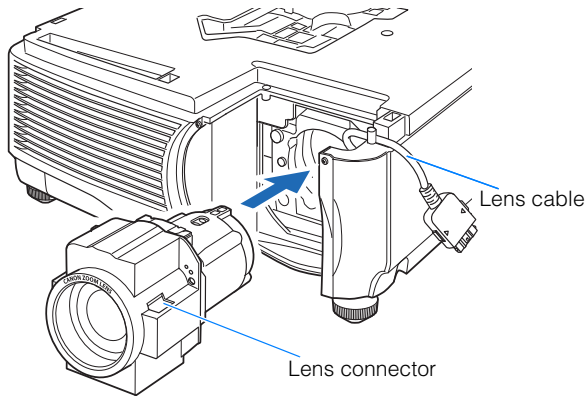

- 7** Tighten the 4 screws to fasten the lens unit in place.
The 4 lens unit screws are attached to the lens unit and cannot be removed.

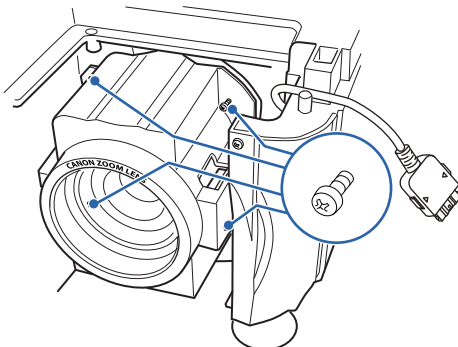

Installing/Removing the Lens Unit

- 8** Insert the projector lens cable into the connector until a click sound is heard.

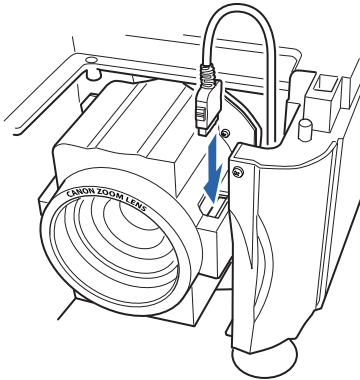

- 9** Return the sleeve, cosmetic panel, and lamp cover to their original conditions.



When the power is first turned on after the lens unit is replaced, the initialization operation will be performed. Approximately 1 minute are required before the projector starts.



Caution

When installing and removing the lens unit, be sure to fix the lens cable as shown in the illustration. When inserting the lens unit, it is possible to damage the lens cable between the lens unit and projector.

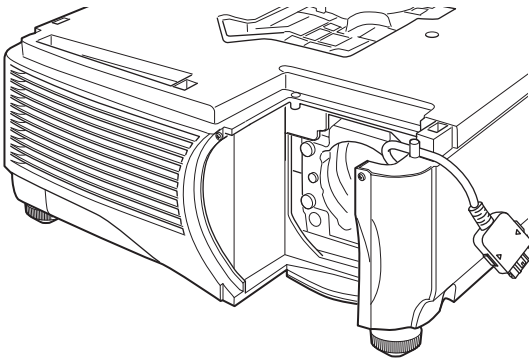

■ Removing the Lens Unit

1 Perform steps 1 to 5 of “Installing the Lens Unit” (P117 – P119) and remove the sleeve.

2 Disconnect the lens cable from the lens connector.

! When pulling out (disconnecting) the lens cable, press the buttons on both sides of the lens cable connector while pulling out the cable.

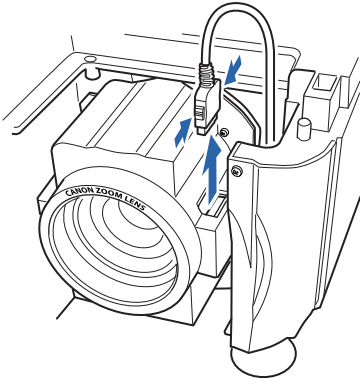

3 Fix the lens cable as shown in the illustration and loosen the 4 screws to remove the lens unit.

The 4 lens unit screws are attached to the lens unit and cannot be removed.

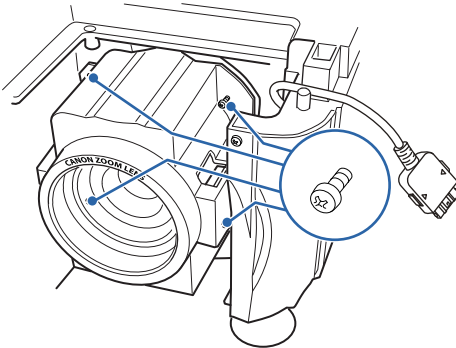

Setting Up the Projector

■ Positioning the Projector in Front of the Screen

Place the projector in front of the screen.



- Be sure to place the projector parallel to the screen to ensure distortion-free projection.
- The screen must not be exposed to direct sunlight or light from lighting equipment. In a bright room, it is recommended that lights be turned off, curtains be drawn, and other steps taken to make the screen easier to see.

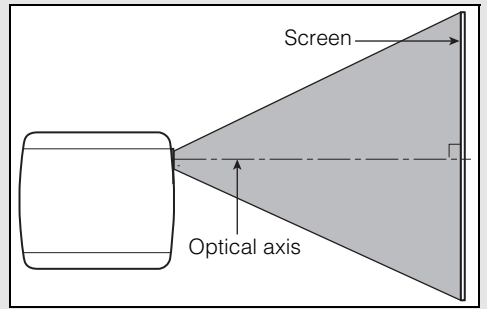

■ Relationship Between Image Size and Projecting Distance

The projected image size is determined by the distance between the projector and the screen (projection distance) as well as the zoom. Refer to the table below and decide the distance between the projector and screen.

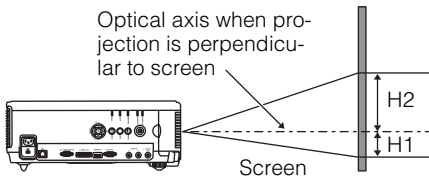
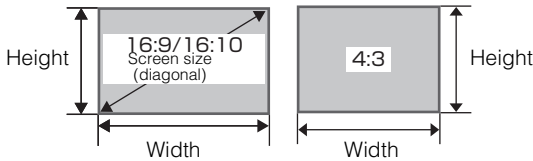

Setting Up the Projector

Lens unit	Diagonal when 16:10 (diagonal)	Image size (cm)						Projection distance		Distance from optical axis when projection is perpendicular to screen* (cm)	
		16:10		16:9		4:3		Zoom Maximum	Zoom Minimum		
		Width	Height	Width	Height	Width	Height	m (feet)	m (feet)	H1	H2
Standard Zoom Lens RS-IL01ST	40	86	54	86	48	72	54	1.3 (4.3)	1.9 (6.2)	54	0
	60	129	81	129	73	108	81	1.9 (6.2)	2.9 (9.5)	81	0
	80	172	108	172	97	144	108	2.6 (8.5)	3.9 (12.8)	108	0
	100	215	135	215	121	179	135	3.2 (10.5)	4.8 (15.7)	135	0
	150	323	202	323	182	269	202	4.8 (15.7)	7.2 (23.6)	202	0
	200	431	269	431	269	359	269	6.4 (21.0)	9.6 (31.5)	269	0
	250	538	337	538	303	449	337	8.0 (26.2)	12.1 (39.7)	337	0
	300	646	404	646	363	538	404	9.6 (31.5)	14.5 (47.6)	404	0
	350	754	471	754	424	628	471	11.3 (37.1)	16.9 (55.4)	471	0
	400	862	538	860	484	718	538	12.9 (42.3)	19.3 (63.3)	538	0
	450	969	606	969	544	808	606	14.5 (47.6)	21.7 (71.2)	606	0
	500	1077	673	1077	605	898	673	16.1 (52.8)	24.1 (79.1)	673	0
	550	1185	740	1185	666	987	740	17.7 (58.1)	26.6 (87.3)	740	0
600	1292	808	1292	726	1076	808	19.3 (63.3)	29.0 (95.1)	808	0	
Long Zoom Lens RS-IL02LZ	40	86	54	86	48	72	54	1.9 (6.2)	3.2 (10.5)	54	0
	60	129	81	129	73	108	81	2.8 (9.2)	4.8 (15.7)	81	0
	80	172	108	172	97	144	108	3.8 (12.5)	6.4 (21.0)	108	0
	100	215	135	215	121	179	135	4.7 (15.4)	8.0 (26.2)	135	0
	150	323	202	323	182	269	202	7.1 (23.3)	12.1 (39.7)	202	0
	200	431	269	431	269	359	269	9.5 (31.2)	16.1 (52.8)	269	0
	250	538	337	538	303	449	337	11.9 (39.0)	20.2 (66.3)	337	0
	300	646	404	646	363	538	404	14.2 (46.6)	24.2 (79.4)	404	0
	350	754	471	754	424	628	471	16.6 (54.5)	28.3 (92.8)	471	0
	400	862	538	860	484	718	538	19.0 (62.3)	32.3 (106.0)	538	0
	450	969	606	969	544	808	606	20.9 (68.6)	35.6 (116.8)	606	0
	500	1077	673	1077	605	898	673	23.8 (78.1)	40.4 (132.5)	673	0
	550	1185	740	1185	666	987	740	26.1 (85.6)	44.5 (146.0)	740	0
600	1292	808	1292	726	1076	808	28.5 (93.5)	48.5 (159.1)	808	0	
Short Fixed Lens RS-IL03WF	40	86	54	86	48	72	54	0.7 (2.3)		27	27
	60	129	81	129	73	108	81	1.0 (3.3)		41	41
	80	172	108	172	97	144	108	1.4 (4.6)		54	54
	100	215	135	215	121	179	135	1.7 (5.6)		68	68
	150	323	202	323	182	269	202	2.6 (8.5)		101	101
	200	431	269	431	242	359	269	3.4 (11.2)		135	135
	250	538	337	538	303	449	337	4.3 (14.1)		168	168
	300	646	404	646	363	538	404	5.2 (17.1)		202	202

* H1 and H2 are the distances when the lens shift is the default value (listed below).
 Standard Zoom Lens, Long Zoom Lens: Up/down +50%, left/right 0%
 Short Fixed Lens: Up/down/left/right 0%
 However after the lens unit is replaced, the lens shift position is unknown.

Installation and Maintenance Installation

Setting Up the Projector

■ Lens Shift Function

The projector includes a lens shift function. Operation of the buttons slides the lens up, down, left, and right, moving the image position. For the function operations, refer to “Adjusting the Image Position” (P58).

The amount of lens shift is indicated as a percentage relative to the image height and width. The amounts of lens shift for the Standard Zoom Lens and Long Zoom Lens is +55% (up), -15% (down), and $\pm 10\%$ (left/right). With the Short Fixed Lens, the amounts are $\pm 5\%$ (up/down) and $\pm 2\%$ (left/right).

The diagram below shows the maximum lens shift with the Standard Zoom Lens and Long Zoom Lens.

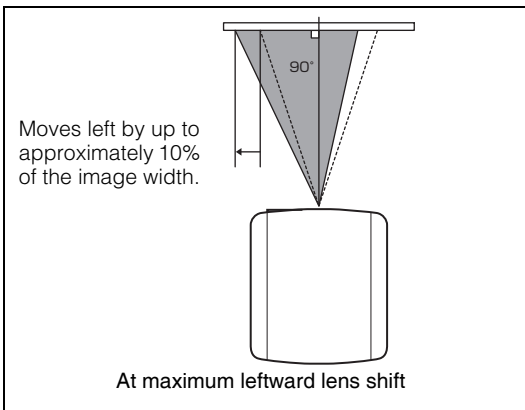
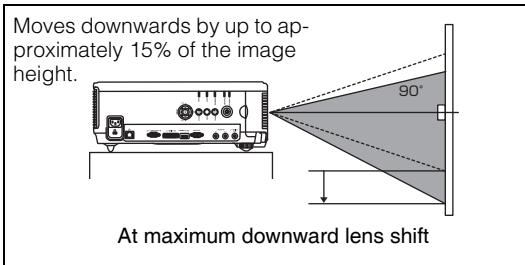
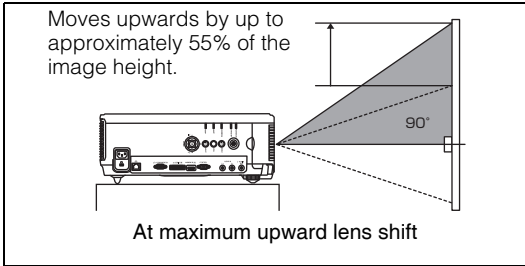

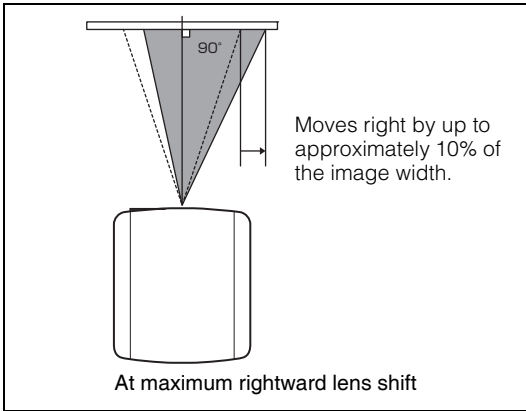

Area where lens movement is not possible

With the Standard Zoom Lens and Long Zoom Lens, when the shift exceeds 44% in the upward direction, the amount of available shift in the left/right directions decreases. When the lens is shifted upward to the maximum (55%), the amount of available shift in the left/right direction is $\pm 2\%$.

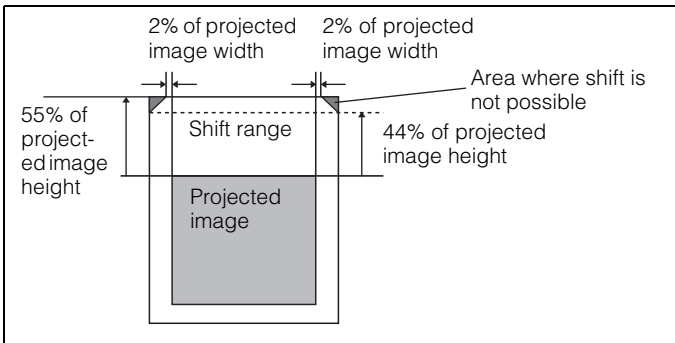

With the Short Fixed Lens, greater shift in the up/down direction reduces the available shift in the left/right direction. When the lens is shifted upward or downward to the maximum, shift in the left/right direction is not possible.

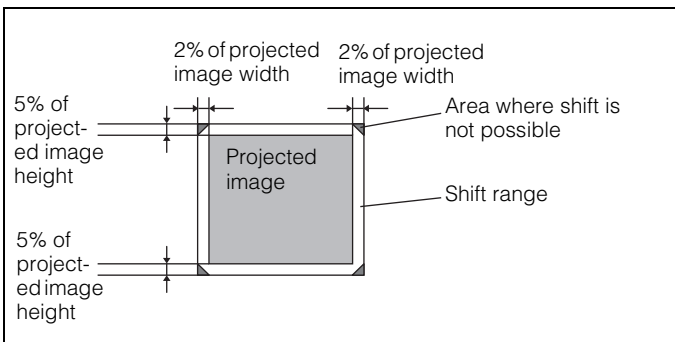



Connecting to AV Equipment

■ Connectable Equipment and Input Terminals

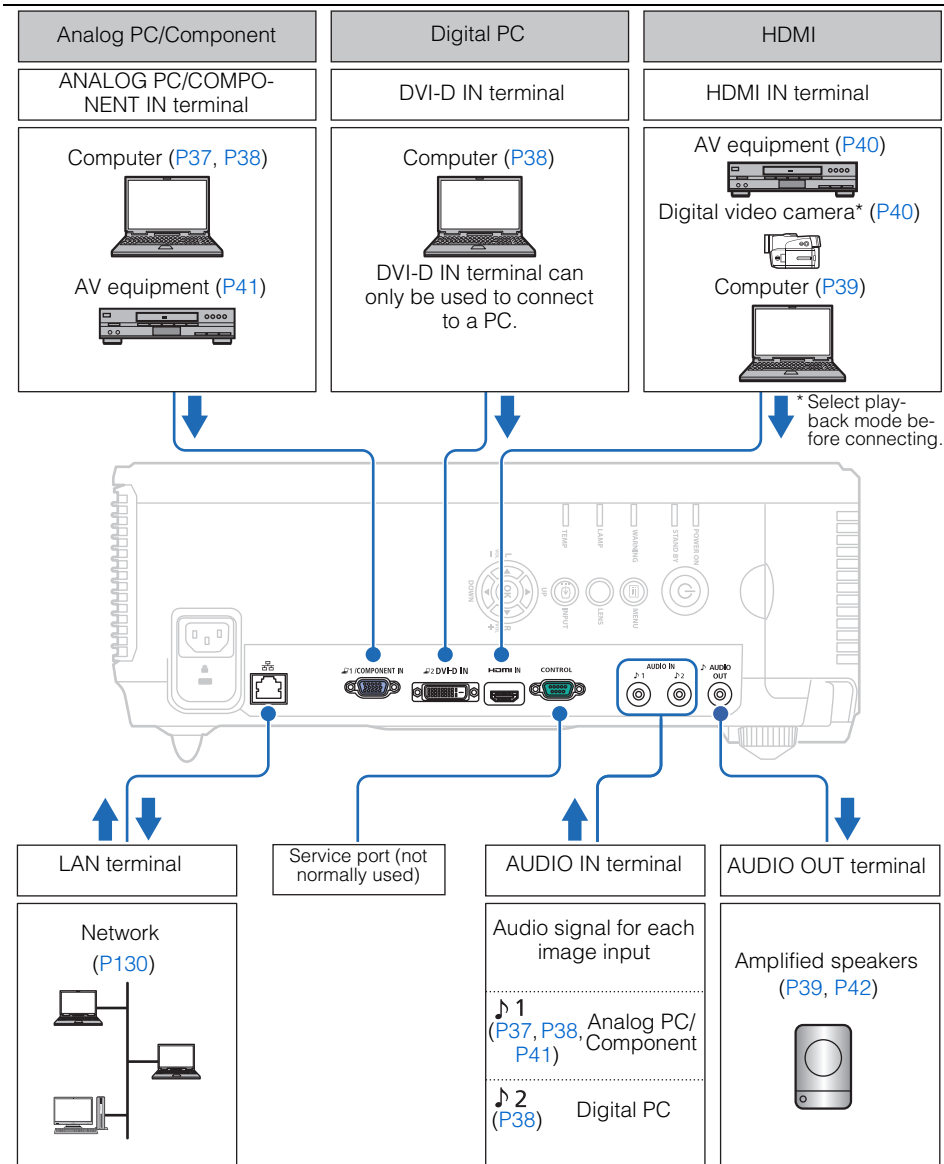
HDMI	Use this name to select the image input. ↓ Direction of signal and data flow
HDMI IN terminal	The name of the terminal to which to connect equipment. (Pxxx): indicates the page(s) to refer to.

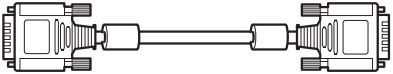
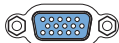
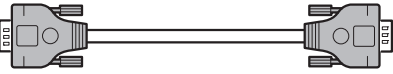
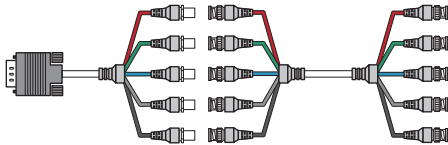
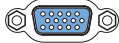
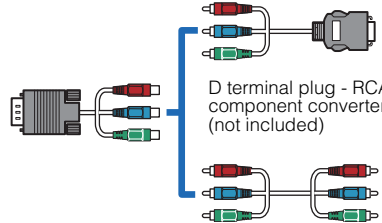

■ Connection Terminal and Connection Cable

Input signal	Input terminal	Types of connection cables
HDMI	HDMI IN 	HDMI cable (not included) 
Digital PC	DVI-D IN 	DVI digital cable (LV-CA29, option) 
Analog PC	ANALOG PC/ COMPONENT IN 	VGA cable (supplied item) 
		BNC cable (not included)  Mini D-sub 15-pin - BNC terminal converter cable (not included) BNC cable (not included)
Component	ANALOG PC/ COMPONENT IN 	Component cable (not included)  D terminal plug - RCA plug component converter cable (not included) RCA plug - RCA plug component cable (not included)

Connecting to a Network

Table of Contents

Safety Instructions

Before Use

Projecting an Image

Useful Functions Available
During a Presentation

Setting Functions from Menus

Installation

Connecting to a Network

Maintenance

Appendix

Index

Operation

Installation and Maintenance

Appendix

Preparing the Remote Control

If the projector is connected to a network, projector error notification mails can be received via a computer and a computer can be used to control the projector. Settings related to the network connection can be made from either the projector side (P136) or computer side (P140).

Depending on the method of network connection, preparation on the computer side may be necessary. The following is an explanation of preparation on the computer side.

Connection Methods

Connect the projector to the computer via LAN.

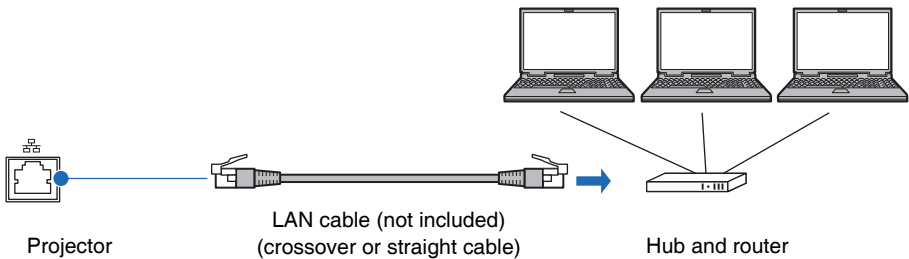

- When the [Network function] setting of the projector is set to [Off] (Network Connections is disabled), switch it to [On] to enable it (P136).
- Referring to "Checking Projector Information" (P108), check that the projector IP address is not overlapped with other computers that are on the same LAN. When you set the IP address of the projector, follow the instruction in "Configuring the Network from the Computer" (P140) on the web screen or refer to "TCP/IP Setting" (P139).
- When you connect the computer to the network first time, it is also necessary to perform settings on the computer. In this case, consult the network administrator regarding the necessary settings.



In a network environment where a DHCP server is operating, choose [On] on the projector [DHCP] screen to enable the DHCP function and connect it (P138).

Setting an IP Address

Following is an explanation of how to set the PC IP address for each operating system.

■ Windows 7

- 1** From the PC [Start] menu, select [Control Panel].
- 2** Click on [Network and Internet Connections], then click on [View network status and tasks].
- 3** From the menu on the left side of the window, click on [Change adapter settings].
- 4** Right-click [Local Area Connection], and open [Properties].
- 5** Select [Internet Protocol Version 4 (TCP/IP)] and click the [Properties] button. Take notes of the original network settings (IP address, subnet mask, default gateway, etc).
- 6** Select [Use the following IP address] and set the IP address and subnet mask. The factory default IP address for the projector is "192.168.254.254". Set an IP address which is different from this.

Example

IP address: 192.168.254.1

Subnet mask: 255.255.255.0

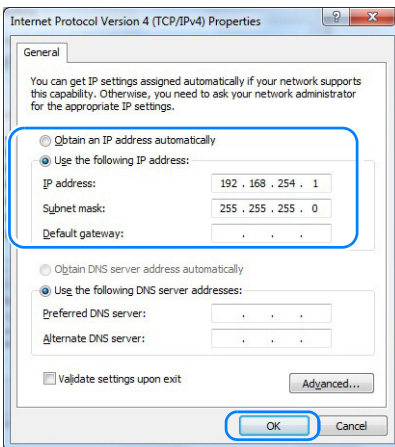

- 7** When the settings are completed, click the [OK] button and then click the [OK] button on the [Local Area Connection Properties] window to close it.

Preparing the Remote Control

■ Windows Vista

- 1** From the PC [Start] menu, select [Control Panel].
- 2** Click on [View network status and tasks].
- 3** From the menu on the left side of the window, click on [Manage network connections].
- 4** Right-click [Local Area Connection], and open [Properties].
- 5** Select [Internet Protocol Version 4 (TCP/IP)] and click the [Properties] button. Take notes of the original network settings (IP address, subnet mask, default gateway, etc).
- 6** Select [Use the following IP address] and set the IP address and subnet mask. The factory default IP address for the projector is “192.168.254.254”. Set an IP address which is different from this.

Example

IP address: 192.168.254.1

Subnet mask: 255.255.255.0

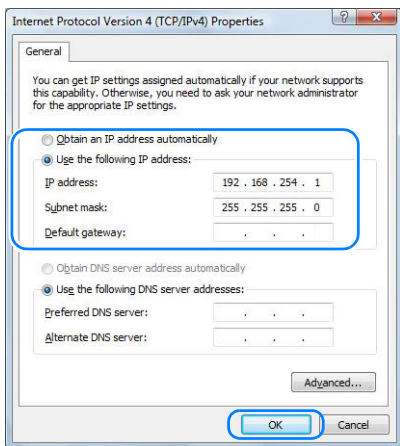

- 7** When the settings are completed, click the [OK] button and then click the [OK] button on the [Local Area Connection Properties] window to close it.

■ Windows XP

- 1** From the PC [Start] menu, select [Control Panel].
- 2** Select [Network and Internet Connections] and open [Network Connections].
- 3** Right-click [Local Area Connection], and open [Properties].
- 4** Select [Internet Protocol (TCP/IP)] and click the [Properties] button. Take notes of the original network settings (IP address, subnet mask, default gateway, etc).
- 5** Select [Use the following IP address] and set the IP address and subnet mask. The factory default IP address for the projector is "192.168.254.254". Set an IP address which is different from this.

Example

IP address: 192.168.254.1

Subnet mask: 255.255.255.0

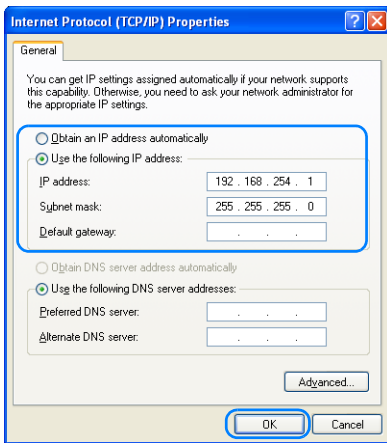

- 6** When the settings are completed, click the [OK] button and then click the [OK] button on the [Local Area Connection Properties] window to close it.

Preparing the Remote Control

■ Mac OS X

- 1 Open the Apple Menu and select [System Preferences].
- 2 In the System Preferences window, click [Network] to display the Network preference window.
- 3 Select [Built-in Ethernet] and click the [TCP/IP] tab. Take notes of the original network settings (IP address, subnet mask, router, DNS server, etc.).
- 4 Create a new network environment and set the IP address and subnet mask. The factory default IP address for the projector is “192.168.254.254”. Set an IP address which is different from this.

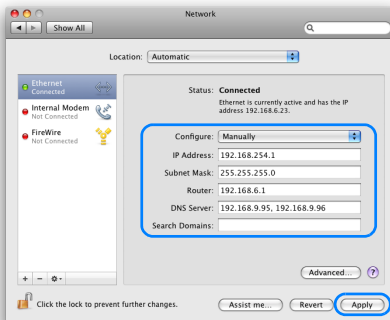

Example

IP address:192.168.254.1

Subnet mask: 255.255.255.0

- 5 Click [Apply] to close the network preference window.

■ Resetting the IP Address Setting of the Computer

Follow the same procedure as for changing the IP address and reset the values to the original values based on the notes taken before the change.

Network Settings on the Projector

From the projector menu screen, network settings can be configured on the [Network Setting] tab. For the menu operations, refer to “How to Use Menus” (P72).

Locking the Network Settings

[Network setting lock]

You can lock/unlock the network settings so that they cannot be changed and cancel the lock.

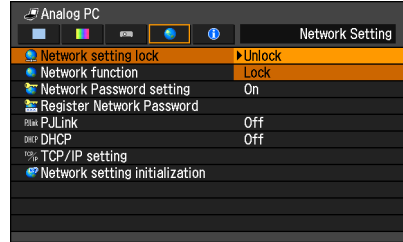
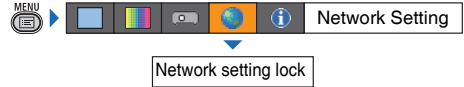

Unlock

Cancel the lock and allow other network settings to be changed. The password must be entered in order to cancel the lock. When [Unlock] is selected, the window shown below appears. Use the [▲], [▼], [◀] / [▶] buttons to enter the 4-digit password.

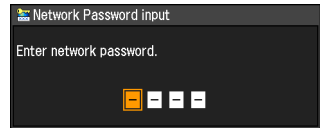

Lock

Lock the settings.

After the **OK** button is pressed to confirm and the **MENU** button is pressed to close the window, the lock is re-engaged. If you change the network settings, be sure to continue operating without closing the window.

- [Lock] is the factory default.
- For the default network password, refer to page 137.

Forcibly canceling the network lock

In the Network Password Input screen, press the buttons in the following sequence to cancel the lock: [▲] [OK] [▶] [OK] [▼] [OK]. This will reset the network password to [▲] [▲] [▲] [▲].

Network Settings on the Projector

Turning On/Off the Network Function

[Network function]

You can turn the projector network function on and off. Power can be saved by turning the function off.

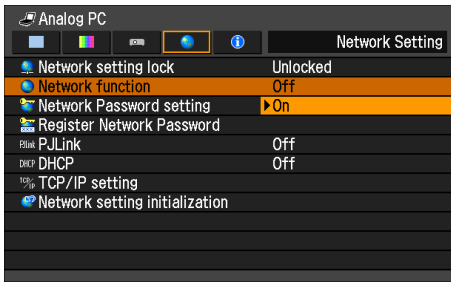

Off Disables the network function.

On Enables the network function.

Press the **OK** button to accept your setting and then press the **MENU** button.

- [Off] is the factory default.

Setting a Network Password

[Network Password setting]

You can set whether or not a password is required in order to change the projector network settings.

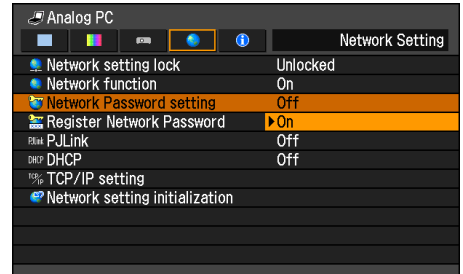

Off A network password is not used.

On A network password is used.

Press the **OK** button to accept your setting and then press the **MENU** button.

- [On] is the factory default.

Registering a Network Password

[Register Network Password]
Register the projector network password.

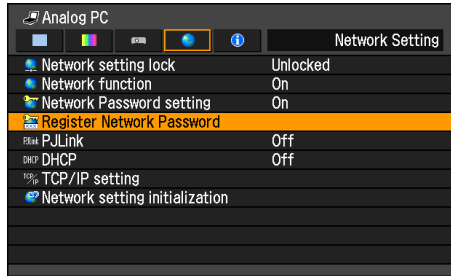

When [Register Network Password] is selected, the window shown below appears. Press the [▲], [▼], [◀] / [▶] buttons in any combination and enter the 4-digit password.

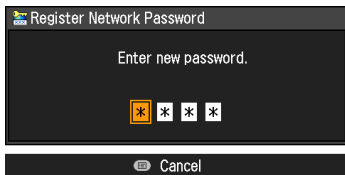

Press the **OK** button to accept your setting and then press the **MENU** button.

- The factory default is [▲] [▲] [▲] [▲].

Turning On/Off the PJLink Function

[PJLink]
You can turn the PJLink network function on and off. When the function is turned on, control is possible via the LAN using commands that meet PJLink standards.

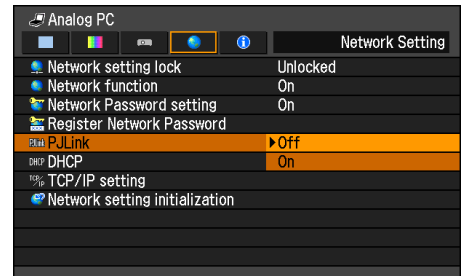

Off Disables the PJLink function.

On Enables the PJLink function.

Press the **OK** button to accept your setting and then press the **MENU** button.

- [On] is the factory default.
- This projector conforms to Class 1 as defined in the PJLink standards of the JBMIA (Japan Business Machine and Information System Industries Association). This projector supports all commands that are defined by PJLink Class 1, and has been verified as conforming to the PJLink standard Class 1 definition.
- For information about using PJLink, refer to "Setting PJLink" (P150).

What is PJLink?

In September 2003, the PJLink Working Group was established under the Data Projector Committee. During the first year, this PJLink Working Group standardized PJLink as a new interface specification for projectors.

PJLink is a unified standard for operation and control of projectors.

It allows centralized control of projectors and operation from a controller for all projectors regardless of manufacturer.

The objective is for JBMIA to improve convenience for users and expand the use of projectors through early systemization for network monitoring and control of projectors, which will become the mainstream in the future.

Class 1: Standardization of control and monitoring specifications for basic projector functions

Basic projector control: Power control, input selection, etc.

Acquisition of projector information and status: Power status, input selection status, error status, lamp use time, etc.

JBMIA: Japan Business Machine and Information System Industries Association

The Japan Business Machine and Information System Industries Association is an organization which was launched in 1960 and changed its name on April 1, 2002.



PJLink is a registered trademark of JBMIA and pending trademark in some countries.

Turning On/Off DHCP Function

[DHCP]

You can turn the projector DHCP function on and off.

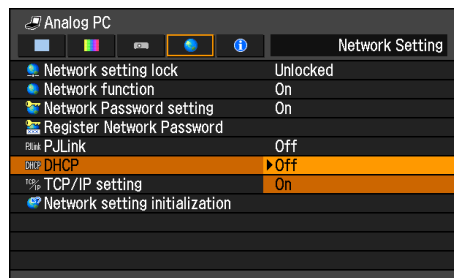
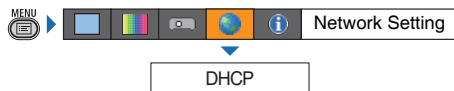

Off Disables the DHCP function. TCP/IP settings are possible.

On Enables the DHCP function. Searches the DHCP server. Because the IP address is acquired from the DHCP server, it is not necessary to enter the TCP/IP setting items (IP address, subnet mask, gateway address).

Press the **OK** button to accept your setting and then press the **MENU** button.

- [Off] is the factory default.

TCP/IP Setting

[TCP/IP setting]

Configure the projector TCP/IP settings.

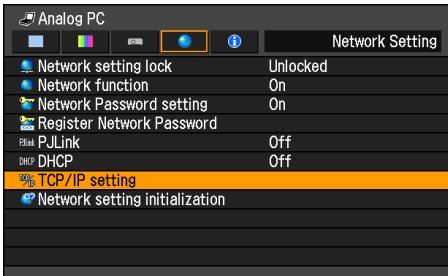
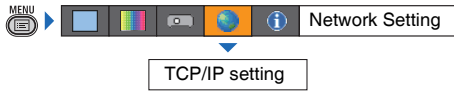

When [TCP/IP setting] is selected, the window shown below appears. Use the [▲] / [▼] buttons to select the IP address, then press the **OK** button. Next, use the [◀] and [▶] buttons to select the digit and the [▲] / [▼] buttons to change the value. Press the **OK** button, then set the subnet mask and gateway address in the same way. Finally, select [Enter].

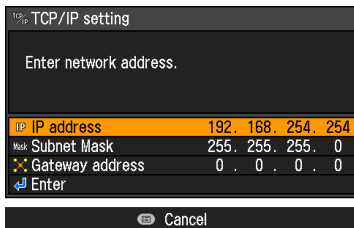

- The factory defaults are shown below.
IP address 192.168.254.254
Subnet mask 255.255.255.0
Gateway address 0.0.0.0
- Setting cannot be made when [DHCP] is [On].
- If an invalid value is entered, the message “Invalid entry” appears. If this occurs, enter a valid value.

Initializing Network Settings

[Network setting initialization]

You can initialize the projector network settings.

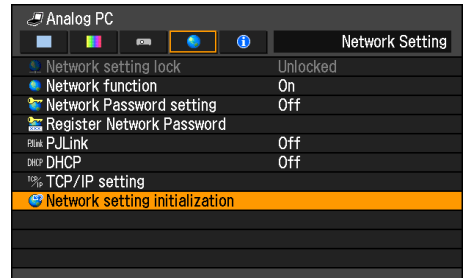
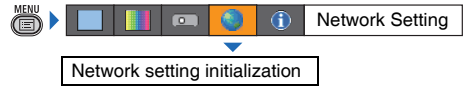

When [Network setting initialization] is selected, the window shown below appears. Select [YES] then press the **OK** button.

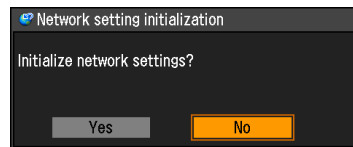

- The following items are initialized.
Network Password setting
Register Network Password
P.JLink
DHCP
IP address
Subnet mask
Gateway address
E-mail sender address
E-mail recipient address
Projector name
Location

Configuring the Network From the Computer

■ Displaying and Configuring the Network Configuration Screen

- 1 Turn on the computer and projector.
- 2 Launch a web browser, enter “http://(projector IP address)” in the address bar, and press the Enter key.
The password input screen appears.

❗ The factory default IP address is “192.168.254.254”. If DHCP settings are used, ask the network administrator for the projector IP address. It is possible to check the IP address from the projector menu.

- 3 Enter the user name and password on the password input screen, then click OK.
The factory default user name is “root” and the password is “system”.

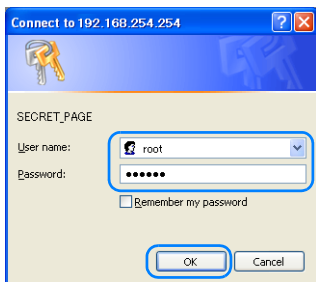

The projector web screen appears in the web browser.

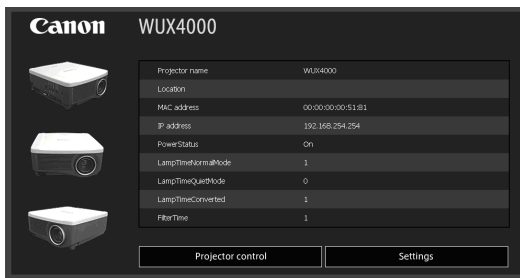

Configuring the Network From the Computer

The following information is displayed.

Projector name	The name of the projector on the network
Location	The location of projector installation
MAC address	The MAC address of the projector
IP address	The IP address of the projector
Power Status	The power status of the projector
Lamp Time Normal Mode	Lamp operating time in [Normal] lamp mode
Lamp Time Quiet Mode	Lamp operating time in [Quiet] lamp mode
Lamp Time Converted	Lamp operating time (converted value)
Filter Time	Filter operating time
Alert	Error message (if an error has occurred) Temperature abnormality Faulty lamp Faulty lamp cover Faulty cooling fan Faulty power supply Faulty lens connector: Error occurring when lens is not installed Faulty air filter unit: Filter error Unknown error



To operate the projector from the computer, click [Projector control] (P151).

4 To configure, click [Settings].
The settings window appears.

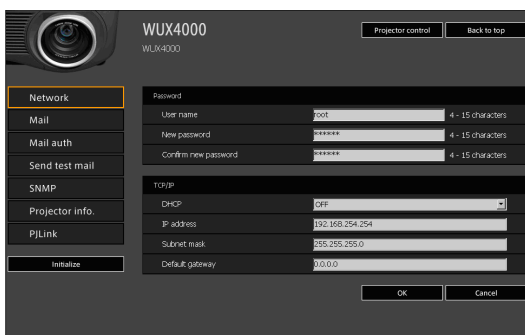

Configuring the Network From the Computer

- 5** Select the function to set from the menu (1), then enter the setting in the displayed field (2) and click [OK] (3).

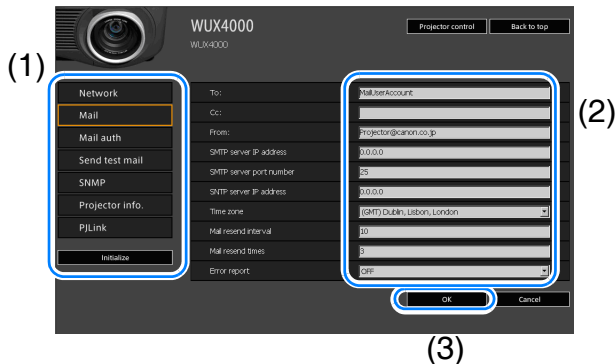

- 6** A confirmation window appears. Check the contents and if they are correct, click [Apply].

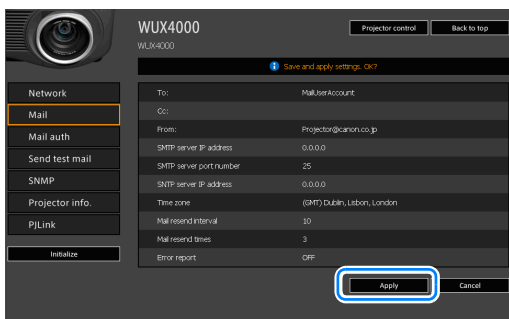

The settings are applied to the projector and “Save completed” is displayed.

- 7** Click [Back to top] to return the web screen to the initial page.

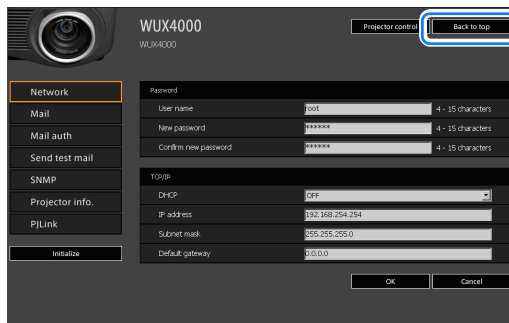

Resetting to Factory Defaults

- 1 Perform steps 1 - 3 of “Displaying and Configuring the Network Configuration Screen” (P140) to display the setting window.
- 2 Click [Initialize].

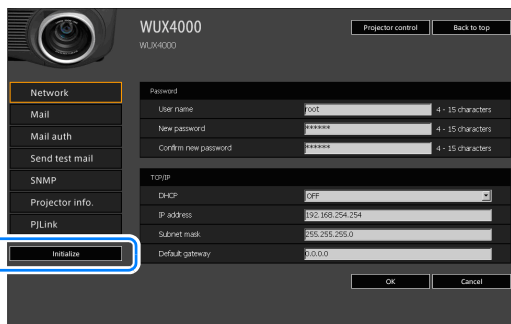

- 3 A confirmation window appears. Click [OK].

Setting Errors

When a setting-related error occurs, the error name is displayed on the screen, and a “!” mark is displayed next to the input field which caused the error.

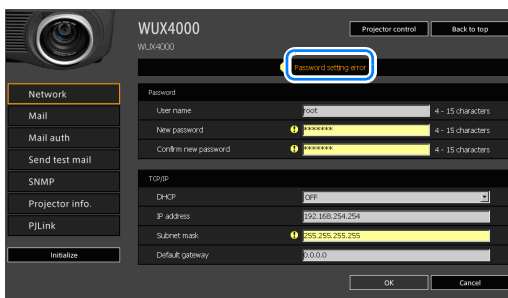

Configuring the Network From the Computer

The error meanings are as shown below.

Error	Meaning
Input error	A setting outside the valid range was set on the setting screen.
Password setting error	The set password and confirmation password did not match.
Invalid SMTP	The SMTP server IP address has not been set.
System failed to connect SMTP server.	Failed to connect to the SMTP server when sending a test mail.
System failed to connect POP3 server.	Failed to connect to the POP3 server attempting to send a test mail.
System doesn't support this auth type.	An authentication type was set which is not supported by the server.
System failed to authenticate.	Authentication failed attempting to send a test mail.
The system failed to send the test mail.	Sending of test mail failed due to a connection failure with the SMTP server or an error which does not ordinarily occur.
Save Failed	Mismatch in settings occurred when settings were changed at the same time from multiple projectors.

Setting Up the Network

■ Setting Basic Information [Network]

From [Network] in the settings window, you can log into the web screen and set basic network information. For the setting procedure, refer to “Displaying and Configuring the Network Configuration Screen” (P140).

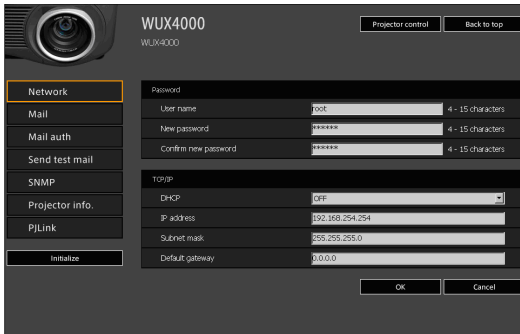

Item	Explanation	Factory default setting
Password		
User name	When logging into the web screen, enter the user name in 1-byte alphanumeric characters and symbols (4 -15 characters).	root
New password	When logging into the web screen, enter the password in 1-byte alphanumeric characters and symbols (4 -15 characters).	system
Confirm new password	For confirmation, enter the same password that you entered in [New password].	system
TCP/IP		
DHCP	Select whether to turn the DHCP function on or off. If the function is on, because the IP address is acquired from the server, it is not possible to enter the [IP address], [Subnet mask], and [Default gateway].	OFF
IP address	Enter the IP address of the projector in 1-byte numbers.	192.168.254.254
Subnet mask	Enter the subnet mask in 1-byte numbers.	255.255.255.0
Default gateway	Enter the default gateway IP address in 1-byte numbers.	0.0.0.0



If settings related to TCP/IP were changed, it is necessary to disconnect and reconnect to the network. If the network subnet mask was changed, select [Subnet mask] in the above window and set the new subnet mask.

Setting Up the Network

■ Setting Up Email [Mail]

From [Mail] in the settings window, you can set the items necessary to send error mails and test mails. For the setting procedure, refer to “Displaying and Configuring the Network Configuration Screen” (P140).

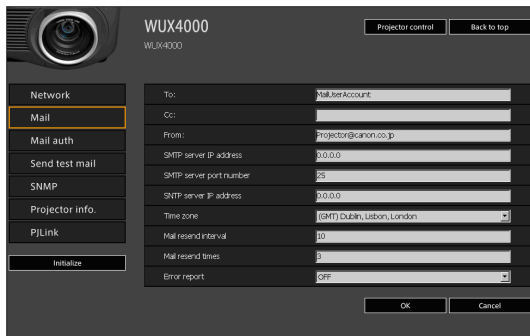

Item	Explanation	Factory default setting
To:	Enter the recipient address for error mails in 1-byte alphanumeric characters and symbols (1 - 63 characters).	MailUserAccount
Cc:	Enter the CC address for error mails in 1-byte alphanumeric characters and symbols (1 - 63 characters).	<Blank>
From:	Enter the sender address for error mails in 1-byte alphanumeric characters and symbols (1 - 63 characters).	Projector@canon.co.jp
SMTP server IP address	Enter the SMTP server IP address in 1-byte numbers.	0.0.0.0
SMTP server port number	Enter the SMTP server port number in 1-byte numbers (1 - 65535).	25
SNTP server IP address	Enter the SNTP server IP address in 1-byte numbers.	0.0.0.0
Time zone	Select the time zone where the projector is used.	(GMT) Dublin, Lisbon, London
Mail resend interval	Enter the interval for resending mail when an error occurred (units: seconds) within the range of 0 - 59 seconds using 1-byte numbers.	10
Mail resend times	Enter the number of times to resend mail when an error occurred within the range of 0 - 255 using 1-byte numbers.	3
Error report	Select whether to turn the error mail sending function on or off.	OFF

■ Mail Authentication Settings [Mail auth]

From [Mail auth] in the settings window, you can configure the settings for authentication of mail that is sent when an error occurs. For the setting procedure, refer to “Displaying and Configuring the Network Configuration Screen” (P140).

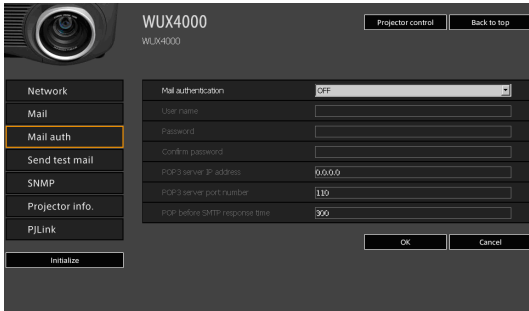

Item	Explanation	Factory default setting
Mail authentication	Select the mail authentication method. If OFF is selected, the other mail authentication settings cannot be changed.	OFF
User name	Enter the user name to use for mail authentication in 1-byte alphanumeric characters and symbols (1 - 63 characters).	<Blank>
Password	Enter the password for mail authentication in 1-byte alphanumeric characters and symbols (1 - 63 characters).	<Blank>
Confirm password	For confirmation, enter the same password as you entered in [Password].	<Blank>
POP3 server IP address	Enter the POP3 server IP address in 1-byte numbers.	0.0.0.0
POP3 server port number	Enter the POP3 server port number in 1-byte numbers (1 - 65535).	110
POP before SMTP response time	Enter the wait time from POP3 authentication to SMTP authentication (units: milliseconds) using 1-byte numbers (0 - 9999 milliseconds).	300

Setting Up the Network

■ Sending a Test Mail [Send test mail]

From [Send test mail] in the settings window, you can send a test mail to the mail address that was set in [Mail]. The settings cannot be changed from this window.

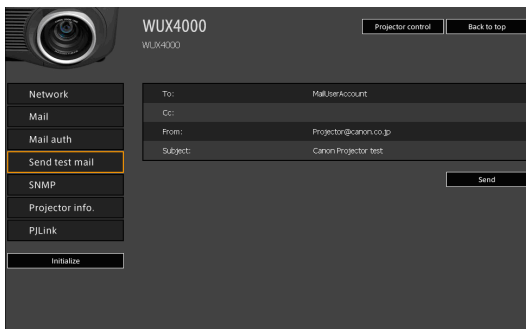

Item	Explanation
To:	The recipient address which was set from [Mail] in the settings window (P146) is displayed.
Cc:	The CC address which was set from [Mail] in the settings window (P146) is displayed.
From:	The sender name which was set from [Mail] in the settings window (P146) is displayed.
Subject:	The predetermined mail title "Canon Projector test" is displayed.

■ SNMP Settings [SNMP]

From [SNMP] in the settings window, you can configure the settings related to control of projectors which use SNMP (Simple Network Management Protocol). For the setting procedure, refer to "Displaying and Configuring the Network Configuration Screen" (P140).

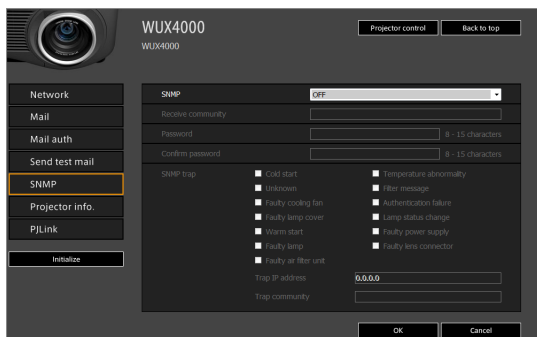

Item	Explanation	Factory default setting
SNMP	Select the SNMP function version. If OFF is selected, the SNMP function will be turned off and the other settings in this window cannot be changed.	OFF
Receive community	Enter the community name which will receive projector information in 1-byte alphanumeric characters and symbols (1 - 15 characters).	<Blank>
Password	Enter the community settings password in 1-byte alphanumeric characters and symbols (8 - 15 characters). This is also used as the password for trapping. It can be set only when the SNMP version is V3.	<Blank>
Confirm password	For confirmation, enter the same password as you entered in [Password].	<Blank>
SNMP trap	Select the type of error to trap. When any of the checkboxes is turned on, it becomes possible to set [Trap IP address] and [Trap community].	OFF (no checkmarks)
Trap IP address	Enter the IP address to send information to when trap occurs. Enter in 1-byte numbers.	0.0.0.0
Trap community	Enter the community name which will send information when trap occurs. Enter in 1-byte alphanumeric characters and symbols (1 - 15 characters).	<Blank>

■ Setting Projector Information [Projector info.]

From [Projector info.] in the settings window, you can set the names and location names which are used to identify projectors when multiple projectors are installed on the network. For the setting procedure, refer to “Displaying and Configuring the Network Configuration Screen” (P140).

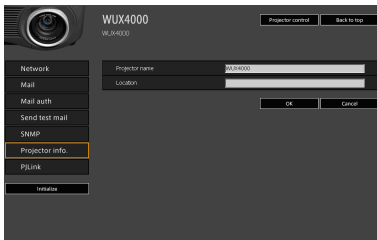

Item	Explanation	Factory default setting
Projector name	Enter the projector name in 1-byte alphanumeric characters and symbols (1 - 63 characters).	WUX4000
Location	Enter the projector installation location in 1-byte alphanumeric characters and symbols (0 - 63 characters).	<Blank>

Setting Up the Network

■ Setting PJLink [PJLink]

From [PJLink] in the setting window, you can set the PJLink functions which are the standard for projector management on a network. For the setting procedure, refer to “Displaying and Configuring the Network Configuration Screen” (P140). For information about PJLink, refer to “What is PJLink?” (P138).

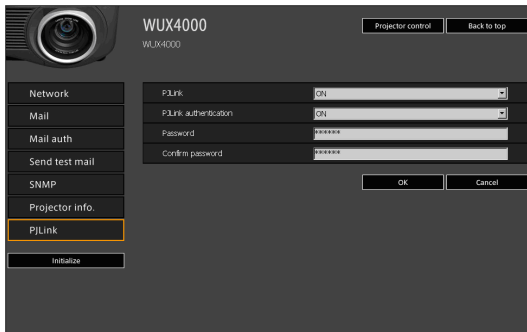

Item	Explanation	Factory default setting
PJLink	Turn the PJLink function on or off. If OFF is selected, the PJLink function will be turned off and the other settings in this window cannot be changed.	ON
PJLink authentication	Select whether to turn the PJLink authentication function on or off. If OFF is selected, [Password] and [Confirm password] cannot be changed.	ON
Password	Enter the PJLink authentication password in 1-byte alphanumeric characters (1 - 32 characters).	system
Confirm password	For confirmation, enter the same password that you entered in [Password].	system

Controlling the Projector from a Computer

When the projector is connected to a network, it is possible to control the projector from a computer via the network.

- 1 Turn on the computer and projector.
- 2 Launch a web browser, enter “http://(projector IP address)” in the address bar, and press the Enter key.
The password input screen appears.
The factory default IP address is “192.168.254.254”. It is possible to check the IP address from the projector menu.
- 3 Enter the user name and password on the password input screen, then click OK.
The factory default user name is “root” and the password is “system”.

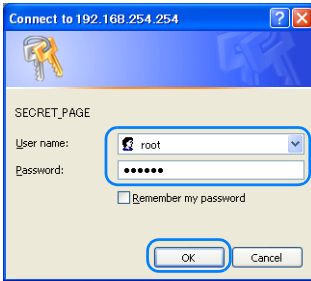

- 4 The projector web screen appears in the web browser. Click [Projector control].

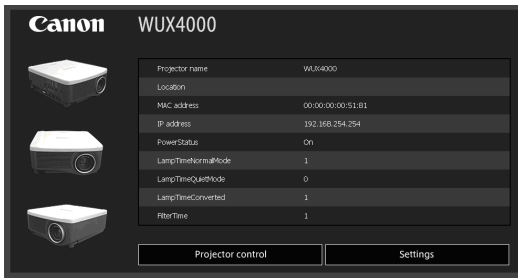

Controlling the Projector from a Computer

- 5** The projector control screen appears. The projector can be controlled from this screen.

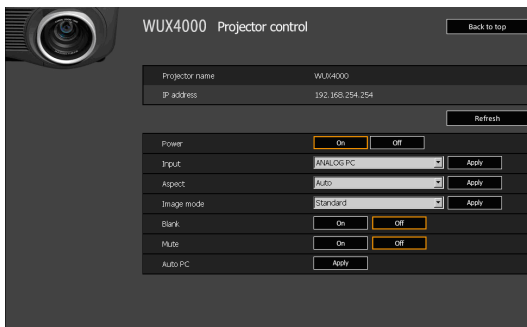

Item	Explanation
Projector name	The name of the connected projector is displayed. (P149)
IP address	The IP address of the connected projector is displayed. (P145)
Refresh	Refreshes the displayed contents with the most recent information.
Power	Turns projector power on or off.
Input	Select an input signal and click [Apply] to change to that input signal. (P46)
Aspect	Select an aspect and click [Apply] to change to that aspect. (P54)
Image mode	Select an image mode and click [Apply] to change to that image mode. (P62)
Blank	Switches the blank setting on or off. (P66)
Mute	Switches the mute setting on or off. (P67)
Auto PC	Performs Auto PC. (P49)
Information	The control results and control error information are displayed at the bottom of the screen.

- 6** When the operations are finished, click [Back to top] to return the initial web screen.

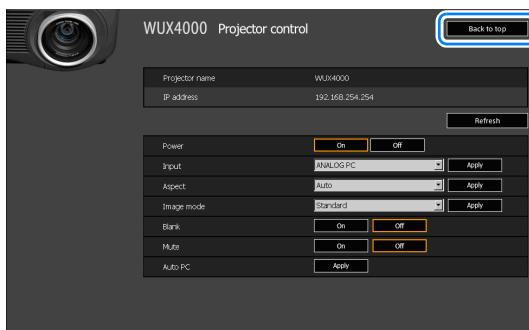

Error Mail

The messages shown in the following error list are sent when an error occurs in the projector.

Error list

Errors related to temperature	Error name	Temperature abnormality
	Text	The temperature inside the projector is too high for some reason or the outside air temperature is higher than the specified one. If the problem is inside the projector, check whether the projector is installed and operated normally, turn off the projector to cool its inside, and retry projection. If the same warning occurs again, the projector may be defective. Contact your Canon dealer.
Errors related to the lamp	Error name	Faulty lamp
	Text	The lamp has burnt out. Replace the lamp with a new one. If the same warning occurs again, the lamp drive circuit may be defective. Contact your Canon dealer.
Errors related to the lamp cover	Error name	Faulty lamp cover
	Text	The lamp cover is open. Check whether the lamp cover is installed properly. If it is installed properly, the lamp cover detection switch may be defective. Contact your Canon dealer.
Errors related to the cooling fan	Error name	Faulty cooling fan
	Text	The cooling fan or another component may be defective. Contact your Canon dealer.
Errors related to the power supply	Error name	Faulty power supply
	Text	The voltage of part of the power supply is abnormally high or any other problem has occurred in the power supply. Contact your dealer.
Errors related to the lens unit	Error name	Faulty lens connector
	Text	The lens cable is not connected to the lens unit. Check whether the lens cable is connected to the lens unit properly. If it is connected properly, the lens connector or cable may be defective. Contact your Canon dealer.
Errors related to the air filter	Error name	Faulty air filter unit
	Text	The air filter unit is not installed properly. Check whether the air filter unit is installed properly. If it is installed properly, the air filter unit detection switch may be defective. Contact your Canon dealer.
Other types of errors	Error name	Unknown Error
	Text	Code in hexadecimal numbers*

* For details, contact your Canon dealer.

Maintenance

Table of Contents

Safety Instructions

Before Use

Projecting an Image

Useful Functions Available
During a Presentation

Setting Functions from Menus

Installation

Connecting to a Network

Maintenance

Appendix

Index

Operation

Installation and Maintenance

Appendix

Cleaning the Projector

Clean the projector frequently to prevent dust from settling on the surface. A dirty lens may ruin the quality of the projected image.



- **When cleaning the projector, make sure to turn off the projector, wait until the cooling fan stops, disconnect the power plug from the AC outlet, and let the projector stand for at least 1 hour. Otherwise, you may get burned because the main unit is very hot immediately after the projector is turned off.**

Wipe the projector's main unit softly with a soft cloth.

If the projector is heavily soiled, soak the cloth in water with a small amount of detergent in it, squeeze the cloth thoroughly, and then wipe the projector with it. After cleaning, wipe the projector with a dry cloth.



- Never use volatile cleaning liquid or benzene, as these may damage the finish of the projector.
- When using a chemical dust cloth, make sure to read the instructions thoroughly.
- When cleaning the projector's lens, use a commonly available air blower or lens cleaning paper. The lens surface is easily damaged, so do not use a hard cloth or tissues.

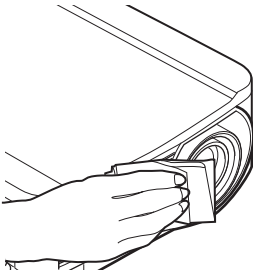

Cleaning and Replacing the Air Filter

Replacing the Air Filter

Follow the procedure below when replacing the air filter.

- 1** Turn off the projector power and remove the power plug.
- 2** Hook your finger onto the handle of the air filter on the side of the projector, and pull the air filter out to remove it.

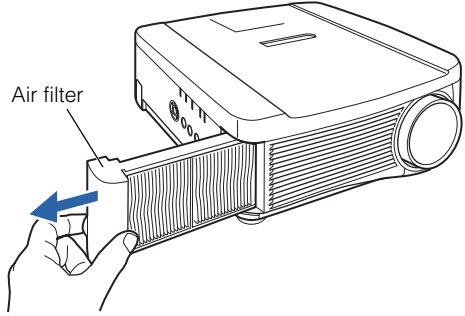

- 3** Remove the filter from the air filter frame. First disengage the tab on the inside, then remove the entire air filter from the frame.

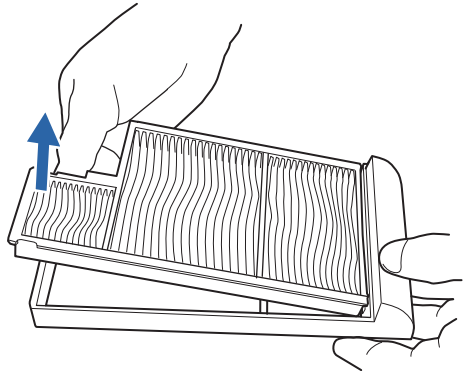

- 4** Install a new air filter into the frame. First insert the air filter tab into the groove on the handle side of the frame, then press the air filter into the frame.

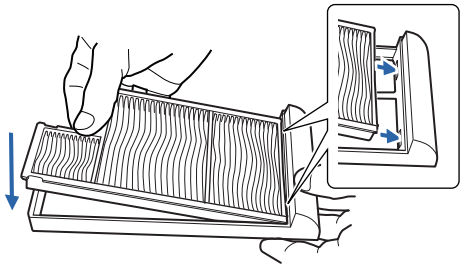

Cleaning and Replacing the Air Filter

- 5** Securely insert the air filter all the way into the projector.

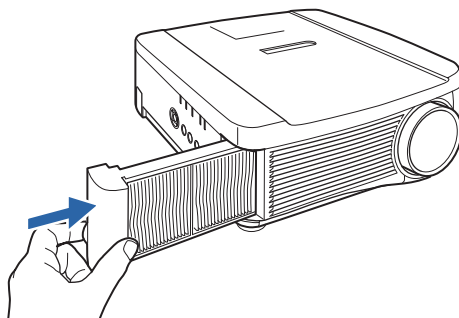

- Handle the air filter carefully. If damaged, the air filter will not work properly.
- When the lamp is replaced, it is recommended that you also replace the air filter.
- An air filter can be ordered from your Canon dealer.
- Replacement air filter part No.: RS-FL01

Cleaning the Air Filter

The air filter protects the lens and mirror inside the projector from dust and dirt. Should the air filter become clogged with dust, the projector may be damaged since it will block the air flow into the projector and raise the internal temperature of the projector. The following screen is displayed when turning on the projector if the air filter needs to be cleaned (after approx. 300 hours). Clean the air filter if such is the case.



Filter cleaning

Clean the filter.

If it is already cleaned, select "Yes".
This message will no longer appear.

Yes

No

- Only the [◀], [▶], **OK** and **POWER** buttons are available while this screen is displayed. (When you press the **POWER** button, the message "Push **POWER** button again to turn off power" appears.)
- After this screen has been displayed for 10 seconds and disappeared, all buttons become operable.

- Hook your finger into the air filter handle on the side of the projector, and remove the air filter. Then use a vacuum cleaner to remove the dust.
- Bring the vacuum cleaner nozzle directly close to the side intake vent and the bottom exhaust vent in order to clean them.
- If the filter replacement screen is displayed when turning on the projector after cleaning the air filter, select [Yes].

Replacing the Lamp

When the usage time of the lamp exceeds a certain amount of time, the following message (two types) is displayed for 10 seconds every time the projector is turned on.

2,700 hours to less than 3,000 hours



Prepare the new lamp when this screen is displayed.

- Only the [◀], [▶], **OK** and **POWER** buttons are available while this screen is displayed.
- When you press the **POWER** button, “Push **POWER** button again to turn off power.” message appears.
- After this screen has been displayed for 10 seconds and disappeared, all buttons become operable.
- This message will not be displayed again if you select [Cancel] in response to the message “Do you want to display this message again?”.

3,000 hours or more



If this screen is displayed, replace the lamp by referring to the procedure on page 160.

- Only the **POWER** button is available while this screen is displayed.
- When you press the **POWER** button, “Push **POWER** button again to turn off power.” message appears.
- When this screen has been displayed for 10 seconds and disappeared, all buttons become operable.
- You can check the usage time of the lamp in [Lamp counter] in the [System settings] menu. (P105)

Replacing the Lamp

Replacement Lamp

This projector uses the following lamp.

Lamp part No.: RS-LP06



- When replacing the lamp, turn off the projector, wait until the cooling fan stops, disconnect the power plug from the AC outlet, and let the projector stand for at least 1 hour. Otherwise, you may get burned because the main unit is very hot immediately after the projector is turned off.



Caution

- Be sure to use the specified lamp.
- A lamp can be ordered from your Canon dealer or the Canon home page.
- Do not touch the inner glass surface when you replace the lamp. Doing so may cause deterioration to the projector's performance.
- Be sure to handle the lamp carefully and correctly since it may break during use if it has been scratched or subjected to impact. If the lamp breaks, contact your Canon dealer and follow the instructions in "Precautions on the lamp" (P19) and "Lamp handling precautions" (P20).
- When replacing the lamp, do not remove any screws other than those specified.

Replacing the Lamp

- 1** Turn off the projector power and remove the power plug.
- 2** Loosen one screw and open the lamp cover in the direction of the arrow.
The lamp cover screw is attached to the lamp cover and designed to prevent it from falling off.

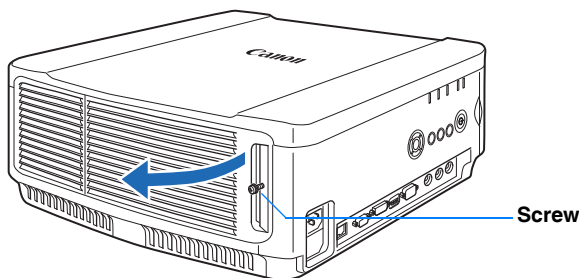

- 3** Loosen the 3 screws on the inside of the lamp unit, then slowly pull out the lamp unit in the direction of the arrow.

Even when the screws are loosened, they will not fall off the lamp unit.

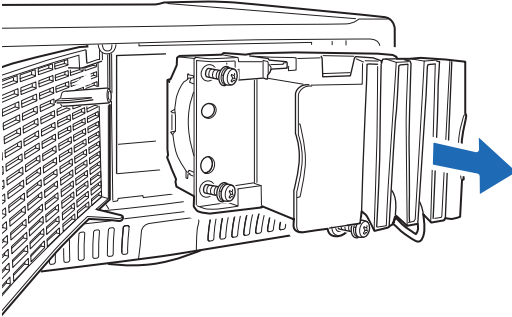

- 4** Fully insert a new lamp unit and secure it with the 3 screws.

- 5** Close the lamp cover and tighten the screws.

- 6** Turn on the power. Bring up the menu and select [System settings] - [Other settings] - [Lamp counter].

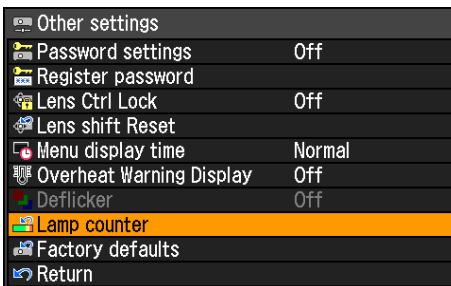
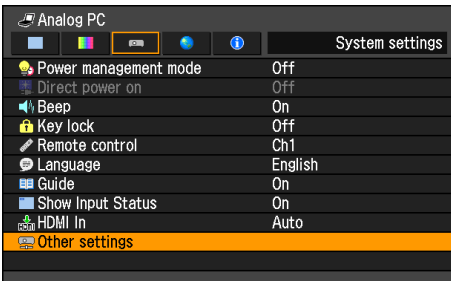

Replacing the Lamp

- 7 Select [Reset] - [OK] to reset the lamp counter.

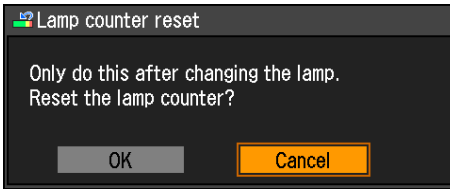
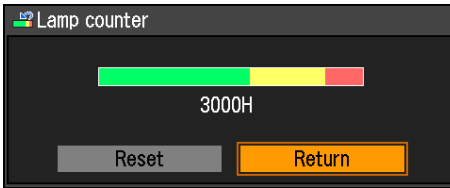

MULTIMEDIA PROJECTOR
WUX4000

Appendix



Appendix

Table of Contents

Safety Instructions

Before Use

Projecting an Image

Useful Functions Available
During a Presentation

Setting Functions from Menus

Installation

Connecting to a Network

Maintenance

Appendix

Index

Operation

Installation and Maintenance

Appendix

Troubleshooting

LED Indicator Meanings

When there is a problem with the projector, the LED indicator on the side of the projector flashes continuously after the projector is turned off.

- Wait until the cooling fan stops and disconnect the power plug from the AC outlet before dealing with the problem.

LED indicator status	Meaning	Countermeasure
WARNING and TEMP are lit.	Temperature abnormality	The temperature inside the projector is too high for some reason or the outside air temperature is higher than the operating range. If the problem is inside the projector, check whether the projector is installed and operated normally, unplug the projector from the power outlet to cool down the projector interior and then restart projection. If the air intake or exhaust vent is blocked, remove the obstacle. If the same warning occurs again, there may be a malfunction in the projector. Contact your Canon dealer.
WARNING and LAMP are lit.	Faulty lamp	The lamp does not illuminate. Turn the power off and then back on and check whether or not the lamp illuminates. Also, check whether the air intake or exhaust vent is blocked, and whether the air filter is clogged with dust. The warning may indicate if the air flow in and out of the projector is blocked, or if the internal temperature of the projector rises. If the air filter is clogged, clean or replace the air filter. (P157, P158) If the lamp does not illuminate, replace it. If the same warning occurs again, there may be a malfunction in the lamp drive circuit. Contact your Canon dealer.
WARNING flashes 3 times, LAMP is lit.	Faulty lamp cover	The lamp cover is open. Unplug the projector from the power outlet, then install the lamp cover correctly and turn on the projector again. If the lamp cover has been installed properly, there may be a malfunction in the lamp cover detection switch. Contact your Canon dealer.
WARNING flashes 4 times.	Faulty cooling fan	There may be a malfunction in the cooling fan or another component. Unplug the projector from the power outlet, then plug it to the outlet and turn on the projector again. Contact your Canon dealer if the same warning occurs again.
WARNING flashes 5 times.	Faulty power supply	Abnormal voltage is applied to some parts in the power supply or another failure may have occurred. Unplug the projector from the power outlet, then plug it back into the outlet and turn on the projector again. Contact your Canon dealer if the same warning occurs again.
WARNING flashes 6 times.	Faulty lens connector	Disconnect the lens connector which joins the lens unit and projector. Contact your Canon dealer.

LED indicator status	Meaning	Countermeasure
WARNING flashes 3 times.	Filter error	The air filter is not installed. Check whether or not the air filter is installed correctly. Contact your Canon dealer if the same warning occurs again.

Symptoms and Solutions

■ You Cannot Turn on the Projector

Cause	Countermeasure
The power cord is not connected correctly.	Check whether the power cord is connected correctly. (P43) Check that [Key lock] is not enabled. (P97)
The power cord has just been connected.	You cannot turn on the projector until the [STAND BY] indicator turns red after connecting the power plug. (P43)
The lamp cover is open.	Unplug the projector from the power outlet, then install the lamp cover correctly and turn on the projector again.
The safety device is activated because the air intake or the exhaust vent is blocked and the internal temperature of the projector has increased.	When the safety device is active, the [STAND BY] indicator does not turn on when you connect the power cord. You cannot disable this safety device. Remove any obstacle that is blocking the air intake or exhaust vent and contact your Canon dealer.
The lens connector is not connected correctly.	Check whether the lens connector is connected correctly. (P120)
The air filter is not installed correctly.	Check whether the air filter is installed correctly. (P157)

■ You Cannot Project an Image from the Projector

Cause	Countermeasure
A connection cable is not connected correctly.	Check whether the projector is connected to the computer or AV equipment correctly. (P40, P46)
20 seconds have not passed since the projector was turned on.	When the projector is turned on, the opening window is displayed for approximately 20 seconds. To project an image immediately, press the OK button on the remote control or side control. (P43)
No image is sent from the AV equipment.	Check whether an image is played on the connected video camcorder, DVD, etc.
The wrong video terminal or signal type is selected.	Check whether the connection to the image terminals has been completed correctly. Also check that the image signal type has been correctly selected. (P37, P46)
No input signal type has been selected.	Press the INPUT button to select the input signal to project. (P47)
The image signal type is incorrect.	Check whether the selected signal type is correct. (P76, P173)

Troubleshooting

Cause	Countermeasure
The BLANK function has been selected.	Press the BLANK button on the remote control. (P66)
No image is projected due to a problem with the computer.	Turn first the projector and then the computer off and then back on again.
The external monitor output is not set on the notebook computer correctly.	Turn on the external monitor output on the notebook computer. To turn on the external monitor output, press the [LCD] or [VGA] function key or a key with an icon for the external monitor, while holding down the [Fn] key on the keyboard of the notebook computer. With Windows 7, you can turn on image output by holding down the Windows logo key and pressing the [P] key. (P45) The combination of keys used to perform this operation varies depending on the model of notebook computer. For more detailed information, refer to the User's Manual that came with your computer.
The displayed image is not the same as that displayed on the computer.	Check whether the dual screen (multi-display) mode is selected on the computer. If the dual screen mode has been selected, change it to the simultaneous display mode on the computer. The output setting method varies among computer manufacturers. For more detailed information, refer to the User's Manual that came with your computer.

■ You Cannot Hear Sound

Cause	Countermeasure
The audio cable is not connected correctly.	Check the audio cable connection. (P37)
The MUTE function is enabled.	Press the MUTE button on the remote control. (P67)
The volume level is adjusted to the minimum.	Press the VOL button on the remote control or the VOL+ button on the side control to adjust the volume level. (P67)
An audio cable with a built-in resistor is used.	Use an audio cable without a built-in resistor.

■ The Projected Image Is Blurred

Cause	Countermeasure
The image is out of focus.	Adjust the focus. (P57)
The distance to the screen is too short.	Check whether the distance to the screen is appropriate. If the distance is shorter than approximately 1.3 m (4.3'), the projector cannot focus on the screen. (P123)
The projector is not placed straight in front of the screen.	Check whether the projector is placed obliquely to the screen. A slight error in the projection angle can be corrected through the keystone adjustment function. (P59)
The projector has been moved to a place where the temperature varies a lot.	When the projector is moved from a location where the temperature is low to a location where the temperature is high, condensation may form on the lens. The condensation will evaporate after a period of time and the projector will be able to project a normal image.
The lens is stained.	Clean the lens. (P156)
The tracking is bad.	Adjust the tracking with the [AUTO PC] or [Tracking] function. (P49, P77)

■ You Cannot Project an Image Appropriately

Cause	Countermeasure
The projected image is inverted in the vertical or horizontal direction.	The ceiling mounted/rear projection setting is incorrect. Check the [Image flip H/V] setting in the [Display settings] menu. (P83)
The dot clock of the input signal is 162 MHz or higher with a BNC cable.	Set the signal dot clock to 162 MHz on your computer.
A VGA cable is used in which some pins are not connected.	Use a VGA cable in which all pins are connected.

■ The Projector Power Turns Off

Cause	Countermeasure
The air intake or exhaust vent is blocked.	Check whether the air intake or exhaust vent is blocked. If the air intake or exhaust vent is blocked, the temperature inside the projector will increase and the power is automatically turned off to protect the projector. (The [WARNING] indicator and [TEMP] indicator are lit.) Wait until the projector temperature drops, then make sure that the intake and exhaust vents are not blocked and turn on the projector. (P26, P27, P43)
The air filter is dirty.	Check whether the air filter is clogged with dust. If the air filter is clogged, clean or replace the air filter. (P157)

Troubleshooting











Cause	Countermeasure
The lamp has broken (or there is a lamp malfunction).	Check whether the lamp has broken. If the lamp has broken, follow the instructions in "Precautions on the lamp" on page 19. If the lamp has not broken, there may be a malfunction with the lamp. Check the lamp by replacing it with a spare lamp if you have one. (P20, P159, P160)
The operating temperature is inappropriate.	Check whether the operating temperature is between 5°C and 35°C. (P22) If you use the projector at 2300 m or higher above sea level, contact your Canon dealer.
Other reasons	The projector may be damaged. Contact your Canon dealer.

■ You Cannot Operate the Remote Control

Cause	Countermeasure
Batteries are not installed properly or they have run out.	Check whether batteries are installed correctly. If batteries are installed correctly, replace them with new batteries. (P24)
You are operating the remote control from the outside of the remote control operating range.	Check whether you are operating the remote control within the remote control operating range. (P25)
There is an obstacle between the projector and the remote control.	Remove the obstacle between the infrared remote receiver of the projector and the remote control or point the remote control to an obstacle-free path.
You are operating the remote control in an unsuitable operating environment.	Check whether the infrared remote receiver of the projector is exposed to direct sunlight or strong light of lighting apparatus. (P25)
The channel setting of the remote control does not match the setting of the projector.	Check whether the channel setting of the remote control has been changed. You can check the [Remote control] setting in the [System settings] menu. (P98)
The key lock function is preventing operation of the remote control.	Check whether [Key lock] is enabled to disable the remote control operation. In the System settings menu, set [Key lock] to [Off]. (P97)











Relationship between Aspect and Screen Aspect

This section describes the relationship between screen aspect (P50) and aspect (P54). To project an image on the whole screen, select the most appropriate screen aspect ratio and aspect according to the aspect ratio of the screen and input signal type.

Screen	Screen aspect ratio setting	Resolution of computer screen	Purpose of projection *	Aspect setting
<div style="border: 1px solid black; padding: 5px; margin-bottom: 5px; text-align: center;">16:9</div> <div style="border: 1px solid black; padding: 5px; text-align: center;">16:10</div>	[16:10], [16:9], [16:9 D. image shift]	WUXGA 16:10	 Project an image in the largest possible size on the screen.	[Auto] (or [Full])
		WSXGA+, WXGA+ 16:10	 Project an image in the largest possible size on the screen.	[Auto] (or [Full])
			 Project the computer screen in the original resolution.	[True size]
		WXGA	 Project an image in the largest possible size on the screen.	[Auto]
			 Project the computer screen in the original resolution.	[True size]
		UXGA 4:3	 Project an image in the largest possible size on the screen.	[Auto] (or [4:3])
		SXGA+, XGA, SVGA, VGA 4:3	 Project an image in the largest possible size on the screen.	[Auto] (or [4:3])
			 Project the computer screen in the original resolution.	[True size]
		SXGA 5:4	 Project an image in the largest possible size on the screen.	[Auto]
			 Project the computer screen in the original resolution.	[True size]

* When the image is projected on a 16:10 screen

Relationship between Aspect and Screen Aspect

Using Screen	Screen aspect ratio setting	PC Resolution of screen	Purpose of projection	Aspect setting
<div style="border: 1px solid black; padding: 5px; width: 40px; margin: 0 auto;">4:3</div>	[4:3] [4:3 D. image shift]	WUXGA 16:10	 Project an image in the largest possible size on the screen.	[Auto]
		WSXGA+, WXGA+ 16:10	 Project an image in the largest possible size on the screen.	[Auto]
			 Project the computer screen in the original resolution.	[True size]
		WXGA	 Project an image in the largest possible size on the screen.	[Auto]
			 Project the computer screen in the original resolution.	[True size]
		UXGA 4:3	 Project an image in the largest possible size on the screen.	[Auto] (or [4:3])
		SXGA+, XGA, SVGA, VGA 4:3	 Project an image in the largest possible size on the screen.	[Auto] (or [4:3])
			 Project the computer screen in the original resolution.	[True size]
		SXGA 5:4	 Project an image in the largest possible size on the screen.	[Auto]
			 Project the computer screen in the original resolution.	[True size]

- If an image from image software with an aspect ratio of 16:9 is not projected correctly, select [16:9] as the screen aspect.
- For a 16:9 image with black borders at the top and bottom, such as a terrestrial broadcast movie, you can project the 16:9 image area so that it is projected on the entire screen by selecting [Zoom] in [Aspect].



[Zoom] is available when [16:10], [16:9] or [16:9 D. image shift] is selected for the screen aspect and [HDMI (480p, 576p)] or [Component (480p, 480i, 576p, 576i)] is selected for the input signal.

- To perform keystone adjustment (P59), select [16:10], [4:3] or [16:9] for [Screen aspect].

Supported Signal Types

This projector supports the following signal types.

If your computer or AV equipment is compatible with any one of these signal types, the projector's Auto PC function selects the input signal type to project an image appropriately.

ANALOG RGB

Resolution (dots)	Signal type	Horizontal frequency (kHz)	Vertical frequency (Hz)
640 x 480	VGA	31.469	59.940
720 x 480	-	31.469	59.940
720 x 576	-	31.250	50.000
800 x 600	SVGA	37.879	60.317
848 x 480	-	31.020	60.000
1024 x 768	XGA	48.363	60.004
1280 x 720	-	37.500	50.000
		45.000	60.000
		47.776	59.870
1280 x 768	WXGA	47.396	59.995
		49.702	59.810
		49.306	59.910
1280 x 800	-	49.306	59.910
1280 x 960	MAC	60.000	60.000
1280 x 1024	SXGA	63.981	60.020
1360 x 768	-	47.712	60.015
1366 x 768	-	47.712	59.790
1400 x 1050	SXGA+	64.744	59.948
		65.317	59.978
		55.935	59.887
1440 x 900	WXGA+	55.469	59.901
		75.000	60.000
1600 x 1200	UXGA	75.000	60.000
1680 x 1050	WSXGA+	64.674	59.883
		65.290	59.954
		56.250	50.000
1920 x 1080	-	67.500	60.000
		74.038	59.950
1920 x 1200	WUXGA	74.038	59.950

DVI

Resolution (dots)	Signal type	Horizontal frequency (kHz)	Vertical frequency (Hz)
640 x 480	D-VGA	31.469	59.940
720 x 480	-	31.469	59.940
720 x 576	-	31.250	50.000
800 x 600	D-SVGA	37.879	60.317
1024 x 768	D-XGA	48.363	60.004
1280 x 720	-	37.500	50.000
		45.000	60.000
		49.702	59.810
1280 x 800	D-WXGA	49.306	59.910
		63.981	60.020
1280 x 1024	D-SXGA	63.981	60.020
1400 x 1050	D-SXGA+	64.744	59.948
		65.317	59.978
		55.935	59.887
1440 x 900	D-WXGA+	55.469	59.901
		75.000	60.000
1600 x 1200	D-UXGA	75.000	60.000
1680 x 1050	D-WSXGA+	64.674	59.883
		65.290	59.954
1920 x 1080	-	56.250	50.000
		67.500	60.000
1920 x 1200	D-WUXGA	74.038	59.950

* The specifications in the table above are subject to change without notice.

* This projector does not support any computer output signal with a dot clock of 162 MHz or higher.

* Use a VGA cable in which all pins are connected. If the cable is a type in which all pins are not connected, the image may not be correctly displayed.

HDMI

Connecting to a Computer

Resolution (dots)	Signal type	Horizontal frequency (kHz)	Vertical frequency (Hz)
640 x 480	VGA	31.469	59.940
800 x 600	SVGA	37.879	60.317
1024 x 768	XGA	48.363	60.004
1280 x 800	WXGA	49.702	59.810
		49.306	59.910
1280 x 1024	SXGA	63.981	60.020
1400 x 1050	SXGA+	64.744	59.948
		65.317	59.978
		55.935	59.887
1440 x 900	WXGA+	55.469	59.901
1600 x 1200	UXGA	75.000	60.000
1680 x 1050	WSXGA+	64.674	59.883
		65.290	59.954
1920 x 1200	WUXGA	74.038	59.950

Connecting with AV equipment

Signal type	Horizontal frequency (kHz)	Vertical frequency (Hz)
480p	31.469	59.940
576p	31.250	50.000
720p	37.500	50.000
	45.000	60.000
1080i	56.250	50.000
	67.500	60.000
1080p	56.250	50.000
	67.500	60.000

COMPONENT

Signal type	Horizontal frequency (kHz)	Vertical frequency (Hz)
480i	15.734	59.940
480p	31.469	59.940
576i	15.625	50.000
576p	31.250	50.000
720p	37.500	50.000
720p	45.000	60.000
1080i	28.125	50.000
1080i	33.750	60.000
1080p	56.250	50.000
1080p	67.500	60.000

Product Specifications

■ Projector

Model name		WUX4000
Display system		RGB liquid crystal system
Optical system		Color separation by dichroic mirror/polarizing beam splitter and color composition by prism
Display device	Type	Reflective liquid crystal panel
	Size / Aspect ratio	0.71" X3 / 16:10
	Drive system	Active matrix system
	Number dots / Total Number dots	2,304,000 (1920 x 1200) x 3 panels / 6,912,000
Projection lens (l)	Zoom ratio / Focal length / F value	1.5x / f = 23.0 - 34.5 mm / F1.89 - F2.65
	Zooming / Focusing system	Electric / Electric
	Lens shift	V: -15% - +55%, H: ±10%
Light source		310-NSHA 300 / 264 W
Image size (projection distance) (*1)		Size 40 to 600 (1.3 m/4.6' to 29.0 m/95.1')
Number of colors		16,770,000 colors (full color)
Brightness		4,000 lumen (during presentation)
Contrast ratio		1000:1 (Full white: Full black, during presentation)
Ratio of brightness at periphery to center		88% (during presentation)
Speaker		5W monaural x 1
Maximum input resolution		1920 x 1200 dots
Video signals	Analog PC input	WUXGA/UXGA/WXSGA+/SXGA+/WXGA+/SXGA/WXGA/XGA/SVGA/VGA (Scan frequency: Horizontal 15 - 75 kHz, Vertical 50 - 85 Hz)
	Digital PC input	WUXGA/UXGA/WXSGA+/SXGA+/WXGA+/SXGA/WXGA/XGA/SVGA/VGA
	Component input	1080p, 1080i, 720p, 576i, 576p, 480i, 480p
	HDMI input	1080p, 1080i, 720p, 576p, 480p
Input terminal	DVI-D IN terminal	Digital PC (24-pin DVI connector)
	HDMI IN terminal	HDMI (deep color)
	ANALOG PC/COMPONENT IN terminal	Analog PC, Component (mini D-sub 15-pin)
	CONTROL terminal	RS-232C (D-sub 9-pin)
	AUDIO IN Terminal	Audio signal (3.5Ø stereo mini jack x 2)
AUDIO OUT Terminal		Audio signal (3.5Ø stereo mini jack)
LAN terminal		Network connection (RJ-45)
Input signal	Digital PC	TMDS (Transition Minimized Differential Signaling)
	Analog PC	0.7Vp-p, positive polarity, impedance = 75Ω Horizontal/vertical synchronization: 1 TL level, negative or positive polarity Composite synchronization in G signal: 0.3Vp-p, negative polarity, impedance = 75Ω
	Component video	COMPONENT: Separate Y Cb/Pb Cr/Pr signal Y: 1Vp-p, negative synchronization, impedance = 75Ω Cb/Pb: 0.7Vp-p, impedance = 75Ω Cr/Pr: 0.7Vp-p, impedance = 75Ω
	Audio	Impedance = 47kΩ or more
Noise (normal mode / silent mode)		39 / 36dB
Operating temperature		5°C - 35°C
Power supply		AC100V - 240V 50/60Hz
Power consumption (normal mode / silent mode / standby / standby with LAN OFF)		410W/365W/1.7W/0.35W
Dimensions		380 mm (W) x 170 mm (H) x 430 mm (D) / 15.0 (W) x 6.8 (H) x 16.9 (D) in (not including the projection)
Weight		8.5 kg / 18.7 lbs (not including projection lens unit)
Accessories		Remote control, remote control dry-cell batteries, power cord, PC connection cable, User's Manual / Installation Manual, warranty certificate

*1 When standard zoom lens is used

* 99.99% or more of the LCD panel pixels are effective. During projection, 0.01% or less of pixels may stay lit or unlit due to the characteristics of the LCD panel.

* Using the projector continuously for an extended period of time may accelerate the deterioration of optical parts.

* This projector conforms to JIS C 61000-3-2.

■ Remote control

Power supply	DC 3.0V, using two AAA-size batteries
Operating range	Approx. 8 m± 25° horizontal and vertical (to infrared remote receiver)
Dimensions	43 mm (W) x 23 mm (H) x 135 mm (D) / 1.7 (W) x 0.9 (H) x 5.3 (D) in.
Weight (not including batteries)	56 g

■ Specification of Each Lens Unit (Option)

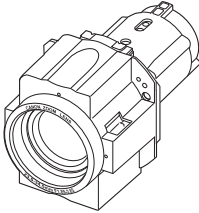
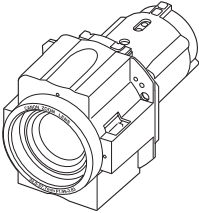
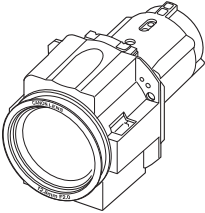
Name	Standard Zoom Lens	Long Zoom Lens	Short Fixed Lens
Model number	RS-IL01ST	RS-IL02LZ	RS-IL03WF
External View			
Focal length	23.0 - 34.5 mm (0.9 - 1.4")	34.0 - 57.7 mm (1.3 - 2.3")	12.8 mm (0.5")
F number	1.89 - 2.65	1.99 - 2.83	2.0
Projection distance	1.3 - 29.0 m (4.6 - 95.1')	1.9 - 48.5 m (6.2 - 159.1')	0.7 - 5.2 m (2.3 - 17.1')
Lens shift	Vertical	-15% to 55%*	-5% to 5%
	Horizontal	-10% to 10%	-2% to 2%
Width	97.4 mm (3.8")	97.4 mm (3.8")	97.4 mm (3.8")
Height	106.5 mm (4.2")	106.5 mm (4.2")	106.5 mm (4.2")
Length	173.4 mm (6.8")	173.4 mm (6.8")	175.2 mm (6.9")
Weight	550 g (1.2 lbs)	755 g (1.7 lbs)	910 g (2.0 lbs)
Zoom ratio	1.5x	1.7x	-
Size 100 projection distance	3.2 - 4.8 m (10.5 - 15.7')	4.7 - 8.0 m (15.4 - 26.2')	1.7 m (5.6')

* There are areas where shift is not possible at the top left and right. For details, refer to "Area where lens movement is not possible" (P125).

Product Specifications

External View

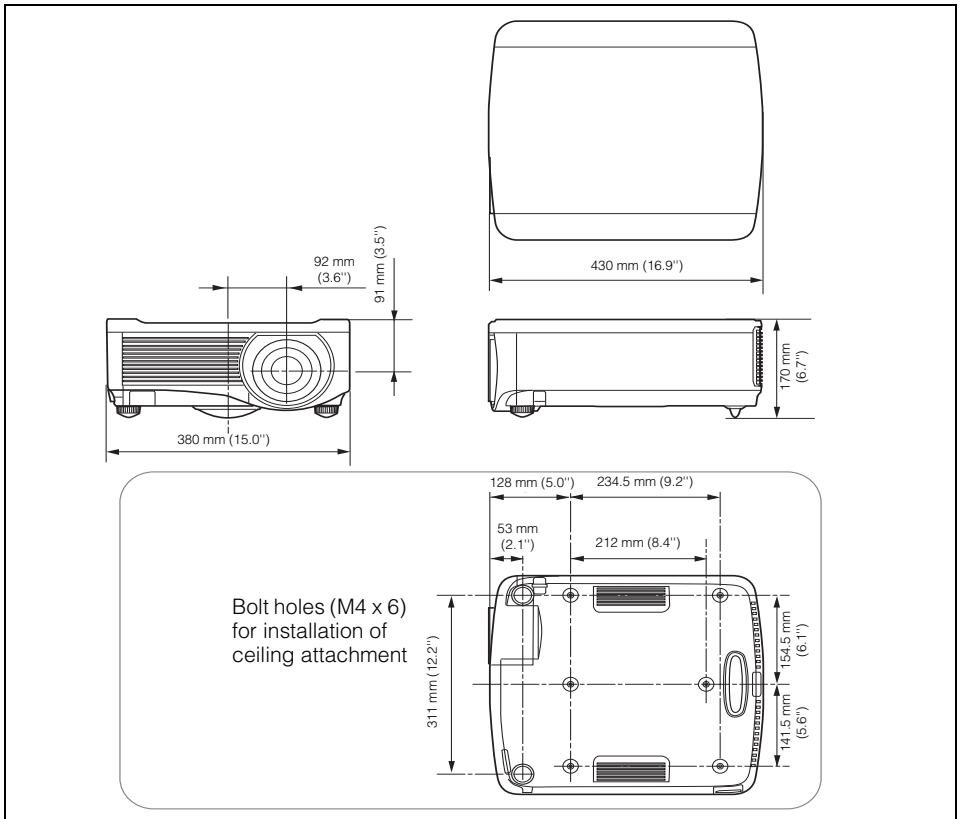

ANALOG PC/COMPONENT IN Terminal

This terminal is used as a computer ANALOG PC input or COMPONENT input terminal. Use a D-sub computer cable for connection. The terminal specifications for the ANALOG PC input and COMPONENT input are the same.

Mini D-sub 15-pin

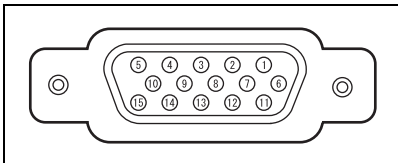

Pin No.	Signal	Pin No.	Signal
1	R	9	+5 V power
2	G	10	Ground (Vertical sync.)
3	B	11	Monitor ID0
4	Monitor ID2	12	DDC data
5	Ground (Horizontal sync.)	13	Horizontal sync.
6	Ground (R)	14	Vertical sync.
7	Ground (G)	15	DDC clock
8	Ground (B)		

■ Service Port (CONTROL)

Pin assignment

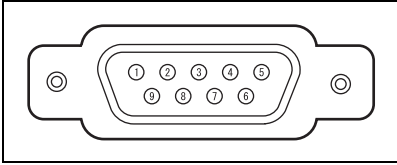

Pin No.	Signal
1	OPEN
2	RxD
3	TxD
4	OPEN
5	GND
6	OPEN
7	OPEN
8	OPEN
9	OPEN

Communication format

Communication mode : RS-232-C, asynchronous, half-duplex communication

Communication speed : 19200bps

Character length : 8 bits

Stop bits : 2 bits

Parity : None

Flow control : None

Control commands

Commands		ASCII representation	Binary representation
Power supply	Power on	POWER ON<CR>	50h 4Fh 57h 45h 52h 20h 4Fh 4Eh 0Dh
	Power off	POWER OFF<CR>	50h 4Fh 57h 45h 52h 20h 4Fh 46h 46h 0Dh
Power status acquisition		GET POWER<CR>	47h 45h 54h 20h 50h 4Fh 57h 45h 52h 0Dh
Input source	Digital PC	INPUT=D-RGB<CR>	49h 4Eh 50h 55h 54h 3Dh 44h 2Dh 52h 47h 42h 0Dh
	Digital Video	INPUT=HDMI<CR>	49h 4Eh 50h 55h 54h 3Dh 48h 44h 4Dh 49h 0Dh
	Analog PC	INPUT=A-RGB<CR>	49h 4Eh 50h 55h 54h 3Dh 41h 2Dh 52h 47h 42h 0Dh
	Component	INPUT=COMP<CR>	49h 4Eh 50h 55h 54h 3Dh 43h 4Fh 4Dh 50h 0Dh
Input source acquisition		GET INPUT<CR>	47h 45h 54h 20h 49h 4Eh 50h 55h 54h 0Dh
Image mode	STANDARD	IMAGE=STANDARD<CR>	49h 4Dh 41h 47h 45h 3Dh 53h 54h 41h 4Eh 44h 41h 52h 44h 0Dh
	PRESENTATION	IMAGE=PRESENTATION<CR>	49h 4Dh 41h 47h 45h 3Dh 50h 52h 45h 53h 45h 4Eh 54h 41h 54h 49h 4Fh 4Eh 0Dh
	VIVID PHOTO	IMAGE=VIVID_PHOTO<CR>	49h 4Dh 41h 47h 45h 3Dh 56h 49h 56h 49h 44h 5Fh 50h 48h 4Fh 54h 4Fh 0Dh
	PHOTO sRGB	IMAGE=PHOTO_SRGB<CR>	49h 4Dh 41h 47h 45h 3Dh 50h 48h 4Fh 54h 4Fh 5Fh 53h 52h 47h 42h 0Dh
	DYNAMIC	IMAGE=DYNAMIC<CR>	49h 4Dh 41h 47h 45h 3Dh 44h 59h 4Eh 41h 4Dh 49h 43h 0Dh
	VIDEO	IMAGE=VIDEO<CR>	49h 4Dh 41h 47h 45h 3Dh 56h 49h 44h 45h 4Fh 0Dh
	CINEMA	IMAGE=CINEMA<CR>	49h 4Dh 41h 47h 45h 3Dh 43h 49h 4Eh 45h 4Dh 41h 0Dh

Product Specifications

Commands		ASCII representation	Binary representation
Image mode	USER 1	IMAGE=USER_1<CR>	49h 4Dh 41h 47h 45h 3Dh 55h 53h 45h 52h 5Fh 31h 0Dh
	USER 2	IMAGE=USER_2<CR>	49h 4Dh 41h 47h 45h 3Dh 55h 53h 45h 52h 5Fh 32h 0Dh
	USER 3	IMAGE=USER_3<CR>	49h 4Dh 41h 47h 45h 3Dh 55h 53h 45h 52h 5Fh 33h 0Dh
	USER 4	IMAGE=USER_4<CR>	49h 4Dh 41h 47h 45h 3Dh 55h 53h 45h 52h 5Fh 34h 0Dh
	USER 5	IMAGE=USER_5<CR>	49h 4Dh 41h 47h 45h 3Dh 55h 53h 45h 52h 5Fh 35h 0Dh
Image mode acquisition		GET IMAGE<CR>	47h 45h 54h 20h 49h 4Dh 41h 47h 45h 0Dh
Brightness	Brightness value setting	BRI=<value><CR>	42h 52h 49h 3Dh <numeric code> 0Dh
Brightness acquisition		GET BRI<CR>	47h 45h 54h 20h 42h 52h 49h 0Dh
Sharpness	Sharpness value setting	SHARP=<value><CR>	53h 48h 41h 52h 50h 3Dh <numeric code> 0Dh
Sharpness acquisition		GET SHARP<CR>	47h 45h 54h 20h 53h 48h 41h 52h 50h 0Dh
Contrast	Contrast value setting	CONT=<value><CR>	43h 4Fh 4Eh 54h 3Dh <numeric code> 0Dh
Contrast acquisition		GET CONT<CR>	47h 45h 54h 20h 43h 4Fh 4Eh 54h 0Dh
Aspect	Auto	ASPECT=AUTO<CR>	41h 53h 50h 45h 43h 54h 3Dh 41h 55h 54h 4Fh 0Dh
	4:3	ASPECT=4:3<CR>	41h 53h 50h 45h 43h 54h 3Dh 34h 3Ah 33h 0Dh
	16:9	ASPECT=16:9<CR>	41h 53h 50h 45h 43h 54h 3Dh 31h 36h 3Ah 39h 0Dh
	Zoom	ASPECT=ZOOM<CR>	41h 53h 50h 45h 43h 54h 3Dh 5Ah 4Fh 4Fh 4Dh 0Dh
	True size	ASPECT=TRUE<CR>	41h 53h 50h 45h 43h 54h 3Dh 54h 52h 55h 45h 0Dh
Full	ASPECT=FULL<CR>	41h 53h 50h 45h 43h 54h 3Dh 46h 55h 4Ch 4Ch 0Dh	
Aspect value acquisition		GET ASPECT<CR>	47h 45h 54h 20h 41h 53h 50h 45h 43h 54h 0Dh
Lamp mode	Normal	LAMP=NORMAL<CR>	4Ch 41h 4Dh 50h 3Dh 4Eh 4Fh 52h 4Dh 41h 4Ch 0Dh
	Quiet	LAMP=SILENT<CR>	4Ch 41h 4Dh 50h 3Dh 53h 49h 4Ch 45h 4Eh 54h 0Dh
Lamp mode value acquisition		GET LAMP<CR>	47h 45h 54h 20h 4Ch 41h 4Dh 50h 0Dh
Blank	Blank On	BLANK=ON<CR>	42h 4Ch 41h 4Eh 4Bh 3Dh 4Fh 4Eh 0Dh
	Blank Off	BLANK=OFF<CR>	42h 4Ch 41h 4Eh 4Bh 3Dh 4Fh 46h 46h 0Dh
Blank acquisition		GET BLANK<CR>	47h 45h 54h 20h 42h 4Ch 41h 4Eh 4Bh 0Dh

Index

Numerics

6-axis color adjust 93

A

Adjusting Keystone Distortion 59

Adjusting the focus 57

Adjusting the Volume 67

Air filter 157

Ambient light 91

Analog PC 37, 38

ANALOG PC/COMPONENT IN
Terminal 32, 37, 38, 41, 46, 127

Aspect 50, 54, 75, 171

AUDIO IN Terminal 32, 37, 38, 41

AUDIO OUT Terminal 32, 39, 42

Auto (Aspect) 54

AUTO PC 49

B

Beep 97

BLANK 66

Brightness 88

C

Ceiling mounted 83

Channel setting 98

Component 41, 46, 76, 127

Connection to Computer 37

Contrast 88

D

D. ZOOM 68

D.SHIFT/KEYSTONE 52, 59

DHCP 138

Digital Image Shift 52

Digital PC 38, 46, 127

Direct power on 96

Display Resolution
(Preparing the Computer) 48

Display settings menu 72

Displaying logo 85

DVI 38, 46, 127

DVI-D IN 38

DVI-D IN Terminal 32

Dynamic gamma 92

F

Factory defaults 107

FOCUS 57

FREEZE 66

G

Guide 99

H

HDMI 39, 40, 46, 127

HDMI color space 80

HDMI IN Terminal 32, 39, 40

HDMI input level 80

HDMI over scan 81

Horizontal pixels 79

Horizontal position 78

I

IMAGE 63

Image adjustment menu 72

Image mode 86

Image Mode (Image Quality) 62

Information 72, 108

INPUT 47

Input signal select 46, 76

Input Terminal 32

 Connecting to AV Equipment 40

 Connection to Computer 37

K

Key lock 97

Keystone 59

L

LAMP 95

Lamp counter 105

Lamp mode 95

Lamp replacement 105, 159, 160

LAN port 32

Language 99

- LED indicator 166
- M**
- Making a Gamma Correction 89
- Memory Color Correction 93
- MENU 72
- Menu display time 103
- Menu position 82
- MUTE 67
- N**
- Network function 136
- Network Setting 72
- Network setting initialization 139
- Noise reduction 92
- O**
- OK 29
- P**
- Password settings 101
- PJLink 137
- POWER 43, 64, 96
- Power Management 44
- Power management mode (settings) 96
- Power Saving (Power Management) 44
- Progressive 81
- Projector on 85
- P-TIMER 69
- R**
- Rear projection 83
- Register Network Password 137
- Register password 102
- Remote control 25, 28, 98
- Reset 95, 107
- Reversing Projection (Ceiling mounted/
Rear projection) 83
- S**
- Screen aspect 50, 85, 171
- Screen color 82
- Screen when blank 84
- Selecting a language 44, 99
- Selecting an Image Quality 86
- Setting a network password 136
- Setting Display Status 75
- Setting Various Functions 96
- Sharpness 89
- Side control 30
- Signal type 173
- System settings menu 72
- T**
- TCP/IP settings 139
- Total dots 77
- Tracking 77
- True size (Aspect) 54
- Turning on external monitor output
(preparing the notebook
computer) 45
- V**
- Vertical pixels 79
- Vertical position 78
- VOL 67
- W**
- WARNING indicator 30, 166
- Z**
- ZOOM 56
- Zoom (Aspect) 54
- Zooming an Image 68

Option

- | | |
|--|---|
| <ul style="list-style-type: none">• Lamp
Part No.: RS-LP06• Ceiling attachment
Part No.: RS-CL11• Ceiling-mount pipe (400 - 600 mm)
Part No.: RS-CL08*• Ceiling-mount pipe (600 - 1000 mm)
Part No.: RS-CL09* | <ul style="list-style-type: none">• Air filter
Part No.: RS-FL01• Standard Zoom Lens
Part No.: RS-IL01ST• Long Zoom Lens
Part No.: RS-IL02LZ• Short Fixed Lens
Part No.: RS-IL03WF |
|--|---|

* Use the above materials to hang the projector from the ceiling. For details, refer to the assembly and installation manual provided with the ceiling attachment RS-CL11.

• Installing/Removing the Lens Unit

It is possible to use the projector by replacing the lens unit. Regarding installation and replacement of the lens unit, contact a qualified technician or Canon dealer for your safety. Do not attempt installation and replacement of the lens unit yourself.

• To a qualified technician or Canon dealer

Before installation and replacement the lens unit, check the part number and use the correct lens unit.

Menu Configuration

Display settings Menu

Aspect	Digital PC/Analog PC	P75
	Auto *	
	Full	
	16:9	
	4:3	
	True size	
	HDMI	
	Auto *	
	Full	
	16:9	
	4:3	
	Zoom	
	True size	
	Component	
	Auto *	
	16:9	
	4:3	
Zoom		
True size		

Input signal select	Analog PC	P76
	640x480	
	:	
	1920x1200	
	Component	P76
	Auto *	
	1080p	
	1080i	
	1035i	
	720p	
	576p	
	480p	
	576i	
	480i	

Input signal settings	Analog PC	
	Total dots	P77
	Tracking	P77
	Horizontal position	P78
	Vertical position	P78
	Horizontal pixels	P79
	Vertical pixels	P79

HDMI input level	HDMI	P80
	Auto *	
	Normal	
	Expanded	

HDMI color space	HDMI	P80
	Auto *	
	RGB YCbCr	

HDMI over scan	HDMI	P81
	Off *1	
	On *2	

Progressive	Component/HDMI	P81
	Off	
	On	
	Auto *	

Menu position P82

Screen color	Normal *	P82
	Greenboard	
	Adjust	Red/Green/ Blue

Image flip H/V	None *	P83
	Ceiling mounted	
	Rear	
	Rear, Ceiling mounted	

User screen settings

No signal screen	Black	P84
	Blue*	

Screen when blank	Black *	P84
	Blue	

Projector on	Skip	P85
	Canon logo*	

Return

Screen Aspect	16:10*	P85
	16:9	
	4:3	
	16:9 D. image shift	
	4:3 D. image shift	



Menu Configuration

Image Adjustment Menu

Image mode	COMMON	P86
	Standard *	
	Photo/sRGB	
	User 1 - 5 (as creating profile)	
	Digital PC/Analog PC	P86
	Presentation	
	VividPhoto	
	Component/HDMI	P86
	Dynamic	
	Video	
	Cinema	

Create Profile	P87
Baseline Image Mode (when user memory is selected)	P87
Brightness	P88
Contrast	P88
Sharpness	P89
Gamma	P89

Color adjustment P90

Color level
Color balance
Color temperature
R Gain
G Gain
B Gain
R Offset
G Offset
B Offset

Advanced adjustment		
Ambient light	Off * P91	
	Adjust	
	Type	Tungsten
		Fluorescent
		Fluorescent H
	Level	L
		M
		H
	Return	
Noise reduction	Component/HDMI P92	
	Off*	
	Weak	
	Middle	
	Strong	
Dynamic gamma	Off *1 P92	
	Weak *2	
	Middle	
	Strong	
Mem. color correct	Off * P93	
	L	
	M	
	H	
6-axis color adjust	Off * P93	
	Adjust	Hue/Saturation/ Brightness
	Reset	
Fine-Tune Gamma	P94	
	Return	
Lamp mode	Normal * P95	
	Quiet	
Reset	OK/Cancel P95	

* : Factory defaults (setting after reset)

*1: Factory defaults for ANALOG PC/DIGITAL PC/HDMI (when [HDMI In] is [Computer])

*2: Factory defaults for COMPONENT/HDMI (when [HDMI In] input is [Auto])

System Settings Menu

Power management mode	Off *	P96
	Standby	
	Exit	
Direct power on	Off *	P96
	On	
Beep	Off	P97
	On *	
Key lock	Off *	P97
	Main unit	
	Remote control	
Remote control	Ch1	P98
	Ch2	
	Ch3	
	Ch4	
	Independent *	
Language	English	P99
	German	
	French	
	Italian	
	Spanish	
	Portuguese	
	Swedish	
	Russian	
	Dutch	
	Finnish	
	Norwegian	
	Turkish	
	Polish	
	Hungarian	
	Czech	
	Danish	
	Arabic	
	Chinese (Simplified)	
	Chinese (Traditional)	
	Korean	
	Japanese	
Guide	Off	P99
	On *	
Show Input Status	Off	P100
	On *	
HDMI In	Auto *	P100
	Computer	
Other settings		
Password settings	Off *	P101
	On	
Register password	Password input	P102
Lens Ctrl Lock	Off *	P102
	On	
Lens shift Reset	Lens shift Reset	P103
Menu display time	Normal *	P103
	Extended	
Overheat Warning Display	Off *	P104
	On	
Deflicker	Off *	P104
	Adjust	
Lamp counter	Return	P105
	Reset (OK/Cancel)	
Factory defaults	OK/Cancel	P107
Return		

Network Setting Menu

Network setting lock	Unlock	P135
	Lock *	
Network function	Off *	P136
	On	
Network Password setting	Off	P136
	On *	
Register Network Password	Password input	P137
PJLink	Off	P137
	On *	
DHCP	Off *	P138
	On	
TCP/IP settings	IP address	P139
	Subnet mask	
	Gateway address	
	Enter	
Network setting initialization	Yes/No	P139

Information Menu

Model name	P108
Input signal	
Firmware	
Serial No.	
IP address	
Gateway address	
E-mail sender address	
E-mail recipient address	
Projector name	
Location	
System information ID	

*: Factory defaults (setting after reset)

**CANON INC.**

30-2, Shimomaruko 3-chome, Ohta-ku, Tokyo
146-8501, Japan

U.S.A.

CANON U.S.A. INC.

One Canon Plaza, Lake Success, NY 11042-
1198, U.S.A.

For all inquires concerning this product, call toll
free in the U.S. 1-800-OK-CANON

CANADA

CANON CANADA INC. HEADQUARTERS

6390 Dixie Road, Mississauga, Ontario L5T
1P7, Canada

CANON CANADA INC. MONTREAL BRANCH

5990, Côte-de-Liesse, Montréal Québec H4T
1V7, Canada

CANON CANADA INC. CALGARY OFFICE

2828, 16th Street, N.E. Calgary, Alberta T2E
7K7, Canada

For all inquiries concerning this product, call toll
free in Canada

1-800-OK-CANON

EUROPE, AFRICA & MIDDLE EAST

CANON EUROPE LTD.

3 The Square Stockley Park, Uxbridge, Middle-
sex, UB11 1ET United Kingdom

CANON EUROPA N.V.

Bovenkerkerweg 59-61, 1185 XB Amstelveen,
The Netherlands

CANON FRANCE S.A.S

17, quai du President Paul Doumer, 92414
Courbevoie Cedex, France

CANON UK LTD.

Woodhatch Reigate Surrey RH2 8BF, United
Kingdom

CANON DEUTSCHLAND GmbH

Europark Fichtenhain A10, 47807 Krefeld, Ger-
many

CANON ITALIA S.p.A.

Via Milano 8 I-20097 San Donato Milanese, Mil-
ano, Italy

CANON Schweiz AG

Geschäftsbereich Wiederverkauf, Industri-
estrasse 12, CH-8305 Dietlikon,
Switzerland

CANON GMBH

Zetschegasse 11, A-1230 Wien, Austria

CANON España, S.A.

C/Joaquin Costa, 41, 28002 Madrid, Spain

CANON PORTUGAL S.A.

Rua Alfredo da Silva, 14 Alfragide 2610-016
Amadora, Portugal

CANON Belgium N.V./S.A.

Berkenlaan 3, 1831 Diegem (Mechelen), Bel-
gium

CANON Netherland NV

Neptunusstraat 1, 2132 JA Hoofddorp, The
Netherlands

CANON LUXEMBOURG S.A.

Rue des Joncs 21, L-1818 Howald, Luxem-
bourg

CANON DANMARK A/S

Knud Hoejgaards Vej 1 DK-2860 Soeborg, Dan-
mark

CANON OY

Huopalahdentie 24 PL 1 00351 Helsinki, Fin-
land

CANON SVENSKA AB

Gustav III:s Boulevard 26 169 88 Solna, Swe-
den

CANON NORGE as

Hallagerbakken 110, Postboks 33, Holmlia,
1201 Oslo, Norway

CENTRAL & SOUTH AMERICA

CANON LATIN AMERICA, INC.

703 Waterford Way, Ste. 400 Miami, FL 33126,
U.S.A.

ASIA

CANON (China) Co., Ltd.

15F Jinbao Building No.89 Jinbao Street,
Dongcheng District, Beijing 100005, China

CANON HONGKONG CO., LTD.

19/F., The Metropolis Tower, 10 Metropolis
Drive, Hungghom, Kowloon, Hong Kong

CANON SINGAPORE PTE. LTD.

1 HarbourFront Avenue, #04-01 Keppel Bay
Tower, Singapore 098632

CANON KOREA CONSUMER IMAGING INC.

Gangnam Finance Center 17F,737, Yeoksam-
Dong, Gangnam-gu, Seoul, 135-984, Korea

OCEANIA

CANON AUSTRALIA PTY. LTD.

1 Thomas Holt Drive, North Ryde, N.S.W. 2113,
Australia

CANON NEW ZEALAND LTD.

Akoranga Business Park, Akoranga Drive,
Northcote, Auckland, New Zealand