



KUNDE HEALTHCARE SERVICES®

Tel: (262) 370-4556
kundehalo@gmail.com
kundehealthcareservices.com

Kunde Healthcare Services, Inc.
P.O. BOX 325 | Oconomowoc, WI 53066

HALO SAFETY RING - WARNINGS

- ⚠ WARNING!** The Halo Safety Ring must only be used with bed systems that are reset to the manufacturer's original specifications and that have been individually tested. Do not assume all bed systems in your facility are the same or set to manufacturer's original specifications. Each bed system must be tested and measured individually. Bed systems should be evaluated, measured, and tested by your assessment team.

- ⚠ WARNING!** Improper assessment of the bed system and failure to evaluate the specific needs of each resident will prevent a correct bed system measurement device evaluation of certain entrapment zones. This improper assessment could lead to the possibility of injury or death. Each resident must be evaluated individually. To qualify for the Halo Safety Ring, a bed system must first meet the following standards:
 1. Mattress height must be between 6 and 7 inches.
 2. Mattress width must be 36, 37, or 38 inches.
 3. Only high-quality mattresses should be used to ensure a proper weight to compressibility factor.
 4. The mattresses used must be the proper length and width per the bed frame manufacturer's standards.

- ⚠ WARNING!** Mattress compression and gap space creation is the uncontrollable factor in the failure of bed systems. Resident must be assessed based on body type i.e. height, weight, girth, etc. Continuous movement in bed increases compression, gap spaces, and the possibility of injury or death.

- ⚠ WARNING!** If you improperly measure, assess, or test a resident or his or her bed system, the Halo Safety Ring may not provide adequate protection. If the Halo Safety Ring is installed improperly, it may not provide the intended entrapment protection.

- ⚠ WARNING!** Bed systems and each resident should be reevaluated periodically to ensure that the system still provides the resident adequate entrapment protection. Proper patient assessment and monitoring, and proper maintenance and use of equipment is required to reduce the risk of entrapment. Variations in mattress thickness, size or density could increase the risk of entrapment. Visit the FDA website at www.fda.gov to learn about the risks of entrapment.

- ⚠ WARNING!** Bed system assessments should be conducted within the context of, and in compliance with, state and federal guidelines related to the use of restraints and bed system entrapment guidance, including the Clinical Guidance for the Assessment and Implementation of Side Rails published by the Hospital Bed Safety Workgroup of the U.S. Food and Drug Administration. Further information can be obtained at: www.fda.gov by searching for HBSW.



KUNDE HEALTHCARE SERVICES®

Tel: (262) 370-4556
 kundehalo@gmail.com
 kundehealthcareservices.com

Kunde Healthcare Services, Inc.
 P.O. BOX 325 | Oconomowoc, WI 53066

HALO SAFETY RING

MODEL: 77301 - SINGLE SIDED MOUNT WITH CIRCLE MOUNTING BRACKET MOUNT

MODEL: 77302 - DOUBLE SIDED MOUNT WITH CIRCLE MOUNTING BRACKET MOUNT

Product Number 77302 comes with same items as Product Number 77301 except one extra Halo Safety Ring Circle (77104)

PARTS INCLUDED

ITEM	QTY	DESCRIPTION
1	1 or 2	Halo Safety Ring Circle
2	2	Halo Safety Ring C/Channel Circle Mounting Brackets
3	1	Halo Safety Ring, Straight Tube with Width Adjusting Holes
4	2	Halo Safety Ring, Contoured Tubes
5	2	Detent Pin

ITEM	QTY	DESCRIPTION
6	2	Rubber Tube Separator
-	1	Hardware Kit for Both the Halo Safety Ring Single Circle (77301) and Halo Safety Ring Double Circle Unit Product Number (77302)
7	2	Screw - M8 x 1.25 x 55mm, SHCS, Zinc
8	2	M8 Split Washer, Zinc
9	2	Screw - M5 x .8 x 14mm, SHCS, Zinc
10	2	M5 Split Washer, Zinc
11	4	Screw - M8 x 1.25 x 40mm, SHCS, Zinc, Nail-Like Tip
12	4	Screw - M8 x 1.25 x 65mm, SHCS, Zinc (Not Shown)
13	1	6mm T Shape Allen Wrench (Not Shown)
14	1	3mm L Shape Allen Wrench (Not Shown)
15	1	3/4 x 10" Dowel
16	1	8" Detent Pin Remover

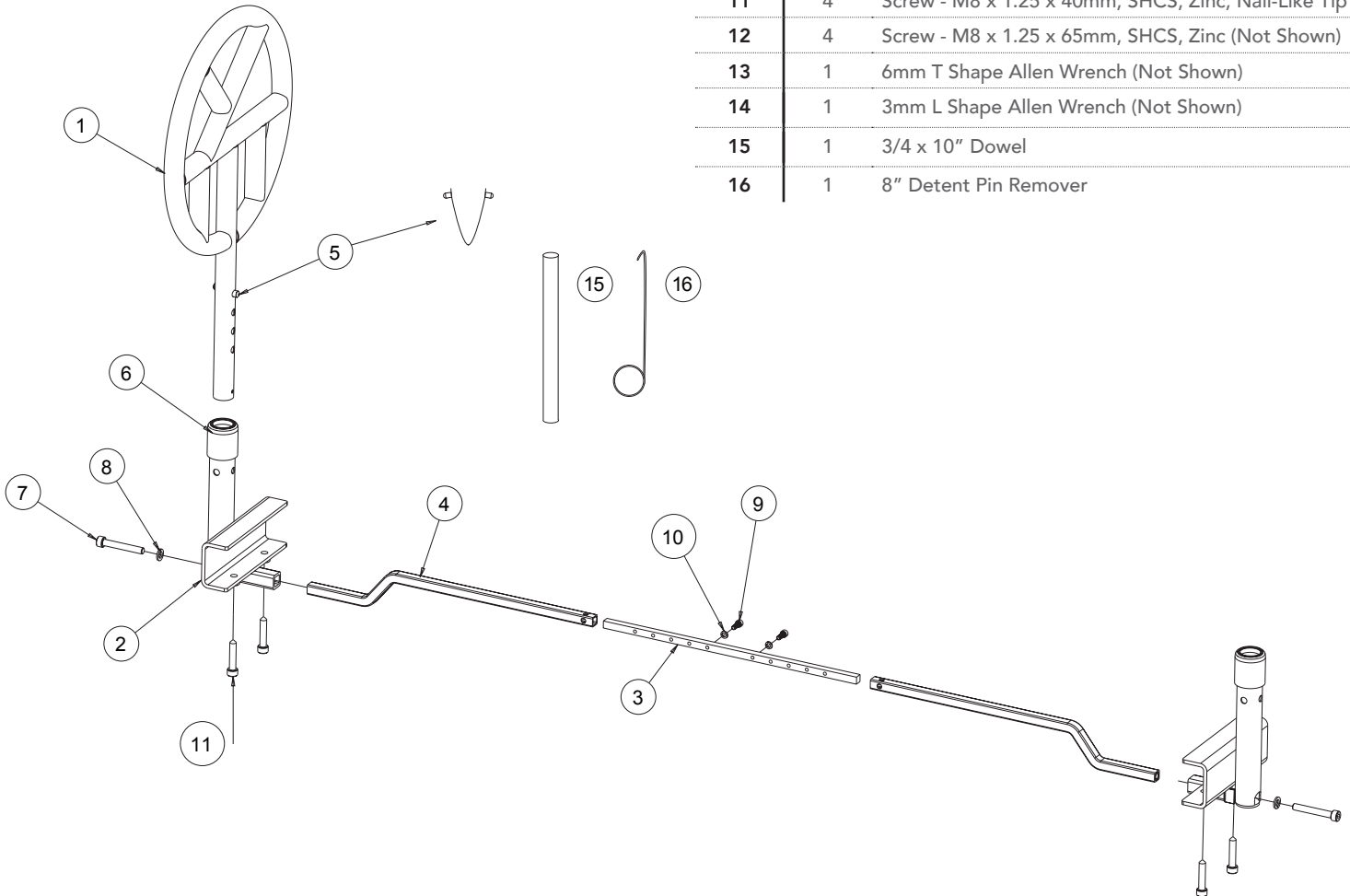

HALO SAFETY RING - Installation Instructions

MODEL: 77301
 MODEL: 77302

Go to kundehealthcareservices.com to view installation and testing video.

1

With the mattress removed, measure the bedframe's width. Attach both Item 4 to Item 3 using Items 9 and 10. Use the chart below to determine which setting is appropriate. If the bedframe width straddles two categories, use the narrowest possible setting the bedframe will allow.

ACTUAL BED FRAME WIDTH:

- WIDTH A = 34" < 36"
- WIDTH B = 36" < 38"
- WIDTH C = 38" < 40"
- WIDTH D = 40" < 42"
- WIDTH E = 42" < 44"

⚠ WARNING! *If your facility uses multiple bed systems, each system must be measured and evaluated separately. All bed systems must be reset to manufacturer's specifications and tested individually. Do not assume all bed systems in your facility are the same.*

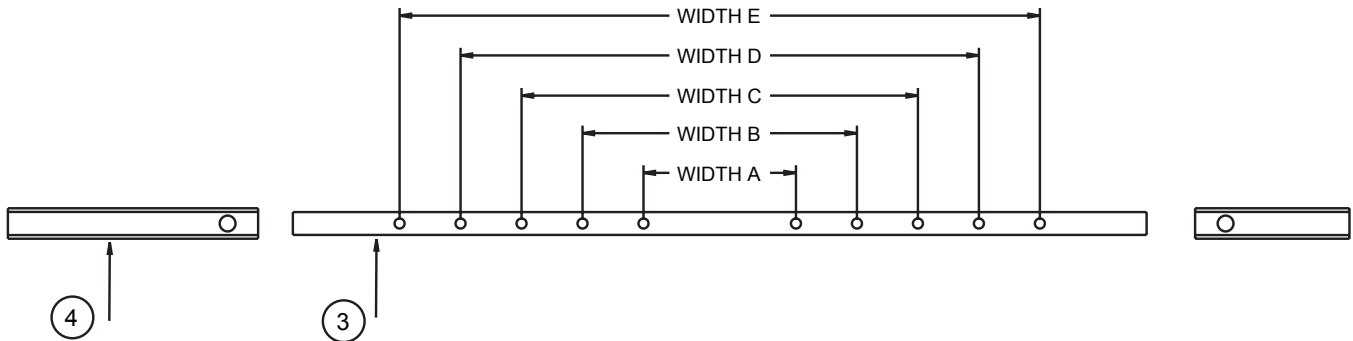

2

Place the combined Items 4 and 3 approximately 6 to 12 inches above the crease between the head and lower portion of the bed. Attach an Item 2 to Item 4 using Items 7 and 8, but do not fully tighten. Place the first Item 2 over the side of the bed that raises the head up and down.

⚠ WARNING! *Mattress compression and gap space creation is the uncontrollable factor in the failure of bed systems. Resident must be assessed based on body type i.e. height, weight, girth, etc. Continuous movement in bed increases compression, increases gap spaces, and the possibility of injury or death.*

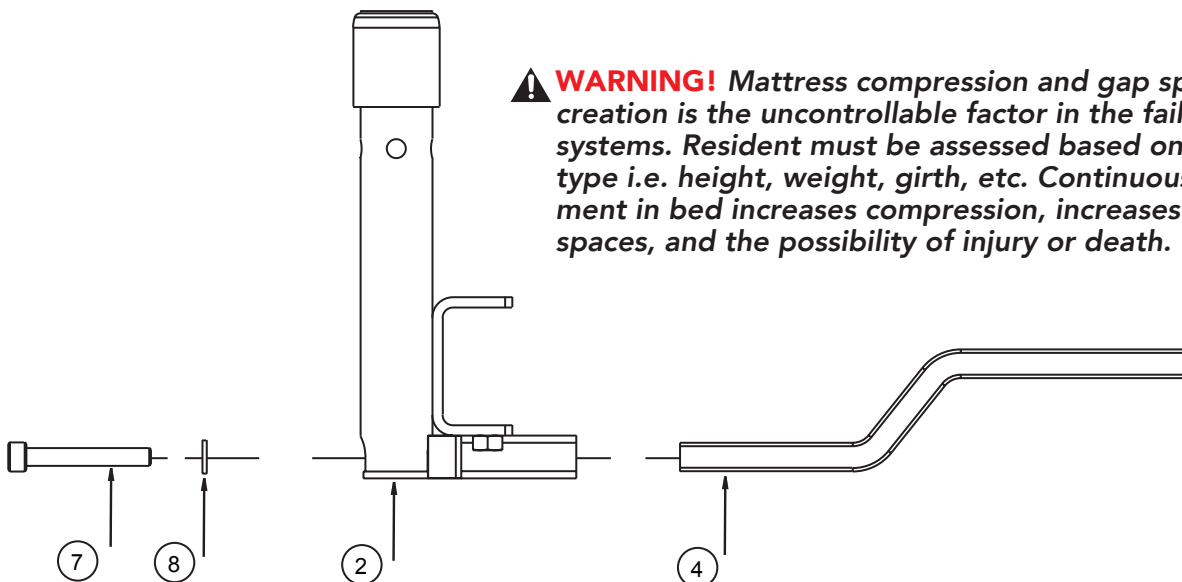

HALO SAFETY RING - Installation Instructions

MODEL: 77301
 MODEL: 77302

3 Repeat Step 2 again on the opposite side of the bed. Then tighten Item 7 on both sides of the bed evenly.

Note: *The Halo Safety Ring moves up and down with the head portion that raises the head up and down. It does not connect to the main frame.*

⚠ WARNING! *If you improperly measure, assess, or test a resident or his or her bed system, the Halo Safety Ring may not provide adequate protection. If the Halo Safety is installed improperly, it may not provide the intended entrapment protection.*

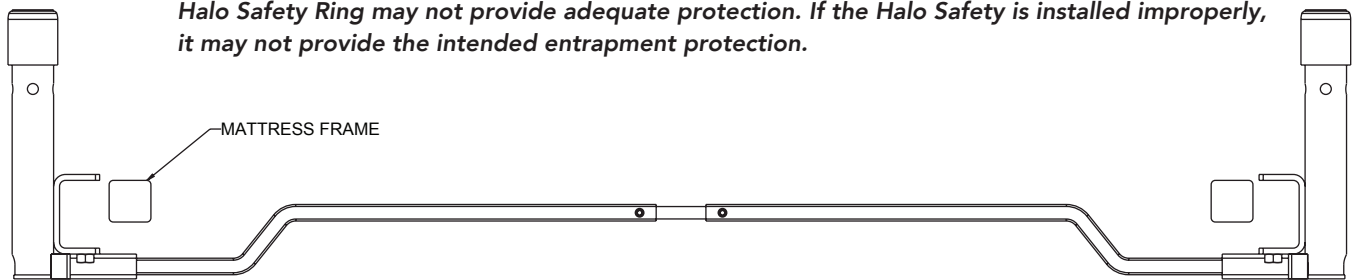

4 Once the Halo Safety Ring Bracket system is safely installed, attach two Item 11's to Item 2 on each side of the bed. Tighten Item 11's so they dig into the bed frame to secure the Halo Safety Ring system into place.

Note: *If the bed has an L-shaped steel frame, use Item 12 instead of Item 11.*

⚠ WARNING! EXAMPLE! *The mattresses used must be the proper length and width per bed frame manufacturer standards.*

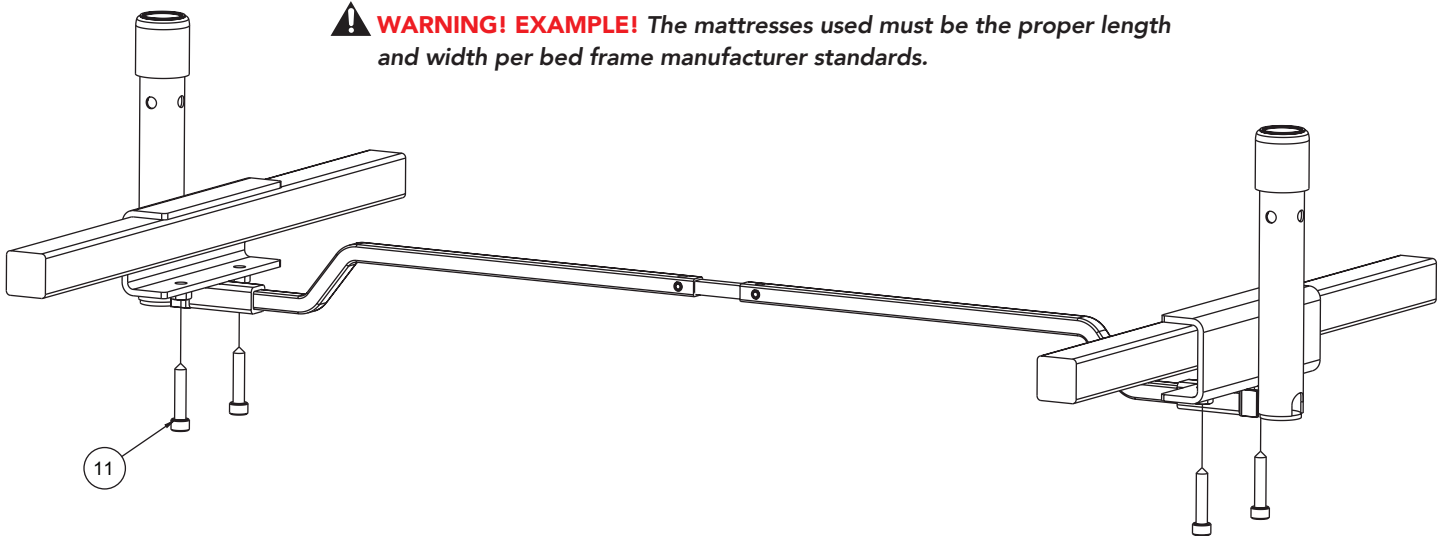

You are now ready to install the Halo Safety Ring(s) (77104) into the Circle Mounting Bracket(s) (77305) and test the various entrapment zones.

- WARNING -

Mattress must remain in firm contact with the Halo Safety Ring on both sides of the bed. If a Halo Safety Ring is only installed on one side of the bed, the mattress must remain in firm contact with the mattress stay or mount bracket on the other side of the bed. In order to prevent entrapment in Zones 1 through 4 and create a protective sleep environment, two complete Halo Safety Ring Brackets must be installed on the same bed.

HALO SAFETY RING - Installation Instructions

MODEL: 77301
MODEL: 77302

NOTE: The Halo Safety Ring is adjustable in height to accommodate different thicknesses and compression of various mattresses. If the Halo Safety Ring fails a test for Zone 4, you will need to adjust its height. To do this, remove Detent Pin using the Detent Pin Remover and reinstall to proper hole using a wooden dowel. By testing the unit for Zone 4 and adjusting the Detent Pin to allow the cylinder to go freely under the circle, the measurement device will then show a PASS for Zone 4. Follow instructions below to adjust height.

5 To remove Detent Pin, use Detent Pin Remover tool by inserting into tube with hook facing up towards the holes. While squeezing pins, turn the hook to catch the pins and pull gently past each hole.

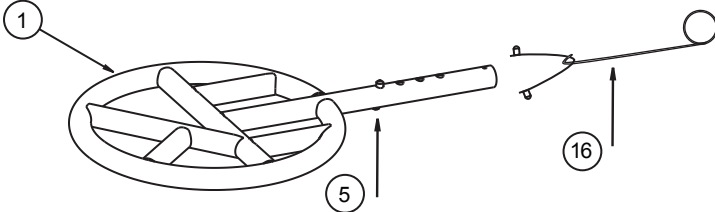

6 To insert Detent Pin, squeeze pins and insert with pins facing holes. Use Dowel tool to push detent pin up into the tube to the correct hole. Squeezing pins past each hole that is not being used.

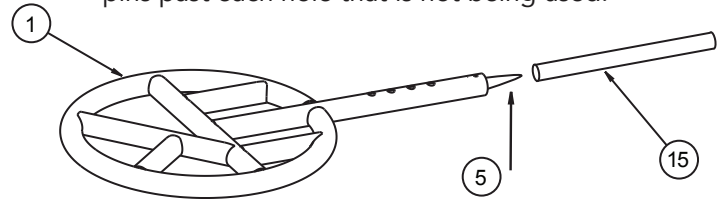

- WARNING -

- Serious injury or death can result if the Halo Safety Ring is not properly installed.
- DO NOT use this product or any available optional equipment without first completely reading & understanding these instructions. If you are unable to understand the warnings, cautions or instructions, contact customer service at (262) 370-4556 for assistance before attempting to use this equipment - otherwise, injury or damage may occur.
- The Halo Safety Ring is not intended to prevent an individual from inadvertently rolling out of bed. DO NOT use the Halo Safety Ring for restraint purposes. DO NOT use to transport or move bed.
- ENTRAPMENT MAY OCCUR. Proper patient assessment and monitoring, and proper maintenance and use of equipment is required to reduce the risk of entrapment. Variations in mattress thickness, size or density could increase the risk of entrapment. Visit the FDA website at <http://www.fda.gov> to learn about the risks of entrapment.
- Remove bed rails and all bed rail mounting brackets prior to installation of the Halo Safety Ring.
- The Halo Safety Ring is rated for use with patients weighing up to 1000 lbs. Although the Halo Safety Ring is rated for such use, it may become deformed or broken if excessive force is exerted on the device.
- After installation, verify the mattress is in firm contact with the Halo Safety Ring and that the mattress cannot shift away.
- Detent pins used to rotate the Halo Safety Ring must be engaged with holes in the Halo Bracket prior to use, refer to Figure 1.
- The Halo Safety Ring must be perpendicular (90°) to the bed if used to assist the user out of a chair. Detent pins must be engaged with the holes in the Halo Safety Ring bracket prior to use as a patient assist.



WARNING!
IMPROPER INSTALLATION CREATES A RISK OF ENTRAPMENT

In order to avoid entrapment, the mattress must remain in firm contact with the Halo Safety Ring on both sides of the bed. If a Halo Safety Ring is only installed on one side of the bed, the mattress must also remain in firm contact with the mattress stay/bracket on the other side of the bed.



HALO SAFETY RING - Rotation Instructions

MODEL: 77301
 MODEL: 77302

INSTRUCTIONS FOR USE

The Halo Safety Ring can be grasped by the resident to assist in bed mobility. This can help build strength, increase independence, and help prevent skin breakdown.

The Halo Safety Ring is designed to rotate ninety degrees (90°) to assist residents during transfers and as a bed mobility device. Follow the steps for safely rotating the Halo Safety Ring.

- 1** In order to rotate the Halo Safety Ring, pinch the detent pins and rotate the Halo Safety Ring ninety degree (90°) as shown below.
- 2** Detent pins must engage with the holes in Halo Safety Ring bracket prior to use.
- 3** Always position the Halo Safety Ring parallel with the bed when in use and make sure detent pins are engaged.

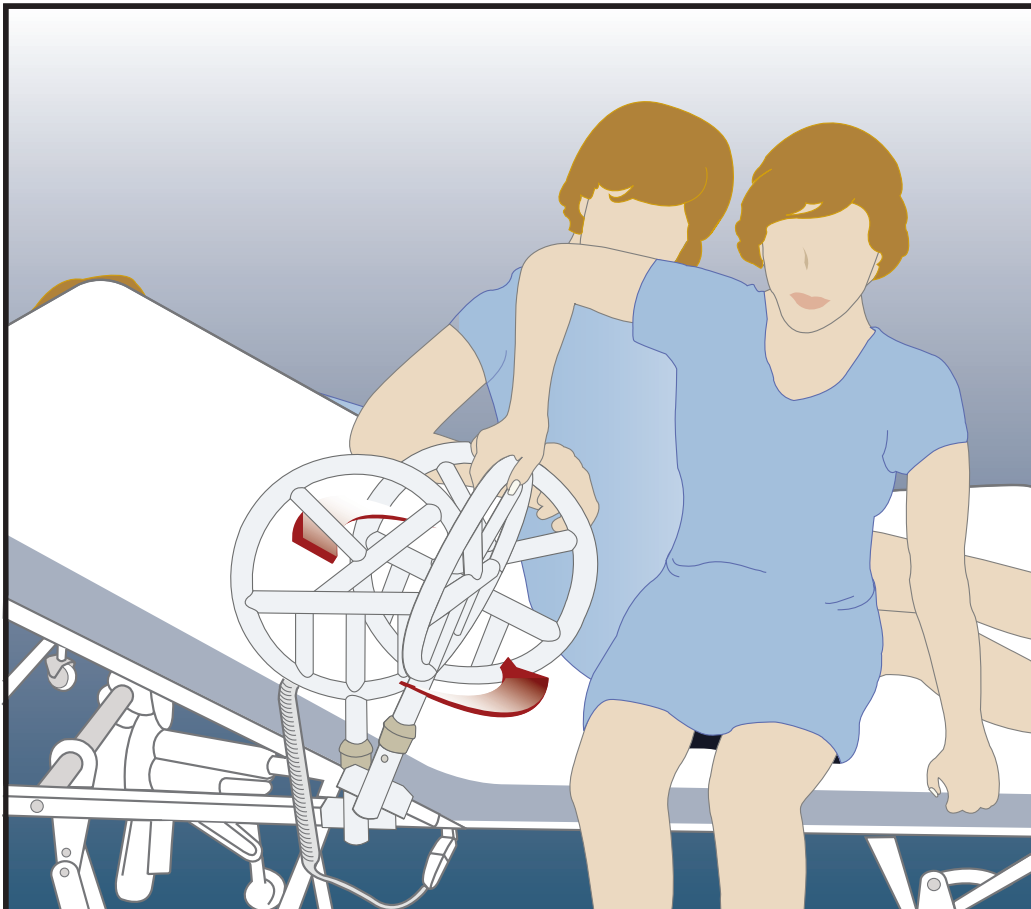

SAFETY PRECAUTIONS:

- Regularly check the Halo device to identify areas of possible entrapment. Immediately cease using the bed if entrapment risk exists.
- Regularly check to make sure that there is no gap between the Halo Safety Ring and the side of the mattress. A gap could allow entrapment between the bed rail and the mattress.
- Follow all assembly instructions carefully. Failure to follow the instructions could result in serious injury to the user(s) of the product.

- WARNING -

Failure to return the Halo Safety Ring to a parallel position when the bed is in use may cause entrapment hazard.