

**ATU 8/2016**

# Important Reminder

**This information is supplemental only.**

- > There may be information in this presentation that is not necessarily relevant to the North American market.
- > Always refer to ELSA for the latest repair information
- > Check for any Knowledge Articles in A.U.D.I. Search
- > Check for any open campaigns or RVU's
- > Check for the latest TSB's
- > Always check ETKA for the correct part numbers

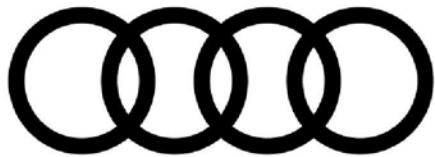

**Running gear: Audi magnetic ride – knocking noises from rear shocks on S3(8V) and TTS(FV)**

# Audi magnetic ride – knocking noises from rear shocks

## Operating principle

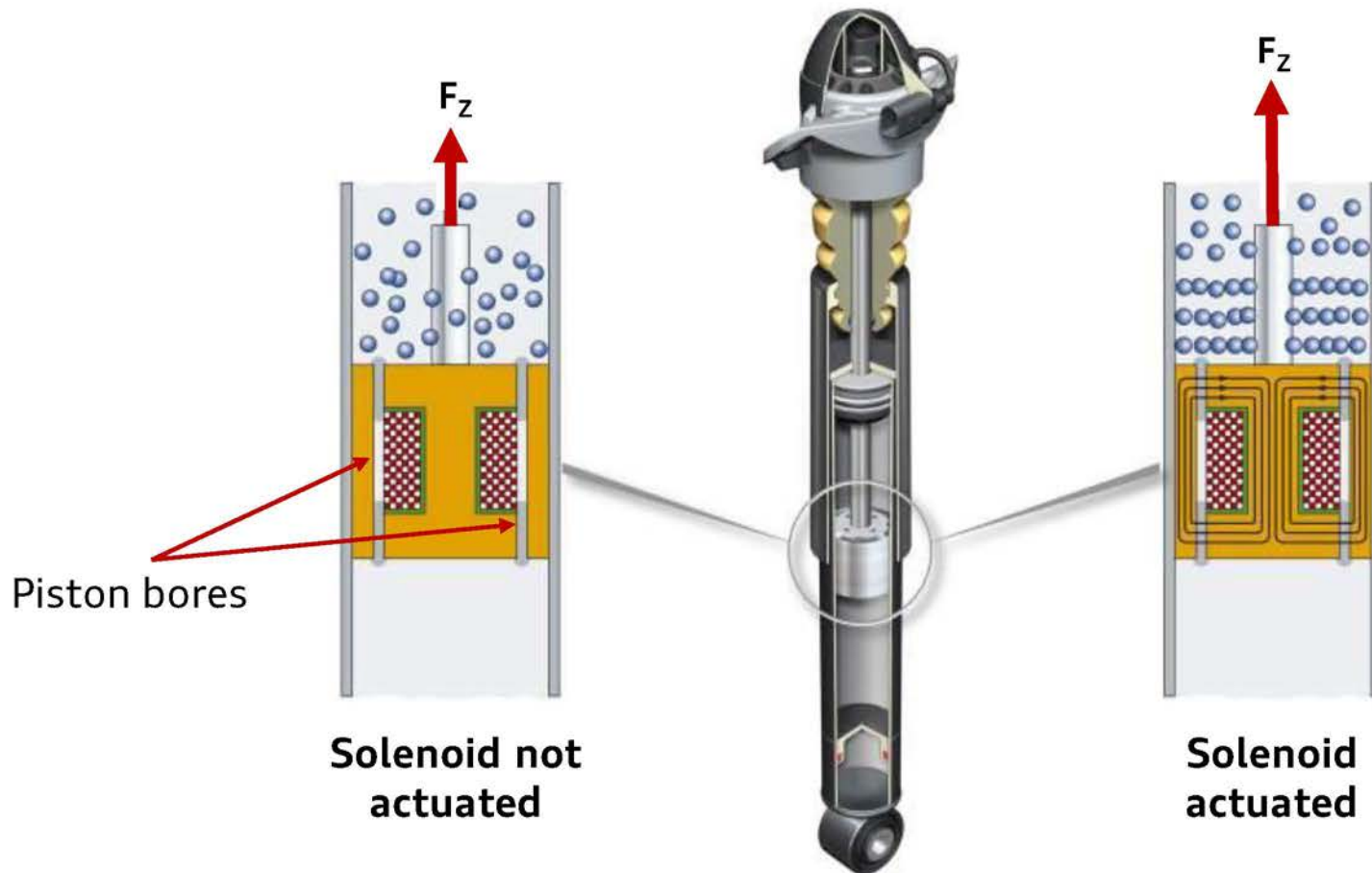

- » The shock absorbing dampening is adjusted by changing the input current and the resulting magnetic field

# Audi magnetic ride – knocking noises from rear shocks

## Current Customer Complaint

- › Complaint Knocking noises coming from the back of the car when driving over bumps or on uneven roads.
- › Measure Change the rear shock absorber mounting.
- › Part number: 8S0 513 353 to 8V0 513 353



- › Note Only perform this repair if the vehicle was originally equipped with part number 8S0 513 353.

- › TSBs  
2042645 S3 (8V)  
2042539 TTS (FV)

- ›› The TSBs listed above are only applicable to vehicles equipped with the Audi magnetic ride suspension and were built with part 8S0 513 353.

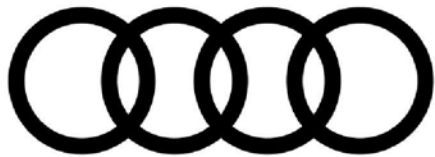

## **Brake System: Braking noises – basic principles for diagnosis and repair**

# Braking noises – basic principles and countermeasures

## Agenda

**1** Basics

---

**2** Countermeasures for squeaking noises

---

**3** Countermeasures for rattling noises and clicking when reversing

---

**4** Summary – tips for practical use



# Braking noises – basic principles and countermeasures

## Basics

The purpose of the brake system is to reliably and comfortably slow the vehicle and to fully brake the vehicle in an emergency, with the shortest possible braking path and while retaining the stability of the driving dynamics. Despite continual efforts in brake development to satisfy all requirements, the brake can generate some annoying noises. The generation of these noises depends on a variety of influencing factors, which must be noted in particular when attempting to reproduce the noise.

### **Environmental conditions:**

- › Climate: dry, wet, warm, cold, snow
- › Road condition: weather-dependent (e.g. road salt), construction-related (e.g. cobblestones)

### **Operating conditions:**

- › Brake temperature
- › Speed
- › Brake pressure
- › Vehicle tires (wheel rim design)



# Braking noises – basic principles and countermeasures

## Basics

- › Noise incidents are normally classified according to frequency band and mechanism of excitation
- › Classification of vibrations when braking:

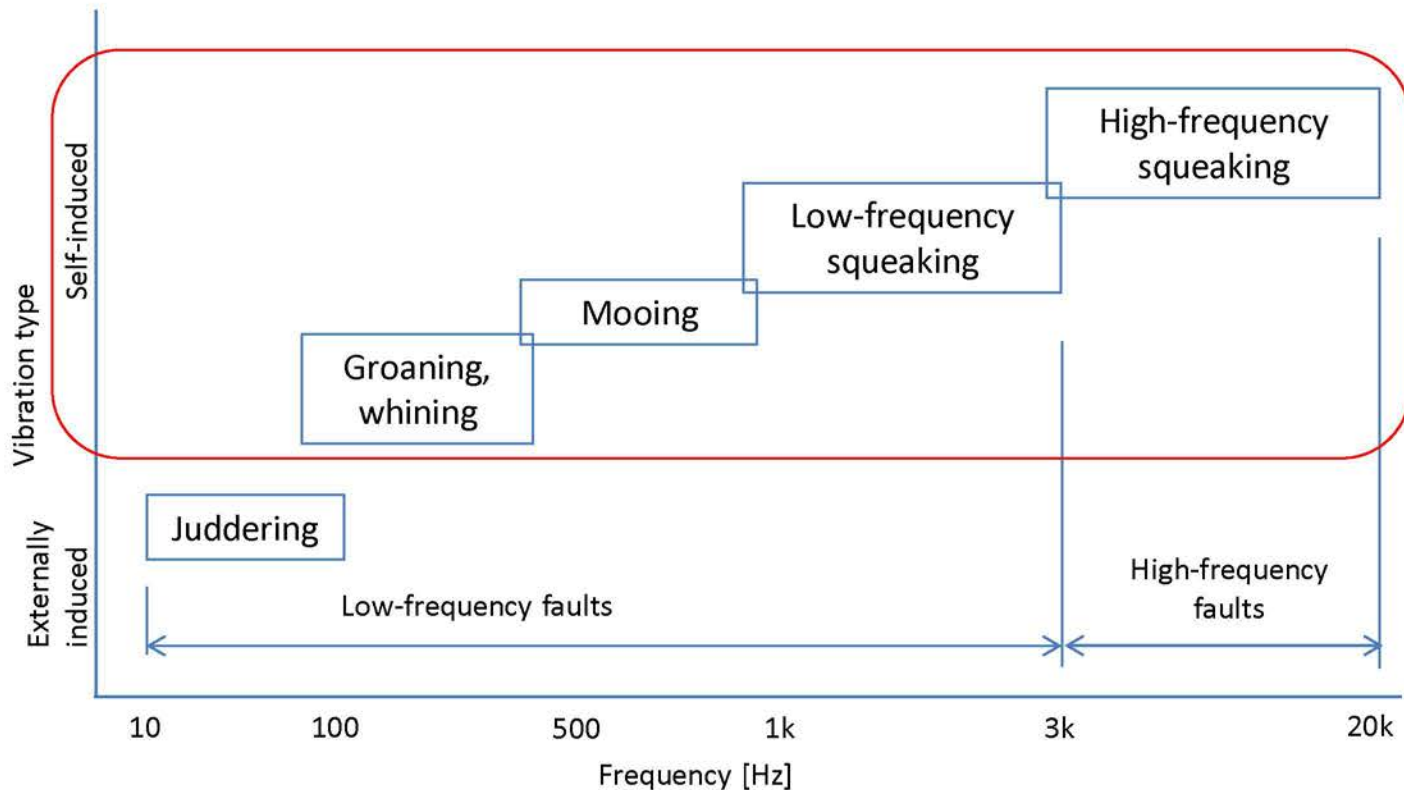

# Braking noises – basic principles and countermeasures

## Countermeasures for squeaking noises

### > Damper/shim plates



- > Damper plates, or "shims" may be attached to the backplates of the brake pads.
- > These vary in shape and material and are sometimes unidirectional.
- > Relevant disc brake pads are marked with an arrow that indicates the direction of rotation of the brake disc when driving forwards.

# Braking noises – basic principles and countermeasures

## Countermeasures for squeaking noises

### > Adjusting the brake pad (chamfer)

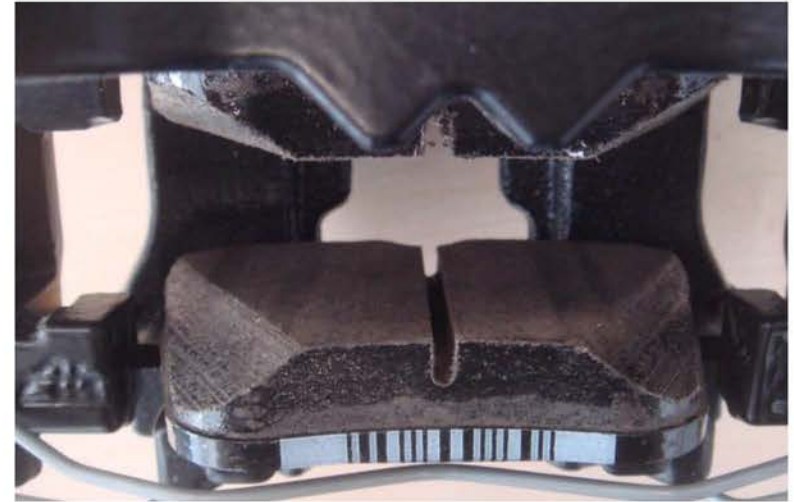
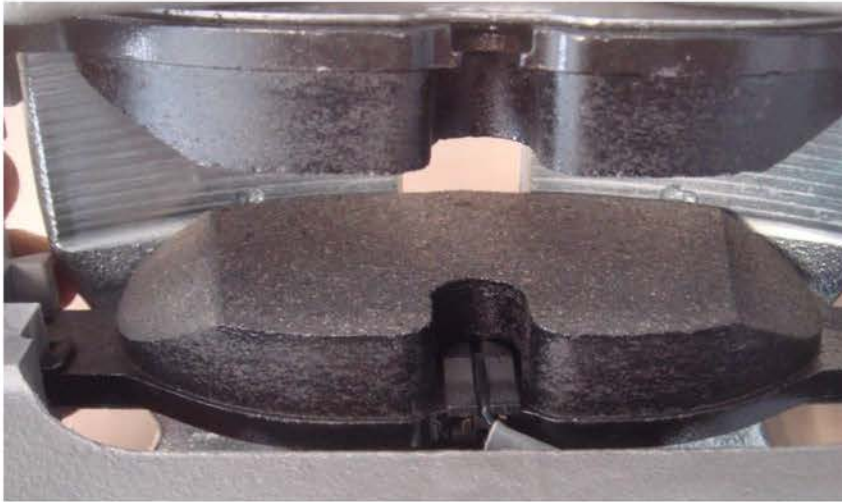

- > Chamfers on the brake pad material ensure that the pad is not pressed evenly on the brake disc

# Braking noises – basic principles and countermeasures

## Countermeasures for squeaking noises

### › Active vibration dampers



- › Vibration damper vibrates out of phase with the disruptive excitation.
- › An elastomer supporting body performs the damping function.
- › Series use, e.g., RS models.



# Braking noises – basic principles and countermeasures

## Countermeasures for squeaking noises

### › Passive vibration dampers



- › Natural frequency is offset due to passive components in the brake system.
- › Vibration dampers are delivered together with the brake caliper/brake pad and are not intended for subsequent installation.
- › Series use, e.g., S6,S7, S8, R8.

# Braking noises – basic principles and countermeasures

## Countermeasures for rattling and clicking when reversing

### > Spring mounting for brake caliper



- > Rattling noises and clicking on the brake when reversing are caused by relative movements of the brake pad in the brake caliper guides. This is usually due to defective or missing spring elements.

# Braking noises – basic principles and countermeasures

## Summary – tips for practical use

- » Before performing repair work for braking noises, a frequency analysis must be performed and the above environmental and operating conditions must be noted.
- » Precise determination of the source of the noise (front axle/rear axle, right-side/left-side).
- » Perform repairs exactly as described in the workshop manual or TSB.
- » Brake pads must never be reworked. Manual reworking of the brake pads, such as grinding or filing, leads to a reduction of the friction surface and causes mechanical and thermal overload. The effectiveness of the brake is reduced and wear and noises are increased.
- » Always check pads/discs for unidirectional markings prior to installation.



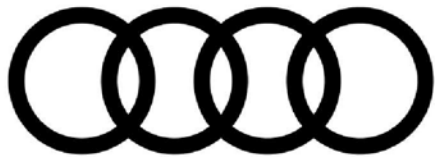

**Running gear: Multi-collision brake**

# Multi-collision brake

## Agenda

**1** Mode of operation of the multi-collision brake

---

**2** Use at Audi

---

**3** Procedure at the dealer

# Multi-collision brake

## Mode of operation of the multi-collision brake

- › Studies have shown that in the event of an accident, the first collision is often immediately followed by a second collision, either with a vehicle in front, another road user, or with obstacles such as crash barriers or trees.
- › This is where the multi-collision brake intervenes: the multi-collision brake is activated when two independent sensors detect an accident.
- › The airbag control unit then issues a command to the ABS/ESC control unit to brake the vehicle. After an accident, the vehicle continues to brake independently, even if the driver no longer actuates the brake pedal. This prevents what could otherwise be a second collision, or reduces the impact energy of a subsequent collision due to the reduced speed. The reduced speed also makes the vehicle easier to control.
- › The driver can retake control of the vehicle at any time.
- › In the owner's manual, this function is referred to as the "Automatic Post-Collision Braking System".

## Multi-collision brake

### Mode of operation of the multi-collision brake

- › Accident situations in which the multi-collision brake enters into effect:

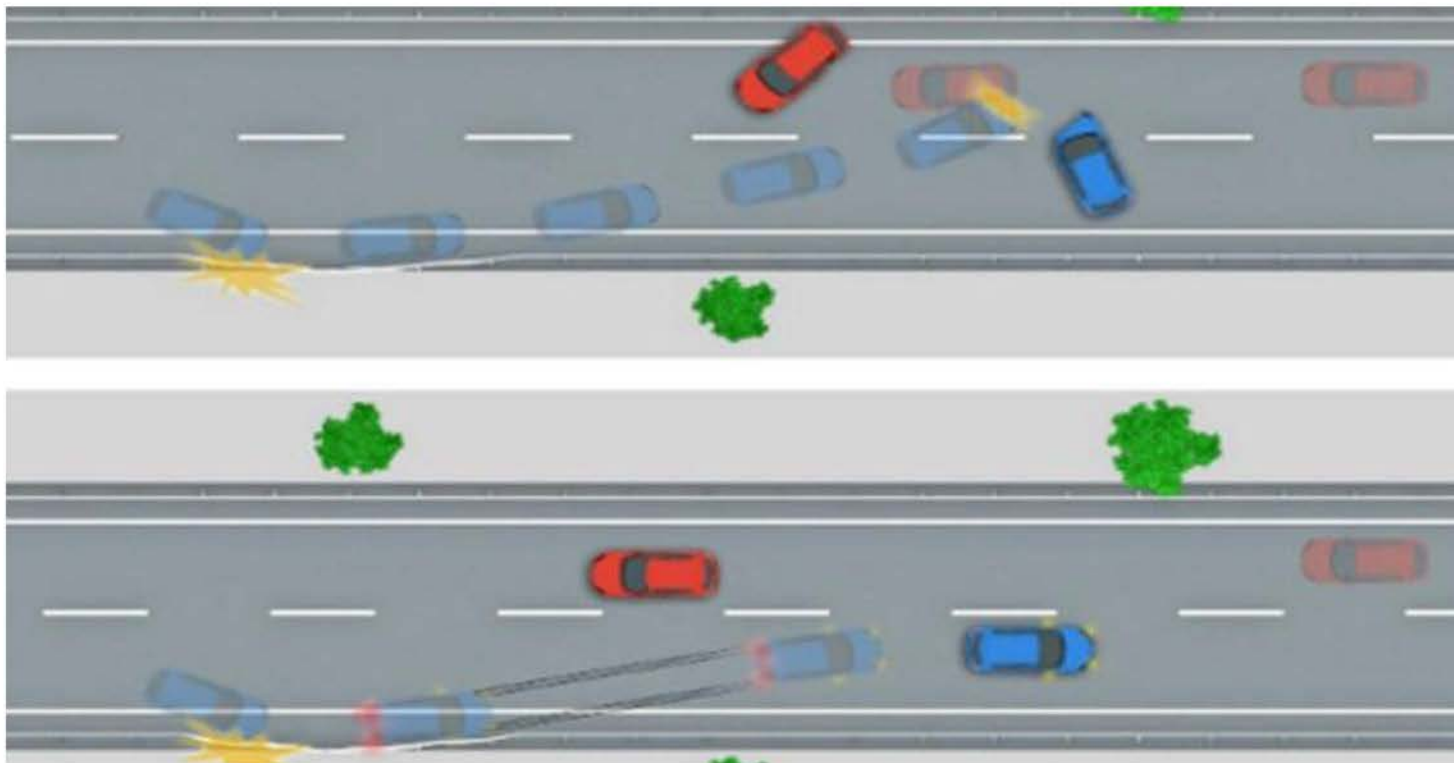

- » The multi-collision brake **can prevent** the vehicle from swerving into oncoming traffic after colliding with the crash barrier.

## Multi-collision brake

### Mode of operation of the multi-collision brake

- › Accident situations in which the multi-collision brake enters into effect:

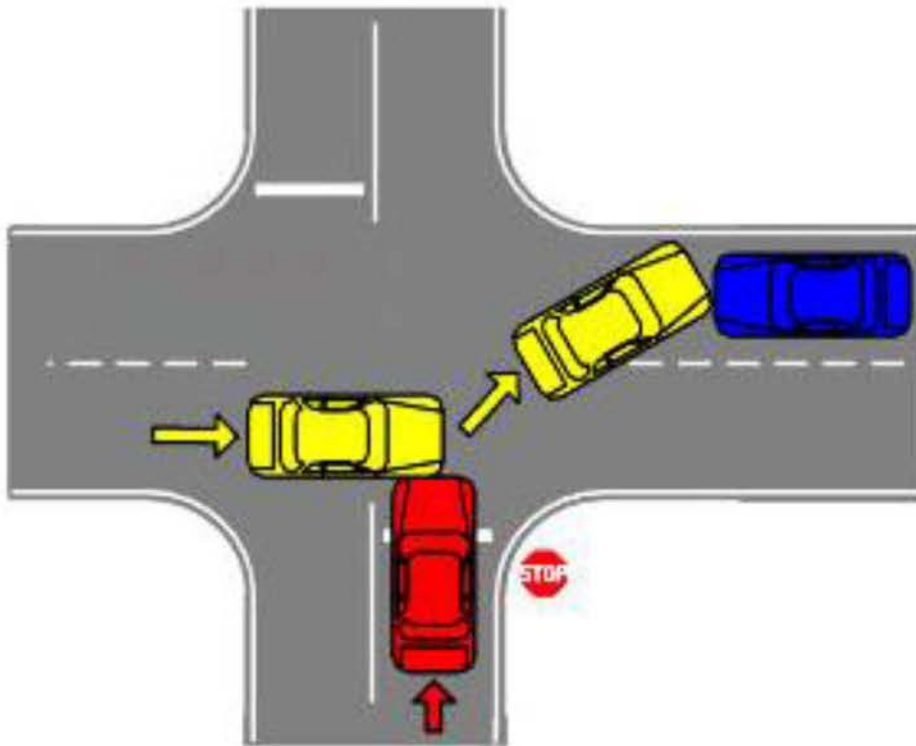

- » The multi-collision brake **can prevent** the rammed vehicle from being shunted into the oncoming lane.

## Multi-collision brake

### Mode of operation of the multi-collision brake

- › Accident situations in which the multi-collision brake enters into effect:

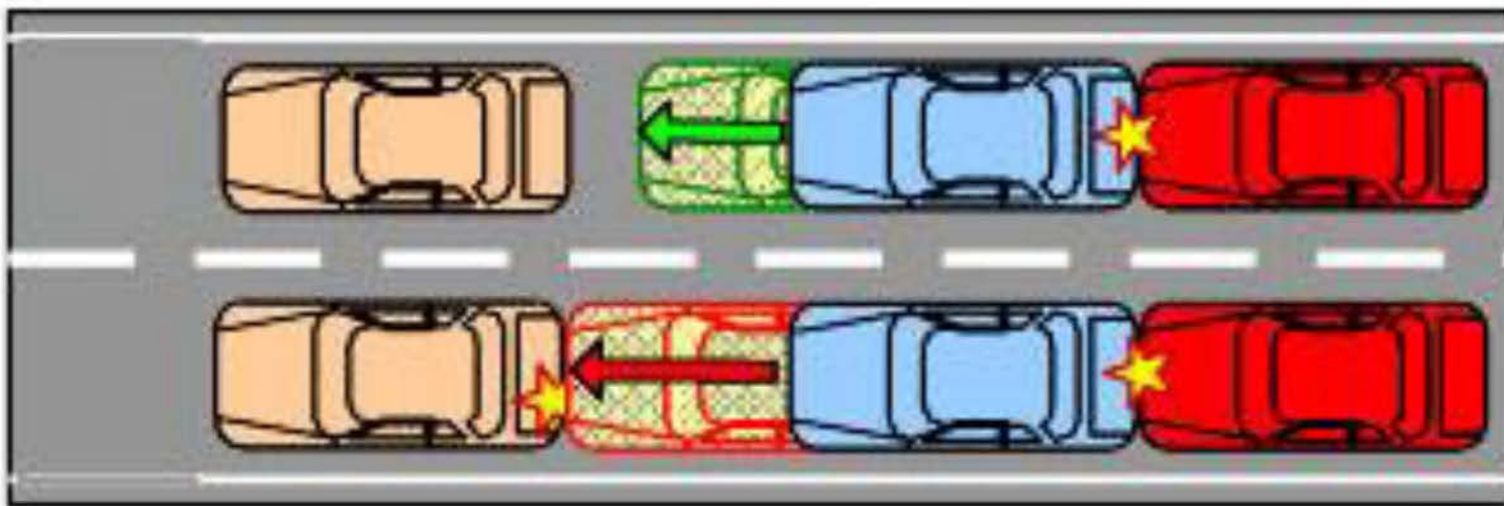

- ›› The multi-collision brake **can prevent** the rammed vehicle from being shunted into the vehicle in front.

# Multi-collision brake

## Use at Audi

- › **The multi-collision brake has been implemented:**
  - › In the A3 since the launch of the last model (model year 2013).
  - › In the TT since the launch of the last model (model year 2015).
  - › In the A4 since the launch of the new model (model year 2016).
  - › In the A6 and A7 since model year 2015.
  - › In the A8 since model year 2015.
  - › In the Q7 since the launch of the new model (model year 2017).
  - › In the R8 since the launch of the new model (model year 2017).



# Multi-collision brake

## Procedure at the dealer

- › The function of the multi-collision brake is performed by the ESC. This function is therefore only available if the ESC is working correctly.
- › In the event of a fault in the ESC, the multi-collision brake is also deactivated, and the yellow airbag warning lamp is also actuated in addition to the ESC warning lamp.
- › The entry "B13BCF2 multi-collision brake no function" will be added to the event memory in the airbag control unit after the ESC is switched off.
- › The cause of the ESC deactivation must first be resolved; otherwise, the multi-collision brake cannot be activated. The cause of an ESC deactivation is not always due to a fault on the ABS/ESC itself. The ESC can also switch off because of a malfunction in another system (for example, the engine).
- › In addition, the entry "B13BCF2 multi-collision brake no function" in the event memory must also be deleted in the airbag control unit.

# Multi-collision brake

## Procedure at the dealer

- **In the A6, A7, A8 and R8, the following applies:**
  - If there is only a short-term fault or deactivation of the brake electronics, the ESC warning lamp is switched off again at the latest after the next ignition cycle.
  - However, the airbag warning lamp continues to be permanently activated and can only be deactivated by the partner by deleting the entry "B13BCF2 multicollision brake no function" in the airbag control unit.
  - The function of the multi-collision brake also remains unavailable until this entry in the airbag control unit is deleted.
  
- The reason for the deactivation of the multi-collision brake is solely a prior deactivation of the ABS/ESC, even if only the airbag warning lamp is lit up

## Multi-collision brake

### Procedure at the dealer

- If the complaint has only occurred once and then does not reoccur, all entries in the event memory of the ESC are automatically deleted after 40 ignition cycles.
  - The entry "B13BCF2 multi-collision brake no function" in the airbag control unit remains stored even after 40 ignition cycles.
  - If there is a delay of several days until the event memory can be read (for example, due to the availability of appointments at the partner), the entry in the airbag control unit "B13BCF1 multi-collision brake no function" may be the only remaining entry when the event memory is read. In this case, the airbag warning lamp also remains the only lit warning lamp.
  - The dealer therefore has no indication of the prior deactivation of the ESC – either from an entry in the event memory or through a warning lamp.
- 
- The reason for the deactivation of the multi-collision brake is solely a prior deactivation of the ABS/ESC, even if no entry in the event memory directly indicates this

## **Multi-collision brake**

### Procedure at the dealer

- › If the deactivation of the ESC can no longer be detected and there is no related entry in the event memory, the partner can only perform the following measures:
  - › In the airbag control unit, delete the entry in the event memory "B13CF2 multicollision brake no function"
  - › Continue to monitor the vehicle without attempting a repair
  - › If the complaint reoccurs, read the event memory as soon as possible after the event

# Multi-collision brake

## Procedure at the dealer

- › **In the A3, TT, A4, Q7 and all future models, the following applies:**
  - › If there is only a short-term fault or deactivation in the brake electronics and the ESC function is not available again until after the next ignition cycle, then in these models the airbag warning lamp is also no longer actuated.
  - › In addition to the ESC warning lamp, the airbag warning lamp is also no longer activated after the ignition cycle and the function of the multi-collision brake is also active again.

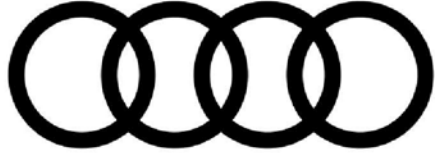

**Telephone**

# Telephone Agenda

**1** ASI; creating screenshots



# Telephone

## ASI; creating screenshots

### Screenshots for ASI:

- › Screenshots are sometimes required for analysis purposes in the case of complaints about the MMI. How these are created in the MMI has already been shown in earlier SoST training sessions.
- › Screenshots can also be created for ASI to document complaints or monitor the causes. In the case of such a screenshot, a record is kept of what information the telephone has sent to the vehicle. This is helpful in sporadic cases, such as a black screen or an "offset" display of the application.
- › As the display of the smartphone interface occurs on the smartphone, screenshots must be created with the telephone, and the images are also saved on the telephone. The way you create a screenshot is different, depending on whether you are using Apple CarPlay or Android Auto.
- › How to create a screenshot with the relevant system is explained on the following pages.

# Telephone

## ASI; creating screenshots

### Screenshots:

#### > Apple CarPlay

- > Where Apple CarPlay is activated, the normal screenshot function on the iPhone (On/Off button and home button) can be used to create a screenshot of the CarPlay content and of the telephone screen. These will both be saved on the smartphone under "Photos"

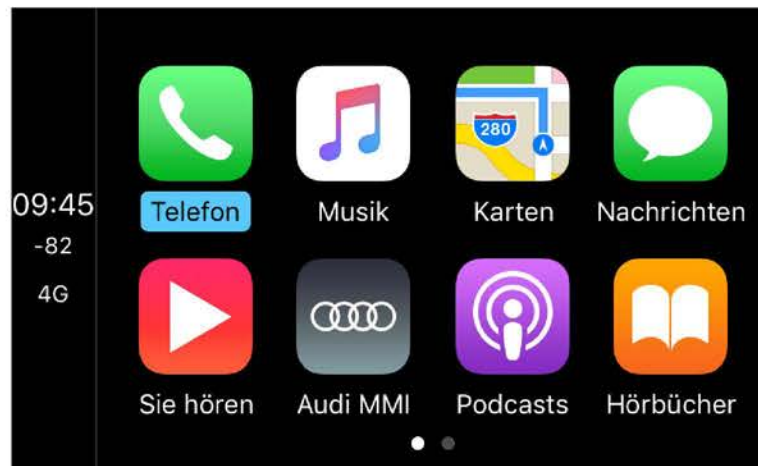

# Telephone

## ASI; creating screenshots

### Screenshots:

#### > Android Auto

- > To create screenshots with Android Auto, the Android Auto application on the smartphone must be in developer mode. Tap 7 times in the app on Android Auto (orange circle).
- > Then, under the menu options (green circle), call up the developer menu, set a check mark against "Save screenshot" (green circle).
- > After this, when Android Auto is activated, a screenshot can be created with "Share screenshot now" (blue circle), in the developer options on the smartphone. The screenshot will then be saved on the smartphone.

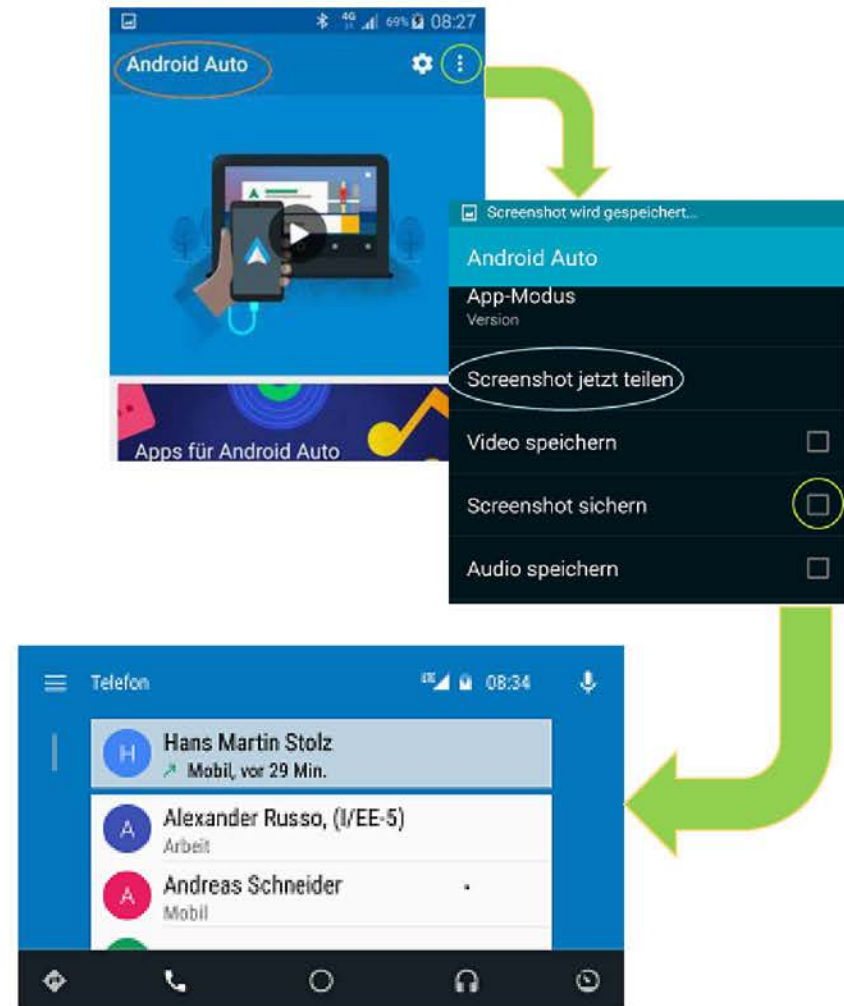

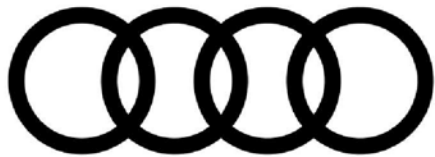

**Repair authorization for new model launches**

# Repair authorization for new model launches

## Key points

- › Always check if there is a repair authorization prior to repair during a new model launch
- › Typically, the repair authorization is active for 12 weeks of a new model launch

## Benefits:

- › Early detection of key topics/complaints
- › Possibility to access vehicles before repair for analysis purposes
- › Detect the cause of the complaint
- › Accelerate the fault resolution process
- › Accelerate the implementation of service solutions
- › Develop a constructive measure/software (SVM)
- › Information sharing between Audi dealers and AoA

# Repair authorization for new model launches

## Key points

Note following the repair authorization process:

- › Significantly delays the implementation of service solutions → customer dissatisfaction.
- › Can result in claim denial.

The facts:

- › Each month, over **30,000** A4/A5s are built at Audi in Ingolstadt/Neckarsulm.
- › Every day, over **35,000** platform vehicles are built within the Group (e.g. MQB = modular transverse matrix such as A3, Golf, etc.).
- › **The Audi partner is the first to analyze customer complaints, and therefore influences solutions and their implementations.**



# **Repair authorization for new model launches**

## **Component shipping control initiated at partner level**

### **Replaced parts during launch**

- › All requested parts must be shipped.
- › All parts must be properly packaged to avoid damage during shipping process.
- › All parts must not be altered, unless otherwise instructed by TAC.

### **Parts shipping**

- › Follow all shipping instructions and process.
- › There may be cases where parts are being requested for claims that have not yet been submitted in SAGA. This may be necessary to expedite the fault solving process.  
Address on a case-by-case basis.



# Repair authorization for new model launches

## Recent example: European launch of new Q7 (4M)

**Example: Issue with air spring on the front axle**



**2015**

September	October	November
<p><b>September 09</b> Initial report repair authorization prior to repair</p> <p><b>September 11</b> Start of fault elimination process</p>	<p><b>October 02</b> 1st use in series production, process optimization of air spring strut</p>	<p><b>November 02</b> 2nd use in series production, additional two-stage press in of shock absorber mounting and roller membrane</p>

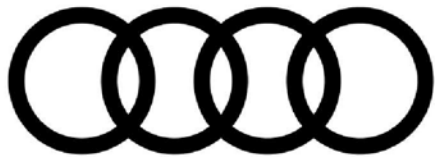

**Running gear: Steering systems – intermediate steering shaft and dynamic steering**

## Intermediate steering shaft

### Squeaking noises from the intermediate steering shaft

#### Vehicles:

- › B8 & C7 – various model years.
- › Always use VIN to check for TSB.

#### Cause:

- › Intermediate steering shaft is insufficiently lubricated in the area of the sealing boot.

#### Action:

- › Check for proper installation of the sealing boot.
- › Updated repair involves disconnecting the intermediate steering shaft from the steering column in order to pull out the intermediate steering shaft by approx. 4 in (10 cm), and spray with special lubricant in the area of the black plastic sleeve and the inner bearing race.
- › It is critical to follow all steps in the TSB to prevent repeat repairs.

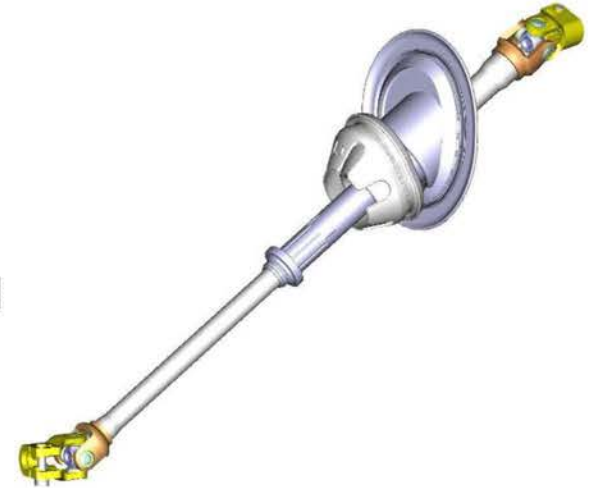

# Intermediate steering shaft

## Functions

### Vehicles:

- › Optional in A4/A5/A6/A7/A8/Q5.
- › PR no. 1N7/1N8.

### Function:

- › Steering ratio depends on vehicle speed and Audi drive select setting.

### Benefits:

- › Agile handling with low steering angle required ("go-kart feeling").
- › Easy vehicle guidance and precise steering sensation at high speed.

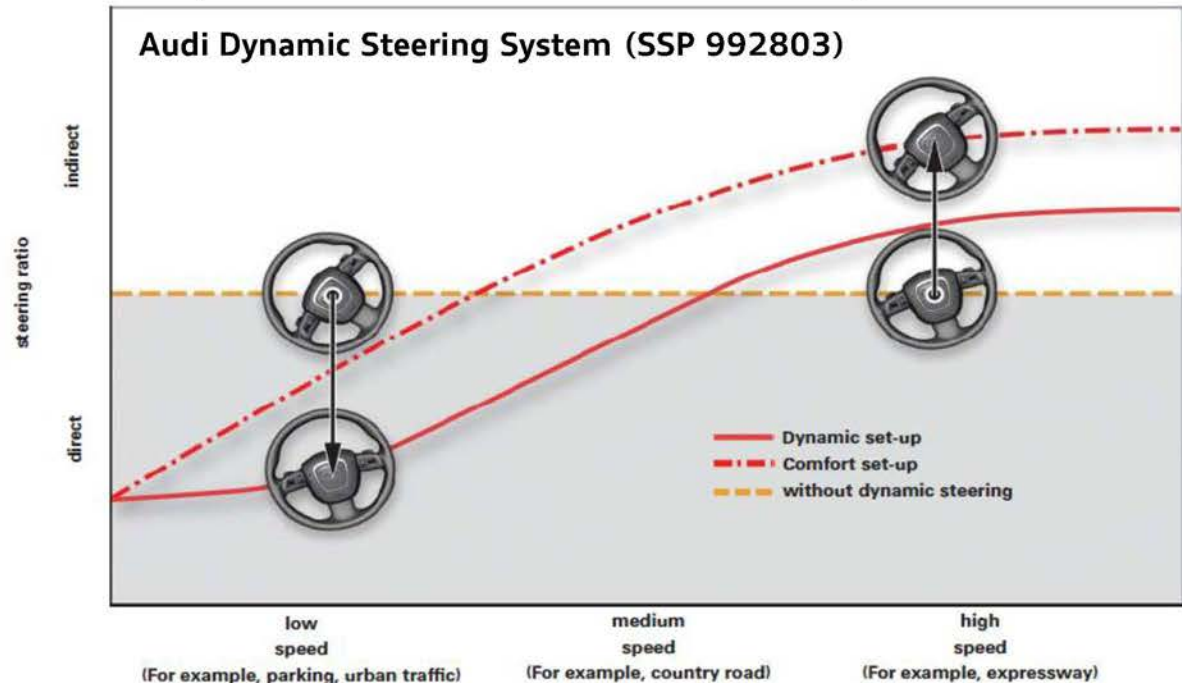

# Intermediate steering shaft

## Functions

### Benefits (cont.):

- › In less critical driving situations, braking can be reduced or even eliminated by relying more on corrective steering inputs to stabilize the vehicle.
- › Overall stability of the vehicle is improved through simultaneous corrective braking and steering inputs. This is especially true at speeds greater than 60 mph, due to the dynamic steering system being able to take advantage of its quick reaction times.



### Basic setting:

- › Check the calibration of the steering angle sensor.
  - › Deviation between measured value and actual steering wheel angle  $\leq 0.3^\circ$
  - › Steering angle sensor cannot be programmed → Service information: TSB 2043629
- › Align wheels straight ahead (wheel alignment).
- › Perform the dynamic steering basic setting.

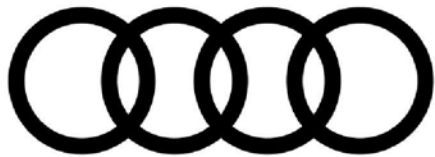

**RS 7, R8 wet fade brake compensation (WFC)**

# RS 7, R8 wet fade brake compensation (WFC)

## Function

- › In wet weather conditions, a thin film of water can form on the friction surface of the brake disc, which initially has to be rubbed away by means of the first braking action. This can lead to an impaired level of comfort due to the sensation that extra braking force is required. This situation is unavoidable for physical reasons.
- › In order to minimize the influence of the principles described above on the pedal sensation and to make the initial braking action more comfortable, in the Audi RS 7 (from model year 2015) and R8 (new model) the function "wet brake fade compensation" (WFC) has been introduced.
- › WFC is activated when the wipers are actuated either permanently or in interval mode, or if the rain sensor is active, when the wiper is actually in action. WFC remains active for a further three minutes following the last actuation of the wiper, after which time the function is deactivated. The WFC is also activated through actuation of the wiper washing mechanism, and remains active for three minutes.



# RS 7, R8 wet fade brake compensation (WFC)

## Function

- WFC compares the brake pressure applied by the driver via the brake pedal with the delay that then follows. If the detected delay is considerably less than would be expected based on the hydraulic brake pressure, WFC contributes to active braking via the ABS unit. The time from the first actuation of the pedal until active braking of the WFC is approx. 0.5 seconds. Via the ABS unit, the brakes are then applied to a deceleration value that is appropriate for the initiated hydraulic brake pressure and therefore the driver's requirements.
- The driver then senses that the path of the brake pedal becomes longer for a brief period, and a pulsing of the brake pedal occurs that is similar to ABS braking. The additional braking via the WFC can be noticeably sensed by the driver depending on the situation.
- » For drivers with no experience of the mechanism of action of the WFC, an intervention by the WFC can initially feel strange, although the braking itself is made more comfortable by the WFC.



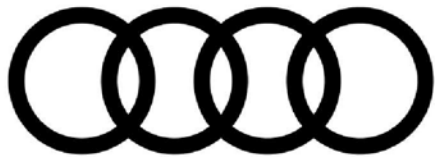

**Carbon fiber-reinforced plastic in the new R8 (4S)**

# Carbon fiber-reinforced plastic in the new R8 (4S)

## Agenda

**1** CFRP — Basic information about carbon-fibre-reinforced plastic

---

**2** CFRP — Carbon-fibre-reinforced plastic in the new Audi R8/4S

---

**3** Support strategy for CFRP structural repairs

---

**4** CFRP at service partners

# CFRP – Information about carbon fiber-reinforced plastic

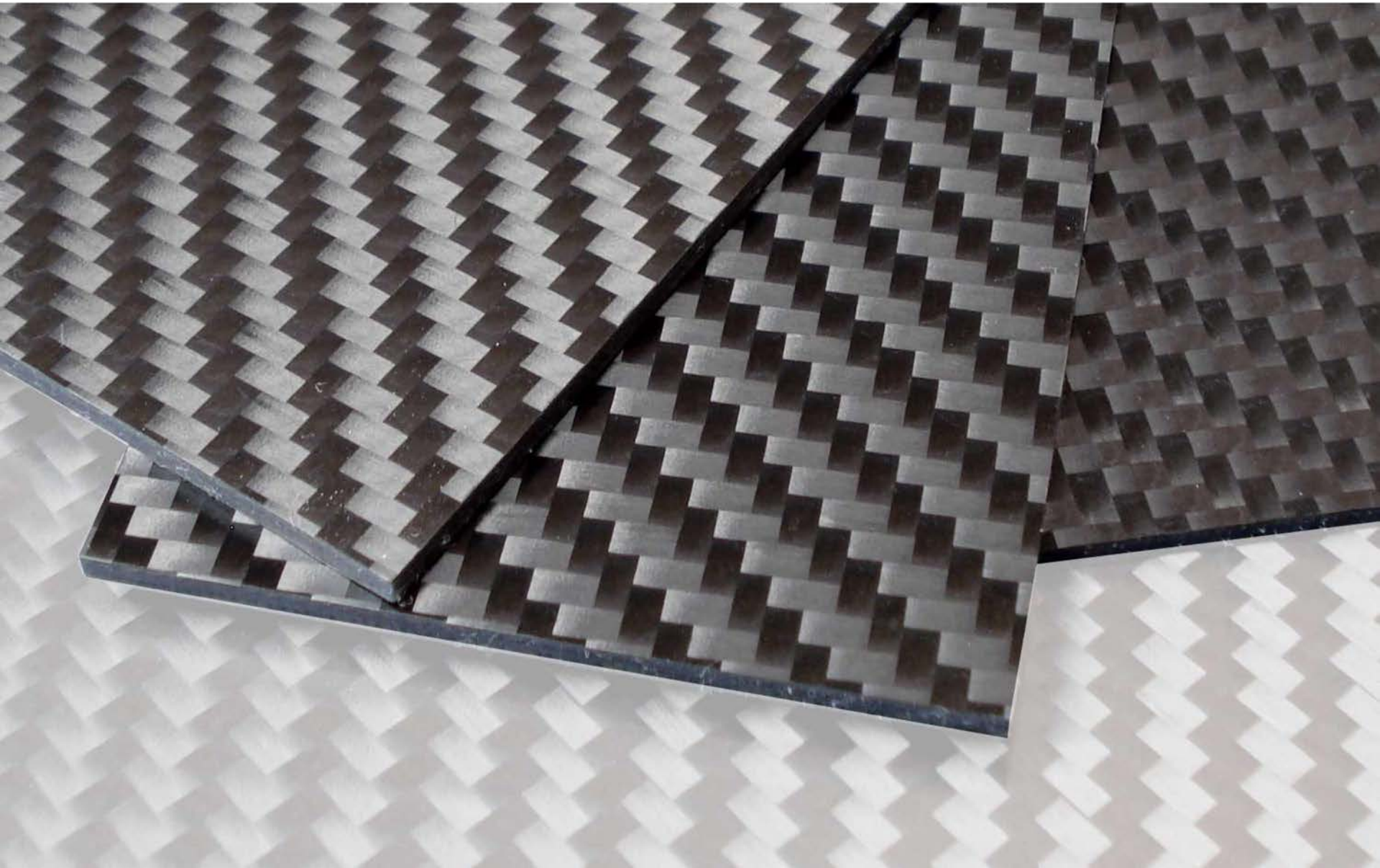

# CFRP – Information about carbon fiber-reinforced plastic Composites

- > Combination of two or more components
- > Has the advantages of the individual components
  - Properties that cannot be achieved by a single component
- > Depending on the geometry of the material combination

> Particle composite



> Multilayer composite



> Fiber composite



# CFRP – Information about carbon fiber-reinforced plastic

## Fiber composites

Fiber-reinforced plastics (FRP), or fiber-reinforced polymers, are a subgroup of composite materials.

Composite materials are materials that combine various different components.

This combination of components makes it possible to achieve properties that cannot be produced using a single component alone.

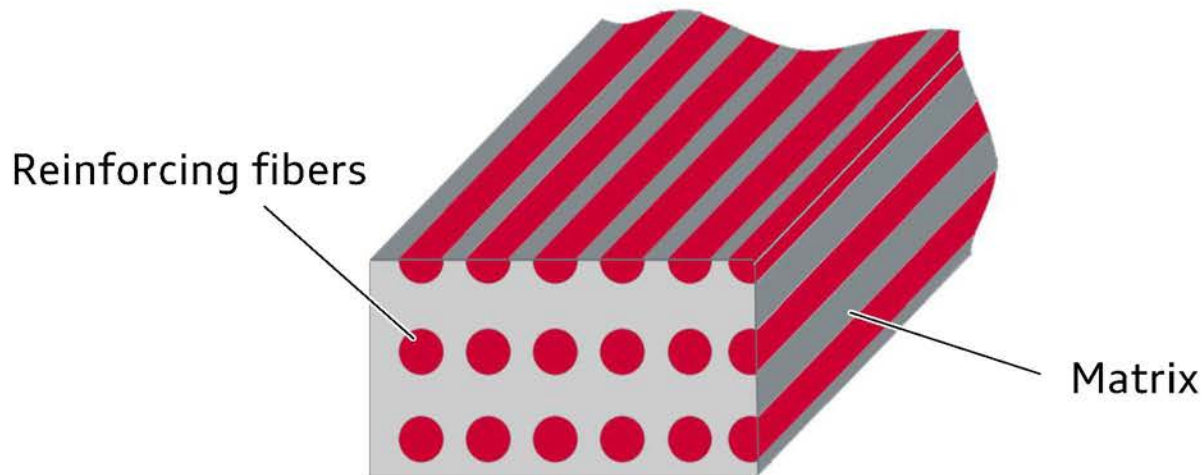

# CFRP – Information about carbon fiber-reinforced plastic

## Reinforcing fibers

### Natural fibers

- › Wool, silk, cotton, flax, hemp

### Organic fibers

- › Polyethylen, Polyester, aramid, carbon

### Inorganic fibers

- › Glass, basalt, quartz

### Metal fibres

- › Steel, aluminum, copper, nickel

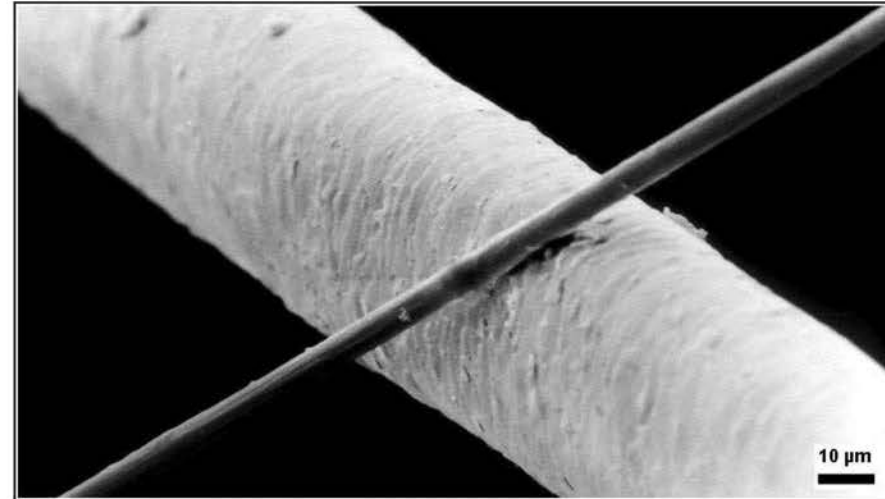

Comparison: Carbon fiber, human hair



# CFRP – Information about carbon fiber-reinforced plastic

## Reinforcing fibers

### Task of the fibres:

- > Load transfer
- > Absorption of elongation
- > Determination of mechanical properties
  - Rigidity
  - Strength
  - Thermal expansion

**Only tensile forces, no compressive forces**

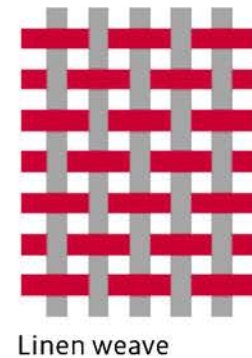
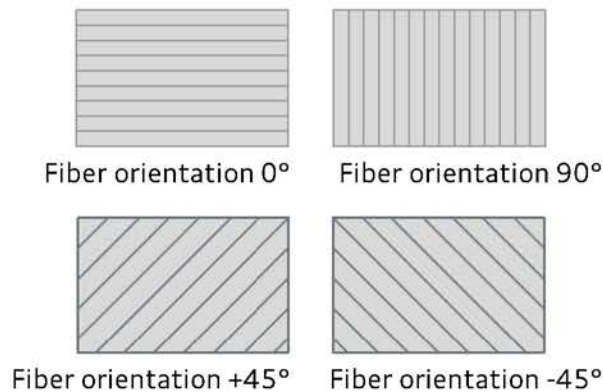
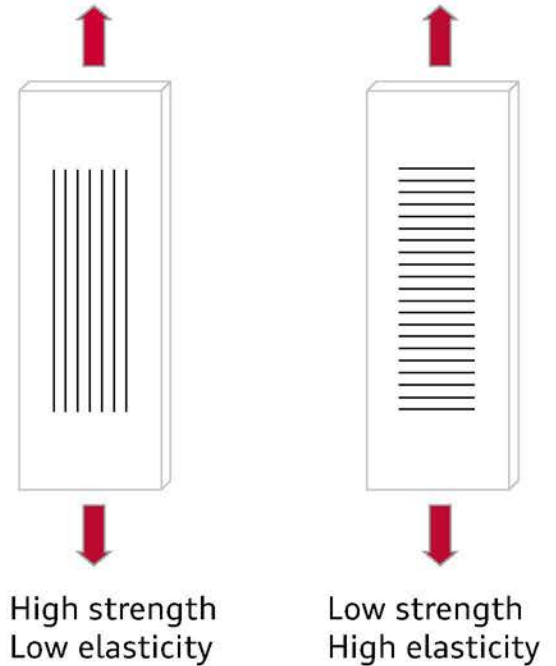



# CFRP – Information about carbon fiber-reinforced plastic Matrix

## Task of the matrix

- › Prevents kinking of the fibers (for added strength under compressive stress)
- › Interlocking of the individual fibers
- › Determines the mechanical properties (rigidity, strength, thermal expansion)
- › Protection of the fibers
- › Fixing of the fibers (shape and stability)

## Material of the matrix

- › Epoxy resin, polyester resin, phenolic resin

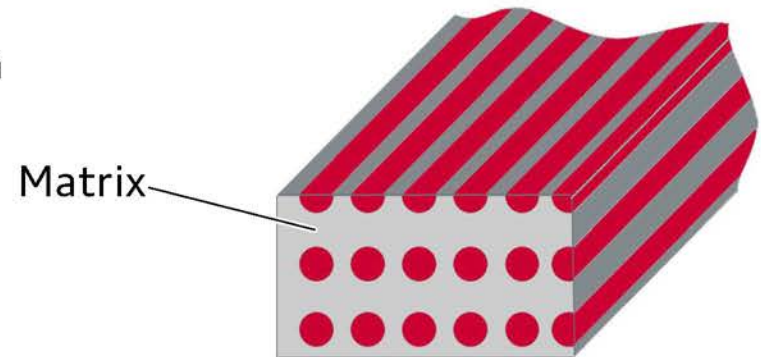

# CFRP – Information about carbon fiber-reinforced plastic

## Fiber composites

**Designer composite – with variable properties ranging from high strength to high rigidity**

Influenced by:

- › Fiber – resin combination
- › Fiber orientation and layer construction
- › Local patches and reinforcements
- › Manufacturing process



# CFRP – Information about carbon fiber-reinforced plastic

## Comparison of CFRP weight

Component weight ratios when performing the same function

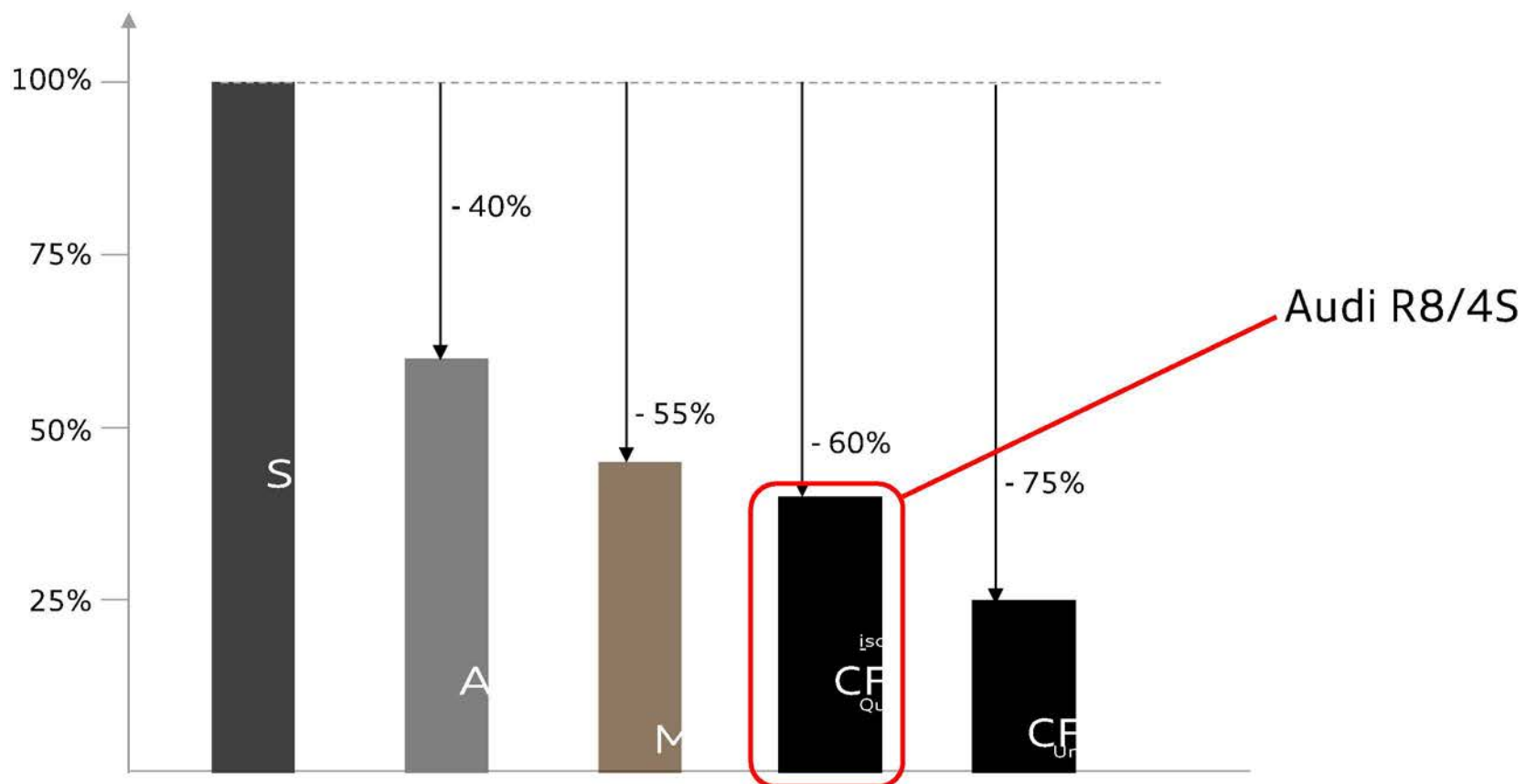

# CFRP – Information about carbon fiber-reinforced plastic

## Comparison of strength/rigidity

### Low weight

- › Due to low density of materials
- › Due to optimum use of materials

### High strength/rigidity

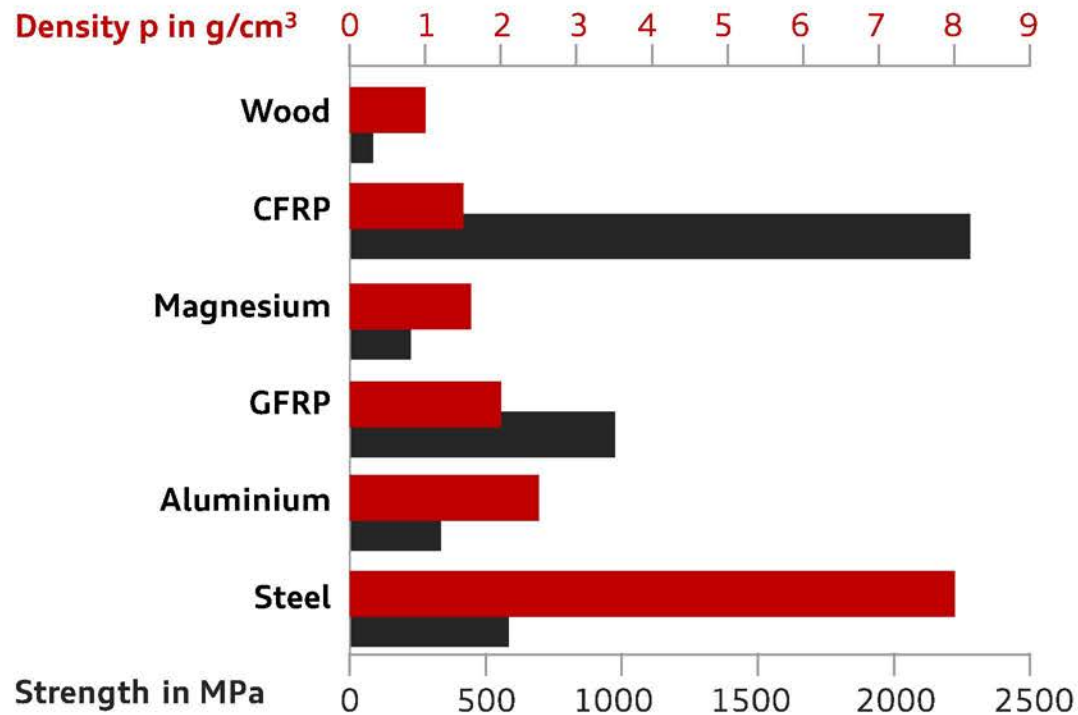

# CFRP – Information about carbon fiber-reinforced plastic

## Resin transfer molding (RTM) production process

10–60 seconds

5–10 minutes, 80–120°C

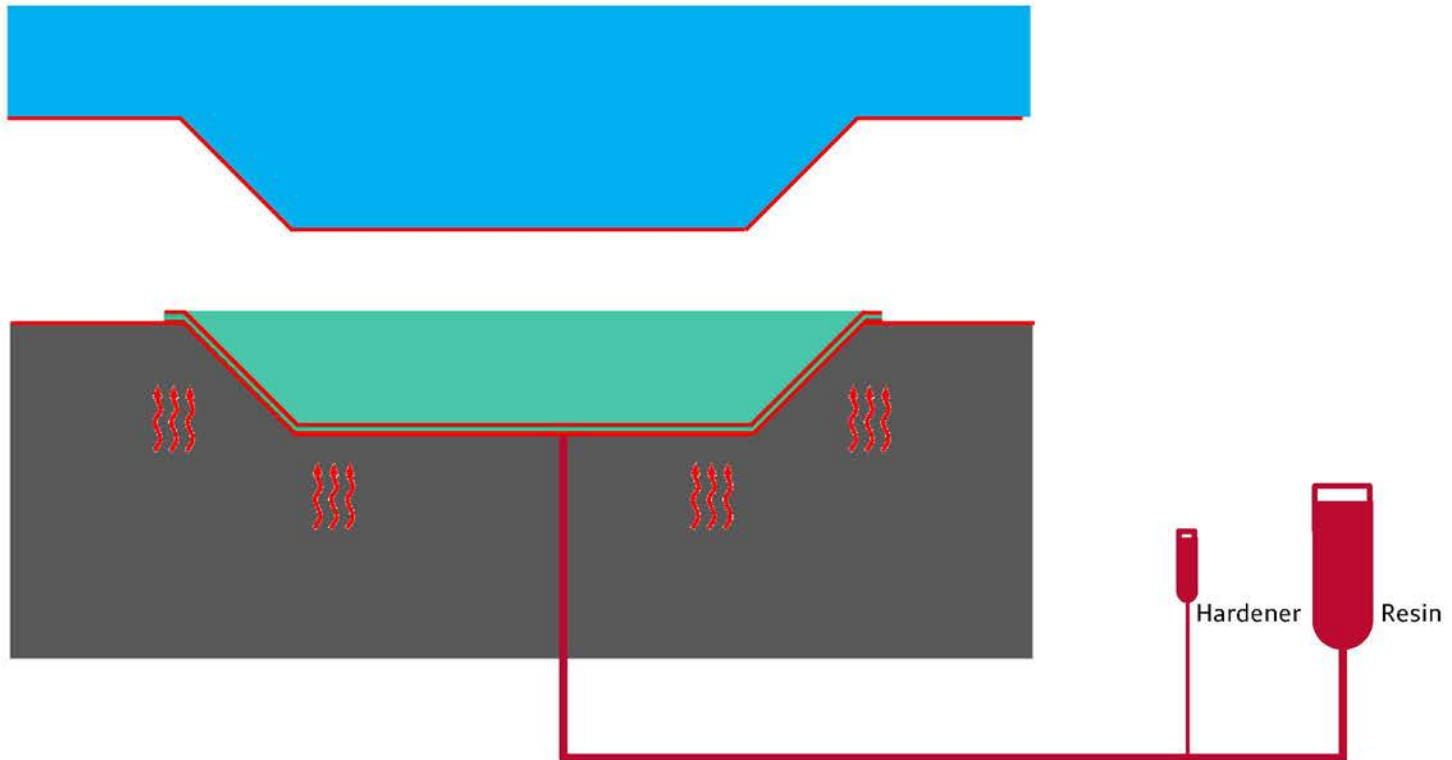

# CFRP in the new R8 (4S)





# CFRP in the new R8 (4S)

## CFRP at Audi

### Visible CFRP

- > Non-crimp fabric for the top layer
- > Clear coat as surface protection



### Class A CFRP

- > Colour-painted
- > Mostly used for exterior add-on parts



### CFRP structure

- > New in the R8 (type 4S)



## CFRP in the new R8 (4S)

### Why carbon fiber-reinforced polymers?

- › Low weight
- › High strength / rigidity
- › Low thermal expansion
- › High corrosion resistance
- › Broad scope for design
- › Good aging properties / fatigue strength
- › High energy absorption capacity (crash performance)

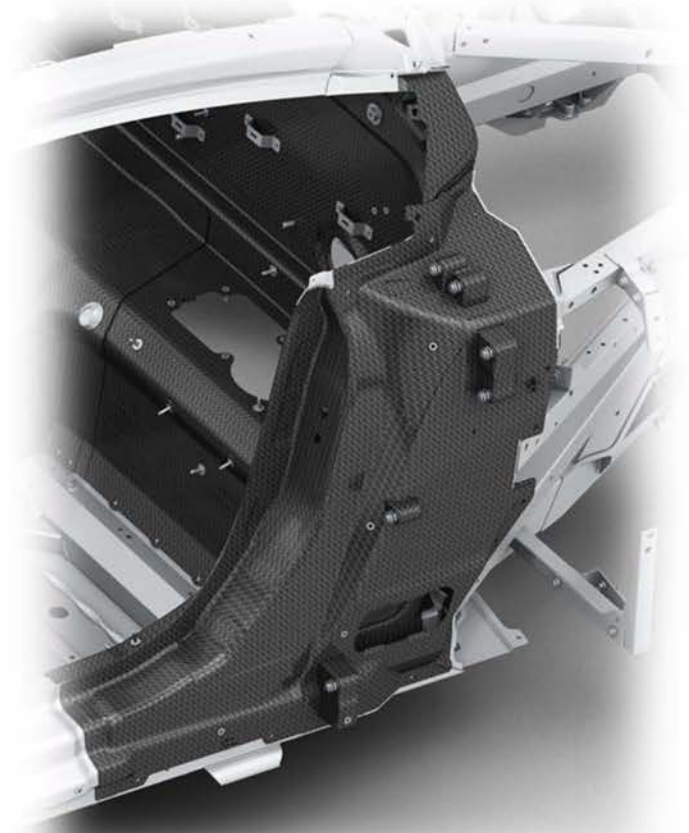

## CFRP in the new R8 (4S)

### Multi-material Audi space frame (ASF)

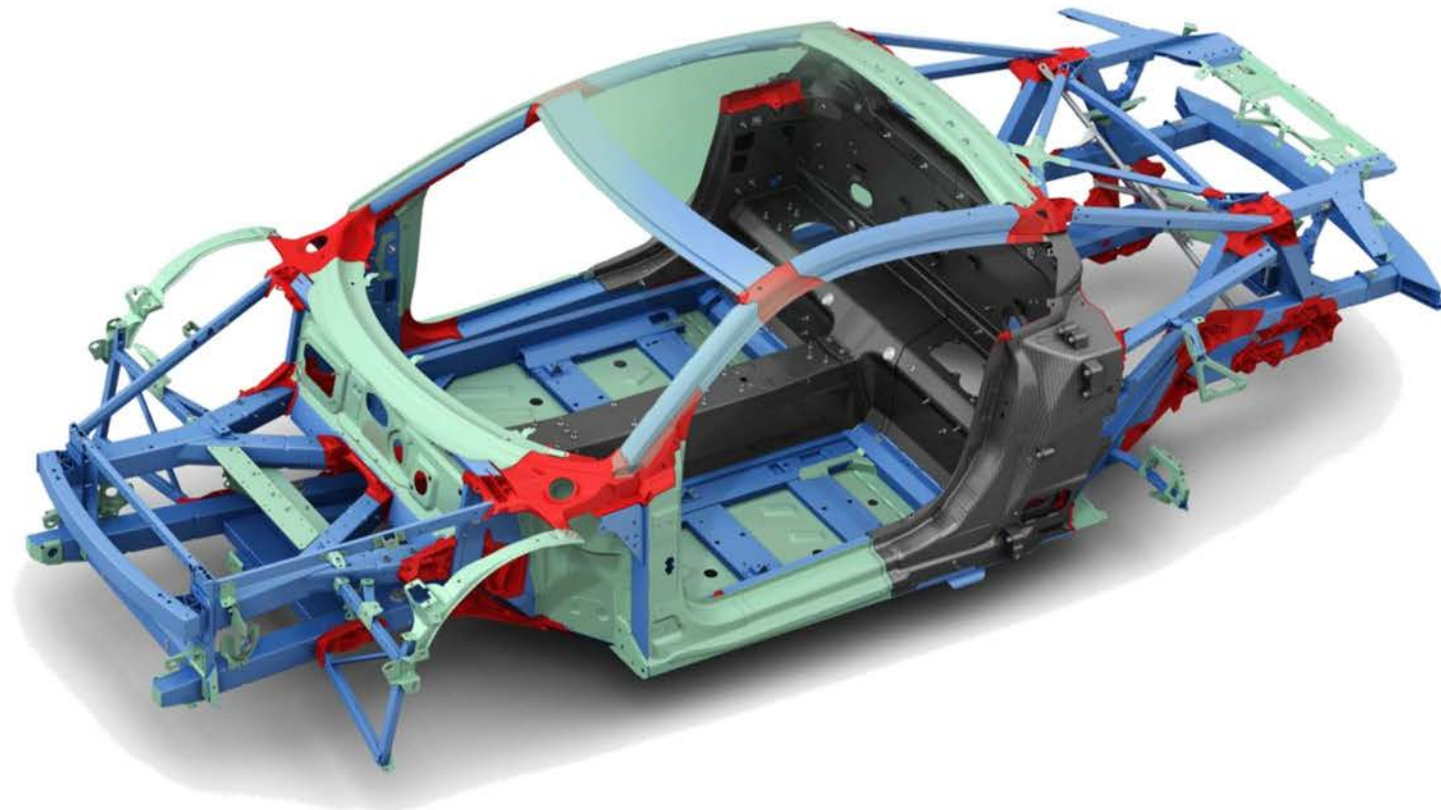

- ▶ MSS (Modular Sportscar System) platform
- ▶ 13 percent carbon fibre reinforced polymer (CFRP) in the body structure
- ▶ The body structure is 10 kilogrammes lighter than that of the previous model
- ▶ Static torsional rigidity is 40 percent higher than that of the previous model

# CFRP in the new R8 (4S)

## CFRP parts



# CFRP in the new R8 (4S)

## Joining techniques



- > 89 metres of MIG weld seams
- > 270 semi-tubular punch rivets
- > 207 pop rivets
- > 241 metric screws
- > 270 self-tapping screws



# Support strategy for CFRP structural repairs



# Support strategy for CFRP structural repairs

## Why have a support strategy?

### New requirements for diagnostic and repair process

- › New process for diagnostic and repair of accident damage
- › Special workshop equipment is required
- › Damage diagnostic by ultrasound measurement
- › Experience is required for the various works operations

### Ensuring highest quality repairs

- › Centralised development of knowledge and expertise
- › Achieving process reliability



- ›› AUDI is using **CFRP** in its vehicle structure for the first time, so we must work together to become familiar with this new technology and continue to adapt our support strategy accordingly.

# Support strategy for CFRP structural repairs

## CFRP support points Europe

- ▶ Projected CFRP diagnoses during start-up phase
  - ▶ Germany and Europe (exluding UK): flying technicians of AUDI AG
  - ▶ UK: diagnostic technicians of importer





# Support strategy for CFRP structural repairs

## Process

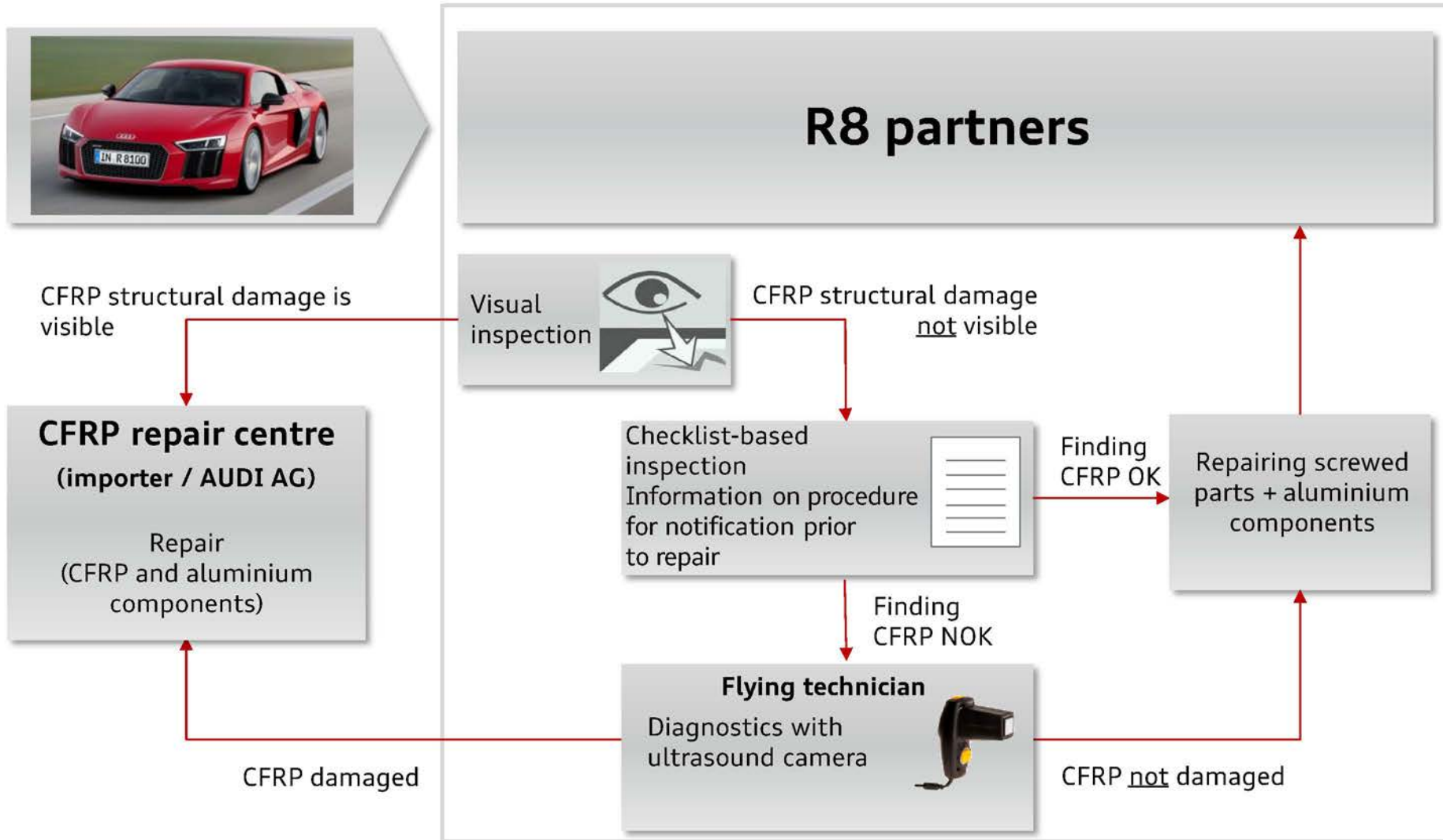

# Support strategy for CFRP structural repairs

## Process

- ▶ Vehicle check-in
  - ▶ Entry of vehicle identification number in Elsa – Information on procedure for notification prior to repair
  - ▶ Preparation of the DISS notification
  
- ▶ Diagnostics
  - ▶ Inspection based on assessment form (available through Workshop Manual / Diss)
  - ▶ If necessary, call in a flying technician for ultrasound diagnostics
  
- ▶ Transportation for repair
  - ▶ Commissioning through R8 partner (enclosed transportation)
  - ▶ Expert assessment of scope of repair prior to transportation
  
- ▶ Repair
  - ▶ Declaration of cost acceptance by R8 partner
  - ▶ Repair of aluminium and CFRP components (vehicle ready for hand-over)

# Support strategy for CFRP structural repairs

## Flying Technician – CFK diagnose

### ► Ultrasonic testing – DolphiCam

- For non-destructive testing in the workshop, the ultrasonic phased array system from Dolphi Tech is used.

### ► Ultrasonic testing method

Short ultrasonic pulses are emitted during the test (pulses are between  $1 \mu\text{s}$  and  $10 \mu\text{s}$ ). The sound travels through material, is reflected by the rear panel and is received by the testing head again in the form of an echo. The actual data is compared with target data to uncover any deviations.

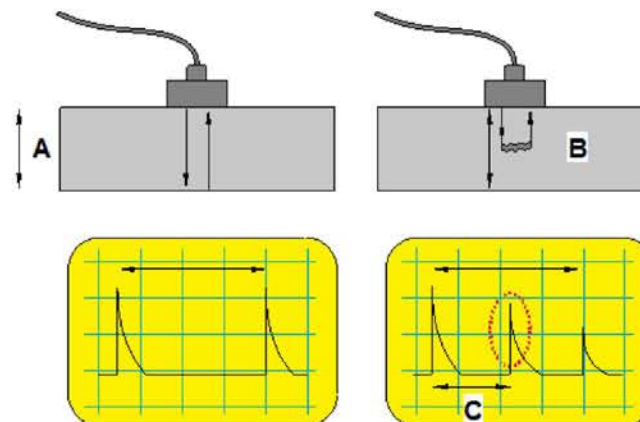

A = Material thickness

B = Damage/delamination

C = Fault depth

# Support strategy for CFRP products

## Flying Technician – CFRP diagnose

- ▶ Ultrasonic testing – DolphiCam





# Support strategy for CFRP products

## Flying Technician – CFRP diagnose

► DolphiCam data evaluation

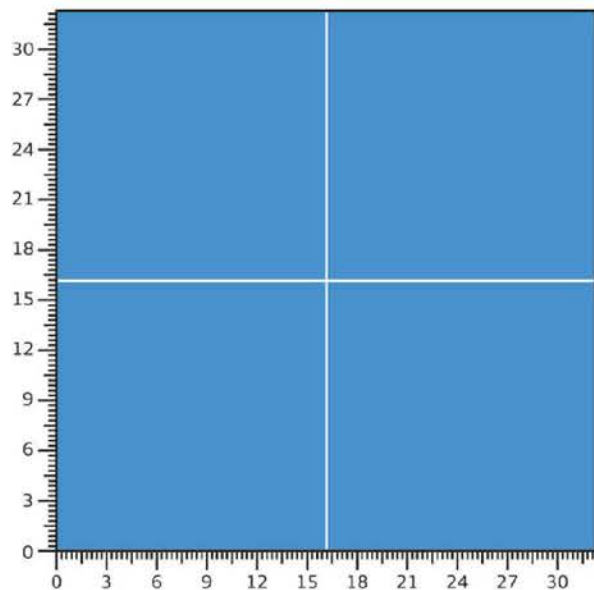
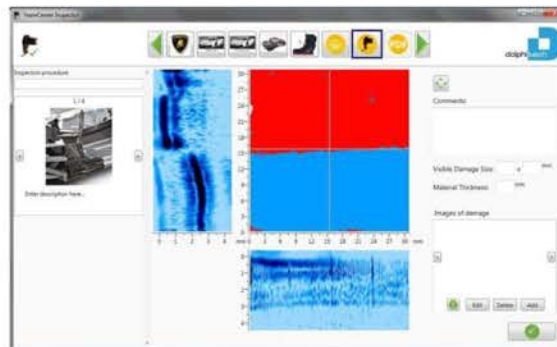

Fault-free area

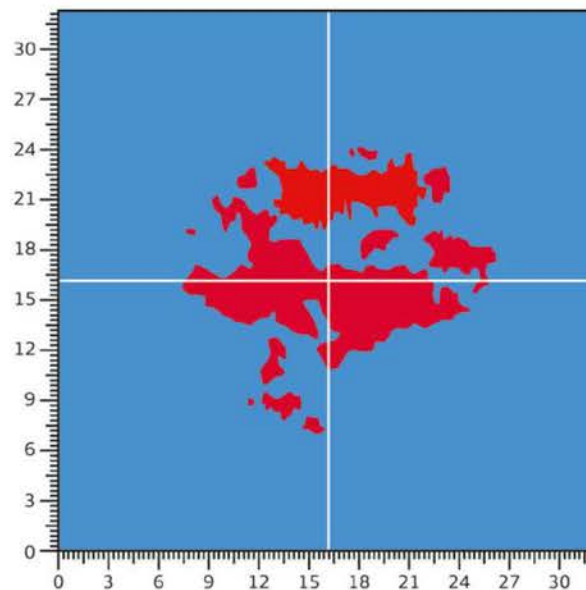

Area with faulty CFRP

# Support strategy for CFRP products

## Flying Technician – CFRP diagnose





# CFRP at Audi partners



# CFRP at Audi partners

## Cost evaluation of workplace/tools

Tools	
€38,000* +	
€65	
incl. app	Duration: approx. 8 - 10 days
	imum repair centre
	€57,000
	(tools and qualification)
	Steel
a CFRP extractor is available and alignment bracket sets can be hired	

**These costs are not currently relevant due to the support strategy**

## **CFRP at Audi partners**

### Hazards and risks when handling CFRP

#### **CFRP fibres are not normally respirable**

- › Fibre changes at temperatures above 650°C  
→ Dust particles of critical size
- › Important to protect the skin and mucous membranes

#### **Risk of splintering possible if broken, depending on the component**

- › Coated gloves must be worn to protect against cuts

#### **Risk of short circuit**

- › CFRP is electrically conductive

#### **In some cases, damage can be difficult to detect**

- › Potential delamination may not be visible from the outside
- › As CFRP can return to its original shape following an accident, damage to the CFRP structure may be overlooked



# CFRP at Audi partners

## Important

- › No drilling, sawing, grinding, cutting or other machining of CFRP components is permitted
- › Do not use CFRP to establish an earth connection
- › Only use manufacturer-approved materials (primers, adhesives, rivets, etc.)
- › Only use manufacturer-approved procedures
- › Only use manufacturer-approved tools
- › When carrying out repairs on the vehicle, or removing and refitting components such as mechanical units, it is essential to avoid hard contact with CFRP → risk of impact

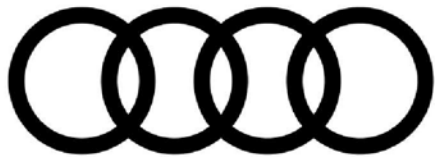

**Exterior: Door control unit – door contact switch monitoring**

# Door control unit – Door contact switch monitoring

## Agenda

**1** Current complaints from the market

---

**2** Affected models

---

**3** Affected models in detail



# Door control unit – Door contact switch monitoring

## Current complaints from the market

### Background for

#### "Door contact switch monitoring"

- › Software logarithm based on a defined driving cycle for monitoring the door lock (lock status)

#### Driving cycle:

- › Ignition on > Drive faster than 10 km/h (counter +1)
- › Park vehicle > Open the driver door (counter -1)

#### Malfunction of the door contact switch:

- › The end of the driving cycle is not detected
- › A counter in the door control unit is incremented by 1 for each new driving cycle started
- › When the counter reaches 5, the warning message is issued

### Background to the complaint

A software error in the door control unit causes a misinterpretation of the driving cycle and therefore an unjustified error response in the instrument cluster



# Door control unit – Door contact switch monitoring

## Affected models

**Audi A4 (8W)**



**Audi Q7 (4M)**



**Audi A3 (8V)**



# Door control unit – Door contact switch monitoring

## Affected models in detail



**Audi A3 (8V)**

### General

- > First model with door contact switch monitoring

### Cause of the error

- > Customer driving profile

### Action

- > Customer awareness
- => Software solution in development



**Audi A4 (8W)**

### General

- > 100% KESSY-Go installation

### Cause of the error

- > Software error in the door control unit

### Action

- > Service measure 96D5



**Audi Q7 (4M)**

### General

- > 100% KESSY-Go installation

### Cause of the error

- > Software error in the door control unit

(significantly later error response vs. B9)

### Action

- > SVM code 42A004

# Door control unit – Door contact switch monitoring

## Summary

### Customer complaint

Fault message relating to the parking brake or driver door plus a warning tone every time the car drives from a standstill

### Background for "Door contact switch monitoring"

A software logarithm was written to monitor malfunctions of the contact switch in the driver's door.



One driving cycle in the vehicle is defined as follows:

- > Ignition on
- > Drive faster than 10 km/h
- > Park vehicle
- > Open driver door

If the door lock is defective, the end of the driving cycle is not detected; a counter in the door control unit is incremented by 1 for each new driving cycle started (when the vehicle is driven faster than 10 km/h). When the counter reaches 5, the warning message is issued.

### Background to the complaint

A software error in the door control unit causes a misinterpretation of the driving cycle and therefore leads to the unauthorised increase in the counter value.

### Action

- > Change to the standard software in the door control unit in week 7/2016

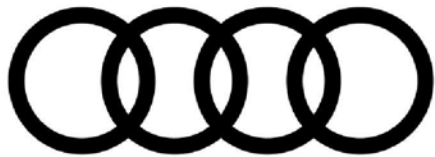

**Running gear: Steering wheel heating – function and diagnosis**



# Steering wheel heating – function and diagnosis

## Agenda

**1** Initial use and facts on steering wheel heating at Audi

---

**2** Steering wheel heating: structure and function

---

**3** Diagnosis

---

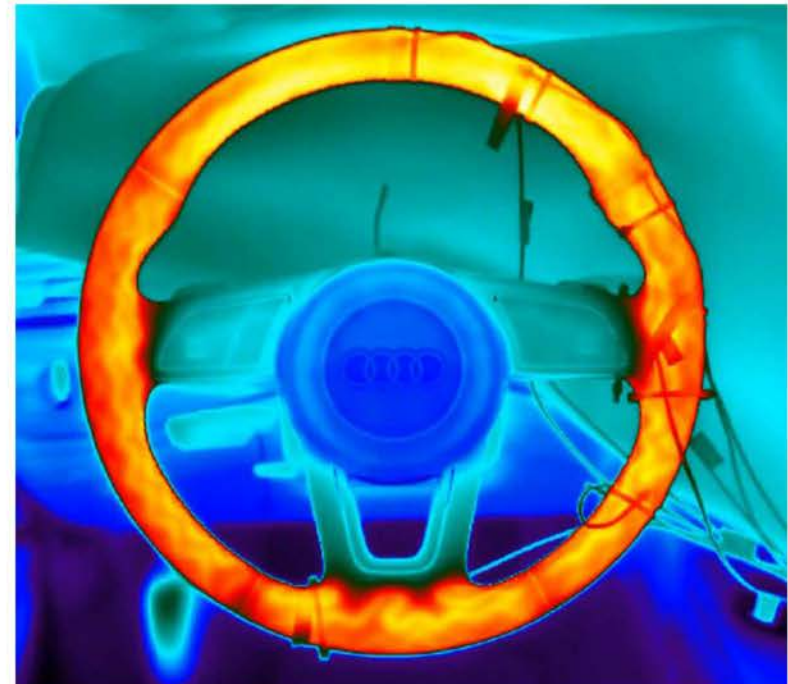



# **Steering wheel heating – function and diagnosis**

## Initial use and facts on steering wheel heating at Audi

- › **First used on the Audi A8 D2**
  - › 24°C heating temperature combined with seat heating (no switch provided)
- › **Temperature increase in the model year 2007**
  - › From 24°C to 28°C as well as the introduction of a dedicated switch on the steering wheel (on the reverse side of the spokes)
- › **Changes on the Audi A8 D4**
  - › Activation button moved to the front side of the spokes
- › **Temperature increase in the model year 2015**
  - › From 28°C to 34°C
- › **Flattened steering wheels are not offered with heating**
- › **Heat-up duration dependent on the ambient temperature**
- › **Steering wheel heating can be personalised for four vehicle keys only**
  - › No function available for the fifth replacement key onwards

# Steering wheel heating – function and diagnosis

## Steering wheel heating: structure and function

### › Steering wheel structure in five steps

- › Base frame › Foam › Heating pad › Foam › Leather cover
- › Advantages:
  - › Improved temperature distribution
  - › Wires remain hidden after environmental influences

### › Steering wheel heating functionality

- › Power to the heating pad of the steering wheel via the SCSM\* and coil connector
- › Temperature control and regulation takes place in the SCSM
- › The temperature sensor is located on the heating pad
- › Power to the heating pad between 6–8.5A
- › Steering wheel heating has a single stage



\* SCSM = steering column switch module (16 – steering column electronics)

# Steering wheel heating – function and diagnosis

## Diagnosis

Diagnostic address 16

Measurement value: steering wheel heating

Offboard Diagnostic Information System Engineering - 6.7.2

Fzg-Projekt: AU49X (Engineering) Fzg-Bezeichnung:  Fzg-Verbindung: VAS  
 Fzg-ID: --- Fzg-Status: KL3

Measurement values – display measurement values

Messwert-Name	RDID	Wert	<input checked="" type="checkbox"/> Lesen	Adr.
<b>Steering wheel heating</b>				
Temperature		11 °C		
Current, actual value		6,40 A		
PWM duty factor		100 %		
Voltage at the sensor		2,00 V		
Voltage at the switch		High-Pegel		

# Steering wheel heating – function and diagnosis

## Video



# Steering wheel heating – function and diagnosis

## Conclusion

- » Steering wheel heating can only be operated with four different vehicle keys
  - » If a fifth vehicle key is used, the steering wheel heating will not work
- » Heat-up duration dependent on the ambient temperature
- » From model year 2015 onwards, the heating temperature is 34°C (previously 28°C)
- » Flattened steering wheels are not offered with heating
- » Power consumption is between 6 and 8.5A
- » Steering wheel heating has a single stage
- » Function can be activated and diagnosed via the final control diagnosis



**Thank you!**