

# TCO Certified Displays 7.0



**11 November 2015**

## Contents - TCO Certified Displays

<b>CERTIFICATION SUPPORT .....</b>	<b>5</b>
<b>INTRODUCTION.....</b>	<b>6</b>
<b>A            CRITERIA .....</b>	<b>7</b>
<b>A.1          GENERAL INFORMATION .....</b>	<b>7</b>
A.1.1    INFORMATION TO END-USERS .....	8
<b>A.2          VISUAL ERGONOMICS .....</b>	<b>10</b>
A.2.1    IMAGE DETAIL CHARACTERISTICS.....	11
A.2.1.1 <i>Native display resolution requirement</i> .....	11
A.2.2    LUMINANCE CHARACTERISTICS .....	12
A.2.2.1 <i>Luminance level</i> .....	12
A.2.2.2 <i>Luminance uniformity</i> .....	13
A.2.2.3 <i>Black level</i> .....	14
A.2.2.4 <i>Luminance uniformity - angular-dependence</i> .....	15
A.2.2.5 <i>Greyscale gamma curve</i> .....	16
A.2.3    LUMINANCE CONTRAST CHARACTERISTICS .....	17
A.2.3.1 <i>Luminance contrast – characters</i> .....	17
A.2.3.2 <i>Luminance contrast – angular dependence</i> .....	18
A.2.4    SCREEN COLOUR CHARACTERISTICS .....	19
A.2.4.1 <i>Correlated colour temperature, CCT, variation</i> .....	19
A.2.4.2 <i>Colour uniformity</i> .....	20
A.2.4.3 <i>RGB settings</i> .....	21
A.2.4.4 <i>Colour uniformity – angular dependence</i> .....	22
A.2.4.5 <i>Colour greyscale linearity</i> .....	23
<b>A.3          WORKLOAD ERGONOMICS.....</b>	<b>24</b>
A.3.1    VERTICAL TILT .....	25
A.3.2    VERTICAL HEIGHT .....	26
<b>A.4          EMISSIONS .....</b>	<b>27</b>
A.4.1    ALTERNATING ELECTRIC FIELDS .....	28
A.4.2    ALTERNATING MAGNETIC FIELDS .....	29
A.4.3    ACOUSTIC NOISE .....	30
<b>A.5          ELECTRICAL SAFETY .....</b>	<b>31</b>
A.5.1    ELECTRICAL SAFETY.....	31
<b>A.6          ENVIRONMENT.....</b>	<b>32</b>
A.6.1    PRODUCT DESCRIPTION.....	33
A.6.2    MANUFACTURING.....	36
A.6.2.1 <i>Environmental management system certification</i> .....	36
A.6.3    CLIMATE.....	38
A.6.3.1 <i>Energy consumption</i> .....	38
A.6.3.2 <i>Energy consumption – external power supply</i> .....	39
A.6.4    HAZARDOUS SUBSTANCES .....	40
A.6.4.1 <i>Cadmium (Cd), mercury (Hg), lead (Pb) and hexavalent chromium (CrVI)</i> .....	40
A.6.4.2 <i>Halogenated substances</i> .....	42
A.6.4.3 <i>Non-halogenated substances</i> .....	44
A.6.4.4 <i>Halogenated plastics</i> .....	46
A.6.4.5 <i>Phthalates</i> .....	48
A.6.4.6 <i>Hazardous substances in product packaging</i> .....	49
A.6.5    MATERIAL RESOURCE EFFICIENCY.....	50
A.6.5.1 <i>Lifetime extension</i> .....	50
A.6.6 <i>End of life</i> .....	52

A.6.6.1	Material coding of plastics .....	52
A.6.6.2	Take back system .....	54
A.6.6.3	Preparation for recycling of product packaging material .....	56
<b>A.7</b>	<b>SOCIALLY RESPONSIBLE MANUFACTURING .....</b>	<b>59</b>
A.7.1	SUPPLY CHAIN RESPONSIBILITY .....	60
A.7.2	SENIOR MANAGEMENT REPRESENTATIVE .....	63
A.7.3	CONFLICT MINERALS .....	65
<b>R</b>	<b>REFERENCES.....</b>	<b>67</b>
<b>B</b>	<b>TEST METHODS AND CLARIFICATIONS .....</b>	<b>71</b>
<b>B.0</b>	<b>GENERAL TEST CONDITIONS .....</b>	<b>71</b>
B.0.1	DEFINITION OF A TEST OBJECT .....	71
B.0.2	REQUIRED TEST OBJECT INFORMATION .....	71
B.0.3	GRAPHIC CARD (VIDEO ADAPTER).....	72
B.0.4	CONDITIONS FOR THE EQUIPMENT UNDER TEST .....	72
B.0.5	FPD ALIGNMENT FOR TESTING .....	73
B.0.6	INSTRUMENTS USED FOR TESTING.....	73
B.0.7	SETTINGS OF THE FPD .....	73
B.0.8	TEST IMAGE/TEST CHARACTER .....	73
B.0.9	TEST IMAGE AND TEST LUMINANCE SETTING.....	74
B.0.10	TEST REPORT .....	75
<b>B.1</b>	<b>GENERAL INFORMATION .....</b>	<b>76</b>
B.1.1	INFORMATION TO END USERS .....	76
<b>B.2</b>	<b>VISUAL ERGONOMICS .....</b>	<b>77</b>
B.2.0	GENERAL TEST CONDITIONS FOR VISUAL ERGONOMICS .....	77
B.2.0.1	Basic test requirements .....	77
B.2.0.2	Photometric test facility general requirements .....	77
B.2.0.3	Power supply and test room climate requirements for testing .....	77
B.2.0.4	Photometric and spectrometric measurements .....	78
B.2.0.5	Measurement distance .....	79
B.2.0.6	Stray light.....	79
B.2.0.7	Overall uncertainty .....	79
B.2.1	IMAGE DETAIL CHARACTERISTICS.....	80
B.2.1.1	Native display resolution requirement .....	80
B.2.2	LUMINANCE CHARACTERISTICS .....	81
B.2.2.1	Luminance level .....	81
B.2.2.2	Luminance uniformity .....	83
B.2.2.3	Black level.....	85
B.2.2.4	Luminance uniformity – angular dependence.....	86
B.2.2.5	Greyscale gamma curve.....	90
B.2.3	LUMINANCE CONTRAST CHARACTERISTICS .....	91
B.2.3.1	Luminance contrast – characters.....	91
B.2.3.2	Luminance contrast – angular dependence .....	96
B.2.4	SCREEN COLOUR CHARACTERISTICS .....	97
B.2.4.1	Correlated colour temperature (CCT) variation .....	97
B.2.4.2	Colour uniformity .....	99
B.2.4.3	RGB settings .....	101
B.2.4.4	Colour uniformity – angular dependence .....	102
B.2.4.5	Colour greyscale linearity .....	104
<b>B.3</b>	<b>WORKLOAD ERGONOMICS.....</b>	<b>105</b>
B.3.1	VERTICAL TILT .....	105
B.3.2	VERTICAL HEIGHT .....	105
<b>B.4</b>	<b>EMISSIONS .....</b>	<b>106</b>

B.4.0	GENERAL TEST CONDITIONS FOR EMISSIONS .....	106
B.4.0.1	<i>Basic test requirements</i> .....	106
B.4.0.2	<i>Conditions and set up for the test object</i> .....	106
B.4.0.3	<i>Emission measurement instruments</i> .....	110
B.4.1	ALTERNATING ELECTRIC FIELDS .....	113
B.4.2	ALTERNATING MAGNETIC FIELDS .....	116
<b>B.6</b>	<b>ENVIRONMENT</b> .....	<b>118</b>
B.6.0	GENERAL CLARIFICATION .....	118
B.6.0.1	<i>Signatures</i> .....	118
B.6.1	PRODUCT DESCRIPTION .....	118
B.6.2	MANUFACTURING .....	119
B.6.2.1	<i>Environmental management system certification</i> .....	119
B.6.3	CLIMATE .....	120
B.6.3.1	<i>Energy consumption – FPD</i> .....	120
B.6.3.2	<i>Energy consumption – external power supply</i> .....	120
B.6.4	HAZARDOUS SUBSTANCES .....	121
B.6.4.1	<i>Cadmium (Cd), mercury (Hg), lead (Pb) and hexavalent chromium (CrVI)</i> .....	121
B.6.4.2	<i>Halogenated substances</i> .....	121
B.6.4.3	<i>Non-halogenated substances</i> .....	122
B.6.4.5	<i>Phthalates</i> .....	125
B.6.4.6	<i>Hazardous substances in product packaging</i> .....	125
B.6.5	MATERIAL RESOURCE EFFICIENCY .....	125
B.6.5.1	<i>Lifetime extension</i> .....	125
B.6.6	END OF LIFE .....	125
B.6.6.1	<i>Material coding of plastics</i> .....	125
B.6.6.2	<i>Take back system</i> .....	126
<b>B.7</b>	<b>SOCIALLY RESPONSIBLE MANUFACTURING</b> .....	<b>127</b>
B.7.1	SOCIALLY RESPONSIBLE MANUFACTURING .....	127
B.7.1.1	<i>General Clarifications</i> .....	127
B.7.1.2	<i>Background information</i> .....	127
B.7.1.3	<i>The verification process</i> .....	128
B.7.2	SENIOR MANAGEMENT REPRESENTATIVE .....	131
B.7.2.1	<i>General Clarifications</i> .....	131
B.7.2.2	<i>SMR review</i> .....	131
B.7.3	CONFLICT MINERALS .....	133
B.7.3.1	<i>General Clarifications</i> .....	133
B.7.3.2	<i>Background information about the initiatives</i> .....	133
B.7.3.3	<i>The verification process</i> .....	135

# Certification Support

If you would like to certify your products and need support in understanding TCO Certified, this criteria document and the certification process, TCO Development's test and verification partners around the world are available to help clarify this document and assist you with certification in your native language.

For a list of accredited test and verification partners, contact;  
[certification@tcodevelopment.com](mailto:certification@tcodevelopment.com) or log onto [www.tcodevelopment.com](http://www.tcodevelopment.com)

# Introduction

TCO Certified is an international third party sustainability certification for IT products. By choosing TCO Certified computers, displays and other devices, businesses and organizations around the world are able to help meet environmental and social challenges associated with electronics.

Since the end of the 1980s, TCO Development has advanced the sustainable development of IT products. Today our international certification system – TCO Certified – makes it easier to choose sustainably designed and manufactured IT products such as displays, computers, smartphones and tablets. TCO Certified is a third party certification, Type 1 Eco Label according to ISO14024.

## Sustainability in all life cycle phases

Electronics are associated with many different sustainability risks throughout the life cycle, including manufacturing, use and end of life phases. Criteria in TCO Certified aim to address many of these challenges throughout the life cycle, making it the most comprehensive third party certification for IT products. For each criteria area in this document, the relevant life cycle phase is indicated by the following icons:



**Criteria - Manufacturing phase**  
Socially responsible manufacturing, environmental management system.



**Criteria - use phase**  
Climate, ergonomics, health and safety, extended product life and emissions.



**Criteria - end of life phase**  
Reduction of hazardous content and chemicals, design for recycling

With every major update we aim to enhance the criteria in line with technology innovation and sustainability challenges. Updates are a result of dialog with key stakeholders, such as purchasers, users, industry, and subject matter experts. This criteria document, TCO Certified Displays 7, is the seventh version of TCO Development's certification of computer displays. Moving forward, subsequent versions, 7.1, 7.2 etc., may be released, but will be considered only as updates within the seventh version, with improved precision of the mandates and test methods.

Citing from these criteria (e.g. in procurement contracts) is permitted, provided that the source is disclosed and the extent of the quotation is consistent with sound copyright practice. For further information, please visit [www.tcodevelopment.com](http://www.tcodevelopment.com).

TCO Development, Stockholm, November, 2015

# A Criteria

## A.1 General information

This document contains requirements, test methods and references for Flat Panel Displays, herein referred to as “FPD” throughout.

### **Flat Panel Display definition**

This means Visual Display Units (VDUs) of LCD and OLED type. However, the measuring procedures may in many cases be applied to other types of flat panels with fixed positions of the pixels. The term FPD covers the display, the stand and external power supply as it is delivered to the end user, but not any peripherals.

### **Televisions and Large Format Public Displays may also be certified in accordance with this criteria document**

### **Criteria document setup**

The aim of this criteria document is to provide relevant criteria and test methods covering all life cycle phases of the product. Criteria are set so that 30-50% of the products available on the market can pass. This criteria document consists of two parts; Part A- the mandated criteria and Part B - clarifications and test methods.

### **Compliance**

Compliance with the mandates in this document can be achieved in one of two ways; either through a test report or through a verification report. Compliance methods can vary by criterion and are specified under each mandate.

1. A test report is defined as a report based on:
  - Testing conducted by the facility issuing the test report for the product identified in the report.
2. A verification report is defined as a summary report and a verdict (pass or fail) based on either:
  - A test report issued by the same facility
  - A test report issued by a different facility.
  - Declarations, certificates or other proof from the Company or Brand owner applying for the certificate.

The options accepted by TCO Development for each criterion can be found under each mandate.

## A.1.1 Information to End-Users

### Background

It is important that the purchaser of a product that has been certified in accordance with TCO Certified Displays receives information concerning the sustainability features of the product. This information, contained in the TCO Certified Document, is developed and provided by TCO Development.

### Applicability

All FPDs.

### Life Cycle Phases



### Clarification

[See B.1.1](#)

### References

The contract between TCO Development and the Applicant/Brand owner.



**Mandate A.1.1:**

An information document called “TCO Certified Document” provided by TCO Development shall accompany the product to describe why these particular criteria have been chosen for the products within the TCO Certified program, and what is expected to be achieved by them. The document shall be written in English or the native language where the product is to be sold.

Examples of how the document can accompany the product:

- As a separate printed document.
- As a digital file or printed in the user manual.
- As a direct link from the user manual or digital file to the document on the manufacturer’s web site.

**Submit the following to an approved verifier:**

1. Information on how the TCO Certified Document accompanies the product
2. A written guarantee that the above mandate is fulfilled. The document shall be signed by the responsible person at the applicant company.

**Submit the following together with the application to TCO Development:**

A copy of a verification report from a test facility approved by TCO Development.

We hereby guarantee that the above mandate is fulfilled.

.....  
Product brand name

.....  
Model name(s)

.....  
Signature

.....  
Name and title in block capitals

.....  
Date

.....  
Company

## A.2 Visual ergonomics

Good visual ergonomics is a very important aspect of quality that can also have a direct effect on the health, comfort and performance of the user. Good ergonomics, such as a high quality display image, can also influence our productivity and extend the usable life of a product. In this way, ergonomic design can also offer sustainability benefits.

In developing criteria for visual ergonomics, the possible health effects of various parameters have been taken into account. Other features that characterise high quality displays have also been in focus when developing these criteria.

TCO Development used three main methodologies to determine suitable levels and test methods for the visual ergonomics criteria:

1. Acceptable visual levels, as determined by scientific research.
2. Statistics from tests carried out in accordance with TCO Development, ISO, MPR regulations and from specialized VDU tests.
3. Manufacturers' knowledge and experience, which is invaluable. Manufacturers, consumer groups and other organisations with interests in the visual ergonomics field have contributed a great deal of valuable information and ideas throughout the development process.

### Life Cycle Phase



## **A.2.1 Image detail characteristics**

### **A.2.1.1 Native display resolution requirement**

#### **Background**

Image quality is negatively affected by a low fill factor, visible “jaggies”, poor rendering of details, etc. All of these parameters are related to the resolution of the display. For display resolution characteristics, it is important to take the viewing distance into account.

The viewing distance in this criteria document is defined as  $1.5 \times$  the display diagonal, but no less than 500 mm, which could be considered an absolute minimum viewing distance for comfortable viewing. This means that the mandate on resolution is independent of the display size and viewing distance but dependent on the aspect ratio. Only the aspect ratio needs to be known.

#### **Definition**

A pixel is the smallest addressable imaging element of the FPD capable of reproducing a full range of luminance and colours.

The native display resolution is the number of pixels in the horizontal direction by the number of pixels in the vertical direction that the display can present.

#### **Applicability**

All FPDs.

#### **Test procedure**

[See B.2.1.1.](#)

#### **References**

2, 36 and 44.

**Mandate A.2.1.1:**

The pixel density shall be  $\geq 30$  pixels/degree visual angle

**Submit the following together with the application to TCO Development:**

A copy of a test report and a verification report from a test facility approved by TCO Development.

## **A.2.2 Luminance characteristics**

### **A.2.2.1 Luminance level**

#### **Background**

It shall be possible to set the luminance level according to the lighting conditions of the surroundings. Poor luminance can lead to low contrast and consequently affect legibility and colour discrimination and thus lead to misinterpretations. It shall be possible to set a sufficiently high and low luminance levels with respect to the ambient lighting in order to present a comfortable viewing situation and to avoid eyestrain.

#### **Definition**

Luminance being emitted from a particular area is a measure of the luminous intensity per unit area of light travelling in a given direction and falls within a given solid angle.

The unit of luminance is  $\text{cd/m}^2$ .

#### **Applicability**

All FPDs.

#### **Test procedure**

[See B.2.2.1.](#)

#### **References**

1, 2, 18, 21, 27, 31, 36 and 44.

#### **Mandate A.2.2.1:**

**The following conditions shall be fulfilled:**

- The luminance at default setting shall be  $\geq 150 \text{ cd/m}^2$
- The maximum luminance shall be  $\geq 200 \text{ cd/m}^2$
- The minimum luminance shall be  $\leq 100 \text{ cd/m}^2$

**Submit the following together with the application to TCO Development:**

A copy of a test report and a verification report from a test facility approved by TCO Development.

### A.2.2.2 Luminance uniformity

#### Background

When poor luminance uniformity is visible, it can locally affect the contrast and consequently the legibility of information on the display. The areas of deviating luminance can have different sizes and cause varying contour sharpness.

#### Definition

Luminance uniformity is the capacity of the FPD to maintain the same luminance level over the whole active screen area. The luminance uniformity is defined as the ratio of maximum to minimum luminance within the fully active screen area.

#### Applicability

All FPDs.

#### Test procedure

[See B.2.2.2.](#)

#### References

1, 2, 16, 18, 21, 22, 27, 32, 33, 36 and 44.

**Mandate A.2.2.2:**

Luminance variation across the active screen,  $L_{\max} : L_{\min}$  shall be  $\leq 1.50$

**Submit the following together with the application to TCO Development:**

A copy of a test report and a verification report from a test facility approved by TCO Development.

### A.2.2.3 Black level

#### Background

It is important that a display can produce a black level dark enough to show shadow details in pictures at high and low white luminance levels.

#### Definition

Black level is the capacity of the display to maintain a good reproduction of black even when its luminance is high.

#### Applicability

All FPDs.

#### Test procedure

[See B.2.2.3.](#)

#### References

51

**Mandate A.2.2.3:**

The luminance of black shall be  $\leq 2 \text{ cd/m}^2$  at a white luminance setting of  $\geq 200 \text{ cd/m}^2$ .

**Submit the following together with the application to TCO Development:**

A copy of a test report and a verification report from a test facility approved by TCO Development.

#### A.2.2.4 Luminance uniformity - angular-dependence

##### Background

The luminance of an FPD is angular-dependent, i.e. screen luminance decreases when the FPD is viewed slightly from the side, either horizontally or vertically. This can have a negative effect on contrast and can affect the legibility of the display.

##### Definition

Luminance uniformity – angular dependence, is the capacity of the FPD to maintain a certain luminance level independently of the viewing direction. The angular-dependent luminance uniformity is defined as the ratio of maximum luminance to minimum luminance in the specified measurement areas.

##### Applicability

All FPDs.

##### Test procedure

[See B.2.2.4.](#)

##### References

1, 16, 22, 27, 31, 32 and 33.

##### **Mandate A.2.2.4:**

- 1) In landscape mode, when the screen is rotated around the vertical axis through the centre of the screen the mean value of the  $L_{\max}$  to  $L_{\min}$  ratios at  $\pm 30^\circ$  shall be  $\leq 1.73$ .
- 2) In landscape mode, when the screen is rotated around the horizontal axis through the centre of the screen, the largest value of the  $L_{\max}$  to  $L_{\min}$  ratios at  $\pm 15^\circ$  shall be  $\leq 1.73$ .

##### **Submit the following together with the application to TCO Development:**

A copy of a test report and a verification report from a test facility approved by TCO Development.

### A.2.2.5 Greyscale gamma curve

#### Background

A calibrated gamma curve makes it easier to distinguish between similar light levels. A well-tuned greyscale is the basis for accurate detail rendering of any imaging device. The greyscale rendering is measured via a number of steps in a greyscale in the test image. Each greyscale step, regardless of grey level, shall have a luminance level close to what is specified by the common standard sRGB in order to give accurate rendering of the greyscale of the original image. With special software or hardware calibration tools it may be possible to achieve a better calibrated gamma curve than the TCO Certified criteria and also in other presets than the default one.

#### Definition

Greyscale gamma curve is the capability of the imaging device to maintain the original greyscale luminance or a greyscale pattern at all tested greyscale levels.

#### Applicability

All FPDs.

#### Test procedure

[See B.2.2.5](#)

#### References

11, 12, 13, 14, 20, 51, 52 and 72.

#### Mandate A.2.2.5:

The different grey scale luminance levels shall be within the Max- and Min levels according to the table below, where 100% means the luminance level measured for white, RGB 255, 255, 255.

Grey level	$L_{sRGB}$ %	$L_{min}$ %	$L_{max}$ %
255	100	100,0	100,0
225	75	70	93
195	55	46	68
165	38	29	49
135	24	17	36
105	14	8	24
75	7	3	14
45	3	1	7

**Submit the following together with the application to TCO Development:**

A copy of a test report and a verification report from a test facility approved by TCO Development.



## A.2.3 Luminance contrast characteristics

### A.2.3.1 Luminance contrast – characters

#### Background

The degree of contrast is important for legibility and for distinguishing one character from another.

#### Definition

Luminance contrast – characters is the capacity of the FPD to maintain a high luminance difference between a bright background and dark characters or parts of characters over the whole active area.

Luminance contrast – characters is expressed as the ratio of the  $L_{\max}$  to  $L_{\min}$  difference over the sum of  $L_{\max}$  and  $L_{\min}$ , in accordance with Michaelson's formula.

#### Applicability

All FPDs.

#### Test procedure

[See B.2.3.1.](#)

#### References

2, 16, 19, 20, 22, 23, 27, 32 and 44.

#### **Mandate A.2.3.1:**

**The luminance contrast shall be  $\geq 0.70$  measured orthogonally to the screen.**

**Submit the following together with the application to TCO Development:**

**A copy of a test report and a verification report from a test facility approved by TCO Development.**

### **A.2.3.2 Luminance contrast – angular dependence**

#### **Background**

For FPDs the luminance and consequently the contrast on the display is angular-dependent. The luminance variations can influence both the bright white and the dark areas of the screen, causing a change in contrast. This can have a negative effect on the legibility of the display.

#### **Definition**

Luminance contrast – angular dependence, is the capability of the FPD to maintain the same contrast regardless of the direction from which the screen is viewed.

Luminance contrast – angular dependence, is expressed as the ratio of the  $L_{\max}$  to  $L_{\min}$  difference over the sum of  $L_{\max}$  and  $L_{\min}$ , in accordance with Michaelson's formula. It is measured at two different angles.

#### **Applicability**

All FPDs.

#### **Test procedure**

[See B.2.3.2.](#)

#### **References**

2, 16, 19, 20, 23, 28 and 33.

#### **Mandate A.2.3.2:**

**In landscape mode, the luminance contrast-angular dependence shall be  $\geq 0.80$  at  $\pm 30^\circ$  horizontally from the viewing direction (rotated around the vertical axis through the centre of the screen).**

**Submit the following together with the application to TCO Development:**

**A copy of a test report and a verification report from a test facility approved by TCO Development.**

## A.2.4 Screen colour characteristics

### A.2.4.1 Correlated colour temperature, CCT, variation

#### Background

Most FPDs are today equipped with a number of pre-set correlated colour temperature settings. These settings make it possible to more accurately evaluate the colour of an image on the FPD compared to real scenes or prints.

Physical measurements of colour stimuli can only give an indication of the colour appearance in a practical situation. The colour of the frame, the spectral composition of the lighting, the colour of various areas in the visual field, and the complexity of brightness variations in the visual field all influence the colour appearance of an FPD image.

Normal daylight has a correlated colour temperature in the range 5000 – 10000 K.

For the editing of photos or video, it is important to be able to set a colour temperature of 6500 K or sRGB, since most productions are made using that standard.

#### Definition

The correlated colour temperature is a measure of the perceived screen colour expressed in kelvin (K).

#### Applicability

All FPDs.

#### Test procedure

[See B.2.4.1.](#)

#### References

2, 3, 4, 8-12, 14, 15, 17, 24, 25, 26, 28, 30, 34, 36 and 38.

#### **Mandate A.2.4.1:**

**The FPD shall have at least two predefined possibilities for pre-set correlated colour temperatures between 5000K and 10000K and one possibility for the user to adjust the CCT (total of three settings).**

**Each pre-set correlated colour temperature shall have a colour difference  $\Delta u'v' \leq 0.012$  when compared to CIE  $u'$  and  $v'$  chromaticity co-ordinates for corresponding correlated colour temperatures.**

**Submit the following together with the application to TCO Development:**

**A copy of a test report and a verification report from a test facility approved by TCO Development.**

#### A.2.4.2 Colour uniformity

##### Background

The human visual system is very sensitive to changes in colour hue in white and grey areas. Since the white or grey colour hues are the background on which most colours are judged, the white or grey areas are the reference colours on the screen.

Patches of colour variation on an active white or grey screen could reduce the contrast locally, be disturbing and affect the legibility, colour rendering and colour differentiation.

##### Definition

The colour uniformity of an FPD is the capability to maintain the same colour on any part of the screen.

##### Applicability

All FPDs.

##### Test procedure

[See B.2.4.2.](#)

##### References

2, 8, 14, 15, 23, 25, 29, 35, 36 and 38.

**Mandate A.2.4.2:**

The maximum colour deviation between measured active areas on the screen that are intended to maintain the same colour shall be  $\Delta u'v' \leq 0.012$ .

**Submit the following together with the application to TCO Development:**

A copy of a test report and a verification report from a test facility approved by TCO Development.

### A.2.4.3 RGB settings

#### Background

Accurate colour rendering is important when realistic colour images or colour presentations are presented on the FPD screen. Poor colour rendering can lead to poor legibility and misinterpretation. The  $u'$  and  $v'$  chromaticity co-ordinates of the primary colours red (R), green (G) and blue (B) of the screen shall aim at values given in international IEC, EBU and ITU standards. The  $u'$  and  $v'$  chromaticity co-ordinates of the primary colours R, G and B form a triangle in the CIE 1976 uniform chromaticity scale diagram. The larger the area of the triangle, the more saturated and the wider the range of colours the screen is capable of presenting if the same numbers of colour bits are used. The relative colour gamut calculation in this document is expressed as a percentage of the total CIE 1976 uniform chromaticity scale diagram. However, it is also important that the  $u'$  and  $v'$  for red, green and blue are accurate enough to present as true colours as possible.

#### Definition

The colour characteristics of an FPD are based on the visual appearance of the FPD primary colour stimuli, the R, G, B-stimuli. The colour gamut of a device or process is that portion of the colour space that can be represented or reproduced.

#### Applicability

All FPD s.

#### Test procedure

[See B.2.4.3.](#)

#### References

3, 4, 8-15, 17, 25, 26, 28, 30, 34, 36 and 38.

#### Mandate A.2.4.3:

The following mandates shall be met:

1. The minimum colour triangle shall be  $\geq 29\%$
2. The following tolerances to the sRGB coordinates:

	Red		Green		Blue	
Co-ordinate	$u'$	$v'$	$U'$	$v'$	$u'$	$v'$
Requirement	$\geq 0.411$	$\geq 0.503$	$\leq 0.140$	$\geq 0.548$	$\geq 0.150$	$\leq 0.210$

#### Submit the following together with the application to TCO Development:

A copy of a test report and a verification report from a test facility approved by TCO Development.

#### **A.2.4.4 Colour uniformity – angular dependence**

##### **Background**

The human visual system is very sensitive to changes in colour hue in white and grey areas. Since the white or grey colour hues are the background on which most colours are judged, the white or grey areas are the reference colours on the screen. Angular-dependent colour variations on an active white or grey screen could be disturbing and affect legibility, colour rendering and colour differentiation.

##### **Definition**

The colour uniformity – angular dependence of an FPD is the capability of the display to maintain constant colour over the screen surface depending of the direction from which the screen is viewed.

##### **Applicability**

All FPDs.

##### **Test procedure**

[See B.2.4.4.](#)

##### **References**

2, 8, 14, 15, 23, 25, 29 and 35.

##### **Mandate A.2.4.4:**

In landscape mode, the  $\Delta u'v'$  between areas on the left side and the right side of the screen when it is positioned at  $+30^\circ$  and at  $-30^\circ$  horizontally to the screen normal (rotated around the vertical axis through the centre of the screen) shall be  $\Delta u'v' \leq 0.025$ .

##### **Submit the following together with the application to TCO Development:**

A copy of a test report and a verification report from a test facility approved by TCO Development.

### A.2.4.5 Colour greyscale linearity

**Background**

A well-tuned colour greyscale is the basis for good colour rendering on the screen. This is measured via steps in a greyscale on the screen. Each greyscale step shall have similar colour hues in order to simplify colour interpretation and to avoid confusion for the user, only the luminance shall vary.

**Definition**

Colour greyscale linearity is the capability of the screen to maintain the same u',v' coordinates of a greyscale pattern at all greyscale levels, i.e. only the luminance shall change from one greyscale step to the next.

**Applicability**

All FPDs.

**Test procedure**

See [B.2.4.5](#).

**References**

2, 8, 14, 15, 23, 25, 29 and 35.

**Mandate A.2.4.5:**

**Table A.2.4.5**

Greyscale	Maximum $\Delta u'v'$ difference							
	255	225	195	165	135	105	75	45
255	0							
225	0.015	0						
195	0.015	0.015	0					
165	0.020	0.020	0.020	0				
135	0.025	0.025	0.020	0.020	0			
105	0.025	0.025	0.025	0.025	0.020	0		
75	0.035	0.035	0.035	0.035	0.035	0.025	0	
45	0.035	0.035	0.035	0.035	0.035	0.035	0.035	0

The  $\Delta u'v' \leq$  the maximum allowed difference for each step according to table A.2.4.5.

**Submit the following together with the application to TCO Development:**

A copy of a test report and a verification report from a test facility approved by TCO Development.

## A.3 Workload Ergonomics

Workload ergonomics refers to the adaptation of the tasks, tools, workspace and physical environment where the product will be used. These criteria are put in place in order to meet the user's needs for a good work environment.

Electronic devices are, just like furniture, lighting and other equipment, an important part of the modern workspace. TCO Development wants to contribute to the development of FPDs that feature good user characteristics, based on the principles of good workload ergonomics. Ergonomic design enhances the possibility for users to be able to have good quality FPDs that allow for physical variation.

It is important that FPDs offer users the possibility of variation in work posture. An aesthetically appealing design should not restrict ergonomic function.

Displays larger than 26" are not normally used on a typical workspace. They are also not considered to be easily movable on a normal display stand but are often placed on wall mounts. They are therefore excluded from the A.3 Workload Ergonomics criteria. Some displays are sold without any kind of stand device. This can be in order to mount the display on walls or on a custom VESA compatible stand by the end user. Such displays are also excluded from A.3 Workload Ergonomics criteria.

### Life Cycle Phase





## A.3.1 Vertical tilt

### Background

It is beneficial to be able to tilt the FPD in the vertical plane. This creates the possibility to tilt the FPD back and achieve a 90 degree viewing angle. This offers the user the option of altering work posture for maximum comfort and also to obtain the best visual ergonomics of the FPD.

### Applicability

All FPDs  $\leq 26''$  that are delivered with a stand.

### Clarification

[B.3.1](#)

### References

39-48.

#### **Mandate A.3.1:**

**FPD's  $\leq 26''$  shall achieve a backwards tilt of at least 20 degrees in the vertical plane.**

#### **Submit the following to the verifier at the test facility:**

**A written guarantee that the above mandate is fulfilled. The guarantee shall be signed by the responsible person at the applicant company.**

#### **Submit the following together with the application to TCO Development:**

**A copy of a verification report from a test facility approved by TCO Development.**

We hereby guarantee that the above mandate is fulfilled.

.....  
Product brand name

.....  
Model name(s)

.....  
Signature

.....  
Name and title in block capitals

.....  
Date

.....  
Company

## A.3.2 Vertical height

### Background

For long-term display use, a straight or slightly downward viewing angle is important for maintaining good posture and visual comfort. This is especially important for users with bifocal glasses who will be forced to tilt the head backwards if the display is positioned too high. Therefore it is beneficial that the top of the active display area is not above the normal line of sight ( $0^\circ$  -  $15^\circ$  below horizontal) so users will not need to extend the neck backwards to look at the FPD when it is placed on a standard height (750 mm) table. A height adjustment function is recommended in order to allow for work posture flexibility as well as achieving optimal visual ergonomics of the FPD.

### Applicability

All FPDs  $\leq 26''$  that are delivered with a stand.

### Clarification

[B.3.2](#)

### References

39-49, 73 and 74.

#### **Mandate A.3.2:**

**FPD's  $\leq 26''$  shall meet at least one of the following mandates:**

- 1- With the display aligned vertically in its lowest point of height adjustment, the distance measured from the underside of the display's foot (work top surface) to the upper edge of the active screen area shall be  $\leq 42$  cm.
- 2- The FPD shall have a mounting interface applicable to the VESA mounting interface standard.

#### **Submit the following to the verifier at the test facility:**

A written guarantee that the FPD meets the above mandate. The guarantee shall be signed by the responsible person at the applicant company.

#### **Submit the following together with the application to TCO Development:**

A copy of a verification report from a test facility approved by TCO Development.

We hereby guarantee that the above mandate is fulfilled.

.....  
Product brand name

.....  
Model name(s)

.....  
Signature

.....  
Name and title in block capitals

.....  
Date

.....  
Company

## A.4 Emissions

Users of IT equipment increasingly have several nearby electrical and magnetic field sources placed on work surfaces that they are exposed to. When the first TCO certification for IT products was introduced in 1992, one of the main interests was the criteria for reducing electrical and magnetic fields. To this day scientists and experts are divided on the question of whether these fields pose any risks to human health.

Due to continued public concern and the increasing amount of emissions surrounding us, TCO Development remains convinced that the criteria in TCO Certified are still relevant, even with today's slimline, low emissions products. TCO Certified emissions criteria are intended to make certain that internal shielding is used to ensure that a TCO Certified product's emissions are at a technically achievable low level and will not raise normal background levels when the product is used in a working environment.

TCO Certified criteria cover emissions around the product since it may be placed near other persons working in close proximity.

Some FPDs are sold without any kind of stand device. This can be in order to mount the display on a wall or on a custom VESA compatible stand by the end user. The type of stand may have a big impact on the measurements of the alternating electric and magnetic field. As it is impossible to know the actual type of stand the end user will choose it is not possible to set up a test condition that represents the real situation. Because of this such FPDs are excluded from the criteria on alternating electric and magnetic fields.

Many people find acoustic noise annoying and especially high-pitched noise. To prevent annoyance TCO Development sets requirements to limit the noise from products with integrated fans.

### Life Cycle Phase



## A.4.1 Alternating electric fields

### Background

Electrical alternating fields are created between objects that have different levels of electrical potential that change over time. When the potential changes in a periodic manner, an electrical alternating field is set up, with a field strength and a frequency. An IT product can contain many sources of electrical alternating fields. The field characteristics depend on the actual electrical potential difference and the distance from the product.

Some users are concerned about a possible health risk arising from electrical alternating fields generated by IT products. The mandatory criteria are aimed at reducing the electrical alternating fields to such a low level so as not to burden the work and home environment with unnecessary factors. The mandatory criteria shall not be regarded as hygienic limit values.

### Applicability

All FPDs that are delivered with a stand.

### Test procedure

[See B.4.1.](#)

#### **Mandate A.4.1:**

##### **Band I: 5 Hz to 2 kHz, $\leq 10$ V/m**

FPDs  $\leq 26''$  are measured at 0.30 m and 0.50 m in front of the FPD.

FPDs  $> 26''$  are measured at 0.50 m in front of the FPD.

##### **Band II: 2 kHz to 400 kHz, $\leq 1.0$ V/m**

FPDs  $\leq 26''$  are measured at 0.30 m in front of- and 0.50 m around the FPD.

FPDs  $> 26''$  are measured at 0.50 m from the surface of the product around the FPD.

#### **Submit the following together with the application to TCO Development:**

A copy of a test report and a verification report from a test facility approved by TCO Development.

## A.4.2 Alternating magnetic fields

### Background

Magnetic alternating fields are created when an electrical alternating current flows through a conductor. IT products are surrounded by magnetic alternating fields that are generated by different parts of the product, e.g. power supply unit, voltage inverters and other electrical circuits. The field strength depends on the actual electric current and on the distance from the product.

Some users are concerned about a possible health risk arising from electrical alternating fields generated by IT products. The mandatory criteria are aimed at reducing the magnetic alternating fields to such a low level as not to burden the work and home environment with unnecessary factors. The mandatory criteria shall not be regarded as hygienic limit values.

### Applicability

All FPDs that are delivered with a stand.

### Test procedure

[See B.4.2.](#)

**Mandate A.4.2:****Band I: 5 Hz to 2 kHz,  $\leq 200$  nT**

FPDs  $\leq 26''$  are measured at 0.30 m in front of- and at 0.50 m around the FPD.

FPDs  $> 26''$  are measured at 0.50 m from the surface of the product around the FPD.

**Band II: 2 kHz to 400 kHz,  $\leq 25$  nT**

FPDs  $\leq 26''$  are measured at 0.50 m around the FPD.

FPDs  $> 26''$  are measured at 0.50 m from the surface of the product around the FPD.

**Submit the following together with the application to TCO Development:**

A copy of a test report and a verification report from a test facility approved by TCO Development.

### **A.4.3 Acoustic Noise**

In the event that the FPD is equipped with integrated moving parts such as a fan, the FPD shall fulfil the criteria for acoustic noise as found in the latest version of the criteria document for TCO Certified All-in-One PCs. This criteria document can be found on the TCO Development web page: [www.tcodevelopment.com](http://www.tcodevelopment.com).

## A.5 Electrical safety

### A.5.1 Electrical safety

#### Background

Electrical safety concerns the electrical design of apparatus with respect to its electrical insulation and other arrangements that are intended to prevent accidents resulting from contact with live components, and the risk of fire or explosion as a result of electrical flash-over due to inadequate or faulty electrical insulation.

#### Applicability

All FPDs with built-in power supplies as well as any external power supply intended to be used together with the FPD.

#### Life Cycle Phase



#### References

50.

#### **Mandate A.5.1:**

The FPD and external power supply/supplies shall be certified according to EN/IEC 60950 or EN/IEC 60065 or [EN/IEC 62368-1](#).

**Submit the following together with the application to TCO Development:**

A copy of the CB certificate or a national certificate from a CB member (NCB).

## A.6 Environment

This section details the environmental criteria in TCO Certified, which offer a unique, integrated balance of environmental issues in the manufacturing, use and end of life phases of the product.

The environmental criteria are divided into the following sections:

1. Manufacturing – criteria focusing on the manufacturing phase and environmental management
2. Climate – energy consumption, one of the most important issues in the environmental impact of IT products.
3. Hazardous Substances – heavy metals, flame retardants, plastics.
4. Material resource efficiency – factors to extend the life of the product and influence better use of material resources.
5. End of life – factors to stimulate recycling and minimize the impact of e-waste.

Potential environmental effects are evident at each stage of the product life cycle. The environmental criteria TCO Development has focused on in this document are those that we consider most relevant to the product group. They have also proved to be attainable in volume manufacturing and are verifiable.

Compliance with these criteria (except section A.6.3 *Climate*) is verified by sending the requested information to a verifier approved by TCO Development. The energy consumption requirements in section A.6.3 shall be tested at a test facility approved by TCO Development or an EPA approved test facility.

### Life Cycle Phases





## A.6.1 Product description

### Background

The aim of this product description is to provide third party verified information about the product. The information is used by TCO Development to verify that the product complies with the criteria in TCO Certified.

The information is also provided on the certificate to buyers so that it helps them calculate the sustainability impact of the products and the benefit of buying products that fulfil TCO Certified.

Using the declared sustainability information a buyer can, for example, implement climate compensation or other sustainability-related measures connected to the sustainability impact of the product. This data is often used by organisations in their annual sustainability report or internal programs aimed at minimizing the environmental impact of IT.

### Definition

*Recycled plastic* is post-consumer recycled plastic that has been used in products.

*Plastic parts* are all product parts made out of plastic except panels, electronic components, cables, connectors, PWBs, insulating mylar sheets and labels. This is primarily due to insufficient available alternatives. This also means that the weight of these items is not included when calculating the total weight of the plastic in the product in this requirement.

*Marking plate /Marking label* is the label that contains the product's electrical rating in terms of voltage, frequency, current and the manufacturer's name, trademark or identification mark together with the manufacturer's model or type reference. The label shall be in accordance with IEC 60 950:1 clause 1.7.1.

### Applicability

All FPDs.

### Life Cycle Phases



### Clarification

[B.6.1](#)

### References

53.

**Mandate A.6.1:**

A product declaration shall be provided for the FPD. The following information shall be verified by the third party facility and is printed by TCO Development on the certificate.

**Submit the following to an approved verifier:**

1. The declaration below, completed where applicable.
2. A copy of the marking label for the FPD and any external power supply.

The information submitted shall be signed by the responsible person at the applicant company.

**Submit the following together with the application to TCO Development:**

A copy of a verification report including all information in the table below from a verifier approved by TCO Development and a copy of the marking label.

**FPD Declaration**

<b>Display</b>	
Manufacturer	
Brand name	
Brand Owner	
Type/Model name	
Screen size (inch)	

<b>Panels</b>	
Manufacturer	
Type/Model name	
Brand name	
Technology	

**External power supplies**

Brand & model name	Rating & Class

**Declared sustainability information**

Percentage of <i>recycled plastic</i> by weight of total weight of plastic parts	
Total weight of the product and power supply (without packaging) in Kg	
Measured energy consumption according to Energy Star. <i>(This measured value of one sample may differ from declared values presented in other places due to a batch uncertainty that is normally added to cover all products leaving the production line.)</i>	On mode
	Sleep mode
	Off mode

We hereby guarantee that the above mandate is fulfilled.

..... Product brand name	..... Model name(s)
..... Signature	..... Name and title in block capitals
..... Date	..... Company

## A.6.2 Manufacturing

### A.6.2.1 Environmental management system certification

#### Background

A certified environmental management system shows that the company has chosen to work in a systematic way with constant improvement of the environmental performance of the company and its products. A certified environmental management system includes external independent reviews.

#### Definitions

*Manufacturing plant:* Manufacturing facility where the final assembly of the TCO Certified product takes place.

#### Applicability

The company or companies that manufacture the FPD.

#### Life Cycle Phase



#### Clarification

[B.6.2.1](#)

#### References

54 and 55.

**Mandate A.6.2.1:**

Each *manufacturing plant* must be certified in accordance with ISO 14001, or EMAS registered. If the product is manufactured by a third party, it is this company that shall be certified or registered.

**Submit the following to an approved verifier:**

1. A document showing the names and addresses of the manufacturing plants.
2. Copy of the ISO 14001 certificate or EMAS registration from each manufacturing plant.
3. A written guarantee that the certificate/registration is valid and that the mandate above is fulfilled, signed by the responsible person at the applicant company.

**Submit the following together with the application to TCO Development:**

A copy of a verification report from a verifier approved by TCO Development.

We hereby guarantee that the above mandate is fulfilled.

.....  
Product brand name

.....  
Model name(s)

.....  
Signature

.....  
Name and title in block capitals

.....  
Date

.....  
Company

## A.6.3 Climate

### A.6.3.1 Energy consumption

#### Background

Energy is the single most important topic in the issue of climate change. Energy efficient equipment is an important and effective way to fight climate change. With an ever-increasing volume of IT equipment in use, the efficiency of each product is vital.

#### Applicability

All FPDs.

#### Life Cycle Phase



#### Clarification

[B.6.3.1](#)

#### References

60.

#### **Mandate A.6.3.1:**

**The energy consumption requirements in the most recently published Energy Star® standard for displays on the date of application shall be fulfilled and verified through testing by a test facility approved by TCO Development or at any EPA approved test facility accredited according to ISO17025.**

#### **Submit the following together with the application to TCO Development:**

**A copy of a test report and a verification report from a test facility approved by TCO Development.**

### A.6.3.2 Energy consumption – external power supply

#### Background

Energy is the single most important topic in the issue of climate change. Energy efficient equipment is an important and effective way to fight climate change. With an ever-increasing volume of IT equipment in use, the efficiency of each product is vital. To reduce energy consumption of the product the external power supply shall comply with the International Efficiency Marking Protocol for External Power Supplies.

#### Applicability

All external power supplies.

#### Clarification

[B.6.3.2](#)

#### References

61.

**Mandate A.6.3.2:**

The external power supply shall meet at least the International Efficiency Protocol requirement for level V.

**Submit the following to the verifier at the test facility:**

A copy of the marking label for the external power supply

**Submit the following together with the application to TCO Development:**

A copy of the marking label for the external power supply

## A.6.4 Hazardous substances

### A.6.4.1 Cadmium (Cd), mercury (Hg), lead (Pb) and hexavalent chromium (CrVI)

#### Background

The effects of cadmium, mercury, lead and hexavalent chromium are well documented as substances hazardous both to our health and the environment. Electronic devices contain hazardous substances like heavy metals and brominated flame retardants. This may cause problems, both in the manufacturing phase where workers or the environment can get exposed, in the use phase (additives can leak from the plastic and accumulate in dust, harming both our health and the environment) and at end of life, where uncontrolled recycling can cause the release of toxins such as dioxins and furans.

This criterion is harmonized with EU RoHS2 Directive (2011/65/EU), except that TCO Certified does not allow mercury in the display panel backlight. As TCO Certified is a global label this also affects products sold outside the EU.

#### Applicability

All FPDs.

#### Life Cycle Phase



#### Clarification

[B.6.4.1](#)

#### References

62 and 63.



**Mandate A.6.4.1:**

The FPD shall not contain cadmium, mercury, lead and hexavalent chromium.

**Submit the following to an approved verifier:**

A written guarantee that the above mandate is fulfilled. The guarantee shall be signed by the responsible person at the applicant company.

**Submit the following together with the application to TCO Development:**

A copy of a verification report from a verifier approved by TCO Development.

We hereby guarantee that the above mandate is fulfilled.

..... Product brand name	..... Model name(s)
..... Signature	..... Name and title in block capitals
..... Date	..... Company

## A.6.4.2 Halogenated substances

### Background

Halogenated flame retardants and plasticizers are often persistent, can bio-accumulate in living organisms and have been detected in both humans and the environment. These substances may be problematic in the manufacturing and end of life phases where workers or the environment can be exposed. They can also migrate from the products during the use phase with unknown health effects as a result.

### Definitions

*Plastic parts* are parts made mainly of plastics, e.g. the housing. Parts containing other materials in any significant amounts, e.g. cables with metal conductors, are not included in the definition.

*Printed wiring board laminate* is a printed board that provides point-to-point connections but not printed components in a predetermined configuration on a common base.

*Halogens* are a group of five chemically related non-metallic elements in the Periodic Table; fluorine, chlorine, bromine, iodine and astatine.

Polybrominated biphenyls (*PBB*) and Polybrominated diphenyl ethers (*PBDE*) are restricted in the RoHS directive (2002/95/EC) due to the hazardous properties of these substances. Hexabromocyclododecane (*HBCDD*) has been identified as a Substance of Very High Concern in accordance with EU REACH criteria due to PBT (persistent, bio accumulative, toxic) properties.

### Applicability

All FPDs.

### Clarification

[B.6.4.2](#)

### References

64.

**Mandate A.6.4.2:**

1. *Plastic parts* weighing more than 25 grams shall not contain flame retardants or plasticizers that contain halogenated substances.

**Note:** This applies to plastic parts in all assemblies and sub-assemblies. Exempted are *printed wiring board laminates*, electronic components and all kinds of cable insulation.

2. The FPD shall not contain PBB, PBDE and HBCDD.

**Note:** This applies to components, parts and raw materials in all assemblies and sub-assemblies of the product e.g. batteries, paint, surface treatment, plastics and electronic components.

**Submit the following to an approved verifier:**

A written guarantee that the above mandate is fulfilled. The guarantee shall be signed by the responsible person at the applicant company.

**Submit the following together with the application to TCO Development:**

A copy of a verification report from a verifier approved by TCO Development.

We hereby guarantee that the above mandate is fulfilled.

..... Product brand name	..... Model name(s)
..... Signature	..... Name and title in block capitals
..... Date	..... Company

### A.6.4.3 Non-halogenated substances

#### Background

The purpose of this mandate is to increase the knowledge of substances with regards to their human and environmental impacts and to drive a shift towards less hazardous alternatives. These substances may be problematic in the manufacturing and end of life phase where workers or the environment can get exposed and can also migrate from the products during the use phase with unknown health effects as a result.

The mandate uses the hazard assessment and decision logic framework called GreenScreen™ for Safer Chemicals developed by the non-profit organization Clean Production Action (CPA). The GreenScreen methodology can be used for identifying substances of high concern and safer alternatives.

The GreenScreen criteria are in line with international standards and regulations including the Globally Harmonized System of Classification and Labelling of Chemicals (GHS), OECD testing protocols and the European REACH Regulation. The U.S. EPA's Design for Environment (DfE) Alternatives Assessment is also an important influence on the GreenScreen™ for Safer Chemicals.

#### Definitions

*Plastic parts* are parts made mainly of plastics, e.g. the housing. Parts containing other materials in any significant amounts, e.g. cables with metal conductors, are not included in the definition.

*Printed wiring board laminate* is a printed board that provides point-to-point connections but not printed components in a predetermined configuration on a common base.

*Licensed Profilers* are organisations approved by CPA with the capacity to provide GreenScreen assessments.

*Accepted substances* are considered the most sustainable alternatives which are possible for the industry to use, also taking into consideration aspects such as availability and functionality. Accepted substances are found on the TCO Development website under "*Accepted Substances list*".

#### Applicability

All FPDs.

#### Clarification

[B.6.4.3](#)

**Mandate A.6.4.3:**

Non halogenated flame retardants used in plastic parts that weigh more than 25 grams shall be on the publically available Accepted Substance List for TCO Certified. This means that the substance has been assessed by a licensed profiler according to GreenScreen™ and been assigned a benchmark score  $\geq 2$

The following acceptance decisions apply to substances given Benchmarks 4, 3, 2, 1 or designated U (undefined):

- 4: Accepted – (Few concerns)
- 3: Accepted – (Slight concern)
- 2: Accepted – (Moderate concern)
- 1: Not accepted - (High concern)
- U: Not accepted - (Unspecified)

All substances of a flame retardant mixture shall be accounted for. Non-accepted components shall not exceed concentration levels of 0.1% by weight of the flame retardant.

Exempted are *printed wiring board laminates*, electronic components and all kinds of cable insulation.

A grace period for the above may be granted, see B.6.4.3 for rules

TCO Development will conduct spot-checks and require full disclosure of the flame retardants, including CAS numbers used in the product to verify that the obligations according to this mandate are fulfilled.

**Submit the following to an approved verifier:**

A written guarantee that the above mandate is fulfilled. The guarantee shall be signed by the responsible person at the applicant company.

**Submit the following together with the application to TCO Development:**

A copy of a verification report from a verifier approved by TCO Development.

We hereby guarantee that the above mandate is fulfilled.

..... Product brand name	..... Model name(s)
..... Signature	..... Name and title in block capitals
..... Date	..... Company

#### **A.6.4.4 Halogenated plastics**

##### **Background**

PVC is by far the most common halogen containing plastic. There are however other plastics that contain halogens in the plastic itself. Halogens are problematic from both a health and environmental perspective throughout the product life cycle and should be phased out.

##### **Definitions**

*Plastic parts* are parts made mainly of plastics, e.g. the housing. Parts containing other materials in any significant amounts, e.g. cables with metal conductors, are not included in the definition.

*Printed wiring board laminate* is a printed board that provides point-to-point connections but not printed components in a predetermined configuration on a common base.

*Halogens* are a group of five chemically related non-metallic elements in the Periodic Table; fluorine, chlorine, bromine, iodine and astatine.

##### **Applicability**

All FPDs.

##### **References**

63 and 67.

**Mandate A.6.4.4:**

*Plastic parts* in the FPD weighing more than 25 grams shall not contain intentionally added halogens as a part of the polymer.

**Note:** *Printed wiring board laminates*, and all kinds of internal and external cable insulation are not considered to be part of *plastic parts* and are therefore not included in the mandate.

**Submit the following to an approved verifier:**

A written guarantee that the above mandate is fulfilled. The guarantee shall be signed by the responsible person at the applicant company.

**Submit the following together with the application to TCO Development:**

A copy of a verification report from a verifier approved by TCO Development.

We hereby guarantee that the above mandate is fulfilled.

.....  
Product brand name

.....  
Model name(s)

.....  
Signature

.....  
Name and title in block capitals

.....  
Date

.....  
Company

**A.6.4.5 Phthalates**

**Background**

Phthalates are substances mainly used as plasticizers. The substances restricted in the mandate are listed as Substances of Very High Concern and are included in REACH Annex XIV classified as toxic to reproduction. These substances are problematic from both a health and environmental perspective throughout the product life cycle and should be phased out.

**Applicability**

All FPDs.

**Clarification**

[B.6.4.5](#)

**References**

5, 6, 75, 76, 77 and 78

**Mandate A.6.4.5:**

The FPD shall not contain Bis (2-ethylhexyl) phthalate (DEHP), Butyl benzyl phthalate (BBP), Dibutyl phthalate (DBP), and Diisobutyl phthalate (DIBP). No parts of the product are exempted.

**Submit the following to an approved verifier:**

A written guarantee that the above mandate is fulfilled. The guarantee shall be signed by the responsible person at the applicant company.

**Submit the following together with the application to TCO Development:**

A copy of a verification report from a verifier approved by TCO Development.

We hereby guarantee that the above mandate is fulfilled.

..... Product brand name	..... Model name(s)
..... Signature	..... Name and title in block capitals
..... Date	..... Company



### A.6.4.6 Hazardous substances in product packaging

**Background**

Packaging constitutes a well-known environmental problem and is regulated in many countries worldwide. Packaging material has a short lifetime and generates large volumes of waste.

There are three main areas of concern, content of hazardous substances, use of resources and transport volume. These banned substances are problematic from both a health and environmental perspective throughout the package life cycle and should be phased out.

**Applicability**

All packaging material.

**Clarification**

[B.6.4.6](#)

**References**

71.

**Mandate A.6.4.6:**

The packaging material shall not contain lead (Pb), cadmium (Cd), mercury (Hg) or hexavalent chromium (Cr6).

Plastic packaging material shall not contain organically bound halogens.

**Submit the following to an approved verifier:**

A written guarantee that the mandate above is fulfilled. The guarantee shall be signed by the responsible person at the applicant company.

**Submit the following together with the application to TCO Development:**

A copy of a verification report from a verifier approved by TCO Development.

We hereby guarantee that the above mandate is fulfilled.

Product brand name	Model name(s)
Signature	Name and title in block capitals
Date	Company

## A.6.5 Material Resource Efficiency

### A.6.5.1 Lifetime extension

#### Background

A longer product lifetime makes a significant positive contribution to more efficient resource use as well as the reduction of air and water pollution. A pre-condition for prolonged lifetime is that the product is of high quality, which is supported by good warranties. Another requirement is the availability of spare parts for a number of years once the product is taken out of production. During this period, products should, where possible, be repaired and not replaced.

#### Definitions

*Brand owner*: The company or organization owning or controlling the *Brand Name*.

*Brand Name*: The name or sign, including but not limited to a trademark or company name, used to identify, amongst users and customers, the manufacturer or seller of a product.

*Product Warranty* is a period where the Brand owner offers to repair or replace broken products during a period of time at no charge.

*Spare parts* are those parts that have the potential to fail during normal use of the product. Product parts whose life cycle usually exceeds the average usual life of the product need not be provisioned as spare parts. When the cost for replacing a broken part (e.g. panel) exceeds the cost of replacing the whole product, then that part need not be considered as a spare part under this mandate.

#### Applicability

All FPDs.

#### Life Cycle Phases



#### Clarification

[B.6.5.1](#)

**Mandate A.6.5.1:**

1. The *brand owner* shall provide a *product warranty* for at least one year on all markets where the product is sold.
2. The *brand owner* shall guarantee the availability of *spare parts* for at least three years from the time that production ceases. Instructions on how to replace these parts shall be available to professionals upon request.

**Submit the following to an approved verifier:**

A written guarantee that the above mandate is fulfilled. The guarantee shall be signed by the responsible person at the *brand owner* company.

**Submit the following together with the application to TCO Development:**

A copy of a verification report from a verifier approved by TCO Development.

We hereby guarantee that the above mandate is fulfilled.

..... Product brand name	..... Model name(s) or "All products"
..... Signature	..... Name and title in block capitals
..... Date (Declaration valid 1 year from date)	..... Brand Owner Company

## A.6.6 End of life

### A.6.6.1 Material coding of plastics

#### Background

Prolonging the life of IT-products by reuse is the best way to minimize the environmental impact of IT-products. But when this is no longer possible it is important to facilitate material recycling of the products. Material coding of plastics aims at making the recycling of plastics easier so that the plastic can be used in new IT equipment.

#### Definitions

*Plastic parts* are parts made mainly of plastics, e.g. the housing. Parts containing other materials in any significant amounts, e.g. cables with metal conductors, are not included in the definition.

*Printed wiring board laminate* is a printed board that provides point-to-point connections but not printed components in a predetermined configuration on a common base.

#### Applicability

All FPDs.

#### Life Cycle Phase



#### Clarification

[B.6.6.1](#)

#### References

65, 68 and 69.

**Mandate A.6.6.1:**

Plastic parts weighing more than 25 grams shall be material coded in accordance with ISO 11469 and ISO 1043-1, -2, -3, -4.

Exempted are *printed wiring board laminates*.

**The following information shall be submitted to an approved verifier:**

A written guarantee that the above mandate is fulfilled. The guarantee shall be signed by the responsible person at the applicant company.

**The following information shall be submitted with the application to TCO Development:**

A copy of a verification report from a verifier approved by TCO Development.

We hereby guarantee that the above mandate is fulfilled.

.....  
Product brand name

.....  
Model name(s)

.....  
Signature

.....  
Name and title in block capitals

.....  
Date

.....  
Company

### **A.6.6.2 Take back system**

#### **Background**

The amount of electronic waste in the world today is enormous and a growing environmental problem. It is important that manufacturers provide mechanisms to take back their equipment at end-of-life under the principle of individual producer responsibility wherein each manufacturer must be financially responsible for managing its own branded products at end-of-life. Currently much electronic waste is being exported to developing countries where it is managed unsustainably and disproportionately burdens those regions with this global environmental problem. The Basel Convention and its decisions govern the export of many types of electronic waste, however it is not properly implemented in all countries. With this mandate TCO Development aims to influence the expansion of better electronic waste management practices to more countries.

#### **Definition**

*Brand owner:* The company or organization owning or controlling the Brand Name.

*Brand Name:* The name or sign, including but not limited to a trademark or company name, used to identify, amongst users and customers, the manufacturer or seller of a product.

*Take back system* is a system that makes sure that the customer can return used products to be recycled. The system can be with or without a fee.

*Environmentally acceptable recycling methods* are:

- Product and component reuse
- Material recycling with secured handling of hazardous chemicals and heavy metals
- Pollution-controlled energy recovery of parts of the product

#### **Applicability**

All FPDs.

#### **Clarification**

[B.6.6.2](#)

#### **References**

70.



### A.6.6.3 Preparation for recycling of product packaging material

**Background**

Packaging constitutes a well-known environmental problem and is regulated in many countries worldwide. Packaging material has a short lifetime and generates large volumes of waste.

There are three main areas of concern; hazardous substance content, use of resources and transport volume.

**Applicability**

All packaging material.

**Mandate A.6.6.3:**

**Non-reusable packaging components weighing more than 25 grams shall be possible to separate into single material types without the use of tools.**

**Exempted is reusable packaging.**

**The following information shall be submitted to an approved verifier:**

**A written guarantee that the mandate above is fulfilled. The guarantee shall be signed by the responsible person at the *applicant* company.**

**The following information shall be submitted with the application to TCO Development:**

**A copy of a verification report from a verifier approved by TCO Development.**

We hereby guarantee that the above mandate is fulfilled.

Product brand name	Model name(s)
Signature	Name and title in block capitals
Date	Company



## DECLARATION FORM FOR TCO CERTIFIED DISPLAYS 7.0 ENVIRONMENTAL REQUIREMENTS

### *Applicant company*

*By signing this Declaration Form the Company confirm that the Company has read and accepts to be bound by the below listed environmental requirements as stated in this criteria document. The signature of this form is to be considered equal to a signature under each of the below listed individual mandates in this criteria document. The text in this form is compressed to save space so please make sure to read the full explanation under each mandate. Check the boxes for the documents that have been attached to this form.*

- A.1.1 TCO Certified Document
- A.6.1 Product description
  - Completed product declaration form
  - Copy of the marking label for FPD and PSU
- A.6.2.1 Environmental management system certification
  - Addresses of manufacturing plants
  - Valid EMAS certificate or ISO 14001 certificate
- A.6.4.1 Cadmium, mercury, lead and hexavalent chromium
- A.6.4.2 Halogenated substances
- A.6.4.3 Non-halogenated substances
- A.6.4.4 Halogenated plastics
- A.6.4.5 Phthalates
- A.6.4.6 Hazardous substances in product packaging
- A.6.6.1 Material coding of plastics
- A.6.6.3 Preparation for recycling of product packaging material

We hereby guarantee that the above mandate is fulfilled.

Product brand name	Model name(s)
Signature	Name and title in block capitals
Date	Company

## DECLARATION FORM FOR TCO CERTIFIED DISPLAYS 7.0 ENVIRONMENTAL REQUIREMENTS

### *Brand owner*

*By signing this Declaration Form the Company confirm that the Company has read and accepts to be bound by the below listed environmental requirements as stated in this criteria document. The signature of this form is to be considered equal to a signature under each of the below listed individual mandates in this criteria document. The text in this form is compressed to save space so please make sure to read the full explanation under each mandate. Check the boxes for the documents that have been attached to this form.*

A.6.5.1 Lifetime extension

A.6.6.2 Take back system

1. Product only sold on markets with WEEE legislation or similar

2. World-wide product take back\*

3. One additional market lacking WEEE legislation where product take back is offered\*

\* Short description or reference of the above

We hereby guarantee that the above mandate is fulfilled.

.....  
Product brand name

.....  
Model name(s) or "All products"

.....  
Signature

.....  
Name and title in block capitals

.....  
Date (Declaration valid 1 year from date)

.....  
Company

## A.7 Socially responsible manufacturing

Shorter product cycles and growing demand for new technologies put increasing pressure on industry and its complex supply chain to deliver new devices faster and at a low cost. The result is often inadequate working conditions at manufacturing facilities, long working hours, low wages and a lack of health and safety measures.

TCO Development aims for greater brand engagement throughout their supply chains by setting criteria and verification routines that create strict social policies toward suppliers, as well as factory audit structures and an open dialog within the IT industry.

### Life Cycle Phase



## A.7.1 Supply chain responsibility

### Background

It is TCO Developments opinion that codes of conducts and factory audits are currently the tools that are most practical to help the majority of brands to work with socially responsible manufacturing in a structured way. It is also TCO Developments opinion that these tools are improving the situation incrementally as long as they are used in the correct and committed way by the brand.

The contribution of TCO Certified is:

- TCO Certified defines a minimum level of the Brand owner's code of conduct.
- TCO Certified is a control system to ensure that the brand takes the responsibility and work in a structured way in accordance with their code of conduct.
- TCO Certified creates an incentive for Brand owners to work proactively.

### Definitions

*Brand owner:* The company or organization owning or controlling the Brand Name.

*First tier manufacturing facility:* Manufacturing plant where the final assembly of the TCO certified product is taking place.

*Corrective action plan:* A list of actions and an associated timetable detailing the remedial process to address a specific problem

### Applicability

The Brand owner.

### Clarification

[B.7.1](#)

### References

58 and 59

**Mandate A.7.1:**

By signing this mandate the Brand owner agrees to the (1. Commitment) and agrees to conduct the (2. Structured work). Additionally TCO Development requires that the Brand owner show (3. Proof) of the commitment and the structured work by allowing random inspections, by sharing audit reports and corrective action plans and by providing other documented proof described below.

**1. Commitment:**

The *Brand owner* shall have a code of conduct that is considered consistent with the following in the manufacturing of TCO Certified products:

- ILO eight core conventions: 29, 87\*, 98\*, 100, 105, 111, 138 and 182.
- UN Convention on the Rights of the Child, Article 32.
- Relevant local and national Health & Safety and Labour laws effective in the country of manufacture.

\*In situations with legal restrictions on the right to freedom of association and collective bargaining, non-management workers must be permitted to freely elect their own worker representative(s) (ILO Convention 135 and Recommendation 143).

**2. Structured work:**

- The Brand owner shall ensure that routines are in place to implement and monitor their code of conduct in the manufacturing of TCO Certified products.
- In the final assembly factories the Brand owner shall ensure the implementation of their code of conduct through factory audits.
- In the final assembly factories and in the rest of the supply chain the Brand owner shall ensure that a corrective action plan is developed and fulfilled within reasonable time for all violations against their code of conduct that the Brand owner is made aware of.

**3. Proof:**

- TCO Development may conduct/commission random factory inspections (spot-checks) at any final assembly factory manufacturing TCO Certified products for the Brand owner and may require full audit reports during the certification period in order to assess social commitment and advancement.
- TCO Development may also require seeing corrective action plans and auditing reports from factories further down the supply chain to ensure that corrective actions have been successfully implemented.
- TCO Development additionally requires the documentation below to be verified by a third party approved verifier.

**Submit the following to an approved verifier:**

The Brand owner shall submit all of the following as proof of their commitment and structured work:

1. The Brand owner shall submit their code of conduct, which must be considered consistent with the criteria under 1. Commitment.
2. The Brand owner shall annually submit proof that management and workers at all final assembly factories manufacturing TCO Certified products have been informed about the Brand owner's code of conduct.
3. The Brand owner shall annually submit a list of all final assembly factories manufacturing TCO Certified products. This list shall include the dates of the most recent social audits covering the Brand owner's code of conduct and the dates of planned audits for each factory. The list shall show that all factories have or will be audited at least once over a 3-year period.
4. The Brand owner shall annually submit for review one third party audit report from one final assembly factory manufacturing TCO Certified products to demonstrate that the audits are conducted in a serious manner. The audit report shall at least cover the criteria in A.7.1 of TCO Certified and be of equal quality as an EICC audit. It shall not be more than 12 months old.
5. The Brand owner shall submit a corrective action plan for all nonconformities against A.7.1 of TCO Certified found in the submitted third party factory audit.

If this is the first time the *Brand owner* certifies products to this generation of the criteria and time is needed to develop the proof above then the Brand owner can seek a 12 months grace period on the first application. TCO Development reserves the right to deny grace period if the Brand owner is considered a high risk for not meeting the 12 month due date. When seeking grace period an agreement must be completed/signed by the senior management representative at the *Brand owner* company.

**The following information shall be submitted to an approved verifier:**

- A written guarantee that the mandate above is fulfilled. The guarantee shall be signed by the responsible person at the *brand owner* company.

**Submit the following together with the application to TCO Development:**

- A copy of a verification report from a verifier approved by TCO Development.

We hereby guarantee our commitment to fulfilling the mandate.

..... Product brand name	..... Model name(s) or "All products"
..... Signature	..... Name and title in block capitals
..... Date (Declaration valid 1 year from date)	..... Brand Owner Company

## A.7.2 Senior Management Representative

### **Background**

It is beneficial to all parties that an open and transparent dialogue between TCO Development and the Brand owner exists for the monitoring of compliance with the criteria or when issues concerning working conditions at manufacturing facilities require clarification. A contact person responsible for the organization's efforts to enforce the social responsible manufacturing criteria needs to be consistently available for dialogue with TCO Development throughout the validity of the certificate.

### **Applicability**

The Brand owner.

### **Clarification**

[B.7.2](#)

**Mandate A.7.2:**

The Brand owner shall have an appointed Senior Management Representative (SMR) who, irrespective of other responsibilities, has the authority to ensure that the social criteria in the manufacturing of TCO Certified products are met and who reports directly to top management.

- The contact details of the SMR shall be submitted and the SMR shall be available for dialogue in English with TCO Development throughout the validity of all the Brand owners' certificates.
- To ensure that the SMR has the necessary authority and is working in a structured and proactive way implementing the code of conduct, a review of the SMR shall be done every year according to B.7.2.2.

**Submit the following to an approved verifier:**

1. Name, Title, Telephone Number and Email Address of the SMR.
2. A written guarantee that the above mandate is fulfilled. The guarantee shall be signed by the SMR at the Brand owner company.

**Submit the following together with the application to TCO Development:**

A copy of a verification report from a verifier approved by TCO Development.

Complete the table using block lettering

Name	
Business title	
Telephone	
E-mail	

We hereby guarantee that the above mandate is fulfilled.

.....  
Product brand name

.....  
Model name(s) or "All products"

.....  
Signature

.....  
Name and title in block capitals

.....  
Date (Declaration valid 1 year from date)

.....  
Brand Owner Company



### **A.7.3 Conflict minerals**

#### **Background**

The exploitation and trade of the natural resources, Tantalum, Tin, Tungsten and Gold (3T+G) from conflict-affected areas is commonly regarded as a major source of conflict financing. TCO Development supports the underlying goal of the EU conflict minerals measures and those contained in the Dodd Frank Act 1502, but believe it is also vital to support in-region responsible sourcing programs in order to help suppliers meet these Due Diligence requirements, maintain trade and develop mining that directly benefits the people whose livelihoods depend on a legitimate trade. TCO Development now requires all Brand owners who use TCO Certified to address the issue of conflict minerals in their certified products in a progressive and proactive way.

#### **Definitions**

*Conflict minerals*: Tantalum, Tin, Tungsten and Gold = 3T+G

*DRC*: Democratic Republic of the Congo

#### **Applicability**

The Brand owner.

#### **Clarification**

B.7.3

#### **Reference**

7

**Mandate A.7.3:**

The Brand owner shall have a public conflict minerals policy and also indicate all the initiatives they are using/funding. It is TCO Developments opinion that the OECD Due Diligence Guidance for Responsible Supply Chain of Conflict-Affected or High-risk Areas is the most ambitious approach in the list.

At least one of the following options shall be marked:

- A Due Diligence process based on the OECD Due Diligence Guidance for Responsible Supply Chains of Minerals from Conflict-Affected or High-risk Areas
- iTSCi (International Tin Research Institute (ITRI) Tin Supply Chain Initiative).
- CFTI (Conflict-free Tin Initiative).
- PPA (The Public-Private Alliance for Responsible Minerals Trade).
- Other relevant DRC in-region initiative:.....
- CFSI (EICC/GeSi Conflict-Free Sourcing Initiative).

**Submit the following to an approved verifier:**

- 1 The completed TCO Certified Conflict Minerals Questionnaire and supporting documents
- 2 A written guarantee that the above mandate is fulfilled. The guarantee shall be signed by the responsible person at the Brand owner company

**Submit the following together with the application to TCO Development:**

A copy of a verification report from a verifier approved by TCO Development.

We hereby guarantee that the above mandate is fulfilled.

.....	.....
Product brand name	Model name(s) or "All products"
.....	.....
Signature	Name and title in block capitals
.....	.....
Date (Declaration valid 1 year from date)	Brand Owner Company

## R References

International standard organisations referred to and their home pages.

- ASTM, American Society for Testing and Materials, <http://www.astm.org/>
- CIE, Commission Internationale de l'Eclairage, International Commission on Illumination, [www.cie.co.at/cie/](http://www.cie.co.at/cie/)
- DIN, Deutsches Institut für Normung e. V., [www2.din.de](http://www2.din.de)
- EBU, European Broadcasting Union, [http://www.ebu.ch/tech\\_info.html](http://www.ebu.ch/tech_info.html)
- IEC, International Electrotechnical Commission, [www.iec.ch](http://www.iec.ch)
- ISO, International Organization for Standardization, <http://www.iso.org/>
- ITU, International Telecommunication Union [www.itu.int/home/index.html](http://www.itu.int/home/index.html)
- SMPTE, Society of Motion Picture Television Engineers, [www.smpte.org](http://www.smpte.org)
- VESA, Video Electronics Standards Association, [www.vesa.org](http://www.vesa.org)

1. CIE Publication 69 (1987), Methods of characterizing illuminance meters and luminance meters: performance characteristics and specifications.
2. Flat Panel Display Measurements Standard, (FPDM), Version 2.0, VESA - Video Electronics Standards Association Display Metrology Committee. June 1, 2001, CA 95035, Milpitas.
3. <http://www.w3.org/Graphics/Color/sRGB.html>
4. SMPTE RP 145-1994: SMPTE C Colour Monitor Colorimetry
5. GovTrack.us. "H.R. 4040--110th Congress (2007): Consumer Product Safety Improvement Act of 2008, GovTrack.us (database of federal legislation) . Retrieved 14 August 2009.
6. ECHA Website - Proposal for identification of Substances of Very High Concern
7. <http://www.oecd.org/corporate/mne/mining.htm>
8. CIE Publication 15.2 (1986), Colorimetry, p. 11, p.27-28 and p. 53-54, table 1.3).
9. IEC 61966-2-1 (1999-10) Multimedia systems and equipment - Colour measurement and management - Part 2-1: Colour management - Default RGB colour space – sRGB.
10. ITU-R Recommendation BT.470-6: Conventional television systems.
11. ITU-R Recommendation BT.709-5: Parameter values for the HDTV standards for production and international programme exchange
12. E.B.U. Standard for chromaticity tolerances for studio monitors Tech. 3213-E August 1975.
13. SMPTE 170M-1999 Television - Composite Analogue Video Signal - NTSC for Studio Applications.
14. Hunt, R.W.G. Measuring colour. 3rd edition (1998), Kingsley-Upon-Thames: Fountain Press.
15. ISO TC130 WD 12646 p. 5 Section 4.7 Chromaticity and luminance of the white and black points and tracking.
16. ISO 3664:1999, Viewing conditions for graphic technology and photography, p. 9 Uniformity of screen luminance.

17. ISO 3664:1999, Viewing conditions for graphic technology and photography, p. 5, 4.2.4 Surround and backing for reflection viewing, Note 1 p. 8.
18. ISO 3664:1999. Viewing conditions for graphic technology and photography, p. 10 Monitor luminance.
19. Barten, P.G.J., (1999) Contrast sensitivity of the human eye and its effects on image quality, SPIE Optical Engineering Press
20. Barten, P.G.J., (1999) Contrast sensitivity of the human eye and its effects on image quality, SPIE Optical Engineering Press p. 105 - 106. (ISBN 0-8194-3496-5)
21. Barten, P.G.J., (1999) Contrast sensitivity of the human eye and its effects on image quality, SPIE Optical Engineering Press p. 179.
22. Barten, P.G.J., (1999) Contrast sensitivity of the human eye and its effects on image quality, SPIE Optical Engineering Press p. 179 - 181.
23. Kokoschka S. (1986). Visibility aspects of VDUs in terms of contrast and luminance. Behaviour and information technology. vol.5, No. 4, pp 309-333.
24. Schenkman, B., and Kjelldahl, L. (1999). Preferred colour temperature on a colour screen. Displays, 20, 73 - 81.
25. Roberts, A., Eng, B., (1995) "A method for the calculation of tolerances for display primary chromaticity coordinates" Research and development Department, Technical Resources, The British Broadcasting Corporation.
26. [www.srgb.com](http://www.srgb.com)
27. Wyszecki, G., Stiles, W.S., (1982) Colour Science: Concepts and methods, quantitative data and formula, Second Edition, John Wiley & Sons, Inc. Chapter 7, Visual thresholds, pp 567-569.
28. Wyszecki, G., Stiles, W.S., (1982) Colour Science: Concepts and methods, quantitative data and formula, Second Edition, John Wiley & Sons, Inc. Chapter 7, Visual thresholds, pp 574-575.
29. Le Grand, Y. (1957). Light, colour and vision. Chapman and Hall, pp 278-279.
30. Le Grand, Y. (1957). Light, colour and vision. Chapman and Hall.
31. Le Grand, Y. (1957). Light, colour and vision. Chapman and Hall, p. 119
32. Le Grand, Y. (1957). Light, colour and vision. Chapman and Hall, Chapter 11, Luminance difference thresholds, p. 261.
33. Le Grand, Y. (1957). Light, colour and vision. Chapman and Hall, Chapter 11, Luminance difference thresholds.
34. Le Grand, Y. (1957). Light, colour and vision. Chapman and Hall, Chapter 12, Colour difference thresholds p. 279.
35. Fairchild M. D. (1995), "Considering the surround in device-independent colour imaging". [www.cis.rit.edu/people/faculty/fairchild/PDFs/Bart.pdf](http://www.cis.rit.edu/people/faculty/fairchild/PDFs/Bart.pdf)
36. ISO 13406-2 Ergonomic requirements for work with visual displays based on flat panels - Part 2: Ergonomic requirements for flat panel displays. International Organisation of Standardisation.
37. -
38. ISO 9241-8 Ergonomic requirements for office work with visual display terminals (VDTs) - Part 8: Requirements for displayed colours. International Organisation of Standardisation.
39. AFS, the Swedish Environment Authority's Provisions and General Recommendations 1998:5

40. DIN 33402
41. EC Directive 90/270/EEC EU Directive 90/270/EEC Minimum safety and health requirements for work with display screen equipment.
42. ISO 11226 Ergonomics -- Evaluation of static working postures
43. ISO 13406-2 Ergonomic requirements for work with visual displays based on flat panels - Part 2: Ergonomic requirements for flat panel displays. International Organisation of Standardisation.
44. ISO 9241-3 Ergonomic requirements for office work with visual display terminals (VDTs) -- Part 3: Visual display requirements. International Organisation of Standardisation, 1992
45. ISO 9241-5 Ergonomic requirements for office work with visual display terminals (VDTs) - Part 5: Workstation layout and postural requirements. International Organisation of Standardisation.
46. Nymans, Berns, Gelin 1995, research report "Do AM-LCD monitors offer better ergonomic solutions than CRTs?"
47. Statshälsan 1990, User recommendations from the Swedish Foundation of Occupational Health for State Employees, report "Man, Monitor and Work Environment"
48. UK Department of Trade and Industry, Consumer Safety Unit, Adult data DTI/Pub 45/3k/01/00/NP
49. VESA Flat Panel Monitor, Physical Mounting Interface Standard (FPMPMI), version 2.0, Revision 3, March 1, or VESA Flat Display Mounting Interface Standard, (FDMI) Version 1 October 28, 2002 which replaces and supersedes FPMPMI.
50. EN 60950 (IEC 60950). Safety of information technology equipment including business equipment.
51. Bilissi, E., Jacobson, R. E., and Attridge, G. G (2008): "Just noticeable gamma difference and acceptability of sRGB image display on a CRT monitor, Imaging Technology Research Group, University of Westminster, Harrow, UK, The Imaging Scient Journal Vol 56, 189-200.
52. Shimodaira, Y. et al., (1995), "Acceptable limits of gamma for a TFT-liquid crystal display on subjective evaluation of picture quality" Consumer Electronics, IEEE Transactions Volume 41, Issue 3, 550-554.
53. EN 60950-1 (IEC 60950-1). Safety of information technology equipment including business equipment.
54. EMAS EU regulation no 761/2001 concerning the voluntary participation of industrial companies in the Union's environmental control and review structure.
55. ISO 14001 Environmental management systems - Specification with guidance for use
56. -
57. -
58. Electronic Industry Citizenship Coalition (EICC), <http://www.eicc.info>
59. SA8000, <http://www.sa-intl.org>
60. ENERGY STAR® Program Requirements for Displays
61. International Efficiency Marking Protocol for External Power Supplies
62. EU Directive 2006/66/EC on batteries and accumulators containing certain dangerous substances

63. EU Directive 2011/65/EU on the restriction of the use of certain hazardous substances in electrical and electronic equipment
64. Regulation concerning Registration, Evaluation, Authorisation and Restriction of Chemicals (REACH), EC 1907/2006
65. EU Directive 67/548/EEC on the approximation of laws, regulations and administrative provisions relating to the classification, packaging and labelling of dangerous substances
66. EU Directive EC 1272/2008 on classification, labelling and packaging of substances and mixtures
67. The EU Green Paper “Environmental questions concerning PVC” KOM (2000) 469
68. ISO 11469:2000 Plastics - Generic identification and marking of plastics products
69. ISO 1043-1, -2, -3, -4 Plastics - Symbols and abbreviated terms
70. EU Directive 2002/96/EC on waste electrical and electronic equipment (WEEE)
71. Directive 94/62/EC on packaging and packaging waste.
72. Poynton, C. (2003), Digital video and HDTV Algorithms and interfaces, Morgan Kaufmann Publishers, An Imprint of Elsevier Science. Chapter 23 Gamma sRGB transfer function page 267 to 269. ISDN 1-55860-792-7
73. Humanscale 1/2/3, Niels Diffrient, Alvin R Tilley, Joan C Bardagjy. 1974
74. MOD, Defence standard 00-250. Human Factors for Designers of systems Part 3 (section 13 – The workplace)
75. [http://www.umweltbundesamt.at/fileadmin/site/umweltthemen/abfall/ROHS/fin\\_alresults/Annex6\\_RoHS\\_AnnexII\\_Dossier\\_DEHP.pdf](http://www.umweltbundesamt.at/fileadmin/site/umweltthemen/abfall/ROHS/fin_alresults/Annex6_RoHS_AnnexII_Dossier_DEHP.pdf) [DEHP]
76. [http://www.umweltbundesamt.at/fileadmin/site/umweltthemen/abfall/ROHS/fin\\_alresults/Annex7\\_RoHS\\_AnnexI\\_I\\_Dossier\\_BBP.pdf](http://www.umweltbundesamt.at/fileadmin/site/umweltthemen/abfall/ROHS/fin_alresults/Annex7_RoHS_AnnexI_I_Dossier_BBP.pdf) [BBP];
77. [http://www.umweltbundesamt.at/fileadmin/site/umweltthemen/abfall/ROHS/fin\\_alresults/Annex8\\_RoHS\\_AnnexI\\_I\\_Dossier\\_DBP.pdf](http://www.umweltbundesamt.at/fileadmin/site/umweltthemen/abfall/ROHS/fin_alresults/Annex8_RoHS_AnnexI_I_Dossier_DBP.pdf) [DBP].
78. [http://rohs.exemptions.oeko.info/fileadmin/user\\_upload/reports/20140520\\_DIB\\_P\\_AnnexII\\_Dossier\\_final.pdf](http://rohs.exemptions.oeko.info/fileadmin/user_upload/reports/20140520_DIB_P_AnnexII_Dossier_final.pdf) [DIBP].
79. <http://www.step-initiative.org/>

## **B Test methods and clarifications**

The following definitions, test conditions, requested specifications from clients, and other information apply to test methods described in this document.

Test results are valid only for the presentation form(s) and configuration(s) tested.

### **B.0 General test conditions**

#### **B.0.1 Definition of a test object**

- Test objects covered by this document are flat panel visual display units, henceforth called FPDs (Flat Panel Displays) with fixed positions of the pixels.
- A test object is defined as the FPD or the FPD plus necessary equipment in order to generate a test image. Any accessory, such as a graphic card, a video generator or a character generator that can affect the test result can be considered part of the test object if the client so specifies and it is delivered as a part of the product to the end user.
- A test object with all necessary information for its operation shall be delivered to the test facility in test ready condition including any required accessories. All necessary information about how to operate and adjust the test object shall be provided.
- The client shall inform the test facility if any image enhancement software or hardware is used for the FPD and which input ports that have image enhancement.
- The performance of the test object shall in all aspects be fully in accordance with the performance of the final product.

#### **B.0.2 Required test object information**

The client shall specify:

- Name(s), type designation(s) and manufacturer for all different exchangeable parts of the test object.
- If a particular graphic card or video generator shall be used for testing (see B.0.3).
- Display resolution of the FPD and the vertical and horizontal frequencies for testing.



### **B.0.3 Graphic card (Video adapter)**

- The client shall specify if a particular graphic card shall be used for testing. In this case the graphic card shall be representative of the common use of the FPD, for example included in the motherboard of associated equipment. Non-standard graphic cards shall not be accepted for testing, unless they are for a special purpose relevant for the product and sold together with it. If the client does not specify a graphic card, a high quality standard graphic card from the test facility shall be used. This shall be reported in the test report and the client shall be informed. The graphic card shall be easily commercially available or supplied with the display and be of recent model, in order to give the tested combination a more general validity and to give any user of the FPD the possibility of purchasing the same graphic card as used in the testing. The most recent versions of graphic cards and drivers are recommended. The graphics board shall offer a typical output voltage on RGB of  $0.7\text{ V} \pm 10\%$ .
- A character generator or video generator shall only be used to operate the FPD if it is not possible to use a standard graphic card. This is because a character generator is not representative of the usual way an FPD is run.
- The graphic card used for testing shall not be used for more than the test object during the test, if not stated by the client.
- The computer or similar devices used to run the test object in the test shall not use any unnecessary software or hardware that could influence the test.
- All settings in the operating systems shall be the default ones as delivered to the end user or the default as it appears directly after the installation of the operating system.

### **B.0.4 Conditions for the equipment under test**

- The FPD being tested shall be physically prepared for testing and shall be warmed up for at least 30 min or until it is stabilised. The test engineer shall not need to wait for more than 1 hour for the display to be considered stable. In this instance the engineer may cancel the test and demand a replacement sample.
- The FPD screen surface shall be clean when tested.
- The FPD shall be tested under nominal conditions of input voltage, current, etc. If sold on different markets, one setup shall be chosen by the manufacturer and shall represent the conditions of the country where it will be sold the most.
- When possible testing shall be done with the digital signal input. In the case of several digital inputs the one with the lowest bandwidth that can still support the native resolution shall be used. The same signal input shall be used for testing of all parameters. The signal input used shall be specified in the test report.
- If the product relies on network connection to function a network connection must be established. Otherwise the FPD shall be tested without load on any peripheral interface such as USB, firewire or network hub, memory card slot, loudspeakers or similar unless otherwise stated by the test procedure.



## **B.0.5 FPD alignment for testing**

The FPD screen front shall be aligned vertically with the possibility to rotate the screen  $\pm 30^\circ$  around a vertical axis through the centre-point of the screen front. It shall also be possible to rotate the screen forwards and backwards  $\pm 15^\circ$  around a horizontal axis through the same centre-point.

## **B.0.6 Instruments used for testing**

All instruments used for testing of a FPD shall be of good quality and validated by a recent test certificate from a certified testing facility. Any necessary instrument calibration shall be done before the tests are performed. Calibrations shall be traceable to national standards.

## **B.0.7 Settings of the FPD**

- Pivot screens shall only be measured in the usual landscape mode.
- The FPD resolution shall be set to the native resolution
- The FPD shall be put in its factory default mode. The CCT of the default mode shall be used.
- All tests shall be performed with the FPD in the factory default mode if not stated otherwise in the test methods.
- Integrated automatic sensors and any eco-mode functions enabled by default on the display shall be disabled by the test engineer for all the tests, as long as by doing so the default CCT setting does not change.
- Testing may be done with a preset instead of the default mode if the user is informed in the user manual which preset is used for TCO Certified compliance. In this case this preset shall be treated as the default mode in the criteria document and noted in the test report.
- All measurements shall be taken with no adjustments made between the measurements, if not specified otherwise in the test method.
- An external control unit that is not a standard part of the FPD is not allowed.
- The colour depth of the source signal shall be 24 bits (8 bits per colour channel) or more.
- In Windows/Display Properties/Settings/Advanced the Windows “Small fonts” option shall be used.
- In Windows/Display Properties/Appearance the “Windows standard” colour scheme option shall be used.

## **B.0.8 Test image/test character**

- All test images can be found on TCO Development’s home page, [www.tcodevelopment.com](http://www.tcodevelopment.com).
- The default testing 12 point Arial font and 100% “zoom/magnification” shall be used. The latest version of MS Windows operating system is the default user

interface, if not otherwise stated. For Macintosh displays, Mac OS can be used during the testing.

- The default testing polarity is positive polarity (black characters on a white background).
- Another possibility is to use a testing program that shall consist of software commonly used in office and home computer work. The word processor should be able to produce the text and graphics required for the test procedures.
- All parts of the tests for a test object shall be conducted using the same font, character size, correlated colour temperature, resolution, operating system and other settings of the FPD controls etc., unless otherwise stated in the test procedure.

### B.0.9 Test Image and Test Luminance setting

The test image in Figure B.0.9.1, referred to as the TCO Certified default test image, has an 80 % image loading. The test image shall fill the whole usable screen that represents the “full screen mode”. This image shall be used for testing unless otherwise specified in the test procedure.

If the measured display is not affected by image loading it is permitted to use alternative images (described in *procedure* below) rather than the default test image for measurement of Black level (A.2.2.3) and RGB settings (A.2.4.3). The benefit is to minimize the contribution of stray-light for some measurement equipment. In the event that this method is chosen, pay extra attention to displays with dynamic backlight as they may be affected by the different image loading.

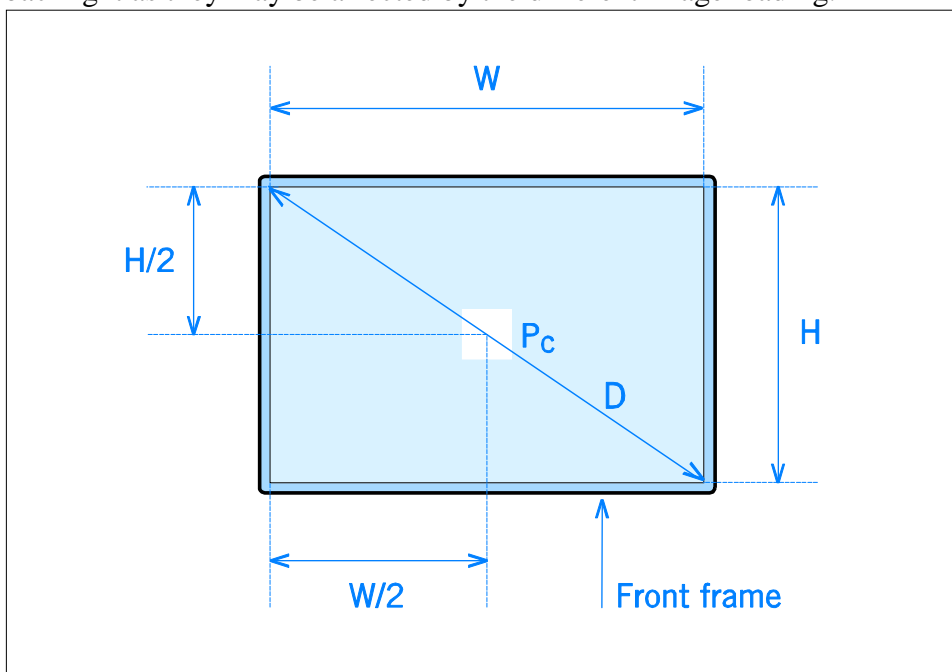

**Figure B.0.9.1. The TCO Certified default test image.**

Procedure:

- The background colour shall be set to RGB 204, 204, 204 (i.e. equal to 80 % image loading).
- An active white square at the centre of the screen shall be  $4^\circ \times 4^\circ$  in size and have an RGB setting of 255, 255, 255. The  $4^\circ \times 4^\circ$  corresponds to an area of about 34.9 mm  $\times$  34.9 mm at a measuring distance of 500 mm or 69.8 mm  $\times$  69.8 mm at 1 meter. For a 15" display measured at 57 cm, the  $4^\circ \times 4^\circ$  corresponds to a square of 40 mm  $\times$  40 mm.
- A permitted alternative to the  $4^\circ \times 4^\circ$  test square when testing Black level and RGB settings is to increase the test square to a size that is equal to 80% of the full screen mode area. The background shall continue to be RGB 204, 204, 204.

**Test Luminance setting:**

- Reset the product to its default mode settings (as intended to be delivered to the end user). If the product has an automatic adjustment this can be activated once. In the default mode the luminance of the FPD shall be  $\geq 150 \text{ cd/m}^2$ . If the luminance is lower, then testing cannot proceed since the product does not comply with TCO certified.

## B.0.10 Test report

The test results are valid only for the presentation form(s) and configuration(s) tested. If other configurations are accepted by the test facility based on the results of the tested ones it shall be clearly specified in the test report that these configurations have not been tested.

The test report shall include the following information:

- Any changes to the test methods.
- The manufacturer, brand name, model type and serial number (if available).
- The panel brand, full panel number, if the screen is pivot stand type and if it has a LED backlight.
- The mode(s) (i.e. horizontal and vertical scan frequency and resolution) used during the test and the aspect ratio.
- The supply voltage and frequency used during the test and whether it is a CLASS I or CLASS III type. If CLASS III the AC external power supply's brand and model number shall also be stated.
- The degree of uncertainty for each given measurement result.
- The setting of contrast, brightness and CCT preset at the reset default setting.
- Photographs of the product showing: Front, rear, open panel, a legible panel marking label and if applicable the external power supply with legible marking label.

## **B.1 General information**

### **B.1.1 Information to end users**

The TCO Certified Document shall accompany the product as provided by TCO Development. No editorial changes without TCO Development's consent are accepted. The Document is available at [www.tcodevelopment.com](http://www.tcodevelopment.com).

If the product that is to be TCO Certified is branded differently from the applicant name, the applicant company signing the guarantee shall be sure that the brand owner agrees with the requirement.

Compliance is through one of the following options:

1. Separate printed document

The TCO Certified Document is placed in the packaging and accompanies the product to the end user

2. In the user manual or a digital file

The TCO Certified Document is placed in the user manual or a digital file and accompanies the product to the end user. The TCO Certified Document shall be printed under a headline for TCO Certified. This headline shall be visible in the table of contents of the user manual or digital file.

The TCO Document must be separated from other text portions of the user manual or digital file so that it is obvious that the TCO Document is not accountable for the content of any other texts.

3. On the brand owner web site.

A direct link to the TCO Certified Document on the brand owner's web page is placed in the user manual or digital file and accompanies the product to the end user. There shall be a headline for TCO Certified in the user manual or digital file. This headline shall be visible in the table of contents. With this headline there shall be a direct link to the TCO Certified document on the brand owner's website. Also accepted are TCO logos or icons that redirect the visitor by a link to the TCO Certified Document

[Back to A.1.1](#)

## **B.2 Visual ergonomics**

### **B.2.0 General test conditions for visual ergonomics**

#### **B.2.0.1 Basic test requirements**

As described in section B.0.  
For all tests, the FPD screen shall be clean.

#### **B.2.0.2 Photometric test facility general requirements**

Photometric measurements shall be performed under darkroom conditions. This means that measurement data shall in no way be affected by direct light from sources or light reflected from interiors, equipment, clothes etc.

The test facility shall have a routine for the control of the stray-light level at the FPD screen (see also B.2.0.6).

#### **B.2.0.3 Power supply and test room climate requirements for testing**

- AC mains voltage\* 230 VAC RMS, tolerance  $\leq 1$  %
- AC mains frequency\* 50 Hz, tolerance  $\leq 2$  %
- Test room temperature  $23 \pm 3$  °C
- Humidity 20-75 % RH (non-condensing)

\* – or other voltage and frequency combination specified by the client.

#### B.2.0.4 Photometric and spectrometric measurements

Several instruments are to be used when carrying out measurements for visual ergonomics. All instruments shall be recently calibrated and carry a calibration certificate from a certified test facility.

The following instrument types are to be used for testing:

- **Luminance meter.** A luminance meter shall have a sufficiently good  $V_{\lambda}$ -sensitivity (Requirements for luminance meters are covered by CIE Publication 69 (1987). Luminance meters of CIE Class L(aboratory) with a combined performance characteristic  $\leq 3\%$  shall be used) and integrate luminance over a finite measuring field during a finite time. The meter shall be equipped with adjustable optics and always be focused on the measured area. The luminance meter must incorporate a sufficiently long time constant of integration in order to ensure averaging of the pulsation of the light emitted by FPDs. The sensitivity shall be independent of the polarization of the measured light (often referred to as  $f_8$  error).

The luminance meter measuring field shall be one degree for all measurements, except for the micro-photometric luminance measurements, see below.

An automated instrument using collimating optics may be used for testing although the measurement area will differ somewhat from the area covered by the luminance meter. When the luminance measurement in this case is done at a shorter distance than  $1.5 \times$  the screen diagonal ( $D$ ) because of instrumental constraints, the facility shall verify that the results are equal to those done at  $1.5 \times D$ .

- **Micro-photometer.** Micro-photometric registration of the luminance distribution of test patterns shall be performed with an array photo detector device capable of resolving structures of  $\leq 0.02$  mm. A scanning device shall not be used because it is sensitive to jitter and other variations that may occur during a scanning.
- **Spectro-radiometer.** An instrument for the measurement of radiant flux as a function of wavelength shall be used. A spectro-radiometer for the measurement of light and colour is normally equipped with a microprocessor that makes it possible to obtain luminance and colour co-ordinates directly from raw measurement data. A spectro-radiometer can replace the luminance meter when suitable. The wavelength resolution shall be  $\leq 4$ nm for accurate colour measurements. The sensitivity shall be independent of the polarization of the measured light (often referred to as  $f_8$  error).

### **B.2.0.5 Measurement distance**

All measurements shall be carried out through a point, simulating the eye position of the operator, at a distance of  $1.5 \times$  “diagonal of the screen” from the centre-point of the FPD screen but no less than 500 mm which could be considered as an absolute minimum viewing distance for comfortably viewing the display. The instrument shall be focused on the presented test image for all measurements.

### **B.2.0.6 Stray light**

Stray light may cause errors which can negatively affect measurement of luminance, contrast and chromaticity coordinates. It is therefore necessary to make an evaluation of stray light influence for the different measurement procedures described in this document.

If it is verified that stray light affects the measurement result it is necessary to take actions to eliminate the source of error. Two possible ways to solve the problem are to equip the luminance meter with a well-designed screening attachment, a frustum or to use a black screening sheet at the FPD surface.

### **B.2.0.7 Overall uncertainty**

The overall uncertainty of the test facility shall be calculated for each measurement procedure in this document and presented in the test report. The uncertainty shall be within the required levels for each criterion. All measurement uncertainties claimed for used instruments shall be referred to traceable calibration reports.

#### **About combining overall uncertainty values during test measurements:**

- Criteria are fulfilled without adding or subtracting the overall measurement uncertainty.
- Report the value shown on the instrument without adding or subtracting the overall measurement uncertainty.
- The overall measurement uncertainty of the test facility shall be printed in the test report together with the reported value.
- For a test facility that has an overall measurement uncertainty higher than the one allowed by TCO Development for a certain criterion, then the test report for that criterion is not valid for certification and the test result will not be accepted by TCO Development.

## B.2.1 Image detail characteristics

### B.2.1.1 Native display resolution requirement

#### B.2.1.1.1 Preparation of the FPD for testing

No specific preparation of the FPD is needed.

#### B.2.1.1.2 Equipment

Calculator and product manual or similar information about the display resolution.

#### B.2.1.1.3 Test method

The maximum resolution and frequencies of the display are found in the manual or similar information from the manufacturer.

#### B.2.1.1.4 Test evaluation

- The viewing distance is defined as  $1.5 \times$  the display diagonal, but no less than 500 mm. This means that the mandate is independent of the display size and viewing distance but dependent on the aspect ratio. Only the aspect ratio needs to be known.

The minimum resolution to fulfil the criteria can be calculated for any aspect ratio in the following way:

#### Minimum amount of pixels in the vertical direction

Half the display height at the viewing distance expressed in degrees is:

- $\arctan(\text{width}/2/\text{viewing distance})$

The whole display height expressed in degrees is:

- $2 \times \arctan(\text{width}/2/\text{viewing distance})$

The requirement is 30 pixels/degree which gives the amount of pixels needed in the vertical direction to:

- $30 \times 2 \times \arctan(\text{width}/2/\text{viewing distance})$

#### Example:

For the format 5:4:3 and viewing distance 1.5 this gives the formula:

- $30 \times 2 \times \arctan(4/2/(1.5 \times 5)) = 896 \text{ pixels}$

The principle is the same in the horizontal direction.

For the most common aspect ratios the mandates are:		
<u>Aspect ratio</u>	<u>Min amount of horizontal pixels</u>	<u>Min amount of vertical pixels</u>
5:4:3	896	679
18.36:16:9	972	557
6.4:5:4	875	706
18.87:16:10	947	601
<b>Note: Aspect ratio is a ratio between [Diagonal : Width : Height]</b>		
For or other aspect ratios the min display resolution shall be calculated.		

#### B.2.1.1.4 Overall uncertainty

Uncertainty is not applicable in this case. Product data information is sufficient.

[Back to A.2.1](#)



## B.2.2 Luminance characteristics

### B.2.2.1 Luminance level

#### B.2.2.1.1 Preparation of the FPD for testing

- All necessary preparations described in B.0 and B.2.0 shall be done.
- The TCO Certified default test image with an 18-step greyscale as shown in Figure B.2.2.1 shall be used for luminance level measurement.

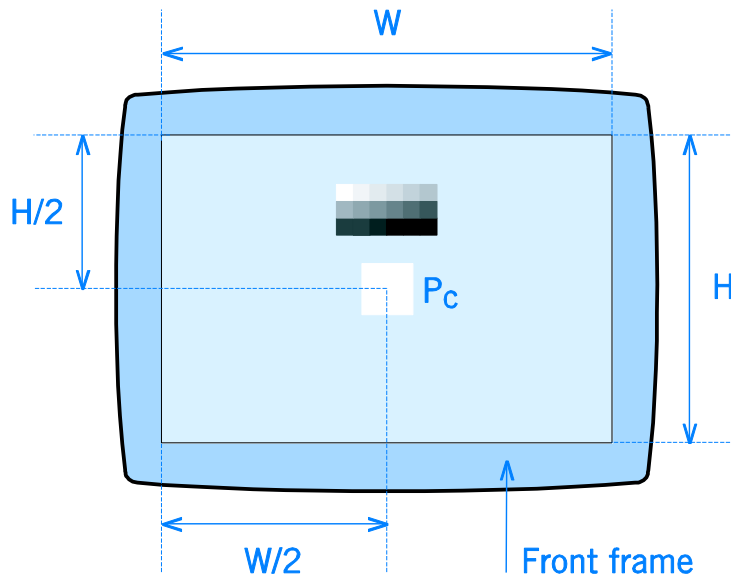

**Figure B.2.2.1. TCO Certified default test image with the 18-step greyscale inserted.**

- The measurement position  $P_C$  shall be at the centre of a  $4^\circ \times 4^\circ$  square without line borders, having an RGB setting of 255, 255, 255, and positioned at the centre of the screen. The background shall be RGB 204, 204, 204.
- Reset the display to its default setting. Check that the luminance is  $\geq 150 \text{ cd/m}^2$ .

The following evaluations shall be carried out orthogonally to the screen surface.

- To achieve the maximum luminance proceed as follows:  
Use the TCO Certified default test image with an 18-step grey scale pattern presented on the screen. From the default setting, adjust the controls on the display to achieve as high luminance as possible with an acceptable image quality. The image quality is considered acceptable if at least 15 of the 18 grey scale steps are visible. At this maximum luminance, test that the display has a luminance  $\geq 200 \text{ cd/m}^2$ .
- Reset the display to its default setting. From the default setting, adjust the controls on the display to achieve as low luminance as possible with an acceptable image quality. The image quality is considered acceptable if at least 15 of the 18 grey scale steps are visible. At this minimum luminance check that the display has a luminance  $\leq 100 \text{ cd/m}^2$ .
- If it difficult to visually determine if 15 of the 18 grey scale steps are visible, then the display shall comply with the gamma curve criteria (A.2.2.5) in the max and min luminance setting.
- After this test is completed the display shall be put back in its default mode by pressing a reset button or similar. After each reset the display has to stabilize before other test measurements are made.

#### **B.2.2.1.2 Equipment**

Luminance meter.

#### **B.2.2.1.3 Test method**

The luminance at the centre of the white test area shall be measured with the luminance meter directed orthogonally to the test area as described in B.2.0.5.

#### **B.2.2.1.4 Test evaluation**

The measured luminance is the required value. The luminance shall be reported with no decimal places.

The measured luminance, Contrast and Brightness settings for all conditions shall be noted in the test report. The preset CCT in default setting shall also be noted.

#### **B.2.2.1.5 Overall uncertainty**

$\leq \pm 10 \%$  in luminance.

See B.2.0.7.

[Back to A.2.2.1](#)

## B.2.2.2 Luminance uniformity

### B.2.2.2.1 Preparation of the FPD for testing

- All necessary preparations described in B.0 and B.2.0 shall be done.
- The entire active area of the screen shall be white and the FPD colour setting shall be RGB 255, 255, 255.

### B.2.2.2.2 Equipment:

Luminance meter.

### B.2.2.2.3 Test method:

The luminance shall be measured orthogonally to the FPD screen plane at 9 points. The 4 corner positions (1, 3, 7 and 9) are measured  $1^\circ$  from the edges of the screen as shown in Figure B.2.2.2.1. The 4 side positions (2, 4, 6 and 8) are measured on the middle of the side  $1^\circ$  from the edge. Finally the centre position (5) is measured. This means that all measurement points have  $1/2^\circ$  marginal to the edges if the measurement area of the instrument is  $1^\circ$ .

The luminance uniformity shall also be evaluated visually by the technician in order to find any dark or bright areas except from the 9 default positions. If a significantly bright or dark area is found these measuring points shall also be measured and used to evaluate the luminance uniformity.

The conditions for luminance measurement in the corner positions and the distribution of other measurement points are illustrated in figure B.2.2.2.1.

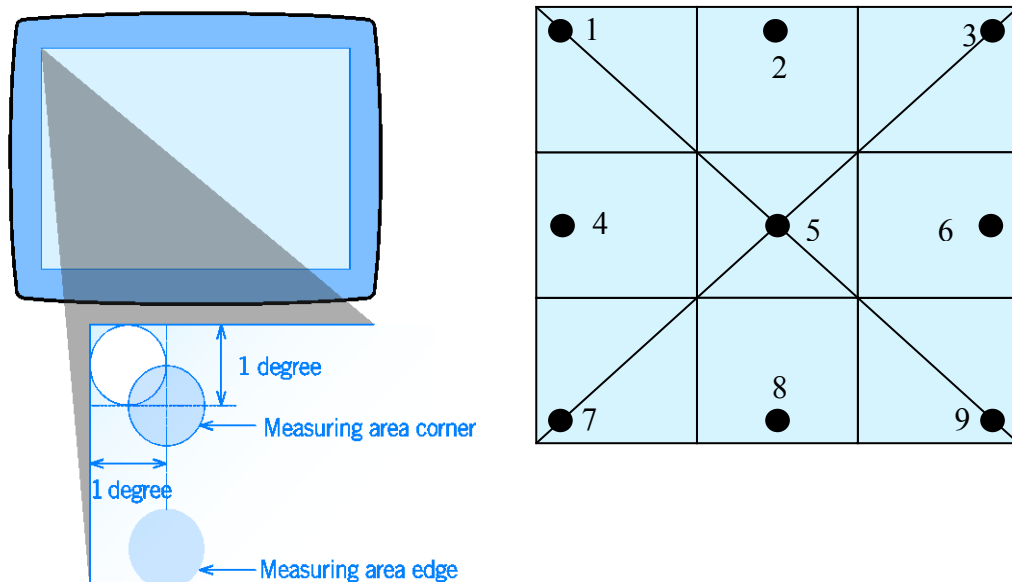

**Figure B.2.2.2.1. Measurement positions for the measurement of luminance and colour uniformity.**

## **B.2.2.2.4 Test evaluation**

The luminance uniformity shall be reported as the ratio between the highest and the lowest measured luminance values.

The result shall be presented to 2 decimal places.

## **B.2.2.2.5 Overall uncertainty**

$\leq \pm 10\%$  in luminance.

$\leq \pm 0.1$  unit in luminance uniformity.

See B.2.0.7.

[Back to A.2.2.2](#)

## B.2.2.3 Black level

### B.2.2.3.1 Preparation of the FPD for testing

- All necessary preparations described in B.0 and B.2.0 shall be done.
- The TCO Certified default test image with an 18-step greyscale as shown in Figure B.2.2.1 or the alternative larger test square image also described in B.0.9 shall be used for luminance level measurement.
- The measurement position  $P_C$  shall be at the centre the a  $4^\circ \times 4^\circ$  test square without line borders, having an RGB setting of 0, 0, 0, and positioned at the centre of the screen. Alternatively for this measurement a test square that is 80% of the full screen mode may be used.
- The black level shall be tested at maximum luminance. This is considered to be  $\geq 200 \text{ cd/m}^2$ .
- To achieve the maximum luminance proceed as follows:  
Use the TCO Certified default test image with an 18-step grey scale pattern presented on the screen. From the default setting, adjust the controls on the display to achieve as high luminance as possible with an acceptable image quality. The image quality is considered acceptable if at least 15 of the 18 grey scale steps are visible. This maximum luminance shall be  $\geq 200 \text{ cd/m}^2$ .
- If it difficult to visually determine if 15 of the 18 grey scale steps are visible, then the display shall comply with the gamma curve criteria (A.2.2.5) in the max luminance setting.
- Change the colour of the white square in the test image to black (RGB: 0,0,0) and measure the luminance of the black square check that it is  $\leq 2 \text{ cd/m}^2$ .

### B.2.2.3.2 Equipment

Luminance meter.

### B.2.2.3.3 Test method

The luminance at the centre of the black test area shall be measured with the luminance meter directed orthogonally to the test area as described in B.2.0.5.

### B.2.2.3.4 Test evaluation

The measured luminance is the required value. The luminance shall be reported to one decimal place.

### B.2.2.3.5 Overall uncertainty

$\leq \pm 10 \%$  in luminance.

See B.2.0.7.

[Back to A.2.2.3](#)

## B.2.2.4 Luminance uniformity – angular dependence

### B.2.2.4.1 Preparation for the FPD testing

- All necessary preparations described in B.0 and B.2.0 shall be done.
- Luminance values shall be measured at five different positions on the screen as shown in Figure B.2.2.4.1. Each measurement position shall consist of white RGB 255, 255, 255 squares sized  $4^\circ \times 4^\circ$  without line borders.
- The background shall be RGB 204, 204, 204.
- The luminance meter shall be positioned and directed orthogonally to the screen centre-point as described in B.2.0.5.

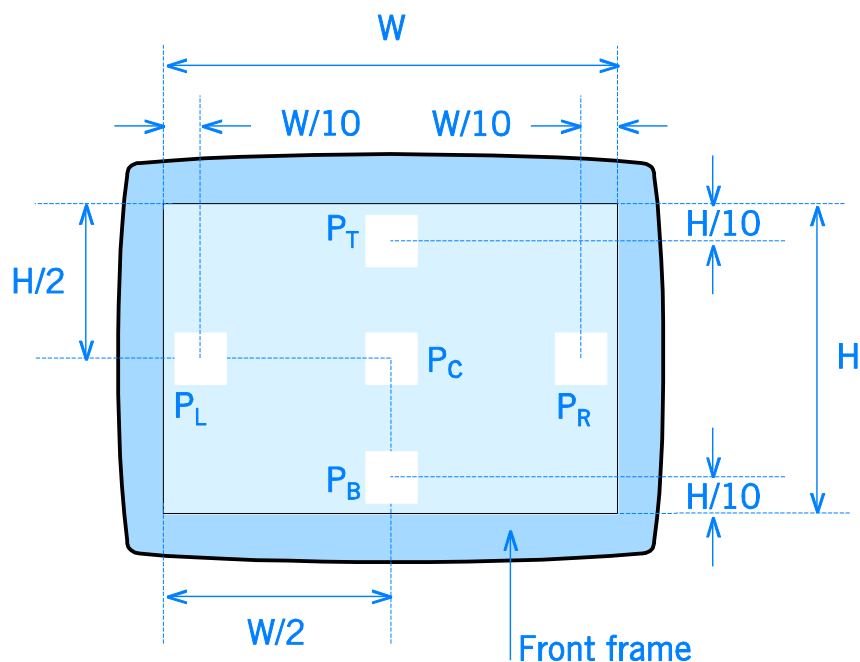

Figure B.2.2.4.1. Measurement positions for angular dependent luminance uniformity.

### B.2.2.4.2 Equipment

Luminance meter.

### B.2.2.4.3 Test method

1. The luminance meter shall always be directed towards a measurement point and rotated around a fixed vertical axis, (or horizontal axis for the tilt measurement) through the focal point of its front lens with a distance as described in B.2.0.5.
2. In landscape mode the display shall be rotated +30 degrees around a vertical axis through the display-glass centre-point and the luminance at positions  $P_L$  and  $P_R$ , ( $L_{P_L/+30/0}$  and  $L_{P_R/+30/0}$  respectively) shall be recorded. See Figure B.2.2.4.2.
3. In landscape mode the display shall then be rotated -30 degrees around the vertical axis through the display-glass centre-point and the luminance at positions  $P_L$  and  $P_R$  ( $L_{P_L/-30/0}$  and  $L_{P_R/-30/0}$  respectively) shall be recorded. See Figure B.2.2.4.2.

4. In landscape mode the display shall then be tilted +15 degrees backwards around a horizontal axis through the display-glass centre-point and the luminance at positions P<sub>T</sub> and P<sub>B</sub> (L<sub>PT/0/+15</sub> and L<sub>PB/0/+15</sub> respectively) shall be recorded. See Figure B.2.2.4.3.
5. In landscape mode the display shall then be tilted -15 degrees forwards around a horizontal axis through the display-glass centre-point and the luminance at positions P<sub>T</sub> and P<sub>B</sub> (L<sub>PT/0/-15</sub> and L<sub>PB/0/-15</sub> respectively) shall be recorded. See Figure B.2.2.4.3.
6. The measurements to be carried out are summarised in Table B.2.2.4.1. The step numbers in the step column correspond with the test method paragraphs.

**Table B.2.2.4.1.**

Reference above test method step	Landscape mode	Screen rotation	Screen tilt	Measuring points			
				P <sub>L</sub>	P <sub>R</sub>	P <sub>T</sub>	P <sub>B</sub>
Step 2	Horizontal direction (turned around vertical axis)	+30°	0°	X	X		
Step 3	Horizontal direction (turned around vertical axis)	-30°	0°	X	X		
Step 4	Backwards tilt = (turned around the horizontal axis)	0°	+15°			X	X
Step 5	Forwards tilt = (turned around the horizontal axis)	0°	-15°			X	X

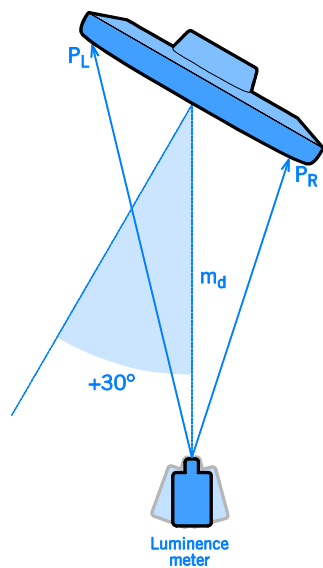

**Figure B.2.2.4.2. Top view of test set-up when the display is rotated  $\pm 30$  degrees. The + rotation is defined clockwise.**

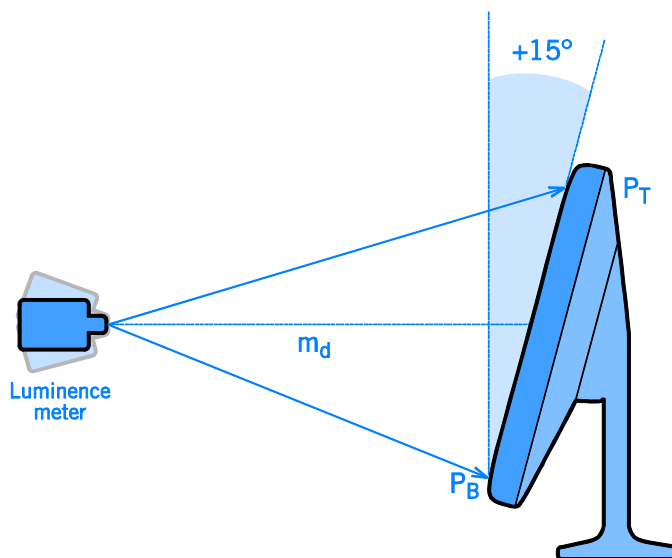

**Figure B.2.2.4.3. Side view of the test set-up when the display is tilted  $\pm 15^\circ$ . The + rotation is defined as backwards.**



#### **B.2.2.4.4 Test evaluation**

The luminance uniformity for angular dependence shall be calculated as follows. In landscape mode, for the horizontal direction, (turned around the vertical axis) measurement presented in Table B.2.2.4.1 (test step 2 and 3). A ratio between the two measured luminances shall be calculated. This ratio, or its inverse if it has a higher value, shall be reported as the requested  $L_{\max}$  to  $L_{\min}$  luminance uniformity in **mandate 1**. The requirement is on the mean value of the two ratios  $+30^\circ$  and  $-30^\circ$ . The result shall be presented to 2 decimal places.

In landscape mode, for the vertical direction (turned around the horizontal axis). Tilt backwards and tilt forwards  $\pm 15^\circ$  test step 4 and 5. A ratio between the two measured luminances shall be calculated. This ratio, or its inverse if it has a higher value, shall be reported as the requested  $L_{\max}$  to  $L_{\min}$  luminance uniformity in **mandate 2**. The requirement is on the larger of the two ratios  $+15^\circ$  and  $-15^\circ$ . The result shall be presented to 2 decimal places.

#### **B.2.2.4.5 Overall uncertainty**

$\leq \pm 10\%$  in luminance.

$\leq \pm 0.3^\circ$  in rotation angle.

$\leq \pm 0.1$  unit in luminance uniformity.

See B.2.0.7.

[Back to A.2.2.4](#)

## B.2.2.5 Greyscale gamma curve

### B.2.2.5.1 Preparation of the projector for testing

- All necessary preparations described in B.0 and B.2.0 shall be done.
- A TCO Certified default test image, as shown in Figure B.0.9.1, shall be used for this measurement.
- The  $4^\circ \times 4^\circ$  square shall have each of the following RGB settings: R=G=B=255, 225, 195, 165, 135, 105, 75 and 45.

### B.2.2.5.2 Equipment

Luminance meter.

### B.2.2.5.3 Test method

Measure the luminance at the centre of the  $4^\circ \times 4^\circ$  square for each greyscale setting specified above. Change the greyscale of the square for each measurement.

### B.2.2.5.4 Test evaluation

The different greyscale luminance levels shall be within the max- and min levels according to the equation or the table below, where 100% means the luminance level measured for white, RGB 255, 255, 255.

#### Comments on the limits tolerance from the sRGB curve

A linear tolerance has been applied symmetrically around the sRGB gamma curve. However, as most displays on the market today have S-shaped gamma curves a “S-correction” has been added to the linear tolerance on the gamma level 225 and 195.

This correction is added since this is a new requirement and the industry needs time to adapt to a gamma curve which is not S-shaped. This correction has been determined based on statistics from measured displays. TCO Development may decide to remove this “S-correction” in the next version of this criteria document.

**Table 2.2.5.1**

Grey level	$L_{sRGB}$	$L_{min}$	$L_{max}$
	%	%	%
255	100	100,0	100,0
225	75	70	93
195	55	46	68
165	38	29	49
135	24	17	36
105	14	8	24
75	7	3	14
45	3	1	7

### B.2.2.5.5 Overall uncertainty

$\leq \pm 10\%$  in luminance.

See B.2.0.7.

[Back to A.2.2.5](#)

## **B.2.3 Luminance contrast characteristics**

### **B.2.3.1 Luminance contrast – characters**

#### **B.2.3.1.1 Preparation of the FPD for testing**

- All necessary preparations described in B.0 and B.2.0 shall be done.
- A micro-photometer for luminance measurement shall be aligned orthogonally to the FPD screen.
- The test image shall be filled with rows of the regular capital letter “H” in 12 point Arial font.

#### **B.2.3.1.2 Equipment**

A micro-luminance meter such as an array photo detector capable of measuring luminance on structures  $\leq 0.02$  mm. Measurement requirements are given in clause B.2.0.2.

#### **B.2.3.1.3 Test method**

- By visual evaluation of the standard test measurement position the technician shall search for and locate visual stripes, or patches, that clearly influence the contrast of characters or even parts of characters. Once the patches are visually identified as having significantly lower contrast they shall be geometrically referenced from the upper left corner of the active image and measured, see below. If one position is found that does not fulfil the mandate, there is no need to make further measurements.
- With a micro-luminance meter or a luminance scanner the luminance signal of and around a vertical stroke of a capital H of 12 point Arial font shall be measured. The optical axis of the luminance meter shall be aligned with the normal of the screen surface at the measuring point. The misalignment between the screen surface normal and the optical axis of the luminance meter shall be less than  $0.3^\circ$ .
- The height (h) of the measuring windows shall be  $1/3$  of the actual height (H) of the character “H”. The window shall be positioned symmetrically between the horizontal stroke and the lower ending of the vertical stroke (see Figure B.2.3.1.1).

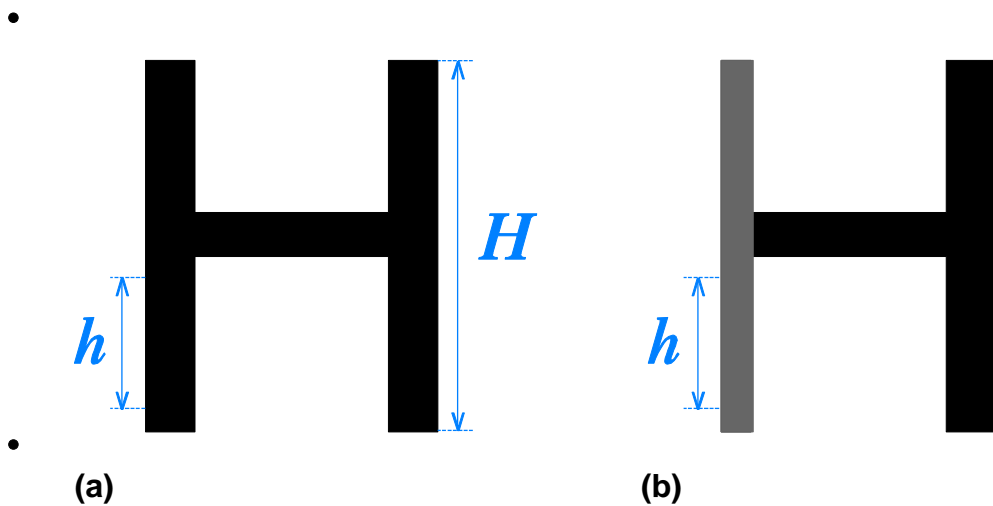

Figure B.2.3.1.1. Example of one capital “H” with (a) good contrast and one with (b) low contrast due to a paler and thinner left vertical stroke. The measuring window having height  $h$  shall be positioned symmetrically between the horizontal stroke and the lower ending of the vertical stroke of the H.

- The physical width of each measuring window or the matrix element shall be less or equal to 1/8 of the pixel size, but not more than 0.02 mm (cf. Figure B.2.3.1.2).

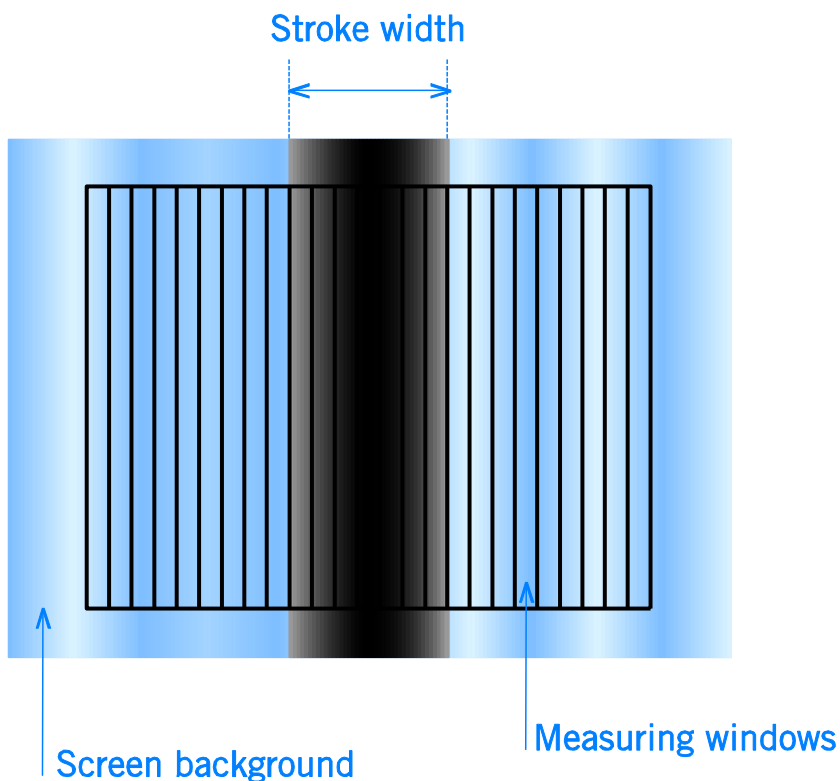
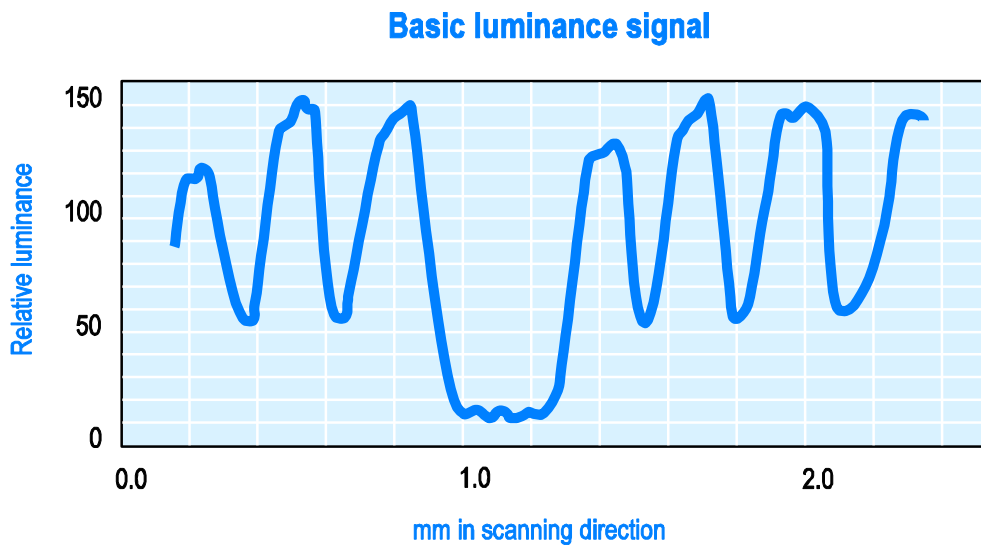

Figure B.2.3.1.2. Magnification of the vertical stroke in Figure B.2.3.1.1(a) showing a number of sampling windows.

- The basic luminance signal scanned from left to right in Figure B.2.3.1.2 could for example be as shown in Figure B.2.3.1.3.



**Figure B.2.3.1.3. Example of a basic luminance signal of a vertical stroke of H.**

**B.2.3.1.4 Test evaluation**

- The basic luminance signal received from the micro-luminance meter depends on the resolution (sampling window size) of the sensor and the pixel size of the display. It is likely that the sampling window size differs between test facilities depending on photometer brand.

- The luminance contrast  $C$  shall be calculated using the formula

$$C = \frac{L_{\max} - L_{\min}}{L_{\max} + L_{\min}}$$

with the maximum and minimum luminances determined as described below.

- The photometer produces a basic luminance signal which can be filtered to a resolution of either 1 or 4 minutes of arc. These filtered signals shall be used for the calculation of  $C$ .
- To find the  $L_{\min}$  proceed as follows: The basic luminance signal shall be filtered to correspond to the 1 minute of arc resolution of the human visual system. This is equal to a sampling window size of 0.145 mm at 500 mm viewing distance. The filtering shall be done by applying a moving average to the basic input data. For example, the 1 minute of arc filtering applied to the luminance signal in Figure B.2.3.1.3 gives the signal in Figure B.2.3.1.4.

1 minute of arc filtered luminance signal used for  $L_{min}$  calculation

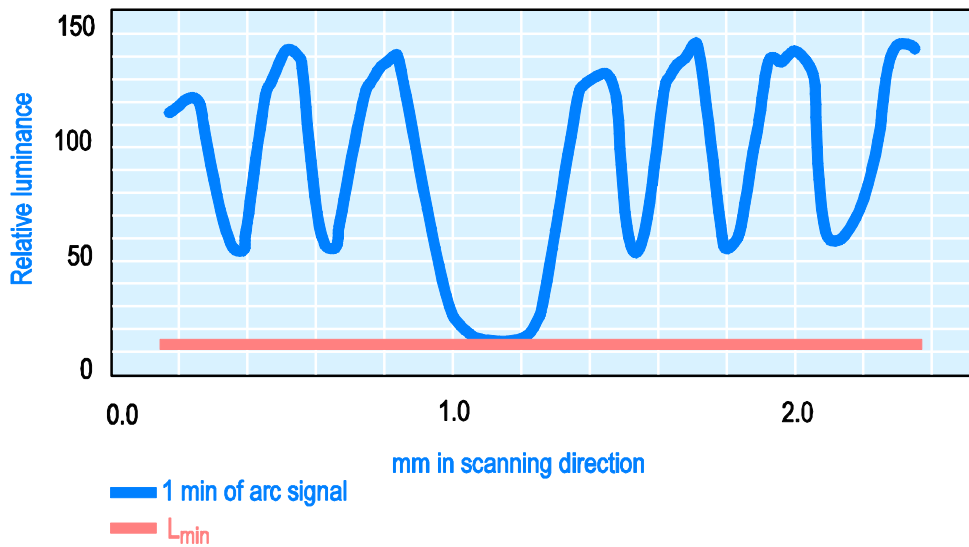

**Figure B.2.3.1.4. The luminance signal filtered to 1 minute of arc and showing  $L_{min}$ .**

- The lowest relative luminance in the vertical stroke in the 1 minute of arc signal is  $L_{min}$ .  
(In the example of Figure B.2.3.1.4, the  $L_{min}$  value is 14 cd/m<sup>2</sup>).
- To find the  $L_{max}$  proceed as follows: The 4 minute of arc signal filtering shall be obtained by applying a moving average to the 1 minute of arc signal. This corresponds to a more comfortable viewing condition. The filtered luminance signal is shown in Figure B.2.3.1.5.

**4 minutes of arc filtered luminance signal used for  $L_{max}$  calculation**

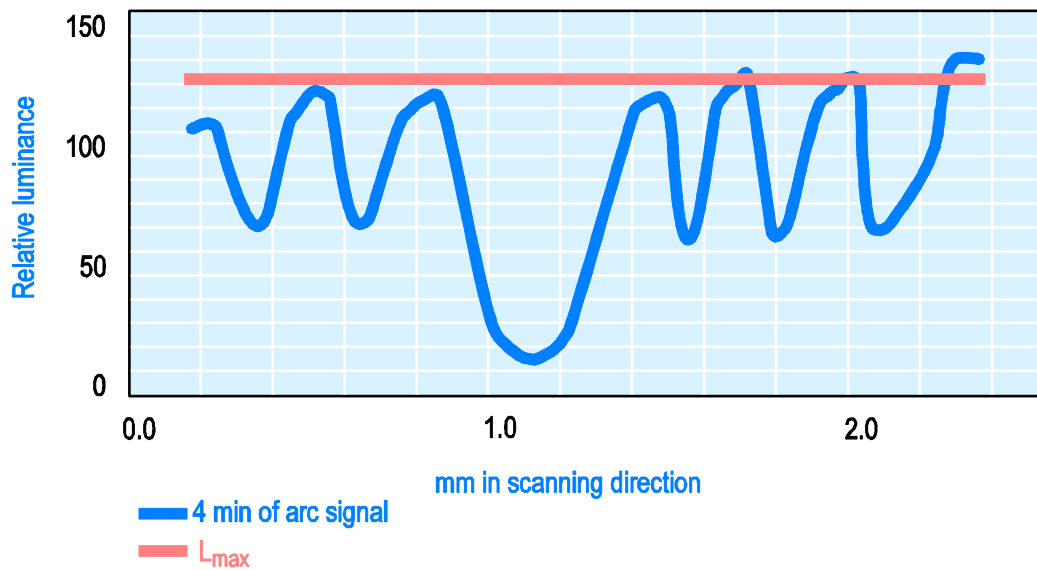

**Figure B.2.3.1.5. The 1 minute of arc luminance signal filtered to 4 minutes of arc and showing  $L_{max}$ .**

- The maximum luminances may be different on the two sides of the H stroke. Select the lower one as  $L_{max}$ .

(In the example of Figures B.2.3.1.4 and B.2.2.1.5 the luminance is lower on the left side than the right side and thus

$L_{max} = 127 \text{ cd/m}^2$ . With  $L_{min} = 14 \text{ cd/m}^2$  the contrast is  $C = (127 - 14) / (127 + 14) = 0.80$ ).

The lowest luminance contrast found shall be reported.

The result shall be presented to 2 decimal places.

**B.2.3.1.5 Overall uncertainty**  
 $\leq \pm 0.05$  in contrast.

See B.2.0.7.

[Back to A.2.3.1](#)

## **B.2.3.2 Luminance contrast – angular dependence**

### **B.2.3.2.1 Preparation of the FPD for testing**

- All necessary preparations described in B.0 and B.2.0 shall be done.
- A TCO Certified default test image, as shown in Figure B.0.9.1, shall be used for this measurement.
- The  $4^\circ \times 4^\circ$  square shall have each of the following RGB settings: (RGB 255, 255, 255) and (RGB 0, 0, 0).

### **B.2.3.2.2 Equipment**

Luminance meter.

### **B.2.3.2.3 Test method**

- The luminance meter shall be positioned and directed orthogonally to the screen centre-point as described in B.2.0.5.
- The FPD shall be rotated around a vertical axis through the screen front centre, changing the azimuth angle to  $+30^\circ$ . The luminance of the white square  $L_{W+30}$  and the luminance when the square is black  $L_{B+30}$  at the centre shall be recorded.
- Finally the azimuth angle of the screen shall be changed to  $-30^\circ$  and the new measurements  $L_{W/-30}$  and  $L_{B/-30}$  taken.

### **B.2.3.2.4 Test evaluation**

The luminance contrast values  $C_{+30}$  and  $C_{-30}$  shall be calculated using the formula

$$C = \frac{L_W - L_B}{L_W + L_B}$$

Of  $C_{+30}$  and  $C_{-30}$ , only the lowest value shall be reported as the luminance contrast.

### **B.2.3.2.5 Overall uncertainty**

$\leq \pm 10\%$  in luminance.

$\leq \pm 0.05$  in contrast.

See B.2.0.7.

[Back to A.2.3.2](#)



## **B.2.4 Screen colour characteristics**

### **B.2.4.1 Correlated colour temperature (CCT) variation**

#### **B.2.4.1.1 Preparation of the FPD for testing**

- All necessary preparations described in B.0 and B.2.0 shall be done.
- A TCO Certified default test image, as shown in Figure B.0.9.1, shall be used for this measurement.

#### **B.2.4.1.2 Equipment**

Spectro-radiometer capable of presenting CIE  $u'$  and  $v'$  chromaticity co-ordinates with at least three decimals.

#### **B.2.4.1.3 Test method**

The spectral properties at the centre of the test square shall be measured with a spectro-radiometer.

The spectral data shall then be processed, which is normally done directly in the instrument microprocessor, to give chromaticity co-ordinates. In this case the CIE co-ordinates  $u'$  and  $v'$  are needed for the test evaluation and are often presented directly by the spectro-radiometer used.

If the client has stated more than two pre-set CCTs, preparation and testing shall be repeated for the additional CCTs.

The following rules shall apply:

- Only CCTs with exactly specified numerical values have to fulfil the requirements.
- CCTs lower than 5000 K shall not be tested.

**B.2.4.1.4 Test evaluation**

The measured  $u'_m$  and  $v'_m$  values of the screen for the pre-set CCT and the CIE reference chromaticity co-ordinates  $u'_{CCT}$  and  $v'_{CCT}$  values for the reported CCT shall be used to calculate the colour difference as follows:

$$\Delta u'v' = \sqrt{(u'_{CCT} - u'_m)^2 + (v'_{CCT} - v'_m)^2}$$

This calculation shall be done for all tested pre-set CCTs.

Most FPDs are delivered with two or more pre-set CCTs for a white screen. These pre-set CCTs are often one or more of the following; 9300 K, 7500 K, 6500 K, 5500 K and 5000 K. The CIE 1976  $u'$  and  $v'$  reference chromaticity co-ordinates for the five mentioned CCTs are given in Table B.2.4.1.1.

**Table B.2.4.1.1**

CCT in K	$u'_{cct}$	$v'_{cct}$
9300	0.1888	0.4457
7500	0.1935	0.4586
6500 (sRGB)	0.1978	0.4684
5500	0.2044	0.4808
5000	0.2091	0.4882

If preset CCTs other than those given in Table B.2.4.1.1 are used in the test,  $u'_{CCT}$  and  $v'_{CCT}$  can be found by using CIE tabulated data or by using CIE formulae presented in CIE Publication 15.2 (1986), Colorimetry, p.11, p. 27-28 and p. 53-54, Table 1.3.

If the spectro-radiometer used only can produce CIE 1931  $x$  and  $y$  chromaticity co-ordinates these can be transformed to  $u'$  and  $v'$  chromaticity co-ordinates by using the formulae in the CIE Publication 15.2 mentioned above.

The relevant CIE material – conversion formulae and tabulated data for  $u'_{CCT}$  and  $v'_{CCT}$  – can also be found on the TCO Development homepage, [www.tcodevelopment.com](http://www.tcodevelopment.com). A computer program based on the given equations can be supplied by TCO Development.

The resulting colour difference calculation shall be presented to 3 decimal places.

**B.2.4.1.5 Overall uncertainty**

$\leq \pm 0.003$  in  $u'$  and  $v'$ .

See B.2.0.7.

[Back to A.2.4.1](#)

## B.2.4.2 Colour uniformity

### B.2.4.2.1 Preparation of the FPD for testing

- All necessary preparations described in B.0 and B.2.0 shall be done.
- The entire active area of the screen shall be white and the FPD colour setting shall be RGB 255, 255, 255.

### B.2.4.2.2 Equipment

Spectro-radiometer with a capacity to present u' and v' co-ordinates with at least 3 decimals.

### B.2.4.2.3 Test method:

The colour uniformity shall be measured orthogonally to the FPD screen plane at 9 points. The 4 corner positions (1, 3, 7 and 9) are measured 1° from the edges of the screen as shown in Figure B.2.2.2.1. The 4 side positions (2, 4, 6 and 8) are measured on the middle of the side 1° from the edge. These measurement points have a 1/2° margin to the edges if the measurement area of the instrument is 1° (see figure B.2.2.2.1). Finally the centre position (5) is measured.

The colour uniformity shall also be evaluated visually by the technician in order to find those areas where the colour varies the most except from the 9 default positions. If a significant difference within the 1° from the edge area is found these measuring points shall also be measured and used to evaluate the colour uniformity.

The conditions for colour measurement in the corner positions and the distribution of other measurement points are illustrated in Figure B.2.2.2.1.

### B.2.4.2.4 Test evaluation

$\Delta u'v'$  according to the CIE (1976) uniform chromaticity scale diagram shall be calculated for each measured position using the formula

$$\Delta u'v' = \sqrt{(u'_A - u'_B)^2 + (v'_A - v'_B)^2}$$

where A and B are the two points found to have the largest colour difference between them.

The largest difference in  $\Delta u'v'$  value shall be reported.

The result shall be presented to 3 decimal places.

(The evaluation procedure is exemplified below

- Make a table of colour chromaticity values for each measured position

Measurement position no.	$u'$	$v'$
1	0.190	0.447
2	0.186	0.441
3	0.186	0.437
-	-	-
-	-	-
n-1	0.185	0.434
n	0.186	0.432
<b>Largest difference</b>	<b>0.005 in this example</b>	<b>0.015 in this example</b>

- The largest  $u'$  difference,  $\Delta u'$ , is 0.005 (between 0.190 and 0.185) at measurement positions 1 and n-1.
- The largest  $v'$  difference,  $\Delta v'$ , is 0.015 (between 0.447 and 0.432) at measurement positions 1 and n.
- Since  $\Delta v'$  (= 0.015) is much larger than  $\Delta u'$  (= 0.005), the  $\Delta v'$  value shall be used for the calculation of  $\Delta u'v'$ .
- The corresponding two pairs of  $u'$  and  $v'$  to be used for the calculation are thus the values found at position 1 and position n and thus become the values used for points A and B such that

$$u'_1 = u'_A = 0.190 \text{ and } v'_1 = v'_A = 0.447 \text{ for point A in this example}$$

and

$$u'_n = u'_B = 0.186 \text{ and } v'_n = v'_B = 0.432 \text{ for point B in this example}$$

Hence  $\Delta u'v' = \sqrt{0.000016 + 0.000225} = 0.01552$ , which shall be reported as 0.016.)

#### B.2.4.2.5 Overall uncertainty

$\leq \pm 0.003$  in  $u'$  and  $v'$ .

See B.2.0.7.

[Back to A.2.4.2](#)

### B.2.4.3 RGB settings

#### B.2.4.3.1 Preparation of the FPD for testing

- All necessary preparations described in B.0 and B.2.0 shall be done.
- A TCO Certified default test image, as shown in Figure B.0.9.1, shall be used for this measurement.
- The  $4^\circ \times 4^\circ$  square shall have each of the following RGB settings:  
 (255, 0, 0) for red,  
 (0, 255, 0) for green,  
 (0, 0, 255) for blue.

#### B.2.4.3.2 Equipment

Spectroradiometer with a capacity to present  $u'$  and  $v'$  coordinates with at least 3 decimals.

#### B.2.4.3.3 Test method

The instrument shall be directed orthogonally towards the different test square centres at the measurement distance described in B.2.0.5. Measure the chromaticity co-ordinates at the centre of the  $4^\circ \times 4^\circ$  square for each colour setting specified above or the alternative larger test square image (80% of the full screen mode) described in B.0.9 may be used for these measurements.

Change the colour of the square for each measurement.

Reference colour co-ordinates are based on sRGB: Red ( $u'0.451/v'0.523$ ), Green ( $u'0.125/v'0.563$ ), Blue ( $u'0.175/v'0.158$ ) which corresponds to 33.3% of the total CIE 1976 uniform chromaticity scale diagram (100% sRGB and 87% Adobe RGB)

#### B.2.4.3.4 Test evaluation

##### Mandate 1.

Calculate the colour gamut using the equation below.

$$A (\%) = 256.1 |(u'R - u'B)(v'G - v'B) - (u'G - u'B)(v'R - v'B)|$$

The indexes R, G and B are short for Red, Green and Blue.

Example: The following reading gives a gamut of  $A = 31.65\%$

Red  $u'/v' = 0,436/0,526$

Green  $u'/v' = 0,132/0,572$

Blue  $u'/v' = 0,181/0,158$

##### Mandate 2.

The recorded chromaticity co-ordinates  $u'$  and  $v'$  for the Red, Green and Blue squares shall be reported.

The  $u'$  and  $v'$  shall be presented to 3 decimal places.

#### B.2.4.3.5 Overall uncertainty

$\leq \pm 0.003$  in  $u'$  and  $v'$  for red and green.

$\leq \pm 0.007$  in  $u'$  and  $v'$  for blue.

See B.2.0.7.

[Back to A.2.4.3](#)

## B.2.4.4 Colour uniformity – angular dependence

### B.2.4.4.1 Preparation of the FPD for testing

- All necessary preparations described in B.0 and B.2.0 shall be done.
- The screen background shall be RGB 204, 204, 204.
- Chromaticity co-ordinates  $u'$  and  $v'$  shall be measured at three different positions on the screen as shown in Figure B.2.4.4.1. Each measurement position shall consist of white RGB 255, 255, 255 squares sized  $4^\circ \times 4^\circ$ .
- The spectro-radiometer shall be positioned and directed orthogonally to the screen centre-point as described in B.2.0.5.

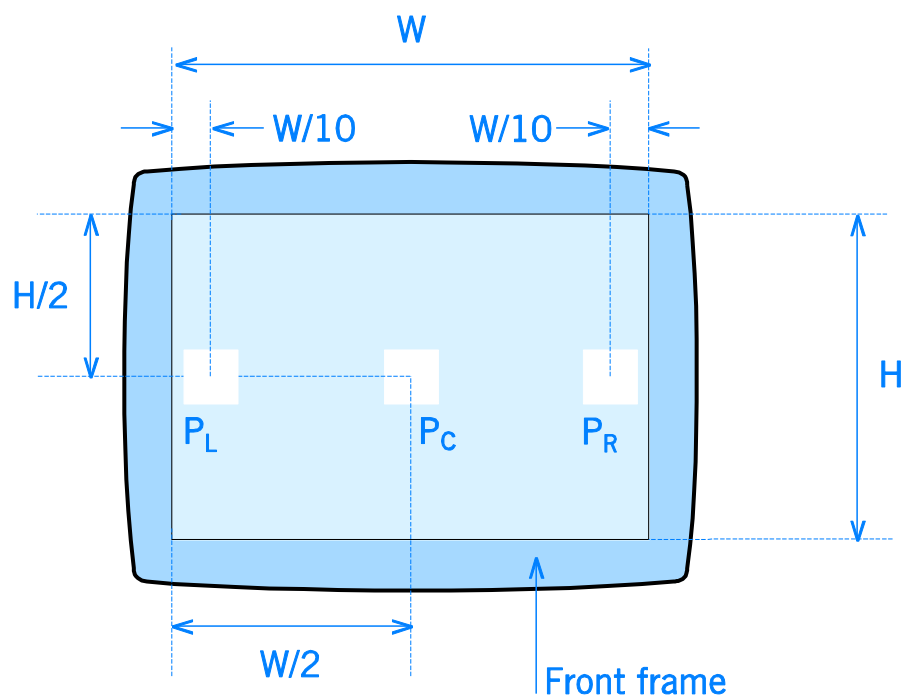

Figure B.2.4.4.1. Measurement positions for colour uniformity-angular dependence.

### B.2.4.4.2 Equipment

Spectro-radiometer with a capacity to present  $u'$  and  $v'$  co-ordinates with at least 3 decimals.

### B.2.4.4.3 Test method

- The spectro-radiometer shall always be directed towards a measurement point and rotated around a fixed vertical axis, (or horizontal axis for the tilt measurement) through the focal point of the front lens with a distance as described in B.2.0.5.
- The spectro-radiometer shall be turned towards positions  $P_L$  and  $P_R$  and focused. The colour co-ordinates at positions  $P_L$  and  $P_R$  ( $u'_{P_L/0}$ ,  $v'_{P_L/0}$  and  $u'_{P_R/0}$ ,  $v'_{P_R/0}$  respectively) shall be recorded.
- The screen shall then be rotated +30 degrees around a vertical axis through the screen centre-point and the chromaticity co-ordinates at positions  $P_L$ ,  $P_R$ , ( $u'_{P_L/+30}$ ,  $v'_{P_L/+30}$  and  $u'_{P_R/+30}$ ,  $v'_{P_R/+30}$  respectively) shall be recorded.

- The screen shall finally be rotated -30 degrees around a vertical axis through the screen centre-point and the chromaticity co-ordinates at positions P<sub>L</sub>, P<sub>R</sub>, (u'<sub>PL/-30</sub>, v'<sub>PL/-30</sub> and u'<sub>PR/-30</sub>, v'<sub>PR/-30</sub> respectively) shall be recorded.
- Pivot screens shall only be measured in the usual landscape mode.

#### B.2.4.4.4 Test evaluation

Δu'v' according to the CIE (1976) uniform chromaticity scale diagram shall be calculated for each measured position using the formula

$$\Delta u'v' = \sqrt{(u'_A - u'_B)^2 + (v'_A - v'_B)^2}$$

where A and B are the two points found to have the largest colour difference between them.

The largest difference in Δu'v' value shall be reported

The result shall be presented to 3 decimal places.

(The evaluation procedure is exemplified below)

- Make a table of chromaticity values for each measurement position and calculate Δu'v' for +30° for and -30°

Measurement position no.	Example value u'	Example value v'
PL /+30	0.190	0.447
PR /+30	0.187	0.442
Difference at +30°	0.003	0.005
Δu' v' at +30°	0.0059	
Measurement position no.	Example value u'	Example value v'
PL /-30	0.182	0.436
PR /-30	0.189	0.432
Difference at -30°	0.007	0.004
Δu' v' at -30°	0.0081	
Largest difference Δu'v'	0.0081 in this example	

The largest calculated Δu'v' difference is 0.0081 when the screen is rotated -30°. The test value to be reported is this value, reported to 3 decimal places, thus 0.008.

#### B.2.4.4.5 Overall uncertainty

≤ ± 10% in luminance.

≤ ± 0.003 units for u' and v'.

≤ ± 0.3° in rotation angle.

See B.2.0.7.

[Back to A.2.4.4](#)

## B.2.4.5 Colour greyscale linearity

### B.2.4.5.1 Preparation of the FPD for testing

- All necessary preparations described in B.0 and B.2.0 shall be done.
- A TCO Certified default test image, as shown in Figure B.0.9.1, shall be used for this measurement.
- The  $4^\circ \times 4^\circ$  square shall have each of the following RGB settings: R=G=B= 255, 225, 195, 165, 135, 105, 75, 45.

### B.2.4.5.2 Equipment

Spectro-radiometer with a capacity to present  $u'$  and  $v'$  co-ordinates with at least 3 decimals.

### B.2.4.5.3 Test method

The instrument shall be directed orthogonally towards the different test square centres at the measurement distance described in B.2.0.5. Measure the chromaticity co-ordinates at the centre of the  $4^\circ \times 4^\circ$  square for each greyscale step specified above. Change the greyscale of the square for each measurement.

### B.2.4.5.4 Test evaluation

The evaluation procedure is exemplified below

- TCO Development will provide an excel spread sheet at the TCO Development website [www.tcodevelopment.com](http://www.tcodevelopment.com) which will calculate the  $\Delta u' v'$  differences between all the greyscale levels according to the equation:

$$\Delta u'v' = \sqrt{(u'_A - u'_B)^2 + (v'_A - v'_B)^2}$$

- Fill in the chromaticity values of  $u'$  and  $v'$  for each measured greyscale step into the corresponding cells of the spread sheet.

The table A.2.4.5 contains coloured cells indicating difference requirements. The principle is that the darker the greyscale the more difficult it is to see a colour difference.

Examples on how to use the table: By using the column 255 (greyscale 255) and go down to line 165 (greyscale 165) you find that the maximum allowed colour difference  $\Delta u' v'$  is 0.020 (orange cell). For the greyscales 225 and 75 the maximum allowed difference is 0.030 (green cell).

### B.2.4.5.5 Overall uncertainty

$\leq \pm 10\%$  in luminance.

$\leq \pm 0.003$  units for  $u'$  and  $v'$ .

See B.2.0.7.

[Back to A.2.4.5](#)



## B.3 Workload ergonomics

### B.3.1 Vertical tilt

It shall be possible to obtain a display tilt of at least 20° backwards from an upright position (vertical plane) in at least one of the height positions.

The measurement of 20 degrees backwards tilt starts from the vertical plane (0 degrees). Some displays may have a starting position (minimal tilt) that is already tilted backwards, for example 5 degrees, if this is the case then it is necessary to be able to tilt the display another 15 degrees to achieve the full 20 degree requirement. However the starting position (minimal tilt) shall not be more than 10 degrees backward.

1° test tolerance is allowed. This is a tolerance for test set up and not for the test sample.

[Back to A.3.1](#)

### B.3.2 Vertical height

The height requirement level under mandate 1 is set on documented anthropometric data for the eye height variance for 2.5-97.5 percentile of adults. The shortest distance between eye and working surface level is taken from the 2.5 percentile of adults. The distance is from the operator's elbow (work surface height) to eye level. With a maximum height measurement set for displays that cannot be height adjusted these operators will avoid the need to extend the neck backwards when scanning the screen.

The height of the population in the US and Europe has been documented in the “humanscale”

- The 2.5 percentile of the population in these regions is 145cm. According to the “humanscale” this gives an eye height of 42cm from the table top surface.
- The height measurement shall be taken with the display in normal (non-tilted) position standing directly on a flat surface and at the lowest point of height adjustment. The measurement shall be taken from the table surface to the upper edge of the active screen area – see figure B.3.2
- For the moment the criterion is based on the “humanscale” but as more relevant Anthropometrical data becomes available the criterion may be revised.

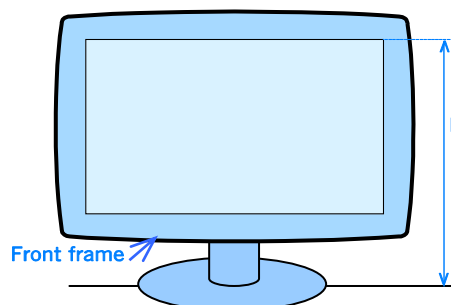

H Figure B.3.2 vertical height measurement

[Back to A.3.2](#)

## B.4 Emissions

### B.4.0 General test conditions for emissions

#### B.4.0.1 Basic test requirements

As described in section B.0.

For the test methods for emissions described in this document the following conditions apply:

- AC mains voltage\* 230 VAC RMS, tolerance  $\leq 1\%$
- AC mains frequency\* 50 Hz, tolerance  $\leq 2\%$
- Test room temperature  $23\pm 3\text{ }^{\circ}\text{C}$
- Humidity 20-75 % RH (non condensing)

The equipment shall be connected to phase and neutral.

\* – or other voltage and frequency combination specified by the client.

#### B.4.0.2 Conditions and set up for the test object

The tests shall be performed with the full screen size activated.

The FPD control settings shall be the same as for visual ergonomics. This means that the default setting at reset shall be used for the emission testing of alternating electric and magnetic fields the luminance at this setting shall be  $\geq 150\text{ cd/m}^2$ . See section B.0.9 for details concerning this setting.

The FPD shall during the measurements show a full screen of capital “H” pattern in dark/black Arial letters on a luminated background (positive polarity), see section B.0.8 for details concerning this setting.

Any pivot FPD that can be used in both normal landscape position and portrait position (turned  $90^{\circ}$ ) shall have measurements taken in both positions. The worst case shall be reported.

Any FPD equipped with a height-adjustable stand shall have measurements taken in both the lowest and highest positions. Both measurements shall be done with the measurement instrument positioned to the centre-centre point of the screen surface. The worst case shall be reported.

The FPD must normally comply with the mandatory requirements without having to rely on an earth connection via the signal cable. Only if the FPD gets all its power through the signal cable, then it may also rely on its earth connection through the signal cable. In order to test a FPD without an earth connection via the power cable, a battery operated computer, with no connection to earth, can be used to operate the FPD.

If the FPD is connected to mains via a detachable mains cord, the measurement shall be performed with a shielded mains cord (connected to earth for CLASS I device). Most shielded power cords have the text “shielded” printed on them. The quality of the shielding shall be verified in the following way:

Bend the cable in half and put the bended point of the cable in the centre of the turn table and both the connectors hanging down behind the turn table. Put the antenna 30cm above and 30cm in front of the centre of the turn table.

Connect one side of the cable to mains and measure the alternating electric field of the cable. The values shall be below (5.0 V/m in band I and 0.20 V/m in band II).

An FPD without an external power supply shall be connected to mains via the above mentioned power cable. The power cable and signal cable shall run from the points of connection on the FPD and then horizontally straight to a point 0.4 m behind the screen surface. The cables shall then from this point run downwards at least 1 m. – see figure B.4.0.2.1. The power and signal cables may not be placed together unless the FPD is provided with an integrated cable holder. When an integrated cable holder is present it shall be used for the test to secure the cables.

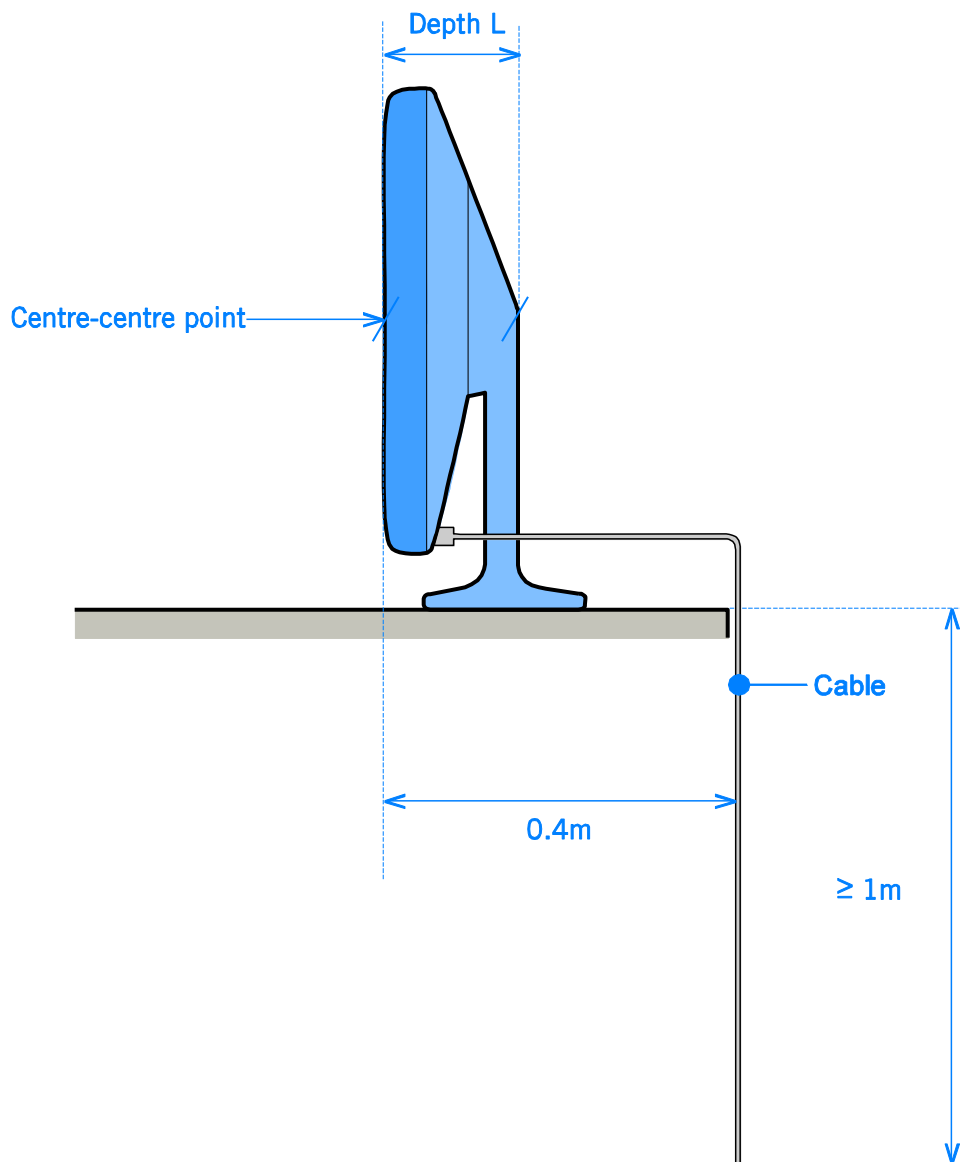

**Figure B.4.0.2.1 FPD without external power supply unit.**

The external power supply unit, if any, will contribute to the electromagnetic fields around the FPD. Power supply units, which are connected via a primary cable to the outlet, shall be positioned centrally, directly behind the test sample, on the (turn)table, with the secondary side towards the FPD, see Figure B.4.0.2.2. The primary cable shall extend horizontally, on the (turn)table to a point 0.4 m behind the screen surface. The cable shall then, from this point run downwards at least 1 m. If the power supply can be positioned with different sides up, it shall be tested in all positions and the worst case shall be used. However, if it is obvious which side is intended to be the top side or bottom side by the placement of LED indicator or integrated supports to stand on, it is enough to test the power supply in the one intended position.

The secondary cable of the power supply shall run the shortest distance from the point of its connection on the FPD to the secondary side of the power supply. The

unused portion of the secondary cable, if any, shall be bundled together with the power supply unit. The bundle loops shall have a length equal to the longest dimension of the power supply. For supply units with dimensions less than 0.1 m, a 0.1 m bundle loop length shall be used.

For power supply units which are designed to be attached to the FPD bezel or directly in the outlet without a primary cable, the secondary cable shall in these cases run vertically down to the (turn)table from the point of its connection on the FPD and then horizontally straight to a point 0.4 m behind the screen surface. The cable shall then, from this point, run downwards at least 1 m.

If the FPD bezel has an integrated external power supply holder, this shall be used during the test and the cables placed according to the set-up conditions for a FPD without external power supply as described above, if the FPD does not have an integrated cable holder. When an integrated cable holder is present then it shall be used for the test to secure the cables.

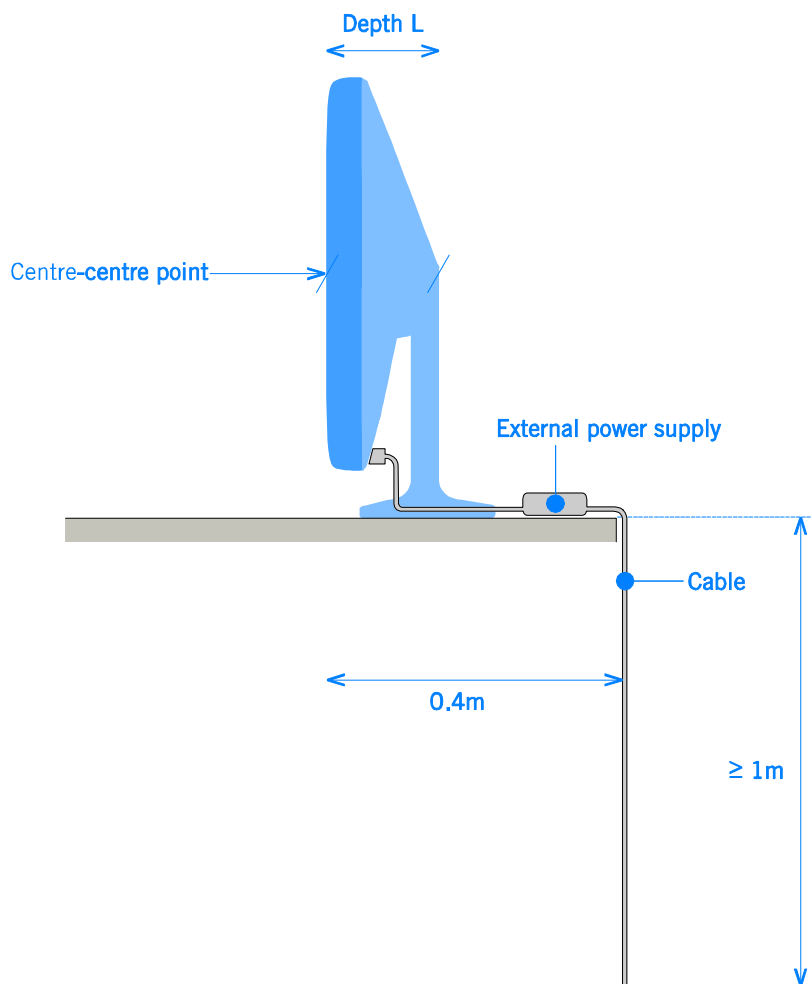

**Figure B.4.0.2.2 FPD with external power supply units.**

Note! For pivot FPDs and FPDs equipped with height-adjustable stands, the cable has to be adjusted for the different positions.

For measurements of alternating magnetic fields (B.4.2) the power cable need not be a shielded power cable and it may be positioned in another way, as the cable

contributes a negligible amount to the magnetic field. However external power supplies must be correctly positioned behind the FPD, as they may give rise to magnetic fields.

If positioning according to the above rules is not possible, then the positioning of the external power supply and cables shall be described in the test report.

### B.4.0.3 Emission measurement instruments

The instruments used for emission testing shall comply with the requirements and calibration procedures described below:

#### Alternating electric field meter

The alternating electrical field emission from the FPD under test shall be determined by measuring the displacement current passing a given surface of the measuring probe. The probe consists of a disc of double sided printed circuit board laminate with a diameter of 300 mm. On the front of the board the copper layer is removed in the annulus between radii 50 and 52 mm, see Figure B.4.0.3.1.

The copper foil surrounded by the annulus is the active measuring surface. It is connected to one input terminal of an operational amplifier, with capacitive feedback. The other input terminal of the operational amplifier, the copper ring outside the active surface, and the back of the board are connected to ground. The output voltage (U) from the probe (active surface with area (A)) is related to the incident electrical field, E, averaged over the active surface according to  $U = \epsilon \cdot E \cdot A/C$  where C is the capacitance in the feedback loop of the operational amplifier and  $\epsilon$  is the permittivity for a vacuum.

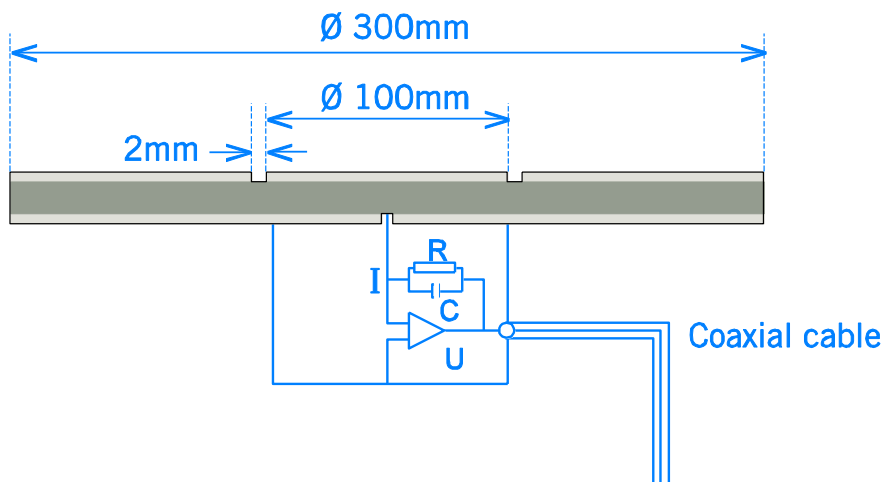

**Figure B.4.0.3.1 Sketch and circuit principle of the Alternating electric field meter for alternating electrical field measurements. The feedback circuit of the operational amplifier is a capacitance C in parallel with a high value resistor R to ensure that there is no DC voltage across the plates of the capacitor C.**

The specifications for the frequency response of the measuring probe are given by the calibration procedure. The signals from the probe shall be filtered by high-pass and low-pass filters. The specification of the filters is given in Table B.4.0.3.1.

**Table B.4.0.3.1 Filter specifications**

<b>Frequency Band I</b>					
<b>Frequency</b>	< 5 Hz	5 Hz	100 Hz	2 kHz	> 2 kHz
<b>Attenuation</b>	> 80 dB/decade	3 dB	0 dB	3 dB	> 40 dB/decade

<b>Frequency Band II</b>					
<b>Frequency</b>	< 2 kHz	2 kHz	30 kHz	400 kHz	> 400 kHz
<b>Attenuation</b>	> 80 dB/decade	3 dB	0 dB	3 dB	> 40 dB/decade

After amplification and filtering the output voltage of the measuring probe shall be used to determine the r.m.s. value of the electric field strength in both frequency bands.

The measuring time shall be sufficiently long to enable measurements with an accuracy of  $\pm 5\%$  at 50/60 Hz.

The measuring system shall be capable of measuring at least down to 2.0 V/m in band I and down to 0.20 V/m in band II.

The measuring probe shall be calibrated using a parallel plate capacitor (air dielectric) consisting of the measuring probe and a metal plate of at least 300 mm diameter. The distance between the surface of the probe and the plate shall be 30 mm.

The calibration shall be performed with sinusoidal fields at the amplitudes and frequencies specified in Table B.4.0.3.2.

**Table B.4.0.3.2 Calibration frequencies and amplitudes**

	<b>Frequencies</b>	<b>Amplitude</b>
<b>Band I</b>	50, 100, 500, 1000 Hz	10, 25 V/m
<b>Band II</b>	15, 30, 60, 120 kHz	1.0, 2.5, 10 V/m

Recorded values at these calibration points shall be within  $\pm 5\%$  of the nominal value. Due to the nature of the specified filters the deviation shall be calculated at 1 kHz from 9.5 and 22.5 V/m and at 120 kHz from 0.95, 2.4 and 9.5 V/m.

**Alternating magnetic field meter in band I and band II**

The magnetic field shall be measured using coil systems that shall consist of three mutually perpendicular concentric circular coils each with an area of 0.01 m<sup>2</sup>. The coils may depart from a circular shape where they intersect. The minimum inner diameter shall be 110 mm and the maximum outer diameter 116 mm. The measuring coils shall not be sensitive to electric fields.

The resonance frequency of each coil appropriately connected to cables and amplifiers shall not be so low that it may influence the specified frequency response according to table B.4.0.3.1.

Amplifiers and integrating networks to make the output voltage proportional to the magnetic flux density and independent of frequency shall follow each coil. The

specifications in respect of the frequency response are given in the calibration procedure.

High-pass and low-pass filters shall filter the signals from the coil systems. The specifications of the filters are given in Table B.4.0.3.1.

After amplification, integration and filtering, the signals from the three coils in each coil set shall be used as input values for calculating the r.m.s. values of the amplitudes of the magnetic flux density vectors in both frequency bands. It is permissible to calculate the r.m.s. value for each of the coil signals and use the root of the squared sum of those r.m.s. values as the test result.

The measuring time shall be sufficiently long to enable measurement with an accuracy of  $\pm 5\%$  at 50/60 Hz.

The alternating magnetic field meter in band I and band II shall be capable of measuring down to at least 40 nT in band I and down to 5.0 nT in band II.

The alternating magnetic field meter in band I and band II shall be calibrated using a Helmholtz-type calibration coil as shown in the Figure B.4.0.3.2. Calibration set-up. Calibration shall be performed with sinusoidal fields at the amplitudes and frequencies specified in Table B.4.0.3.3.

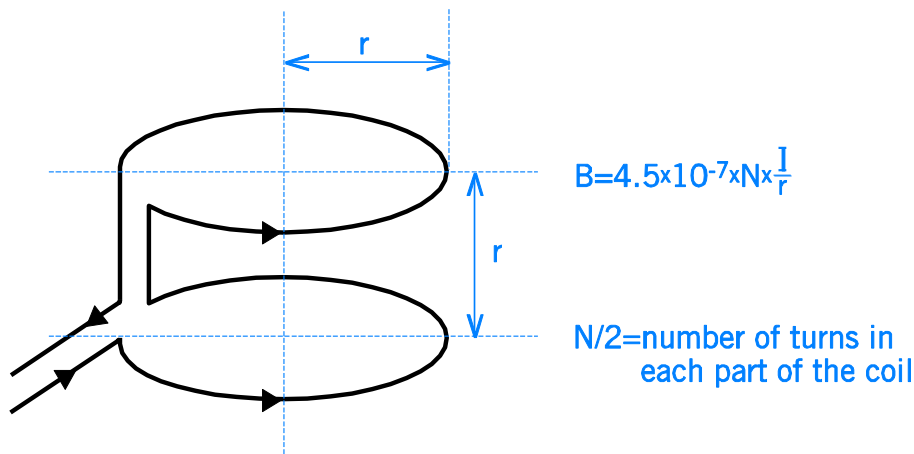

**Figure B.4.0.3.2. Calibration using a Helmholtz-type calibration coil.**

**Table B.4.0.3.3 Calibration frequencies and amplitudes**

	Frequencies	Amplitudes
<b>Band I</b>	60, 100, 500, 1000 Hz	200, 2000 nT
<b>Band II</b>	15, 30, 60, 120 kHz	25, 250 nT

Recorded values for these calibrations shall not deviate more than  $\pm 5\%$  from the nominal value. Due to the nature of the specified filters the deviation at 1 kHz shall be calculated from 180 nT and 1800 nT and at 120 kHz from 24 nT and 240 nT.

The calibration shall be performed for each of the three individual coils separately exposed and for one situation where approximately the same flux density passes through all three coils.



## **B.4.1 Alternating electric fields**

### **B.4.1.0 Test facility requirements**

Background electric field strengths in the test facility, including disturbances transmitted by power lines and internally generated noise in the measuring system, shall together not exceed 2.0 V/m in band I and 0.20 V/m in band II.

The mains voltage to the FPD under test shall be within  $\pm 3 \%$  of its nominal value.

### **B.4.1.1 Preparation of the FPD for testing**

All necessary preparations described in B.0 and B.4.0 shall be done.

An external optical filter may not be used in order to comply with the mandatory requirement.

### **B.4.1.2 Equipment**

Alternating electric field meter

### **B.4.1.3 Test Method**

The true r.m.s.-value of the amplitude of the electric field strength, at the surface of the measuring probe, is measured in front of the test object in band I and in four azimuths in band II. The frequency ranges are selected by means of filters in the measuring equipment.

#### **Screens smaller or equal to 26"**

The FPD shall be positioned such that the tangential plane, to the centre-centre point of the screen surface, is at a right angle to the horizontal plane. The distance between the centre-centre points of the screen surface and the back of the FPD, including an eventual part of a stand holder, along the normal to this tangential plane is called L, see Figure B.4.1.3.1.

The origin of the cylindrical co-ordinate system is chosen to be situated at a distance  $L/2$  behind the screen surface on the normal to the tangential plane through the centre-centre point. The z-axis is chosen to be at a right angle to the horizontal plane. The angular reference direction is along the above mentioned normal in the direction pointing outwards from the screen. An angle ( $\vartheta$ ) is positive in the counter-clockwise direction. The measurement instrument is moving in a counter-clockwise direction around the test sample (as illustrated in the figure B.4.1.3.1).

Measurements shall be made at all points which have a minimum clearance of 0.25 m to the outer surface of the FPD and with co-ordinates according to:

$$z = 0$$

$$r = (L/2 + 0.5) \text{ m (at the front also } (L/2 + 0.3) \text{ m)}$$

$$\vartheta = 0^\circ \text{ for band I}$$

$$\vartheta = 0^\circ, 90^\circ, 180^\circ \text{ and } 270^\circ \text{ for band II}$$

In case of less than 0.25 m clearance the instrument shall be moved out radial until 0.25 m clearance is achieved.

Distances are given in metres and angles in degrees. The co-ordinates are given for the centre of the measuring probe. The surface of the probe shall be perpendicular, within  $\pm 5^\circ$ , to the radial axis.

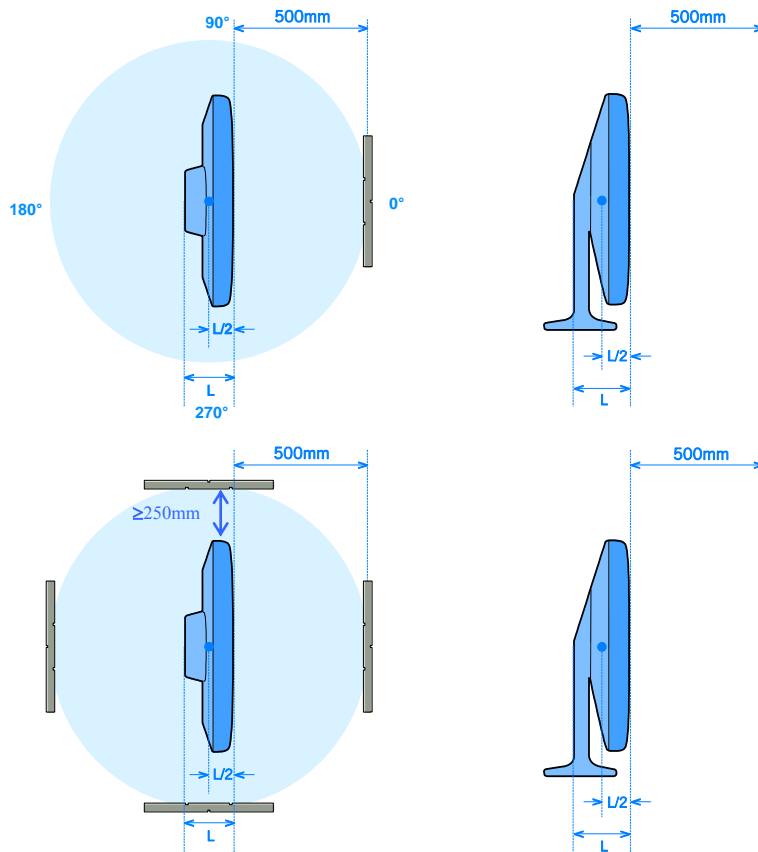
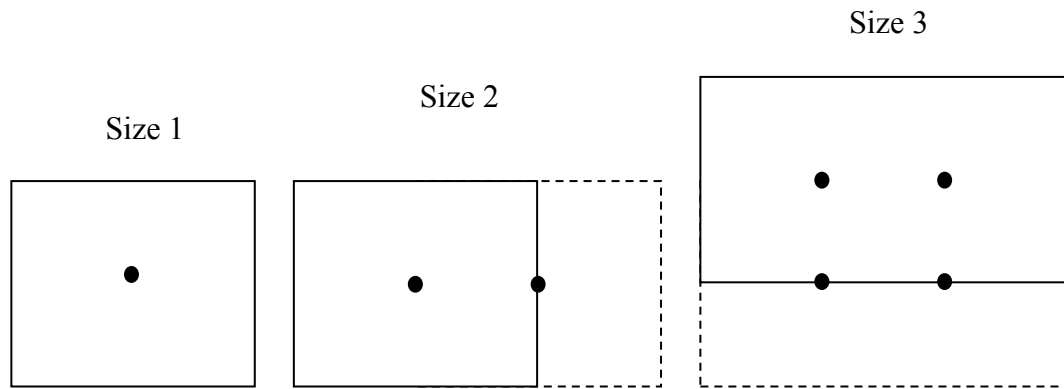

**Figure B.4.1.3.1. Measurement geometry for band I (top) and band II (bottom).**

**Screens larger than 26"**

For screens larger than 26" measurements shall be taken in four directions around the product at 0°, 90°, 180°, 270°. All measurements shall be taken at 0.5 m from the surface of the product.

For products that have a width or height  $\geq 1$  m additional measuring positions for front, rear and sides are required. The width and height of the screen does not include the frame but only the viewable screen area. The amount of positions depends on the size of the screen and is given in horizontal and vertical direction by the width and height in metres of the screen divided by 0.5 rounded to the closest integer. The positions shall be equally divided over the screen surface. See figure B.4.1.3.2.



**Figure B.4.1.3.2. Measurement point on different screen sizes. The dotted lines indicate a screen increase from size 1 by 0.5 m in width and then 0.5 m in height.**

The FPD under test and the measuring probe shall be positioned at least 1 m from all significant metallic structures and objects apart from the test object.

Additional units and connecting cables necessary for the operation of the FPD, which are not part of the test, shall be placed so far away from the measuring setup that the fields they emit do not influence the measurement. Shielding may be added to these units and cables, as long as the 1 m clearance is maintained.

The measuring probe shall be connected to ground. Any eventual cables running between the measuring probe and the measuring instrument shall be positioned in such a way that they do not influence the measured value.

The power cable of the test object shall be connected to the phase and the neutral conductors of the mains power supply. If the mains power supply plug permits an interchange of the live and neutral conductors, measurements shall be taken with the connection that gives the highest reading in band I.

#### **B.4.1.4 Test evaluation**

Results shall be presented as r.m.s. values of the alternating electric field expressed in volt per meter (V/m). For band I, results shall be presented as the measured values at 0.3 m and 0.5 m for normal and stand-by operations if they differ. For band II, the measured values in front of the FPD and the maximum value at rotation shall be presented for normal and stand-by operations if they differ.

If the measured values are less than 10.0 V/m in band I or less than 1.0 V/m in band II the result shall be reported as “< 10.0 V/m” or “<1.0 V/m”, respectively.

If measuring more than one position on the front, rear or sides of the screen the worst-case shall be given in the report.

#### **B.4.1.5 Overall uncertainty**

The test shall be performed in such a way that the total extended uncertainty in the test result will be less than  $\pm (10 \% \text{ of the reading} + 1.5 \text{ V/m})$  for band I and  $\pm (10 \% \text{ of the reading} + 0.1 \text{ V/m})$  for band II.

[Back to A.4.1](#)

## B.4.2 Alternating magnetic fields

### B.4.2.0 Test facility requirements

Background magnetic fields in the test facility, including disturbances transmitted along the power line and internally generated noise in the measuring system, shall together not exceed 40 nT in band I and 5 nT in band II.

### B.4.2.1 Preparation of the FPD for testing

All necessary preparations described in B.0 and B.4.0 shall be done.

### B.4.2.2 Equipment

Alternating magnetic field meter in band I and band II

### B.4.2.3 Method

#### Screens smaller or equal to 26"

The true r.m.s. value of the amplitude of the magnetic flux density vector is measured at 48 points on a cylindrical surface around the test object in the two frequency ranges, band I and band II. The frequency ranges are selected by specified filters in the alternating magnetic field meter.

The measuring geometry is illustrated in Figure B.4.2.3.1. The measurement points are mathematically defined in the following way.

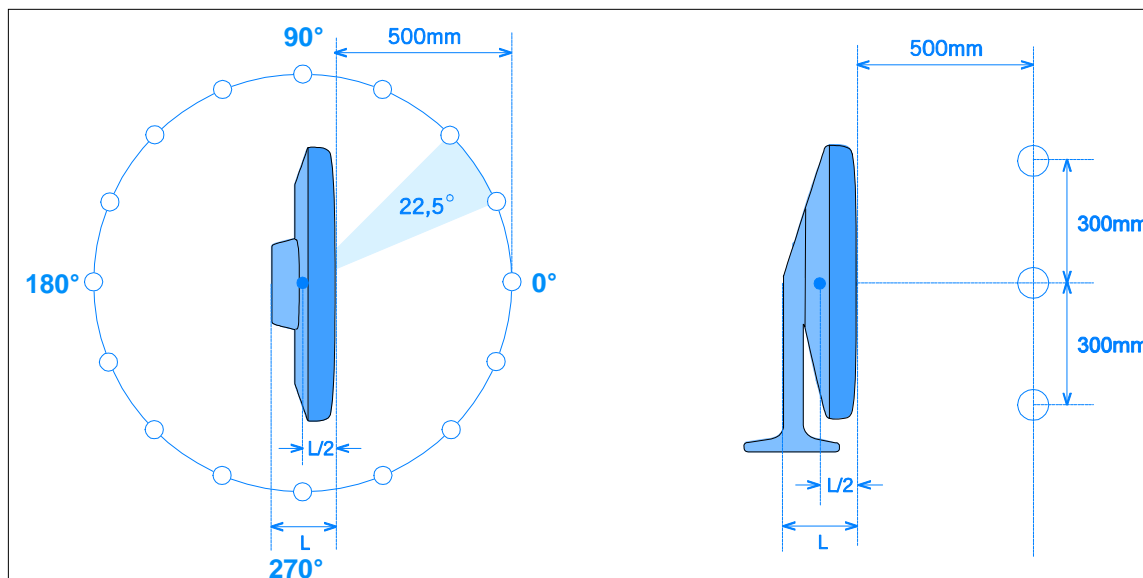

**Figure B.4.2.3.1. Measurement geometry for the test object.**

The FPD shall be positioned such that the tangential plane, to the centre-centre point of the screen surface, is at a right angle to the horizontal plane. The distance between the centre-centre points of the screen surface and the back of the FPD, including an eventual part of a stand holder, along the normal to this tangential plane is called L.

The origin of the cylindrical co-ordinate system is chosen to be situated at a distance  $L/2$  behind the screen surface on the normal to the tangential plane through the centre-centre point. The z-axis is chosen to be at a right angle to the horizontal plane. The angular reference direction is along the above-mentioned normal in the direction pointing outwards from the screen. An angle ( $\vartheta$ ) is positive in the counter-clockwise

direction. The measurement instrument is moving in a counter-clockwise direction around the test sample (as illustrated in the figure B.4.2.3.1). Measurements shall be made at all points which have a minimum clearance of 0.25 m to the outer surface of the FPD and with co-ordinates according to:

$$z = - 0.3 \text{ m, } z = 0 \text{ and } z = + 0.3 \text{ m}$$

$$r = (L/2 + 0.5) \text{ m (at the front also } (L/2 + 0.3) \text{ m in band I)}$$

$$\vartheta = p \cdot 22.5^\circ \text{ where } p \text{ represents all integers in the range } 1 \leq p \leq 15.$$

In case of less than 0.25 m clearance the instrument shall be moved out radial until 0.25 m clearance is achieved.

### **Screens larger than 26"**

For screens larger than 26" measurements shall be taken in four directions around the product at 0°, 90°, 180°, 270°. All measurements shall be taken at 0.5 m from the surface of the product.

For products that have a width or height  $\geq 1$  m additional measuring positions for front, back and sides are required. The width and height of the screen does not include the frame but only the viewable screen area. The amount of positions depends on the size of the screen and is given in horizontal and vertical direction by the width and height in cm of the screen divided by 0.5 rounded to the closest integer. The positions shall be equally divided over the screen surface see figure B.4.1.3.2.

Distances are given in metres and angles in degrees.

The measuring coils shall be stationary during the measurements.

For FPD luminance settings – see General test conditions for emissions.

The power cable of the test object shall be connected to the phase and the neutral conductors of the mains power supply. The FPD does not need to be measured with the phase and neutral interchanged in this case, as the magnetic fields are not influenced by such a change.

#### **B.4.2.4 Test evaluation**

Results shall be presented as r.m.s. values of the magnetic flux density expressed in nanotesla (nT) for the two frequency bands. The values in front of the FPD and the maximum value and its position shall be given both for normal and for standby operation if they differ. If measured values are less than 200 nT in band I or less than 10.0 nT in band II the result shall be reported as "< 200 nT" and "< 10.0 nT" respectively.

#### **B.4.2.5 Overall uncertainty**

The test shall be performed in such a way that the total extended uncertainty in the test result will be less than  $\pm (10 \% \text{ of the reading} + 30 \text{ nT})$  for band I and  $\pm (10 \% \text{ of the reading} + 1.5 \text{ nT})$  for band II.

#### **Note!**

The uncertainties given are worst case limits. In many cases it will be possible to obtain better accuracy, especially in band II.

[Back to A.4.2](#)

## **B.6 Environment**

### **B.6.0 General Clarification**

#### **B.6.0.1 Signatures**

The date of signature shall not be older than 12 months at the time of the application. The templates in the ecological declaration shall be sent either with original signatures or as copies of original documents with original signatures. “Copies” are for example telefaxes or pdf-files of scanned signed documents. TCO Development and/or the responsible test facility may later request the original signed document.

However, copies will not be accepted where the signature has been scanned and pasted into the document.

TCO Development accepts digital signature as an alternative to traditional signature on test reports and declarations submitted as pdf files. To approve a digital signature it is necessary to also submit a digital key to the verifier to facilitate identification.

### **B.6.1 Product description**

The A.6.1 template shall be completed with the requested information about the FPD. This includes the display, panel and when applicable the external power supply.

A type key that includes an Asterisk (\*) for unidentified characters, if any, in the model name and panel identification name shall be submitted to the verifier. Only two \* may be used in the model type key and each \* must include two or more options. For the most up-to-date information about type keys, see the appropriate product Application Process at [www.tcodevelopment.com](http://www.tcodevelopment.com)

[Back to A.6.1](#)

## **B.6.2 Manufacturing**

### **B.6.2.1 Environmental management system certification**

The certificate shall be issued by a certification body that is accredited by an accreditation body covered by the International Accreditation Forum, [www.iaf.nu](http://www.iaf.nu), Multilateral Arrangement on Environmental Management Systems.

The applicant shall submit an ISO 14001 certificate or EMAS registration for every final assembly plant used to manufacture products certified according to TCO Certified.

For applicants submitting several applications, it is sufficient to attach ISO 14001 certificate(s) or EMAS registration(s) with the first application. The certificate(s) or an appendix to the certificate(s) shall show the scope of the certification.

Manufacturing plants that are not yet certified (and that do not fall into the above mentioned category) can seek a 12 months grace period on the first application to obtain ISO14001 certification or EMAS registration. TCO Development reserves the right to deny grace period if the Applicant is considered a high risk for not meeting the 12 month due date. When seeking grace period an agreement must be completed/signed by the Applicant company.

[Back to A.6.2](#)

## **B.6.3 Climate**

### **B.6.3.1 Energy consumption – FPD**

Testing of the product shall be made according to the most recently published version of the Energy Star standard for displays and need only cover the energy consumption requirements of that standard. The product need not be Energy Star certified to be approved for TCO Certified.

Testing is required to be carried out at either test facilities approved by TCO Development or by the U.S. Environmental Protection Agency (EPA). Test facilities shall also be accredited to ISO17025. In both cases the TCO Development approved facility is required to issue a verification report to confirm compliance. In circumstances where the FPD is certified to the most recently published Energy Star standard the TCO Development approved test facility need only verify that the stated energy consumption levels are within required limits, that the EPA test report is genuine and from a lab that is approved by the EPA and accredited according to ISO17025.

#### **B.6.3.1.1 Special conditions**

All exceptions and special requirements, test methods etc. specified by Energy Star are also accepted by TCO Development.

Products that are covered under other Energy Star product specification shall be tested under that specification. Example (displays with integrated TV tuner, displays larger than 60" etc.)

If testing concerns an update of an original certification (additional panel or adapter) that was issued to an older version of an Energy Star standard, then that older version may be used for testing.

### **B.6.3.2 Energy consumption – external power supply**

TCO Development has decided that energy consumption of the external power supply shall follow the EPA demands for compliance with The International Efficiency Protocol requirement for level V, equivalent to the Energy Star version 2.0 for external adapters, also covering battery chargers.

The international efficiency mark consists of a Roman numeral (I – VI) that corresponds to specific minimum Active and No-Load efficiency levels (as well as a power factor requirement for level V) and is printed/applied by the manufacturer on the external power supply marking label.

A test facility approved by TCO Development will require a copy of the display's external power supply marking label where The International Efficiency Protocol requirement for level V symbol is visible as proof of compliance.

[Back to A.6.3.1](#)



## B.6.4 Hazardous substances

### B.6.4.1 Cadmium (Cd), mercury (Hg), lead (Pb) and hexavalent chromium (CrVI)

Exemptions are according to EU Directive 2011/65/EU (RoHS) and the documents supporting the directive except that mercury in lamps is not permitted.

The maximum concentration values tolerated by weight in homogeneous materials for cadmium, mercury, lead and hexavalent chromium are according to EU Directive 2011/65/EU (RoHS) and the documents supporting the directive.

The limit value for batteries is 0.0005 % for mercury, 0.002 % for cadmium and 0.004 % lead per listed part, according to EU Directive 2006/66/EC.

[Back to A.6.4.1](#)

### B.6.4.2 Halogenated substances

**Mandate 1.** The requirement applies to plastic parts in all assemblies and sub-assemblies. LCD panels are included in the requirement.

Exempted are printed wiring board laminates, electronic components and all kinds of cable insulation.

**Mandate 2.** The requirement applies to the whole of the FPD product, including components, parts and raw materials in all assemblies and sub-assemblies e.g. batteries, paint, surface treatment, plastics and electronic components. Printed Wiring Boards are also included in the requirement.

HBCDD has been identified as a Substance of Very High Concern in accordance with EU REACH criteria. The main application of HBCDD in EEE is as a flame retardant in HIPS plastic being used for closures and structural parts of different types of EEE. TCO Development considers that the use of HBCDD in EEE is not deemed essential as technically suitable alternative substances and materials are available and already used extensively today.

Maximum concentration values tolerated for a restricted substance (including decaBDE) is 0.1 % by weight of the material in homogeneous materials.

Fluoroorganic additives, used to modify the dripping behaviour of plastics in fire conditions or to improve the processing behaviour, are exempted provided that they do not exceed 0.5 % by weight of the material in homogeneous material.

[Back to A.6.4.2](#)

### B.6.4.3 Non-halogenated substances

Non-halogenated flame retardants can be used in TCO Certified products once they receive an accepted benchmark. TCO Development makes a list of accepted substances available on its website. The Accepted Substances list is dynamic, which allows new substances that have undergone a valid assessment to be added or for accepted substances to come under reassessment in light of new scientific findings. If an accepted substance is reassessed and given a benchmark score lower than 2 TCO Development reserves the right to remove the substance from the accepted substance list. Any substance to be removed will be set a sunset date. The sunset date shall give adequate time (at least one year) for equipment manufacturers to switch to a flame retardant alternative.

When considered necessary, TCO Development reserves the right to request a substance undergo further assessment in order to assess the completeness, quality and validity of a draft benchmark score, such as a GreenScreen Verification assessment.

Full GreenScreen Assessments of substances are made publicly available on databases such as GreenScreen Store <http://www.greenscreenchemicals.org/gs-assessments/chemicals> or IC2 (Interstate Chemicals Clearinghouse) <http://theic2.org/hazard-assessment> or Techstreet <http://www.techstreet.com/searches/3638231>.

If no public assessment report is available, then TCO Development may place interested persons in contact with the owner of the report.

Table B.6.4.3.1

Benchmark key		
Benchmark 4	Few concerns, i.e. safer chemical	Approved for use
Benchmark 3	Slight concern	Approved for use
Benchmark 2	Moderate concern	Approved for use
Benchmark 1	High concern	Not accepted
Unspecified (U)	Insufficient data to assign a benchmark	Not accepted

#### **B.6.4.3.1 Compliance procedures (See also Flow chart B.6.4.3.1)**

- **First contact your suppliers such as the plastic and panel manufacturer and ask them to confirm that they only use flame retardants including substances on the accepted substance list.**
  
- **If all flame retardants only include substances on the Accepted Substances List the procedure is as follows:**
  1. Sign template A.6.4.3 and submit it to the approved environmental verifier. When the verifier considers all environmental documentation is compliant they will issue an Environmental verification to the applicant.
  
- **If any flame retardant is used that contains a substance that is not on the Accepted Substances List then it will need to be added before approval can be given by the environmental verifier. For this the procedure is as follows:**
  1. Contact TCO Development directly to see if we have any additional information on the substance: Reasons for the substance's absence can be that the substance has received benchmark 1, no assessment has been conducted or it has a benchmark score U (unspecified) due to many data gaps.
  2. If TCO Development requires the substance to be benchmarked, we recommend you contact your supplier and inform them that the substance will need a GreenScreen assessment by a licensed profiler. The list of licensed profilers can be found on the Clean Production Action website at <http://www.greenscreenchemicals.org/professionals/profilers>
  3. A draft report per substance (not flame retardant) is assembled from the available information (literature search, structural similarity comparison, expert judgment) by the profiler.
  4. It is the profiler that sets the benchmark score per relevant substance, which is valid for 3 years. Substances are assessed at 3 year intervals since mandates are revised and more data and new knowledge on the substance may lead to other results.  
**Note:** All assessments and reassessments shall be conducted by licensed profilers.
  5. Full GreenScreen assessments per substance shall be submitted to TCO Development for final approval before the Accepted Substances List can be updated.
  6. Once a substance is added to the list and the verifier identifies them, then they will issue the environmental verification to the applicant (see above point 1 under: "If all flame retardants only include substances on the Accepted Substances List the procedure is as follows")

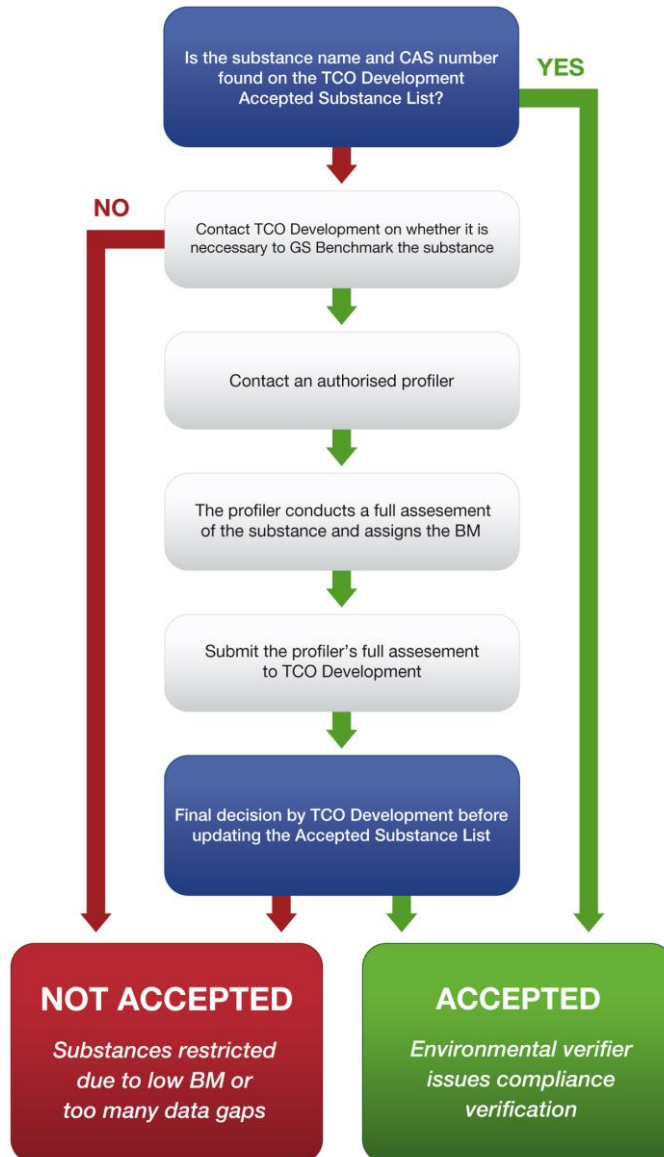

Flow chart B.6.4.3.1. The Compliance procedure

**B.6.4.3.2 Grace period**

Applicants signing mandate A.6.4.3 have the option to seek a grace period in order to give them time to assess flame retardants used and substitute these if necessary. The request for a grace period shall be sent to TCO Development together with a description on why a grace period is necessary and a timeline for the GreenScreen assessment and/or substitution. On receiving this request, TCO Development will conduct a risk assessment as to whether the applicant can be given a grace period to show compliance. If a grace period is not granted, then the applicant is required to ensure that all used non-halogenated flame retardants only include substances that are on the TCO Accepted Substances list before a certificate can be issued to them. After the grace period, if an approved a grace period exceeds the due date, then the verifier shall contact TCO Development and a course of action will be decided after talking first with the applicant.

**Back to A.6.4.3**

#### **B.6.4.5 Phthalates**

Maximum concentration values tolerated for a restricted substance is 0.1 % by weight of any plasticised homogenous material.

[Back to A.6.4.5](#)

#### **B.6.4.6 Hazardous substances in product packaging**

Limit values are according to Directive 94/62/EC on packaging and packaging waste.

[Back to A.6.4.6](#)

### **B.6.5 Material Resource Efficiency**

#### **B.6.5.1 Lifetime extension**

That spare parts shall be available for three years from “the time that production ceases” is only applicable to the production of the specific FPD, certified by the brand owner according to TCO Certified.

Regarding spare parts:

- If a part of a product is broken (e.g. bezel, stand) the end user shall not need to replace the whole product, only the broken part. The broken part shall be possible to replace with an equivalent part (this part does not have to be identical to the broken part).
- When the cost for replacing a broken part (e.g. panel) exceeds the cost of replacing the whole product, then that part need not be considered as a spare part under this mandate.

[Back to A.6.5.1](#)

#### **B.6.6 End of life**

##### **B.6.6.1 Material coding of plastics**

If the amount of flame retardant exceeds 1 % by weight the coding shall be complemented in accordance with ISO 1043-4.

The requirements also apply to plastics in the LCD panel, however labelling of the light guide may instead consist of the application of a label in close proximity, for example PLASTIC LIGHT GUIDE:>plastic type(s)< or >PLASTIC LIGHT GUIDE:plastic type(s)<. Labelling of Plate diffuser (not thin plastic film diffuser) shall follow the same rules as for the light guide.

The requirement does not cover other thin plastic films in the panel due to difficulties in labelling these.

[Back to A.6.6.1](#)

### **B.6.6.2 Take back system**

Tick the box of the option chosen.

If the applicant chooses **option 1** (*Product only sold on markets with WEEE legislation or similar*) and signs the declaration, the requirement is fulfilled.

If **option 2 or 3** (*World-wide product take back or One additional market lacking WEEE legislation where product take back is offered*) is chosen, the declaration must be signed and the applicant must provide a short description of how the take-back system on that market works. This can also be done by giving a reference (for example a link to a website) to the representative, associated company or affiliate taking care of the take-back system on that market.

In case of option 3 the applicant must also provide the name of the market (country) where a take back system is provided.

TCO Development has no requirement on the take-back system being free of charge.

It is important to point out that any recycling and waste export control legislation in countries where the applicant company operates must always be met.

[Back to A.6.6.2](#)

## **B.7 Socially Responsible Manufacturing**

### **B.7.1 Socially Responsible Manufacturing**

#### **B.7.1.1 General Clarifications**

The mandate is a social performance mandate and criteria are based on the eight ILO (International Labour Organization) core conventions and local legislation. The mandate stipulates the minimum standards for Code of Conduct, Inspection and Corrective Action engagement of the brand owners regarding the situation at their own and/or their supplier's manufacturing facilities of TCO Certified products.

#### **B.7.1.2 Background information**

##### **B.7.1.2.1 SA8000**

SA8000 is based on the UN Universal Declaration of Human Rights, Convention on the Rights of the Child and various International Labour Organization (ILO) conventions. SA8000 is a global social accountability standard for decent working conditions, developed and overseen by Social Accountability International (SAI). SAI contracts with a global accreditation agency, Social Accountability Accreditation Services (SAAS) that licences and oversees auditing organisations to award certification to employers that comply with SA8000.  
For more information visit: <http://www.sa-intl.org/>

##### **B.7.1.2.2 Electronic Industry Citizenship Coalition (EICC)**

The Electronic Industry Citizenship Coalition (EICC) is a group of companies working together to create a comprehensive set of tools and methods that support credible implementation of the Electronic Industry Code of Conduct. The EICC Code of Conduct is at the core of member requirements and members are required to commit to it, spread that commitment to their supply chains and undertake a range of assessment activities to ensure they are accountable to their commitment to the Code.

The EICC VAP (Validated Audit Process) is a factory audit framework for identifying risks and driving improvements and robust management systems for labour, ethics, health, safety and environmental conditions in the supply chain. It is a third party validated audit service that provides an independent audit of a supplier, potential supplier, and/or a company's own facilities.

For more information visit: <http://www.eicc.info/>

##### **B.7.1.2.3 Grace Period.**

Brand owners signing mandate A.7.1 for the first time have the option to seek a 12 month grace period in order to give them time to improve their supply chain management systems. On receiving this request, TCO Development will conduct a risk assessment as to whether the brand can be given a grace of 12 months to show compliance. If a grace period is not granted, then the brand is required to make all required improvements and actions before a certificate can be issued to them. After 12 months, if an approved a grace period exceeds the due date, then the verifier shall contact TCO Development and a course of action will be decided after talking first with the brand owner.

### **B.7.1.3 The verification process**

#### **B.7.1.3.1 Proof documentation to be submitted to a Social Reviewer approved by TCO Development**

1. Submitting the code of conduct

The Brand owner shall submit a copy of their code of conduct signed (on the document copy or declaration of identity) by the SMR (or higher ranking member of the company) to an approved Social Reviewer. If the Code of conduct has not changed since last time it was reviewed the brand does not have to send it again. In this instance the SMR shall declare this.

**SA8000:** If the brand owners head office is certified according to SA8000 then the code of conduct does not have to be reviewed by the Social Reviewer. It is enough to send a copy of the SA8000 certificate to the Environmental Verifier and the Code of conduct with the application to TCO Development.

2. Submitting the proof of the supply chain being informed of the code of conduct.

The Brand owner shall submit a description on how their first tier manufacturing facilities of TCO Certified products are informed of their code of conduct for review by an approved Social Reviewer.

**SA8000:** If the brand owners head office is certified according to SA8000 then a description does not have to be reviewed by an approved Social Reviewer. It is enough to send a copy of the SA8000 certificate to the Environmental Verifier and the description with the application to TCO Development.

3. Submitting the annual factory list

The Brand owner shall submit an annual list of all first tier manufacturing facilities of TCO Certified products to the Environmental Verifier and TCO Development. The list shall show the factory name, address, date of conducted audit, date of planned audit and type of audit. Each factory shall have an audit date assigned to it. All these audits may be first, second or third party audits (at least one of the audits shall be 3<sup>rd</sup> party and have been conducted within 12 months from the date the list is submitted). The list shall show that all factories have or will be audited once over a 3 year period.

4. Submitting the annual third party audit report

The Brand owner must submit one annual third party audit report carried-out at a first tier manufacturing facility of TCO Certified products for review by an approved Social Reviewer. The audit report shall at least cover the criteria in A.7.1 of TCO Certified and be of equal quality as an EICC audit. When possible the audit report shall be from a different first tier manufacturing facility than the previous years unless otherwise specified by TCO Development.

**SA8000:** If the first tier manufacturing facility is certified according to SA8000 then the third party audit report does not have to be reviewed by an approved Social Reviewer. It is enough to send a copy of the SA8000 certificate to the Environmental Verifier and a copy of the audit report with the application to TCO Development.



5. Submitting the annual corrective action plan (CAP) if relevant.

The Brand owner must submit one corrective action plan (CAP) for review for any non-conformity found in the submitted audit report to an approved Social Reviewer.

**SA8000:** If the first tier manufacturing facility is certified according to SA8000 then the CAP does not have to be reviewed by an approved Social Reviewer. It is enough to send a copy of the SA8000 certificate to the Environmental Verifier and a copy of the CAP with the application to TCO Development.

**B.7.1.3.2 On-site inspection initiated by the Brand owner (Social revision)**

In accordance with the compliance options under A.7.1 the Brand owner shall provide a third party conducted social audit and a CAP for any non-conformities carried out at one of their first tier facilities producing TCO Certified products.

The following applies:

- The Brand owner may choose the third party Audit firm.
- Third party auditors used by the Brand owner to carry-out the factory inspection and issue the report shall have documented experience of carrying out social auditing. The auditor should have undergone the SA8000 Advanced Auditor Training or an equivalent training course
- A third party is considered to be a person or body that is recognised as being independent of the parties involved, as concerns the issue in question. Parties involved are normally the Brand owner (first party) and purchaser (second party).

**B.7.1.3.3 Review of the proof documents**

The approved Social Reviewer will evaluate the documents according to the following principles.

- **Code of conduct:**
  - The code of conduct shall be considered consistent with the ILO:s eight Core Conventions, art 32 in UN:s Convention on the Rights of the Child, the health and safety legislation in force in the country of manufacture, and the labor law, including rules on minimum wage and the social security protection in the manufacturing country
  - The contents of the code of conduct shall have been adopted by the Board and addressed by management.
  - The code of conduct shall relate to the manufacturing of the specific product being certified.
- **Supply chain being informed of the code of conduct:**
  - Examples may be that the Brand Owner has translated the Code of Conduct into local languages. This shows that the company has made efforts so that management and employees are able to be informed about the code's content in their own language.
  - Or the company has conducted training on the Code for employees and/or management at production facilities.
  - Another common way to inform production facilities can be to have them fill out a questionnaire (self-assessment) on compliance with the code.

- **Audit report reviews:** Central to the compliance options is the review of the factory audit report conducted by a third party Social Reviewer approved by TCO Development. Audit reports sent for review shall not be older than 12 months. It shall be authentic, conducted by an auditor with the correct competence and cover the relevant manufacturing site.
- **Corrective Action Plan (CAP):** If there were findings during the factory inspection then a CAP (remedial plan plus timelines and evidences) for the findings shall be submitted for review together with the audit report. This CAP will be evaluated for effectiveness by the Social Reviewer. A judgement on the remedial effectiveness and a summary will be given in the Verification Report issued by the Social Reviewer.
- **The approved Social Reviewer:** All supporting documentation shall be reviewed by a third party approved by TCO Development. This reviewer shall not be the same person that conducted the factory audit. The reviewer has the authority to review and verify the following types of documents:
  - Code of conducts
  - Communication of the code of conduct
  - Audit reports,
  - CAPs,
  - SA8000 certificates/audits
  - Supporting documentation

After the review the Social Reviewer issues the Audit Report Verification document to the Brand owner or the applicant. It is the final responsibility of the Brand owner to submit this document to TCO Development to show that they are aware of the situation at the factory and accept the report.

A verification report issued by the approved Social Reviewer is valid for 12 months from the date of the Brand owner's first issued TCO Certified certificate covering mandate A.7.1. The verification must be updated annually. The list of approved Social Reviewers is found at: [www.tcodevelopment.com](http://www.tcodevelopment.com)

#### **B.7.1.3.4 On-site inspection initiated by TCO Development (Spot-checks)**

TCO Development reserves the right to require full audit reports and conduct or commission on-site inspections at first tier manufacturing facilities to verify that the Brand owner is fulfilling the obligations according to this mandate. The planning of social audits will be done in cooperation with the Senior Management Representative appointed by the Brand owner. Audits will be implemented by TCO Developments partner organisation for the actual geographic region. Social audits initiated by TCO Development will be realized on a judgement sample basis, in each case decided by and financed by TCO Development. Results from the audits will be shared with audited factory (both management and worker representatives) and all the brand owners listed as using the audited factory in order to create a combined effort toward implementing the CAP. For TCO Development, the spot-checks and all other submitted reports contain valuable information on social performance, making it possible to translate findings into metrics and then measure improvement through code of conduct and audit methodology.

[Back to A.7.1](#)

## **B.7.2 Senior Management Representative**

### **B.7.2.1 General Clarifications**

The mandate underlines the importance for the Brand owner to appoint a senior management representative who, irrespective of other responsibilities, has the authority to ensure that the requirements of this mandate are met. This aims to create an open and transparent dialogue between TCO Development and top management at the brand owner company.

### **B.7.2.2 SMR review**

The intention of the review of the SMR is to ensure that the SMR has the necessary authority and is working in a structured way in implementing the Brand owner's code of conduct. The SMR may bring assistants to the review meeting if needed.

The following questions will be asked of the SMR:

1. The SMR will be asked questions on how the communication of the Brand owner's code of conduct to first tier factories has been done. (See point 1 of the self-assessment questionnaire)
2. The SMR will be asked questions about the Brand owner's audit schedule and about some of the audits that have been done. (These reports may be first, second or third party audits).
3. The SMR will be asked to show examples of progress for some corrective action plans.
4. The SMR will be asked to fill in the self-assessment questionnaire on proactive work (point 2-19) by TCO Development (B.7.2.2.1) prior to the review and explain in more detail the Brand owner's proactive work to implement their code of conduct during the review. The SMR might be asked to show supporting documentation for this. The self-assessment questionnaire does not have to be reviewed by a verifier approved by TCO Development. It is sent directly to TCO Development prior to the SMR review.

The Questionnaire and Guidelines for the assessment are public and can be downloaded at: [www.tcodevelopment.com](http://www.tcodevelopment.com)

As long as the SMR is able to show the relevant documents and explain the Brand owner's structured work to implement their code of conduct the review is accepted. If the SMR is not able to get hold of necessary documents or if he/she cannot explain about the Brand owner's structured work to implement their code of conduct the review is not accepted.

The review may be done through an online meeting. However, it is necessary that documents can be shared (during or prior to the meeting) and that the communication quality is adequate for full understanding.

If it is not possible to set up an online meeting that fulfils the requirements above or if the review does not give an acceptable result then TCO Development has the right to require the SMR to be reviewed by a third party auditor paid by the brand owner. The report from this review is then sent to TCO Development.

TCO Development also has the right to require a face to face review of the SMR. For this type of review, TCO Development will cover their own costs.

#### **B.7.2.2.1 Self-assessment questionnaire on proactive work**

The self-assessment questionnaire is provided by TCO Development and is a set of questions covering such areas as the implementation of the Brand owner's code of conduct, auditing and follow-up of social criteria, trade union rights and representation, activities to avoid discrimination and create an open dialogue with suppliers.

The Brand owner SMR is responsible for answering all questions and providing documented proof of how it supports its suppliers in these areas. Each answer is colour graded full- (Green), partial- (Yellow) or non- (Red) compliance level.

In order to highlight the need for progressive improvement and level the commitment between different brands, the questionnaire is required to be submitted annually during the SMR review. However, the self-assessment questionnaire does not have to be reviewed by a verifier approved by TCO Development. It is sent directly to TCO Development prior to the SMR review.

There is currently no minimum level required for the proactive work reported in the questionnaire (point 2-19) in this generation of TCO Certified. The data collected in the questionnaire on proactive work will be used to risk assess Brand owners for the spot-check program. In this program TCO Development make annual third party factory audits according to the code of conduct on a number of Brand owners first tier factories. The questionnaire is also intended to measure the progress in the industry and to be used as a basis for future criteria development in this area.

The Questionnaire and Guidelines for the assessment are public and can be downloaded at: [www.tcodevelopment.com](http://www.tcodevelopment.com)

[Back to A.7.2](#)

## **B.7.3 Conflict minerals**

### **B.7.3.1 General Clarifications**

The mandate mainly focuses on the 3T+G minerals which are being mined within the Democratic Republic of Congo (DRC) region and used in a wide range of computer products. Once refined the origins of minerals are hard to trace, therefore we are recommending the importance of participation with legitimate in-region initiatives that directly benefit people in the conflict-affected regions. However, since the number of participants for in-region initiatives are low at this stage we also accept involvement in smelter/refinery certification programs since they complement in-region initiatives. Also we approve brands that can satisfactorily provide proof that they have adopted the *OECD Due diligence guidance*, since it provides a framework for brands to ensure that they respect human rights and do not directly or indirectly contribute to conflict.

### **B.7.3.2 Background information about the initiatives**

TCO Development is demanding brands address the conflict mineral concerns of the private and public sector while delivering solutions that benefit those involved in the responsible minerals trade in the DRC. TCO Development considers participation in the following initiatives facilitates that goal. It is TCO Development's opinion that the OECD Due Diligence Guidance for Responsible Supply Chain of Conflict-Affected or High-risk Areas is the most ambitious approach in the list.

- *The OECD Due Diligence Guidance for Responsible Supply Chains of Minerals from Conflict-Affected and High-Risk Areas* (“the Guidance”) <http://www.oecd.org/corporate/mne/mining.htm>. Brands require suppliers to disclose their sourcing origins of conflict minerals by using a questionnaire template such as the EICC ‘Conflict Minerals Reporting Template’ or similar in order to prevent the potential use of conflict minerals.
- *iTSCi* - ITRI represent tin producers and smelters. This program is a supply chain initiative to verify and trace minerals from the mine to smelter (traceability tagging). Although full membership is focused on upstream companies (Mining, Smelters etc) an Associate membership for downstream companies exists (manufacturers etc). Associate members contribute to the financing of the iTSCi program and so keep informed of initiative activities, specific mining sites whilst they support development in Africa.

***For more information:***

[https://www.itri.co.uk/index.php?option=com\\_zoo&view=item&Itemid=191](https://www.itri.co.uk/index.php?option=com_zoo&view=item&Itemid=191)

- *Conflict-free Tin Initiative* (CFTI); sources conflict-free tin from the South Kivu province of DRC that implements the ITRI Tin Supply Chain Initiative (iTSCi) the due diligence and traceability system
- *The Public-Private Alliance for Responsible Minerals Trade* (PPA) is a multi-sector and multi-stakeholder initiative that provides funding and support to systems that trace and certify mineral supply chains in the DRC and Great Lakes Region. <http://www.resolv.org/site-ppa/>

- Other relevant in-region initiative. Initiatives not given in the list but prove active commitment to an initiative that aims at increasing legitimately sourced minerals.

Examples of other relevant initiatives that are approved:

- *Solutions for Hope (SfH)*; sources conflict-free tantalum from the Katanga province of DRC (incorporates the iTSCi process and CFS program).
  - *The Certified Trading Chains* initiative (CTC) is a program supported by the German government and certifies mines to defined performance standards
- Member of the EICC & GeSi *Conflict-Free Sourcing Initiative (CFSI)*. Members contribute to a number of tools and resources including the Conflict Minerals Reporting Template; supporting in-region sourcing schemes and the Conflict Free Smelter Program (identification of Smelters and Refiners that source conflict-free minerals).

### **B.7.3.3 The verification process**

At least one of the options in the mandate box shall be marked. Every initiative the Brand is a participant in shall be provided. The following shall occur before the verifier may issue a verification of compliance.

- The template shall be completed by the responsible person at the brand owner company.
- The brand shall complete the TCO Certified Conflict Mineral Questionnaire and submit it and any required supporting documents for review. The verifier then assesses compliance and issues the verification report.

#### **Supporting documents**

- If the brand has a management system covering conflict minerals within its supply chain which it states are based on the OECD Due Diligence guidelines, then a supporting document that outlines those due diligence measures shall be submitted. Example of proof are:
  - Due Diligence Roadmap, Sustainability report or Conflict Mineral Report asserting the OECD five step framework.
  - Link to where information/findings are posted on the brand's website.
- The brand shall provide a copy of its conflict mineral policy and state where the information is made public.
- If the brand is part of an in-region initiative or the EICC CFSI, then supporting documents or links to relevant websites shall be provided to the approved verifier in order for them to verify participation.
- If the brand marks the option 'Other relevant initiative', then the name of the initiative shall be entered into the template and information on the initiative (or website) shall be submitted to the verifier and they will contact TCO Development in order to make a joint assessment before it can be accepted as an option. Although unlikely, any additional review fee entailed for an extra assessment will be charged to the applicant, after receiving the applicant's consent.
- When the application is satisfactory, the verifier notes on the verification report the fulfilled options and the type of supporting documentation.

[Back to A.7.3](#)