

LANDTEC THERMAL GAS MASS FLOW METER

Operations and Instruction Manual

For ACCU-FLO Models LIA and LRA



Make the Wise Choice.
Choose LANDTEC ACCU-FLO Meters.



LANDTEC
850 South Via Lata, Suite 112
Colton, CA 92324
Tel (800) 821-0496
Fax (909) 825-0591
www.landtecna.com

Table of Contents

Introduction	Welcome	5
SECTION A	Unpacking Your LANDTEC Meter	9
Getting Started	Maintenance	9
	Calibration	9
	Installation and Mounting	10
	Locating Proper Wiring Diagram	10
	Insertion Flow Meter Application	11
	LANDTEC Valve Assembly Operation	11
	Compression Fitting Operation	12
	Installation Instructions	12
	Captive Flow Conditioners	13
	Probe Insertion Guideline Drawing	14
	Installation Depth Chart	15
	Large Duct or Stack Applications	16
	In-line Flow Meter Application	17
	Terminal Hookup ACCU-FLO Integral (Series LIA)	18
	24 VDC ACCU-FLO Integral Terminals Series LIA	19
	AC Powered ACCU-FLO and DC Powered ACCU-FLO	
	Integral Terminals (Series LIA)	20
	Terminal Hookup ACCU-FLO Remote (Series LRA)	21
	24 VDC ACCU-FLO Remote Terminals (Series LRA)	22
	AC Powered ACCU-FLO and DC Powered ACCU-FLO	
	Remote Series Terminals (Series LRA)	23
	Junction Box Wiring Terminals for Remote Style Meters	24
SECTION B	Principle of Operation	27
Specifications	Features and Benefits	28
	LANDTEC ACCU-FLO Styles & Specifications	29
	LANDTEC ACCU-FLO Organic (OLED) Display	30
	Approvals	31
SECTION C	LIA Series Integral Style Flow Meters	35
Drawings	LRA Series Remote Style Flow Meters	36
	Remote Bracket Layout	37
	Mounting Hardware:	
	SVA05 Series Isolation Valve Assembly for Insertion Meters	38
	STCF Series Teflon Ferrule Compression Fitting	38
	SVA05 Series Isolation Valve Assembly Detail	38
	Mounting Plate for Thin Walled Ducts	38

continued on next page

SECTION C	SVA05LP Low Pressure Isolation Valve Assembly	39
Drawings	In-Line and Insertion Flanges	40
SECTION D	Common Diagnostics	43
Diagnostics	In-Situ Calibration Check	45
SECTION E	Limited Warranty	49
Warranties and Service Work	Cancellation/Return Policy	49
	Returning Your LANDTEC Flow Meter	51
	Return Material Authorization Form	52
SECTION F	Modbus Register Listing	55
Modbus	Modbus Protocol & Function Codes	56
	LANDTEC Register Output Format	59
	LANDTEC Addresser Software	59
	LANDTEC Addresser Typical Printout (Version 3.14)	60
SECTION G	LANDTEC ACCU-FLO™ Field Programmable “Dongle”	64
Appendix	Correction Factors For Varying Gas Mixes	65
	Installations Where Pipe Condensation May Develop	65
	J-Box and Upstream Orientation	66
	What Is a Thermal Mass Flow Meter?	67

Welcome

We are pleased that you have purchased a LANDTEC Mass Flow Meter for your requirement. We hope that you are satisfied with the performance, operation and design of our highly precise, NIST traceable Thermal Gas Mass Flow Meter.

LANDTEC is your source for monitoring, measuring and controlling the gas mass flow in your industrial process, building management system or environmental application. Our high performance, NIST Traceable, Thermal Mass Flow Meters will help increase productivity, reduce energy costs, maximize product yields, and/ or help reduce environmental insult. LANDTEC provides high quality In-Line and Insertion Thermal Mass Flow Meters for a wide variety of industrial, commercial, and environmental monitoring needs, including carbon credit verification for Greenhouse Gas reduction.

LANDTEC Flow Meters measure mass flow directly — there is no need for ancillary instrumentation such as temperature or pressure transmitters. Furthermore, our instruments have exceptional signal sensitivity, have no moving parts, require little if any maintenance, have negligible pressure drop and have a turndown up to 100 to 1, and resolve as much as 1000 to 1. LANDTEC Flow Meters can measure the mass flow rate and consumption of air, oxygen, natural gas, nitrogen, digester gas, biogas, flare gas, hydrogen, argon, carbon dioxide and other gases and gas mixes.

The ACCU-FLO Meter is the latest addition to our family of high performance Thermal Mass Flow Meters. It features a bright graphical display of Flow Rate, Total and Temperature, robust industrial enclosure, and easy to access power and output terminals. LANDTEC ACCU-FLO meter has a dual-compartment windowed enclosure featuring a very high contrast photo-emissive OLED display with a new photocell activated Screen Saver. The rear compartment, which is separated from the electronics, has large, easy to access and well marked terminals, for ease of customer wiring. It is powered by 24 VDC (12 VDC optional, or 115/230 VAC). The power dissipation is under 2.5 watts (e.g. under 100 ma at 24 VDC for the DC version.)

Please let us know if we can assist you in any way with your LANDTEC Flow Meter, or if you have any questions about its installation, operation, or features. Simply phone us at 800-LANDTEC, or visit our website at WWW.LANDTECNA.COM.

Section

A

GETTING STARTED

Getting Started

UNPACKING YOUR LANDTEC METER

Your LANDTEC flow meter is a sensitive, yet rugged, precision built electronic instrument. Upon delivery, care should be taken when opening the shipping container and removing your meter. The meter should be inspected for any damage that may have occurred during transit. If damage is found, please contact the carrier immediately to place a claim for damaged goods. The contents of the container should be checked against the packing list for any discrepancies. If there are any questions as to the contents or configuration of the equipment including calibration ranges, or, mounting hardware, contact LANDTEC as soon as possible. Please save shipping container and packaging materials (including PVC tube probe protector on LANDTEC Insertion Flow Meters) in case the unit needs to be returned for any reason.

MAINTENANCE

LANDTEC thermal mass flow meters essentially require little or no maintenance. While the sensing element is somewhat resistant to dirt and particulate build up, it may become necessary to clean it from time to time if mounted in extremely dirty environments. **NOTE: ALWAYS REMOVE THE POWER PRIOR TO ANY CLEANING OR MAINTENANCE.** A detergent or appropriate non-corrosive solvent for removing the buildup may be required. A soft brush can be used to gently clean the sensing element's surface, using caution

to avoid damaging the sensor elements (the RTDs). If any disassembly is necessary, contact LANDTEC for instructions. In general, it is recommended that your LANDTEC Thermal Mass Flow Meter be returned to the factory if cleaning, repair, or recalibration is needed. This is usually the most cost-effective and reliable alternative.

CALIBRATION

LANDTEC ACCU-FLO Meter has continuous diagnostics. The raw calibration milliwatts (mw) is always displayed in the upper left hand corner of the meter's display. At any time, you can check this reading at a "no flow" condition and compare the reading to the original reported "zero flow" value noted on the last few lines of your meter's Certificate of Conformance or the flow meter's data tag. This diagnostic procedure not only checks the sensor performance and the "live zero" calibration point, but it verifies that the sensor is clean. It essentially provides a means to validate the meter's performance, verifies that there is no shift or drift, and eliminates the need for annual factory calibrations. This simple field diagnostic procedure also verifies that the sensor is free from contamination, even without inspection. See "In-Situ Calibration Check" on page 46.

- ! **CAUTION cable glands shipped with unit are for shipping purposes only.**
 - **Remove shipping cable glands before installing.**

- ! **CAUTION If installing in a Class I hazardous location the installation must comply with appropriate electrical codes.**

- ! **CAUTION Installer must supply proper ground and bond wire for the transmitter and the sensor per appropriate electrical codes**

INSTALLATION AND MOUNTING

- Check the Certificate of Conformance included with your LANDTEC Thermal Mass Flow Meter for system pressure, temperature, gas composition, power input, and signal output.
- It is recommended that the flow meter be inserted in a location of maximum straight run. It is suggested that there be a minimum of 15 pipe diameters of straight run upstream, and 5 diameters downstream, depending on the conditions. See chart on page 11. Note, obstructions such as valves, blowers, expanders and PVC and HDPE pipes will require additional straight run (contact factory for assistance).
- Check the orientation¹: Standard calibration flow direction is left to right when facing the flow meter. Gas flow direction is marked with an arrow on in-line flow meters; UPSTREAM is marked on insertion probes.
- Do not rotate probe¹, or errors may occur. If enclosure is facing incorrectly, rotate the enclosure 180°, but do not rotate the probe. The UPSTREAM mark still needs to be facing Upstream.
- Hook up the system per the wiring diagram provided with your LANDTEC flow meter (see inside of rear compartment cover for terminal designation). Double check that wiring for the proper power and signal connections are correct.
- Check that all plumbing and electrical hook-ups are in accordance with OSHA, NFPA, and all other safety requirements.
- **For Remote Style Meters (LRA) be sure the Remote Electronics is matched with the Transmitter's Junction Box and its attached Probe or Flow Body. There will be Metal Serial Number Tags on both the Transmitter as well as the Remote Electronics enclosure. Do not mismatch the serial numbers of the Remote Electronics and the Junction Box, or calibration errors will occur.**

LOCATING PROPER WIRING DIAGRAM

- 1) Look at the sticker on your meter. The first three digits describe the basic model that you have. Refer to the appropriate page numbers below for your wiring diagram
- 2) LIA: see page 19
- 3) LRA: see page 22 for input/output terminals; see page 24 (Junction Box Wiring Terminals for Remote Style Meters)

WIRING

Follow the instructions below to remove the rear cap for wiring. CAUTION: Do not open the display side!

Before removing the rear cap to access the wiring terminals it is essential to completely remove the screw assembly on the side of the rear enclosure to free up the threads so the lid can be removed. Note there is a Red Tag attached to the screw assembly stating **"Remove Screw Before Opening Lid"**. After the wiring is completed (see pages 18 to 23 for wiring details), please close the lid, and reinsert the screw assembly in the same manner.

Note: See "Approvals" page for Hazardous Location Approvals (DC Powered Meters Only)

¹ The Integral Style of LANDTEC ACCU-FLO Insertion Meters have the Display oriented as shown on page 14. If an alternate orientation of the display, or enclosure is required (ie. installation into a vertical pipe), please furnish a sketch or drawing, and specify "ROTATE" on purchase order. However, if it is later determined that the enclosure needs to be rotated, that procedure can be done in the field. However, if the display needs to be rotated, then the meter must be sent back to LANDTEC to be modified. Do not attempt this in the field. An RMA will be required prior to returning the meter (see page 51). The procedure for rotating the enclosure is as follows: Clamp the enclosure of the ACCU-FLO in a vise with the probe pointing up to the ceiling. Then take a 7/8 wrench and turn the probe to the proper orientation. Lock the probe into its new position with a set screw (not provided).

Insertion Flow Meter Application

FLOW PROFILE AND INSTALLATION CONSIDERATIONS

Insertion Flow Meters, although generally easier to install than In-Line Flow Meters, require proper installation, and a well developed flow profile, in order to perform properly. Please refer to the section on the following pages titled PROBE INSERTION GUIDELINE DRAWING (page 14) and INSTALLATION DEPTH CHART (page 15).

LANDTEC VALVE ASSEMBLY OPERATION

Valve assemblies (SVA05 and SVA05LP) are an optional mounting hardware for Insertion Style Flow Meters (see pages 38 and 39). They allow the removal of insertion-style meters for service, cleaning, recalibration, relocation, etc. without the need to “shut-down” your process. The probe insertion depth is adjustable to permit sensor to be located at center to optimize measurement accuracy. (Refer to PROBE INSERTION GUIDELINE DRAWING and CHART, pages 14 & 15.) The ball valve will seal off leaks of the process gas at the point of insertion after the probe assembly has been removed. The assembly includes a valve, threadolet, compression fitting with Teflon ferrule, a cable restraint, and two collar clamps.

A threaded half coupling (3/4" FNPT) properly sized to accommodate the isolation valve retractor assembly must be fitted to the pipe/duct to which the insertion probe will be inserted. Avoid T-Fittings since they will disturb the flow profile, and effectively reduce the measurement area. Direct

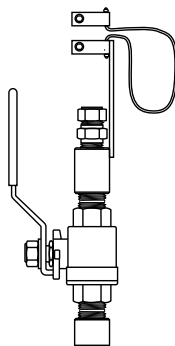

NOTE:
Detailed Drawings are shown on pages 38 & 39.

threading together (or with necessary bushings) of the retractor assembly may be required. In other cases, the threadolet must be welded in place and a clearance hole must be drilled through the pipe/ duct to accept the probe assembly. **If the pipe/duct is under pressure during installation, a hot tap drill (not available through LANDTEC) may be required.**

FLOW CONDITIONING AND STRAIGHT RUN

Although a minimum of 15 pipe diameters of upstream straight run is commonly recommended, to absolutely assure that the flow profile is well developed at the point of measurement, either use Flow Conditioners (standard in LANDTEC In-Line Flow Meters, 1/2" and larger, and also available as assemblies for Insertion Flow Meters, see page 13), or consider additional straight run. The Chart below provides examples of the amount of straight run that would virtually assure that there are no flow disturbances at the point of measurement.

IMPORTANCE OF FLOW CONDITIONING Recommended Pipe Diameters Upstream		
DISTURBANCE	WITHOUT FLOW CONDITIONING	WITH FLOW CONDITIONING ¹
	Minimum Industry Recommendation	LANDTEC Recommendation
One 90° Elbow	15	3
Two 90° Elbows in the same plane	20	5
Two 90° Elbows in different planes	At least 40	9
4:1 Area Reduction	15	3
4:1 Area Expansion	At least 30	10
Multiple Disturbance	To Be Determined	TBD

¹ This column applies to In-Line Flow Meters, which come standard with built-in Flow Conditioners, as well as Insertion Meters, when provided with upstream Captive Flow Conditioners (see page 13).

COMPRESSION FITTING OPERATION

A bored through tube fitting, properly sized to accommodate an insertion probe's particular OD, can be provided by the user or purchased as an option from LANDTEC (see page 38). Prior to installation, a clearance hole to accommodate the insertion probe assembly must be drilled in the pipe/duct. A fitting (1/2" FNPT) is then welded in place or threaded into the half-threadolet which has been welded to the pipe/duct. The probe insertion depth is adjustable to permit sensor to be located at center, to optimize measurement accuracy. (Refer to PROBE INSERTION GUIDELINE DRAWING and CHART, pages 14 & 15.)

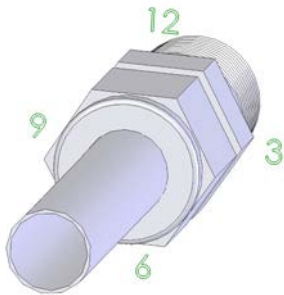

Insert the probe shaft tubing into the compression fitting to the position indicated in the Probe Insertion guidelines.

INSTALLATION INSTRUCTIONS

1. Insert tubing into the tube fitting.
2. Make sure that the tubing is positioned properly per the PROBE INSERTION GUIDELINE DRAWING AND CHART, pages 14 & 15.
3. **Due to the variations of tubing diameters, a common starting point is desirable. Therefore, tighten the nut until the tubing will not turn by hand or move axially in the fitting.**
4. Scribe the nut at the 6 o'clock position.
5. While holding fitting body steady, tighten the nut 1¼ turns to the 9 o'clock position.

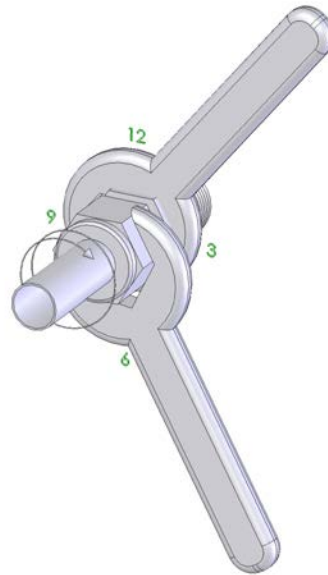

While holding the fitting body steady, tighten the nut one and one-quarter turns to the 9 o'clock position.

CAPTIVE FLOW CONDITIONERS

Can Be Installed in Conjunction with Insertion Style Flow Meters

IMPORTANT The location of the probe must be exactly one pipe ID diameter (i.e., 4" in a 4" pipe; 6" in a 6" pipe, etc.) downstream of the Captive Flow Conditioning assembly. The Captive Flow Conditioners are always designed to be separated by one pipe diameter. See drawing below. The probe location must be one pipe ID diameter downstream of Flow Conditioner, or errors will occur.

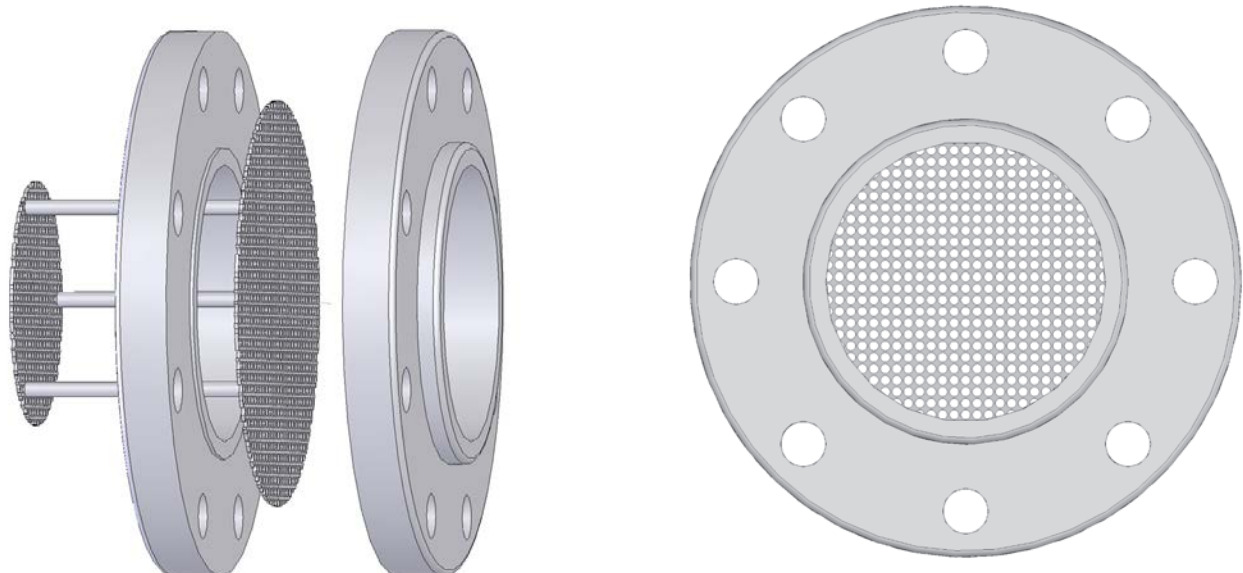

Front View of one of the Conditioning Plates

Note: See table on page 11 (last Column) for Straight Run Requirement

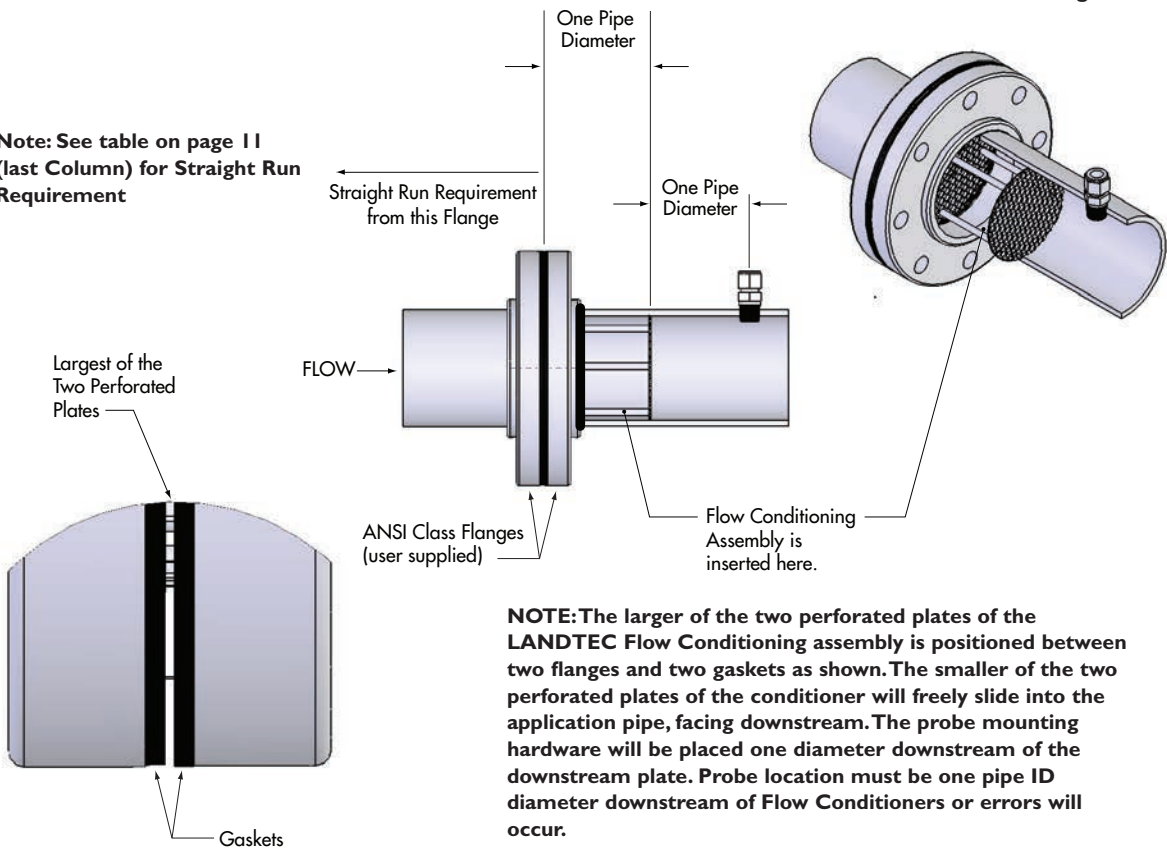

NOTE: The larger of the two perforated plates of the LANDTEC Flow Conditioning assembly is positioned between two flanges and two gaskets as shown. The smaller of the two perforated plates of the conditioner will freely slide into the application pipe, facing downstream. The probe mounting hardware will be placed one diameter downstream of the downstream plate. Probe location must be one pipe ID diameter downstream of Flow Conditioners or errors will occur.

PROBE INSERTION GUIDELINE DRAWING¹

Choose the longest straight-run section of pipe available to allow a uniform, well-developed flow profile. Allow for a **minimum** of 15 pipe diameters of straight run upstream, and 5 diameters downstream, depending on the conditions. See chart on page 11. Note, obstructions such as valves, blowers expanders and PVC and HDPE pipes will require additional straight run (contact factory for assistance). Avoid, if possible, installations immediately downstream of bends, fans, nozzles, heaters and especially valves, or anything else installed in the line that may cause nonuniform flow profiles and swirls. Otherwise signal output errors could result, unless significantly more straight run is provided, or in the absence of sufficient straight run, Flow Conditioners (page 13) are installed (contact LANDTEC for assistance if needed). Refer to page 13 to see the benefits of incorporating Flow Conditioners.

Insertion styles are available through LANDTEC with a standard 1/2" OD probe support assembly; 3/4" is also available. Standard probe lengths are 6", 12", 15", 18", 24", 30", 36" and 48". A common method of mounting the probe assembly through a pipe wall or duct (if ambient air) is with a compression fitting (STCF05). A LANDTEC valve assembly (SVA05) is useful and highly recommended for pressurized applications or

other gases, such as Natural Gas. Flange mounting is optionally available.

LANDTEC insertion style flow meters can be

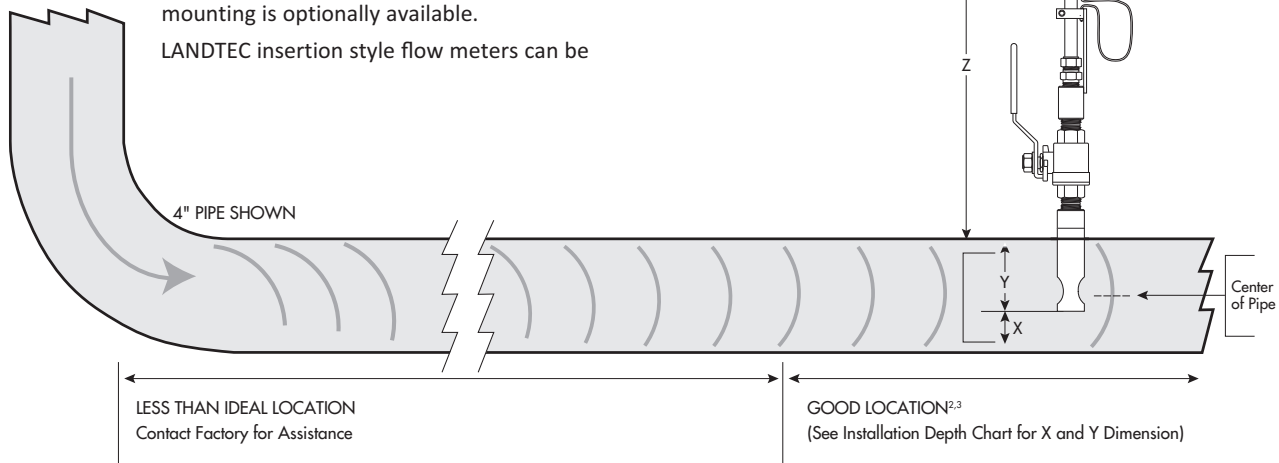

assembled and calibrated for use in virtually any size pipe or duct (as small as 1"). LANDTEC insertion flow meters include a probe assembly that supports the sensing element (a self-heated flow sensor and a temperature/reference sensor); a sensor drive circuit; microprocessor meter board, and transmitter enclosure. The probe assembly must be inserted into the correct position in the process gas flow conduit to allow the gas to flow through the sensor "window" across the sensor element. The "sensing point" or active part of the sensor (0.5" from the end of the probe) should be positioned as per the drawing below and the Installation Depth Chart on page 15.

Installation Depth

The center of the pipe (assuming a well developed turbulent flow profile) is fairly flat, and easy to locate. See "Installation Depth Chart" on next page to determine proper insertion depth.

1. LIA Industrial Meter shown in drawing. Note, probe is not bi-directional.
2. Probe should be inserted per Installation Depth Chart (see following page), so sensors are in the center of the pipe.
3. The portion of the probe that remains outside of the pipe, is simply the factory ordered probe length (i.e. "-15" = 15 inches) minus the "Y" dimension.

INSTALLATION DEPTH CHART
Methods for Probe Insertion to Pipe Center

METHOD 1

Using charts below, select pipe size (column 1), determine X. Insert probe until the end touches the bottom of the pipe (ID), mark probe as it exits top of fitting. Lift probe distance "X" and tighten compression fitting.

METHOD 2

Using charts below¹, select pipe size (column 1), determine Y. Subtract Y from the factory supplied probe length. That difference Z (see drawing on page 14) should be outside of the pipe, and is measured from the bottom of the enclosure of the probe weld to pipe OD.

- 1 For other Pipe Schedules, such as Schedule 10, contact LANDTEC, however the Y dimension will be the same for any Schedule Pipe
- 2 The 1" Pipe Size needs to have the Probe "Bottomed Out" (option "BOT"); the calibration method for the 1½" Pipe is either as shown below, or with option "BOT"

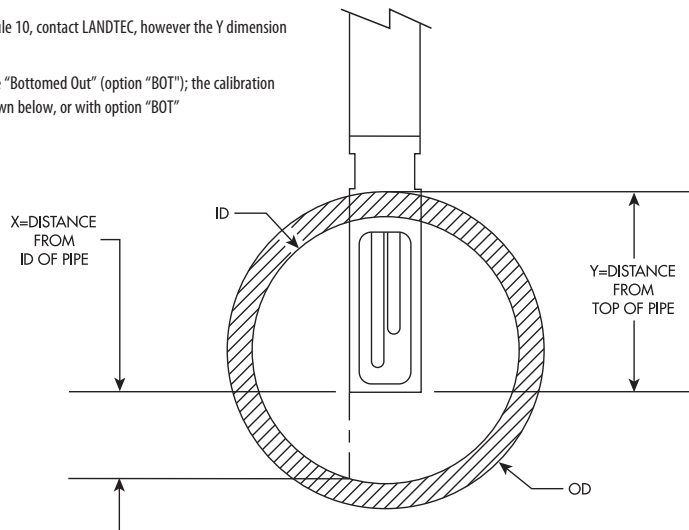

SCHEDULE 40 PIPE ²					
PIPE SIZE	OD	ID	X	Y	PIPE AREA
1"	C O N S U L T F A C T O R Y				
1.5"	1.900	1.610	.20"	1.56"	0.0141
2"	2.375	2.067	.40"	1.82"	0.0233
2.5"	2.875	2.469	.60"	2.07"	0.0332
3"	3.500	3.068	.90"	2.38"	0.0513
4"	4.500	4.026	1.40"	2.86"	0.0884
6"	6.625	6.065	2.40"	3.95"	0.2006
8"	8.625	7.981	3.40"	4.90"	0.3474
10"	10.750	10.020	4.40"	6.00"	0.5476
12"	12.750	11.938	5.50"	7.00"	0.7773
14"	14.000	13.124	6.00"	7.50"	0.9394
16"	16.000	15.000	7.00"	8.60"	1.2272
18"	18.000	16.876	8.00"	9.60"	1.5533
24"	24.000	22.625	10.75"	12.60"	2.7919

SCHEDULE 80 PIPE ²					
PIPE SIZE	OD	ID	X	Y	PIPE AREA
1"	C O N S U L T F A C T O R Y				
1.5"	1.900	1.500	.15"	1.56"	0.0123
2"	2.375	1.939	.35"	1.82"	0.0205
2.5"	2.875	2.323	.55"	2.07"	0.0294
3"	3.500	2.900	.80"	2.38"	0.0459
4"	4.500	3.826	1.30"	2.86"	0.0798
6"	6.625	5.761	2.25"	3.95"	0.1810
8"	8.625	7.625	3.25"	4.90"	0.3171
10"	10.750	9.750	4.25"	6.00"	0.5185
12"	12.750	11.374	5.13"	7.00"	0.7056
14"	14.000	12.500	5.70"	7.50"	0.8522
16"	16.000	14.312	6.60"	8.60"	1.1172
18"	18.000	16.124	7.50"	9.60"	1.4180
24"	24.000	21.562	10.25"	12.60"	2.5357

Large Duct or Stack Applications

CONFIGURATION FOR UTILIZING FOUR (4) LANDTEC INSERTION MASS FLOW METERS FOR LARGE ROUND PIPES OR DUCTS LARGER THAN 36" TO MINIMIZE EFFECTS OF VARYING FLOW PROFILES
(It is recommended that Factory be contacted to assist with applications of this nature)

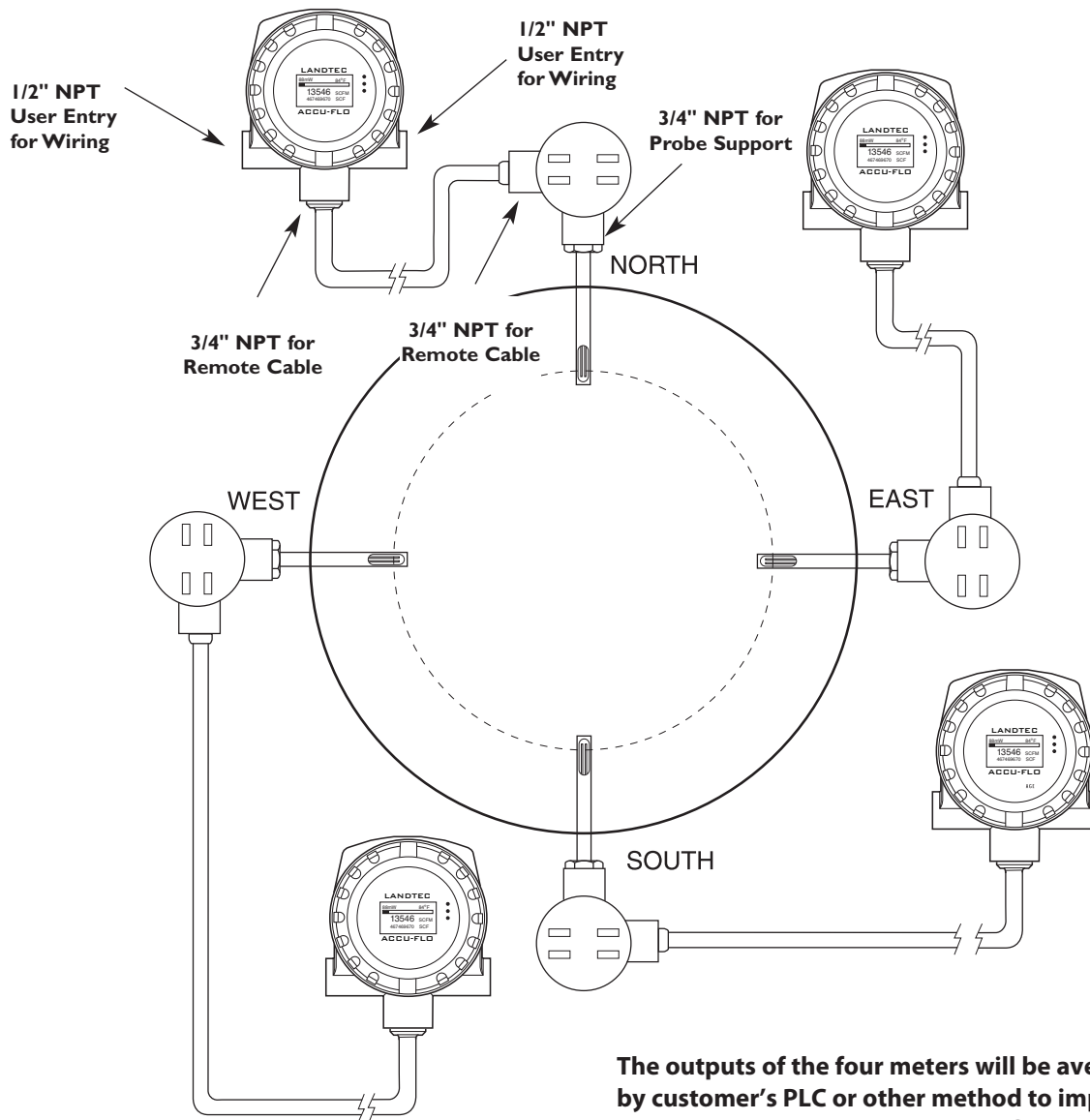

The outputs of the four meters will be averaged by customer's PLC or other method to improve overall accuracy in measuring the flow rate. (For medium sized round pipes [18" to 36"], two meters, on the opposite side of the same diameter, may be sufficient [insert parallel to an upstream 90 degree bend for optimal benefit.]) Note, in this configuration, each sensor needs to be averaged.

In-Line Flow Meter Application

IN-LINE FLOW METERS

In-line mounting styles are available through LANDTEC in sizes from 1/4" pipe through 4" pipe. Threaded male NPT ends are standard up to 2-1/2"; ANSI 150lb flanged ends are recommended for 3" and 4" models. Contact the factory if optional end mounting styles are required. Pipe sizes in excess of 4" require the insertion style mass flow meter.

The in-line style flow meter assembly flow section is typically specified to match the user's flow conduit and is plumbed directly in the flow line by threading, flanging, welding, etc. DO NOT USE REDUCERS.

It includes the sensing element (a self-heated flow sensor and a temperature/reference sensor) mounted directly in the specified flow section for exposure to the process gas; a sensor drive circuit; microprocessor meter board, and transmitter enclosure.

All in-line Flow Meters, 1/2" and up have built-in Flow Conditioners. See Table (page 10) for Upstream Straight run requirements. **Note**, the 1/4" and 3/8" do not have Flow Conditioners and thus require more straight run.

FLOW CONDITIONING SCREENS FOR IN-LINE FLOW BODIES 1/2" AND UP¹

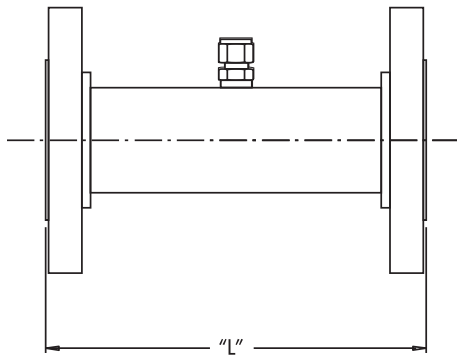

LENGTH "L" SAME AS NON-FLANGED METER
 (See table on page 27. For example, 1"x8" flow body has an 8" length. The length will be the same whether an NPT flow body, or whether flanged. If a flanged flow body, the 8" dimension will be a Face-to-Face dimension.)

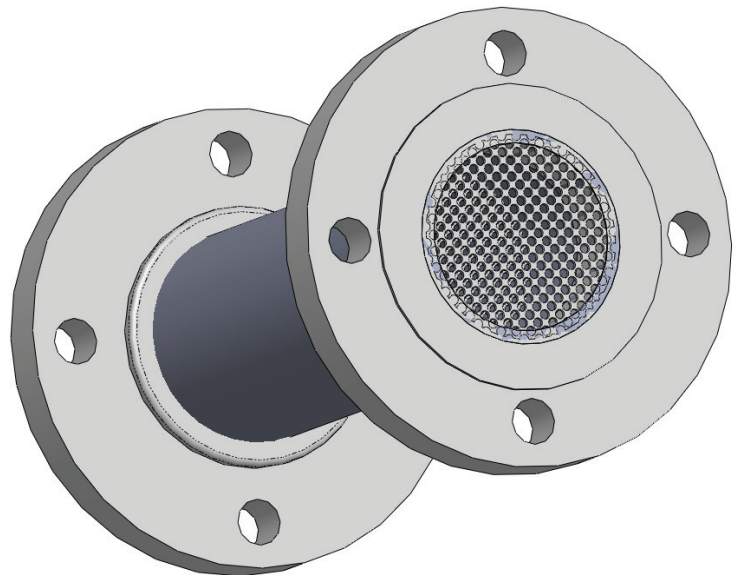

Screens shown with NPT fitting.

¹ Note, Flow conditioning is also available for Insertion Meter applications (see page 13)

ACCU-FLO Integral (Series LIA)

SEE "WIRING" ON PAGE 10 FOR INSTRUCTIONS ON HOW TO REMOVE REAR LID;
SEE FOLLOWING PAGES FOR TERMINAL HOOKUP

INSIDE COVER VIEW

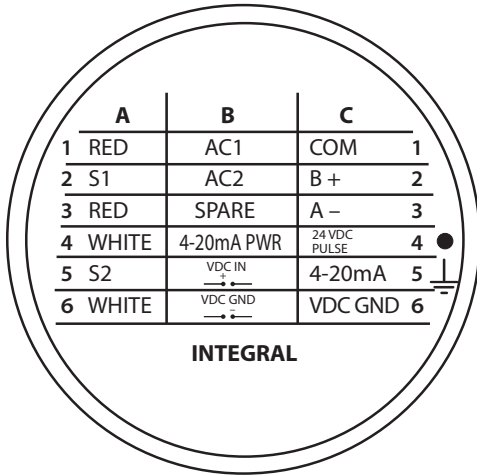

INSIDE BODY VIEW

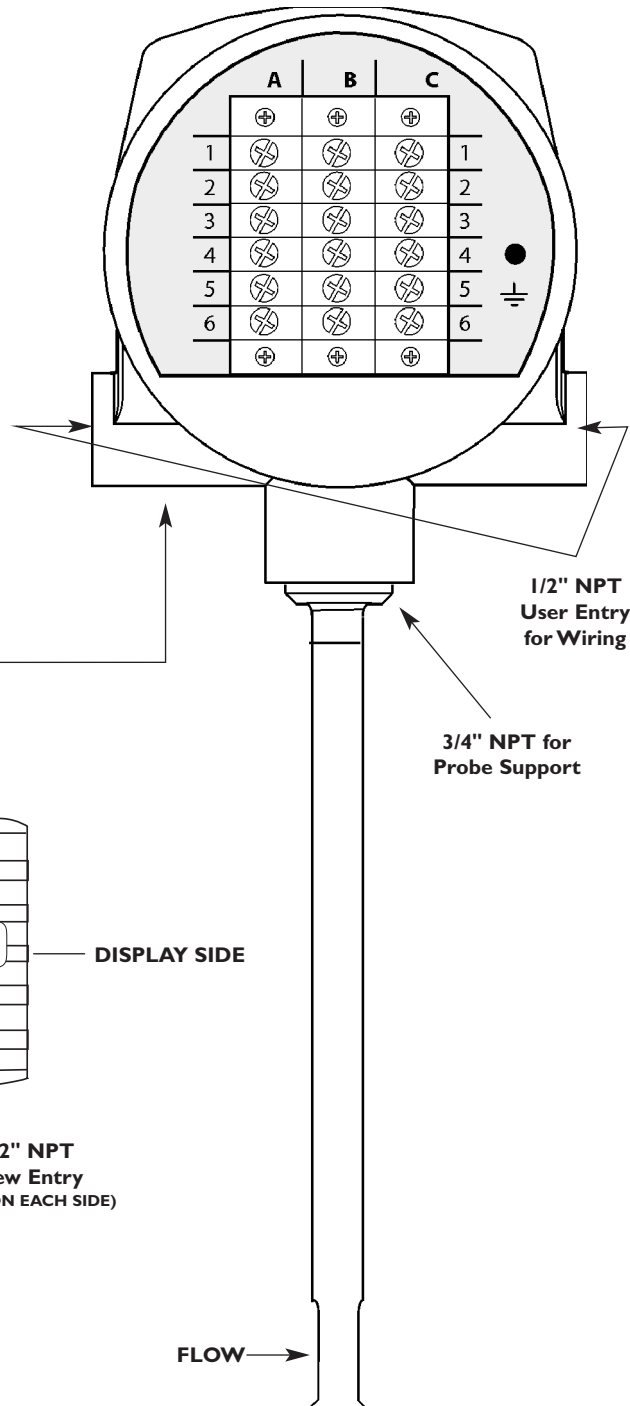

TERMINAL BLOCK SIDE

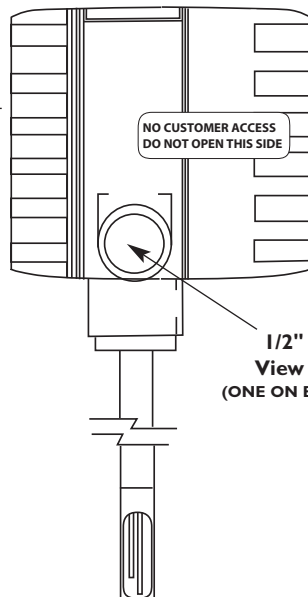

DISPLAY SIDE

24 VDC ACCU-FLO Integral Terminals (Series LIA)

(APPROVED FOR HAZARDOUS SERVICE⁶)

INSIDE COVER VIEW

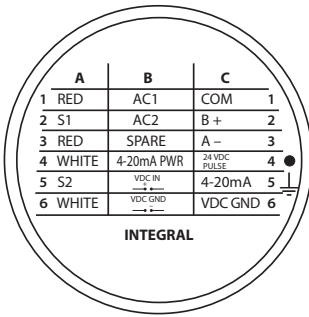

EXTERNALLY POWERED
4-20 mA BY CUSTOMER
CUSTOMER
RETURN

- A1 – RED – VELOCITY SENSOR WIRE (HEATED ELEMENT)
- A2 – NO WIRE
- A3 – RED – VELOCITY SENSOR WIRE (HEATED ELEMENT)
- A4 – WHITE – TEMPERATURE SENSOR WIRE
- A5 – NO WIRE
- A6 – WHITE – TEMPERATURE SENSOR WIRE

INSIDE BODY VIEW

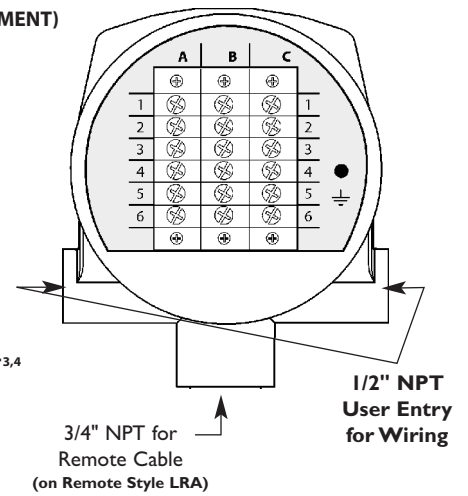

- ** B3 – JUNCTION FOR ISOLATED PULSE
- B4 – 4-20 mA RETURN (-) AND PULSE SOURCE
- B5 – VDC IN – VOLTAGE DC – POSITIVE (+)
- B6 – VDC GND – VOLTAGE DC – GROUND (-)¹

- C1 – COM – RS485 MODBUS GROUND^{1,2}
- C2 – B(+)-RS485_D1
- C3 – A(-)-RS485_D0
- ** C4 – 24 VDC PULSE – 0 TO 24 VDC PULSE OUTPUT^{3,4}
- C5 – 4-20 mA – 4 TO 20 mA SIGNAL DRIVE⁵
- C6 – VDC GND – VOLTAGE DC – GROUND (-)

*B4 and B5 JUMPER
Remove jumper for Externally Sourced 4-20 mA. In this mode, user supplies 9-27 Volts to externally power the 4-20 mA loop, and the 4-20 mA loop becomes optically isolated.

**Note, Flow Meter is supplied with a 10K (1/2 watt) metal film resistor (Resistive Jumper) connected across Terminals C4 and C6. For externally powered operation, in addition to removing B4 & B5 Jumpers, it is necessary to connect C4 Resistive Jumper to Terminal B3 instead of C6. Note, B3 must be connected to the External Sources common in order to enable the optically isolated pulse output. In this mode, Pulse Output is optically isolated. Pulsed Output voltage will depend on customer source voltage. Use LANDTEC Resistive Jumper only!

NOTE: The LANDTEC (ACCU-FLO) draws 2.4 watts maximum (i.e. 100ma @24VDC)

DESCRIPTION	TERMINALS			NOTES
DC Input Power: 24 VDC ^{7,8}	B5	B6		
	+ VDC	- VDC GND		
Internally Powered: 4-20 mA	C5	C6		Do not remove any Jumpers
	4-20 mA SIGNAL DRIVE	Return		
Internally Powered: Pulsed Output	C4	C6		Do not remove any Jumpers
	24 0	GND		
Externally Powered: 4-20 mA	C5	B4		Remove B4 & B5 Jumper
	4-20 mA SIGNAL DRIVE	4-20 mA EXTERNAL SOURCE		
Externally Powered ⁹ : Pulsed Output	C4	B3		Remove B4 & B5 Jumper and Connect C4 Resistive Jumper to B3
	24 0	JUNCTION FOR PULSE RETURN		
MODBUS	C2	C3	C1	Modbus Ground ¹⁰
	RS485(+)	RS485(-)	MODBUS GROUND (REQ'D)	

1 Specify the LANDTEC (ACCU-FLO) PLUS option in order to have the Modbus Ground (Terminal C1, COM) isolated from the 24 VDC LANDTEC Power Supply Ground (Terminal B6). All other features of ACCU-FLO PLUS are identical to the standard LANDTEC ACCU-FLO, except other voltage available. (See footnote 8)

2 It is important to connect the Ground when using Modbus communications, or ground loop problems may develop. Improper wiring can also damage internal circuitry

3 Note, if customer externally powers the 4-20 mA by removing the jumper, the Pulse voltage output is also effected: The voltage output of the Pulse will follow the customer power (i.e. 24 VDC external power will result in a 24 VDC Pulse [maximum of 50 mA]; 12 VDC external power will result in a 12 VDC Pulse)

4 Pulse width 250 msec default (adjustable with Addresser software)

5 Using LANDTEC Addresser, a Low Flow Cutoff (LFC), commonly referred to as Min Cutoff or Zero Cutoff

can be entered into the FLOW MIN Functions. In Versions 1.82 or higher, the Low Flow Cutoff and the 4-20 mA Scaling are independent of each other. For example: A Low Flow Cutoff (LFC) of 10 SCFM on a Meter with a Full Scale of 100 SCFM will report 0 on the Display and 4 mA on the output. The output will remain at 4 mA until the LFC is exceeded: (ie: 25 SCFM=8 mA). Thus the 4 mA will always be zero based

6 Class I, Div 2, Groups B,C,D,T4 and ATEX Ex na IIC T4

7 24 VDC ±10%

8 Other DC voltages (5 VDC, 12 VDC, 48 VDC) available on ACCU-FLO PLUS. Contact LANDTEC

9 Assumes the 4-20 mA is Externally Powered

10 Modbus Ground becomes isolated from the B6 Power Supply Ground only on ACCU-FLO PLUS version (specify "PLUS")

AC Powered (ACCU-FLO) Integral Terminals (Series LIA)⁶

INSIDE COVER VIEW

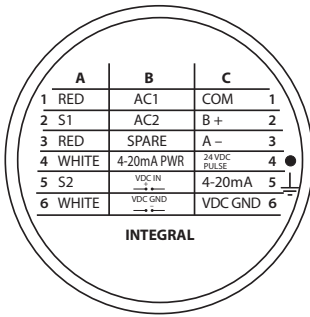

EXTERNALLY POWERED
4-20 mA BY CUSTOMER

CUSTOMER
RETURN

- A1 – RED – VELOCITY SENSOR WIRE (HEATED ELEMENT)
- A2 – NO WIRE
- A3 – RED – VELOCITY SENSOR WIRE (HEATED ELEMENT)
- A4 – WHITE – TEMPERATURE SENSOR WIRE
- A5 – NO WIRE
- A6 – WHITE – TEMPERATURE SENSOR WIRE

- B1 – AC1 – AC VOLTAGE
- B2 – AC2 – AC VOLTAGE
- B3 – JUNCTION FOR ISOLATED PULSE
- B4 – 4-20 mA RETURN (-) AND PULSE SOURCE
- B5 – VDC IN – VOLTAGE DC – POSITIVE (+)
- B6 – VDC GND – VOLTAGE DC – GROUND (-)¹

- C1 – COM – RS485 MODBUS GROUND^{1,2}
- C2 – B(+)-RS485_D1
- C3 – A(-)-RS485_D0
- C4 – 24 VDC PULSE – 0 TO 24 VDC PULSE OUTPUT^{3,4}
- C5 – 4-20 mA – 4 TO 20 mA SIGNAL DRIVE⁵
- C6 – VDC GND – VOLTAGE DC – GROUND (-)

INSIDE BODY VIEW

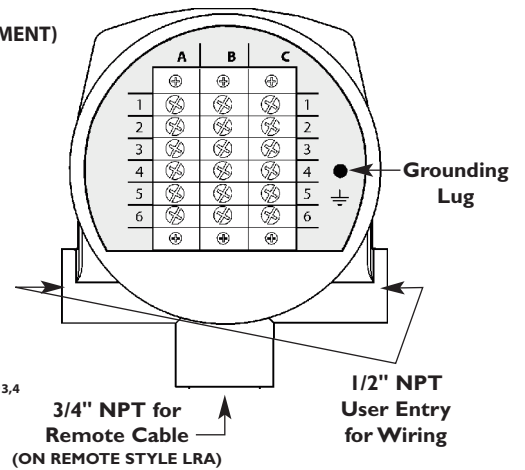

*B4 and B5 JUMPER Remove jumper for Externally Sourced 4-20 mA. In this mode, user supplies 9-27 Volts to externally power the 4-20 mA loop, and the 4-20 mA loop becomes optically isolated.

**Note, Flow Meter is supplied with a 10K (1/2 watt) metal film resistor (Resistive Jumper) connected across Terminals C4 and C6. For externally powered operation, in addition to removing B4 & B5 Jumpers, it is necessary to connect C4 Resistive Jumper to Terminal B3 instead of C6. Note, B3 must be connected to the External Sources common in order to enable the optically isolated pulse output. In this mode, Pulse Output is optically isolated. Pulsed Output voltage will depend on customer source voltage. Use LANDTEC Resistive Jumper only!

NOTE: The LANDTEC (ACCU-FLO) draws 2.4 watts maximum (i.e. 100ma @24VDC)

DESCRIPTION	TERMINALS			NOTES
AC Input Power: 115 VAC/230 VAC	B1	B2		Connect Ground Wire to Grounding Lug
	AC1	AC2		
DC Input Power: 24 VDC ^{7,8}	B5	B6		
	+ VDC	- VDC GND		
Internally Powered: 4-20 mA	C5	C6		Do not remove any Jumpers
	4-20 mA SIGNAL DRIVE	Return		
Internally Powered: Pulsed Output	C4	C6		Do not remove any Jumpers
	24 VDC PULSE WAVEFORM	GND		
Externally Powered: 4-20 mA	C5	B4		Remove B4 & B5 Jumper
	4-20 mA SIGNAL DRIVE	4-20 mA EXTERNAL SOURCE		
Externally Powered⁹: Pulsed Output	C4	B3		Remove B4 & B5 Jumper and Connect C4 Resistive Jumper to B3
	24 VDC PULSE WAVEFORM	JUNCTION FOR PULSE RETURN		
MODBUS	C2	C3	C1	Modbus Ground ¹⁰
	RS485(+)	RS485(-)	MODBUS GROUND (REQ'D)	

- 1 Specify the LANDTEC ACCU-FLO PLUS option in order to have the Modbus Ground (Terminal C1, COM) isolated from the 24 VDC LANDTEC Power Supply Ground (Terminal B6). All other features of ACCU-FLO PLUS are identical to the standard LANDTEC ACCU-FLO, except other voltage available. (See footnote 8)
- 2 It is important to connect the Ground when using Modbus communications, or ground loop problems may develop. Improper wiring can also damage internal circuitry
- 3 Note, if customer externally powers the 4-20 mA by removing the jumper, the Pulse voltage output is also effected: The voltage output of the Pulse will follow the customer power (i.e. 24 VDC external power will result in a 24 VDC Pulse [maximum of 50 mA]; 12 VDC external power will result in a 12 VDC Pulse)
- 4 Pulse width 250 msec default (adjustable with Addresser software)
- 5 Using LANDTEC Addresser, a Low Flow Cutoff (LFC), commonly referred to as Min Cutoff or Zero Cutoff

- 6 can be entered into the FLOW MIN Functions. In Versions 1.82 or higher, the Low Flow Cutoff and the 4-20 mA Scaling are independent of each other. For example: A Low Flow Cutoff (LFC) of 10 SCFM on a Meter with a Full Scale of 100 SCFM will report 0 on the Display and 4 mA on the output. The output will remain at 4 mA until the LFC is exceeded: (ie: 25 SCFM=8 mA). Thus the 4 mA will always be zero based
- 7 This version does not have Hazard Approvals
- 8 24 VDC ±10%
- 9 Other DC voltages (5 VDC, 12 VDC, 48 VDC) available on ACCU-FLO PLUS. Contact LANDTEC
- 10 Assumes the 4-20 mA is Externally Powered
- 11 Modbus Ground becomes isolated from the B6 Power Supply Ground only on ACCU-FLO PLUS version (specify "PLUS")

ACCU-FLO Remote (Series LRA)

SEE "WIRING" ON PAGE 10 FOR INSTRUCTIONS ON HOW TO REMOVE REAR LID;
SEE FOLLOWING PAGES FOR TERMINAL HOOKUP

INSIDE COVER VIEW

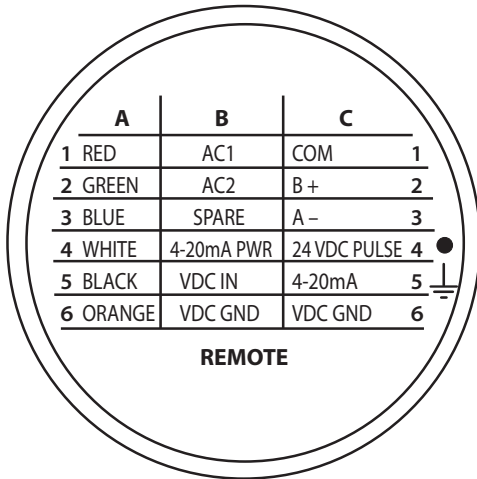

INSIDE BODY VIEW

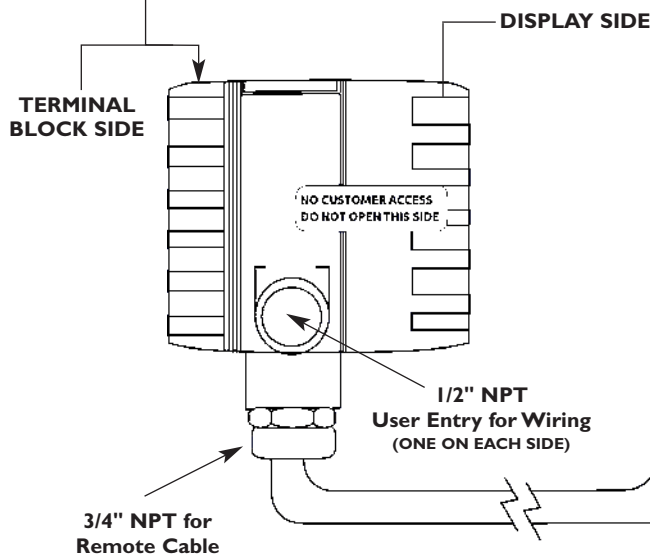
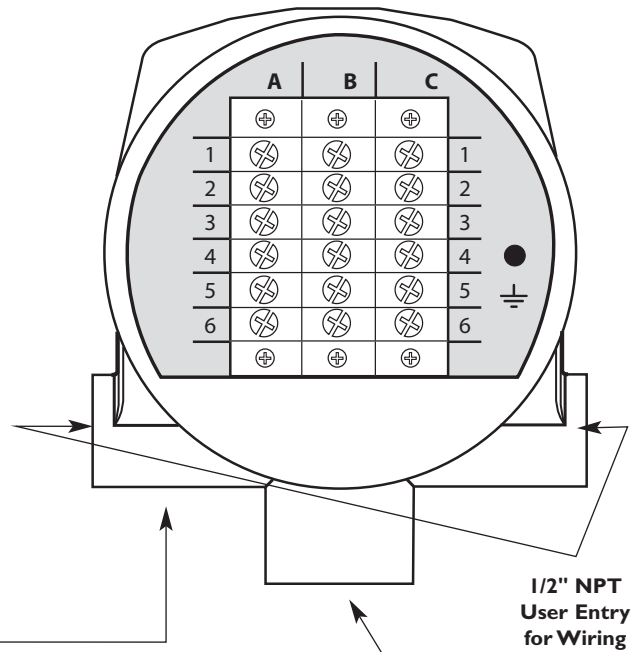

3/4" NPT for
Remote Cable
(ON REMOTE STYLE LRA)

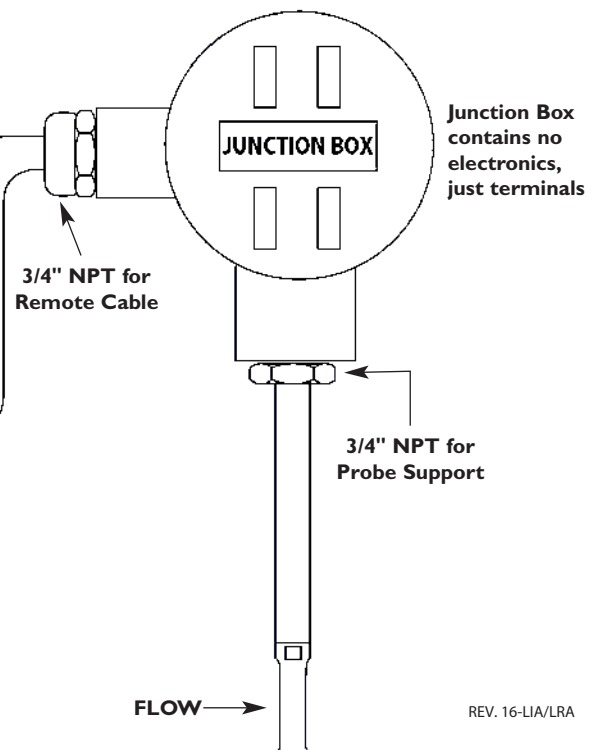

24 VDC ACCU-FLO Remote Terminals (Series LRA)

(APPROVED FOR HAZARDOUS SERVICE⁶)

INSIDE COVER VIEW

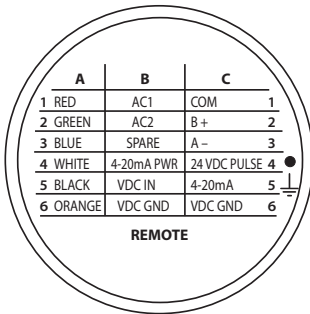

EXTERNALLY POWERED
4-20 mA BY CUSTOMER

CUSTOMER
RETURN

- A1 – RED – VELOCITY SENSOR WIRE (HEATED ELEMENT)
- A2 – GREEN – SENSE WIRE
- A3 – BLUE – VELOCITY SENSOR WIRE (HEATED ELEMENT)
- A4 – WHITE – TEMPERATURE SENSOR WIRE
- A5 – BLACK – SENSE WIRE
- A6 – ORANGE – TEMPERATURE SENSOR WIRE

- ** B3 – JUNCTION FOR ISOLATED PULSE
- B4 – 4-20 mA RETURN (-) AND PULSE SOURCE
- B5 – VDC IN – VOLTAGE DC – POSITIVE (+)
- B6 – VDC GND – VOLTAGE DC – GROUND (-)¹

- C1 – COM – RS485 MODBUS GROUND^{1,2}
- C2 – B(+)-RS485_D1
- C3 – A(-)-RS485_D0
- ** C4 – 24 VDC PULSE – 0 TO 24 VDC PULSE OUTPUT^{3,4}
- C5 – 4-20 mA – 4 TO 20 mA SIGNAL DRIVE⁵
- C6 – VDC GND – VOLTAGE DC – GROUND (-)

INSIDE BODY VIEW

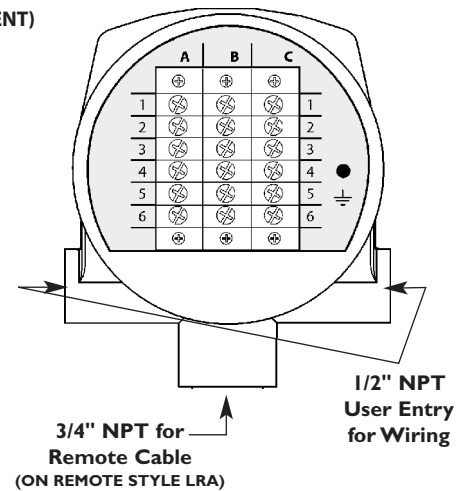

*B4 and B5 JUMPER Remove jumper for Externally Sourced 4-20 mA. In this mode, user supplies 9-27 Volts to externally power the 4-20 mA loop, and the 4-20 mA loop becomes optically isolated.

**Note, Flow Meter is supplied with a 10K (1/2 watt) metal film resistor (Resistive Jumper) connected across Terminals C4 and C6. For externally powered operation, in addition to removing B4 & B5 Jumpers, it is necessary to connect C4 Resistive Jumper to Terminal B3 instead of C6. Note, B3 must be connected to the External Sources common in order to enable the optically isolated pulse output. In this mode, Pulse Output is optically isolated. Pulsed Output voltage will depend on customer source voltage. Use LANDTEC Resistive Jumper only!

NOTE: The LANDTEC ACCU-FLO draws 2.4 watts maximum (i.e. 100ma @24VDC)

DESCRIPTION	TERMINALS		NOTES
DC Input Power: 24 VDC ^{7,8}	B5 + VDC	B6 - VDC GND	
Internally Powered: 4-20 mA	C5 4-20 mA SIGNAL DRIVE	C6 Return	Do not remove any Jumpers
Internally Powered: Pulsed Output	C4 24 0	C6 GND	Do not remove any Jumpers
Externally Powered: 4-20 mA	C5 4-20 mA SIGNAL DRIVE	B4 4-20 mA EXTERNAL SOURCE	Remove B4 & B5 Jumper
Externally Powered?: Pulsed Output	C4 24 0	B3 JUNCTION FOR PULSE RETURN	Remove B4 & B5 Jumpers and Connect C4 Resistive Jumper to B3
MODBUS	C2 RS485(+)	C3 RS485(-)	C1 MODBUS GROUND REQ'D
			Modbus Ground ¹⁰

1 Specify the LANDTEC ACCU-FLO PLUS option in order to have the Modbus Ground (Terminal C1, COM) isolated from the 24 VDC LANDTEC Power Supply Ground (Terminal B6). All other features of ACCU-FLO PLUS are identical to the standard LANDTEC ACCU-FLO, except other voltage available. (See footnote 8)

2 It is important to connect the Ground when using Modbus communications, or ground loop problems may develop. Improper wiring can also damage internal circuitry

3 Note, if customer externally powers the 4-20 mA by removing the jumper, the Pulse voltage output is also effected: The voltage output of the Pulse will follow the customer power (i.e. 24 VDC external power will result in a 24 VDC Pulse [maximum of 50 mA]; 12 VDC external power will result in a 12 VDC Pulse)

4 Pulse width 250 msec default (adjustable with Addresser software)

5 Using LANDTEC Addresser, a Low Flow Cutoff (LFC), commonly referred to as Min Cutoff or Zero Cutoff

can be entered into the FLOW MIN Functions. In Versions 1.82 or higher, the Low Flow Cutoff and the 4-20 mA Scaling are independent of each other. For example: A Low Flow Cutoff (LFC) of 10 SCFM on a Meter with a Full Scale of 100 SCFM will report 0 on the Display and 4 mA on the output. The output will remain at 4 mA until the LFC is exceeded: (ie: 25 SCFM=8 mA). Thus the 4 mA will always be zero based

6 Class I, Div 2, Groups B,C,D,T4 and ATEX Ex na IIC T4

7 24 VDC ±10%

8 Other DC voltages (5 VDC, 12 VDC, 48 VDC) available on ACCU-FLO PLUS. Contact LANDTEC

9 Assumes the 4-20 mA is Externally Powered

10 Modbus Ground becomes isolated from the B6 Power Supply Ground only on ACCU-FLO PLUS version (specify "PLUS")

AC Powered ACCU-FLO Remote Terminals (Series LRA)⁶

INSIDE COVER VIEW

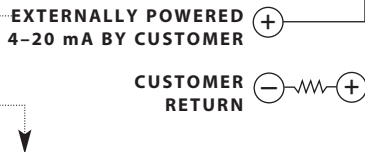
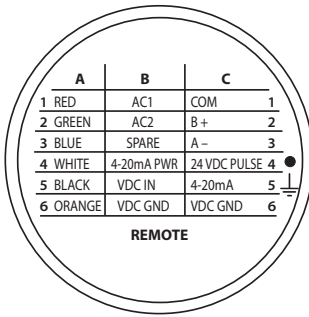

*B4 and B5 JUMPER Remove jumper for Externally Sourced 4-20 mA. In this mode, user supplies 9-27 Volts to externally power the 4-20 mA loop, and the 4-20 mA loop becomes optically isolated.

**Note, Flow Meter is supplied with a 10K (1/2 watt) metal film resistor (Resistive Jumper) connected across Terminals C4 and C6. For externally powered operation, in addition to removing B4 & B5 Jumpers, it is necessary to connect C4 Resistive Jumper to Terminal B3 instead of C6. Note, B3 must be connected to the External Sources common in order to enable the optically isolated pulse output. In this mode, Pulse Output is optically isolated. Pulsed Output voltage will depend on customer source voltage. Use LANDTEC Resistive Jumper only!

NOTE: The LANDTEC ACCU-FLO draws 2.4 watts maximum (i.e. 100ma @24VDC)

- A1 – RED – VELOCITY SENSOR WIRE (HEATED ELEMENT)
- A2 – GREEN – SENSE WIRE
- A3 – BLUE – VELOCITY SENSOR WIRE (HEATED ELEMENT)
- A4 – WHITE – TEMPERATURE SENSOR WIRE
- A5 – BLACK – SENSE WIRE
- A6 – ORANGE – TEMPERATURE SENSOR WIRE

- B1 – AC1 – AC VOLTAGE
- B2 – AC2 – AC VOLTAGE
- ** B3 – JUNCTION FOR ISOLATED PULSE
- * B4 – 4-20 mA RETURN (-) AND PULSE SOURCE
- B5 – VDC IN – VOLTAGE DC – POSITIVE (+)
- B6 – VDC GND – VOLTAGE DC – GROUND (-)¹

- C1 – COM – RS485 MODBUS GROUND^{1,2}
- C2 – B(+)-RS485_D1
- C3 – A(-)-RS485_D0
- * C4 – 24 VDC PULSE – 0 TO 24 VDC PULSE OUTPUT^{3,4}
- C5 – 4-20 mA – 4 TO 20 mA SIGNAL DRIVE⁵
- C6 – VDC GND – VOLTAGE DC – GROUND (-)

INSIDE BODY VIEW

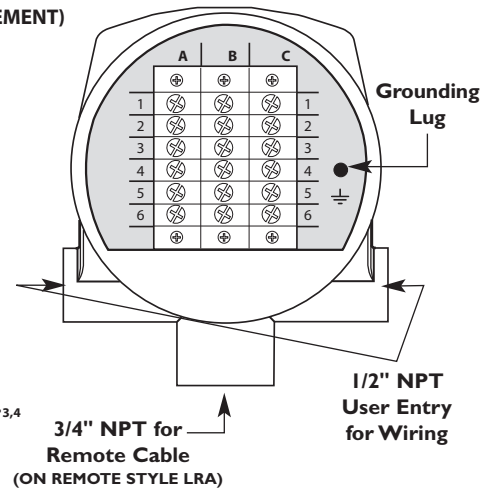

DESCRIPTION	TERMINALS			NOTES
AC Input Power: 115 VAC/230 VAC	B1	B2		Connect Ground Wire to Grounding Lug
	AC1	AC2		
DC Input Power: 24 VDC ^{7,8}	B5	B6		
	+ VDC	- VDC GND		
Internally Powered: 4-20 mA	C5	C6		Do not remove any Jumpers
	4-20 mA SIGNAL DRIVE	Return		
Internally Powered: Pulsed Output	C4	C6		Do not remove any Jumpers
	24 0	GND		
Externally Powered: 4-20 mA	C5	B4		Remove B4 & B5 Jumper
	4-20 mA SIGNAL DRIVE	4-20 mA EXTERNAL SOURCE		
Externally Powered ⁹ : Pulsed Output	C4	B3		Remove B4 & B5 Jumpers and Connect C4 Resistive Jumper to B3
	24 0	JUNCTION FOR PULSE RETURN		
MODBUS	C2	C3	C1	Modbus Ground ¹⁰
	RS485(+)	RS485(-)	MODBUS GROUND (REQ'D)	

1 Specify the LANDTEC ACCU-FLO PLUS option in order to have the Modbus Ground (Terminal C1, COM) isolated from the 24 VDC LANDTEC Power Supply Ground (Terminal B6). All other features of ACCU-FLO PLUS are identical to the standard LANDTEC ACCU-FLO, except other voltage available. (See footnote 8)

2 It is important to connect the Ground when using Modbus communications, or ground loop problems may develop. Improper wiring can also damage internal circuitry

3 Note, if customer externally powers the 4-20 mA by removing the jumper, the Pulse voltage output is also effected: The voltage output of the Pulse will follow the customer power (i.e. 24 VDC external power will result in a 24 VDC Pulse [maximum of 50 mA]; 12 VDC external power will result in a 12 VDC Pulse)

4 Pulse width 250 msec default (adjustable with Addresser software)

5 Using LANDTEC Addresser, a Low Flow Cutoff (LFC), commonly referred to as Min Cutoff or Zero Cutoff

can be entered into the FLOW MIN Functions. In Versions 1.82 or higher, the Low Flow Cutoff and the 4-20 mA Scaling are independent of each other. For example: A Low Flow Cutoff (LFC) of 10 SCFM on a Meter with a Full Scale of 100 SCFM will report 0 on the Display and 4 mA on the output. The output will remain at 4 mA until the LFC is exceeded: (ie: 25 SCFM=8 mA). Thus the 4 mA will always be zero based

6 This version does not have Hazard Approvals

7 24 VDC ±10%

8 Other DC voltages (5 VDC, 12 VDC, 48 VDC) available on ACCU-FLO PLUS. Contact LANDTEC

9 Assumes the 4-20 mA is Externally Powered

10 Modbus Ground becomes isolated from the B6 Power Supply Ground only on ACCU-FLO PLUS version (specify "PLUS")

Junction Box Wiring Terminals for Remote Style Meters (Series LRA) (THERE ARE NO ELECTRONICS INSIDE JUNCTION BOX)

SEE THE PREVIOUS PAGE FOR THE OTHER END OF THE REMOTE WIRING HOOKUP (the electronics side).

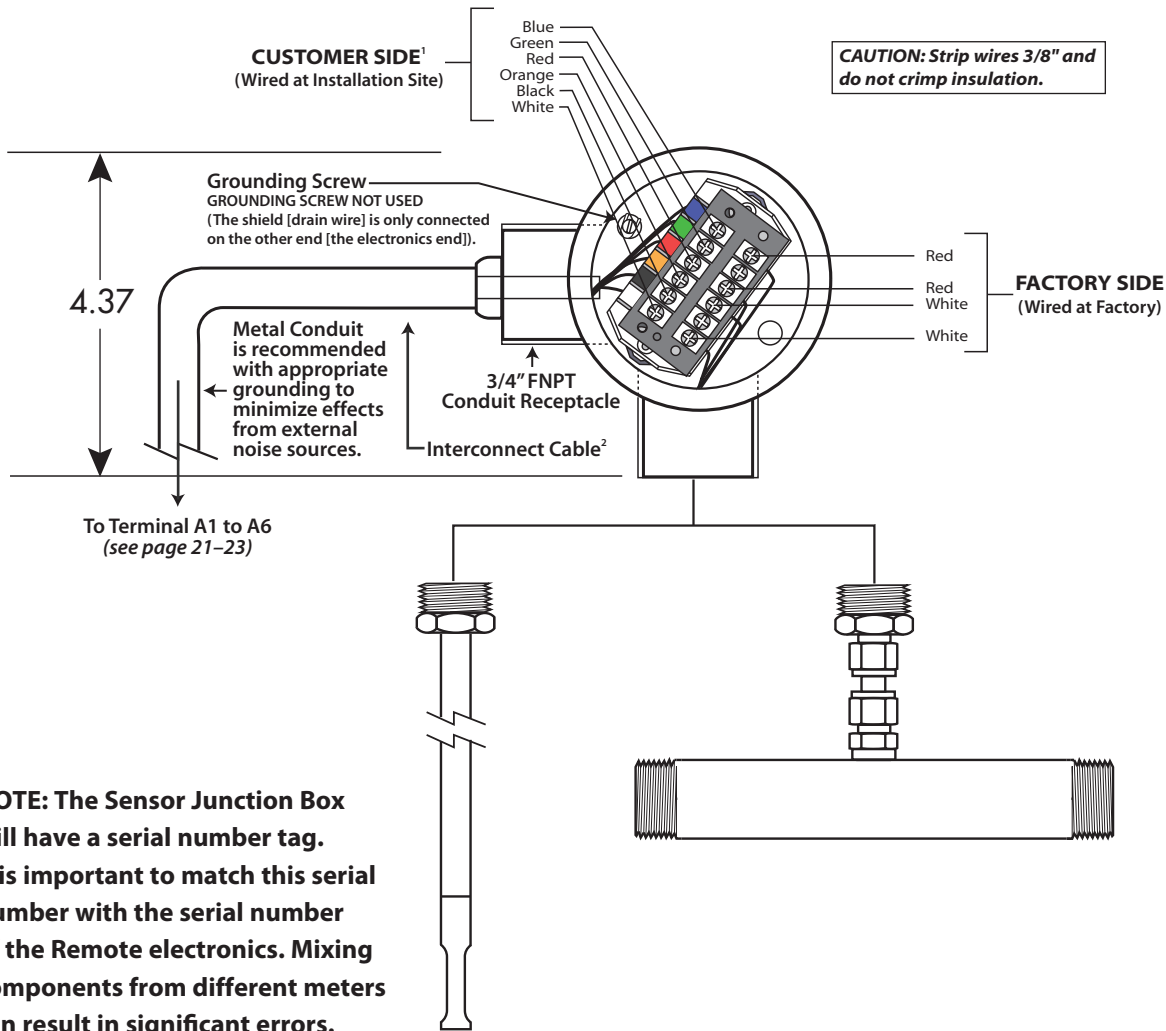

¹ NOTE: There are hidden jumpers (underneath the terminal strip) that short together the Blue and Green wires, and also short together the Black and Orange wires. These extra wires are part of the meter's Lead Length Compensation circuitry, allowing the user to change the length of the interconnect cable (from 0 to 1000 feet) without effecting the accuracy. 25 feet of cable are initially supplied (for cabling longer than 1000 feet, contact LANDTEC).

² LANDTEC supplies 25 feet of cable for the interconnect wires between the Junction Box and the Remote Enclosures: Carroll (manufacturer), Part #C0783, 20 gauge, 6 conductor, foil shielded, grey PVC jacket.

! CAUTION: Cable and cable glands are not for use in hazardous area environments. Power, ground, outputs, shielded cable, seal fittings and conduits are to be supplied by customer.

Section

B

STYLES AND FEATURES

Principle of Operation of the Thermal Mass Flow Meter

LANDTEC Thermal Mass Flow Meters have two sensors constructed of reference grade platinum windings (RTDs). The two RTDs are clad in a protective 316SS sheath and are driven by a proprietary sensor drive circuit. One of the sensors is self-heated (flow sensor), and the other sensor (temperature/reference sensor) measures the gas temperature. The pair is referred to as the sensing element, and is either installed in a probe as an Insertion style, or inserted into a pipe section as an In-Line style flow meter.

As gas flows by the flow sensor, the gas molecules carry heat away from the surface, and the sensor cools down as it loses energy. The sensor drive circuit replenishes the lost energy by heating the flow sensor until it is a constant temperature differential above the reference sensor. The electrical power required to maintain a constant temperature differential is directly proportional to the gas mass flow rate and is linearized to be the output signal of the meter.

It is essential that this constant temperature differential be maintained, even if there are wide fluctuations in gas temperature. It is the function of the LANDTEC hybrid-digital proprietary sensor drive circuit to maintain the differential, whether or not the gas temperature changes, or however quickly molecules cool off the flow sensor. It is also necessary to properly calibrate the device with the actual gas (or close equivalent with certain gases), in the LANDTEC National Institute of Standards certified (NIST) calibration facility. By accomplishing these two critical objectives, the LANDTEC meters provide an extremely repeatable (0.2% of Full Scale) and accurate output directly proportional to the mass flow rate of the gas being measured.

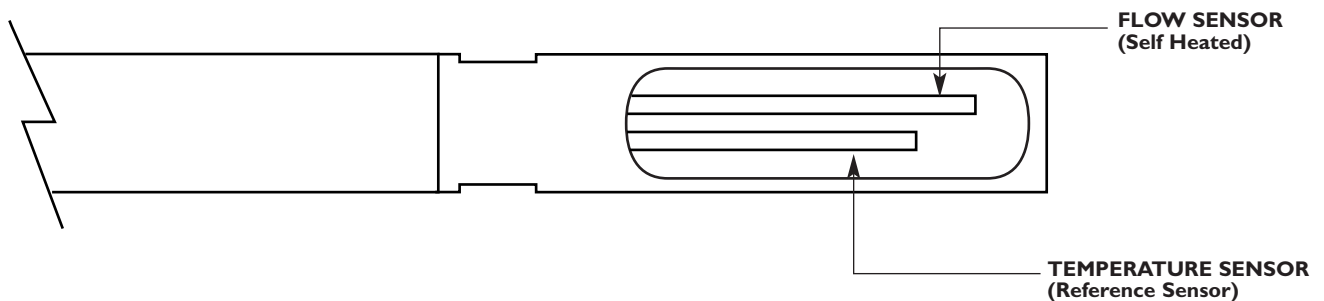

Features and Benefits

LANDTEC ACCU-FLO THERMAL MASS FLOW METER FOR GASES

LANDTEC ACCU-FLO is the top selling meter in our Product Line. The LANDTEC ACCU-FLO Thermal Mass Flow Meter features a bright, high contrast, photo-emissive OLED display of Flow Rate, Total and Temperature in a robust, yet lightweight, dual-compartment industrial enclosure. The flow rate is also displayed graphically in a horizontal bar graph format. The rear compartment is completely separated from the electronics, and has large, easy-to-access, well marked terminals, for ease of customer wiring (see photo below). It is powered by 24 VDC (12 VDC optional, or 115/230 VAC). The power dissipation is under 2.5 watts (e.g. under 100 mA at 24 VDC).

The LANDTEC ACCU-FLO Flow Meter is offered in Integral or Remote Style (which has lead-length compensation up to 1000 feet as well as an Explosion Proof Junction Box). Specify any standard probe length or flow body size. It has a 4-20 mA output as well as a Pulsed Output of Totalized Flow (solid state transistor drive). In addition, LANDTEC ACCU-FLO supports full Modbus® compliant RS485 RTU communications (IEEE 32 Bit Floating Point).

LANDTEC ACCU-FLO is CE approved, CSA and UL approved for Hazardous Service² (see Approvals tab on the website).

CONTINUOUS DIAGNOSTICS & FIELD CONFIGURABILITY

LANDTEC ACCU-FLO has continuous diagnostics. The raw calibration milliwatts (mw) is always displayed in the upper left hand corner of the meter's display. At any time, you can check this reading at a "no flow" condition, and compare the reading to the original reported "zero flow" value noted on the last few lines of your meter's Certificate of Conformance or the flow meter's data tag. This in-situ diagnostic procedure not only checks the sensor performance and the "live zero" calibration point, but it also verifies that the sensor is clean. It essentially provides a means to validate that the meter is operating properly, verifies that there is no shift or drift, and eliminates the need for annual factory calibrations. This simple field diagnostic procedure, in addition, verifies that the sensor is free from contamination, even without inspection.

Although LANDTEC ACCU-FLO is fully configured upon shipment, for the pipe and process conditions requested, if changes are needed, Addresser software is optionally available for field reconfigurability.



REV. 16-LIA/LRA

MAJOR BENEFITS OF THERMAL MASS FLOW METERS

- Direct Mass Flow – No need for separate temperature or pressure transmitters
- High Accuracy and Repeatability – Precision measurement and extraordinary repeatability
- Turndown of 100 to 1 and resolution as much as 1000 to 1
- Low-End Sensitivity – Measures as low as 5 SFPM (e.g., 1 SCFM in a 6" pipe)
- Negligible Pressure Drop – Will not impede the flow or waste energy
- No Moving Parts – Eliminates costly bearing replacements, and prevents undetected accuracy shifts
- Dirt Insensitive – Provides sustained performance
- Low cost-of-ownership
- Ease of installation and convenient mounting hardware

SPECIFIC BENEFITS OF THE LANDTEC ACCU-FLO

- Features In-Situ "Field Zero Calibration Check" of sensor's performance – verifies that the sensor is clean, and assures that there is no drift, or shift in the flow meter
- Compact design of enclosure is only 4 1/8" dia. by 4 1/4" deep (DC Models)
- High contrast photo-emissive OLED display with numerical Flow Rate, Total and Temperature, as well as Graphical Flow Indicator
- Calibration milliwatts (mW) is continuously displayed, providing for ongoing diagnostics
- Photocell activated Screen Saver to extend display life²
- Proprietary digital sensor drive circuit provides enhanced signal stability and unaffected by process temperature & pressure changes
- Modbus compliant RS485 RTU communications
- HART™ communications (optional)
- Isolated 4-20 mA output and pulsed output of Totalized Flow
- Rugged, user-friendly packaging with easy terminal access
- Option for Solar Energy use (12VDC models)
- Remote Style has Lead-Length Compensation. Allows remote electronics up to 1000 feet from probe; Explosion Proof Junction Box has no circuitry, just terminals (suitable for harsh environments)
- Low power dissipation, under 2.5 Watts (e.g. under 100 ma at 24 VDC)
- Field reconfigurability via HART or optional Addresser software
- Flow conditioning built into In-Line flow meters (1/2" and up)
- Captive Flow Conditioners for Insertion meter applications, if required

¹ Only available with 24VDC powered meters

² Note, a built-in photocell continuously monitors the ambient light, and adjusts the display brightness for optimum long-term life, and also senses motion which automatically switches display from Screen Saver mode to Normal mode

LANDTEC ACCU-FLO Styles and Specifications

LANDTEC is your source for monitoring, measuring and controlling the gas mass flow in your industrial process, building management system or environmental application. Our high performance, NIST Traceable, Thermal Mass Flow Meters will help increase productivity, reduce energy costs, maximize product yields, and/or help reduce environmental insult. LANDTEC provides high quality In-Line and Insertion Thermal Mass Flow Meters for a wide variety of industrial, commercial, and environmental monitoring needs, including carbon credit verification for

Greenhouse Gas reduction.

Our experienced application engineers, many of whom have worked in the Thermal Mass Flow marketplace since its inception, will assist you in choosing the proper gas Flow Meter for your application – and they will be pleased to offer installation guidance to assure that the meter(s) selected will perform as accurately as possible. Additionally, our Service Staff stand ready to support you with any after-sale assistance that you may require.

LIA SERIES – INTEGRAL

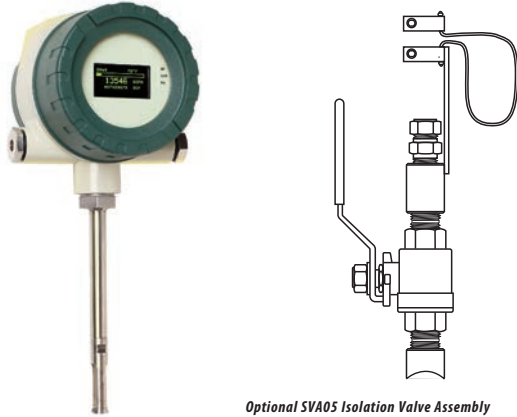

Optional SVA05 Isolation Valve Assembly

LRA SERIES – REMOTE

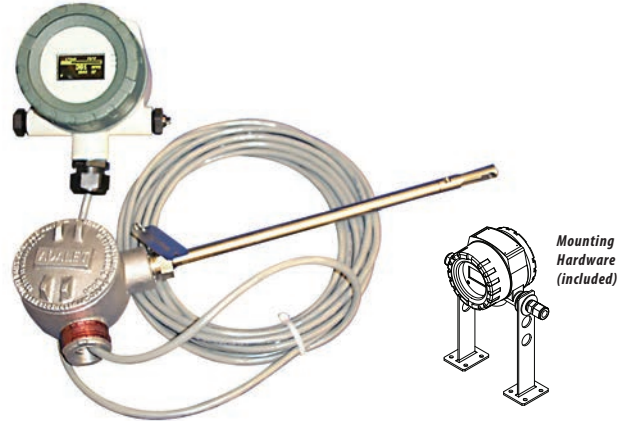

Mounting Hardware (included)

ACCU-FLO LIA/LRA

Standard accuracy is +/- 0.5% of Full Scale +/- 1% of reading with a turn-down of 100 to 1 and resolution as much as 1000 to 1. Repeatability is 0.2%.

NOTE: Enhanced accuracy optionally available with limited turn-down⁴.

The electronics has an isolated 4 to 20 mA output proportional to Mass Flow Rate as well as pulsed outputs of Totalized Flow (24 VDC solid state transistor drive). In addition, Modbus RS485 RTU communications is standard (IEEE 32 Bit Floating Pt).

INTEGRAL STYLE ELECTRONICS

Electronics is Integral Style, with rugged windowed dual compartment NEMA 4 enclosure with local display. The display is a high contrast photo-emissive OLED display with Screen Saver, and it displays Mass Flow Rate, Totalized Flow and Temperature as well as a graphical representation of Flow Rate in a horizontal bar graph format. In addition, the calibration milliwatts (mw) is continuously displayed, providing ongoing diagnostics.

REMOTE STYLE ELECTRONICS

Electronics is Remote Style, with rugged windowed dual compartment NEMA 4 enclosure with display. The display is a high contrast photo-emissive OLED display with Screen Saver, and it displays Mass Flow Rate, Totalized Flow and Temperature as well as a graphical representation of Flow Rate in a horizontal bar graph format. In addition, the calibration milliwatts (mw) is continuously displayed, providing ongoing diagnostics. Includes Remote Mounting Hardware.

The Flow Element's Junction Box is Explosion Proof (Class 1, Div 1, Groups B, C, D), and does not have any electronics – only a wiring terminal block. The Junction Box is connected to the Remote Electronics by 25 feet of lead-length compensated cable. The cable (6-conductor) can be lengthened or shortened without affecting accuracy (max loop resistance 10 ohms, over 1000 feet), if grounded properly.

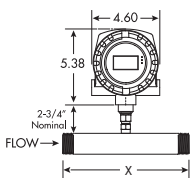

LIA In-Line^{1,3,5}

Flow Element is In-Line Style consisting of a choice of 316 Stainless Steel Schedule 40 Flow Bodies sized from 1/4" x 6" long to 4" x 12" long

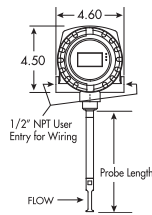

LIA Insertion²

Flow Element is Insertion Style, consisting of a 1/2" OD probe (3/4" optional) with lengths up to 36" long (typically 15" long) suitable for insertion into the center of a process pipe

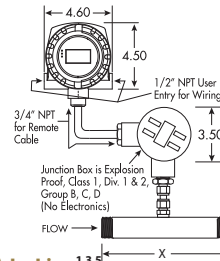

LRA In-Line^{1,3,5}

Flow Element is In-Line Style consisting of a choice of 316 Stainless Steel Schedule 40 Flow Bodies sized from 1/4" x 6" long to 4" x 12" long

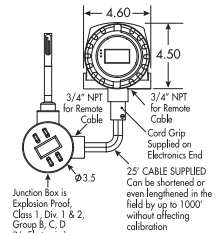

LRA Insertion²

Flow Element is Insertion Style, consisting of a 1/2" OD probe (3/4" optional) with lengths up to 36" long (typically 15" long) suitable for insertion into the center of a process pipe

ENGINEERING SPECIFICATIONS OF OPTIONAL LANDTEC ACCU-FLO PLUS

This is an optional version of LANDTEC ACCU-FLO offering a separate ground for the 24VDC Power Supply (optional 5 VDC or 12 VDC Power Supplies) which isolates the Modbus ground from the power supply ground. All other features of ACCU-FLO PLUS

are identical to the standard LANDTEC ACCU-FLO, except Approvals do not apply at this time.

- 1 Male NPT ends are standard, with flanged ends, tube, or butt weld optionally available
- 2 Mounting hardware such as Isolation Valve Assemblies, Compression Fittings, and Flanges, are optional
- 3 Chart of Flow Body length "X" is on Application Data Sheet on website as well as in the ACCU-FLO O&M
- 4 Enhanced accuracy available upon request, especially if turndown limited. Contact LANDTEC
- 5 Flow Conditioners are built into In-Line Style Flow Bodies from 1/2" to 4"



LANDTEC ACCU-FLO Organic (OLED) Display^{1,2,3}

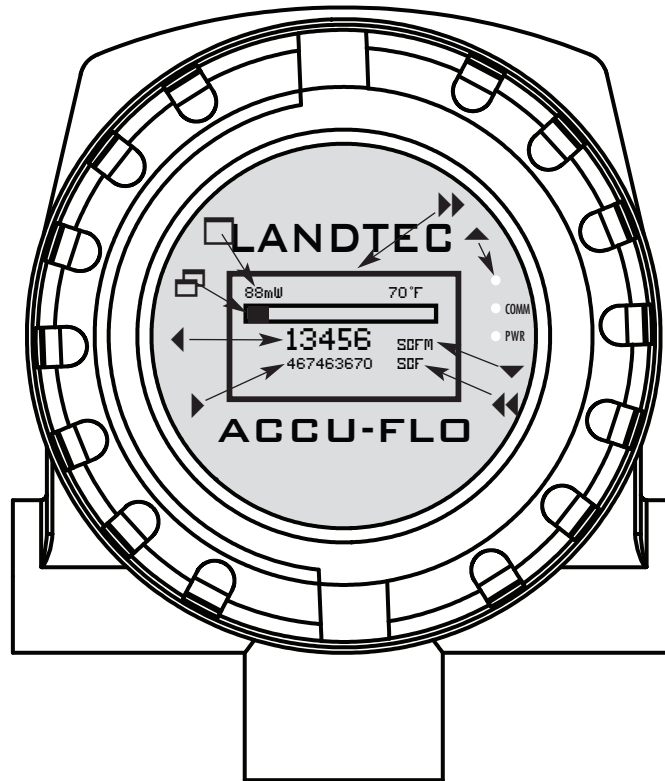

- 1 Raw Calibration milliwatts (mw) for Diagnostics and Periodic "Zero Flow" Calibration Check
- 2 Graphical Indication of Percentage of Full Scale Flow Rate
- 3 Flow Rate
- 4 Totalized Flow (Consumption)
(Value is Retained during Power Outage or Power Cycling)
- 5 Flashes with each pulsed output of consumption
- 6 Engineering Units of Flow Rate (the last digit can be S(seconds), M(minute), H(hour), D(day))
- 7 Engineering Units of Consumption
- 8 Photocell activated Screen Saver extends display life

- 1 Upon start-up, the Revision No., Serial No., and Modbus ID will display for a few seconds. Also the output configurations symbol is momentarily displayed
- 2 Note, a built-in photocell continuously monitors the ambient light, and adjusts the display brightness for optimum long-term life, and also senses motion which automatically switches display from Screen Saver mode to Normal mode
- 3 To view display, wave hand over display or use a flashlight. The Flow Meter displays for one minute, then the Screen Saver resumes

Approvals

HAZARDOUS LOCATION APPROVALS

All 24 VDC Powered LANDTEC ACCU-FLO Meters (LIA Integral Insertion, LIA In-Line, LRA Remote Insertion, LRA Remote In-Line) are approved for Class 1, Div 2, Groups B, C, D, T4 and ATEX: Ex nA IIC T4. AC Powered Meters are not approved.

Testing is in accordance with the following Safety Standards:

- UL1604, Third Edition, Electrical Equipment for Use in Class I and II, Division 2, and Class III Hazardous (Classified) Locations
- CSA C22.2 No. 213-M1987 (R1999), First Edition, Non-incendive Electrical Equipment for Use in Class I, Division 2 Hazardous Locations
- UL/CSA 61010-1, Second Edition, Safety Requirements for Electrical Equipment for Measurement, Control, and Laboratory Use – Part 1: General Requirements

The following is required to comply with the above mentioned Approvals

- 1) Repair of the product (or replacement of components) is not possible by the user
- 2) As noted on the following label (see below) it will contain the following markings: Ex symbol, nA symbol IIC, temperature class
- 3) All ACCU-FLO DC meters will be marked with “X” which means that these Special Conditions of Use will apply:
 - a) The completed meter must be installed with a rigid or flexible metal conduit in order to satisfy approval conditions.
 - b) The meter has been approved for use with the electronics enclosure in an ambient temperature from $-40^{\circ}\text{C} < T_a < 65^{\circ}\text{C}$.
- 4) LANDTEC considers a linear correction suitable for temperatures exceeding the temp code rating of 40°C (104°F) thus no customer correction is needed.

LANDTEC, INC.- ACCU-FLO THERMAL MFM	
Class I, Div 2, Groups B,C,D T4	ATEX: Ex nA IIC T4 X
MODEL #	<input type="text"/>
SERIAL #	<input type="text"/> mW0 = <input type="text"/>
<p>FOR USE IN HAZARDOUS LOCATIONS—CAUTION—DISCONNECT FROM POWER SUPPLY BEFORE OPERATING. KEEP COVER TIGHT WHILE CIRCUITS ARE ALIVE. CONDUIT SEALS MUST BE INSTALLED WITHIN 18" OF THE ENCLOSURE.</p> <p>ATTENTION—OUVRIR LE CIRCUIT AVANT D'ENLEVER LE COUVERCLE GARDER LE COUVERCLE BIEN FERME TANT QUE LES CIRCUITS SONT SOUS TENSION. UN SCHEMEMENT DOIT ETR INSTALLE A MOINS DE 45CM DU BOITER.</p>	

CE CONFORMANCE

All AC & DC Powered LANDTEC Series

LIA (LANDTEC ACCU-FLO-Integral) and Series LRA (LANDTEC ACCU-FLO-Remote) are CE Compliant for the following CE directives:

- EN61000-6-4 for Electromagnetic compatibility;
- EN61000-3-2 for Harmonics;
- EN61000-3-3 for Flicker;
- EN61000-6-2 for Electromagnetic Compatibility (Immunity for Industrial Environments), which includes EN61000-4-2 for ESD;
- EN61000-4-3 for Radiated Immunity;
- EN61000-4-4 for EFT/B; EN61000-4-5 for Surge;
- EN61000 for Conducted Immunity;
- EN61000-4-8 for Magnetic Immunity;
- EN61000-4-11 for Voltage Interruptions

CE MEDICAL CONFORMANCE

Contact LANDTECn if Medical CE Conformance

is required. (AC Powered LANDTEC ACCU-FLO Meters only.)

The Standard is to IEC 60601-1-2:2007 Edition 3

Section

C

DRAWINGS

LIA Series Integral Style Mass Flow Meters

IN-LINE STYLE^{1,3}

150#, 300#, or 600# flanged ends are optionally available. (150# flanges recommended on 3" and 4" Flow Bodies)

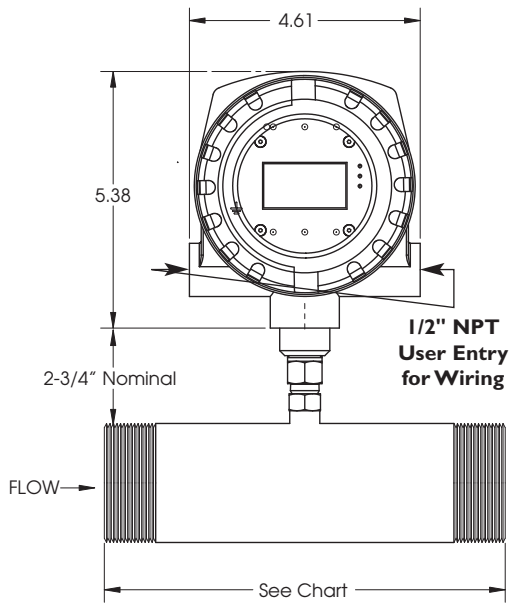

CAUTION:
Do not rotate the Enclosure of In-Line Style Meters relative to the Flow Tube, or the calibration may be effected since the sensors may become misaligned.

IN-LINE METER DIMENSIONS

Pipe Size x Flow Body Length (B) ³
1/4" x 6"
3/8" x 6"
1/2" x 7"
3/4" x 7"
1" x 8"
1-1/4" x 10"
1-1/2" x 12"
2" x 12"
2-1/2" x 12"
3" x 12"
4" x 12"

Depth: DC Enclosure depth is 4.35"
AC Enclosure depth is 5.35"

INSERTION STYLE²

150#, 300#, or 600# flanged mounting is optionally available. Available probe lengths are 6", 12", 15", 18", 24", 30", 36" or 48". Standard probe is 1/2" diameter (3/4" optional – recommended for 36" or 48")

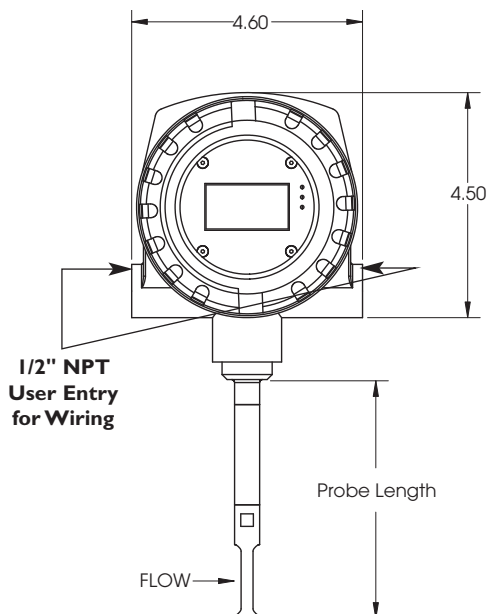

- 1 NPT Fittings standard
- 2 Flanged Mounting available for high pressure operation
- 3 Flow Conditioning built in to Flow Meter Pipe Sizes 1/2" and up. Contact LANDTEC for optional 1/4" tube flow body.

LRA Series Remote Style Mass Flow Meters

IN-LINE STYLE^{1,3,4}

150#, 300#, or 600# flanged ends are optionally available. (150# flange recommended on 3" and 4" Flow Bodies)

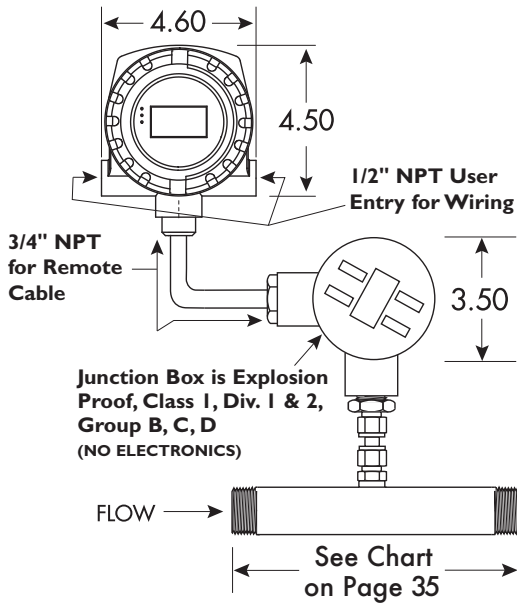

CAUTION: Do not rotate the Junction Box of In-Line Style Meters relative to the Flow Tube, or the calibration may be effected since the sensors may become misaligned.

INSERTION STYLE²

150#, 300#, or 600# flanged mounting is optionally available. Available probe lengths (C) are 6", 12", 15", 18", 24", 30", 36" or 48".

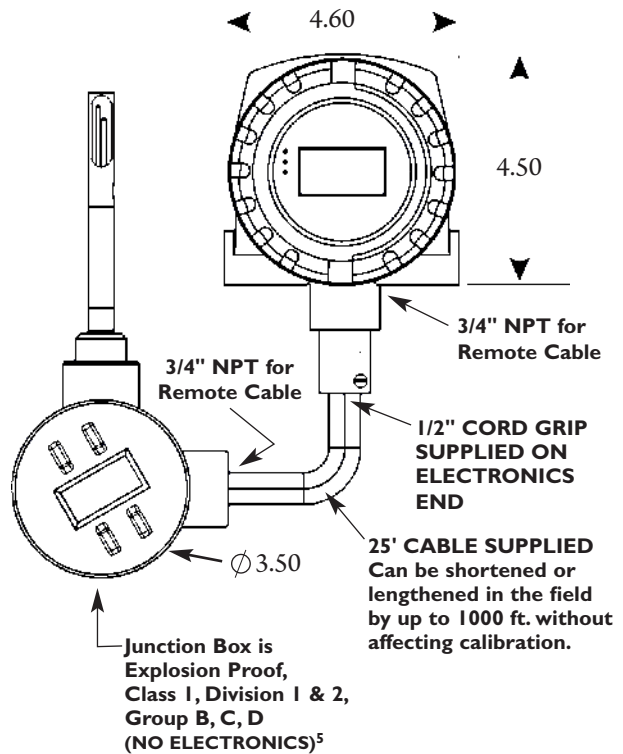

1 NPT Fittings standard
 2 Flanged Mounting available for high pressure operation
 3 Flow Conditioning built in to Flow Meter Pipe Sizes 1/2" and up. Contact LANDTEC for optional 1/4" tube flow body.
 4 See Chart on page 35.
 5 Junction Box has the following certifications: Class I, Groups B,C,D; Class II, Groups E,F,G; Class III; 4X, 7BCD, 9EFG; FM Standard 3615; UL Standard 1203; CSA Standard C22.2 No. 30; and NEMA Compliance

LANDTEC ACCU-FLO Remote Bracket Layout

MOUNTING OPTIONS

1. Overhead with U-bolts (customer supplied) across pipe on each leg
2. Vertically, as shown
3. Horizontally

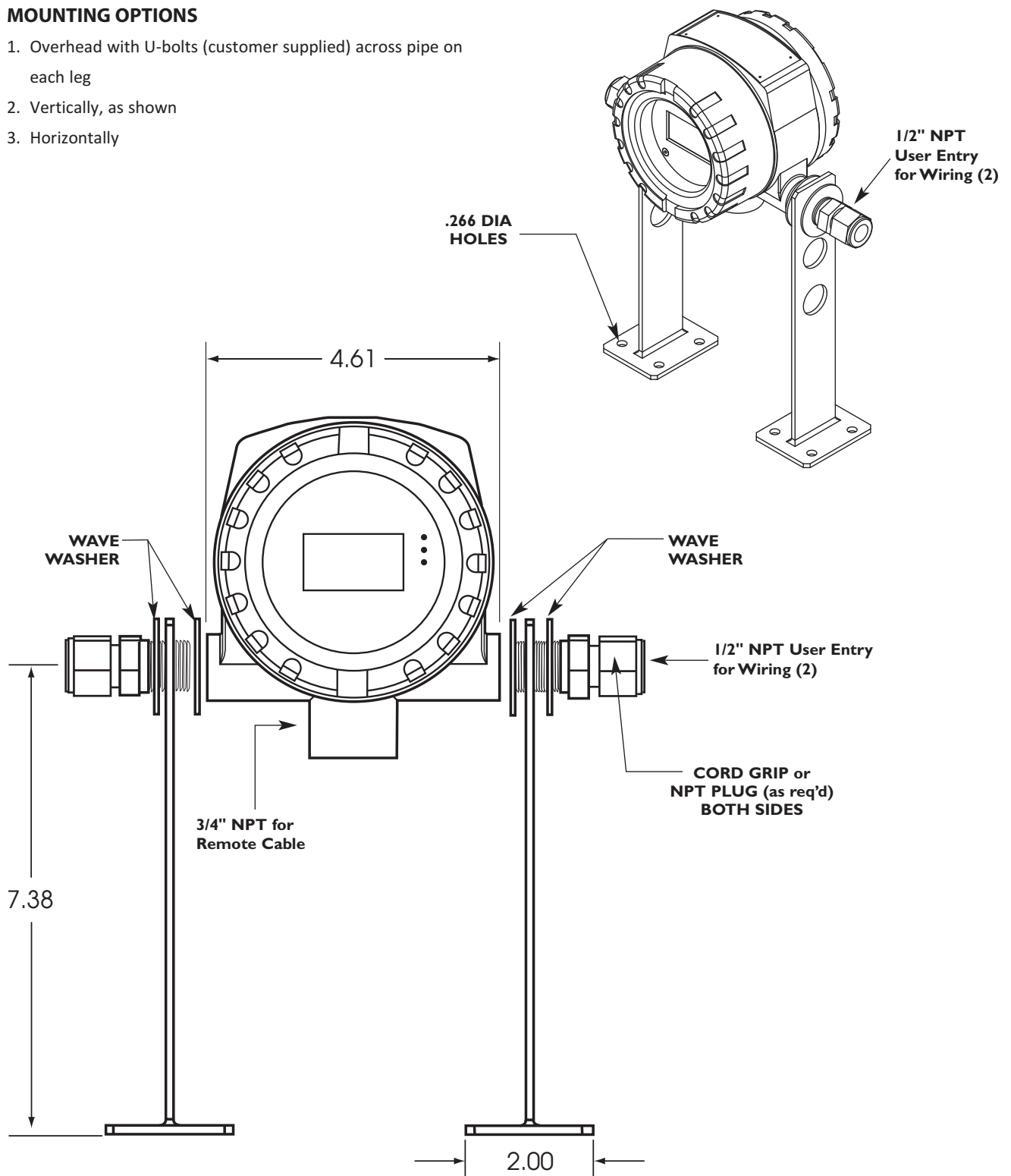

Mounting Hardware³

SVA05 SERIES ISOLATION VALVE ASSEMBLY FOR INSERTION METERS⁴

(for Low Pressure SVA05 see page 39)

Used for pressures to 250 psig¹ (shown for use with 1/2" diameter insertion meters). 150# or 300# flanged mounting is optionally available. Available sizes are 1/2" x 3/4" NPT (SVA05 shown), and 3/4" x 1" NPT for use with 3/4" diameter insertion meters (SVA07).

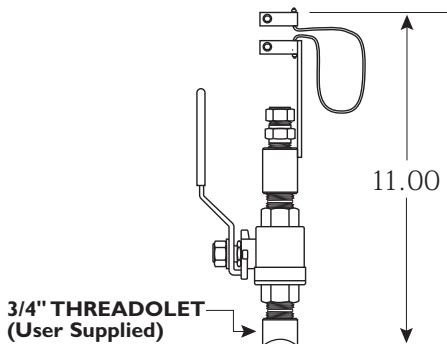

NOTE: User needs to weld a 3/4" female threadolet (of appropriate radius) to mate with existing pipe after a 3/4" hole has been drilled in pipe. The 3/4" Male Coupling of the LANDTEC Isolation Valve Assembly will thread into the user's 3/4" threadolet.

PROBE LENGTH (with sensor)	SAFETY CHAIN LENGTH ²
12"	8.25"
15"	11.25"
18"	14.25"
24"	20.25"

SVA05 SERIES ISOLATION VALVE ASSEMBLY DETAIL^{5,6}

Cut away view of probe inserted through isolation ball valve assembly.

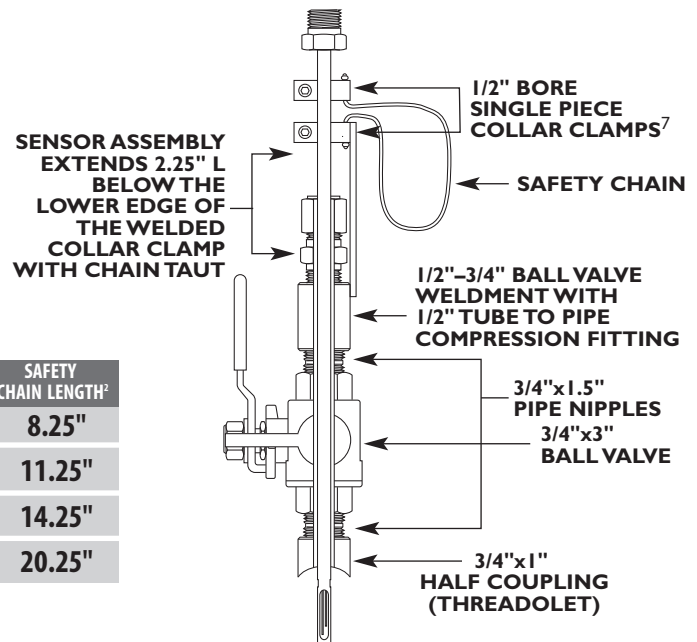

STCF SERIES TEFLON FERRULE COMPRESSION FITTING

1/2" tube x 1/2" pipe fitting (shown, not to scale), is used for low pressure insertion applications to 125 psig (Stainless Steel Ferrule optional for higher pressure applications – up to 225 psig). Also available in 3/4" tube x 3/4" pipe size.

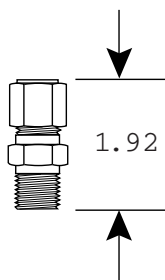

- At 250 psig, force exerted on 1/2" diameter probe is 50 lbs
- Safety chain is designed to prevent probe from accidentally escaping from assembly during removal from pressurized pipe
- Insertion meters can have optional flanged mounting (generally used for high pressure or very hot gases). This adaptation is not shown. Consult factory for details.
- Maximum gas temperature, 200F, unless high temperature models ordered.
- Hot Tapping is feasible by removing Weldment (upper portion of assembly temporarily removed)
- See page 46. SVA05 can be utilized for Sensor Functionality and Zero Self Check.
- The allen wrench for SVA05 is 3/16" (it is 5/16" for SVA07).

REV. 16-LIA/LRA

MOUNTING PLATE FOR THIN WALLED DUCTS (INCLUDES STCF05 COMPRESSION FITTING)

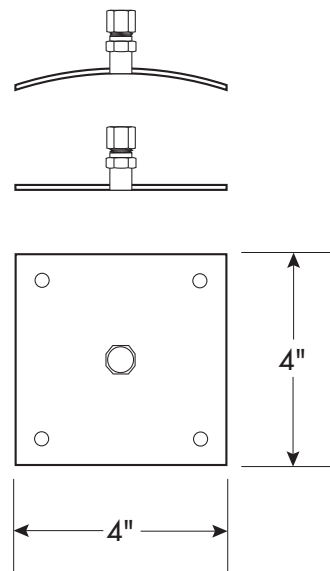

SVA05LP Low Pressure Isolation Valve Assembly

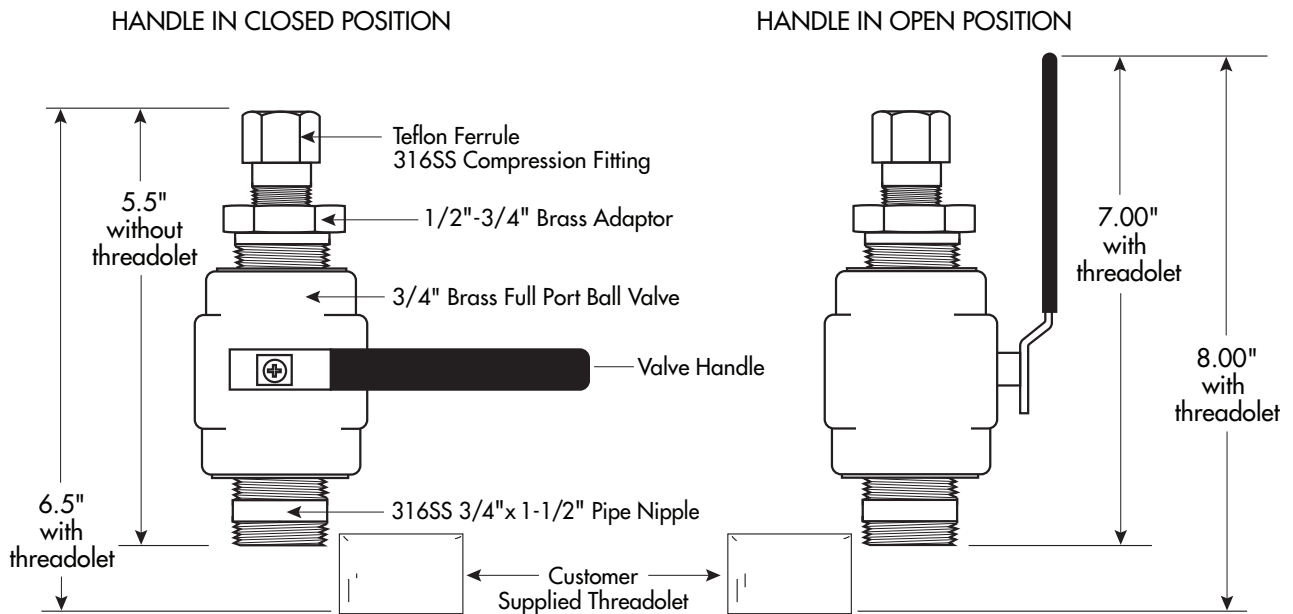

NOTES AND CAUTIONS

- Suitable for low pressure Air or Natural Gas applications (maximum 50 PSIG)
- Assumes 1/2" Insertion Probe inserted to center of a Pipe (see LANDTEC Probe Insertion Guidelines)
- Teflon Ferrule permits ease of Probe insertion or removal
- Exercise caution when loosening Ferrule nut during insertion and removal of Probe, since this model has no Safety Chain
- Note, maximum upward force is 20% of pipe pressure (i.e., 10 Lbs with 50 PSIG)
- The Assembly will be shipped with a plastic sleeve that protects the 3/4" pipe nipple
- It is the Customer's responsibility to weld a Female Threadolet with correct diameter to pipe

Flanged Ends for In-Line Meter (OPTIONAL)

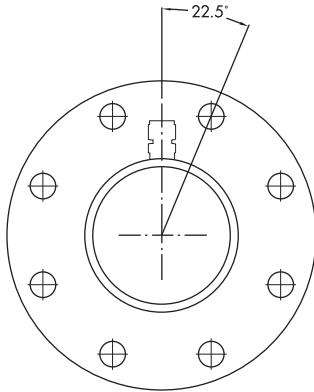

Flanges for 3½" pipe sizes and up, have 8 bolt holes

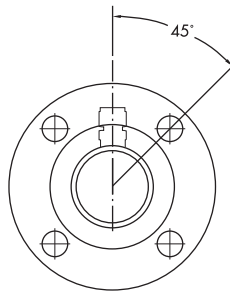

Flanges for 3" pipe sizes and smaller have 4 bolt holes

Flanged Mounting for Insertion Meter (OPTIONAL)

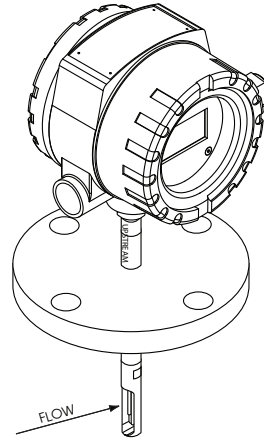

Section

D

DIAGNOSTICS

Common Diagnostics

SYMPTOM: Display failure, or pixels extremely dim.

CORRECTIVE ACTION: Contact Factory. Certain types of failures are under long term warranty. Please note that the 4-20 mA will still function normally.

SYMPTOM: Display fading, or partially fading.

CORRECTIVE ACTION:

- a) Some fading, particularly with those characters that are lit up most frequently, is normal. The flow meter will continue to function properly, and flow meter accuracy and outputs will not be effected.
- b) In extreme cases, contact the factory for display replacement.
- c) Note, in late 2009, the LANDTEC ACCU-FLO was modified to incorporate a built-in photocell. The purpose of the photocell is to adjust the display brightness with ambient lighting. The brighter the surrounding lighting conditions, the brighter the display. Lower ambient lighting conditions, such as a factory environment, will dim the display. The display will be dimmest if operated in low ambient lighting, or at night. The photocell circuit is designed to extend the life of the display, and to minimize fading.
- d) Note, in early 2010, a further enhancement was added to further extend the life of the display. The above mentioned built-in photocell also senses motion which automatically switches display from Screen Saver mode to Normal mode.

SYMPTOM: Erratic Readings.

POSSIBLE CAUSES: If a large Motor or Generator or Variable Frequency Drive (VFD) is nearby the enclosure, it may be inducing sufficient analog noise into the circuitry to temporarily corrupt the data.

SUGGESTED CORRECTIVE ACTION:

- a) If a Power-Restart temporarily solves the problem, than it is likely that the source of the noise was the problem.
- b) To prevent subsequent problems, if a Remote Style Meter, move the enclosure as far away as possible from the source (the Motor or VFD).
- c) If an Integral Style Meter, mount the meter in a different location (further from the source) or move the source further from the meter.

SYMPTOM: Erratic Readings on a Remote Meter.

POSSIBLE CAUSE: In some cases, analog noise is induced into the Remote cable causing erratic, or climbing readings.

SUGGESTED CORRECTIVE ACTION:

- a) Be sure the remote cable is installed in metal conduit and grounded on one end (in some cases, grounding both ends may be required).
- b) Also, avoid coiled cable, especially if not in metal conduit.

- c) Also, if extra cable exists, move the extra cable as far away as possible from any source of analog noise, such as large motors or VFDs.

SYMPTOM: Meter reading zero continuously, or Full Scale continuously, or temperature reading is abnormally low (hundreds of degrees below zero).

POSSIBLE CAUSES/SUGGESTED CORRECTIVE ACTION:

- a) It is likely that a wire is loose. But in rare cases, a sensor could fail (i.e., if a standard sensor, HT01 or HT02 sensor exceeds a process temperature of 450°F.)
 - b) Check for continuity to be sure the wiring is making good contact at the terminals of the Junction Box.
 - c) Also, to verify that the electronics and the sensor serial number are the same, note the following: The sensor's serial number will come up upon power up, right after Initializing on the Display. If the serial number doesn't agree with the Junction Box labels, that would affect calibration (in other words, sensors and electronics are a matched pair—mixing them up will cause false readings). Also metal Serial Number Tags are fastened to both the electronics and the Junction Box. They must have identical Serial numbers.
 - d) To check if a sensor has failed on a remote style meter, it is easy to use the Junction Box to do so. You must Power Down (shut off power), but you do not need to remove the probe from the pipe. Refer to page 24.
 - e) An Ohm Meter is required to check across the sensor leads of the Flow Sensor. Look at the drawing of the Junction Box. Disconnect the red wires on the Factory Side to isolate and measure the resistance. If the reading is infinity or a short, it means that sensor has failed.
 - f) Now check the Temperature Sensor. Disconnect the white wires on the Factory Side to isolate and measure the resistance. If you have infinity or a short, it means that sensor is burned out. Note: Normally the sensors will read approximately 110 ohms at 70° F. At higher temperatures they should read a higher resistance, but both sensors should have a similar value.
 - g) On integral style meters (LIA), there is no Junction Box. In that case, refer to the ACCU-FLO Integral Terminals on page 19 and check the sensor wires. Remove the appropriate wires first (red pair for flow, then white pair for temperature). Measure their resistance. If reading infinity or short, it means that sensor has failed.
- SYMPTOM:** Meter Railing (Pegging) or Reading High
- POSSIBLE CAUSES/SUGGESTED CORRECTIVE ACTION:**
- a) Insufficient straight run (i.e. flow profile is disturbed, causing errors).
 - b) Possible jet effect if upstream pipe is smaller than meter flow body or if valve is too close upstream to meter.

- c) Not following Probe Insertion Guideline.
- d) If sensor is inserted in reverse (“Upstream” mark is facing downstream) Meter may over-report (or under-report) by as much as 30%.
- e) If sensor is not aligned properly, with “Upstream” mark facing upstream, a rotation greater than ± 5 degrees may cause change in reading (greater than ± 5 degrees and less than ± 20 degrees causes meter to over-report; a greater rotation actually blocks the sensor, and causes meter to under-report).
- f) A downstream valve too close to the meter (flow may be reflecting back).
- g) Possibly caused by water droplets condensing out of gas stream (which generally causes output to spike; but if droplets are near continuous, output may rail).
- h) Meter is miswired, especially in Remote Style application.
- i) Possibly caused by water droplets condensing on inside of pipe wall, which roll down or hit sensor causing output to spike; but if droplets are near continuous, output may rail. Note: Recommend installation 45° from vertical (see drawing on page 68).
- j) Possibly caused by water droplets condensing out of gas stream and filling the cavity containing the sensing elements (usually due to probes mounted below horizontal in saturated pipes).
- k) Sensor may be contaminated. Remove probe, wipe off or clean with a solvent. Reinsert.
- l) Using a different gas or gas mix than the meter was specified and calibrated for.
- m) If a Remote Style Meter (LRA), be sure Serial Numbers of Junction Box and Remote Electronics are identical (if not, errors in calibration are inevitable). To confirm, verify that Junction Box Serial Number Tag has identical Serial Numbers to Tag on Remote Enclosure.
- n) Meter may appear to be reading high if user is comparing LANDTEC flow meter readings (SCFM) to an uncorrected volumetric device (ACFM). For example, at constant volume, a decrease in gas temperature will increase the mass flow (SCFM). That is completely normal.

SYMPTOM: Reading Low

POSSIBLE CAUSES:

- a) Insufficient straight run (i.e. flow profile is disturbed, causing errors).
- b) Poor flow profile Upstream (insufficient upstream straight run).

- c) Not following Probe Insertion Guideline.
- d) If sensor is inserted in reverse (“Upstream” mark is facing downstream) Meter may over-report (or under-report) by as much as 30%.
- e) If sensor is not aligned properly, with “Upstream” mark facing upstream, a rotation greater than ± 5 degrees may cause change in reading (greater than ± 5 degrees and less than ± 20 degrees causes meter to over-report; a greater rotation actually blocks the sensor, and causes meter to under-report).
- f) Sensor may be contaminated. Remove probe, wipe off or clean with a solvent. Reinsert.
- g) Using a different gas or gas mix than the meter was specified and calibrated for.
- h) If a Remote style Meter (LRA), be sure Serial Numbers of Junction Box and Remote Electronics are identical (if not, errors in calibration are inevitable). To confirm, verify that Junction Box Serial Number Tag has identical Serial Numbers to Tag on Remote Enclosure.
- i) Meter may appear to be reading low if user is comparing LANDTEC flow meter readings (SCFM) to an uncorrected volumetric device (ACFM). For example, at constant volume, an increase in gas temperature will lower the mass flow (SCFM). That is completely normal.
- j) On most models, the Totalizer will not start count-ing for 10 seconds after power up so any flow data will not be accumulated during this time.
- k) Insufficient power supply—most products require minimum 100 mA.
- l) Excessive load on the 4-20 mA. (To check if problem is due to 4-20 mA output device, temporarily remove device, and observe if display reads as expected).

SYMPTOM: Totalizer can take up to 10 seconds to update its reading when flow meter is first powered up, or a channel is changed.

CORRECTIVE ACTION: None. This slight delay is completely normal.

SYMPTOM: Display does not have power

POSSIBLE CAUSE: Mis-wiring

SYMPTOM: 4-20 mA output not tracking the flow rate display

POSSIBLE CAUSE:

- a) In normal operation (Self Powered) B4 and B5 must be jumpered to supply power to loop. See pages 19 and 22.
- b) In Externally Powered mode, the jumper must be removed. Verify that 9 to 27 Volts DC is supplied to externally power the loop as per page 19 or 22.

In-Situ Calibration Check

RECOMMENDED ON A QUARTERLY BASIS FOR EPA 40 CFR 98 PERIODIC CALIBRATION VERIFICATION, CAR¹ PROTOCOLS, AND CDM² PROTOCOLS

LANDTEC ACCU-FLO has continuous diagnostics. The raw calibration milliwatts (mw) is always displayed in the upper left hand corner of the meter's display allowing the user to conduct an "in-situ" calibration. At any time, you can check this reading at a "no flow" condition and compare the reading to the original reported "zero flow" value noted on the last few lines of your meter's Certificate of Conformance or the flow meter's data tag. This diagnostic procedure not only checks the sensor performance and the "live zero" calibration point, but it verifies that the sensor is clean. It essentially provides a means to validate that the meter is operating properly, verifies that there is no shift or drift, and eliminates the need for annual factory calibrations. This simple field diagnostic procedure also verifies that the sensor is free from contamination, even without inspection.

1. Verify that meter has no gas flow³

Close appropriate valves in the process to have a "no flow" condition so you can check the "live zero" mw output of the actual gas (it should be checked at the same pressure as noted on Certificate of Conformance).

If it is not possible to close valves in the process (e.g. natural gas supply must be kept flowing), a user with a LANDTEC SVA05 or SVA07 Isolation Valve Assembly can check "zero" of the actual gas and pressure without shutting off the gas supply.

Refer to SVA SERIES ISOLATION VALVE ASSEMBLY DETAILS ON PAGE 38.

- Loosen lower Collar Clamp completely⁴
- Slightly loosen compression fitting until Probe can be lifted
- Lift Probe until Safety Chain is taut
- Tighten compression fitting
- Close Valve
- Check zero mw as per "2" below

Optionally, do an ambient air check by removing probe and covering up sensor by capping the sensor with a plastic bag, empty plastic water bottle or other means of preventing flow (see 8).

- Observe the raw mw on the top of the meter's display. After one to three minutes of "no flow" stabilization, check the observed reading against the flow meter's data tag or last line(s) of your Meter's Certificate of Conformance.
- A value within 5 milliwatts of the original Factory value (assuming the same gas is checked at same pressure) indicates that meter is still in calibration.
- A value greater than 5 mw, but less than or equal to 10 mw, also indicates that the meter is still in calibration, but this reading may have been influenced by one or more of the following factors: gas composition, pressure, dirt, non-zero conditions, and sensor orientation. Any of these

factors can have an effect on mWo. It is a very sensitive data point; that is why it is such a good check.

- Note, if all of the above factors were remedied, it would be expected that the mW zero would report less than or equal to 5 milliwatts.
- Note, in some cases, contamination of the sensor is the only cause of the additional heat transfer during the "no flow" test. Remove probe, and clean the sensor (use an appropriate non-corrosive solvent to remove build up). A soft brush can be used to gently clean the sensing surface, using caution to avoid damaging the sensor elements (the RTD's).
- In summary, if a technician in the field were able to simulate LANDTEC calibration conditions, he too would find that the mWo would be within one mW or very close to that. Since this is not always possible, we are finding that after considering all of the field variables, a mWo in the field that is within 10 mW is an acceptable value (see 9). This would allow for a check to be done in the pipe under application conditions.
- Note, if desired, a second check can be conducted as well but using ambient air: This validation method requires that the sensor be removed from the pipe and inserted in a container such as an empty plastic water bottle.
- For CAR¹ compliance LANDTEC recommends a quarterly In-Situ Calibration Check for the following Protocols:
 - U.S. Landfill Protocol, Version 4.0, Par. 6.2*
 - Mexico Landfill Protocol, Version 1.1, Par. 6.2*
 - U.S. Livestock Protocol, Version 3.0, Par. 6.2*
 - U.S. Livestock Protocol, Version 4.0, Par. 6.3*
 - Mexico Livestock Protocol, Version 2.0, Par. 6.2*
 As per the protocols, the maximum allowable drift is 5%. Percent drift can be determined by multiplying the mW change from factory value (see 2) by 1.0% (i.e. each mW change equals 1% drift).

¹ CAR is the Climate Action Reserve. The Climate Action Reserve is a national offsets program working to ensure integrity, transparency and financial value in the U.S. carbon market. It does this by establishing regulatory-quality standards for the development, quantification and verification of greenhouse gas (GHG) emissions reduction projects in North America. The Climate Action Reserve operates alongside its sister program, the California Climate Action Registry (California Registry), which was created by the State of California in 2001 to address climate change through voluntary calculation and public reporting of emissions.

² CDM Methodologies, ACM 0001, "Methodological tool to determine the mass flow of a greenhouse gas in gaseous stream" (EB61 Report, Annex 11, Page 1).

³ LANDTEC "zeros" the meter in a horizontal pipe. If you have a vertical pipe, mW will be slightly lower at zero (also see note 4).

⁴ The allen wrench to loosen collar clamp is $\frac{1}{8}$ " on the SVA05 (it is $\frac{3}{16}$ " on the SVA07).

Section

E

**WARRANTIES AND
SERVICE WORK**

Warranties and Service Work

LIMITED WARRANTY

LANDTEC products are warranted against faulty materials or workmanship for one year from the date of shipment from the factory. LANDTEC's obligation is limited to repair, or at its sole option, replacement of products and components which, upon verification by LANDTEC at our factory in Colton, California, prove to be defective. LANDTEC shall not be liable for installation charges, for expenses of Buyer for repairs or replacement, for damages from delay or loss of use, or other indirect or consequential damages of any kind. This warranty is extended only to LANDTEC products properly used and properly installed for the particular application for which intended and quoted; and does not cover water damage due to improper use of cord grips or removal of protective caps; and does not cover LANDTEC products which have been altered without LANDTEC authorization or which have been subjected to unusual physical or electrical stress. LANDTEC makes no other warranty, express or implied, and assumes no liability that goods sold to any purchaser are fit for any particular purpose. Transportation charges for materials shipped to the factory for warranty repair are to be paid by the shipper. LANDTEC will return items repaired or replaced under warranty, prepaid. NOTE: No items will be returned for warranty repair without prior written authorization from LANDTEC. LANDTEC does not warranty damage due to corrosion.

GENERAL TERMS AND CONDITIONS

Detailed General Terms and Conditions can be found on the LANDTEC website (WWW.LANDTECNA.COM).

CANCELLATION / RETURN POLICY

Cancellation or Return: After issuance of a purchase order (by phone, mail, e-mail or fax) or a credit card order (by phone, mail, e-mail or fax), there will be a cancellation fee for any cancelled order. Cancellations must be in writing (by mail, e-mail or fax):

- 1) If credit card order or non-credit card order is cancelled within 7 days of issuance of purchase order or date order was placed (which ever is earlier), there will be a 10% cancellation fee.
- 2) If credit card order or non-credit card order is cancelled after 7 days, but prior to shipment, there will be a 20% cancellation fee. (If order is cancelled due to late delivery, the cancellation fee will be waived. Late delivery is defined as shipping a meter 7 days or later than the delivery date acknowledged by LANDTEC at time of placing order).
- 3) If a credit card customer decides to return the equipment after shipment for credit, credit will not be issued if equipment is damaged or if equipment is returned after four (4) months of shipment. If equipment is not damaged, then equipment can be returned after issuance of a Return Meter Authorization (RMA) by LANDTEC. **Returned package must be insured by customer and must reference proper RMA# on outside of package**, or package may be rejected (i.e., package will be returned unopened). Credit Card customers will be charged a 30% re-stocking fee (70% balance will be credited back). Customer is responsible for return shipping charges and any damage if improperly packaged.

continued on next page

- 4) If a non-credit card customer decides to return the equipment after shipment for credit, credit will not be issued if equipment is damaged or if equipment is returned after 1 month of shipment, unless authorized by a representative at LANDTEC. The LANDTEC representative will issue a Return Material Authorization (RMA) at that time and will advise of the restocking fee. **Returned package must be insured by customer and must reference proper RMA# on outside of package**, or package may be rejected (i.e., package will be returned unopened). Customer is responsible for return shipping charges and any damage if improperly packaged.

RETURNING YOUR LANDTEC METER

A Return Material Authorization Number (RMA#) must be obtained prior to returning any equipment to LANDTEC for any reason. RMA#s may be obtained by calling LANDTEC at 800-LANDTEC or 909-783-3636 between 8:00 am and 5:00 pm Monday through Friday.

A LANDTEC RMA Form (see page 52) must be filled out and included with the meter being returned to LANDTEC.

Take special care when packaging your meter for return to the factory. The sensor in particular may easily be damaged if not prevented from shifting around within the package and if the sensor itself is not covered to keep it from contacting other package contents. Any damage resulting from improper packaging is the responsibility of the shipper.

A purchase order is required prior to an RMA being issued. Most repairs or recalibrations can be quoted over the phone. For equipment that must be evaluated, an Evaluation purchase order in the amount of \$150 is required. Once an evaluation is completed and a quote has been issued, you can choose to proceed with the work or have the unit returned with only the evaluation and freight fee billed.

In accordance with the "Right to Know Act" and applicable US Department of Transportation (DOT) regulations, LANDTEC will not accept delivery of equipment that has been contaminated without written evidence of decontamination, and has instituted the following Return/Repair conditions. Strict adherence to these conditions is required. Returned equipment that does not conform to the requirements listed below will not be processed. If LANDTEC finds evidence of contamination, we may, at our option, have the unit returned at your expense. For your reference, the requirements for packaging and labeling hazardous substances are listed in DOT regulations 49 CFR 172, 178, and 179.

1. The equipment must be completely cleaned and decontaminated prior to shipment to LANDTEC. This decontamination includes the sensor, probe, electronics and enclosures internally and externally. All packaging must be clean and free from contamination.
2. A Material Safety Data Sheet (MSDS) is required for all process fluids and gases that have been in contact with the equipment. This includes fluids or gases used in cleaning the equipment. A Decontamination Statement is also required for each meter returned using a different gas or fluid. Both the MSDS and the Decontamination Statement are to be attached to the OUTSIDE of the shipping container. If both documents are not attached, you will be called, and the equipment sent back to you at your expense.
3. The decontamination Statement must include the following required information
 - A. A list of all chemicals and process fluids used in the equipment, including decontamination fluids or gases.
 - B. The model and serial number of the equipment being returned.
 - C. A company officer or other authorized person's signature on the statement.

Return Shipping Address:

**LANDTEC NORTH AMERICA
850 SOUTH VIA LATA, SUITE 112
COLTON, CA 92324**

RETURN MATERIAL AUTHORIZATION

RMA # _____

Date _____

RETURN CUSTOMER INFORMATION

Customer's Name _____ Fax # _____

Customer's Contact Name _____ Phone # _____

Email Address _____

CUSTOMER'S RETURN ADDRESS

Bill to: _____ Ship to: _____

RETURN PRODUCT INFORMATION

Model No. _____ Serial No(s). _____

FLOW: MIN _____ NORMAL _____ MAX _____

TEMP: MIN _____ NORMAL _____ MAX _____

PRESSURE: MIN _____ NORMAL _____ MAX _____

GAS _____ LINE SIZE _____

REASON FOR RETURN / DESCRIPTION OF SYMPTOMS

(All non-warranty repairs could be subject to a minimum evaluation charge)

Recommended steps to be used to duplicate problem/symptoms _____

LANDTEC Technical Contact _____

Take special care when packaging your meter for return to the factory. The sensor in particular may easily be damaged if not prevented from shifting around within the package and if the sensor itself is not covered to keep it from contacting other package contents. Any damage resulting from improper packaging is the responsibility of the shipper.

LANDTEC NORTH AMERICA
850 SOUTH VIA LATA, SUITE 112 / COLTON, CALIFORNIA 92324
PHONE: 800-LANDTEC / FAX: 909-825-0591

Section

F

MODBUS

Modbus Register Listing

LANDTEC ACCU-FLO REV. 1.80–2.07

UINT32		IEEE Float		SCALED INT32*		Reg Description
Reg Offset	Reg Offset	Type	Reg Offset	Type		
256		UINT8				format flag
256		UINT8				modbus_unit_id
257		UINT8				output mode sel
257		UINT8				fix_pt selection
257		UINT1				bRun
257		UINT1				bTotal
257		UINT1				bEEProm
257		UINT1				bReset
257		UINT1				bLeadEn
257		UINT1				bDAClo
257		UINT1				bDACHi
	514	FLOAT	770	LONG		CAL_VAL
	516	FLOAT	772	LONG		K-FACTOR
	518	FLOAT	774	LONG		VREF
	520	FLOAT	776	LONG		LOAD-RES
TEMP	522	FLOAT	778	LONG		COEFF A
TEMP	524	FLOAT	780	LONG		COEFF B
TEMP	526	FLOAT	782	LONG		COEFF C
TEMP	528	FLOAT	784	LONG		COEFF D
	530	FLOAT	786	LONG		DISP A
	532	FLOAT	788	LONG		DISP B
	534	FLOAT	790	LONG		DISP C
	536	FLOAT	792	LONG		DISP D
FLOW	538	FLOAT	794	LONG		COEFF A
FLOW	540	FLOAT	796	LONG		COEFF B
FLOW	542	FLOAT	798	LONG		COEFF C
FLOW	544	FLOAT	800	LONG		COEFF D
FLOW	546	FLOAT	802	LONG		COEFF E
FLOW	548	FLOAT	804	LONG		COEFF F

UINT32		IEEE Float		SCALED INT32*		Reg Description
Reg Offset	Reg Offset	Type	Reg Offset	Type		
	550	FLOAT	806			iir filter coeff
	552	FLOAT	808			flow_min
	554	FLOAT	810			flow_max
	556	FLOAT	812			PULSE COUNT
	558	FLOAT	814			temp_max
302		UINT16				dac1_min
304		UINT16				dac1_max
306		UINT32				serial number
308		ASCII				RATE string
310		ASCII				TOTAL string
312		UINT32				current totalizer
314		UINT32				ADC0
316		UINT32				ADC1
318		UINT32				ADC2
320		UINT32				ADC3
	578	FLOAT	834	LONG		current flow
	580	FLOAT	836	LONG		current temp
	582	FLOAT	838	LONG		rtd_mWatts
	584	FLOAT	840	LONG		rtd_res
	586	FLOAT	842	LONG		ref_res_r
	588	FLOAT	844	LONG		ref_res_d
	590	FLOAT	846	LONG		dac_smooth
	592	FLOAT	848	LONG		lead
	594	FLOAT	850	LONG		oheat
	596	FLOAT	852	LONG		bv
	598	FLOAT	854	LONG		fv
	600	FLOAT	856	LONG		tv
	602	FLOAT	858	LONG		lv

*SCALED INT32 register contents form INT32 values by multiplying the IEEE FLOAT x 1000
 ex. FLOAT -> 112.768 = SCALED INT32 -> 112768

LANDTEC Modbus Protocol Rev. 1.80–Rev. 2.07

LANDTEC ACCU-FLO Meters support communication with other devices via MODBUS® protocol using RTU transmission mode. The Modbus protocol defines a message structure that controllers will recognize and use, regardless of the type of networks over which they communicate. It establishes a common format for the layout and contents of message fields. Transactions use a master-slave technique, in which only one device (the master) can initiate transactions (called queries). The other devices (the slaves) respond by supplying the requested data to the master and by taking the action requested in the query. LANDTEC Meters operate as slaves to other Modbus devices and default to 19200-8-E-1, however, the following modes may also be software selectable:

9600-8-N-1	(Baud-Bits-Parity-Stop)
9600-8-E-1	
9600-8-O-1	
19200-8-N-1 ¹	
19200-8-E-1	(Default)
19200-8-O-1	

MESSAGE FRAMING

Messages start with a silent interval of at least 3.5 character times followed by 4 fields and then followed by another silent interval of at least 3.5 character times. The first field contains the device address. The second field contains the function code. The third field contains the data and byte counts. The fourth field contains the CRC value.

ADDRESS FIELD

The address field contains one byte. LANDTEC ACCU-FLO Meters will transmit response packets to addresses which are between 1 to 240 decimal (inclusive). Modbus packet writes may be sent to broadcast address 00, however the ACCU-FLO will not reply with a response packet.

FUNCTION CODE FIELD

The function code field contains one byte. See the section titled *Function Codes Supported by LANDTEC ACCU-FLO*.

DATA FIELD

The data field contains four or more bytes. This information is used by the Meter to take the action defined by the function code, or to read or write data to one or many registers.

CRC FIELD

The CRC-16 (cyclical redundancy check) field is two bytes, containing a 16-bit binary value. The CRC value is calculated by the transmitting device, which appends the CRC to the message. The receiving device recalculates a CRC during receipt of the message, and compares the calculated value to the actual value it received in the CRC field. If the two values are not equal, the message will be discarded.

¹ Parity on the Wireless Devices manufactured by Obvius is "None" rather than "Even". The LANDTEC default is 19200-8-E-1. Change to 19200-8-N-1 for the Obvius Modhoppers and related wireless devices.

Function Codes Supported by LANDTEC ACCU-FLO

03 (0X03) READ HOLDING REGISTERS

Identical operation as code 04 READ INPUT REGISTERS described below, except READ only.

04 (0X04) READ INPUT REGISTERS

Reads the binary contents of the specified register. This is READ/WRITE register. LANDTEC ACCU-FLO values are typically 32 bits wide (4 bytes) and contain a single IEEE754 floating point value. Modbus registers are 16 bits wide (2 bytes) so a minimum of 2 Modbus registers are required to transfer all floating point bits to the master. See section titled LANDTEC Floating Point Format.

Query

The query message specifies the starting register address and the quantity of registers to be read.

0x03 READ MULTIPLE HOLDING REGISTERS or
0x04 READ MULTIPLE INPUT REGISTERS

-QUERY-	-RESPONSE-
SA - SLAVE ADDRESS	SA
04 - FUNC CODE	04
RH - REG ADDR HI	BC - # of data bytes to follow
RL - REG ADDR LO	DATA0
00 - # OF REGS HI	DATA1
CT - # OF REGS LO	DATAn
CH - CRC MSB	CH CRC MSB
CL - CRC LSB	CL CRC LSB

REG ADDR HI (RH) is set to:
01 for INTEGER access of integral values
02 for IEEE754 floating point
03 for Scaled (x1000) long integer of floating point value

REG ADDR LO (RL) is the starting address index into the register structure. See section titled LANDTEC Register Index Values.

CT is the register count needed to transfer data. Typically this byte is set to 02 to request 1 full IEEE754 floating point value. (Modbus single registers are 16 bits wide, LANDTEC floating point values are 32 bits wide.)

DATA0-DATAn are bytes in binary format returned from the slave device representing the contents of the selected register(s).

NOTE: values indicated with 0x prefix are in hexadecimal, otherwise in decimal notation.

16 (0x10) WRITE REGISTERS

Writes the binary contents of the specified register into the meter. LANDTEC ACCU-FLO values are typically 32 bits wide (4 bytes) and contain a single IEEE754 floating point value. Modbus registers are 16 bits wide (2 bytes) so a minimum of 2 Modbus registers are required to transfer all floating point bits into the meter. See section titled LANDTEC Floating Point Format.

Query

The query message specifies the starting register address and the quantity of registers to be written.

16 (0x10) WRITE MULTIPLE REGISTERS

-QUERY-	-RESPONSE-
SA - SLAVE ADDRESS	SA
0x10 - FUNC CODE	0x10 - 16 FUNC CODE
RH - REG ADDR HI	RH - REG ADDR HI
RL - REG ADDR LO	RL - REG ADDR LO
00 - # OF REGS HI	00 - # REGS HI
CT - # OF REGS LO	CT - # REGS LO
BC - BYTES COUNT	CH - CRC MSB
DATA0	CL - CRC LSB
DATA1	
DATAn	
CH - CRC MSB	
CL - CRC LSB	

REG ADDR HI (RH) is set to:
01 for INTEGER access of integral values
02 for IEEE754 floating point
03 for Scaled (x1000) long integer of floating point value

REG ADDR LO (RL) is the starting address index into the register structure. See section titled LANDTEC Register Index Values.

CT is the register count needed to transfer data. Typically this byte is set to 02 to request 1 full IEEE754 floating point value.

BC is the actual number of bytes that follow.

DATA0-DATAn are bytes in binary format transmitted to the slave device representing the contents of the selected register(s).

NOTE: THIS PAGE APPLIES TO REV. 1.81–1.83**17 (0x11) REPORT SLAVE IDENTIFICATION***

This query requests from the specified slave address a detailed identification packet with a run status, and LANDTEC ACCU-FLO and firmware revision response. (ACCU-FLO will not respond to broadcast slave address 00.)

Query

The query message specifies the slave address, function code, and CRC check words.

17 (0x11) REPORT SLAVE ID

–QUERY–	–RESPONSE–
SA – SLAVE ADDRESS	SA
11 – FUNC CODE	11
CL – CRC LSB	BC – BYTES COUNT, 19
CH – CRC MSB	SD – SLAVE ID (DEVICE SPECIFIC), 0x5A
	RS – RUN STATUS INDICATOR, 0xFF
	ASCII Text – LANDTEC ACCU-FLO v1.81x
	CH
	CL

Response

The LANDTEC ACCU-FLO will respond with an echo of the slave address and function code. The byte count will be 19 (0x13) to allow the master to account for all the remaining bytes that follow.

REPORT SLAVE ID Example: (Slave Address = 0x30 = 48, default)

Master Query → 30 11 D5 BC

ACCU-FLO Response → 30 11 13 5A FF 53 61 67
65 20 50 72 69 6D 65 20

76 31 2E 38 31 20 F1 2B

ASCII translation→ LANDTEC ACCU-FLO v1.81

ILLEGAL FUNCTION CODES*

The LANDTEC ACCU-FLO will respond to other Modbus function codes not documented in this revision, these codes are considered unsupported by LANDTEC. Unsupported function codes will cause the ACCU-FLO to reply with Modbus ILLEGAL FUNCTION status.

LANDTEC REGISTER INDEX VALUES

DATA TYPE	VALUE	SIZE	INDEX	ADDRESS DESCRIPTION
Byte	slave_ad	1 BYTE	1	Modbus Slave Address*
float	flow_rate;	1 IEEE754	578	actual flow rate
float	flow_temp;	1 IEEE754	580	process temperature
float	rtd_mWatts;	1 IEEE754	582	sensor power reading
float	rtd_res;	1 IEEE754	584	actual sensor probe resistance
float	ref_res_r;	1 IEEE754	586	actual temperature probe resistance
integ	totalizer;	1 uLONG	312	actual displayed total

*NOTE: LANDTEC ACCU-FLO Meters are factory programmed with the MODBUS slave address = 48 (0x30). It may be extremely useful to be able to write to an unknown slave address with a simple broadcast command. Be sure only one LANDTEC ACCU-FLO is connected during any broadcast writes using slave address = 0.

Writing into unspecified registers (not defined above) can render the unit non-functional or overwrite factory calibration data yielding incorrect operation.

EXAMPLE MODBUS PACKET**Query**

This packet will request of the addressed slave to respond by sending back the contents of registers 578 to 582 (inclusive). Three registers: flow rate through RTD mWatts in IEEE754 floating point format.

0x31 – LANDTEC ACCU-FLO SLAVE ADDRESS (0x31 Hex = 49 Decimal default)
0x04 – READ INPUT REGS FUNCTION CODE
0x02 – STARTING REGISTER HI BYTE (0x01 = 256, 0x02 = 512, 0x03 = 768)
0x42 – STARTING REGISTER LO BYTE (512 + 66 = register access = 578)
0x00 – COUNT MSB (ALWAYS ZERO)
0x06 – COUNT OF ALL DESIRED REGISTERS
0xD5 – CRC HI BYTE
0x85 – CRC LO BYTE

*Not implemented in revision 1.80

LANDTEC Register Output Format

INTEGER REPRESENTATION

Computer systems hosting a MODBUS network typically store integer values to represent non-fractional quantities.

All registers addressed above 256 (0x0100-0x1FF) will transfer 16 bit integral quantities in response to all master queries. MODBUS requires that the register count reflects each 16 bit registers transmitted to ensure that no bytes are missing in the transfer of integer quantities. (Note: Most LANDTEC ACCU-FLO registers are IEEE754 quantities; integer representations of these registers will require significant translation.)

IEEE754 FLOATING POINT

Computer systems hosting a MODBUS network typically store single precision floating point data in the standard IEEE754 format.

All registers addressed above 512 (0x0200-0x02FF) will transfer full 32 bit single precision quantities in response to all master queries. MODBUS requires that two 16 bit registers are transmitted to ensure that no bytes are missing in the transmission of 32 bit quantities.

SCALED DECIMAL REPRESENTATION

Computer systems hosting a MODBUS network may choose represent single precision floating point values as scaled long integers (32 bit values). The LANDTEC ACCU-FLO will convert floating point registers to integral units by multiplying the value by 1000.

Ex. Floating point value 1234.567 will be converted to integral value 1234567

All registers addressed above 768 (0x0300-0x03FF) will transfer full 32 bit scaled integer quantities in response to all

master queries. MODBUS requires that two 16 bit registers are transmitted to ensure that no bytes are missing in the transmission of 32 bit quantities.

For more information on the MODBUS protocol, see: <http://www.modbus.org/tech.php>

LANDTEC ADDRESSER SOFTWARE

Addresser is a convenient software kit that includes Addresser software, as well as an optically isolated ULINX RS485 to USB converter. The Addresser is a READ/WRITE Program with drop-down menus for convenient user interface between your PC or laptop and the Modbus Terminals of the LANDTEC ACCU-FLO. Contact LANDTEC for ordering information and instructions.

LANDTEC Addresser Typical Printout (Version 3.14)

SMB Printout
Serial# 50043

Units: SCFM Modbus:
0x31

6/23/2011
12:01:50 PM

Parameter	Decimal Data	Hex Format
Calib mW Val	44.91799	8433AC08
K-Factor	1.000000	7F000000
Lead Gain Val	0.992098	7E7DFA22
Flow Load Res	20.10000	8320CCCD
Temp Calib[A]	-3.07714	80C4F000
Temp Calib[B]	1.144714	7F128600
Temp Calib[C]	-0.00121	759F7000
Temp Calib[D]	0.000003	6C3F3400
Temp Disp Null	0.000000	00000000
Temp Disp Gain	1.000000	7F000000
Amp Null Val	-0.16634	7CAA56DE
Amp Gain Val	1.008498	7F011676
Flow Coeff[A]	-20.7094	83A5ACF2
Flow Coeff[B]	0.720296	7E38654E
Flow Coeff[C]	-0.00880	789033FC
Flow Coeff[D]	0.000067	710D75E4
Flow Coeff[E]	0.000000	00000000
Flow Coeff[F]	0.000000	00000000
Filtering	0.500000	7E000000
Min Flow/LFC	0.000000	00000000
Full Scale	1200.000	89160000
Min Temp	40.00000	84200000
Units/Pulse	100.0000	85480000
DAC1 Min	725.0000	000002D5
DAC1 Max	3674.000	00000E5A
Serial Number	50043.00	0000C37B
Flow Units	12964504	4D464353
Total Units	11790099	46464353
Output Config	8.000000	00000008
Pulse Dur	250.0000	000000FA

Section

G

APPENDIX

LANDTEC ACCU-FLO Field Programmable “Dongle”

Although virtually any setting on LANDTEC ACCU-FLO can be changed by users who have Modbus® capability (see pages 19 and 22 for terminal connections), not all customers have that capability to communicate with the ACCU-FLO using its Modbus Compliant RS485 Communications. However, users do not need to have a Modbus host or any special skill, since they can also change configurations in the field by using the patent pending LANDTEC “Dongle”.

The LANDTEC ACCU-FLO device known as a “Dongle”, was developed to facilitate making changes on LANDTEC ACCU-FLO Flow Meter settings in the field. Simply contact LANDTEC and specify your requirement (such as the new Full Scale, new Pipe Area, etc), and the device will be programmed at LANDTEC and sent directly to you within a few days (there is a slight fee for this service). The patent-pending Dongle can also be configured as a Reset Totalizer device (i.e. it can be used repeatedly, with any LANDTEC ACCU-FLO to easily reset the Totalizer). The Dongle can also be programmed to change Engineering Units, Filter Response and numerous other parameters.

In fact, Dongles can also be used to provide multiple gas calibrations. In this case, the requirements must be specified at the time of ordering. For example, one meter can be calibrated for four different gases with totally different calibration ranges, by providing four Dongles with the Flow Meter. When a different gas calibration is needed, simply

upload the data from the appropriate Dongle. It only takes a few seconds to do so.

Dongles come with a convenient well marked cable that is connected to the RS485 terminals. Simply remove the rear cover, connect the Dongle, and push the button on the Dongle. An LED will illuminate, and within 3 seconds the light will go out signaling that the data transfer is complete.¹ Remove the Dongle, close the cover, and you will notice that the new settings have been uploaded (or in the case of a Totalizer-Reset Dongle, you will notice that the Totalizer has zeroed).



¹ If the light does not go out, it will be necessary to repeat procedure. Remove finger for a few seconds and then push button again.

Correction Factors For Variation From Original Digester Gas Calibration

LANDTEC can calibrate for any Digester Gas, Bio Gas or Landfill Gas Mix. However, it may be helpful to have correction factors for a typical calibration, in the event that the composition changes after delivery. The following examples assume that the initial calibration was set up for 60% CH₄ and 40% CO₂.

- a) 65% CH₄ and 35% CO₂: Multiply reading by 0.982 to correct it for new composition
 - b) 70% CH₄ and 30% CO₂: Multiply reading by 0.965 to correct it for new composition
 - c) 55% CH₄ and 45% CO₂: Multiply reading by 1.0185 to correct it for new composition
- For smaller changes, the corrections are linear in between
- d) Also, if 100% saturated with H₂O vapor (non-condensing), multiply readings by 1.042
 - e) If 50% saturated with water, multiply reading by 1.021 (Water vapor correction is linear in between)

Also, use the 45 degree mounting method in order to avoid droplets from hitting the sensor and causing spikes (see above right)

Installations Where Pipe Condensation May Develop

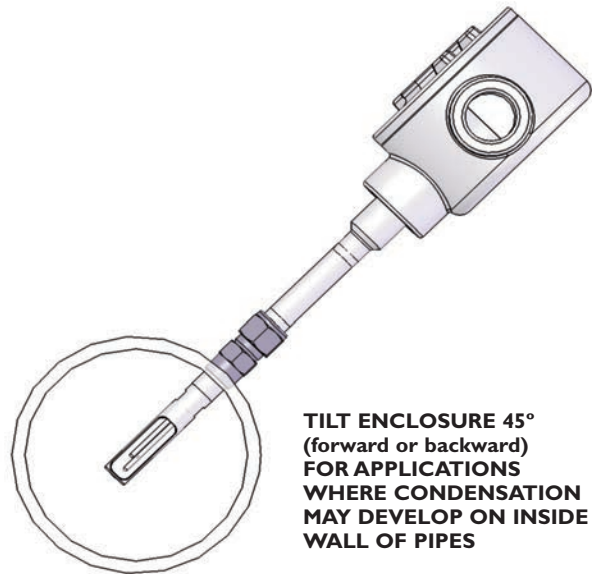

**TILT ENCLOSURE 45°
(forward or backward)
FOR APPLICATIONS
WHERE CONDENSATION
MAY DEVELOP ON INSIDE
WALL OF PIPES**

J-Box and Upstream Orientation

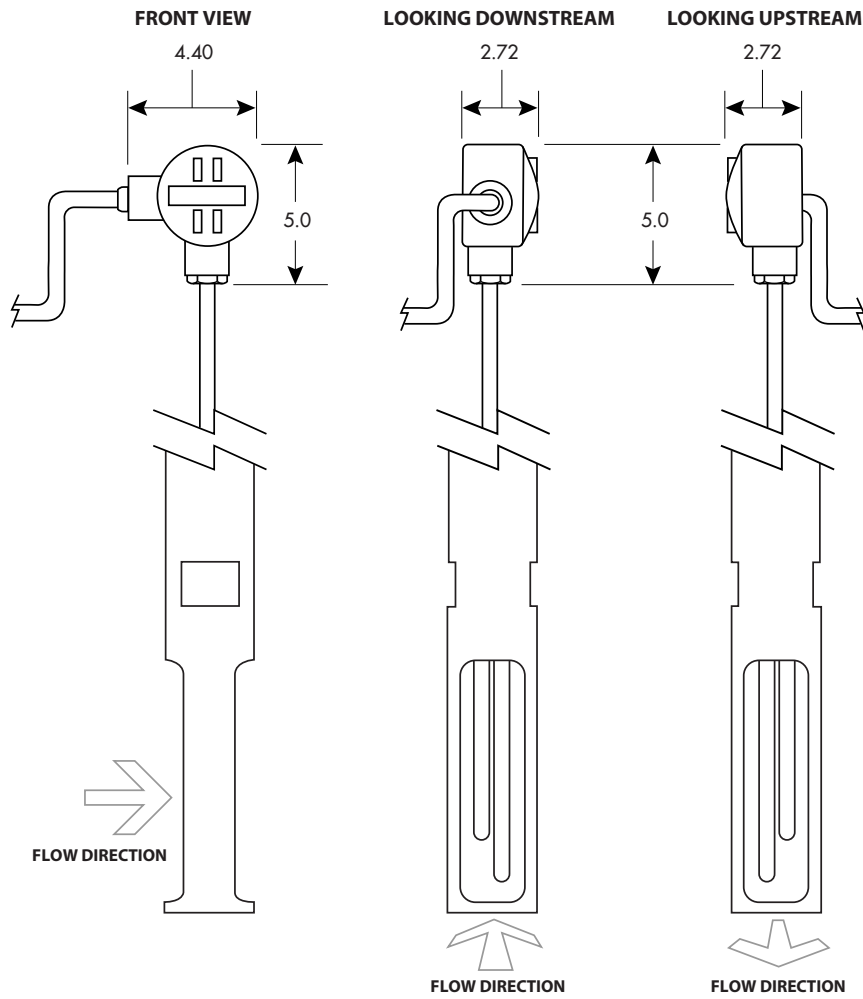

What is a Thermal Mass Flow Meter?

- What is a Thermal Mass Flow Meter? It is a meter that directly measures the gas mass flow based on the principle of conductive and convective heat transfer.
- All Meters have probes (Insertion Style) or Flow Bodies (In-Line Style) that support a pair of sensors, which are in contact with the gas.
- The sensors are RTDs, which are resistance temperature detectors. They consist of highly stable reference-grade platinum windings. In fact, we use the same material that is used as Platinum Resistance Standards at the NIST.
- The RTDs are clad in a protective 316 SS sheath for industrial environments.
- One of the RTDs [See Diagram below] is self-heated by the circuitry and serves as the flow sensor. The other RTD acts as a reference sensor, and measures the gas temperature. Essentially it is used for temperature compensation.
- The LANDTEC proprietary hybrid-digital sensor drive circuitry maintains a constant overheat between the flow sensor and the reference sensor. As gas flows by the heated sensor (flow sensor), the molecules of flowing gas carry heat away from this sensor, and the sensor cools down as it loses energy. The circuit equilibrium is disturbed, and momentarily the temperature difference between the heated sensor and the reference sensor has changed. The circuit will automatically (within 1 second) replace this lost energy by heating up the flow sensor so the overheat temperature is restored.
- The current required to maintain this overheat represents the mass flow signal. There is no need for external temperature or pressure devices.

