



Invacare® AVIVA™ FX

IFX-20R, IFX-20SP, IFX-20MP, IFX-20C

en

Power Wheelchair Base

User Manual



This manual **MUST** be given to the user of the product.
BEFORE using this product, this manual **MUST** be read and saved for future reference.



Yes, you can.

© 2020 Invacare Corporation

All rights reserved. Republication, duplication or modification in whole or in part is prohibited without prior written permission from Invacare. Trademarks are identified by ™ and ®. All trademarks are owned by or licensed to Invacare Corporation or its subsidiaries unless otherwise noted.

Invacare reserves the right to alter product specifications without further notice.

Making Life's Experiences Possible is a registered trademark in the U.S.A.

Contents

1 General	5
1.1 Introduction	5
1.2 Symbols in This Manual	5
1.3 Type of Use	6
1.3.1 Prescription Statement	6
1.4 Intended Use	6
1.5 Indication for Use	6
1.6 Service Life	6
2 Safety	7
2.1 General Guidelines	7
2.1.1 USB Charger	10
2.2 Pinch Points	11
2.3 Footplates and Front Rigging	11
2.4 Storage	12
2.5 Travel Information	12
3 Electromagnetic Compatibility (EMC) Information	15
3.1 Electromagnetic Interference (EMI) From Radio Frequency Sources	15
3.2 Powered Wheelchair Electromagnetic Interference (EMI)	16
3.3 Powered Wheelchair Electromagnetic Emissions	17
3.4 EMI Tables	18
4 Components	22
4.1 Component Overview	22
4.2 Remotes	23
4.3 The Powered Seating System	23
4.4 Labels on the Product	24
4.4.1 Symbols on the Labels	31
5 Setup	33
5.1 Setup/Delivery Inspection Information	33
6 Usage	34
6.1 Safety and Handling	34
6.1.1 A Note to Wheelchair Attendants	36
6.1.2 Stairways and Escalators	37
6.2 Stability and Balance	38
6.2.1 Driving Surfaces	39
6.2.2 Safety Information When Approaching Obstacles	39
6.2.3 The Correct Way to Approach Obstacles	40
6.2.4 Negotiating Inclines	41
6.2.5 Reaching, Leaning and Bending - Forward	42
6.2.6 Reaching, Leaning and Bending - Backward	43
6.2.7 Transferring To and From Other Seats	43
6.3 Weight Training and Other Activities	44
6.4 Pushing the Mobility Device in Freewheel Mode	45
6.4.1 Disengaging/Engaging the Motor Locks	45
7 Controls System	47
7.1 Electrical	47
7.2 Controls Protection System	47
7.3 Using the Battery Isolation Switch	48
7.4 Batteries	49
7.4.1 General Information on Charging	49
7.4.2 General Instructions on Charging	49
7.4.3 How to Charge the Batteries	50
7.4.4 How to Disconnect the Mobility Device After Charging ..	52
7.4.5 Storage and Maintenance	52
7.4.6 Using the Proper Batteries	52
7.4.7 Instructions on Using the Batteries	53
7.4.8 Transporting Batteries	55
7.4.9 General Instructions on Handling the Batteries	55

8 Transport - ISO 7176-19	56	Removing the Rear Shroud Assembly	75
8.1 Wheelchair Transport Brackets (TRBKTS)	56	Installing the Rear Shroud Assembly	76
8.2 Transport Ready Option (TRRO)	56	10.4.2 Removing/Installing the Front Shroud Assembly	77
8.3 Transport—General information	57	10.5 Battery Service	78
8.4 Transferring Mobility Device to Vehicle	58	10.5.1 General Instructions on Handling the Batteries	78
8.5 Use of the Mobility Device as a Seat in a Vehicle	59	10.5.2 How to Handle Damaged Batteries Correctly	78
8.5.1 How the Mobility Device is Anchored in a Vehicle	60	10.5.3 General Information on Battery Installation	79
8.5.2 How The User is Secured Within the Mobility Device	61	10.5.4 Removing the Batteries from the Wheelchair	80
8.6 Transporting the Mobility Device Without Occupant	63	10.5.5 Installing Batteries into the Wheelchair	82
9 Maintenance	64	10.5.6 Replacing Battery Cables	84
9.1 Wear and Tear Information	64	10.5.7 Cleaning Battery Terminals	86
9.2 User/Attendant Inspection Checklists	64	10.5.8 Recycling Batteries	87
9.2.1 Inspect/Adjust Weekly	65	11 After Use	88
9.2.2 Inspect/Adjust Monthly	65	11.1 Reuse	88
9.2.3 Inspect/Adjust Periodically	65	11.2 Disposal	88
9.3 Service Inspection Information	66	12 Troubleshooting	89
9.4 Cleaning	66	12.1 Driving Performance	89
9.5 Wheels and Tires	67	12.2 Control System	89
9.5.1 Damaged Wheels	67	12.2.1 Battery and Charger Tips	91
9.5.2 Pneumatic Tires	67	13 Technical Data	92
10 Service	69	13.1 Technical Specifications	92
10.1 Safety Information	69	13.2 ISO 7176-15 Annex A	97
10.1.1 Set Up	69	13.2.1 AVIVA FX with LiNX and Captain's Seat	97
10.1.2 Repair and Service Information — Providers and/or Qualified Technicians	71	13.2.2 AVIVA FX with LiNX and Ultra Low Maxx Seat	100
10.2 Setup/Delivery Inspection	72	14 Warranty	103
10.3 Service Inspection	73	14.1 Limited Warranty—US	103
10.3.1 Six Month Inspection	73	14.2 Limited Warranty—Canada	103
10.3.2 Replace Every 18 Months	75	14.3 Repair or Replacement	103
10.4 Removing/Installing the Shrouds	75	14.4 Limitations and Exclusions	104
10.4.1 Removing/Installing the Rear Shroud Assembly	75	14.5 Disclaimers	104

1 General

1.1 Introduction

Thank you for choosing an Invacare product.

This user manual contains important information about the handling of the product. In order to ensure safety when using the product, read the user manual carefully and follow the safety instructions.

Before reading this manual, make sure you have the latest version. You can find the latest version as a pdf on the Invacare website (see back page of this manual). If you find that the font size in the print version of the user manual is difficult to read, you can download the pdf from the website. The pdf can then be scaled on screen to a font size that is more comfortable for you.

The decision whether the model is suitable for the user may only be taken by medical specialists with appropriate expertise. Some maintenance and settings can be performed by the user or his/her attendants. Certain adjustments do however require technical training and may only be carried out by your Invacare qualified service technician. Refer to the Inspection checklists in *Chapter 9 Maintenance, page 64*. Damages and errors caused by nonobservance of the user manual or as a result of incorrect maintenance are excluded from all warranties.

For more information about the product, contact your local Invacare representative. For address and website see the end of this manual.

1.2 Symbols in This Manual

Signal symbols and/or words are used in this manual and apply to hazards or unsafe practices which could result in personal injury or property damage. See the information below for definitions of the signal words.



DANGER!

-Danger indicates a imminently hazardous situation which, if not avoided, could result in death or serious injury.



WARNING!

-Warning indicates a potentially hazardous situation which, if not avoided, could result in death or serious injury.



CAUTION!

-Caution indicates a potentially hazardous situation which, if not avoided, may result in property damage or minor injury or both.



IMPORTANT

-Indicates a hazardous situation that could result in damage to property if it is not avoided.



Gives useful tips, recommendations and information for efficient, trouble-free use.



Identifies required tools, components and items which are needed to carry out certain work.

	Battery Recycling Symbol — Lead Acid
	Recycle this product. Refer to Disposal and Recycling sections.
	Manufacturer

1.3 Type of Use

1.3.1 Prescription Statement

Per 21 CFR 801.109(b)(1) the device is labeled for prescription use.



CAUTION!

Federal Law (USA) restricts this device to sale by or on the order of a licensed physician.

1.4 Intended Use

The intended use of the device is to provide mobility and positioning to persons limited to a sitting position.

1.5 Indication for Use

The Invacare® AVIVA FX Power Wheelchair is indicated to provide mobility and positioning to persons limited to a sitting

position.

1.6 Service Life

The expected service life is five years, presuming that the product is used daily and in accordance with safety instructions, maintenance instructions and intended use, stated in this manual.

2 Safety

2.1 General Guidelines

The safety section contains important information for the safe operation and use of this product.

**WARNING!****Risk of Death, Injury or Damage**

Improper use of this product may cause injury or damage.

- If you are unable to understand the warnings, cautions or instructions, contact a health care professional or Provider before attempting to use this equipment.
- DO NOT use this product or any available optional equipment without first completely reading and understanding these instructions and any additional instructional material such as user manual, service manuals or instruction sheets supplied with this product or optional equipment.

**WARNING!****Risk of Death, Injury or Damage**

Continued use of the product with damaged parts could lead to the product malfunctioning, causing injury to the user and/or caregiver.

- Check all product components and carton for damage and test components before use. In case of damage or if the product is not working properly, stop using the product and contact a qualified technician or Invacare for repair.

**WARNING!****Risk of Serious Injury or Damage**

Use of unapproved accessories may result in serious injury or damage.

- Invacare products are specifically designed and manufactured for use in conjunction with approved Invacare accessories. Unapproved accessories have not been tested by Invacare for use with Invacare products.
- DO NOT use unapproved accessories.
- To obtain approved Invacare accessories, contact Invacare by phone or at www.invacare.com.



DANGER!

Risk of Death, Serious Injury, or Damage

Use of incorrect or improper replacement (service) parts may cause death, serious injury, or damage.

- Replacement parts **MUST** match original Invacare parts.
- ALWAYS** provide the wheelchair serial number to assist in ordering the correct replacement parts.



WARNING!

Risk of Serious Injury or Damage

Hardware that is loosely secured could cause loss of stability resulting in serious injury or damage.

- After **ANY** adjustments, repair or service and before use, make sure that all attaching hardware is tightened securely.



WARNING!

Risk of Serious Injury or Damage

Loss of power due to loose electrical connections could cause the wheelchair to suddenly stop resulting in serious injury or damage.

- ALWAYS** ensure that all electrical connections are tightly connected so they don't vibrate loose.



DANGER!

Risk of Death, Serious Injury, or Damage

Lighted cigarettes dropped onto an upholstered seating system can cause a fire resulting in death, serious injury, or damage.

Wheelchair occupants are at particular risk of death or serious injury from these fires and resulting fumes because they may not have the ability to move away from the wheelchair.

- DO NOT** smoke while using this wheelchair.



WARNING!

Risk of Injury, Damage or Death

Improper monitoring or maintenance may cause injury, damage or death due to ingestion or choking on parts or materials.

- Closely supervise children, pets, or people with physical/mental disabilities.



WARNING!

Risk of Injury

Operating the wheelchair with depleted batteries may lead to stranding of the wheelchair user.

- ALWAYS** check the battery charge level before using the wheelchair.
- Before using the power wheelchair, charge the batteries following the guidelines in this user manual.
- DO NOT** use the wheelchair with depleted batteries.

**WARNING!****Risk of Injury or Damage**

Improper mounting or maintenance of the Sip-n-Puff control including the mouthpiece and breath tube may cause injury or damage.

Water inside the Sip-n-Puff interface module may cause damage to the unit.

Excessive saliva residue in the mouthpiece/straw can reduce performance.

Blockages, a clogged saliva trap or air leaks in the system may cause Sip-n-Puff not to function properly.

- Ensure moving parts of the wheelchair, including the operation of powered seating, DO NOT pinch or damage the Sip-n-Puff tubing.

- Saliva trap MUST be installed to reduce risk of water or saliva entering the Sip-n-Puff interface module.

- Occasionally flush the mouthpiece to remove saliva residue.

- The mouthpiece/straw MUST be completely dry before installation.

- If Sip-n-Puff does not function properly, inspect system for blockages, clogged saliva trap or air leaks.

As necessary, replace mouthpiece, breath tube and saliva trap.



Contact your Invacare provider for more information about maintaining and troubleshooting the Sip-n-Puff system.

**WARNING!****Risk of Injury, Damage or Death**

Exposure to liquids may cause injury, damage or death.

- DO NOT expose electrical connections to sources of liquid or dampness. This includes, but is not limited to, water, body fluids or cleaning agents.

- DO NOT expose battery charger or other accessories to sources of liquid or dampness.

- Wheelchairs that are used by incontinent users and/or are frequently exposed to water/liquids may require replacement and inspection of electrical components more frequently than normal schedule dictates.

- Electrical components damaged by corrosion MUST be replaced immediately.



CAUTION!

Risk of Damage

Operating the wheelchair in rain or dampness may cause the wheelchair to malfunction electrically and mechanically, may cause the wheelchair to prematurely rust or may damage the upholstery.

- DO NOT leave wheelchair in a rain storm of any kind.
- DO NOT use wheelchair in a shower.
- DO NOT leave wheelchair in a damp area for any length of time.
- Check to ensure that the battery covers are secured in place, joystick boot is NOT torn or cracked where water can enter and that all electrical connections are secure at all times. DO NOT use if the joystick boot is torn or cracked. If the joystick boot becomes torn or cracked, replace IMMEDIATELY.



WARNING!

Risk of Injury or Damage

Use of the power wheelchair outside of specified operating conditions may cause unintended or erratic movement. This may include, but is not limited to impacts and sudden stops. To avoid injury or damage:

- Only use the power wheelchair in the operating conditions specified in the Technical Data chapter of this manual.



THE INFORMATION CONTAINED IN THIS DOCUMENT IS SUBJECT TO CHANGE WITHOUT NOTICE.



As a manufacturer of wheelchairs, Invacare endeavors to supply a wide variety of wheelchairs to meet many needs of the end user. However, final selection of the type of wheelchair to be used by an individual rests solely with the user and his/her healthcare professional capable of making such a selection. Invacare recommends working with a qualified rehab technology provider, such as an ATP, (Assistive Technology Professional).

2.1.1 USB Charger



WARNING!

Risk of Injury

If you use mobile phone while operating mobility device, accidents could lead to injury or property damage.

- Only use mobile phone in conjunction with hands-free equipment to operate mobility device while driving.



Risk of property damage

Handle USB charger with care, otherwise damage could occur.

- Always keep the USB charger dry. If USB charger gets wet, let USB charger dry before use.
- Do not use or store USB charger in dusty or dirty areas.
- Do not insert sharp objects into the USB ports.

**WARNING!****Risk of Injury or Damage**

Erratic or unintended movement of the wheelchair may occur if wireless transmitters are connected to the wheelchair. To avoid injury or damage:

- DO NOT use the USB charger connector as a wireless transmitter.
- The USB Port is NOT intended for communication purposes or to upload information to the device.
- Only use the USB charger for the purposes described in the remote manual.

2.2 Pinch Points**WARNING!****Risk of Minor to Serious Injury**

Pinch points can cause minor to serious injury.

- Be mindful of potential pinch points and use caution when using this product.

**WARNING!****Risk of Injury**

Pinch points can cause injury.

- Be aware that a pinch point (A) exists between the head tube cap and rear swingarm.
- Be aware that a pinch point (C) may occur when rotating the center mount front rigging assembly.

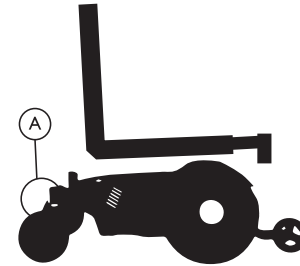

Fig. 2-1 Pinch Points — Head Tube Cap/Walking Beam and Telescoping Tube

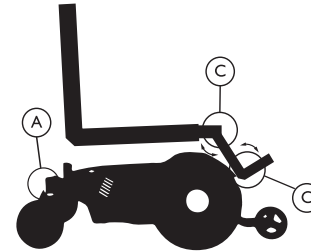

Fig. 2-2 Pinch Points — Center Mount Front Rigging

2.3 Footplates and Front Rigging**WARNING!****Risk of Serious Injury or Damage**

Operating the wheelchair with a clearance of less than 75 mm (3 inches) between the footplates and the ground/floor may cause serious injury or property damage.

- ALWAYS maintain a minimum of 75 mm (3 inches)



between the bottom of the footplates and ground/floor to ensure proper clearance while the wheelchair is in motion. If necessary, adjust the footplates height to achieve proper clearance. After footplates height adjustment, if the wheelchair dips forward and the footplates touch the ground while in motion, please contact your provider for an inspection and avoid use of the wheelchair if possible.

2.4 Storage



WARNING!

Risk of Injury, Damage or Death

Storage or use near heat sources and combustible products may result in injury or damage.

- DO NOT store or use wheelchair near open flames or other heat sources.
- DO NOT store or use wheelchair near combustible products.

2.5 Travel Information

This section contains information useful when making travel arrangements for your power wheelchair.

Before Traveling

Contact your travel carrier and/or tour guide about your travel plans and provide information about your intent to travel with your power wheelchair. The carrier will let you know of any additional requirements.

Battery Information

Batteries	<ul style="list-style-type: none"> • Number: 2 • Type: GP24 • Chemistry: Sealed VRLA Gel • Operating Voltage: 24V nominal (2 x 12 V) • GP24 Battery weight: approximately 51.5 lbs (23.4 kg) per battery • GP24 Amp-Hour Rating: 73.6 Ah (C20) (63 Ah (C5)) • Circuit breaker: 63 Amps, 5 KA rated break capacity
-----------	--

Dimension Information

Overall height (with elevate and headrest)	<ul style="list-style-type: none"> • 43 in (1100 mm)
Maximum base width	<ul style="list-style-type: none"> • 24.25 in (616 mm)

Maximum length (including center-mounted front rigging)	<ul style="list-style-type: none"> 51.4 in (1305 mm) at 0°
--	---

Weight Information

Total mass	379.2–434.3 lb (172–197 kg)
------------	-----------------------------

Lifting Information

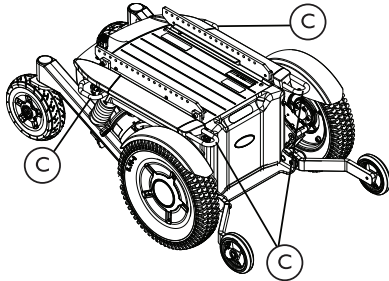

Use the transport brackets © for lifting/handhold locations.

Drive Disconnect Information

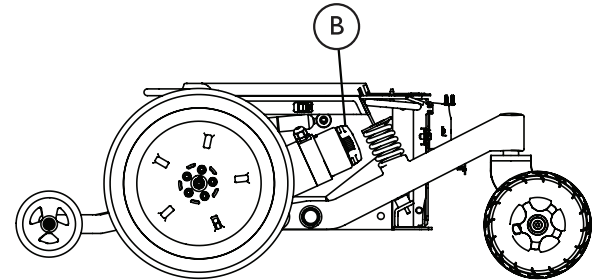
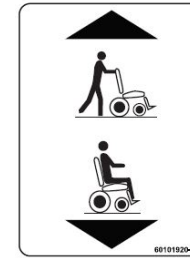

To push the power wheelchair, ensure it is off, then rotate the motor locks ② to engage/disengage the motor:

- Disengage (PUSH) - Rotate the motor locks UP to disengage the motors and push the wheelchair.
- Engage (DRIVE) - Rotate the motor locks DOWN to engage the motors and drive the wheelchair.

Power Disconnect Information

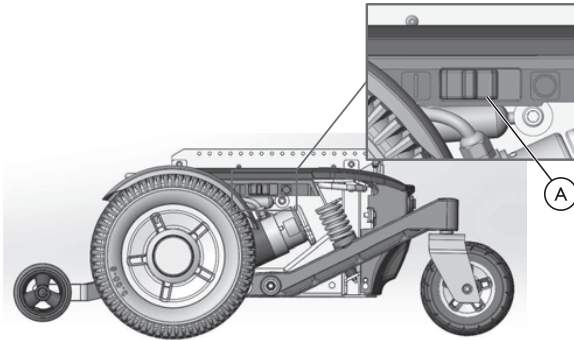

U. S. Department of Transportation — 49 CFR Parts 171, 172, 173, 175

General information regarding Passengers with Disabilities may be found at

<https://www.transportation.gov/airconsumer/passengers-disabilities>

Use the battery isolation switch Ⓐ to disconnect the power.

- Disconnect — Slide the switch towards the BACK of the wheelchair. The power will turn off.
- Connect — Slide the switch towards the FRONT of the wheelchair. The power will turn on.

Damage Prevention

Secure or remove fragile components prior to transporting the wheelchair. The wheelchair controls can often be folded in towards the center of the chair. Wrap sensitive components (electronics, etc.) in soft, shock-absorbing material (foam, bubble wrap, towel, etc.). Ensure cables are secured.

Reference Information

U.S. Air Carrier Access Act — 49 USC § 41705

14 CFR Part 382

3 Electromagnetic Compatibility (EMC) Information

3.1 Electromagnetic Interference (EMI) From Radio Frequency Sources

Powered wheelchairs and motorized scooters (in this text, both will be referred to as mobility devices) may be susceptible to electromagnetic interference (EMI), which is interfering electromagnetic energy (EM) emitted from sources such as radio stations, TV stations, amateur radio (HAM) transmitters, two way radios, and cellular phones. The interference (from radio wave sources) can cause the mobility devices to release its brakes, move by itself, or move in unintended directions. It can also permanently damage the mobility devices control system. The intensity of the interfering EM energy can be measured in volts per meter (V/m). Each powered mobility device can resist EMI up to a certain intensity. This is called its "immunity level." The higher the immunity level, the greater the protection. At this time, current technology is capable of achieving at least a 20 V/m immunity level, which would provide useful protection from the more common sources of radiated EMI.

There are a number of sources of relatively intense electromagnetic fields in the everyday environment. Some of these sources are obvious and easy to avoid. Others are not apparent and exposure is unavoidable. However, we believe that by following the warnings listed below, your risk to EMI will be minimized.

The sources of radiated EMI can be broadly classified into three types:

1. Hand-held Portable transceivers (transmitters/receivers with the antenna mounted directly on the transmitting unit. Examples include: citizens band (CB) radios, "walkie talkie", security, fire and police transceivers, cellular telephones, and other personal communication devices).
 -  Some cellular telephones and similar devices transmit signals while they are ON, even when not being used.
2. Medium-range mobile transceivers, such as those used in police cars, fire trucks, ambulances and taxis. These usually have the antenna mounted on the outside of the vehicle.
3. Long-range transmitters and transceivers, such as commercial broadcast transmitters (radio and TV broadcast antenna towers) and amateur (HAM) radios.



Other types of handheld devices, such as cordless phones, laptop computers, AM/FM radios, TV sets, CD players, cassette players, and small appliances, such as electric shavers and hair dryers, so far as we know, are not likely to cause EMI problems to your powered mobility device.

3.2 Powered Wheelchair Electromagnetic Interference (EMI)

Because EM energy rapidly becomes more intense as one moves closer to the transmitting antenna (source), the EM fields from handheld radio wave sources (transceivers) are of special concern. It is possible to unintentionally bring high levels of EM energy very close to the mobility devices control system while using these devices. This can affect the mobility device's movement and braking. Therefore, the warnings listed below are recommended to prevent possible interference with the control system of the mobility device.

Electromagnetic interference (EMI) from sources such as radio and TV stations, amateur radio (HAM) transmitters, two-way radios, and cellular phones can affect powered wheelchairs and motorized scooters.

FOLLOWING THE WARNINGS LISTED BELOW SHOULD REDUCE THE CHANCE OF UNINTENDED BRAKE RELEASE OR POWERED WHEELCHAIR MOVEMENT WHICH COULD RESULT IN SERIOUS INJURY.



WARNING!

- DO NOT operate handheld transceivers (transmitters receivers), such as citizens band (CB) radios, or turn ON personal communication devices, such as cellular phones, while the mobility device is turned ON;
- Be aware of nearby transmitters, such as radio or TV stations, and try to avoid coming close to them;
- If unintended movement or brake release occurs, turn the mobility device OFF as soon as it is safe;
- Be aware that adding accessories or components, or modifying the mobility device, may make it more susceptible to EMI (Note: There is no easy way to evaluate their effect on the overall immunity of the mobility device); and
- Report all incidents of unintended movement or brake release to Invacare and note whether there is a source of EMI nearby.

**WARNING!****Important Information**

- 20 volts per meter (V/m) is a generally achievable and useful immunity level against EMI (as of May 1994) (the higher the level, the greater the protection);
- This device has been tested to a radiated immunity level of 20 volts per meter.
- The immunity level of the product is unknown.
- Modification of any kind to the electronics of this mobility device as manufactured by Invacare may adversely affect the EMI immunity levels.

3.3 Powered Wheelchair Electromagnetic Emissions

**CAUTION!****Risk of Injury or Damage**

EMC interference affecting other products may result in injury or damage.

To avoid impacting the operation and function of other products:

- Products not specified by Invacare that may be used on or near the mobility device may be impacted by emissions from this product if they have a sensitivity level that is lower than the recognized standard and provided by this mobility device. Refer to the manufacturer specifications for any electronic device **BEFORE** use near this product to determine its level of immunity and potential risk.

3.4 EMI Tables

Guidance and manufacturer's declaration – electromagnetic immunity			
The AVIVA FX Power Wheelchair is intended for use in the electromagnetic environment specified below. The customer or the user of the AVIVA FX Power Wheelchair should assure that it is used in such an environment.			
IMMUNITY test	IEC 60601 test level	Compliance level	Electromagnetic environment – guidance
Electrostatic discharge (ESD) IEC 61000-4-2	± 6 kV contact ± 8 kV air	ISO 7176-21: +/- 6 kV contact, +/- 8 kV air	Floors should be wood, concrete or ceramic tile. If floors are covered with synthetic material, the relative humidity should be at least 30 %.
Electrical fast transient/burst IEC 61000-4-4	± 2 kV for power supply lines ± 1 kV for input/output	+/-1 kV	Mains power quality should be that of a typical commercial or hospital environment.
Surge IEC 61000-4-5	± 1 kV line(s) to line(s) ± 2 kV line(s) to earth	+/-1 kV line to line	Mains power quality should be that of a typical commercial or hospital environment.
Voltage dips, short interruptions and voltage variations on power supply input lines IEC 61000-4-11	<5 % U_T (>95 % dip in U_T) for 0,5 cycle 40 % U_T (60 % dip in U_T) for 5 cycles 70 % U_T (30 % dip in U_T) for 25 cycles <5 % U_T (>95 % dip in U_T) for 5 s	40 % U_T (60 % dip in U_T) for 5 cycles 70 % U_T (30 % dip in U_T) for 25 cycles <5 % U_T (>95 % dip in U_T) for 5 s	Mains power quality should be that of a typical commercial or hospital environment. If the user of the AVIVA FX Power Wheelchair Battery Charger requires continued operation during power mains interruptions, it is recommended that the AVIVA FX Power Wheelchair Battery Charger be powered from an uninterruptible power supply or battery.

Power frequency (50/60 Hz) magnetic field IEC 61000-4-8	3 A/m	30 A/m	Power frequency magnetic fields should be at levels characteristic of a typical location in a typical commercial or hospital environment.
---	-------	--------	---

NOTE: U_T is the a.c. mains voltage prior to application of the test level.

Guidance and manufacturer's declaration – electromagnetic immunity

The AVIVA FX Power Wheelchair is intended for use in the electromagnetic environment specified below. The customer or the user of the AVIVA FX Power Wheelchair should assure that it is used in such an environment.

IMMUNITY test	IEC 60601 TEST LEVEL	Compliance level	Electromagnetic environment – guidance
Conducted RF IEC 61000-4-6	3 Vrms 150 kHz to 80 MHz	3 Vrms	<p>Portable and mobile RF communications equipment should be used no closer to any part of the AVIVA FX Power Wheelchair, including cables, than the recommended separation distance calculated from the equation applicable to the frequency of the transmitter.</p> <p>Recommended separation distance</p> $d = \left[\frac{3,5}{V_1} \right] \sqrt{P} \quad (3.5/3 \text{ V/m} = 1.667)$ $d = \left[\frac{3,5}{E_1} \right] \sqrt{P} \quad 26 \text{ MHz to } 800 \text{ MHz } (3.5/20 \text{ V/m} = 0.175)$ $d = \left[\frac{7}{E_1} \right] \sqrt{P} \quad 800 \text{ MHz to } 2,5 \text{ GHz } (7/20 \text{ V/m} = 0.35)$
Radiated RF IEC 61000-4-3	3 V/m 80 MHz to 2,5 GHz	20 V/m 26 MHz to 2.5 GHz per ISO 7176-21	

			<p>where P is the maximum output power rating of the transmitter in watts (W) according to the transmitter manufacturer and d is the recommended separation distance in metres (m). Field strengths from fixed RF transmitters, as determined by an electromagnetic site survey,^a should be less than the compliance level in each frequency range.^b Interference may occur in the vicinity of equipment marked with the following symbol:</p> 
--	--	--	--

NOTE 1 At 80 MHz and 800 MHz, the higher frequency range applies.

NOTE 2 These guidelines may not apply in all situations. Electromagnetic propagation is affected by absorption and reflection from structures, objects and people.

^a Field strengths from fixed transmitters, such as base stations for radio (cellular/cordless) telephones and landmobile radios, amateur radio, AM and FM radio broadcast and TV broadcast cannot be predicted theoretically with accuracy. To assess the electromagnetic environment due to fixed RF transmitters, an electromagnetic site survey should be considered. If the measured field strength in the location in which the AVIVA FX Power Wheelchair is used exceeds the applicable RF compliance level above, the AVIVA FX Power Wheelchair should be observed to verify normal operation. If abnormal performance is observed, additional measures may be necessary, such as re-orienting or relocating the AVIVA FX Power Wheelchair.

^b Over the frequency range 150 kHz to 80 MHz, field strengths should be less than $[V_1]$ V/m.

Recommended separation distances between portable and mobile RF communications equipment and the AVIVA FX Power Wheelchair

The AVIVA FX Power Wheelchair is intended for use in an electromagnetic environment in which radiated RF disturbances are controlled. The

customer or the user of the AVIVA FX Power Wheelchair can help prevent electromagnetic interference by maintaining a minimum distance between portable and mobile RF communications equipment (transmitters) and the AVIVA FX Power Wheelchair as recommended below, according to the maximum output power of the communications equipment.

Rated maximum output power of transmitter W	Separation distance according to frequency of transmitter m		
	150 kHz to 80 MHz $d = \left[\frac{3,5}{V_1}\right]\sqrt{P}$	26 MHz to 800 MHz $d = \left[\frac{3,5}{E_1}\right]\sqrt{P}$	800 MHz to 2,5 GHz $d = \left[\frac{7}{E_1}\right]\sqrt{P}$
0,01	0.167 m	0.0175 m	0.035 m
0,1	0.53 m	0.055 m	0.11 m
1	1.67 m	0.175 m	0.35 m
10	5.3 m	0.55 m	1.1 m
100	16.7 m	1.75 m	3.5 m

For transmitters rated at a maximum output power not listed above, the recommended separation distance d in metres (m) can be estimated using the equation applicable to the frequency of the transmitter, where P is the maximum output power rating of the transmitter in watts (W) according to the transmitter manufacturer.

NOTE 1 At 80 MHz and 800 MHz, the separation distance for the higher frequency range applies.

NOTE 2 These guidelines may not apply in all situations. Electromagnetic propagation is affected by absorption and reflection from structures, objects and people.

4 Components

4.1 Component Overview



Fig. 4-1 AVIVA FX with Ultra Low Maxx Seating



Fig. 4-2 AVIVA FX with Captain's Seat

ITEM	DESCRIPTION
A	Back Cushion
B	Armrest
C	Remote (Joystick)
D	Seat Cushion
E	Drive Wheel
F	Fork
G	Caster
H	Front Rigging
I	Back Cane
J	Headrest
K	Anti-tipper

4.2 Remotes

Remotes include joysticks and other devices used to drive the power wheelchair, operate the powered seating system or operate other functions. Your power wheelchair may be equipped with one of several different remotes. For information on the different functions and how to operate a particular remote, refer to its corresponding user manual (enclosed).

4.3 The Powered Seating System

The powered seating system is operated from the remote. Refer to the remote manual for more information. The powered seating system may include the following functions, depending on the modules installed:

- Tilt
- Recline
- Tilt with Elevating Seat
- Tilt and Recline with Elevating Seat
- Power Elevating Center Mount Legrest
- Power Elevating Dual Legrests



Information regarding operation of the elevating seat at temperatures of less than 0 °C

- Invacare mobility devices are equipped with safety mechanisms that prevent capacity overload of the electronic components. At operating temperatures below freezing point this can, in particular, lead to the elevating seat actuator being shut down after approximately 1 second operating time.
- The elevating seat can be raised or lowered gradually by repeatedly operating the joystick. In many cases this generates sufficient heat for the actuator to operate as normal.



Drive Slow-Down

The drive slow-down reacts in different ways, depending on the mobility device's configuration.

- The elevating seat is equipped with sensors which reduce the mobility device's speed as soon as the elevating seat is raised above a certain point. The wheelchair is also equipped with a sensor that reduces speed when the seat is tilted or reclined past a specific angle.
- The drive slow-down takes place to guarantee the tipping stability of the mobility device and to avoid personal risk and damage to the mobility device.
- To reapply normal speed, lower the elevating seat down or return the seat back to an upright position until the drive slow-down switches off.



CAUTION!

Risk of Injury or Damage

There is a risk of tipping if the drive slow-down sensors fail when the elevating seat is raised.
-If you find that the drive slow-down function is not working when the elevating seat is raised, do not drive with the elevating seat raised and immediately contact an Invacare provider.

4.4 Labels on the Product



DANGER!

Risk of Injury, Damage or Death

Missing or damaged labels may contribute to injury, damage or death.

-Ensure ALL labels are present and legible.



Labels are subject to change without notice.

All Wheelchairs

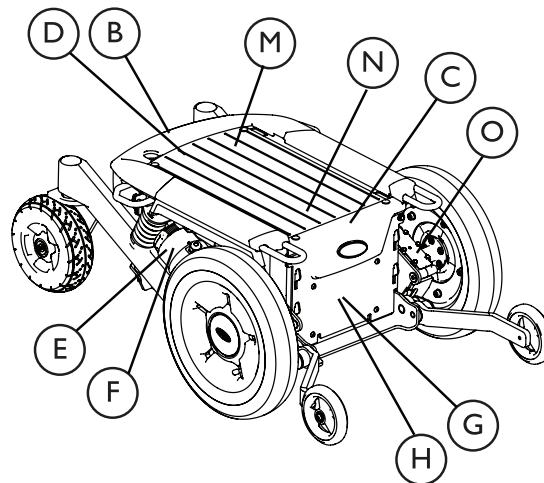

Fig. 4-3 Label Location

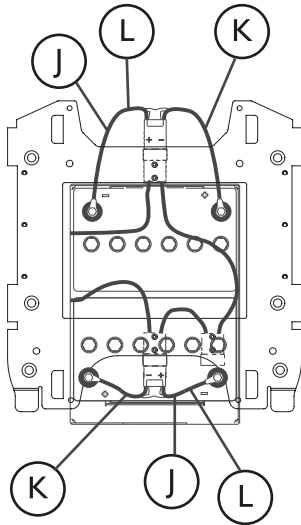

Fig. 4-4 Battery Wiring Label Location

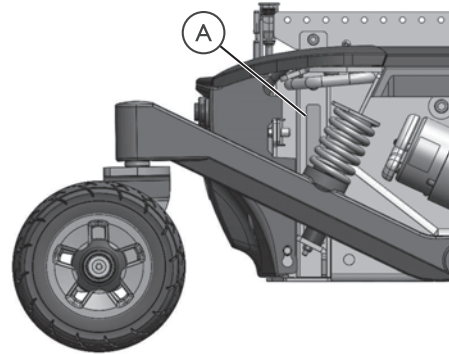

Fig. 4-5 Serial Number Label Location

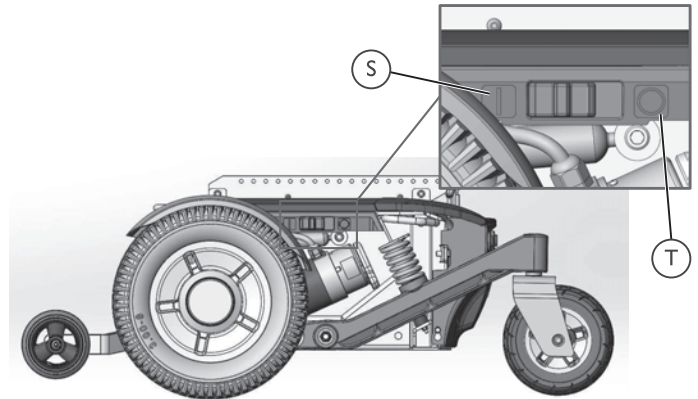



Fig. 4-6 Battery Interruption Switch Labels

S	60108775	 <p data-bbox="459 273 738 297"><i>Fig. 4-14 Power On Label</i></p>
T	60108776	 <p data-bbox="459 508 738 533"><i>Fig. 4-15 Power Off Label</i></p>

G	60101922
---	----------

⚠ WARNING

Wiring Diagram Install/Remove for GP24 Batteries
DO NOT REMOVE THIS LABEL

Risk of Death or Serious Injury
Failure to observe these warnings can cause an electrical short resulting in death, serious injury, or damage to the electrical system.



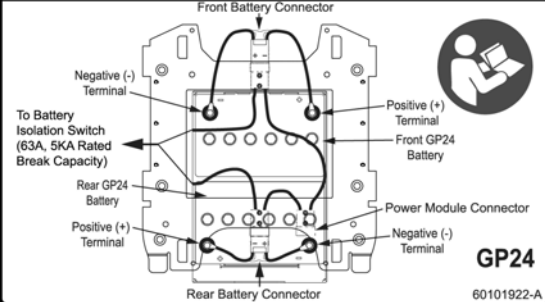

- The **POSITIVE (+)** Battery Cable **MUST** connect to the **POSITIVE (+)** Battery Terminal.
- The **NEGATIVE (-)** Battery Cable **MUST** connect to the **NEGATIVE (-)** Battery Terminal.
- **NEVER** allow any of your tools and/or battery cables to contact **BOTH** battery posts at the same time.
- Install protective caps on positive and negative battery terminals.
- Replace cables immediately if cable insulation becomes damaged.

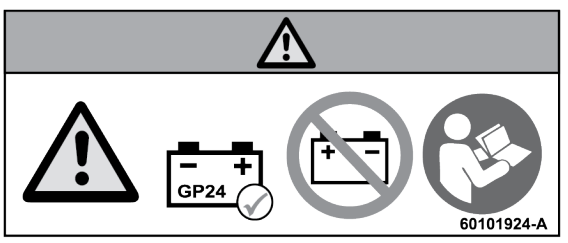

GP24
60101922-A

*Fig. 4-16 **GP24 Battery Wiring Diagram Label*

H	60101924
 <p>The label features a warning triangle at the top center. Below it, on the left, is another warning triangle. In the center is a GP24 battery with a checkmark, indicating the correct terminal configuration (negative on the left, positive on the right). To the right of the battery is a crossed-out battery icon, indicating that reverse terminal configuration is prohibited. On the far right is an icon of a person reading a manual. The label is identified as 60101924-A.</p>	
<p><i>Fig. 4-17 **GP24 Battery Terminal Configuration Label</i></p> <p>WARNING —GP24 batteries with terminal configuration (negative on the left and positive on the right) as shown MUST be used. GP24 batteries that have the reverse terminal configuration MUST NOT be used. These recommendations MUST be followed, otherwise injury and/or damage may occur.</p>	

J	60101928	 <p>The label shows two GP24 batteries with their terminals. It includes a warning triangle and a crossed-out battery icon.</p>
		<p><i>Fig. 4-18 GP24 Battery Label</i></p> <p>Use GP24 batteries Only. See User Manual.</p>
K	60101918	 <p>The label shows two positive battery terminals with a plus sign (+) and the text 'POSITIVE'.</p>
		<p><i>Fig. 4-19 Positive Battery Cable Label</i></p>
L	60101919	 <p>The label shows two negative battery terminals with a minus sign (-) and the text 'NEGATIVE'.</p>
		<p><i>Fig. 4-20 Negative Battery Cable Label</i></p>
M	60101926	 <p>The label contains contact information for Invacare in various regions: USA, Canada, Australia, and Germany. It also includes a small icon of a person reading a manual.</p>
		<p><i>Fig. 4-21 Contact/Consult Manual Label</i></p>

		<p>READ MANUAL — Before using this product, read and understand the User Manual. The user manual provides proper operation and safe practices. Documentation can be obtained at the addresses listed.</p>
N	1195057	<div style="border: 1px solid black; padding: 5px; text-align: center;"> <p>This product may be covered by one or more U.S. patents or pending patent applications. See www.invacarepatents.com</p> </div> <p><i>Fig. 4-22 Patent Label</i></p>
O	1195679	<div style="border: 1px solid black; padding: 5px; text-align: center;"> <p>WARNING <small>Risk of Injury, Damage or Death. Loss of traction or stability on rough or unstable terrain may cause injury, damage or death. Use care when operating the wheelchair on rough or unstable terrain. This would include but is not limited to areas of rock, mulch, mud, uneven pavement, roots and similar conditions. Be aware of your surroundings and conditions that might affect the ability to operate the wheelchair. 1195679</small></p> </div> <p><i>Fig. 4-23 Driving Surfaces Label</i></p>



- * Label located under the controller.
- ** Labels located under rear shroud.

Wheelchairs with the Transport Ready Option - ISO 7176-19

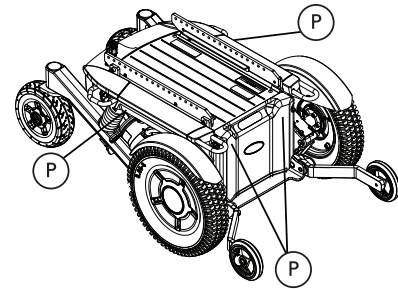

Fig. 4-24 Wheelchairs with the Transport Ready Option - ISO 7176-19

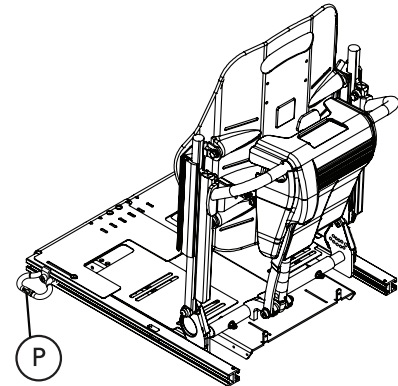

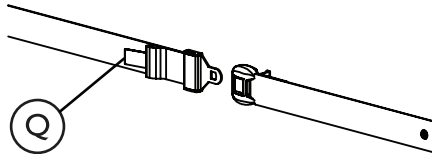



Fig. 4-25 Ultra Low Maxx Seats with Elevate and the Transport Ready Option - ISO 7176-19

ITEM	PART NUMBER	DESCRIPTION
P	1554407	 <p>ISO 7176-19</p> <p><i>Fig. 4-26 ISO 7176-19 Compliance Label</i></p>

On ALL Positioning Belts



ITEM	PART NUMBER	DESCRIPTION
Q	1195716	 <p>ISO 7176-19</p>

ITEM	PART NUMBER	DESCRIPTION
		<i>Fig. 4-27 ISO 7176-19 Non-Compliance Label</i>

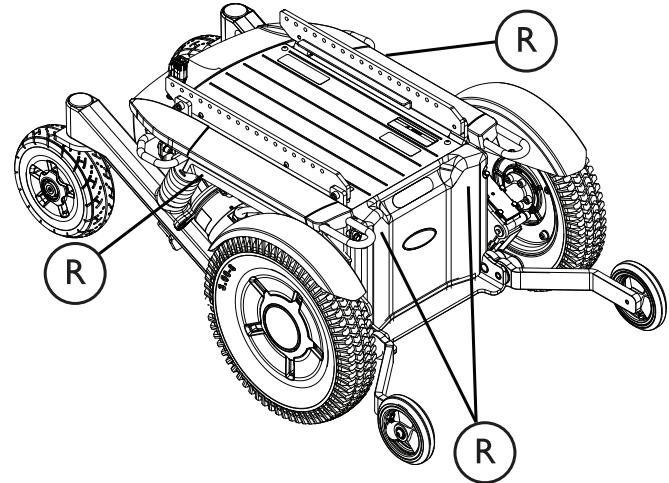

Wheelchairs with Transport Brackets (TRBKTS)











ITEM	PART NUMBER	DESCRIPTION
R	1553016	 <p data-bbox="416 362 719 423">Fig. 4-28 ISO 7176-19 Non-Compliance Label</p>





4.4.1 Symbols on the Labels

Refer to the following table for an explanation of the symbols on the labels.

Symbol	Description
	<p data-bbox="493 682 657 742">ISO 7000:2175 Seat Weight</p>
	<p data-bbox="400 813 746 906">Read Manual Symbol is on a BLUE mandatory action background.</p>

	<p data-bbox="1134 98 1485 266">Push position of motor lock. In this position the motor is disengaged and the wheels turn freely. The wheelchair can be pushed by an attendant.</p> <ul data-bbox="1150 295 1493 479" style="list-style-type: none"> <li data-bbox="1150 295 1406 356">• The remote must be switched off. <li data-bbox="1150 381 1493 479">• Refer to 6.4 <i>Pushing the Mobility Device in Freewheel Mode</i>, page 45.
	<p data-bbox="1134 512 1506 647">Drive position of the motor lock. In this position the motor is engaged. The remote will operate the mobility device.</p> <ul data-bbox="1150 676 1410 770" style="list-style-type: none"> <li data-bbox="1150 676 1410 770">• Both motors must be engaged to drive the wheelchair.
	<p data-bbox="1225 820 1414 881">IEC 60417 - 5007 Power On</p>

	<p>IEC 60417 - 5008 Power Off</p>
	<p>Battery Type and Terminal Polarity Symbol Use GP24 batteries with terminal polarity of Negative on the left and positive on the right. Checkmark is GREEN.</p>
	<p>DO NOT use this battery terminal polarity Prohibition symbol is RED.</p>
	
	<p>Required Battery Type and Terminal Polarity Symbol Use GP24 batteries with terminal polarity of Negative on the left and positive on the right.</p>

	<p>Symbol is on a BLUE mandatory action background.</p>
	<p>IEC 60417 - 5005 Positive Polarity Symbol is on a RED background.</p>
	<p>IEC 60417 - 5006 Negative Polarity Symbol is on a BLACK background.</p>
 <p>ISO 7176-19</p>	<p>ISO 7176 — 19 Compliance Refer to 8.2 <i>Transport Ready Option (TRRO)</i>, page 56.</p>
 <p>ISO 7176-19</p>	<p>ISO 7176 — 19 Non-Compliance Refer to 8.1 <i>Wheelchair Transport Brackets (TRBKTS)</i>, page 56.</p>

5 Setup

5.1 Setup/Delivery Inspection Information



Setup/delivery inspection should be performed by provider at time of delivery/set up.

PROVIDERS — Refer to *10.2 Setup/Delivery Inspection, page 72* for a setup/delivery inspection checklist.

Initial adjustments should be made to suit your personal body structure needs and preference.

Thereafter weekly, monthly and periodic inspections should be performed by user/attendant between the six month service inspections. Refer to *Chapter 9 Maintenance, page 64*.

6 Usage

6.1 Safety and Handling

Safety and handling of the wheelchair requires the close attention of the wheelchair user as well as the assistant. This manual points out the most common procedures and techniques involved in the safe operation and maintenance of the wheelchair. It is important to practice and master these safe techniques until you are comfortable in maneuvering the wheelchair.

Users and attendants must be aware that the handling and maneuverability characteristics of the wheelchair are inherently different based on the drive wheel location. Handling and maneuverability differences will be most noticeable when traveling down declines (Example: ramps and slopes) or over obstacles and rough terrain as this may shift the users center of mass forward resulting in decreased stability. ALWAYS reduce speed and wear the seat positioning strap when driving under these conditions.

Individual wheelchair users often develop skills to deal with daily living activities that may differ from those described in this manual. Invacare recognizes and encourages each individual to try what works best for him/her in overcoming obstacles that they may encounter. However all warnings and cautions given in this manual MUST be followed. Techniques in this manual are a starting point for the new wheelchair user and assistant with “safety” as the most important consideration for all. Invacare strongly recommends that initial use of wheelchairs be supervised by an assistant.

**DANGER!****Risk of Death, Serious Injury, or Damage**

Misuse of the wheelchair may cause component failure and/or the wheelchair to start smoking, sparking, or burning. Death, serious injury, or damage may occur due to fire.

-DO NOT use the wheelchair other than its intended purpose. If the wheelchair starts smoking, sparking, or burning, discontinue using the wheelchair and seek service IMMEDIATELY.

**DANGER!****Risk of Death or Serious Injury**

Not wearing your seat positioning strap could result in death or serious injury.

-ALWAYS wear your seat positioning strap. Your seat positioning strap helps reduce the possibility of a fall from the wheelchair. The seat positioning strap is a positioning belt only. It is not designed for use as a safety device withstanding high stress loads such as auto or aircraft safety belts. If signs of wear appear, seat positioning strap MUST be replaced IMMEDIATELY.

**WARNING!****Risk of Injury, Damage or Death**

Use of the wheelchair while judgement or ability is impaired may result in injury, damage or death.

- DO NOT operate the wheelchair under the influence of alcohol, medications or other substances that impair judgement or function.
- Changing medications may affect your ability to operate the wheelchair. Discuss the impact on your ability to operate the wheelchair with a health care professional when changing medications.
- DO NOT operate the wheelchair under conditions where judgement or function may be impaired. This may include but is not limited to lack of sleep or poor sight.
- Always be aware of your surroundings.

**WARNING!****Risk of Injury, Damage or Death**

Misuse of wheelchair may result in injury, damage or death.

- Use care when operating the wheelchair on roads, streets or other roadways.
- Use care when operating the wheelchair when vision is impaired by poor lighting such as unlit rooms, during the night or similar situations.
- ALWAYS be aware of motor vehicles and your surroundings.

**WARNING!****Risk of Injury, Damage or Death**

Conditions such as restlessness, mental deterioration, dementia, seizure disorders (uncontrolled body movement) or sleeping problems may cause injury, damage or death.

- Monitor patients with these conditions frequently.
- Close supervision and attention is needed when operating the wheelchair near children, pets or people with physical/mental disabilities.

**WARNING!****Risk of Injury or Damage**

To avoid injury or damage from moving parts:

- ALWAYS keep hands and fingers clear of moving parts.
- Closely supervise children, pets, or people with physical/mental disabilities.



WARNING!

Risk of Injury or Damage

Improper operation may change the normal balance, center of gravity or weight distribution of the wheelchair causing injury or damage.

- Determine and establish your particular safety limits. Practice bending, reaching and transferring activities in several combinations in the presence of a qualified healthcare professional before attempting active use of the wheelchair.
- ALWAYS shift your weight in the direction you are turning. Shifting your weight in the opposite direction of the turn may cause the inside drive wheel to lose traction.



WARNING!

Risk of Serious Injury

Impacting objects in the surrounding environment can cause serious injury.

- When maneuvering the wheelchair around, ALWAYS have assured cleared distance with all objects in environment.



WARNING!

- Always check grips for looseness before using the wheelchair. If loose, contact a qualified technician for instructions.



WARNING!

Risk of Injury or Damage

Unintended movement or operation of wheelchair may cause injury or damage.

- Turn power OFF BEFORE entering or exiting the wheelchair.
- Close supervision and attention is needed when operating the wheelchair near children pets or people with physical/mental disabilities. Turn power off.



WARNING!

Risk of Injury, Damage or Death

Damaged parts due to collision or impact may result in injury, damage or death.

- Seek immediate attention and service if wheelchair is involved in a collision or impact event. This includes, but is not limited to, vehicle accidents, mishandling and impact events where the wheelchair strikes something or is struck by something that may cause damage.
- Ensure your wheelchair is working properly and is inspected by a qualified Invacare technician if the wheelchair is involved in a collision or impact event.

6.1.1 A Note to Wheelchair Attendants

When assistance to the wheelchair user is required, remember to use good body mechanics. Keep your back straight and bend your knees whenever tilting wheelchair or traversing curbs or other impediments.

Ensure that only secure, non-detachable parts are used for hand-hold supports.

When learning a new assistance technique, have an experienced attendant help you before attempting it alone.

6.1.2 Stairways and Escalators



WARNING!

Risk of Injury, Damage or Death

Improper use on stairways and escalators may cause injury, damage or death.

- DO NOT attempt to move an occupied wheelchair between floors using a stairway or escalator.
- DO NOT attempt to move an empty power wheelchair between floors using an escalator.
- Observe and follow all safety warnings.
- Use instructions provided for safe transportation between floors.



WARNING!

Risk of Injury or Damage

Improper lifting technique may cause injury or damage.

- Use proper lifting techniques, assistance and gear such as straps when available when lifting heavy loads.



When using a stairway to move the wheelchair and any accessories, move all wheelchair components away from the stairway prior to reassembly.

- Use an elevator or other accepted safe means of transportation between floors.
- Extreme caution is advised when it is necessary to move an unoccupied power wheelchair up or down the stairs.
- Follow this procedure for moving the wheelchair between floors when an elevator is NOT available:
 1. If stairway or escalator is only means of access, remove occupant of wheelchair and transport user and wheelchair separately.
 2. Invacare recommends using two attendants and making thorough preparations prior to transportation.
 3. Ensure that only secure, non-detachable parts are used for hand-hold supports.
 4. Use safe lifting techniques.
 5. Using non-removable (non-detachable) parts of the wheelchair, lift the wheelchair off of the ground and transfer the wheelchair up or down the stairs.

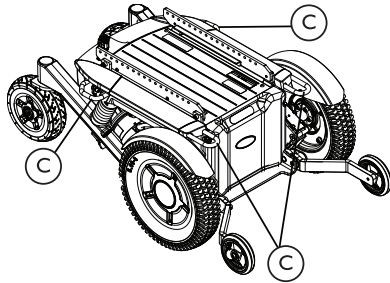

Use the transport brackets © for lifting/handhold locations.

- The wheelchair should not be lowered until the last stair has been negotiated and the wheelchair has been carried away from the stairway.

6.2 Stability and Balance

To assure stability and proper operation of your wheelchair, you **MUST** at all times maintain proper balance. Your wheelchair has been designed to remain upright and stable during normal daily activities as long as you **DO NOT** move beyond the center of gravity. **DO NOT** lean forward out of the wheelchair any further than the length of the armrests.

The drive behavior initially experienced by the user may be different from other wheelchairs previously used. This power wheelchair has Invacare's SureStep® technology, a feature that provides the wheelchair with optimum traction and stability when driving forward over transitions and thresholds. Refer to *Chapter 13 Technical Data, page 92* for maximum height of transitions and thresholds. For more information about approaching obstacles refer to *6.2.2 Safety Information When Approaching Obstacles, page 39* and *Chapter 6.2.3 The Correct Way to Approach Obstacles, page 40*.



WARNING!

Risk of Injury, Damage or Death

Improper use of wheelchair may cause instability and may result in injury, damage or death. The stability of the wheelchair is adversely affected by additional weight that shifts the center of gravity.

- This wheelchair has been designed to accommodate one individual. **DO NOT** operate with additional person(s).
- DO NOT** carry heavy objects on your lap while operating the wheelchair.

**WARNING!****Risk of Injury or Damage**

Improper position and activity, such as reaching, bending or transferring may change the normal balance, center of gravity or weight distribution of the wheelchair causing injury or damage.

- Observe and follow all instructions and warnings regarding reach, weight, balance and positioning.
- Determine and establish your particular safety limits. Practice bending, reaching and transferring activities in several combinations in the presence of a qualified healthcare professional before attempting active use of the wheelchair.
- DO NOT move beyond the center of gravity.
- DO NOT lean forward out of the wheelchair any further than the length of the armrests.
- DO NOT attempt to reach objects if you have to move forward in the seat or pick them up from the floor by reaching down between your knees.
- DO NOT shift your weight or sitting position toward the direction you are reaching.
- DO NOT stand on the frame of the wheelchair.
- DO NOT lean over the top of the back of the wheelchair.

6.2.1 Driving Surfaces**WARNING!****Risk of Injury, Damage or Death**

Loss of traction or stability on rough or unstable terrain may cause injury, damage or death.



- Use care when operating the wheelchair on rough or unstable terrain. This would include but is not limited to areas of rock, mulch, mud, uneven pavement, roots and similar conditions.
- Be aware of your surroundings and conditions that might affect the ability to operate the wheelchair.

Your power wheelchair has been designed to operate on firm, dry, level surfaces (such as, interior floors, concrete and asphalt). Other acceptable surfaces likely to be encountered include packed soil, grass, and gravel.



Do not operate the wheelchair in any type or depth of water (edges of streams, lakes, or oceans.)

If you approach an unfamiliar surface and feel uneasy about driving on that surface, avoid that surface.

6.2.2 Safety Information When Approaching Obstacles

Approach obstacles safely by learning to manage your wheelchair. Keep in mind your center of gravity to maintain stability and balance.

While the wheelchair is designed for use primarily in and around the home, the provider should determine whether this wheelchair is suitable for the actual environment in which the wheelchair will be used.



WARNING!

Risk of Injury, Damage or Death

- Loss of traction or stability on curbs/obstacles may cause injury, damage or death.
- DO NOT cross curbs/obstacles that are not suitable for wheelchairs.
- DO NOT attempt to pass curbs/obstacles that are greater than the maximum climbable obstacle height.
- Follow all instructions regarding negotiating curbs, obstacles and inclines.



Maximum climbable obstacle height is listed in *Chapter 13 Technical Data, page 92.*



CAUTION!

Risk of Injury or Damage

- The wheelchair may tip over if obstacles are not approached correctly.
- Always approach obstacles straight on. Never approach at an angle, as shown in the following image.
- Approach obstacles followed by a gradient with caution. If unsure whether the gradient is too steep or not, move away from the obstacle and if possible try to find another location.
- Put your backrest into an upright position before ascending an obstacle.



CAUTION!

Risk of Injury or Damage

- There is a risk of falling out of the mobility device if obstacles are not approached correctly. There is also a risk of damage to the mobility device, such as broken casters.
- Never approach obstacles that are higher than the maximum climbable obstacle height.
- Never let the footrest/legrest touch the ground when descending an obstacle.
- If unsure whether taking an obstacle is possible or not, move away from the obstacle and if possible find another location.

6.2.3 The Correct Way to Approach Obstacles



The following instructions for approaching obstacles also apply to attendants if the mobility device is equipped with an attendant control.

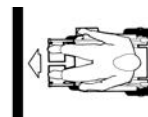

Fig. 6-1 Right



Fig. 6-2 Wrong

Ascending (Going Up) Obstacles

1. Move the backrest into an upright position and lower the seat to the lowest position using the powered seating

functions, if equipped.



2. Approach the obstacle or the curb slowly, head-on and at a right angle (or 90°) to the obstacle.
3. Approach slowly and keep at a consistent forward speed until the rear wheels have also passed over the obstacle.

Descending (Going Down) Obstacles

The approach to descend an obstacle is the same as to ascend it, with the difference that you do not need to stop before descending.

1. Descend the obstacle with medium speed.
 -  Descending an obstacle too slowly could cause the anti-tippers to get stuck and lift the drive wheels off the ground. Driving the mobility device is then no longer possible.

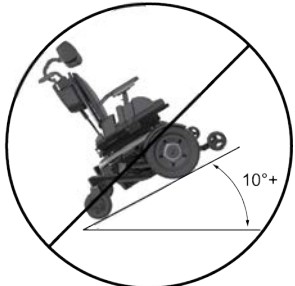
6.2.4 Negotiating Inclines

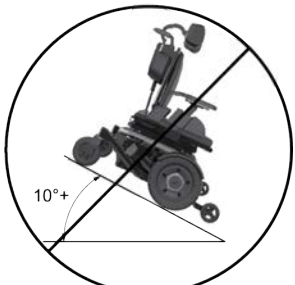
Acceptable Incline Angles 0° to 9°	Avoid Inclines of 10° and above
 <p data-bbox="938 543 1024 565"><i>Fig. 6-3</i></p>	 <p data-bbox="1289 554 1375 576"><i>Fig. 6-4</i></p>
 <p data-bbox="938 946 1024 968"><i>Fig. 6-5</i></p>	 <p data-bbox="1289 935 1375 957"><i>Fig. 6-6</i></p>

**WARNING!****Risk of Injury, Damage or Death**

Loss of traction or stability on inclines/grades or ramps may cause injury, damage or death. Lighter weight users may be at an increased risk. Surfaces that may be wet, icy, oily, slippery, painted, treated wood, rotten wood, rusted metal or other similar surfaces or materials may also increase risk.

- DO NOT use on inclines or ramps where surface is uncertain or compromised.
- DO NOT use on inclines greater than nine (9) degrees.
- DO NOT operate the seating system while on an incline. Operation on an incline may result in increased instability.
- To determine and establish your particular safety limits, practice use of this product on various sloping surfaces in the presence of a qualified healthcare provider before attempting active use of this wheelchair.
- DO NOT use on inclines where line of sight is impaired.
- Travel at a reduced, constant speed and DO NOT make sudden stops or direction changes. Release the joystick and allow the wheelchair to come to a full stop before changing directions. Traveling at high speeds reduces traction and increases stopping distance.

**WARNING!****Risk of Injury, Damage or Death**

Loss of traction or stability on inclines/grades or ramps may cause injury, damage or death. Lighter weight users may be at an increased risk. Surfaces that may be wet, icy, oily, slippery, painted, treated wood, rotten wood, rusted metal or other similar surfaces or materials may also increase risk.

- DO NOT drive in an elevated position while on an incline.
- DO NOT leave elevating legrests in the fully extended position when proceeding down inclines/grades.
- DO NOT leave an unoccupied wheelchair unattended on inclines or ramps.

**DANGER!****Risk of Death or Serious Injury**

Traveling down inclines in reverse could cause the wheelchair to tip over resulting in death or serious injury

- DO NOT travel down inclines in reverse.

6.2.5 Reaching, Leaning and Bending - Forward

Many activities require the wheelchair user to reach, bend and transfer in and out of the wheelchair. These movements will cause a change to the normal balance, center of gravity, and weight distribution of the wheelchair. To determine and establish your particular safety limits, practice bending, reaching and transferring activities in several combinations in the presence of a qualified healthcare professional before

attempting active use of the wheelchair



1. Engage motor locks.
2. Turn power off.
3. Position the casters so that they are parallel to the drive wheels to create the longest possible wheelbase.
4. Reach, lean or bend only as far as your arm will extend without changing your sitting position.

6.2.6 Reaching, Leaning and Bending - Backward



1. Position wheelchair as close as possible to the desired object.
2. Position the casters so that they are parallel to the drive wheels to create the longest possible wheelbase.
3. Engage the motor locks.
4. Turn power off
5. Reach back only as far as your arm will extend without changing your sitting position.

6.2.7 Transferring To and From Other Seats



WARNING!

Risk of Serious Injury or Damage

Improper transfer techniques may cause serious injury or damage.

- Before attempting transfers, consult a health care professional to determine proper transfer techniques for the user and type of wheelchair.



WARNING!

Risk of Injury or Damage

Misuse of footplate may cause injury or damage.

- DO NOT stand on footplates.
- Ensure the footplates are in the upward position or swung outward when getting in or out of the wheelchair.



Fig. 6-7 Front View

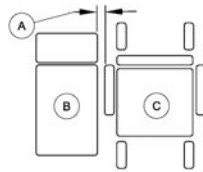

Fig. 6-8 Top View



Adequate mobility and upper body strength is required to perform this activity independently.

1. Transfer to and from the wheelchair in the presence of a qualified healthcare professional to determine individual safety limits.
2. Turn power button OFF BEFORE entering or exiting the wheelchair.
3. Reduce gap between transfer surface (B) and wheelchair seat (C) to the minimum distance (A) necessary to perform transfer.
4. ALWAYS engage both motor locks and wheel hubs (if equipped) to prevent the wheels from moving before transferring into or from the wheelchair.
5. Align casters parallel to the drive wheels to improve stability during transfer.

6. Invacare strongly recommends ordering the optional wheel locks as an additional safeguard if not present.
7. Flip up footplates or swing footrests outward.
8. Shift body weight into seat with transfer



During independent transfer, little or no seat platform will be beneath you. Use a transfer board if at all possible.

6.3 Weight Training and Other Activities



WARNING!

Risk of Injury or Damage

Invacare DOES NOT recommend the use of its wheelchairs as a weight training apparatus. Invacare wheelchairs have NOT been designed or tested as a seat for any kind of weight training. Using said wheelchair for weight training could result in serious bodily injury to the user, damage to the wheelchair and surrounding property. Also, if occupant uses said wheelchair as a weight training apparatus, Invacare shall NOT be liable for bodily injury and the warranty is void.
-DO NOT use the wheelchair as a weight training apparatus.

**WARNING!****Risk of Injury or Damage**

Misuse of the wheelchair may result in injury or damage.

- DO NOT use the wheelchair for stretching exercises.
- DO NOT use the wheelchair to perform wheelies.

6.4 Pushing the Mobility Device in Freewheel Mode

The motors of the mobility device are equipped with motor locks, which prevent the mobility device from rolling when the remote is switched off. When pushing the mobility device manually while freewheeling, the motor locks must be disengaged.



Pushing the mobility device by hand may require more physical force than expected (more than 100 N). The necessary force nevertheless complies with the requirements of ISO 7176-14.



The intended use of the freewheel mode is to maneuver the mobility device over short distances. The push handles or push bars support this function, but be aware that there might be some interference between the feet of the assistant and the rear part of the mobility device.

6.4.1 Disengaging/Engaging the Motor Locks

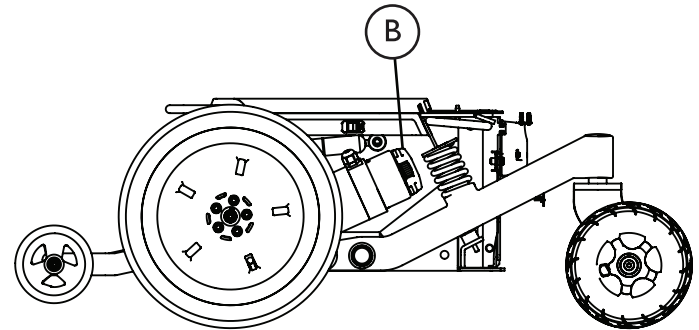
**WARNING!****Risk of Injury or Damage**

Misuse of motor locks may result in injury or damage.
-DO NOT engage or disengage motor locks until the power is in the off position.



Motor lock **B** disengagement/engagement allows free-wheeling or joystick controlled operation. Free-wheeling allows an assistant to maneuver the wheelchair without power. Motor locks are located on the end of the motor behind the drive wheel on both sides of the wheelchair.

1. Turn off the wheelchair power.
2. Perform one of the following as if viewing the motors from

behind the wheelchair (Detail “A”):

- Disengage (PUSH) - Rotate the motor locks UP to disengage the motors and push the wheelchair.
- Engage (DRIVE) - Rotate the motor locks DOWN to engage the motors and drive the wheelchair.

7 Controls System

7.1 Electrical



DANGER!

Risk of Death or Serious Injury

Electric shock can cause death or serious injury.
 -To avoid electric shock, inspect plug and cord for cuts and/or frayed wires. Replace cut cords or frayed wires immediately.



WARNING!

Power wheelchairs are equipped with three-prong (grounding) plugs for protection against possible shock hazards. Where a two-prong wall receptacle is encountered, it is the personal responsibility and obligation of the customer to contact a qualified electrician and have the two-prong replaced with a properly grounded three-prong wall receptacle in accordance with the National Electrical code. If you must use an extension cord, use only a three-wire extension cord having the same or higher electrical rating as the device being connected. **DO NOT**, under any circumstances, cut or remove the round grounding prong from any plug used with or for Invacare products. In addition, Invacare has placed **RED** warning tags on some equipment. **DO NOT** remove these tags.



DANGER!

Risk of Death, Injury or Damage

Shock hazards and risk of fire exist due to use of improper extension cord and/or use of three prong adapters.

- To avoid injury or product damage, when using an extension cord, use only a UL approved three wire extension cord having at least 16 AWG (American Wire Gauge) wire and the same or higher electrical rating as the device being connected.
- DO NOT** use three prong to two prong adapters.

7.2 Controls Protection System

The wheelchair controls system is equipped with an overload protection.

If the drive is severely overloaded over a long period of time (for example, when driving up a steep hill) and especially when the ambient temperature is high, the controls system could overheat. In this case, the wheelchair performance is gradually reduced until it stops. The status display shows a corresponding error code (refer to the user manual for your remote). By switching the power supply off and back on again, the error code is cleared and the controls system is switched back on. It can however take up to five minutes until the controls system has cooled down enough for the drive to restore full performance again.

If the drive is stalled by an insurmountable obstacle, for example, a curb or similar which is too high, and the driver attempts driving for more than 20 seconds against this obstacle, the controls system automatically switches off to prevent the motors from being damaged. The status display shows a corresponding error code (refer to the user manual of your remote). By switching off and back on again, the error code is cleared and the controls system is switched back on.

- ⓘ A defective main fuse may be replaced only after checking the entire controls system. A specialized Invacare provider must perform the replacement. You can find information on the fuse type in *Chapter 13 Technical Data, page 92*.

7.3 Using the Battery Isolation Switch

- ⓘ The battery isolation switch must not be used as an ON/OFF button. When the battery isolation switch is used, the LiNX system could lose information like the correct time to display on the remote.
- ⓘ There is no need to use the battery isolation switch when transporting the mobility device in a vehicle.
- ⓘ The mobility device cannot be charged when the battery isolation switch is switched off.

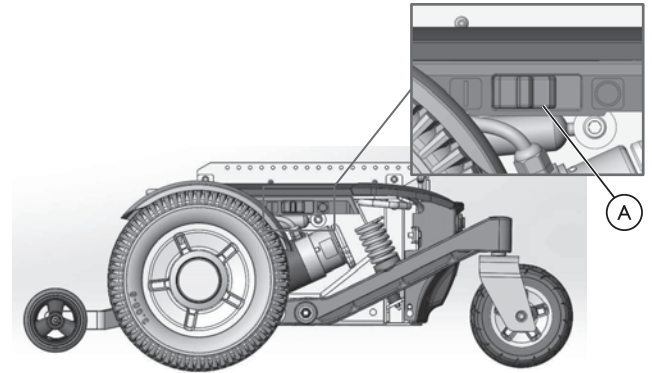

The battery isolation switch Ⓐ is located on the left side of the battery box.

The battery isolation switch is an additional safety feature of the controls protection system. When the system is overloaded, the battery isolation switch switches off automatically. In a hazardous situation or when the mobility device starts to behave erratically, the battery isolation switch can be used to isolate the battery source quickly.

Also, it can be used to switch off the power supply of your mobility device manually, when the mobility device is transported without surveillance, for example while traveling in a plane. Refer to *2.5 Travel Information, page 12*.

Use the battery isolation switch Ⓐ to disconnect the power.

- Disconnect (O) — Push the switch towards the BACK of the wheelchair. The power will turn off.
- Connect (I) — Push the switch towards the FRONT of the wheelchair. The power will turn on.

7.4 Batteries

Power is supplied by two 12 V batteries. The batteries are maintenance-free and only need regular charging. In the following, you find information on how to charge, handle, transport, store, maintain, and use batteries.

7.4.1 General Information on Charging

New batteries should always be fully charged once before their first use. New batteries will be at their full capacity after having run through approximately 10 - 20 charging cycles (break-in period). This break-in period is necessary to fully activate the battery for maximum performance and longevity. Thus, range and running time of your mobility device could initially increase with use. Gel/AGM lead acid batteries do not have a memory effect like NiCd batteries.

7.4.2 General Instructions on Charging

Follow the instructions listed below to ensure safe use and longevity of the batteries:

- Charge 18 hours prior to initial usage.
- We recommend charging the batteries daily after every discharge even after partly discharge, as well as overnight. Depending on the level of discharge, it can take up to 12 hours until the batteries are fully charged again.
- When the battery indicator reaches the red LED range, charge the batteries for at least 16 hours, even if the display reads that the charge is complete.
- Try to provide a 24 hour charge once a week to make sure that both batteries are fully charged.
- Do not cycle your batteries at a low state of charge without regularly recharging them fully.
- Do not charge your batteries under extreme temperatures. High temperatures above 86 °F (30 °C) are not recommended for charging as well as low temperatures below 50 °F (10 °C).
- Use only charging devices in Class 2. This class of chargers may be left unattended during charging. All charging devices which are supplied by Invacare comply with these requirements.
- You cannot overcharge the batteries when using the charger supplied with your mobility device, or a charger that has been approved by Invacare.

- Protect your charger from sources of heat such as heaters and direct sunlight. If the battery charger overheats, charging current will be reduced and the charging process delayed.

7.4.3 How to Charge the Batteries

Refer to the user manuals for your remote and battery charger for the position of the charging socket and further information about charging the batteries.



WARNING!

Risk of Injury or Damage

Using the wrong battery charger may cause explosion and destruction of batteries. To avoid injury or damage:

- Only use the battery charger supplied with your mobility device, or a charger that has been approved by Invacare.



WARNING!

Risk of Injury, Damage or Death

- Improper charging may cause injury or damage.
- Charge battery in a cool, dry and well-ventilated area.
 - DO NOT attempt to charge the battery by attaching cables directly to the battery terminals.
 - DO NOT attempt to charge the battery and operate the wheelchair at the same time.
 - DO NOT attempt to charge the battery when the wheelchair has been exposed to any type of moisture.
 - DO NOT sit in the wheelchair while charging the battery.
 - DO NOT leave the charger unattended when the breaker has tripped. Unplug and discontinue use immediately. Contact a qualified service technician or Invacare for service.



WARNING!

Risk of Injury or Damage

- Explosive gases can be generated while charging. To avoid flammable gas buildup and injury or damage due to explosion:
- During charging, keep the wheelchair and battery charger away from sources of ignition, such as flames and sparks.
 - Charge the wheelchair in a space at least twice the volume of the wheelchair.

**WARNING!**

Risk of short circuit and electric shock if the battery charger has been damaged

-Do not use the battery charger if it has been dropped or damaged.

**WARNING!**

Risk of Injury, Damage or Death

Improper routing of cord(s) may cause tripping, entanglement or strangulation hazard that may result in injury, damage or death.

-Ensure all cord(s) are routed and positioned properly while charging.

-Avoid positioning cord(s) across areas of high foot traffic (i.e. aisles, doorways, hallways, etc.) while charging.

-Close supervision and attention is needed when operating the wheelchair near children, pets or people with physical/mental disabilities.

1. Perform one of the following

- Charging NEW batteries—Ensure the mobility device power is ON.



The wheelchair power must be on to ensure that accurate battery charge levels display on the remote. New batteries must be charged fully. This includes on initial delivery and after battery replacement. The Battery Synchronization Procedure **MUST** be performed within 24 hours of powering on the wheelchair. The Battery Synchronization Procedure can be found in the LiNX service manual and must be performed by a provider or qualified technician.

- Charging existing batteries—Switch off the mobility device.

2. Connect the battery charger to the charger socket.



The charger connector pins are identified in the following ways:

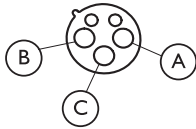

- Pin 1 (A) — Battery Plus (+)
- Pin 2 (B) — Battery (-)
- Pin 3 (C) — Inhibit

3. Connect the battery charger to the power supply.

7.4.4 How to Disconnect the Mobility Device After Charging

1. Once charging is complete, disconnect the battery charger from the power supply.
2. Disconnect the plug from the remote.

7.4.5 Storage and Maintenance

Follow the instructions listed below to ensure safe use and longevity of the batteries:

- Always store the batteries fully charged.
- Do not leave the batteries in a low state of charge for an extended length of time. Charge a discharged battery as soon as possible.
- In case your mobility device is not used for a longer period of time (that is more than two weeks), the batteries must be charged at least once a month to maintain a full charge and always be charged before use.
- Avoid hot and cold extremes when storing. We recommend to store batteries at a temperature of 59°F (15 °C).
- Gel and AGM batteries are maintenance-free. Any performance issues should be handled by a properly trained mobility device technician.

7.4.6 Using the Proper Batteries



WARNING!

Risk of Injury or Damage

Improper configuration of battery terminals may cause injury or damage.

- Batteries with terminal configuration as shown **MUST** be used.
- The POSITIVE (+) battery cable **MUST** connect to the POSITIVE (+) battery terminal.
- The NEGATIVE (-) battery cable **MUST** connect to the NEGATIVE (-) battery terminal.
- DO NOT allow any of your tools and/or battery cables

 to contact both battery terminals at the same time.



CAUTION!
Risk of Damage

Use of wrong battery type or size may cause damage.
-DO NOT force a battery into place.
-Batteries with molded straps or flanges that interfere with proper battery placement should not be used.
-Use batteries listed in this manual for proper replacement.



Failure to use the correct battery size and/or voltage may cause damage to your wheelchair and give you unsatisfactory performance. The warranty and performance specifications contained in this manual are based on the use of deep cycle gel cell batteries. Invacare strongly recommends their use as the power source for this unit.

Carefully read battery/battery charger information prior to installing, servicing or operating your wheelchair.

1. Position battery on ground/flat surface as shown below.
2. Visually inspect the battery to ensure proper polarity:

FOR WHEELCHAIRS USING GP24 BATTERIES

Batteries with terminal configuration (POSITIVE **A** on the right and NEGATIVE **B** on the left) as shown below MUST be used. Batteries that have the reverse terminal configuration MUST not be used - otherwise injury and damage may occur.

PROPER BATTERIES TO USE

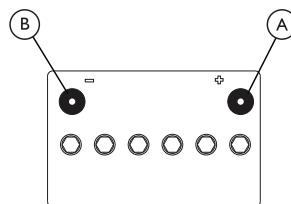

DO NOT USE THIS TYPE OF BATTERY

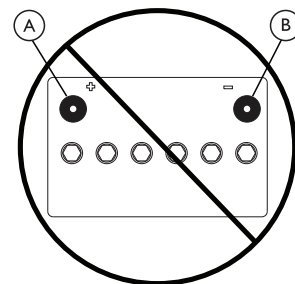

7.4.7 Instructions on Using the Batteries



CAUTION!
Risk of Damage

Draining your batteries to extremely low levels of charge can cause battery damage. To avoid damaging the batteries:

- Charge the batteries regularly.
- Never drain your batteries completely.

- Pay attention to the Battery Charge Indicator! Charge the batteries when the Battery Charge Indicator shows that battery charge is low. How fast the batteries discharge depends on many circumstances, such as ambient temperature, condition of the surface of the road, tire pressure, weight of the driver, way of driving and utilisation of lighting, if equipped.
 - Try to charge the batteries always before you reach the red LED range. The last 3 LED (one red and two orange) mean you have a remaining capacity of about 15%.
 - Driving with flashing red LED's means an extreme stress for the battery and should be avoided under normal circumstances.
 - When only one red LED is flashing, the Battery Safe feature is enabled. From this time, speed and acceleration is reduced drastically. It will allow you to move the mobility device slowly out of a dangerous situation before the electronic finally cuts off. This is deep discharging and should be avoided.
 - Be aware that for temperatures below 68°F (20°C), the nominal battery capacity starts to decline. For example, at 14°F (-10°C) the capacity is reduced to about 50% of the nominal battery capacity.
 - To avoid damaging the batteries, never allow them to be fully discharged. Do not drive on heavily discharged batteries if it is not absolutely necessary, as this will strain the batteries unduly and shorten their life expectancy.
 - The earlier you recharge the batteries, the longer they live.
 - The depth of discharge affects the cycle life. The harder a battery has to work, the shorter is its life expectancy. Examples:
 - One deep discharge stresses the same as 6 normal cycles (green /orange display off).
 - The battery life is about 300 cycles at 80% discharge (first 7 LED off), or about 3000 cycles at 10% discharge (one LED off).
-  The number of LED can vary depending on the remote type.
- Under normal operation, once a month the battery should be discharged until all green and orange LED are off. This should be done within one day. A 16 hour charge afterwards is necessary as reconditioning.

7.4.8 Transporting Batteries

The batteries supplied with your mobility device are not hazardous goods. This classification is based on the German GGVS Hazardous Goods Road Transport Ordinances, and the IATA/DGR Hazardous Goods Rail Transport / Air Transport Ordinances. Batteries may be transported without restrictions, whether by road, rail or by air. Individual transport companies have, however, guidelines which can possibly restrict or forbid certain transport procedures. Please ask the transport company regarding each individual case.

7.4.9 General Instructions on Handling the Batteries

- The batteries reach their end of life when the drive range is significantly smaller than usual. Contact your provider or service technician for details.
- Always have your batteries installed by a properly trained mobility device technician or a person with adequate knowledge. They have the necessary training and tools to do the job safely and correctly.

8 Transport - ISO 7176-19

This chapter covers products that adhere to ISO 7176-19. Refer to the labeling on your product to determine the applicable standard and proper instructions to follow.

8.1 Wheelchair Transport Brackets (TRBKTS)

As of this date, the Department of Transportation has not approved any tie-down systems for transportation of a user while in a wheelchair, in a moving vehicle of any type. It is Invacare's position that users of wheelchairs should be transferred into appropriate seating in vehicles for transportation and use be made of the restraints made available by the auto industry. Invacare cannot and does not recommend any wheelchair transportation system.

TRBKTS includes four factory-installed wheelchair transport brackets.

TRBKTS wheelchair models and configurations may not be used as a vehicle seat and are identified by the following label on the device:



WARNING!

Risk of Injury, Damage or Death

Improper use of wheelchair transport brackets (TRBKTS) may result in injury, damage or death. The wheelchair or its parts may become airborne during a sudden vehicle stop or accident and injure vehicle occupants or cause damage.

- Use these transport brackets only to secure an unoccupied wheelchair during transport.
- Ensure wheelchair is secured using proper restraint systems. Wheelchair transport brackets have not been crash-tested in accordance with ISO 7176-19.
- Only use the transport brackets for the purposes described in this manual.

8.2 Transport Ready Option (TRRO)

As of this date, the Department of Transportation has not approved any tie-down systems for transportation of a user while in a wheelchair, in a moving vehicle of any type. It is Invacare's position that users of wheelchairs should be transferred into appropriate seating in vehicles for transportation and use be made of the restraints made available by the auto industry. Invacare cannot and does not recommend any wheelchair transportation system.

**WARNING!****Risk of Injury, Damage or Death**

Failure to observe and follow transport warnings and instructions may result in injury, damage or death.
-Only use the transport brackets included with TRRO for the purposes described in this manual.

There are two Transport Ready Options available:

- TRRO — For wheelchairs without the elevate option. TRRO includes four factory-installed transport brackets.
- TRRO-E — For wheelchairs with the elevate option. TRRO-E includes six factory-installed transport brackets.

Both Transport Ready Options rely on vehicle anchored pelvic and upper-torso belts.

- The wheelchair has been tested for seating in a motor vehicle with the factory installed seating system only.
- This wheelchair has been dynamically tested in a forward-facing mode with the specified crash test dummy restrained by BOTH pelvic and upper-torso belt(s) (shoulder belts), and that BOTH pelvic and upper torso belt (s) should be used to reduce the possibility of head and chest impacts with vehicle components.

- Transport Ready Options have been crash-tested in accordance with ISO 7176–19.
- The wheelchair is identified by the following label:



ISO 7176-19

8.3 Transport—General information

**WARNING!****Risk of Injury, Damage or Death**

Alteration or substitution may result in injury, damage or death.
-DO NOT alter or substitute product parts, components or systems.

**CAUTION!****Risk of Injury or Damage**

Transporting a mobility device in a vehicle with a tray installed may cause injury or damage.
-If a tray is installed, always remove it before transporting the mobility device.

8.4 Transferring Mobility Device to Vehicle



WARNING!

The mobility device is at risk of tipping over if it is transferred to a vehicle while the user is still seated in the mobility device

- Transfer the mobility device without the user whenever possible.
- If the mobility device with the user has to be transferred to a vehicle using a ramp, ensure the ramp is properly secured. Refer to the ramp instructions. Ensure that the ramp does not exceed the rated slope (refer to *Chapter 13 Technical Data, page 92*).
- If the mobility device has to be transferred to a vehicle using a ramp that does exceed the rated slope (refer to *Chapter 13 Technical Data, page 92*), a winch (a chain or wire rope attached to a drum with a crank) must be used to transfer the wheelchair into the vehicle. Ensure the winch has a rated weight capacity greater than the weight of the wheelchair. Refer to the winch instructions. An attendant can then safely monitor and assist the transfer process.



WARNING!

The mobility device is at risk of tipping over if it is transferred to a vehicle while the user is still seated in the mobility device

- Alternatively, a platform lift may be used.
- Ensure that the total weight of the mobility device including the user does not exceed the maximum permitted total weight for the ramp or platform lift.
- The mobility device should always be transferred to a vehicle with the backrest in an upright position, the seat lifter lowered and the seat tilt in the upright position.



WARNING!

Risk of injury and damage to the mobility device

- If the mobility device is to be transferred to a vehicle via a lift, when the remote is turned on, there is a risk that the device may act erratically and fall off the lift.
- Before transferring the mobility device via a lift, turn off the product and disconnect either the bus cable from the remote or the batteries from the system.

1. Drive or push your mobility device into the transport vehicle using a suitable ramp.

8.5 Use of the Mobility Device as a Seat in a Vehicle



The following section does not apply to models or configurations which may not be used as a vehicle seat. These are identified by the following label on the mobility device:

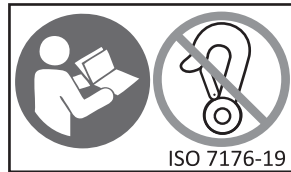

WARNING!

Risk of death or serious injury

If a mobility device is secured using a 4-point (non-elevate systems) or 6-point (elevate systems) tie-down system available from a third party supplier and the curb weight of the mobility device exceeds the maximum weight for the system, death or serious injury to the user and potential nearby occupant.

- The actual weight of this mobility device can exceed 309 lb (140 kg). Make sure to use a 4-point or 6-point tie-down system checked and approved in accordance with ISO 10542 and certified for the actual weight of the mobility device. Consult the tie-down system manufacturer's documentation.



WARNING!

Risk of injury

Safety restraint devices must only be used when the wheelchair user's weight is 14 lb (22kg) or more.

- When the user weight is lower than 14 lb (22kg), do not use the wheelchair as a seat in a vehicle.



CAUTION!

There is a risk of injury if the mobility device is not properly secured during use as a vehicle seat.

- If possible, the user should always leave the mobility device to use a vehicle seat and the safety belts provided with the vehicle.
- The mobility device should always be anchored facing in the transport vehicle's intended direction of travel.
- The mobility device must always be secured in accordance with the mobility device and anchoring system manufacturers' user manual.
- Always remove and secure any accessory parts fixed to the mobility device such as chin controls or tables.
- If your mobility device is equipped with an angle adjustable backrest, then it must be placed in an upright position.
- Fully lower elevated legrests, if equipped.
- Fully lower the seat lifter, if equipped.



CAUTION!

Risk of injury exists if a mobility device that is not equipped with leak-proof batteries is transported in a vehicle.

-Only ever use leak-proof batteries.



CAUTION!

Risk of injury or damage to the mobility device or to the transporting vehicle, if the legrests are in a raised position while the mobility device is used as a vehicle seat.

-Always completely lower height-adjustable legrests, if equipped.

This mobility device complies with the requirements of ISO 7176-19 and may be used as a vehicle seat in connection with an anchoring system that has been checked and approved in accordance with ISO 10542. The transporting vehicle must be professionally converted to anchor the mobility device. Contact your vehicle's manufacturer for more information. The mobility device has undergone a crash test in which it was anchored in the transporting vehicle's direction of travel. Other configurations were not tested. The crash test dummy was secured using pelvic and upper body safety belts. Both types of safety belt should be used in order to minimize the risk of injuries to head or upper body.

It is imperative that the mobility device is inspected by an Invacare provider before being used again after being involved in a crash. Alterations to the mobility device anchoring points may not be carried out without the manufacturer's permission.

8.5.1 How the Mobility Device is Anchored in a Vehicle

The mobility device is equipped with tie-down points. Snap hooks or belt loops can be used for fixation. If the wheelchair can be used as a vehicle seat, these tie-down points are labelled with the symbol shown on the right.



ISO 7176-19

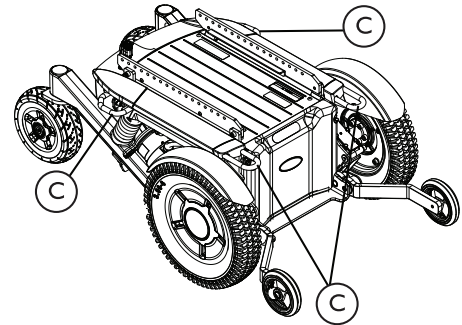

Fig. 8-1 Base Tie-Down Points—All Wheelchairs

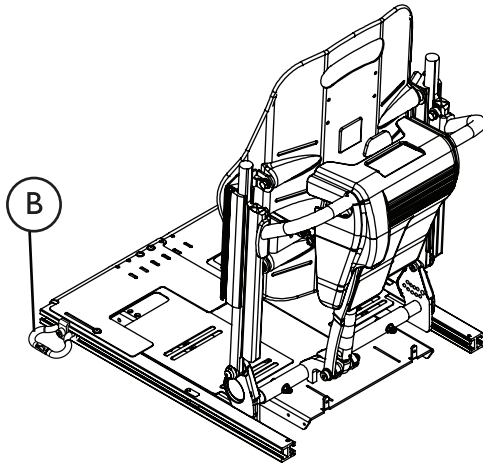

Fig. 8-2 Seat Tie-Down Points—Wheelchairs with Ultra Low Maxx Seats and Elevate

- Secure the mobility device with the tie-down system belts at the following locations:
 All Wheelchairs — four tie down points © on the wheelchair base (two at the front and two at the rear).
 Systems with Ultra Low Maxx Seats and Elevate (TRRO-E) — two additional tie down points ® on either side of the seat at the front of the seat rails.

- Secure the mobility device by tensioning the belts in accordance with the tie-down system manufacturer's user manual.

8.5.2 How The User is Secured Within the Mobility Device



CAUTION!

Risk of injury if the user is not properly secured within the mobility device

- Even if the mobility device is equipped with a posture belt, this is no substitute for a proper safety belt which complies with ISO 10542 in the transport vehicle. Always use the safety belt installed in the transport vehicle.
- Safety belts must be in contact with the user's body. They must not be held at a distance from the user's body using parts of the mobility device such as armrests or wheels.
- Safety belts must be pulled as tightly as possible without causing the user discomfort.
- Safety belts must not be positioned while twisted.
- Ensure that the third seat belt anchorage point is not fixed directly to the vehicle floor, but to one of the vehicle uprights.



CAUTION!

Risk of injury during use of the mobility device as a vehicle seat if a headrest is improperly adjusted or not installed

This can cause the neck to be hyperextended during collisions.

- A headrest must be installed. The headrest optionally supplied for this mobility device by Invacare is perfectly suitable for use during transport.
- The headrest must be adjusted to the user's ear height.

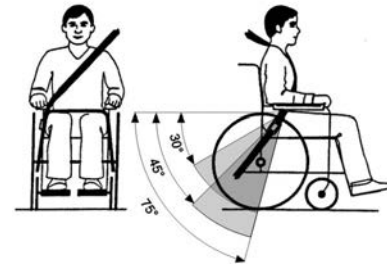

The pelvic belt should be positioned in the area between the user's pelvis and thighs so that it is unobstructed and not too loose. The ideal angle of the pelvic belt to the horizontal is between 45° and 75°. The maximum permissible angle is between 30° and 75°. The angle should never be less than 30°!

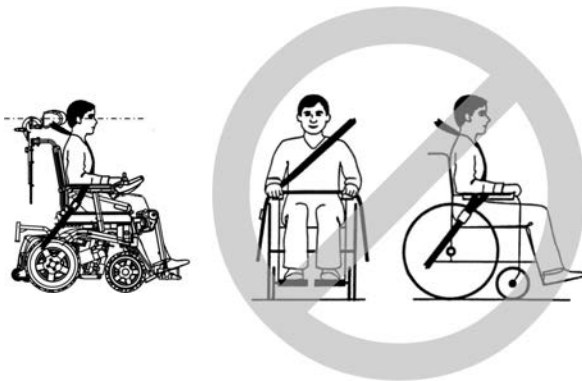

Seat belts may not be held at a distance from the user's body using parts of the mobility device such as armrests or wheels.

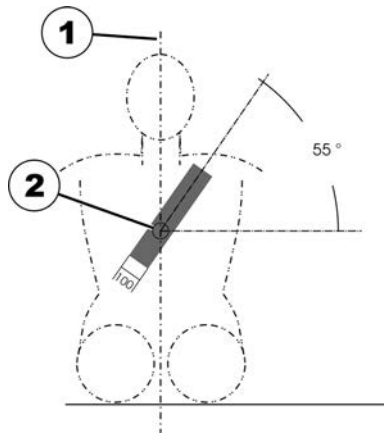

The safety belt installed in the transporting vehicle should be applied as shown in the illustration above.

- 1) Center line of the body
- 2) Center of the sternum

8.6 Transporting the Mobility Device Without Occupant



CAUTION!

Risk of injury

-If you are unable to fasten your mobility device securely in a transport vehicle, Invacare recommends that you do not transport it.

Your mobility device may be transported without restrictions, whether by road, rail or by air. Individual transport companies have, however, guidelines which can possibly restrict or forbid certain transport procedures. Please ask the transport company regarding each individual case.

- Before transporting your mobility device, make sure the motors are engaged and that the remote is switched off. Invacare strongly recommends that you disconnect or remove the batteries.
- Invacare strongly recommends securing the mobility device to the floor of the transporting vehicle.

9 Maintenance

9.1 Wear and Tear Information

General Information

Normal wear and tear items and components include but are not limited to: all upholstery items including seat and back upholstery, arm and calf pads, cushions, wheels, tires and casters, all types of batteries, joystick overlays and inductive rubberized protective boots.

Invacare reserves the right to ask for any item back that has an alleged defect in workmanship. Refer to the Warranty section in this manual for specific warranty information.

Refer to the Inspection Checklists for proper preventative maintenance schedule.

This is just a general guideline and does not include items damaged due to abuse and misuse.

Product Type	Product Wear and Tear
Wheelchairs	Wheels, Brake Assembly, Hand Grips

Mobility Hardware and Electronics	Rubber Urethane Tires and Casters, Handgrips, Joystick Inductive Tops, Joystick Overlays, Motors and Gearboxes (if exposed to prolonged moisture, urine, etc.), Pneumatic Tires and Tubes
Upholstery and Seating	Arm pads, Seat Cushion Foam, Seat Cushion Covers, Back Cushion Foam, Back Cushion Covers, Headrest Foam, Headrest Covers, Footplate Covers, Calf Pad (if applicable) Foam and Cover
Batteries	Lead acid/Lithium, Coin cell (watch type), Gel (6 months)

9.2 User/Attendant Inspection Checklists



Every six months, and as necessary, take your wheelchair to a qualified technician for a thorough inspection and servicing.

Weekly, monthly, and periodic inspections should be performed by user/attendant between the six month Regular cleaning will reveal loose or worn parts and



enhance the smooth operation of your wheelchair. To operate properly and safely, your wheelchair **MUST** be cared for just like any other vehicle. Routine maintenance will extend the life and efficiency of your wheelchair.

**DANGER!****Risk of Injury, Damage or Death**

Overinflation of tires may cause tires to explode.

- Inflate tire to the proper tire pressure (P.S.I. / kilopascals) listed on the side wall of the tire.
- Only use wheelchair with tires at proper pressure.
- The wheels and tires should be checked periodically for cracks and wear and should be replaced if necessary.

9.2.1 Inspect/Adjust Weekly

- Ensure that the casters are free of debris.
- Inspect tires for flat spots and wear.
- Inspect all fasteners.
- Inspect TRRO fasteners and hardware.
- Ensure proper operation of powered functions (Example: drive, seating and legrests).

9.2.2 Inspect/Adjust Monthly

- Clean upholstery and armrests.
- Clean dirt and lint from axles.
- Clean dirt and lint from bearings.
- Ensure that the casters are free of debris.
- Inspect seat positioning strap for any signs of wear. Ensure buckle latches. Verify hardware that attaches strap to frame is secure and undamaged. Replace if necessary.

9.2.3 Inspect/Adjust Periodically

- Ensure wheelchair rolls straight (no excessive drag or pull to one side).
- Inspect all operator (user/attendant) adjustable fasteners including the back pan, back cane and angle adjustment fasteners, and the arm support, flip back and height adjustment fasteners. Ensure fasteners are securely tightened.
- Inspect TRRO fasteners and hardware.
- Ensure clothing guards are secure.
- Ensure arms are secure but easy to release and adjustment levers engage properly.
- Ensure adjustable height arms operate and lock securely.

- Ensure upholstery does not have any rips or tears.
- Ensure armrest pad sits flush against arm tube.
- Ensure that the casters are free of debris.
- Inspect foam handgrips for damage. If damaged, have them replaced by a qualified technician.
- Check center mount front riggings for loose fasteners. Replace /tighten if necessary.
- Check that all labels are present and legible. Replace if necessary.

9.3 Service Inspection Information



Every six months take your wheelchair to a qualified technician for a thorough inspection and servicing. Service inspections MUST be performed by a qualified technician.
TECHNICIANS — Refer to *10.3 Service Inspection, page 73* for service inspection checklists and more information.

9.4 Cleaning



WARNING!

Risk of Injury, Damage or Death

Electrical shock may cause injury, damage or death.
-Always unplug the product from the electrical outlet



before cleaning.

-Always unplug accessories from the electrical outlet before cleaning.



CAUTION!

Risk of Damage

Cleaning or maintenance may cause damage to carpeting or flooring.

-Place the wheelchair in a well ventilated area where cleaning or maintenance can be performed without risk of damage to carpeting or flooring.



CAUTION!

Risk of Damage

Exposure to liquids may damage components or accessories of wheelchair and electronics.

-DO NOT spray with any type of water or liquid.
-Electrical components damaged by corrosion MUST be replaced immediately.



WARNING!

Risk of Injury, Damage or Death

Excessive moisture or cleaning may reduce the flame retardancy of the upholstery and may result in injury, damage or death.

-Follow all cleaning instructions.
-Avoid excessive moisture or cleaning.



Regular cleaning will reveal loose or worn parts and enhance the smooth operation of your wheelchair. To operate properly and safely, your wheelchair must be cared for just like any other vehicle.

For upholstery that is severely stained or surface finish that is badly damaged, contact Invacare for further information.

1. Use the following instructions to clean this product unless otherwise specified.
 - Upholstery — Warm water and mild non-abrasive soap.
 - Metal — Hot water and mild non-abrasive soap. Car polish and soft wax may be used to remove abrasions and restore gloss.
 - Plastic — Hot water and mild non-abrasive soap.
2. Dry the surface with dry cloth.
3. DO NOT use solvents or kitchen cleaners.

9.5 Wheels and Tires

9.5.1 Damaged Wheels

In case of having a damaged wheel, contact your provider. For safety reasons, do not repair the wheel yourself or have the wheel repaired by unauthorized persons.

9.5.2 Pneumatic Tires



DANGER!

Risk of Injury, Damage or Death

Overinflation of tires may cause tires to explode.

- Inflate tire to the proper tire pressure (P.S.I. / kilopascals) listed on the side wall of the tire.
- Only use wheelchair with tires at proper pressure.
- The wheels and tires should be checked periodically for cracks and wear and should be replaced if necessary.



Risk of damage to tire and rim

Never drive with under-inflated tires, this could result in damage to tire.

- If tire pressure is exceeded rim could be damaged.
- Inflate tires to recommended pressure.



Use tire gauge to check pressure.

Check weekly that the tires are inflated to the correct pressure, see 9.2 *User/Attendant Inspection Checklists*, page 64.

For recommended tire pressure see inscription on tire/rim or contact Invacare. Compare table below for conversion.

psi	bar
22	1.5
23	1.6

psi	bar
25	1.7
26	1.8
28	1.9
29	2.0
30	2.1
32	2.2
33	2.3
35	2.4
36	2.5
38	2.6
39	2.7
41	2.8
44	3.0

10 Service

10.1 Safety Information



This section of the user manual provides service instructions for this product. All procedures in this section **MUST** be performed by a qualified technician/provider.

-USERS/CAREGIVERS — If necessary, contact Invacare for a list of providers.

-PROVIDERS/TECHNICIANS — For any service requirements beyond these procedures, refer to the online service manual at www.invacare.com or contact Invacare.

-PROVIDERS/TECHNICIANS — For parts information, refer to the parts catalog at www.invacare.com or contact Invacare.

-PROVIDERS/TECHNICIANS — **DO NOT** return product without first contacting your provider/Invacare for shipping and packing instructions.



Performing procedures in this section may require the use of tools including:

Flat blade and Phillips® screwdrivers, standard and/or metric sockets/wrenches, torque wrench, and hex (Allen) keys.

10.1.1 Set Up



DANGER!

Risk of Death, Serious Injury, or Damage

Continued use of the wheelchair that is not set to the correct specifications may cause erratic behavior of the wheelchair resulting in death, serious injury, or damage.

-Performance adjustments should only be made by professionals of the healthcare field or persons fully conversant with this process and the driver's capabilities.

-After the wheelchair has been set up/adjusted, check to make sure that the wheelchair performs to the specifications entered during the set up procedure. If the wheelchair does not perform to specifications, turn the wheelchair Off immediately and reenter set up specifications. Stop using the wheelchair, and contact Invacare, if wheelchair still does not perform to correct specifications.



WARNING!

Risk of Serious Injury or Damage

Moving the seating system from the factory setting may reduce driver control, wheelchair stability, traction and increase caster wear resulting in serious injury or damage.

- Move the seating system ONLY when necessary to fit the wheelchair to the user.
- If the seating system must be moved, ALWAYS inspect the wheelchair to ensure the front rigging DOES NOT interfere with the front casters.
- If the seating system must be moved, ALWAYS inspect to ensure the wheelchair DOES NOT easily tip forward or backward.



WARNING!

Risk of Injury, Damage or Death

Improper routing of cable(s) may cause tripping, entanglement or strangulation hazard that may result in injury, damage or death.

- Ensure all cable(s) are routed and secured properly.
- Ensure there are no loops of excess cable extending away from the chair.
- Close supervision and attention is needed when operating the wheelchair near children, pets or people with physical/mental disabilities.



WARNING!

Risk of Injury, Damage or Death

Pinched or severed cable(s) may be a shock or fire hazard and may cause injury, damage or death.

- Ensure all cable(s) are routed and secured properly.
- Inspect cable(s) periodically for proper routing, pinching, chafing or other similar wear.
- Replace any damaged cables immediately.



WARNING!

Risk of Serious Injury

Sharp edges can cause serious injury.

- Be mindful that some parts may have sharp edges.
- Use caution when encountering these sharp edges.



WARNING!

Risk of Serious Injury

Hot surfaces can cause severe burns.

- Be mindful of potential hot surfaces and avoid touching.



WARNING!

Risk of Minor to Serious Injury

Pinch points can cause minor to serious injury.

- Be mindful of potential pinch points and use caution when using this product.

**WARNING!****Risk of Injury or Damage**

Unexpected failure of the device and the wheelchair can occur when the batteries used to power the wheelchair are also used to power other medical devices. To avoid injury or damage:

- DO NOT connect any medical devices such as ventilators, life support machines, etc. directly to the batteries used to power the wheelchair.
- Any medical devices attached to the wheelchair MUST have an auxiliary power source.

**WARNING!****Risk of Injury or Damage**

Grease may leak from the gearbox and cause injury or damage from falling or fire.

- Follow the maintenance instructions in this manual.
- Routinely inspect the gearbox for grease leakage. If the gearbox is leaking grease:
 - Stop use immediately.
 - Keep the product away from sparks, flame, and open heat sources.
 - Contact your provider or Invacare for repair.

**DANGER!****Risk of Death, Serious Injury, or Damage**

Missing attaching hardware could cause instability resulting in death, serious injury or damage.

- Ensure all attaching hardware is present and tightened securely.

10.1.2 Repair and Service Information — Providers and/or Qualified Technicians

**DANGER!****Risk of Injury, Damage or Death**

Improper setup, service, adjustment or programming may cause injury, damage or death.

- Qualified technician MUST setup, service and program the wheelchair.
- DO NOT allow non-qualified individuals to perform any work or adjustments on the wheelchair.
- DO NOT setup or service the wheelchair while occupied except for programming or unless otherwise noted.
- Turn off power BEFORE adjusting or servicing the wheelchair. Note that some safety features will be disabled.
- Ensure all hardware is securely tightened after setup, service or adjustments.
- Warranty is void if non-qualified individuals perform any work on this product.

**Risk of Death, Serious Injury, or Damage**

Corroded electrical components due to water and/or liquid exposure, or incontinent users can result in death, serious injury, or damage.

- Minimize exposure of electrical components to water and/or liquids. Electrical components damaged by corrosion MUST be replaced immediately.
- Wheelchairs that are used by incontinent users and/or are frequently exposed to water/liquids may require replacement of electrical components more frequently.

**WARNING!**

-DO NOT overtighten hardware attaching to the frame. This could cause damage to the frame tubing.

**Risk of Injury, Damage or Death**

Improper installation or service may result in injury, damage or death.

- Transport ready packages are not retrofittable to existing models and are not field serviceable.
- DO NOT overtighten hardware.

10.2 Setup/Delivery Inspection



Setup/delivery inspection should be performed by provider at time of delivery/set up. Initial adjustments should be made to suit your personal body structure needs and preference. Thereafter weekly, monthly and periodic inspections should be performed by user/attendant between the six month service inspections. Refer to *Chapter 9 Maintenance, page 64*.

- Check all parts for shipping damage. In case of damage, DO NOT use.
- Ensure wheelchair rolls straight (no excessive drag or pull to one side).
- Ensure clothing guards are secure.
- Ensure arms are secure but easy to release and adjustment levers engage properly.
- Ensure adjustable height arms operate and lock securely.
- Ensure axle nut or bolt and wheel mounting nuts are secure on drive wheels.
- Ensure caster/anti-tipper wheels are free of debris, and all mounting hardware is secure and not damaged/missing.
- Check that cables are routed and secured properly to

ensure that cables do NOT become entangled and damaged during normal operation of seating system.

- Ensure proper operation of powered functions (Example: drive, seating and legrests).

10.3 Service Inspection



Every six months the wheelchair should be thoroughly inspected and serviced by a qualified technician. Service inspections MUST be performed by a qualified technician.



DANGER!

Risk of Injury, Damage or Death

Overinflation of tires may cause tires to explode.
 -Inflate tire to the proper tire pressure (P.S.I. / kilopascals) listed on the side wall of the tire.
 -Only use wheelchair with tires at proper pressure.
 -The wheels and tires should be checked periodically for cracks and wear and should be replaced if necessary.



WARNING!

Risk of Serious Injury or Damage

Hardware that is loosely secured could cause loss of stability resulting in serious injury or damage.
 -After ANY adjustments, repair or service and before use, make sure that all attaching hardware is tightened securely.

The following are recommended items to inspect during regular service inspections performed by a qualified technician. Actual items to be inspected during the service inspection may vary according to the specific wheelchair.

10.3.1 Six Month Inspection



DANGER!

Risk of Death, Serious Injury, or Damage

Failure to complete the inspection of the critical components listed below could result in death or serious injury.
 -Inspect drive axle nut, locking tab, wheel fasteners or quick release to ensure drive wheel is secure.

- Inspect swing arm to ensure proper operation.
- Ensure adjustable height arms operate and lock securely.
- Ensure arms are secure but easy to release and adjustment levers engage properly.
- Inspect seat positioning strap for any signs of wear. Ensure buckle latches. Verify hardware that attaches strap to frame is secure and undamaged. Replace if necessary.
- Ensure axle nut or bolt and wheel mounting nuts are secure on drive wheels. Torque to 45 ft-lb (61 Nm).
- Inspect tires for flat spots and wear.
- Loosen/tighten caster bolt if wheel wobbles noticeably or

binds to a stop. Torque caster wheel to 25 ft-lb (34 Nm).

- Ensure all caster/wheel/fork/headtube fasteners are secure and not damaged/missing. Torque caster wheel to 25 ft-lb (34 Nm). Refer to the service manual for fork tightening instructions.
- Check center mount front riggings for loose fasteners. Replace /tighten if necessary. Torque to 166 in-lbs (14 ft-lbs, 18 Nm).
- Cables shall be inspected periodically to ensure that they are routed and secured properly. Periodic inspection is recommended as it may reveal loose and/or damaged cables. Re-secure all loose cables and replace by following the recommendations outlined in the LiNX Controls System Service Manual.
- Ensure proper operation of powered functions (drive, seating, legrests, etc.).
- Inspect gearbox coupling.
- Inspect electrical components for signs of corrosion. Replace if corroded or damaged.
- Inspect battery terminals for loose cable connection. Tighten if necessary.
- Ensure swingarm stops are in place and not deteriorated or damaged. Replace if necessary.
- Clean upholstery and armrests.
- Clean dirt and lint from axles.
- Clean dirt and lint from bearings.
- Check that all labels are present and legible. Replace if necessary.
- Ensure clothing guards are secure.
- Ensure upholstery does not have any rips or tears.
- Ensure armrest pad sits flush against arm tube.
- Ensure wheelchair rolls straight (no excessive drag or pull to one side).
- Ensure that the casters are free of debris.
- Inspect all fasteners including the back pan, back cane and angle adjustment fasteners, and the arm support, flip back and height adjustment fasteners. Ensure fasteners are securely tightened. Refer to the seating system service manual for torque specifications and tightening instructions.
- Inspect TRBKTS fasteners and hardware.
- Inspect foam handgrips for damage. If damaged, have

them replaced by a qualified technician.

10.3.2 Replace Every 18 Months

Replace gearbox coupling.

10.4 Removing/Installing the Shrouds



CAUTION!

-Place the wheelchair in a well ventilated area where work can be performed without risking damage to carpeting or floor covering.

10.4.1 Removing/Installing the Rear Shroud Assembly

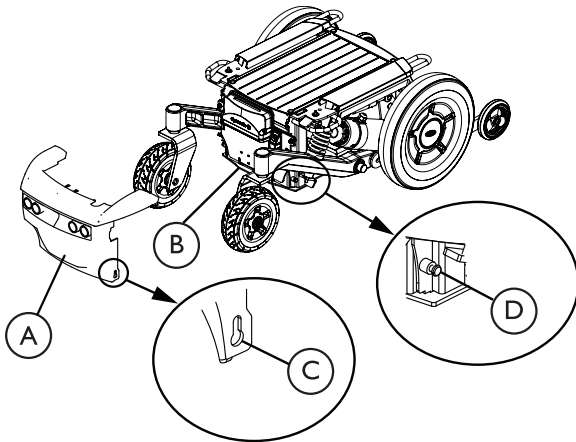

Fig. 10-1 Removing/Installing the Rear Shroud Assembly



Seat assembly not shown for clarity.

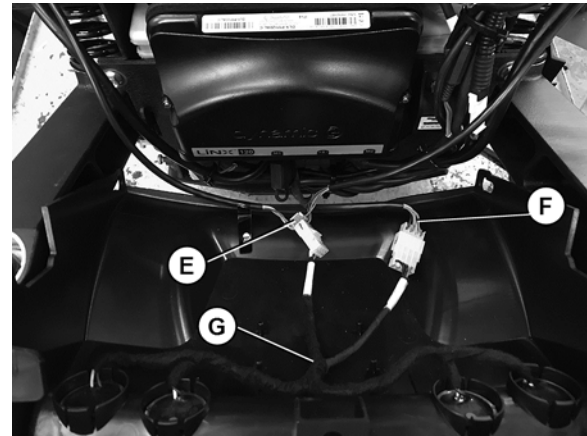

Fig. 10-2 Removing/Installing the Rear Shroud Assembly - Disconnecting the lighting board

Removing the Rear Shroud Assembly

1. Verify the joystick On/Off switch is in the Off position.
2. Pull up to disengage the top of the rear shroud assembly (A) from the battery box (B).
3. Pull up to disengage the keyholes (C) from the battery box pegs (D).
4. Remove the rear shroud assembly from the battery box, one side at a time.

5. If lights are present, disconnect the front lights connector ⑤ and the light power cable connector ⑥ from the rear lighting harness ③ inside of the rear shroud.

Installing the Rear Shroud Assembly

1. If lights are present, connect the front lights connector ⑤ and the light power cable connector ⑥ to the rear lighting harness ③ inside of the rear shroud. Ensure they are connected in the proper location, marked by the labels on each cable.
2. Install the keyhole ④ in the bottom of the rear shroud assembly ① onto the pegs ② on the battery box ③, one side at a time.

3. Rotate the top of the rear shroud assembly forward under bumper screws ④, if present. Route the cables:

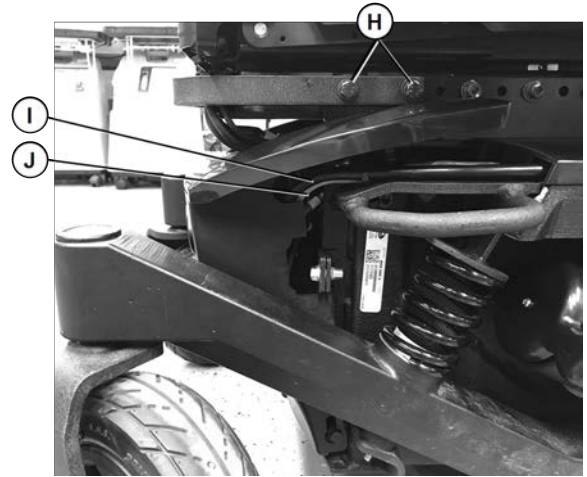

Fig. 10-3 Installing the Rear Shroud Assembly - Routing the lighting and motor cables

- A. Route motor cables ① and light cables ② through the top opening in both sides of the rear shroud.
- B. Group other cables ③ and route through the front right opening in the top shroud.

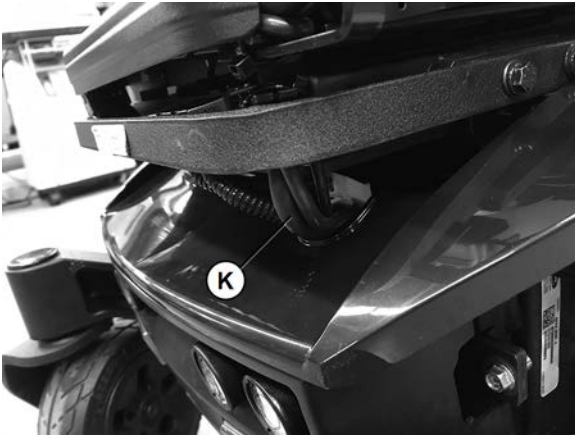
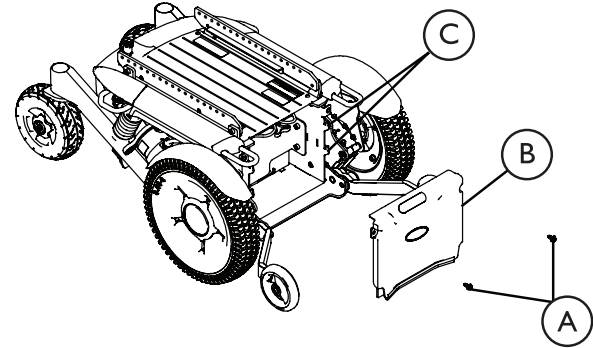



Fig. 10-4 Installing the Rear Shroud Assembly - Routing other cables

4. Push the rear shroud down to engage the rear shroud assembly with the pegs on the battery box.
5. Rotate the top of the rear shroud assembly all the way forward and push down to engage securely with the battery box.

10.4.2 Removing/Installing the Front Shroud Assembly



 Seat assembly not shown for clarity.

Removing the Front Shroud Assembly

1. Verify the joystick On/Off switch is in the Off position.
2. Use a 10mm socket to remove the two (2) bolts **A** securing the front shroud assembly **B** to the front of the battery box.
3. Lift the front shroud assembly up off of the battery box tabs **C** and pull towards the front of the wheelchair to release from the battery box.

Installing the Front Shroud Assembly

1. Install the front shroud assembly ⑥ onto the battery box tabs ③.
2. Use the 10 mm socket to install the two (2) bolts ④ and secure the front shroud to the battery box. Torque to 90 in-lbs (10 Nm).

10.5 Battery Service

10.5.1 General Instructions on Handling the Batteries

- The batteries reach their end of life when the drive range is significantly smaller than usual. Contact your provider or service technician for details.
- Always have your batteries installed by a properly trained mobility device technician or a person with adequate knowledge. They have the necessary training and tools to do the job safely and correctly.

10.5.2 How to Handle Damaged Batteries Correctly



WARNING!

Risk of Injury

Exposure to battery acid may result in injury.

- The use of rubber gloves is recommended when working with batteries.
- DO NOT allow the liquid in the battery to come in contact with skin, clothes or other possessions. It is a form of acid and harmful or damaging burns may result. Remove clothes that have been soiled by acid immediately. Should the liquid touch your skin, wash the area IMMEDIATELY and thoroughly with cool water. In serious cases or if eye contact is made, seek medical attention IMMEDIATELY.
- DO NOT install/reinstall a battery with a cracked or otherwise damaged case.

- Always wear safety goggles and appropriate safety clothing when handling damaged batteries.
- Place damaged batteries in an acid-resistant receptacle immediately after removing them.
- Only ever transport damaged batteries in an appropriate acid-resistant receptacle.
- Wash all objects that have come into contact with acid with lots of water.

Disposing of dead or damaged batteries correctly

Dead or damaged batteries must be disposed of properly. Refer to 10.5.8 *Recycling Batteries*, page 87 for more information.

10.5.3 General Information on Battery Installation



WARNING!

Risk of Injury or Damage

Improper installation of the battery can result in injury or damage.

-Batteries can weigh up to 52 lbs (23.6 kg). ALWAYS use a battery lifting strap when lifting the battery. It is the most reliable method of carrying a battery and preventing serious injury.



WARNING!

Risk of Injury or Damage

Improper lifting technique may cause injury or damage.

-Use proper lifting techniques, assistance and gear such as straps when available when lifting heavy loads.



WARNING!

Risk of Injury

Exposure to battery acid may result in injury.

-The use of rubber gloves is recommended when working with batteries.

-DO NOT allow the liquid in the battery to come in contact with skin, clothes or other possessions. It is a form of acid and harmful or damaging burns may result. Remove clothes that have been soiled by acid immediately. Should the liquid touch your skin, wash the area IMMEDIATELY and thoroughly with cool water. In serious cases or if eye contact is made, seek medical attention IMMEDIATELY.

-DO NOT install/reinstall a battery with a cracked or otherwise damaged case.



Invacare strongly recommends battery installation and replacement be performed by a qualified technician. Read the installation instructions noted on the battery and in the manual.

Ensure there is no battery acid in the bottom or around the battery box or on the sides of the battery (ies). Neutralize battery acid with baking soda if found. Clean battery tray and batteries prior to installation. Use battery lifting strap when available.

Keep batteries in an upright position and avoid tipping. Use only deep cycle gel cell battery.

Use box wrench when tightening clamps. Do Not wiggle the battery terminals/posts when tightening.

10.5.4 Removing the Batteries from the Wheelchair



CAUTION!

Risk of Damage

Cleaning or maintenance may cause damage to carpeting or flooring.

-Place the wheelchair in a well ventilated area where cleaning or maintenance can be performed without risk of damage to carpeting or flooring.



- 10 mm Hex Socket

1. Place the wheelchair in a well ventilated area.
2. Verify the battery isolation switch is in the Off position. Refer to *7.3 Using the Battery Isolation Switch, page 48* for more information.
3. Remove the rear shroud assembly. Refer to *10.4.1 Removing/Installing the Rear Shroud Assembly, page 75*.

4. Disconnect the left motor cable © from the power module Ⓟ.



Fig. 10-5 Disconnecting the motor cable

5. Using the 10 mm socket, remove the two bolts Ⓜ securing the battery door assembly Ⓝ to the rear of the battery box ©.

-  The power module **(P)** and GTRAC module **(W)** will remain attached to the battery door assembly during this procedure.

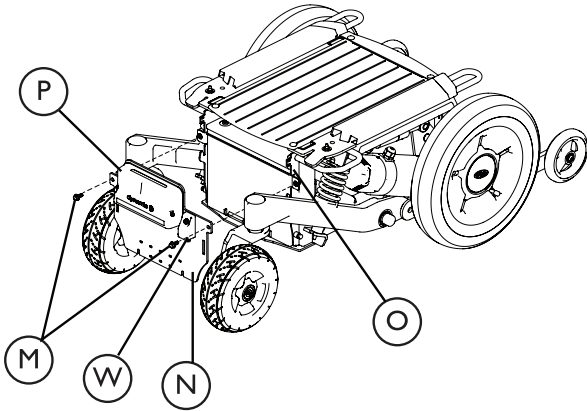

6. Lift up and pull back to remove the battery door assembly from the battery box.

7. Swing battery door assembly **(N)** with power module **(P)** and attached cables over the right rear swingarm and gently place on the ground.

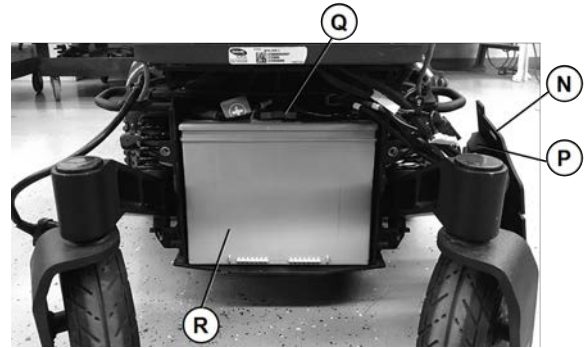

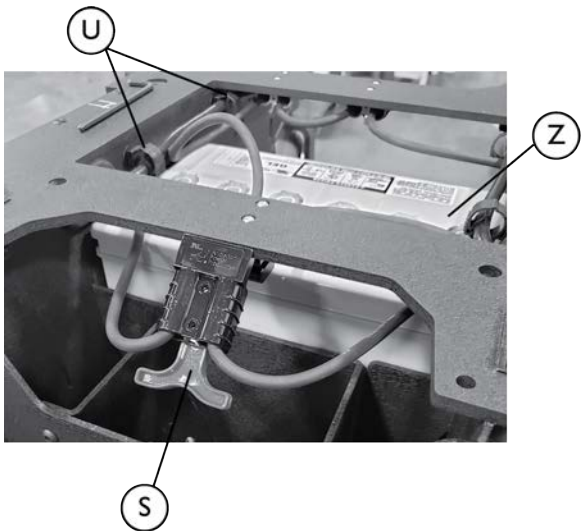

Fig. 10-6 Disconnect the Rear Battery

8. Disconnect the rear battery harness (red handle) **(C)**.
9. Slide the rear battery **(R)** out of the battery box.
-  Ensure battery cable covers (not shown) do not snag on cables attached to the power module.
10. Remove the front shroud assembly. Refer to *10.4.2 Removing/Installing the Front Shroud Assembly, page 77*.
11. Disconnect the front battery harness **(S)** (red handle).
12. Slide the front battery **(Z)** out of the rear of the battery box.

- ⓘ Ensure battery cable covers (not shown) do not snag on cable clips **U** inside of the battery box.



10.5.5 Installing Batteries into the Wheelchair



WARNING!

Risk of Serious Injury

Improperly installed battery tray can cause instability resulting in serious injury.

- Ensure batteries and battery tray are installed properly to maintain stability.

- ⓘ Batteries **MUST** be installed in the orientation specified for proper connection.

1. Slide the front battery **Z** into the rear of the battery box with the connector oriented towards the front of the wheelchair.

- ⓘ Ensure battery cable covers (not shown) do not snag on cable clips **U** inside of the battery box.

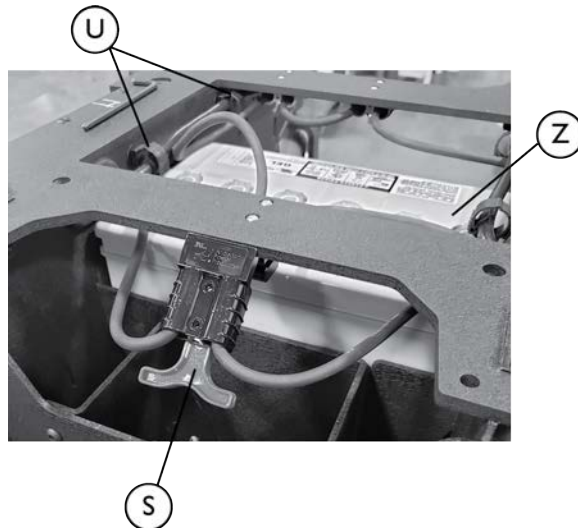

2. Connect the front battery harness **S** (red handle).



- 10 mm Hex Socket with Torque Wrench

3. Install the front shroud. Refer to 10.4.2 *Removing/Installing the Front Shroud Assembly, page 77.*
4. Slide the rear battery **®** into the battery box with the connector towards the rear of the wheelchair.

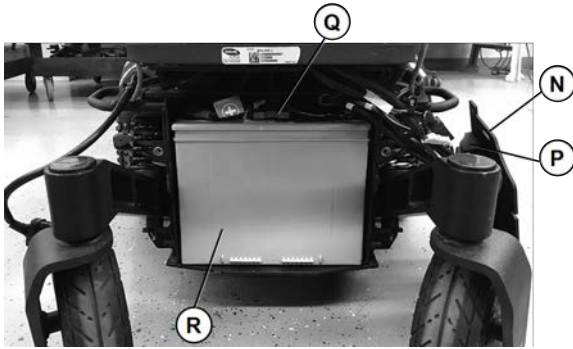

Fig. 10-7 Connect the Rear Battery

5. Connect the rear battery harness (red handle) **©**.
6. Lift the battery door assembly **®** with power module **®** and attached cables over the right rear swingarm and position it at the rear of the battery box.

7. Lift up and install the battery door assembly onto the battery box.



Ensure the hooks on the battery box are seated properly in the slots on the battery box door.

The power module **®** and GTRAC module **®** will remain attached to the battery door assembly during this procedure.

8. Install the two bolts **®** to secure the battery door assembly **®** to the rear of the battery box **©**. Torque to 90 in-lbs (7.5 ft-lbs, 10 Nm).

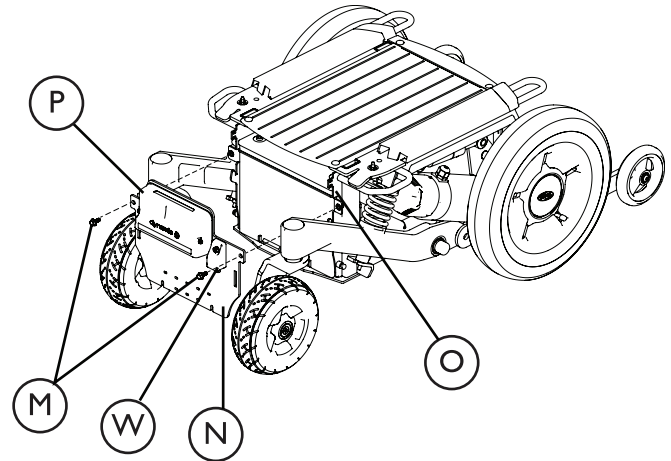

9. Connect the left motor cables ⑥ to the power module ⑦ as noted during the battery removal procedure.



Fig. 10-8 Connecting the motor cable

10. If tie-wraps were removed, tie-wrap the cables as noted during the battery removal procedure.

11. Install the rear shroud. Refer to *10.4.1 Removing/Installing the Rear Shroud Assembly*, page 75.
12. Switch the battery isolation switch to the ON position. Refer to *7.3 Using the Battery Isolation Switch*, page 48 .
13. If installing NEW batteries—The Battery Synchronization Procedure MUST be performed within 24 hours of powering on the wheelchair. Otherwise the battery gauge will not display accurate battery charge levels. The Battery Synchronization Procedure can be found in the LiNX service manual and must be performed by a provider or qualified technician.

10.5.6 Replacing Battery Cables



7/16 inch (6 pt) Box Torque Wrench

**WARNING!****Risk of Death or Serious Injury**

Failure to observe these warnings can cause an electrical short resulting in death, serious injury, or damage to the electrical system.



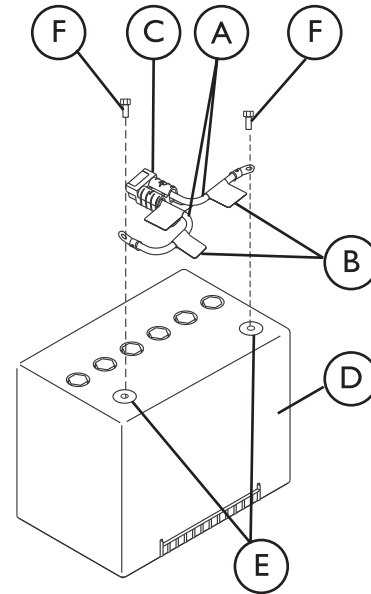









- The POSITIVE (+) battery cable MUST connect to the POSITIVE (+) battery terminal.
- The NEGATIVE (-) battery cable MUST connect to the NEGATIVE (-) battery terminal.
- NEVER allow any of your tools and/or battery cables to contact BOTH battery terminals at the same time.
- An electrical short may occur and serious injury or damage may occur.
- Install protective caps on positive and negative battery terminals.
- Replace cables immediately if cable insulation becomes damaged.



Battery cable **A** polarity — POSITIVE (+) or NEGATIVE (-) — is determined by the label **B** and terminal cover (not shown) color.

Battery cable polarity is NOT determined by the markings on the battery connector **C**.

1. Remove the batteries **D** from the wheelchair.
Refer to *10.5.4 Removing the Batteries from the Wheelchair, page 80.*

2. Note the orientation of the battery cables  on the batteries .
3. Slide the battery terminal covers (not shown) back on the battery cables  to expose the battery terminals .
4. Remove the screws  that secure the battery cables  to the battery terminals .
5. Discard the existing battery  per local laws and regulations. Refer to *11.2 Disposal, page 88*.
6. Orient the battery cables  as noted in STEP 2.
7. Secure the NEGATIVE (-) battery cable to the NEGATIVE (-) battery terminal with existing mounting screw . Torque to 55 in-lbs (6 Nm).
8. Secure the POSITIVE (+) battery cable to the POSITIVE (+) battery terminal with existing mounting screw . Torque to 55 in-lbs (6 Nm).
9. Position each battery terminal cover (not shown) over top of each battery terminal .
10. Install batteries  into wheelchair. Refer to *10.5.5 Installing Batteries into the Wheelchair, page 82*

10.5.7 Cleaning Battery Terminals



WARNING! **Risk of Injury**

Exposure to battery acid may result in injury.

- The use of rubber gloves is recommended when working with batteries.
- DO NOT allow the liquid in the battery to come in contact with skin, clothes or other possessions. It is a form of acid and harmful or damaging burns may result. Should the liquid touch your skin, wash the area IMMEDIATELY and thoroughly with cool water. In serious cases or if eye contact is made, seek medical attention IMMEDIATELY.
- DO NOT install/reinstall a battery with a cracked or otherwise damaged case.

1. Examine battery terminals for corrosion.
2. Verify the plastic caps are in place over battery cell holes.
3. Clean terminals by using a battery cleaning tool, wire brush, or medium grade sand paper.

 Upon completion, areas should be shiny, not dull.
4. Carefully dust off all metal particles.

10.5.8 Recycling Batteries



Lead acid batteries are almost entirely recyclable. Discarding these batteries in the trash is considered “improper disposal” and is illegal in most states. Old, used batteries are “hazardous material” and **MUST** be recycled through an approved agency. Contact your provider or Invacare on proper disposal and recycling of your batteries.

11 After Use

11.1 Reuse

The product is suitable for reuse. To recondition the product for a new user, carry out the following actions:

- Clean the product. Refer to *Chapter 9 Maintenance, page 64*.
- Inspection according to service plan. Consult service instructions, available from Invacare.
- Adaptation to the user. Refer to *Chapter 5 Setup, page 33*.

11.2 Disposal



- The equipment wrapping is potentially recyclable.
- The metal parts are used for scrap metal recycling.
- The plastic parts are used for plastic recycling.

- Electric components and printed circuit boards are disposed of as electronic scrap.
- Old, used or damaged batteries are hazardous material and **MUST** be recycled through an approved agency. Discarding these batteries in the trash is considered improper disposal and is unlawful in many locations. Contact your provider or Invacare for proper disposal and recycling of your batteries.
- Disposal must be carried out in accordance with the respective national legal provisions.
- Ask your city or district council for details of the local waste management companies.

12 Troubleshooting

12.1 Driving Performance

	Solutions		
	Checkcasters for loose or overtightened stem nuts/bolts, bearings or signs of wear.	Check for uneven tire wear, bent fork/frame or loose hardware.	If pneumatic, check tires for correct and equal pressure.
Wheelchair Veers Left or Right	X	X	X
Sluggish Turn or Performance	X		X
Casters Flutter	X	X	X
Squeaks and Rattles		X	
Looseness in Wheelchair		X	X
Wheelchair 3 Wheels		X	X

12.2 Control System



For additional troubleshooting information and explanation of error codes, refer to the individual remote (joystick) manual supplied with each wheelchair.

SYMPTOM	PROBABLE CAUSE	SOLUTIONS
Batteries draw excessive current when charging.	Battery failure. Electrical malfunction.	Have batteries checked for shorted cell. Replace if necessary. Contact Provider/Invacare for service.

SYMPTOM	PROBABLE CAUSE	SOLUTIONS
Battery indicator flashes the charge level is low - immediately after recharge.	Battery failure. Malfunctioning battery charger. Electrical malfunction.	Check batteries for shorted cell. Replace if necessary. Contact Provider/Invacare for Service. Contact Provider/Invacare for Service.
Battery indicator flashes the charge level is low - too soon after being recharged.	Batteries not charged. Weak batteries.	Have charger checked. Replace batteries if necessary. Refer to <i>10.5.6 Replacing Battery Cables, page 84.</i>
Motor “chatters” or runs irregular.	Motor/gearbox malfunction.	Stop use of Wheelchair. Contact Provider/Invacare for Service.
Joystick erratic or does not respond as desired.	Damaged motor coupling. Electrical malfunction. Controller programmed improperly.	Contact Provider/Invacare for Service. Contact Provider/Invacare for Service. Contact Provider/Invacare to have controller reprogrammed.
Wheelchair does not respond to commands.	Battery isolation switch is activated. Electrical malfunction.	Check that battery isolation switch is deactivated (in the Power On position). Refer to <i>7.3 Using the Battery Isolation Switch, page 48.</i> Contact Provider/Invacare for Service.
Power indicator off - even after recharging.	Battery isolation switch is activated.	Check that battery isolation switch is deactivated (in the Power On position). Refer to <i>Using the Battery Isolation Switch, page 1.</i> Have terminals cleaned.

SYMPTOM	PROBABLE CAUSE	SOLUTIONS
	Poor battery terminal connection.	

12.2.1 Battery and Charger Tips

The following “Do’s” and “Don’ts” are provided for your convenience and safety.

DON'T	DO
Don't perform any installation or maintenance without first reading this manual.	Read and understand this manual and any service information that accompanies a battery and charger before operating the wheelchair.
Don't perform installation or maintenance of batteries in an area that could be damaged by battery spills.	Move the wheelchair to a work area before cleaning terminals, or opening battery box.
Don't make it a habit to discharge batteries to the lowest level.	Recharge as frequently as possible to maintain a high charge level and extend battery life.
Don't use randomly chosen batteries or chargers.	Follow recommendations in this manual when selecting a battery or charger.
Don't put new batteries into service before charging.	Fully charge a new battery before using.
Don't tip or tilt batteries.	Use a carrying strap to remove, move or install a battery.
Don't tap on clamps and terminals with tools.	Push battery clamps on the terminals. Spread clamps wider if necessary.
Don't mismatch your battery and chargers.	Use only a gel charger for a gel battery.

13 Technical Data

13.1 Technical Specifications

The technical information provided hereafter applies to a standard configuration or represents maximum achievable values. These can change if accessories are added. The precise changes to these values are detailed in the sections for the respective accessories.



Note that in some cases the measured values may vary up to $\pm .50$ inches (± 10 mm).

Permissible operating and storage conditions	
Temperature range for operation according to ISO 7176-9:	<ul style="list-style-type: none"> -13 — 122 °F (-25 — +50 °C)
Recommended storage temperature:	<ul style="list-style-type: none"> 59 °F (+15 °C)
Temperature range for storage according to ISO 7176-9:	<ul style="list-style-type: none"> -13 — 149°F (-25 — 65 °C) with batteries -40 — 149 °F (-40 — +65 °C) without batteries
Charging device	
Output current	<ul style="list-style-type: none"> 8 A nominal (110 V)
Output voltage	<ul style="list-style-type: none"> 24 V nominal
Base Configuration	Front Wheel Drive
Motors	<ul style="list-style-type: none"> Durawatt™ 4-pole SSD Power: 24V DC/324 W at 13.5 Amps

	<ul style="list-style-type: none"> • Voltage: 24 V nominal
Motor Gearbox Sound Level	<ul style="list-style-type: none"> • 64dBa
Batteries	<ul style="list-style-type: none"> • Number: 2 • Type: GP24 • Chemistry: Sealed VRLA Gel • Operating Voltage: 24V nominal (2 x 12 V) • GP24 Battery weight: approximately 51.5 lbs (23.4 kg) per battery • GP24 Amp-Hour Rating: 73.6 Ah (C20) (63 Ah (C5)) • Circuit breaker: 63 Amps, 5 KA rated break capacity
Degree of protection ¹	<ul style="list-style-type: none"> • Power Wheelchair Base — IPX4 • Charger — IPX1
Drive wheels	<ul style="list-style-type: none"> • Black with rim inserts, 14 x 3” • Black tires with gel foam inserts or pneumatic tires <p> The recommended maximum tire pressure in bar or kpa is marked on the side wall of the tire or the rim. If more than one value is listed, the lower one in the corresponding units applies. (Tolerance = -0.3 bar, 1 bar = 100 kpa)</p>

Forks	Single sided forks
Casters	<ul style="list-style-type: none"> • Black, 8 x 2" • Puncture proof

Driving characteristics	
Maximum Speed	<ul style="list-style-type: none"> • 5.8 mph (9.3 km/h) • 7.5 mph (12 km/h)
Minimum braking distance	<ul style="list-style-type: none"> • 5.8 mph (9.3 km/h): 69.6 in (1767 mm) • 7.5 mph (12 km/h): 112.9 in (2867 mm)
Rated slope ²	<ul style="list-style-type: none"> • 9° (15.8 %) according to manufacturer's specifications with 300 lb (136 kg) payload
Maximum climbable obstacle height	<ul style="list-style-type: none"> • 3.25 in (83 mm) Forward • 2.5 in (64 mm) Reverse
Turning diameter	<ul style="list-style-type: none"> • 53.5 in (1360 mm)
Pivot width	<ul style="list-style-type: none"> • 53.5 in (1360 mm)
Drive range in accordance with ISO 7176-4 ³	<ul style="list-style-type: none"> • 5.8 mph (9.3 km/h): 20.4 mi (32.8 km)₄ • 7.5 mph (12 km/h): 12.7 mi (20.4 km)₄

Dimensions according to ISO 7176–15	
Total length (including center-mounted front rigging)	<ul style="list-style-type: none"> • 51.4 in (1305 mm) at 0°
Ground clearance	<ul style="list-style-type: none"> • > 3.15 in (80 mm) • 10
Horizontal location of axle ⁷	<ul style="list-style-type: none"> • 16.9–17.3 in (430 – 440 mm)

Weight⁸	
Total mass	379.2–434.3 lb (172–197 kg)

**WARNING!****Risk of Death or Serious Injury**

Exceeding the weight capacity of the wheelchair/seating system could cause instability resulting in death or serious injury.

-DO NOT exceed the weight capacity.

Weight Capacity/Payload	
Maximum weight capacity/payload ⁹	<ul style="list-style-type: none"> • Captain's Seat —up to 300 lbs (136 kg) • Non-Elevate Ultra Low Maxx Seat —up to 300 lbs (136 kg) • Elevate Ultra Low Maxx Seat —up to 250 lbs (113 kg)

Weight Capacity/Payload	
	 Weight limitation is total weight (user weight plus any additional items that the user may require [back pack, ventilator, etc.]). Example: If weight limitation of the wheelchair is 300 lbs and additional items equal 25 lbs, subtract 25 lbs from 300 lbs. This means the maximum weight limitation of the user is 275 lbs.

Axle loads	
Maximum drive axle load	<ul style="list-style-type: none"> • 571 lbs (259 kg)
Maximum rear axle load	<ul style="list-style-type: none"> • 228 lbs (103 kg)

Other Specifications	
Lateral dynamic stability while turning in a circle:	1.36 m
Lateral dynamic stability while turning suddenly:	Yes

- 1 IPX4 classification means that the electrical system is protected against spray water.
IPX1 classification means that the charger is protected against vertically falling drops of water.
- 2 Static stability downhill, uphill, and sideways according to ISO 7176-1 = 9° (15.8 %)
Dynamic stability uphill according to ISO 7176-2 = 9° (15.8 %)

- 3 Note: The drive range of a mobility device is strongly influenced by external factors, such as the speed setting of the wheelchair, the charging state of the batteries, surrounding temperature, local topography, road surface characteristics, tire pressure, weight of user, drive style and use of batteries for lighting, servos etc.

The specified values are theoretical maximum achievable values measured according to ISO 7176-4.

- 4 Measured with solid tires. Pneumatic tires can increase the maximum total width.
- 5 Measured without seat cushion
- 7 Horizontal distance of wheel axle from intersection of loaded seat and backrest reference planes
- 8 The actual curb weight depends on the options and accessories your mobility device has been supplied with. Every Invacare mobility device is weighed when leaving the factory. Refer to the invoice for the curb weight (including batteries) measured.
- 9 If two values are possible the lowest always applies.
- 10 Ground clearance measured under the battery box with no weight on the wheelchair.

13.2 ISO 7176-15 Annex A

13.2.1 AVIVA FX with LiNX and Captain's Seat

Information Disclosure in Manufacturer's Specification Sheets

Manufacturer: Invacare Corporation

Address: 1200 Taylor Street, Elyria, OH 44035

Maximum occupant mass: 300 lb (136 kg)

Disclosure Information (ISO)	AVIVA FX with Captain's Seat	
	Minimum	Maximum
Overall length with legrest	43.7 in (1110 mm)	N/A
Overall width	29.1 in (740 mm)	35.0 in (890 mm)
Folded length	42.5 in (1080 mm)	N/A

Disclosure Information (ISO)	AVIVA FX with Captain's Seat	
	Minimum	Maximum
Folded width	24.4 in (620 mm)	N/A
Folded height	33.5 in (850 mm)	N/A
Total mass	381.4 lb (173 kg)	N/A
Mass of heaviest part	363.8 lb (165 kg)	N/A
Static stability downhill	10°	24°
Static stability uphill	N/A	30°
Static stability sideways	19°	26°
Energy consumption	20.4 mi (32.9 km)	12.7 mi (20.4 km)
Dynamic stability uphill	N/A	10°
Obstacle climbing	3.0 in (75 mm)	4.1 in (105 mm)
Maximum speed forward	5.8 mph (9.3 km/h)	7.5 mph (12 km/h)
Minimum braking distance from max speed	69.6 in (1767 mm)	112.9 in (2867 mm)
Seat plane angle	7°	N/A
Effective seat depth	17.7 in (450 mm)	N/A
Effective seat width	21.7 in (550 mm)	26.4 in (670 mm)
Seat surface height at front edge	22.4 in (570 mm)	24.4 in (620 mm)
Backrest angle	0°	26°
Backrest height	17.7 in (450 mm)	N/A

Disclosure Information (ISO)	AVIVA FX with Captain's Seat	
	Minimum	Maximum
Footrest to seat distance	15.7 in (400 mm)	20.9 in (530 mm)
Leg to seat surface angle	77°	N/A
Armrest to seat distance	6.7 in (170 mm)	10.2 in (260 mm)
Front location of armrest structure	0.4 in (10 mm)	N/A
Handrim diameter	N/A**	N/A**
Horizontal location of axle	11.8 in (300 mm)	N/A
Minimum turning radius	26.0 in (660 mm)	N/A
The wheelchair conforms to the following standards:		
a) requirements and test methods for static, impact and fatigue strengths (ISO 7176–8)	YES	
b) power and control systems for electric wheelchairs — requirements and test methods (ISO 7176–14)	YES	
c) climatic test in accordance with ISO 7176–9	YES	
d) requirements for resistance to ignition in accordance with ISO 7176–16	YES	



The requirements in this annex which apply are only those that are relevant to the specific wheelchair being disclosed. For example, parts of the table apply only to powered wheelchairs and therefore would not apply to manual wheelchairs.

* Folded length, Folded width and Folded height are only required for wheelchairs which have folding frames.

** Handrim diameter is only required for wheelchairs with handrims as an option.

13.2.2 AVIVA FX with LiNX and Ultra Low Maxx Seat Information Disclosure in Manufacturer's Specification Sheets

Manufacturer: Invacare Corporation

Address: 1200 Taylor Street, Elyria, OH 44035

Maximum occupant mass:

- Non-Elevate—300 lb (136 kg)
- Elevate—250 lb (113 kg)

Disclosure Information (ISO)	AVIVA FX with Ultra Low Maxx Seat	
	Minimum	Maximum
Overall length with legrest	49.2 in (1250 mm)	51.4 in (1305 mm)
Overall width	29.1 in (740 mm)	35.0 in (890 mm)
Folded length	N/A*	N/A*
Folded width	N/A*	N/A*
Folded height	N/A*	N/A*
Total mass	379.2 lb (172 kg)	434.3 lb (197 kg)
Mass of heaviest part	370.4 lb (168 kg)	414.5 lb (188 kg)
Static stability downhill	9.3°	29°
Static stability uphill	15°	30°
Static stability sideways	9.3°	21°
Energy consumption	20.4 mi (32.9 km)	12.7 mi (20.4 km)

Disclosure Information (ISO)	AVIVA FX with Ultra Low Maxx Seat	
	Minimum	Maximum
Dynamic stability uphill	9°	9°
Obstacle climbing	1 in (25 mm)	3.3 in (83 mm)
Maximum speed forward	5.8 mph (9.3 km/h)	7.5 mph (12 km/h)
Minimum braking distance from max speed	69.6 in (1767 mm)	112.9 in (2867 mm)
Seat plane angle	-6°	54°
Effective seat depth	15.9 in (405 mm)	23 in (585 mm)
Effective seat width	15.9 in (405 mm)	22 in (559 mm)
Seat surface height at front edge	16.34 in (415 mm)	22 in (560 mm)
Backrest angle	82°	168°
Backrest height	18 in (457 mm)	27 in (686 mm)
Footrest to seat distance	13.4 in (340 mm)	16.1 in (410 mm)
Leg to seat surface angle	97°	-7°
Armrest to seat distance	9.1 in (230 mm)	18.7 in (476 mm)
Front location of armrest structure	10 in (254 mm)	23.2 in (590 mm)
Handrim diameter	N/A**	N/A**
Horizontal location of axle	16.9 in (430 mm)	17.3 in (440 mm)
Minimum turning radius	26.8 in (680 mm)	26.8 (680 mm)
The wheelchair conforms to the following standards:		

Disclosure Information (ISO)	AVIVA FX with Ultra Low Maxx Seat	
	Minimum	Maximum
a) requirements and test methods for static, impact and fatigue strengths (ISO 7176–8)	YES	
b) power and control systems for electric wheelchairs — requirements and test methods (ISO 7176–14)	YES	
c) climatic test in accordance with ISO 7176–9	YES	
d) requirements for resistance to ignition in accordance with ISO 7176–16	YES	



The requirements in this annex which apply are only those that are relevant to the specific wheelchair being disclosed. For example, parts of the table apply only to powered wheelchairs and therefore would not apply to manual wheelchairs.

* Folded length, Folded width and Folded height are only required for wheelchairs which have folding frames.

** Handrim diameter is only required for wheelchairs with handrims as an option.

14 Warranty

14.1 Limited Warranty—US

Except as otherwise set forth below, Invacare warrants that the following components of the mobility device (“product”) will be free from defects in materials and workmanship for a period of one (1) year from the date Invacare ships the product to the original purchaser or provider: base frame, electronics and electrical components (excluding batteries), motors, powered seating actuators, gearboxes, bearings and bushings, seat frame, fixed seat post, upholstered materials, padded materials, casters, tires, and tubes (excluding normal wear and tear).

Invacare warrants all product batteries will be free from defects in materials and workmanship for a period of six (6) months from the date Invacare ships the product to the original purchaser or provider. The warranties described above are referred to as the “Warranty”. A copy of the original product invoice is required for coverage under the Warranty.

14.2 Limited Warranty—Canada

Except as otherwise set forth below, Invacare warrants the base frame of the mobility device (“product”) will be free from defects in materials and workmanship for a period of five (5) years from the date Invacare ships the product to the original purchaser or provider. Invacare warrants that the seat frame and fixed seat post will be free from defects in materials and

workmanship for a period of three (3) years from the date Invacare ships the product to the original purchaser or provider. Invacare warrants that the following components of the product will be free from defects in materials and workmanship for a period of two (2) years from the date Invacare ships the product to the original purchaser or provider: electronics and electrical components (excluding batteries), motors, powered seating actuators, gearboxes. Invacare warrants that the following components of the product will be free from defects in materials and workmanship for a period of one (1) year from the date Invacare ships the product to the original purchaser or provider: bearings and bushings, upholstered materials (excluding normal wear and tear), padded materials (excluding normal wear and tear), brake pads (excluding normal wear and tear), casters (excluding normal wear and tear), tires and tubes (excluding normal wear and tear). Invacare warrants all product batteries will be free from defects in materials and workmanship for a period of six (6) months from the date Invacare ships the product to the original purchaser or provider. The warranties described above are referred to as the “Warranty”. A copy of the original product invoice is required for coverage under the Warranty.

14.3 Repair or Replacement

Invacare's sole obligation and the original purchaser's exclusive remedy under the Warranty is limited to Invacare's repair and/or replacement, at Invacare's option, of defective

components and batteries covered by the Warranty. Such repair or replacement does not include any labor or shipping charges incurred by Invacare in the replacement and/or repair of any such component or battery. For Warranty service, please contact the provider from whom you purchased your product. In the event you do not receive satisfactory Warranty service, please write directly to Invacare at the address on the bottom of the back cover. Provide provider's name address, date of purchase, indicate nature of the defect and, if the product is serialized, indicate the serial number. Do not return products to Invacare without Invacare's prior written authorization.

14.4 Limitations and Exclusions

The Warranty is extended only to the original purchaser who purchases the product new and unused from Invacare or a provider. The Warranty is not extended to any other person or entity and is not transferable or assignable to any subsequent purchaser or owner. Coverage under the Warranty will end upon any such subsequent sale or other transfer of title to any other person.

The Warranty does not apply to serial numbered products if the serial number has been removed or defaced, products subject to neglect, abuse, accident, improper operation, maintenance or storage, commercial or fleet use, products modified without Invacare's express written authorization (including, but not limited to, modification through the use of unauthorized parts or attachments), products damaged by reason of repairs made to any component without Invacare's express written authorization, or to a product damaged by circumstances beyond Invacare's control, and such evaluation will be solely determined by Invacare.

The Warranty does not apply to problems arising from normal wear and tear or failure to adhere to the product instructions. A change in operating noise, particularly relative to motors and gearboxes does not constitute a failure or defect and will not be repaired or replaced as all products are expected to exhibit changes in operating noise due to aging.

14.5 Disclaimers

The Warranty may not be modified or waived in any manner whatsoever without Invacare's express written authorization. THE WARRANTY IS EXCLUSIVE AND IN LIEU OF ANY OTHER WARRANTIES, WHETHER EXPRESS OR IMPLIED, STATUTORY OR OTHERWISE, INCLUDING WITHOUT LIMITATION, THE IMPLIED WARRANTIES OF MERCHANTABILITY AND FITNESS FOR A PARTICULAR PURPOSE.

EXCEPT AND TO THE EXTENT AS MAY BE PROHIBITED BY STATE OR PROVINCIAL LAW, IN NO EVENT SHALL INVACARE BE LIABLE FOR ANY DIRECT, INDIRECT, SPECIAL, INCIDENTAL OR CONSEQUENTIAL DAMAGES RESULTING FROM OR ARISING OUT OF OR RELATED TO A DEFECT IN ANY PRODUCT, OR INVACARE'S PERFORMANCE OR FAILURE TO PERFORM ANY OF ITS OBLIGATIONS UNDER THIS WARRANTY, WHETHER OR NOT INVACARE HAS BEEN ADVISED, KNEW OR SHOULD HAVE KNOWN OF THE POSSIBILITY OF SUCH DAMAGES, INCLUDING, BUT NOT LIMITED TO, LOST PROFITS.

Invacare Corporation

USA One Invacare Way, Elyria, OH 44074, USA • 800-333-6900 • www.invacare.com

Canada 570 Matheson Blvd E Unit 8, Mississauga, Ontario, L4Z 4G4 Canada • 800-668-5324 • www.invacare.ca

Manufacturer



Invacare Corporation • One Invacare Way • Elyria, OH 44074, USA

60101916-A 2020-02-27



Making Life's Experiences Possible®



Yes, you can.®