

AD 624053

AD

REPORT R-1777

COMPUTER, GUN DIRECTION, M18 (FADAC)
APPLICABILITY IN DEFENSE COMMUNICATION SATELLITE
ANTENNA POSITIONER SYSTEM

CLEARINGHOUSE FOR FEDERAL SCIENTIFIC AND TECHNICAL INFORMATION			
Hardcopy	Microfiche		
\$ 3.00	\$ 0.50	56 pp	2
ARCHIVE COPY			

by
HELEN SMOLEN

Code 1

AMCMS Code 5331.12.918
DA Project No. 1R322101D253

October 1965

**UNITED STATES ARMY
FRANKFORD ARSENAL
PHILADELPHIA, PA.**



REPORT R-1777

**COMPUTER, GUN DIRECTION, M18 (FADAC)
APPLICABILITY IN DEFENSE COMMUNICATION SATELLITE
ANTENNA POSITIONER SYSTEM**

by

HELEN SMOLEN

**AMCMS Code 5331.12.918
DA Project No. 1R322101D253**

**Fire Control Engineering Directorate
FRANKFORD ARSENAL
Philadelphia, Pa. 19137**

October 1965

FOREWORD

The study described in this report was performed by the U. S. Army, Frankford Arsenal, Philadelphia, Penna. The work was accomplished under DA Project No. 1R322101D253. Mr. A. Chalfin, of the Diagnostic and Direction Systems Engineering Branch, Fire Direction and Diagnostic Equipment Division (FDDE) was the Frankford Arsenal Project Director.

The study was performed from December 1964 to July 1965 by H. Smolen of the Computer Programming and Analysis Branch, FDDE Division.

The technical assistance of Mr. J. Junier is gratefully acknowledged.

ABSTRACT

The study described in this report was undertaken at the request of the U. S. Army Satellite Communications Agency, Ft. Monmouth, N. J., to determine the suitability of Computer, Gun Direction, M18 (FADAC), as the control unit in an Antenna Position Programmer System designed to acquire and track earth satellites.

Results of the study show that FADAC has the capability of performing the required functions, can interface with the remainder of the system, and, at operator's option, either output control data to the antenna positioner within the real time specified, or generate a punched paper tape.

TABLE OF CONTENTS

	<u>Page</u>
FOREWORD	ii
ABSTRACT	iii
INTRODUCTION	1
DESCRIPTION OF FADAC	2
General	2
Input/Output	2
GENERAL PROGRAM DESCRIPTION	4
DETAILED DESCRIPTION OF REAL TIME MODE	9
Hardware Considerations	9
Output Routine	12
Output Codes	12
Timing Estimate	14
DETAILED DESCRIPTION OF PAPER TAPE GENERATOR MODE	16
Hardware Considerations	16
Output Codes	16
Special Features of the Mode II Program	18
Tape Considerations	18
CONCLUSIONS	21
RECOMMENDATIONS	21

TABLE OF CONTENTS (Cont'd)

	<u>Page</u>
APPENDIX A - Conventions Used in Coding.	23
APPENDIX B - Program Listing - Real Time Mode	25
APPENDIX C - FADAC Mnemonics	42
APPENDIX D - Definition of Symbols Other Than Inputs, Used in General Computation Routine	46
DISTRIBUTION	48

INTRODUCTION

At the request of the U. S. Army Satellite Communications Agency, Ft. Monmouth, N. J., a study was undertaken to determine the suitability of Computer, Gun Direction, M18 (FADAC) as the control unit in an Antenna Position Programmer System designed to acquire and track earth satellites. "Suitability" was defined as the ability of FADAC to operate in each of two modes, as follows:

1. MODE I - Real Time Mode

Given input parameters which define start time, the location of the ground link control station and the motion of the satellite, compute required azimuth (AZ) and elevation (EL) angles at which the antenna must be fixed to initiate tracking; accept a time signal from an external source and output the computed parameters in electrical pulse form to the next stage of the system. Update time by 10 seconds, recompute AZ and EL, and compute the change in AZ and EL as a function of change in time (ΔAZ and ΔEL), and rate of change per 1/10 second ($\Delta AZ/100$ and $\Delta EL/100$). On receipt of the next time signal, output the computed parameters in a fixed order. Repeat the compute and output operations at 10-second real-time intervals over a 24-hour period, a total of 8640 times.

2. MODE II - Paper Tape Generator Mode

Given input parameters which define start time, the location of the tracking station and the motion of the satellite, compute the six parameters described in (1) above. Output a properly formatted Time Identification Line, followed by the six time-associated parameters, to a 5-level paper tape punch unit. Update time by 10 seconds, recompute the 6 parameters, output an updated Time Identification Line and the 6 parameters, until 8640 sets of data (1 set for each 10-second interval over a 24-hour period) have been punched on paper tape.

In the Real Time Mode, execution time is critical, since after receipt of the first externally generated time signal, all operations described in (1) above must be completed in less than 10 seconds. Therefore, a major objective of the study was to devise a realistic measure of FADAC execution time in this mode. Toward this end, a program was designed and partially coded in FADAC mnemonics. The program was extended to include the Paper Tape Generator mode, to assure that all compute, interface, control, and tape generation problems were studied.

The software design should be considered a suggested approach to the solution of these problems, and represents only one of many possible approaches which could have been considered, given the tentative specifications which were provided at the time the study was initiated. In future final design of the computer program, system hardware must be fully defined.

DESCRIPTION OF FADAC

General

FADAC is a solid state, general purpose, digital computer designed to perform 12,500 additions or subtractions per second, and 711 multiplications or divisions per second. The computer has a rotating disc memory (1 disc revolution per 10 milliseconds) of 8192 fixed point words, each containing either a sign bit plus 31 magnitude bits, or a 32 bit instruction. Each instruction word contains the addresses of the operand and of the next command (a 1 + 1 system). The high speed operation of FADAC is a function of optimum coding and a unique multiplexing feature. Given minimum access coding, hardware design allows simultaneous, (1) operand read of the preceding instruction, (2) execution of the preceding instruction, (3) instruction read of the current instruction, (4) operand search of the current instruction, and (5) instruction search of the next instruction, all within one word time (78 micro-seconds). (Commands requiring more than one word time for execution delay computation by this additional execution time). The multiplexing characteristic of FADAC operation greatly increases its usefulness in real-time applications. Complete programming specifications are contained in Revision 1, Vol. IV of the Frankford Arsenal Notes on Development Type Materiel, FCDD-361, November 1962.

Input/Output

Input: Input to the computer is from the manual keyboard or the mechanical tape reader located on the control panel. External sources may be used to load the computer, such as:

a. Reproducer, Signal Data, AN/GSQ-64, which is a high speed photoelectric reader, designated the Memory Loading Unit (MLU). (Input at approximately 600 char/sec.)

b. Another FADAC

c. Gunnery Officer's Console

d. Other Fielddata or Teletype Equipment

e. Magnetic Tape Unit

Either Fielddata or Teletype code may be input, with automatic conversion to machine language.

Output: Output may be in the form of a visual display through the Nixie Tubes on the FADAC control panel, or to external output equipment such as:

1. Gunnery Officer's Console

2. Another FADAC

3. Battery Display Unit

4. Printer

5. Paper Tape Punch Unit

6. Magnetic Tape Unit

7. Other Fielddata or Teletype Equipment.

Output may be in Fielddata, 5-level teletype or 2-wire teletype codes, at rates of from 60 to 4000 char./sec., depending on the equipment used.

GENERAL PROGRAM DESCRIPTION

Figure 1 is a general flow diagram of the overall computer program developed to control both the Real Time and Paper Tape Generator Modes of operation. Note that the Initialization and General Computation Routines are common to both operating modes. To start the program, the SET-UP button is pressed, the Initialization Routine is executed and FADAC halts to allow the operator to select the desired operating mode. The COMPUTE button is depressed to select the Real Time Mode (RTM). The SEND button is depressed to select the Paper Tape Generator Mode (PTGM). The mode selected is reflected in the value stored in the programmed branching point (SW2). After SW2 is set, the program will automatically go through the General Computation Routine, test the value of SW2, generate the required output in a fixed order, update time, recompute the time-dependent equations 3 through 11, and repeat the cycle through a real (Mode I) or simulated (Mode II) 24 hour period.

The Initialization Routine is described in the flow diagram of figure 2. In this routine are preset the various indicators and addresses which control the paths through the program and the input of data. Start-time is input through FADAC keyboard and displayed; after which the fourteen input parameters defined in Table I are automatically read-in through the Mechanical Reader on the FADAC control panel. All inputs are converted from BCD to binary and stored.

A detailed flow-diagram of the General Computation Routine is shown in figure 3. The routine, coded in FADAC mnemonics, is contained in Appendix B. The mathematical equations used in the demonstration program were provided by the Satellite Communications Agency, and are shown in figure 3. Symbols used in the General Computation Routine (GCR) are defined in Table I and Appendix D.

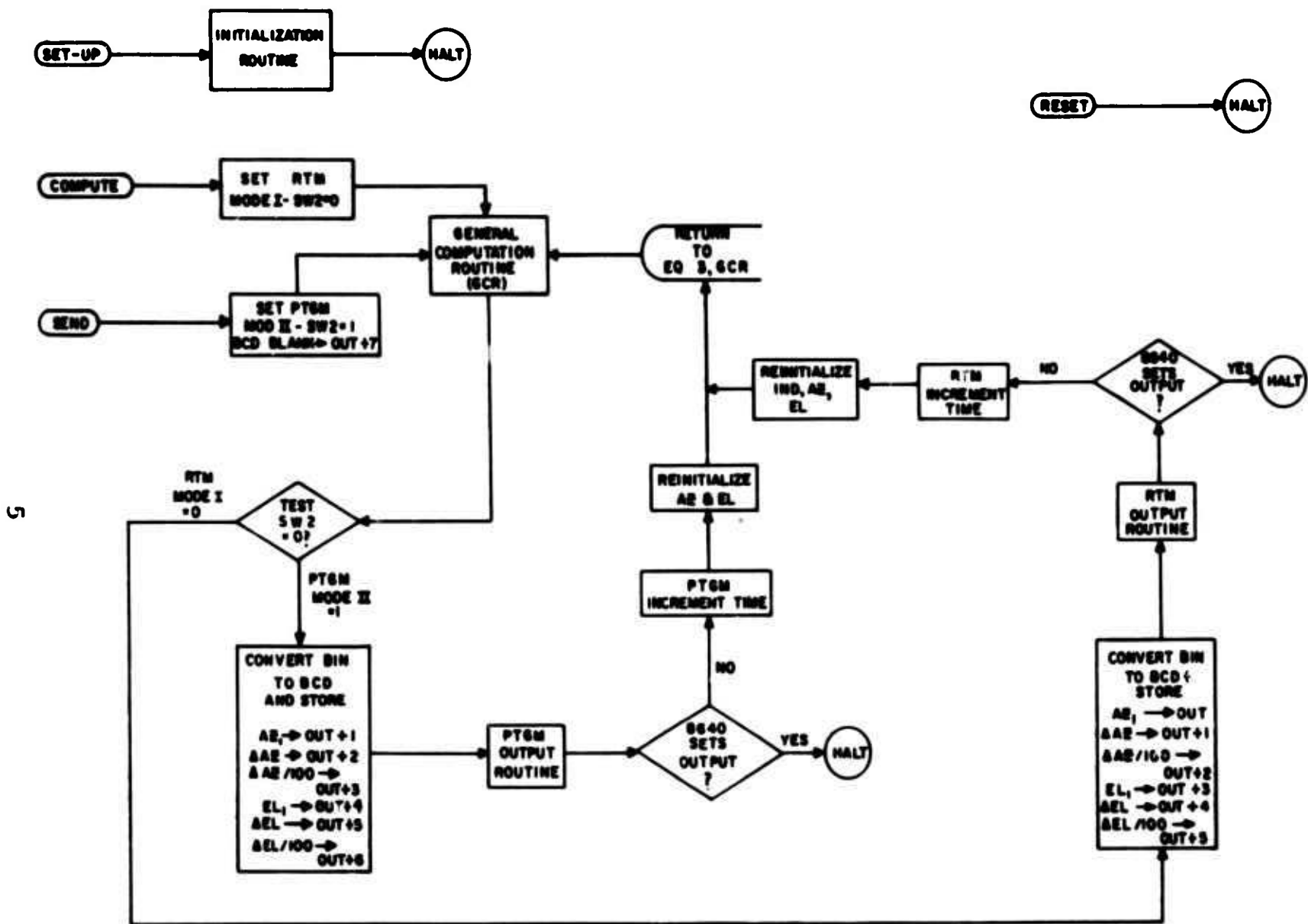

Figure 1. General Flow Diagram-Antenna Position Programmer System

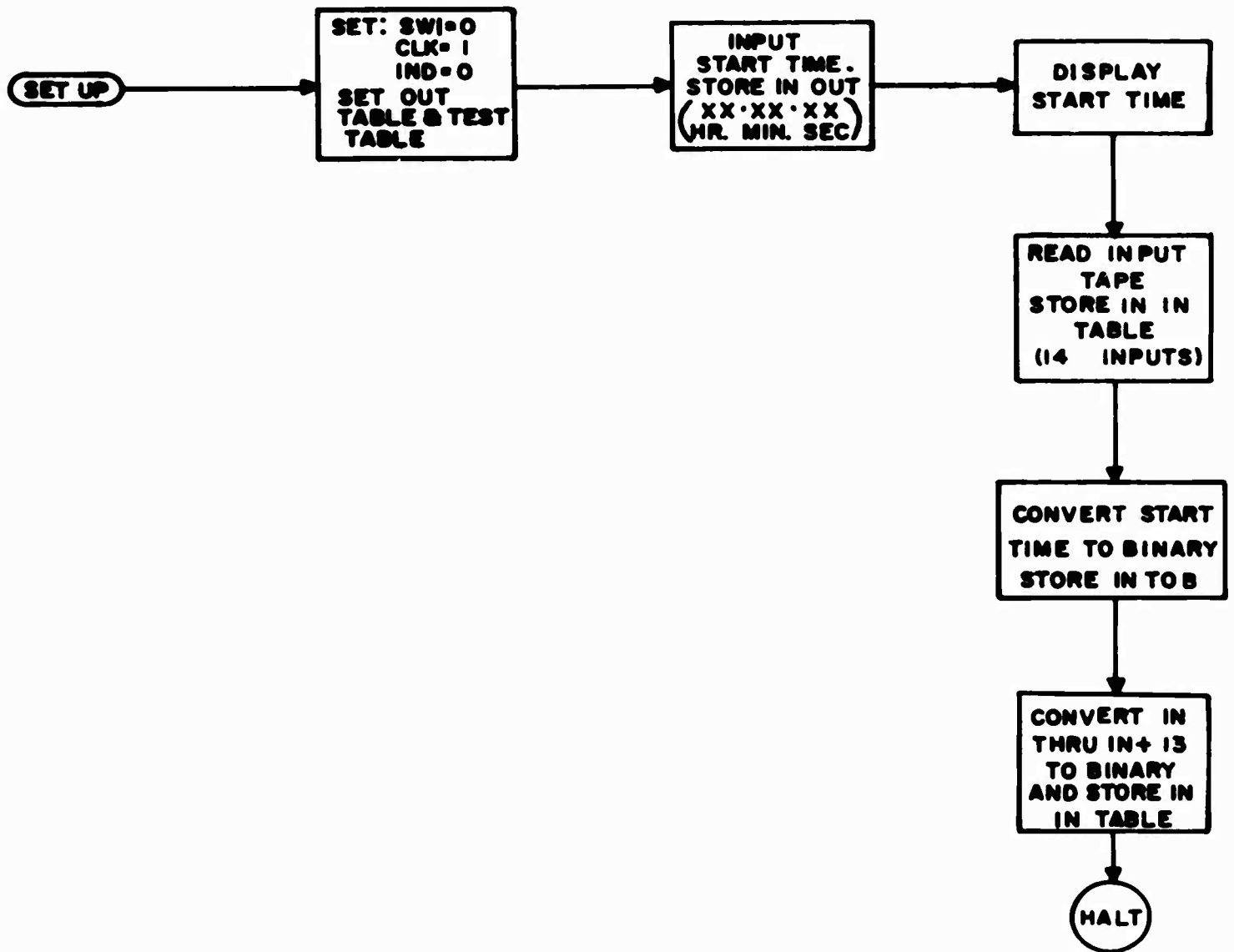

Figure 2. Flow Diagram-Initialization Routine

Table I. DEFINITION OF INPUTS

<u>"In" Table</u>	<u>Symbolic Notation as shown on Program Listing</u>	<u>Symbolic Notation as shown on Flow Diagrams</u>	<u>Definition</u>
In	THDS	Θ_{ds}	Geodetic latitude
In + 1	HS	HS	Height of station above sea level
In + 2	REE	R_e	Equatorial earth radius
In + 3	LAMS	λ_s	Geodetic longitude
In + 4	OI	OI	Orbital inclination
In + 5	DELO	$\Delta \Omega$	Nodal Motion
In + 6	DEL C	$\Delta \psi$	Perigee Motion
In + 7	PA	PA	Anomolistic Period
In + 8	MO	MO	Mean anomaly at epoch
In + 9	EORB	E_{orb}	Orbital eccentricity
In + 10	ANOM	ANOM	Semi-major axis normalized to R_e
In + 11	CHIO	ψ_o	Argument of perigee at epoch
In + 12	PHRA	PHRA	Right ascension of ascending node at epoch
In + 13	GHAR	GHAR	Greenwich hour angle of Aries at epoch.

NOTE: In through In + 13 are stored in 14 contiguous locations in FADAC memory.

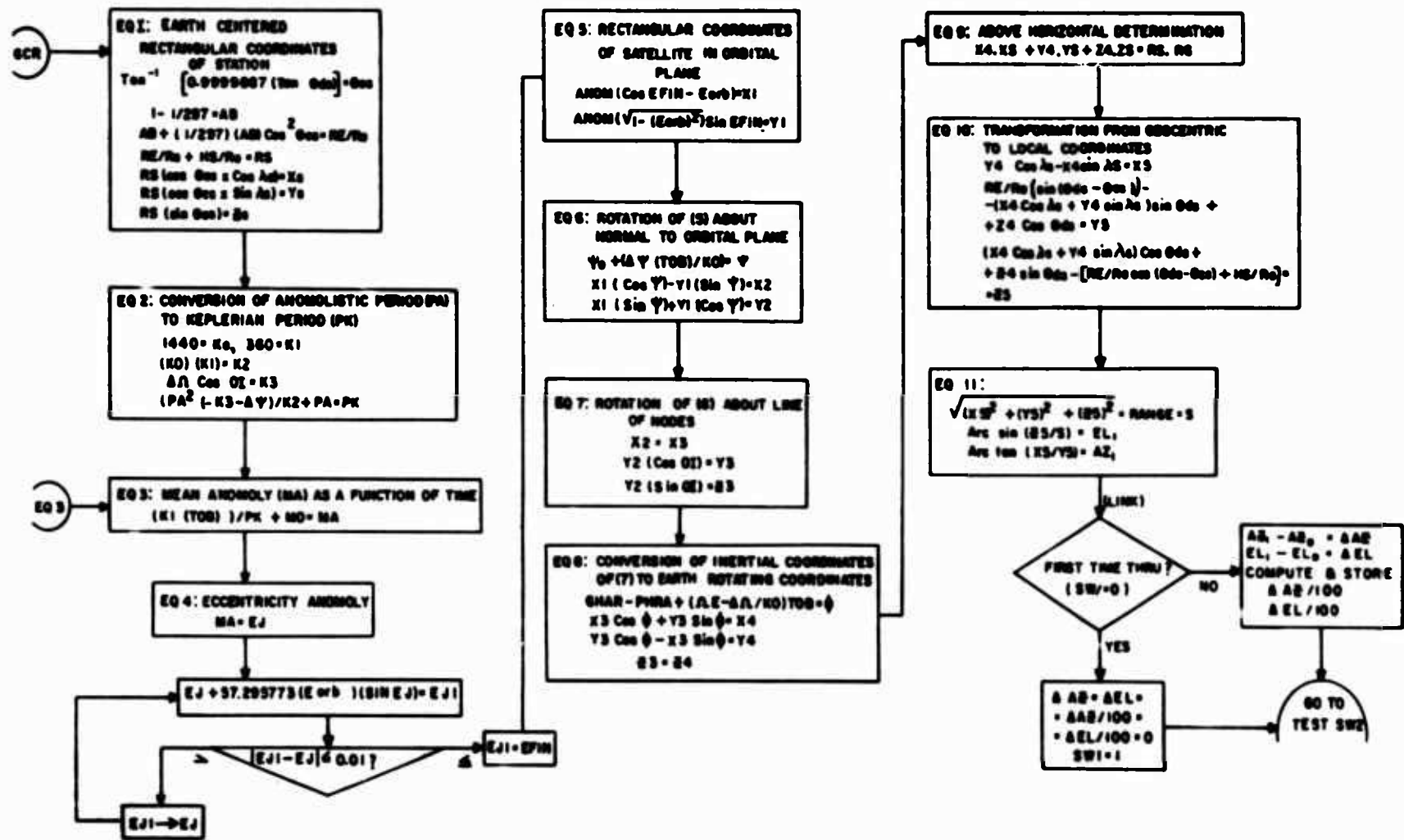

Figure 3. Flow Diagram-General Computation Routine (GCR)

DETAILED DESCRIPTION OF REAL TIME MODE

Hardware Considerations

FADAC operation in the Real Time mode will require the following peripheral equipment:

- (1) A high speed Memory Loading Unit (MLU) which is used to load the program into FADAC.
- (2) A timer, which will generate a signal every 10 seconds.
- (3) An Output Buffer, which is to be designed to accept BCD code generated by FADAC and transmit it to the six antenna position control channels.
- (4) A Remote Display Unit (RDU).

FADAC is designed to transmit data information over 5 data lines (for Teletype code) or 8 data lines (for Fielddata code), in parallel by character. In addition, six output control lines (OPL-1 thru OPL-6) are available to set or reset any desired external devices. In the Antenna Positioner System these six lines may be connected through the Output Buffer to each of the six position control channels. Thus, under program control, FADAC will transmit a given data word to a particular channel. However, this method would limit the number of output channels which can be controlled to the six output control lines available. As an alternative, the Output Buffer may contain a 6-position electronic stepping switch (or n-position, if additional control channels are required) designed to interpret a signal on one FADAC output line (OPL-1) as a command to reset the electronic switch to switch position 1, and to interpret a signal on a second FADAC output line (OPL-2) as a command to step through to the next switch position in sequence. The latter output buffer logic is assumed in the model program. (Note that the use of all six output control lines would not significantly affect the results in terms of execution time, or program complexity.)

BCD data will be transmitted from FADAC through the stepping switch to the particular antenna position channel defined by a given switch position, as shown in the following table:

<u>With the Stepping Switch in Position No.</u>	<u>Data is Transmitted to:</u>
1	AZ Channel
2	Δ AZ Channel
3	Δ AZ/100 Channel
4	EL Channel
5	Δ EL Channel
6	Δ EL/100 Channel

The logic assumed in this study requires the use of only two output control lines (OPL-1 and OPL-2)*freeing the remaining four lines for the control of other peripheral equipment.

Given an output command, FADAC hardware requires that a feedback signal be received by the computer after the output of each character. Failure to receive the feedback signal will halt output. In the design of the Output Buffer, either of two feedback methods may be used:

(1) **External Feedback:** Include a strobe feedback network in the design of the Output Buffer such that a feedback signal will be sent to the computer after each BCD character is received.

(2) **Free-running:** Wire the FADAC strobe network to accept its self-generated strobe as the required feedback after each character is transmitted. This does not require a change to FADAC hardware, since there is external access to the computer's feedback network through the J-10 output connector.

Figure 4 is a block diagram of the equipment required for FADAC operation in the Real Time Mode. The directed lines indicate the direction of data flow.

* A signal on OPL-1 is generated by an OD-1 command, on OPL-2 by an OD-2 command.

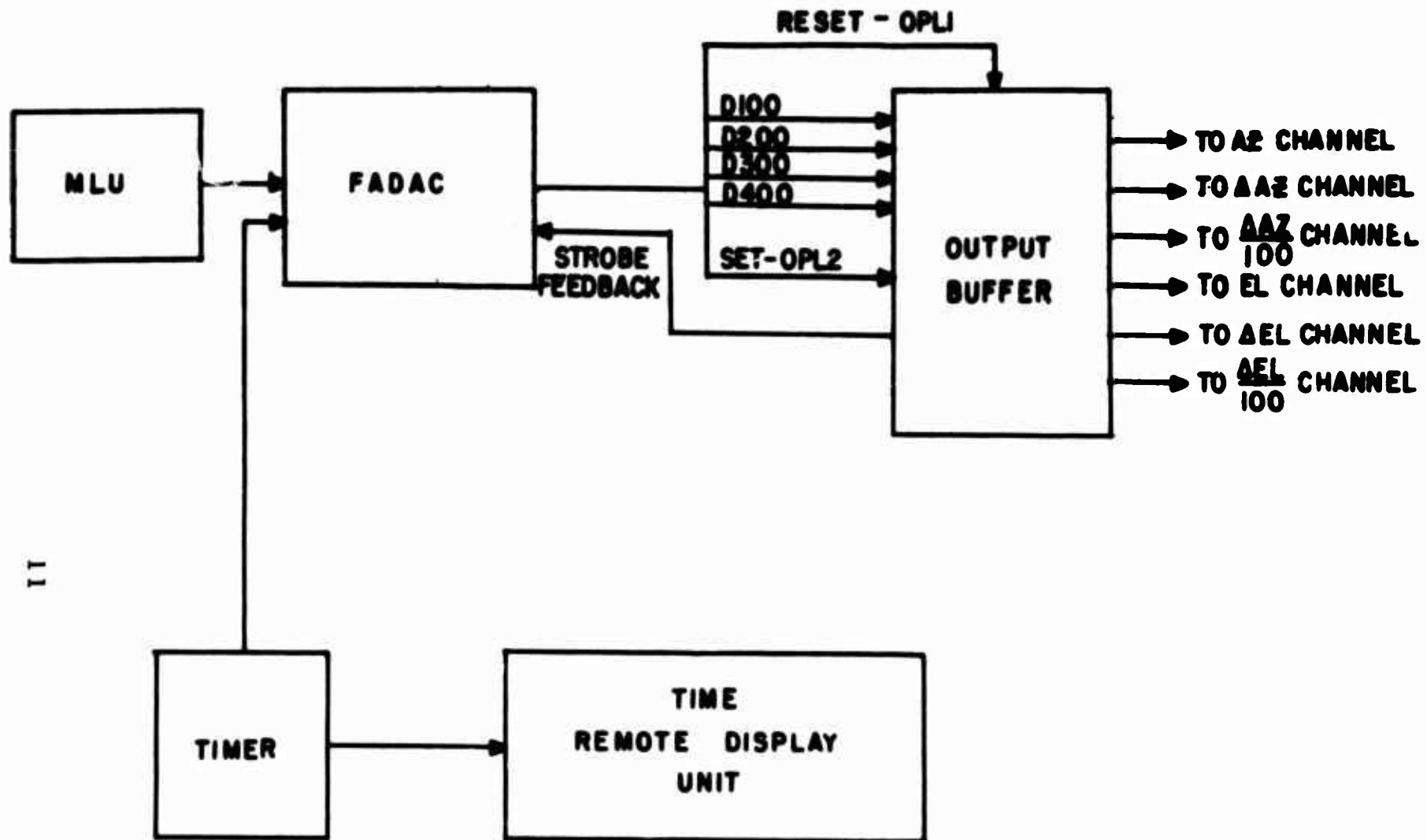

11

Figure 4. Block-Diagram of Equipment Required - Real Time Mode

Output Routine

A detailed flow diagram of the Real Time Mode Output Routine is contained in figure 5. To expedite output, the so-called "Out" and "Test" tables set by the Initialization Routine are stored in the R and Q loops respectively. Since output is by character rather than by word, the integrity of the contents of the two high speed loops is unaffected by the output commands. A listing of the mnemonic codes for the "Out" and "Test" loops, and the reinitialization of these loops, is contained in Appendix B.

Output Codes

FADAC will output BCD in either Baudot (TT) or Fielddata (FD) code. Study of the FD code showed that the four least significant bits of the eight bit FD code generated for decimal digits 0 through 9, and the decimal point, exactly duplicate the BCD codes for these characters. However, the FD codes for plus and minus are not equivalent to the BCD configuration.

It is assumed in this report that the RTM-Binary to BCD conversion routine contains a test for sign such that, if the sign is plus, the conversion routine is coded to generate four zero bits; if minus, the routine is coded to generate four one bits, rather than the BCD plus code (1010) or minus code (1011). Thus, in the RTM Output Routine, the sign of each parameter is tested with a single TPL command. If plus, an FD "U" is output (the four least significant bits of which are 1010); if minus, an FD "V" is output (the four least significant bits which are 1011). (See figure 5 - RTM Output Routine and Appendix B - Program Listing.) With the FADAC data lines D100 through D400 connected to the Output Buffer, and lines D500 through D800 open, BCD code can be transmitted through the electronic stepping switch circuit to a given antenna position control channel.

If higher output speeds are desired, output can be in the Alpha-4 mode rather than in Fielddata BCD. However, in the ALPHA -4 mode only 4 characters can be stored per FADAC word. It would therefore be necessary to use two FADAC locations for each 8-character word output. (It was assumed that the six output parameters could be adequately defined by 6 decimal digits, a decimal point and a sign, a total of 8 characters per output.) Also a conversion routine from binary to the desired Alpha -4

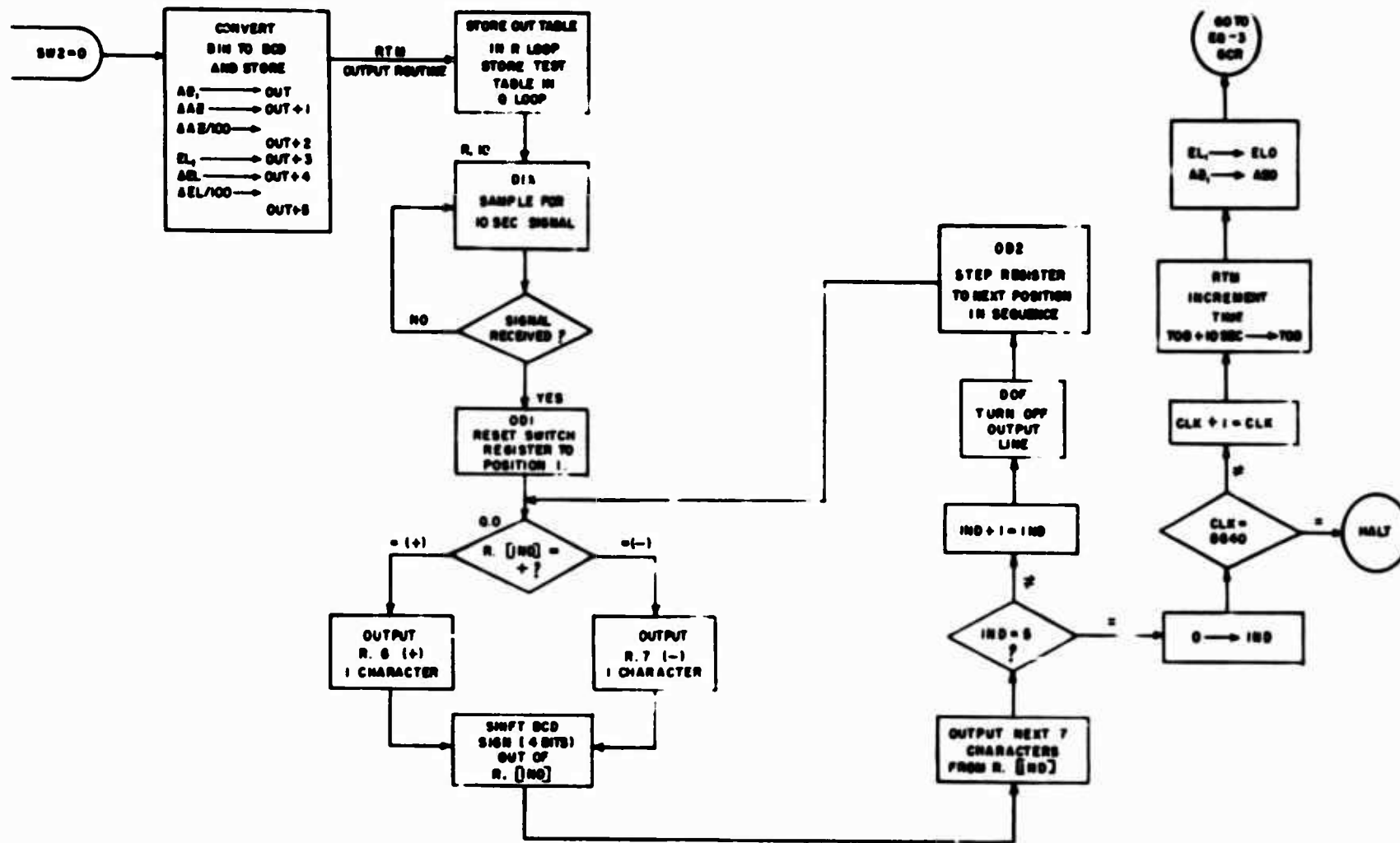

Figure 5. Flow Diagram - Real Time Mode Output Routine (RTM)

configuration would be required. However, this output mode should be considered if it is desired to form a special 8-bit code, 3 bits of which may be used to identify the control channel to which the data word is to be sent, 4 bits to define a BCD coded digit, decimal point or sign; and 1 bit of which may be suppressed by the receiving device. Fielddata BCD output is used in the demonstration program. FADAC output speeds for the two modes are as follows:

- (1) BCD is transmitted at the rate of 650 char/sec.
- (2) Alpha-4 is transmitted at the rate of 4000 char/sec.

Note that if FADAC is wired to generate its own feedback signal, (free running) the Output Buffer must accept data at a rate greater than the rate at which characters are output by FADAC.

Timing Estimate

To provide a basis for realistically estimating the time required to execute the FADAC program designed for the Real Time Mode (RTM) operation, the following elements of the program were coded in FADAC mnemonics:

- a. General Computation Routine (GCR) (fig. 3)
- b. RTM Output Routine (fig. 5)

Subroutines for the trigonometric functions, square root, BCD to Binary and Binary to BCD conversions, and special formats were not coded since the execution time of existing versions of similar or identical routines was known, or could be estimated.

A FADAC word time is 78 micro-second; a disc revolution, 10 milliseconds. Most instructions require one word-time for execution; while a STR, MPY, and DIV require 18-word times, and a LDR and LDQ require 16-word times. (See Appendix C for list of FADAC mnemonics.)

Execution time for each element coded was calculated as follows:

Let

X = Number of instructions per routine or equation

Y = 78×10^{-6} sec = 1 word-time

ΣY = Total minimum number of word times per routine or equation, in seconds

Z = Time required to execute each subroutine transferred to within each program element, in seconds

N = Total number of transfers to subroutines within each program element

D = .010 seconds = 1 disc revolution time

Then, Total execution time per program element

$$= \Sigma Y + \Sigma Z + (X/2)(D) + N(D)$$

Where the factor $(X/2)D$ is a worst case factor which was added to the estimated execution time to compensate for access time and scaling considerations which were not included in the sample coding. The factor $N(D)$ is an additional worst case factor which allows an entire disc revolution lost for each transfer to a subroutine.

To illustrate, the time required to set SW2 and execute Eq 1 was as follows:

$$X = 49$$

$$(X/2)D = 25 \times (.010) = .250 \text{ sec}$$

Subroutines:

Sin/Cos used twice at .020 ea = .040

Tan used once at .010 ea = .010

Arc tan used once at .030 ea = .030

$$\begin{aligned} \Sigma Z &= .080 \text{ sec} \\ N(D) &= 4(.010) = .040 \text{ sec} \\ \Sigma Y &= 236(78 \times 10^{-6}) = \underline{.018 \text{ sec}} \\ \text{Total Eq 1} &= .388 \text{ sec} \end{aligned}$$

Note that ΣY was based on 38 one-word time instructions plus 11 eighteen-word time instructions, a total of 236 word times.

Subroutines called by the program were assumed to require the following execution times:

<u>Routine</u>	<u>Time in Seconds</u>
BCD to Bin	.010 sec/char
Bin to BCD	.010 sec/char
Sin/Cos (both solutions)	.020 sec
Arc Sin	.030 sec
Arc Tan	.030 sec
Tan	.010 sec
Square Root	.010 sec

A summary of the estimated worst-case time required to execute all elements of the Real Time operating mode is contained in Table II. Note that execution time of the Initialization Routine is not included, since this routine is completed prior to entry into the Real Time operations.

DETAILED DESCRIPTION OF PAPER TAPE GENERATOR MODE

Hardware Considerations

Peripheral equipment required for FADAC operation in the Paper Tape Generator Mode is illustrated in the block diagram of figure 6. A commercially available 5, 7 or 8 level paper tape punch unit is connected to FADAC data lines through an appropriate interface. (Note that FA personnel have designed such an interface network for the Soroban Model LP-2 Paper Tape Punch Unit.)

Output Codes

The Satellite Communications Agency has indicated that any code may be used for the Tape Generator Mode which is less than 8 bits per

Table II. SUMMARY OF TIME REQUIRED TO EXECUTE FADAC PROGRAM FOR THE REAL-TIME OPERATING MODE

<u>Program Element</u>	<u>Estimated Execution Time (in seconds)</u>
Set SW2 and Execute Eq 1*	0.388
Eq 2	.160
Eq 3	.043
Eq 4	1.037**
Eq 5	.127
Eq 6	.150
Eq 7	.033
Eq 8	.180
Eq 9	.055
Eq 10	.363
Eq 11	.218
Linkage to RTM and Conversion to BCD	.764
RTM Output Routine	.416
Increment Time, Reinitialize AZ0, AZ1, E10, E11, and Return to Eq 3	<u>1.400</u>
Total	5.334

*Equations 1 through 11 constitute the General Computation Routine

**Assuming ten iterations

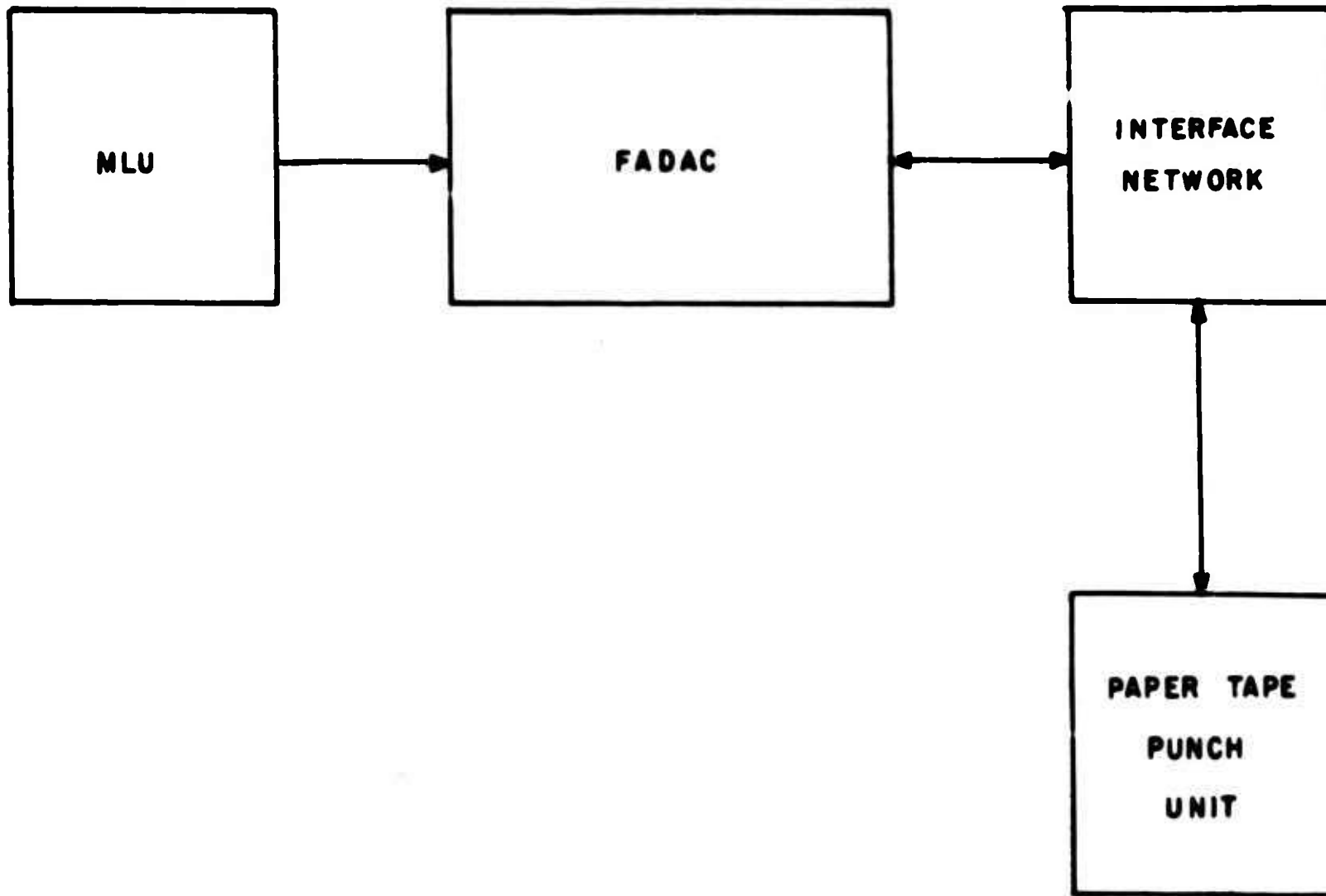

Figure 6. Block Diagram of Equipment Required - Paper Tape Generator Mode

character, to allow space on 8-level tape for the simultaneous print and punch of each character output. In the demonstration program, output is by word in 5-level (TT) code. It is assumed that since FADAC will not be used to control the Paper-Tape Track mode of operation, * equipment which is to be designed for this mode will be capable of decoding the 5-level tape code and generating the BCD code (or other format) desired. As an alternative to the 5-level code suggested in the demonstration program, the special 8-bit code described on p. 14 may be used. The first bit can be stripped by leaving data line D800 open, the channel-identifying 3-bits transmitted over lines D700 through D500, and the 4-bit BCD code transmitted over lines D400 through D100. Again, it will be necessary to design a special conversion routine and output by character in the high-speed Alpha-4 mode.

7

Special Features of the Mode II Program

Note that in the General Initialization Routine (fig. 2) start-time is entered through FADAC keyboard in BCD, and stored directly into location "Out". This quantity is ignored during output in the Real Time Mode. However, start-time is an important element in the Tape Generator Mode, since it is updated at 10-second intervals and serves as the Time Identification Line for each set of data output. A "set of data" is defined as the following parameters: (1) Time Identification Line, (2) AZ, (3) Δ AZ, (4) Δ AZ/100, (5) EL, (6) Δ EL, (7) Δ EL/100, (8) one word of BCD blanks. After the initial set is transmitted to the tape punch unit, time is up-dated by 10 seconds, and the new value of time stored in location "Out" in BCD, and in "TOB" in binary. See figure 7.

When the Tape Generator Mode is selected by depression of the SEND button, the programmed branching point (SW2) is set to output in Mode II, and location "Out + 7" is filled with BCD blanks. The blanks will generate a space (8-sprocket holes) between each set of data to assure that no characters will be lost when the tape is used as the source of data in the so-called Paper Tape Track mode. *

Tape Considerations

Normally, FADAC programs are punched on fanfold 5-level or 8-level paper tape, 1000 feet in length. This length is more than adequate for a program which will fill FADAC memory, since the tape will hold 10

*Described in Satellite Communications Agency Report 1011, 12 Jan 1965, FAPS.

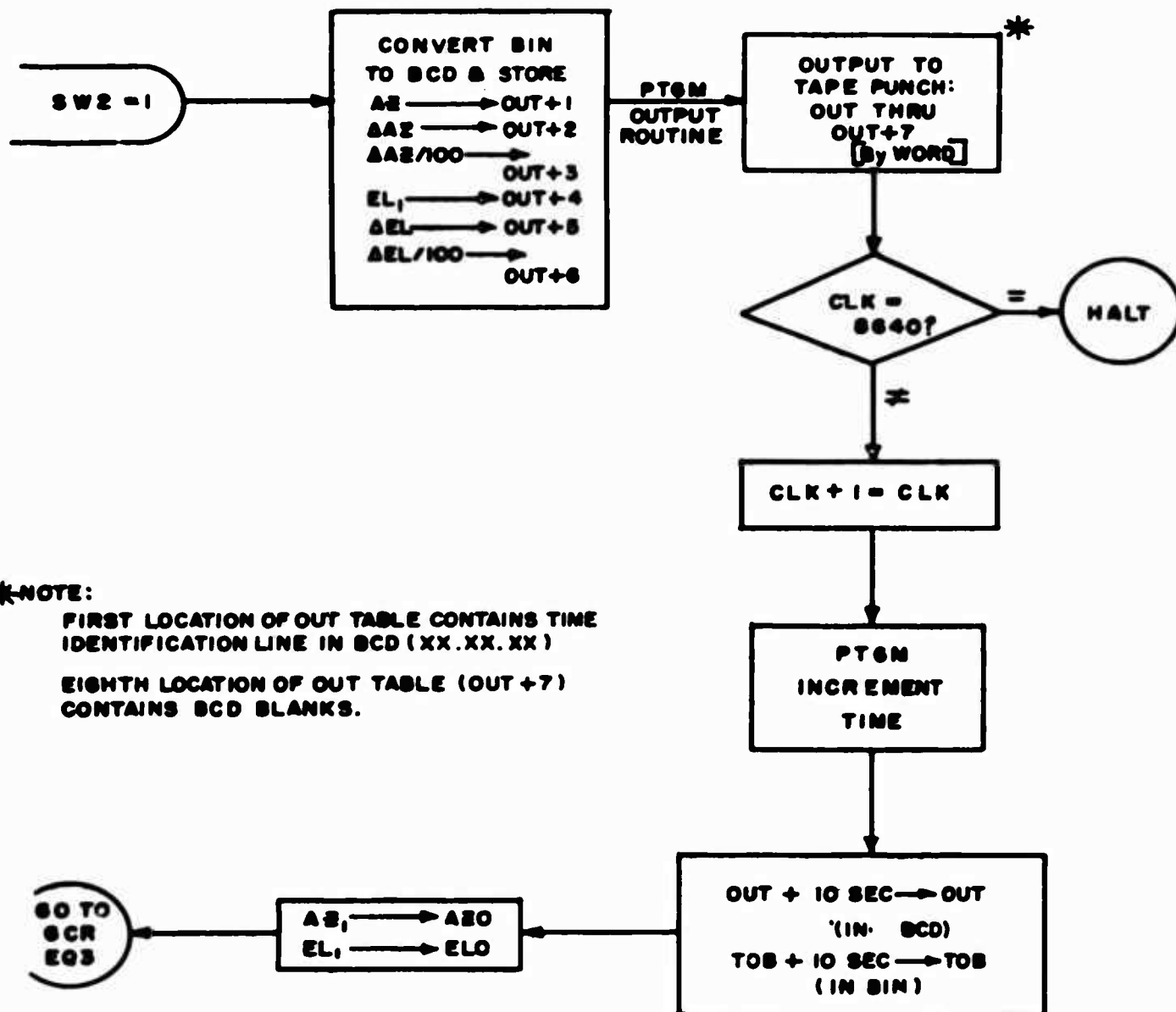

FIG 7 - FLOW DIAGRAM-PAPER TAPE GENERATOR MODE OUTPUT ROUTINE (PTGM)

Figure 7. Flow Diagram - Paper Tape Generator Mode Output Routine (PTGM)

characters per inch (120,000 char/tape). However, the tape generated during Mode II operation must contain 8640 sets of data, with each set made up of 64 characters, a total of 552,960 characters. Thus a tape for one 24-hour period must be greater than 4608 feet long. This problem was discussed with a tape manufacturer, who stated that he could not produce fan-folded tape in 5000-foot lengths, since it would be impossible to handle. Rolled paper tape was recommended. A motor driven jig can be designed to fix rolled tape reels to the MLU, and re-roll the tape as it passes beyond the read heads. As an alternative, many high-speed paper tape readers, designed to handle rolled paper tape, are commercially available.

CONCLUSIONS

The study proved that FADAC can perform all the required functions in both the Real Time and the Paper Tape Generator Modes.

The study proved that in the worst case, less than six seconds real time is required to allow FADAC to compute and transmit control data to the Antenna Position Control Channels. Therefore, the real time intervals specified for operation in the Real Time Mode can be significantly reduced.

RECOMMENDATIONS

In a review of the 11 equations solved to determine current values of AZ and EL, it was noted that Equation 9 of the General Computation Routine, "Above Horizon Determination", appears to serve no purpose. This equation calls for the solution of the product RS, RG . Guidance received from the Satellite Communication Agency indicated that if $RS^2 \leq RS, RG$, then the Satellite is above the horizon. However, there is no requirement to test

this relationship, or in any way change the computations or output regardless of the value of RS , RG . It is therefore recommended that this equation be deleted from the final version of the General Computation Routine.

It is recommended that rolled paper tape be used in the final version of this program. It is further recommended that the use of a commercially available high-speed paper tape reader, other than the MLU, be investigated.

APPENDIX A

CONVENTIONS USED IN CODING

1. All symbols begin with an alphabetic character, contain no less than 2 characters, either alphabetic or numeric (except when a register A, L or N, is referenced) and no more than 4 characters.

2. The coding format is as follows:

LOCATION Field - OP-CODE - OP Address, NI Address

3. The blank addressing, symbolic, and other coding conventions used are explained in the following example:

- | | | | |
|----|----|-----|---------------|
| 1. | Go | CLA | In + 5 |
| 2. | | MPY | KO |
| 3. | | ADD | |
| 4. | | DEC | 0.023 |
| 5. | | TPL | Go, No |
| 6. | No | ADD | In |
| 7. | | STA | Out + 2, Able |

Interpretation of Example:

Instruction (1): The Lo Field is labelled "Go". The Op Address "In + 5" references the sixth location in a table labelled "In" where "In" is the first location of the table, "In + 1", the second, etc. The blank NI is interpreted as "go to the next instruction in sequence", here Instruction (2).

Instruction (2): Multiply the contents of the A register by the value contained in the location labelled KO, and go to Instruction (3).

Instruction (3): Add the contents of Instruction (4) to the A register and go to Instruction (5). (Note that an instruction containing a blank Op Address is always followed by a decimal quantity. If both the Op Address and NI are blank, then the Op Address is interpreted as the next instruction in sequence and the NI is the next instruction plus 1.)

Instruction (4): The decimal quantity referenced in (3) and designated by the psuedo Op code "DEC".

Instruction (5): Test for plus; if plus, go to the location labelled "Go", if not, go to "No".

Instruction (6): Location "No" contains the command "add the contents of the first location of the table labelled 'In'", and go to Instruction (7).

Instruction (7): Store A in the third location of the table labelled "Out" and go to the location labelled "Able".

APPENDIX B

PROGRAM LISTING - REAL TIME MODE

COMP	TRA	SETQ	
SETQ	ZEL		SET SW2
	STL	SW2, GCR	GO TO GENERAL COMPUTATION ROUTINE
GCR	CLA	IN	EQUATION I THDS TO A
	TRA*	TAN	TRANSFER TO TAN ROUTINE
	STA	TAND	TAN THDS
	MPY		
	DEC	0.9999887	
	TRA*	A TAN	ARCTAN ROUTINE
	STA	THCS	
	TRA*	SINC	SIN/COS ROUTINE
	STL*	COTC	COS(THCS) TO A TO COTC
	STA	SITC	SIN(THCS)
	CLA	N	
	MPY	N	
	STA	SOCT	$\text{COS}^2 \text{THCS}$
	CLA		(1)
	DEC	18_	
	STA	0.1	

ZEL
DIV (297)
DEC 2978
STA D.0 (1/297 TO D.0)
CLA D.1
SUB D.0 (1-1/297):AB
STA D.1 AB TO D.1
MPY D.0
MPY 30CT
ADD D.1 $AB + (1/297(AB)(\cos^2 THCS)) = RE/REE$
STA D.0 RE/REE TO D.0 & RERE
STA RERE
CLA IN + 1 (HS)
ZEL
MPY IN + 2 HS/REE:HSRE
STA HSRE
ADD D.0 $HS/REE + RE/REE = RS$
STA RS
STA D.1 RS TO D.1
CLA IN + 3 LANS

	TRA*	SINC	
	STA	SILA	SIN LAMS
	STL	COLA	COS LAMS
	MPY	COTC	
	MPY	D.1	
	STA	YS	RS(SIN LAMS . COS THCS) : YS
	CLA	D.1	
	MPY	COTC	
	MPY	COLA	
	STA	XS	RS(COS THCS . COS LAMS) : XS
	CLA	D.1	
	MPY	SITC	
	STA	ZS, EQ2	RS(SIN THCS) : ZS
EQ2	CLA	KO	EQUATION 2
KO	DEC	1440B	
	MPY	K1	
K1	DEC	360B	KO(K1) : K2
	STA	D.1	K2 TO D.1
	CLA	IN + '	QI TO A
	TRA*	SINC	

	STA	SIOI	SIN OI
	STL	COOI	COS OI
	CLS	L	-COS OI TO A
	MPY	IN + 5	DELO
	SUB	IN + 6	DELC
	MPY	IN + 7	PA TO N
	MPY	N	
	STN	D.0	PA TO D.0
	ZEL		
	DIV	K2	$(((-\text{COS OI})(\text{DELO}) - \text{DELC})(\text{PA}^2)/\text{K2}) +$
	ADD	D.0	$+ \text{PA} =$
	STA	PK	$= \text{PK}$
	STA	D.1, EQ3	PK TO A AND D.1
EQ3	CLA	TOB	TIME IN MINUTES (EQUATION 3)
	ZEL		
	DIV	D.1	
	MPY	KI	$360(\text{TOB})/\text{PK}$
	ADD	IN + 8	MO
	STA	MA,	$(360(\text{TOB}))/\text{PK} + \text{MO} : \text{MA}$
ITER	STA	D.1, EQ4	MA TO D.1 (LET MA : EJ)

```

FC4   TRA*  SINC
      MPY   IN + 9      (SIN EJ) (EORR)
      MPY
      DEC   57.295773   180/PI
      ADD   D.1        EJ
      STA   D.0        EJ+1 : (SIN EJ(EORR)180/PI) + (EJ), EJ+1 TO D.0
      SUB   D.1
      ABS   A          /EJ+1-EJ/
      SUB
      DEC   0.01
      TZE   EQU, NOT
EQU   CLA   D.0        EJ+1
      STA   EFIN, EOS
NOT   TPL   , EQ
      CLA   D.0, ITER   (STORE EJ+1 IN EJ)
EOS   TRA*  SINC      EFIN IS IN A
      STA   SIEF      (SIN EFIN)
      STA   D.0        SIN EFIN TO D.0
      STL   COEF      COS EFIN
      CLA   L          COS EFIN TO A

```

	SUB	IN + 9	EORB
	MPY	IN + 10	ANOM
	STA	X1	(COS EFIN - EORB)ANOM : X1
	CLA	EORB	
	STA	D.1	EORB TO D.1
	MPY	D.1	
	CLS	A	
	ADD	ONE	$1 - (EORB)^2$
	TRA*	SORT	SQUARE ROOT ROUTINE
	MPY	D.0	SIN EFIN in D.0
	MPY	IN + 10	ANOM
	STA	Y1	$(\sqrt{1 - EORB^2}) \text{ SIN EFIN} \cdot \text{ANOM} = Y1$
	STA	D.1, EQ6	
EQ6	CLA	IN + 6	DELC
	MPY	TOB	
	ZEL		
	DIV	KO	
	ADD	IN + 11	CH10
	STA	CH?	DELC(TOB)/KO + CH10 : CHI
	TRA*	SINC	

	STA	SICH	SIN CHI
	STL	COCH	COS CHI
	MPY	D.1	Y1 IN D.1
	STA	D.0	Y1(SIN CHI) TO D.0
	CLA	X1	
	MPY	COCH	
	SUB	D.0	
	STA	X2	(-Y1(SIN CHI) + X1(COS CHI) : X2
	CLA	D.1	Y1 IN D.1
	MPY	N	(COS CHI IN N)
	STA	D.1	Y1 COS CHI TO D.1
	CLA	X1	
	MPY	SICH	
	ADD	D.1	
	STA	Y2, EQ7	Y1 COS CHI + X1 SIN CHI : Y2
EQ7	STA	D.1	Y2 TO D.1
	MPY	COOI	COS OI
	STA	Y3	Y2(COS OI) : Y3
	CLA	D.1	
	MPY	SIOI	SIN OI

	STA	Z3, EQ8	Y2(SIN OI) : Z3
			NOTE X2 EQUALS X3
EQ8	CLS	IN + 5	(DELO)
	ZEL		
	DIV	KO	KO : 1440
	ADD		
	DEC	0.250683	EARTH ROTATION RATE IN DEG/MIN (ΩE)
	MPY	TOB	
	SUB	IN + 12	PHRA
	ADD	IN + 13	GHR
	STA	PHI	
	TRA*	SINC	
	STA	SIPH	
	STA	D.0	SIN PHI TO D.0
	STL	COPM	
	STL	D.1	COS PHI TO D.1
	MPY	Y3	Y3 TO N
	STA	R.0	Y3(SIN PHI) TO R.0
	CLA	D.1	
	MPY	N	

	STA	R.2	Y3(COS PHI) TO R.2
	CLA	D.1	
	MPY	X3	X3 TO N
	STA	R.4	X3(COS PHI)
	CLS	D.0	
	MPY	N	(-X3(SIN PHI))
	ADD	R.2	
	STA	Y4	Y3 COS PHI - X3 SIN PHI : Y4
	CLA	R.4	
	ADD	R.0	
	STA	X4, EQ9	X3(COS PHI) + Y3 SIN PHI : X4
			(NOTE.. Z3 : Z4)
EQ9	MPY	XS	(X4)(XS) TO A
	STA	D.0	TO D.0
	CLA	Z5	
	MPY	Z3	Z3 : Z4
	STA	D.1	(Z5)(Z4) TO D.1
	CLA	YS	
	MPY	Y4	Y4 TO N
	ADD	D.0	

```

ADD    D.1          (YS)Y4 + (XS)X4 + ZS24 : RSRG)
STA    RSRG, E010

E010   CLA    COLA          COS LAMS TO D.0
STA    D.0
MPY    N            Y4 IN N
STA    R.0          Y4(COS LAMS) TO R.0
CLA    SILA          SIN LAMS TO D.1
STA    D.1
MPY    N
STA    R.3          Y4(SIN LAMS) TO R.3
CLS    D.1
MPY    X4           X4 TO N
STA    R.6          -X4(SIN LAMS) TO R.6
ADD    R.0          -X4(SIN LAMS) + Y4(COS LAMS):
STA    X5           : X5
STA    R.5
CLA    D.0
MPY    N
STA    R.10         X4(COS LAMS) TO R.10
ADD    R.3

```

STA R.4 X4(COS LAMS) + Y4(SIN LAMS) TO R.4
 CLA THDS
 TRA* SINC
 STA R.11 SIN THDS TO R.11
 STL R.12 COS THDS TO R.12
 MPY COTC (SIN THDS) (COS THCS)
 STA R.13 TO R.13
 CLA R.12 COS THDS
 MPY N
 STA R.14 (COS THDS)(COS THCS)
 CLA R.11
 MPY SITC
 ADD R.14 +(COS THDS COS THCS) + (SIN THDS SIN THCS)
 STA R.15 : R.15
 CLS R.12
 MPY N -(COS THDS)(SIN THCS) +
 ADD R.13 +(SIN THDS)(COS THCS)
 STA R.16 TO R.16
 CLS R.4 -() + COS LAMS + Y4 SIN LAMS)(SIN THDS)
 MPY R.11 TO

STA	R.17	R.17
CLA	N	(SIN THDS)
MPY	Z4	Z4 TO N
STA	R.2	Z4 SIN THDS TO R.2
CLA	N	(Z4)
MPY	R.12	
STA	R.1	Z4(COS THDS)
CLA	R.4	(X4 COS LAMS + Y4 SIN LAMS)
MPY	N	
STA	R.7	COS THDS(X4 COS LAMS + Y4 SIN LAMS)
CLA	R.16	(SIN THDS COS THCS - COS THDS SIN THCS)(RERE)-
MPY	RERE	
ADD	R.17	-(X4COS LAMS + Y4 SIN LAMS)(SIN THDS) +
ADD	R.1	+Z4(COS THDS) :
STA	Y5	:Y5
STA	R.3	Y5 TO R.3
CLS	R.15	-(SIN THDS SIN THCS + COS THDS COS THCS)(RERE) +
MPY	N	+
ADD	R.2	+ Z4 SIN THDS +
ADD	R.7	+ (X4 COS LAMS + Y4 SIN LAMS) COS THDS +

	ADD	MSRE	♦ MS/REE :
	STA	Z5	: Z5
	STA	R.12, EQ11	Z5 TO R.12
EQ11	MPY	A	Z5 IS IN A
	STA	D.0	$(Z5)^2$ TO D.0
	CLA	R.3	Y5
	MPY	A	
	STA	D.1	$(Y5)^2$ TO D.1
	CLA	R.5	X5 TO A
	MPY	A	$(X5)^2$ IN A
	ADD	D.0	
	ADD	D.1	
	TRA*	SORT	TRANSFER TO SQUARE ROOT ROUTINE
	STA*	RANG	$(X^2 + Y^2 + Z^2)$: RANG, RANG TO N
	CLA	R.12	Z5
	ZEL		
	DIV	N	Z5/RANG
	TRA*	ASIN	TRANSFER TO ARC SIN ROUTINE
	STA	EL1	ARC SIN Z5/RANG : EL1
	CLA	X5	

ZEL

DIV Y5

TRAP ATAN TRANSFER TO ARC TAN ROUTINE

STA AZI, LINK $\tan^{-1}(X5/Y5) = AZI$

LINKAGE FROM GENERAL COMPUTE TO ORTM OUTPUT ROUTINE

LINK CLA SW1

TZE YES, NO TEST 1ST TIME THRU SW1

YES ZEL FIRST TIME

STL OLAZ

STL OAZ DEL AZ : DEL AZ/100 :

STL DLEL : DEL EL : DEL EL/100 = 0

STL DEL, TSM2

NO CLA AZI NOT FIRST TIME

SUB AZO

STA OLAZ COMPUTE DEL AZ

ZEL

DIV 100

STA OAZ COMPUTE DEL AZ/100

CLA ELI

SUB FLO

	STA	OEL	COMPUTE DEL EL
		ZEL	
	DIV	100	
	STA	DEL, TSW2	COMPUTE DEL EL/100
TSW2	CLA	SW2	
	TZE	RTM, PTPD	TEST SW2
RTM	TRAP	QBCD	TRANSFER TO BCD CONVERSION LOOP FOR CONVERSION OF 6 RTM OUTPUT PARAMETERS
	LDR	OUT	OUT TABLE TO R
	LDR	TEST, R.10	TEST TABLE TO Q, GO TO R.10

RTM OUTPUT ROUTINE

OUT TABLE AS LOADED INTO R LOOP BY LINKAGE ROUTINE

R.0		(AZ)
R.1		(ΔAZ)
R.2		(ΔAZ/100)
R.3		(EL)
R.4		(ΔEL)
R.5		(ΔEL/100)
R.6	FD(+)	
R.7	FD(-)	

R.10	DIA	• R.11	SAMPLE TIME ON LINE M
R.11	ALS2	• R.12	SHIFT SIGNAL ON LINE M TO SIGN POSITION
R.12	TPL	R.10, R.15	
R.13	CLA	INIT, REQ	
R.14	DEC	1B31	
R.15	OD1	• Q.0	RESET SWITCH TO POSITION 1
R.16	ODF	• R.17	TURN OFF OUTPUT LINE
R.17	OD2	• Q.0	STEP SWITCH TO NEXT SWITCH POSITION
INIT	CLA	R.0, Q.1	
REQ	STA	TEST, NEXT	

TEST TABLE AS LOADED INTO Q LOOP BY LINKAGE ROUTINE

Q.0	CLA	(R.0), Q.1	BRING R.(IND)
Q.1	TPL	Q.2, Q.3	TEST SIGN
Q.2	CLA	R.6, Q.4	BRING BCD(+)
Q.3	CLA	R.7, Q.4	BRING BCD(-)
Q.4	WE4	Q, Q.5	WRITE SIGN
Q.5	CLA	(R.0), Q.6	R.(IND) TO AR
Q.6	ALS 4	• Q.7	SHIFT OUT BCD SIGN
Q.7	EDF 6	• Q.10	OUTPUT NEXT 7 CHARACTERS
Q.10	CLA	Q.0, Q.11	

Q.11	SUB	Q.12, Q.13	TEST (IND)
Q.12	CLA	R.5, Q.1	
Q.13	TZE	R.13, Q.14	IF IND = 5, REINITIALIZE TEST LOOP
Q.14	CLA	Q.0, Q.15	IF NOT IND + 1 = IND
Q.15	ADD	R.14, Q.16	
Q.16	STA	Q.0, Q.17	
Q.17	STO	Q.5, R.16	
NEXT	STO	TEST + 5, CHK	
CHK	CLA	CLK,	
	SUB		
	DEC	8640831	
	TZE	STOP, UP	
STOP	HALT	0, 0	
UP	CLA	CLK	
	ADD	R.14	
	STA	CLK,	GO TO INCREMENT TIME ROUTINE

APPENDIX C

FADAC MNEMONICS

	<u>Mnemonic</u>	<u>Operation</u>
I.	Arithmetic	
	ADD	Add
	SUB	Subtract
	MPY	Multiply
	CLA	Clear & Add
	CLS	Clear & Subtract
	DIV	Divide
II.	Store & Load	
	STN	Store N
	STD	Store D
	STA	Store A
	STL	Store L
	STP	Store (N1) Prog Ad
	STO	Store Op Ad
	STR	Store R loop
	LDR*	Load R loop
	LDQ	Load Q loop
III.	Transfer	
	TPL	Transfer on Plus
	TZE	Transfer on Zero
	TRA	Unconditional Transfer
	TOV	Transfer on Overflow

	<u>Mnemonic</u>	<u>Operation</u>
IV.	Shift & Cycle	
	ARC	A right cycle
	ARS	A right shift
	ALC	A left cycle
	ALS	A left shift
	LRC	Long right cycle
	LRS	Long right shift
	LLC	Long left cycle
	LLS	Long left shift
V.	Special	
	EXT	Extract
	EQS	Equal Search
	GES	Greater than or Equal Search
	HLT	Halt
	HCM	Halt Compute Mode
	ICM	Initiate Compute Mode
	ZEL	Zero L
	IDM	Initiate Display Mode
	HDM	Halt Display Mode
	ABS	Take absolute Value
	RML	Replace A on Minus from L
	RMN	Replace A on Minus from N
VI.	Serial I/O	
	DIA	Discrete Input to A
	DOF	Discrete Outp Off
	ODI	Outp Dev Stepping - 1

<u>Mnemonic</u>	<u>Operation</u>
VI. Serial I/O (Cont'd)	
OD2	Outp Dev Stepping - 2
OD3	Outp Dev Stepping - 3
ID1	Inp Dev Stepping - 1
ID2	Inp Dev Stepping - 2
ID3	Inp Dev Stepping - 3
NSL	No Solution Light

<u>Mnemonic</u>	<u>Interpretation</u>
VII. Parallel Input/Output Command Summary	
WEOT	Write FADAC to Ext Dev in Oct (TT)
WFOT	Write FADAC to FADAC in Oct (TT)
WEOF	Write FADAC to Ext Dev in Oct (FD)
WFOF	Write FADAC to FADAC in Oct (FD)
WEDT	Write FADAC to Ext Dev Dec (TT)
WFDT	Write FADAC to FADAC Dec (TT)
WEDF	Write FADAC to Ext Dev Dec (FD)
WFDF	Write FADAC to FADAC Dec (FD)
WE6	Write FADAC to Ext Dev α -6
WF6	Write FADAC to FADAC α -6
WE5*	Write FADAC to Ext Dev α -5
WF5*	Write FADAC to FADAC α -5
WE4	Write FADAC to Ext Dev α -4
WF4	Write FADAC to FADAC α -4
REO	Read Ext Dev in Oct
RTO	Read Tape Dev in Oct
RKO	Read Keyboard in Oct

Mnemonic

Interpretation

VII. Parallel Input/Output Command Summary (Cont'd)

RED	Read Ext Dev in Dec
RTD	Read Tape Dev in Dec
RKD	Read Keyboard in Dec
RE6	Read Ext Dev in α-6
RT6	Read Tape Dev in α-6
RM6	Read Mag Tape in α-6
RK6	Read Keyboard in α-6
RE5	Read Ext Dev in α-5
RT5	Read Tape Dev in α-5
RM5	Read Mag Tape in α-5
RK5	Read Keyboard in α-5

APPENDIX D

DEFINITION OF SYMBOLS OTHER THAN INPUTS,
USED IN GENERAL COMPUTATION ROUTINE

<u>Symbolic Notation as Shown on Program Listing</u>	<u>Symbolic Notation as Shown on Flow Diagram</u>	<u>Definition</u>
THCS	Ocs	Geocentric Latitude
1/297	1/297	Eccentricity Constant
XS, YS, ZS	Xs, Ys, Zs	Station Coordinates
TOB	TOB	Time from Epoch (in binary)
EJ	EJ	Let MA = EJ and iterate until $ EJ1 - EJ \leq 0.01^\circ$; then EFIN = EJ1, and EJ1 = result of each iteration. (See Eq 4.)
ANOM	ANOM	Semi-major axis normalized to Re
X1, Y1	X1, Y1	Satellite Coordinates in Orbit Plane
CHIO	ψ_0	Argument of Perigee at Epoch
X2, Y2	X2, Y2	Satellite Coordinates Normal to Orbital Plane
X3, Y3, Z3	X3, Y3, Z3	Where X3 is along Ascending Node, Y3 is in equatorial plane 90° E of X3 and Z3 is along Earth's axis.
G HAR	G HAR	Greenwich Hour Angle of Aries at Epoch
0.250683	ω_E	Earth's rotation rate in degree/min.

<u>Symbolic Notation as Shown on Program Listing</u>	<u>Symbolic Notation as Shown on Flow Diagram</u>	<u>Definition</u>
X4, Y4, Z4	X4, Y4, Z4	Earth Rotating Coordinates
RS	RS	Radius center of Earth to station
RG	RG	Radius center of Earth to satellite
X5	X5	Eastward)
Y5	Y5	Northward) Local Coordinates
Z5	Z5	Zenith)

Unclassified
Security Classification

DOCUMENT CONTROL DATA - R&D

(Security classification of title, body of abstract and indexing annotation must be entered when the overall report is classified)

1. ORIGINATING ACTIVITY (Corporate author) FRANKFORD ARSENAL Philadelphia, Pa. 19137	2a. REPORT SECURITY CLASSIFICATION Unclassified
	2b. GROUP

3. REPORT TITLE
**COMPUTER, GUN DIRECTION, M18 (FADAC)
APPLICABILITY IN DEFENSE COMMUNICATIONS SATELLITE ANTENNA
POSITIONER SYSTEM**

4. DESCRIPTIVE NOTES (Type of report and inclusive dates)
Final Report

5. AUTHOR(S) (Last name, first name, initial)
SMOLEN, Helen

6. REPORT DATE October 1965	7a. TOTAL NO OF PAGES 48	7b. NO OF REFS
---------------------------------------	------------------------------------	----------------

8a. CONTRACT OR GRANT NO. AMCMS Code 5331.12.918 b. PROJECT NO. 1R322101D253 c. d.	8b. ORIGINATOR'S REPORT NUMBER(S) R-1777
	8c. OTHER REPORT NO(S) (Any other numbers that may be assigned this report)

10. AVAILABILITY/LIMITATION NOTICES
Report authorized for release to CFSTL.

11. SUPPLEMENTARY NOTES	12. SPONSORING MILITARY ACTIVITY U. S. Army Satellite Communications Agency
-------------------------	---

13. ABSTRACT

The study described in this report was undertaken at the request of the U. S. Army Satellite Communications Agency, Ft. Monmouth, N. J., to determine the suitability of Computer, Gun Direction, M18 (FADAC), as the control unit in an Antenna Position Programmer System designed to acquire and track earth satellites.

Results of the study show that FADAC has the capability of performing the required functions, can interface with the remainder of the system, and, at operator's option, either output control data to the antenna positioner within the real time specified, or generate a punched paper tape.

14. KEY WORDS	LINK A		LINK B		LINK C	
	ROLE	WT	ROLE	WT	ROLE	WT
Antenna Position Programmer System Satellites, tracking Computer, Gun Direction M18 (FADAC)						

INSTRUCTIONS

1. ORIGINATING ACTIVITY: Enter the name and address of the contractor, subcontractor, grantee, Department of Defense activity or other organization (*corporate author*) issuing the report.

2a. REPORT SECURITY CLASSIFICATION: Enter the overall security classification of the report. Indicate whether "Restricted Data" is included. Marking is to be in accordance with appropriate security regulations.

2b. GROUP: Automatic downgrading is specified in DoD Directive 5200.10 and Armed Forces Industrial Manual. Enter the group number. Also, when applicable, show that optional markings have been used for Group 3 and Group 4 as authorized.

3. REPORT TITLE: Enter the complete report title in all capital letters. Titles in all cases should be unclassified. If a meaningful title cannot be selected without classification, show title classification in all capitals in parenthesis immediately following the title.

4. DESCRIPTIVE NOTES: If appropriate, enter the type of report, e.g., interim, progress, summary, annual, or final. Give the inclusive dates when a specific reporting period is covered.

5. AUTHOR(S): Enter the name(s) of author(s) as shown on or in the report. Enter last name, first name, middle initial. If military, show rank and branch of service. The name of the principal author is an absolute minimum requirement.

6. REPORT DATE: Enter the date of the report as day, month, year, or month, year. If more than one date appears on the report, use date of publication.

7a. TOTAL NUMBER OF PAGES: The total page count should follow normal pagination procedures, i.e., enter the number of pages containing information.

7b. NUMBER OF REFERENCES: Enter the total number of references cited in the report.

8a. CONTRACT OR GRANT NUMBER: If appropriate, enter the applicable number of the contract or grant under which the report was written.

8b, 8c, & 8d. PROJECT NUMBER: Enter the appropriate military department identification, such as project number, subproject number, system numbers, task number, etc.

9a. ORIGINATOR'S REPORT NUMBER(S): Enter the official report number by which the document will be identified and controlled by the originating activity. This number must be unique to this report.

9b. OTHER REPORT NUMBER(S): If the report has been assigned any other report numbers (*either by the originator or by the sponsor*), also enter this number(s).

10. AVAILABILITY/LIMITATION NOTICES: Enter any limitations on further dissemination of the report, other than those imposed by security classification, using standard statements such as:

- (1) "Qualified requesters may obtain copies of this report from DDC."
- (2) "Foreign announcement and dissemination of this report by DDC is not authorized."
- (3) "U. S. Government agencies may obtain copies of this report directly from DDC. Other qualified DDC users shall request through _____."
- (4) "U. S. military agencies may obtain copies of this report directly from DDC. Other qualified users shall request through _____."
- (5) "All distribution of this report is controlled. Qualified DDC users shall request through _____."

If the report has been furnished to the Office of Technical Services, Department of Commerce, for sale to the public, indicate this fact and enter the price, if known.

11. SUPPLEMENTARY NOTES: Use for additional explanatory notes.

12. SPONSORING MILITARY ACTIVITY: Enter the name of the departmental project office or laboratory sponsoring (*paying for*) the research and development. Include address.

13. ABSTRACT: Enter an abstract giving a brief and factual summary of the document indicative of the report, even though it may also appear elsewhere in the body of the technical report. If additional space is required, a continuation sheet shall be attached.

It is highly desirable that the abstract of classified reports be unclassified. Each paragraph of the abstract shall end with an indication of the military security classification of the information in the paragraph, represented as (TS), (S), (C), or (U).

There is no limitation on the length of the abstract. However, the suggested length is from 150 to 225 words.

14. KEY WORDS: Key words are technically meaningful terms or short phrases that characterize a report and may be used as index entries for cataloging the report. Key words must be selected so that no security classification is required. Identifiers, such as equipment model designation, trade name, military project code name, geographic location, may be used as key words but will be followed by an indication of technical context. The assignment of links, rules, and weights is optional.