



Fast Track[®] C600[™] User Guide

Legal Notices

This guide is copyrighted ©2011 by Avid Technology, Inc., with all rights reserved. Under copyright laws, this guide may not be duplicated in whole or in part without the written consent of Avid.

Avid, the Avid logo, Fast Track, M-Audio and Pro Tools are either trademarks or registered trademarks of Avid Technology, Inc. All other trademarks contained herein are the property of their respective owners.

Product features, specifications, system requirements, and availability are subject to change without notice.

Guide Part Number 9329-65123-00 REV A 06/11

Documentation Feedback

At Avid, we are always looking for ways to improve our documentation. If you have comments, corrections, or suggestions regarding our documentation, email us at **techpubs@avid.com**.

contents

Chapter 1. Welcome to Fast Track C600	1
Fast Track C600 Features	1
System Requirements and Compatibility	2
Conventions Used in This Guide	2
About www.avid.com	2
Chapter 2. Fast Track C600 Hardware Overview	3
Fast Track C600 Top Panel Features	3
Fast Track C600 Back Panel Features	6
Fast Track C600 Front Panel Features	8
Chapter 3. Fast Track C600 Installation	9
Installing Fast Track C600 Drivers	9
Chapter 4. Hardware Connections	11
Connecting Headphones	11
Connecting a Sound System	11
Connecting Audio Inputs	12
Connecting a Microphone	12
Connecting Instruments to the Fast Track C600	14
MIDI Connections	16
Chapter 5. The Driver Control Panel	18
Presets	19
Layouts	19
Additional Functions	20
Monitor Mixes	25
Using the Monitor Mixer	26

- Chapter 6. The Multi Button and Transport Buttons** 29
 - Overview 29
 - Multi and Transport Control Button Settings 30
 - About Multi Button Macros 32
 - Configuring the Multi Button (Building a Macro). 33
 - Configuring the Transport Buttons 34

- Chapter 7. Recording with Fast Track C600** 35
 - Recording Audio Tracks 35
 - Recording Instrument Tracks. 37

- Appendix A. Troubleshooting** 38
 - Check Your Connections 38
 - Check the Fast Track C600 Drivers 39
 - Music Software Configuration 39
 - Before Updating Your System 40
 - Before You Call Avid Support. 40

- Appendix B. Compliance Information** 41
 - Environmental Compliance 41
 - EMC (Electromagnetic Compliance) 42
 - Safety Compliance 42

- Appendix C. Warranty** 44

Welcome to Fast Track C600

Thank you for purchasing the Fast Track® C600 audio interface.

Fast Track C600 is a 6-input, 8-output audio interface that connects to your computer through USB 2.0. The interface features high-quality analog and digital connectivity, MIDI ports, sophisticated monitoring and control functionality, and pristine audio quality at sample rates up to 24-bit/96 kHz.

Fast Track C600 Features

Fast Track C600 provides the following:

- Four channels of analog audio input with high-quality microphone preamps and switchable 48V phantom power
 - Analog input jacks include four back panel XLR/TRS combo-jacks and two front panel 1/4-inch TS jacks
 - XLR/Line or Instrument input selector for input channels 1 and 2.
 - Switchable Pad to prevent loud signals from overloading the analog inputs
- Two channels of S/PDIF digital input and output
 - S/PDIF inputs and outputs are completely independent from the analog inputs and outputs. However, the S/PDIF outputs can be set to mirror any of the analog output pairs, if desired
- Up to a total of six channels of input, using analog and digital inputs simultaneously
- Up to a total of eight channels of output, using analog and digital outputs simultaneously
- Two 1/4-inch (TRS) stereo headphone output with adjustable level controls

⚠ *To use all of the inputs and outputs of the interface, Fast Track C600 must be powered using the 5V power adapter included with the product. While it is possible to power the interface through the USB cable without the power supply, please note that due to inherent power limitations of the USB bus, analog inputs 3-4, analog outputs 5-6, and headphone output 2 will not be available.*

- Independent gain controls and level meters for each analog input channel
- One MIDI In and one MIDI Out port, providing 16 MIDI input channels and 16 MIDI output channels
- Six balanced 1/4-inch TRS analog line-level outputs
- Three Output Selector buttons for quick and easy switching between multiple pairs of speakers
- 24-bit A/D and D/A converters, supporting sample rates up to 96 kHz

- Low Latency Monitoring (LLM) with adjustable balance between input and playback
- On-board reverb and delay effects (useful for monitoring while recording vocals or instruments)
- Assignable Transport buttons for controlling playback, recording, and other functions
- Multi-function, assignable Soft button
- USB 2.0 operation

 *Fast Track C600 may not function properly if connected to a USB hub. Please connect directly to your computer's USB port whenever possible.*

System Requirements and Compatibility

A DVD drive is required to install the drivers and software provided with this product.

For complete system requirements and a list of qualified operating systems and recording applications, visit:

www.avid.com/m-audio

Conventions Used in This Guide

The following symbols are used to highlight important information:

 *User Tips are helpful hints for getting the most from your system.*

 *Important Notices include information that could affect your data or the performance of your system.*

 *Cross References point to related sections in this guide.*

About www.avid.com

The Avid® website (www.avid.com) is your best online source for information to help you get the most out of your Fast Track C600. The following are just a few of the services and features available.

Product Registration Register your purchase online at www.avid.com/support.

Support and Downloads Contact Avid Customer Success (technical support); download software updates and the latest online manuals; browse the Compatibility documents for system requirements; search the online Knowledge Base.

Products and Developers Learn about Avid products; download demo software or learn about our Development Partners and their plugins, applications, and hardware.

News and Events Get the latest news from Avid.

chapter 2

Fast Track C600 Hardware Overview

Fast Track C600 Top Panel Features

Figure 1 identifies the controls, indicators on the Fast Track C600 top panel.

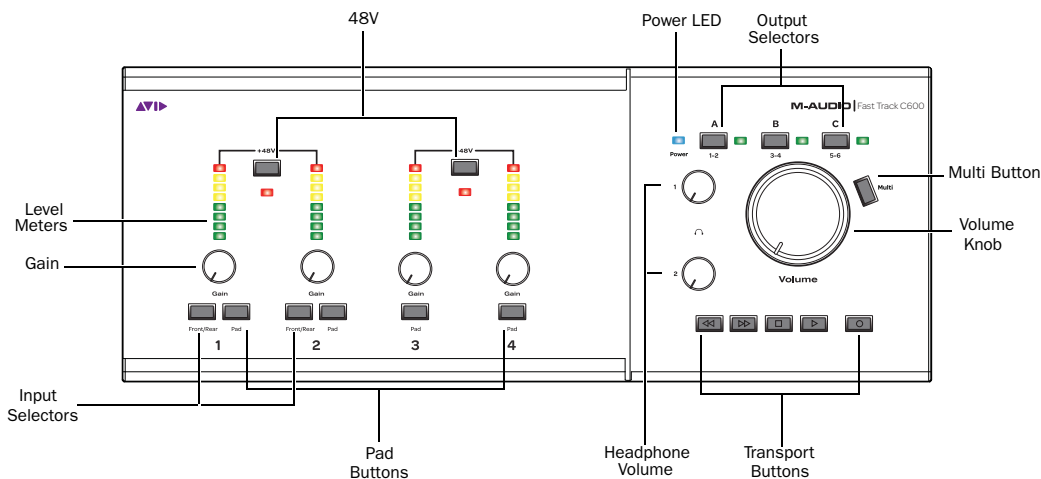

Figure 1. Fast Track C600 top panel

The Fast Track C600 top panel provides the following:

Front/Rear Input Selectors

The Input Selector button for Inputs 1 and 2 select either the front panel Instrument Inputs (TS) or rear panel Mic/Line Inputs (XLR/TRS combo) for each channel.

When these buttons are set to the “In” position, the corresponding front panel Instrument Input is active. When they are set to the “Out” position, the corresponding rear panel Mic/Line Input will be active.

Pad Button

All analog input channels offer a Pad button. If your input signal is too high or “hot” even with the Gain knob at a low setting, press that channel’s Pad button to reduce the input signal by approximately 20dB.

Gain Controls

These knobs adjust the input gain levels of their corresponding Input channels. Turn a knob clockwise to increase the gain, and counter-clockwise to decrease it.

Signal/Clip LED Meters

The 8-segment LED meters illuminate to help you set correct gain levels when recording instruments or vocals. These meters receive signals from the Fast Track C600's analog-to-digital converter and are very precise. If the red LED (at the top) illuminates, it means that your signal has overloaded (or “clipped”) the converter and that your recording may contain audible distortion. If the red LED does illuminate, decrease the input level using the channel's Gain Knob to prevent any additional clipping.

48V Switch and LED

Phantom power is activated by the switches labeled 48V on the top panel of Fast Track C600. The switch on the left controls channels 1-2, whereas the right controls channels 3-4. When a 48V button is pressed, the LED directly below it illuminates and phantom power is supplied to the corresponding XLR inputs.

About Phantom Power

Dynamic microphones (such as a Shure SM57) do not require phantom power to operate, but are not harmed by it. Most *condenser* microphones (such as M-Audio Solaris™) *do* require phantom power to operate.

A *Although phantom power can be used safely with most microphones, it is possible to damage some ribbon microphones with it. Always turn off phantom power and wait at least ten seconds before connecting or disconnecting a ribbon microphone.*

A *When Fast Track C600 is powered using the supplied 5V power adapter, all input channels are active and the interface can provide as much phantom power as required to your microphones.*

If the interface is using USB bus power, analog inputs 3/4 are disabled and Fast Track C600 can provide up to 4mA of current on channels 1 and 2, or up to 8mA if only one channel is used. This is more than sufficient for most modern microphones, as well as many vintage microphones.

If you are not sure about the phantom power requirements for your microphone, consult your microphone’s documentation or contact the manufacturer.

Power LED

The blue Power LED indicates that Fast Track C600 is receiving power from either the USB connection or included external power supply.

Output Selector Buttons

These buttons switch the pairs of back panel Outputs (A, B, and C) on and off independently. This is a useful feature if, for example, you wish to check a mix between multiple sets of speakers to ensure good “translation” of that mix on large and small speakers. Alternatively, a subwoofer can be connected to one of the output pairs and switched “in” or “out,” in order to verify how a mix sounds with or without the subwoofer.

Pressing one of these buttons switches its associated output pair on or off. The green LED to the right of each button illuminates whenever the corresponding pair of outputs is active.

Volume Knob

The Volume knob adjusts the output level of the analog line outputs on the back panel. It can be configured to control outputs 1-2, 3-4, 5-6, or any combination of these output pairs in the Control Panel.

 Refer to “Master Volume Knob” on page 21 to learn how to do this.

Multi Button

The Multi button can be programmed to emulate and execute up to eight different computer key commands or key combinations in your software, as described in Chapter 6, “The Multi Button and Transport Buttons.” Depending on your software, these can include keyboard short-

cuts used for functions such as Start/Stop Record, Toggle Marker Locations, and Save, as well as any custom keyboard shortcuts you may have set up.

 Refer to the documentation provided with your recording application for further information about the available keyboard shortcuts.

Headphone Volume

These knobs adjust the output level of the headphone outputs. Headphone output 1 always mirrors line outputs 1-2 and headphone output 2 mirrors line outputs 3-4.

 Headphone output 2 is only active when Fast Track C600 is receiving power from the external power supply. It is not available when the unit is bus-powered.

Transport Buttons

Each of these buttons can be programmed to emulate and execute a different computer key command or key combination in your software, as described in Chapter 6, “The Multi Button and Transport Buttons.” Depending on your software, these can include keyboard shortcuts used for functions such as Start/Stop Record, Toggle Marker Locations, and Save, as well as custom keyboard shortcuts you may have set up.

 Refer to the documentation provided with your recording application for further information about the available keyboard shortcuts.

Fast Track C600 Back Panel Features

Figure 2 identifies each port on the back panel of the Fast Track C600.

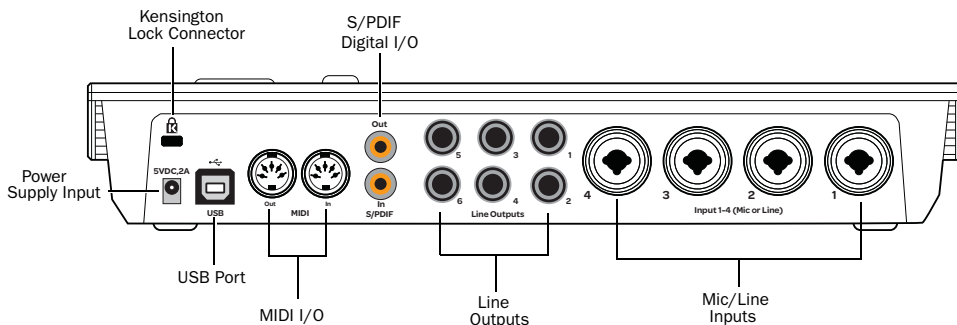

Figure 2. Fast Track C600 back panel

The Fast Track C600 back panel provides the following:

Power Supply Input

This socket is used for connecting the included 5 Volt DC (2 Amp) external power supply.

When the power supply is connected, the top panel Power LED will illuminate indicating that the interface is receiving power.

When your Fast Track C600 is receiving power from the external power supply, all of its inputs and outputs will be available.

⚠ While it is possible to power the interface through the USB cable without the power supply, please note that due to inherent power limitations of the USB bus, analog inputs 3-4, analog outputs 5-6, and headphone output 2 will not be available. These inputs and outputs are only available when the external power supply is used.

💡 When using the external power supply, you still need to use the USB connection to get audio and MIDI signals to pass between the interface and your computer.

USB Port

This port is used to connect Fast Track C600 to a USB 2.0 port on your computer using the USB cable included with your interface. This connection allows audio and MIDI signals to pass between the interface and your computer.

Fast Track C600 can be “bus powered” through the USB cable when external “wall” power is not available. This is useful in remote locations when a laptop’s battery may be the only available source of power. However, please note that analog inputs 3-4, line outputs 5-6, and headphone output 2 are not available when the interface is being bus powered. This limitation is present because the USB specification does not provide enough current to power all of the high-quality Fast Track C600 components.

MIDI I/O

The MIDI In and MIDI Out ports are standard 5-pin MIDI connectors, each providing 16 channels of MIDI input or output.

S/PDIF Digital I/O

S/PDIF is a connection protocol that lets you digitally connect Fast Track C600 to external devices that also have S/PDIF ports (such as CD players, DAT recorders, or external AD/DA converters).

S/PDIF sends and receives signals over unbalanced phono (RCA) cables at up to 24-bit, 96kHz resolution when used with Fast Track C600.



Please be sure to use 75-ohm coaxial cable for S/PDIF transfers and keep the cable length to a maximum of 10 meters.

The S/PDIF input and output channels are available in addition to the analog input and output channels. This lets you use Fast Track C600 as a 6-in/8-out audio interface.

Line Outputs

These pairs of outputs (A, B, and C) support balanced (TRS), or unbalanced (TS), 1/4-inch connections. These outputs can be connected to a mixing board or directly to a monitoring system, such as powered monitors, a stereo power amp, or another stereo destination.

⚠ *Output pair 5-6 is only active when Fast Track C600 is receiving power from the external power supply.*

Mic/Line Inputs

Each analog input channel provides combination XLR/TRS on the back panel. These balanced/unbalanced analog audio inputs support the following input levels:

- Mic (microphone) for XLR inputs
- Line (TRS) for line level signals on TRS or TS inputs

⚠ *Inputs 3 and 4 are only active when Fast Track C600 is receiving power from the external power supply.*

On the top panel, the input signal is adjusted by the Gain control for each channel.

For channels 1 and 2, the input source (back panel Mic/Line, or front panel Instrument) is chosen using the corresponding Front/Rear Input button for each channel.

Kensington® Lock Connector

This connector is compatible with standard laptop-style Kensington® security cables for theft prevention.

Fast Track C600 Front Panel Features

Figure 3 identifies each port on the front panel of the Fast Track C600.

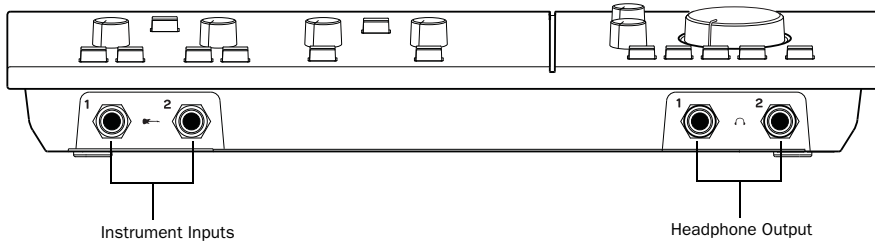

Figure 3. Fast Track C600 front panel

The Fast Track C600 front panel provides the following:

Instrument Inputs

These 1/4-inch inputs are for connecting an electric guitar, bass, or other instrument-level signal. The levels for these inputs are controlled by the corresponding Input Gain knobs on the top panel.

Headphone Outputs

Connect up to two pairs of headphones to these outputs. Headphone 1 mirrors line outputs 1 and 2, while Headphone 2 mirrors line outputs 3 and 4. The levels for these outputs are controlled by the Headphone Volume knobs on the top panel.

⚠ *Headphone output 2 is only active when Fast Track C600 is receiving power from the external power supply.*

chapter 3

Fast Track C600 Installation

This chapter covers the Fast Track C600 installation for Mac and Windows.

Installing Fast Track C600 Drivers

Mac OS X

To install the Fast Track C600 driver:

- 1 Make sure Fast Track C600 is not connected to your computer.

⚠ *If you have connected the interface to your computer, please disconnect it before proceeding to step 2.*

- 2 Download the latest Fast Track C600 driver from www.m-audio.com/drivers. If you do not have internet access, locate the installer found on the Fast Track C600 disc, and proceed to the next step.

- 3 Double-click on the installer icon and follow the on-screen instructions.

When the installation is complete, restart your computer and connect your Fast Track C600 to an available USB port on your computer.

⚠ *Fast Track C600 may not function properly if connected to a USB hub. Please connect directly to your computer's USB port whenever possible.*

A Note for Mac OS 10.6.7 Users

The Keyboard Setup Assistant will appear first time you connect Fast Track C600 to you computer. Please close the window, and *do not* click "Continue." This will not affect the performance of the interface.



Mac OS 10.6.7 - Keyboard Setup Assistant

Windows

To install the Fast Track C600 driver:

1 Make sure Fast Track C600 is not connected to your computer.

 *If you have connected the interface to your computer, please disconnect it before proceeding to step 2.*

2 Download the latest Fast Track C600 driver from www.m-audio.com/drivers. If you do not have Internet access, locate the installer found on the Fast Track C600 Drivers and Documentation disc that ships with the product, and proceed to the next step.

3 Double-click on the installer icon and follow the on-screen instructions.

When the installation is complete, restart your computer and connect your Fast Track C600 to an available USB port on your computer.

 *Fast Track C600 may not function properly if connected to a USB hub. Please connect directly to your computer's USB port whenever possible.*

 *You may be notified that the driver being installed has not passed Windows Logo Testing, or asked whether the program you wish to run is a trusted application. Click "Install" to continue the installation.*

4 Once the installation is complete and your computer has been restarted, connect your Fast Track C600 to an available USB port on your computer.

chapter 4

Hardware Connections

To hear audio recorded from Fast Track C600, you will need to connect headphones or an external sound system (such as powered monitors or a home stereo) to Fast Track C600. Sound from Fast Track C600 *cannot* be played through your computer's speakers or your computer's sound output.

 Please refer to your audio application's documentation to learn how to route signals to and from Fast Track C600

Connecting Headphones

On the front panel of the Fast Track C600 are two 1/4-inch jacks for connecting headphones. The volume level of the headphone signals are controlled by Headphone Volume knobs on the top panel.

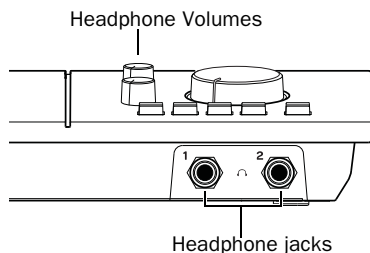

Headphone jacks on Fast Track C600 front panel

Connecting a Sound System

The Line Outputs on your Fast Track C600 are grouped in pairs that correspond to the top-panel Output Selector buttons A, B, and C.

These connections support 1/4-inch balanced TRS (Tip, Ring, Sleeve), or unbalanced TS (Tip, Sleeve) connectors. These outputs can be connected to any amplification system: powered speakers, a home stereo system, or an audio mixer.

 Home stereo systems often use RCA connectors. You can use adaptors or a cable to convert from the Line Output connectors on Fast Track C600 to the RCA connectors on your home stereo.

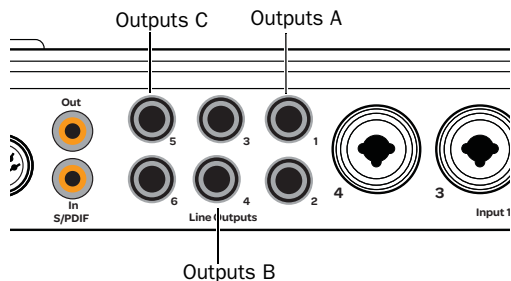

Fast Track C600 Stereo outputs A, B, and C (back panel)

Connecting Audio Inputs

This section describes the analog inputs available on Fast Track C600. For information about connecting specific audio sources, see “Connecting a Microphone” on page 12, and “Connecting Instruments to the Fast Track C600” on page 14.

Overview of Analog Inputs

Fast Track C600 inputs support microphones, guitars, keyboards, and other types of instruments. Fast Track C600 has four analog input channels, labeled “1,” “2,” “3,” and “4” on the back panel. Inputs “1” and “2” can also be accessed on the front panel when connecting instruments such as an electric guitar or bass (see “Connecting Electric Guitar or Bass” on page 14).

When recording stereo sources, use a single input pair, for example Input 1 for the left input and Input 2 for the right input.

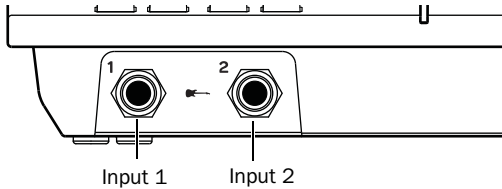

Inputs on front panel of Fast Track C600

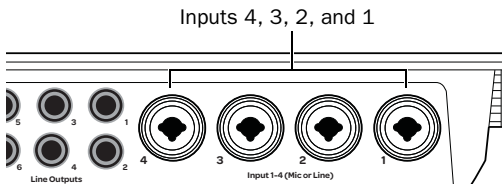

Inputs on rear panel of Fast Track C600

Each input section is located so that the hardware input jacks line up directly behind their corresponding input controls on the top panel. This makes it easier to locate channel input connections from the front. Furthermore, this layout results in the shortest, most direct signal path to ensure the best possible sound quality.

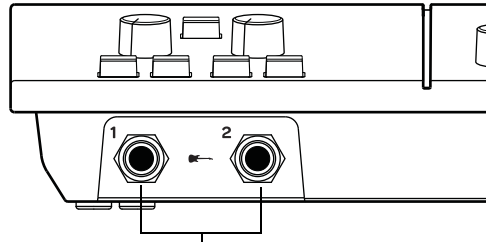

Front panel instrument inputs

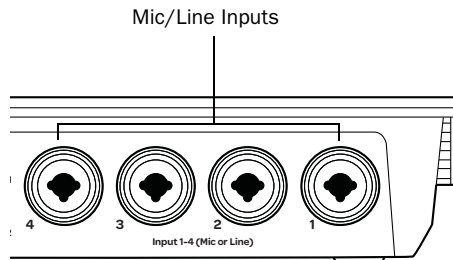

Rear panel Mic/Line inputs

Connecting a Microphone

Mic Cables and Connectors

Microphones should be connected to the back panel of Fast Track C600 using XLR cables.

The Fast Track C600 can only supply phantom power through a microphone cable with an XLR connector (the 1/4-inch TRS portion of the back-panel Combo connector does not carry phantom power regardless of how the 48V

switch is set). If you are not sure about the phantom power requirements for your microphone, refer to your microphone's documentation or contact the manufacturer.

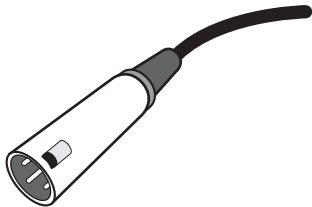

XLR connector

Phantom Power

Some microphones require power to operate. This power, called *phantom power*, is supplied either by a battery in the microphone, or through an audio interface (such as Fast Track C600) that can send power through the microphone cable.

Most *condenser* microphones (such as an M-Audio Solaris) require phantom power to operate. *Dynamic* microphones (such as a Shure SM57) do not require phantom power to operate, but are not harmed by it.

⚠ *Although phantom power can be used safely with most microphones, it is possible to damage some ribbon microphones if the phantom power is left on. Always turn off phantom power, and wait at least ten seconds before connecting a ribbon microphone.*

Using a Mic with an XLR Connector

To use a microphone that has an XLR connector:

1 Plug your microphone cable into one of the XLR Mic inputs on the back of Fast Track C600.

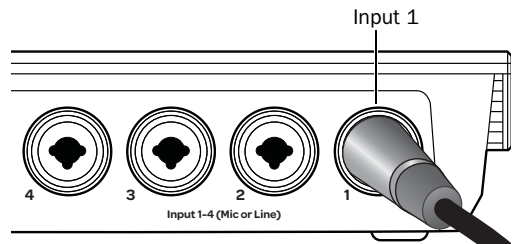

XLR connector plugged into Input 1

2 If you are using Input 1 or 2, make sure the Input Selector switch (on the top panel) is set to the “out” position. This ensures that the rear input is selected.

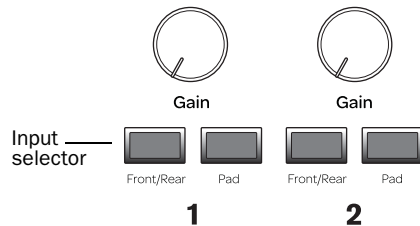

Input 1 - Input selector

3 If your microphone requires phantom power, make sure the microphone is connected, then press the Phantom Power switch (labeled 48V) on the front of the Fast Track C600 that corresponds to the input pair (1-2 or 3-4) you are using. This switch sends 48V to *both* mic inputs. The 48V LED on the front of the Fast Track C600 will light when phantom power is being supplied.

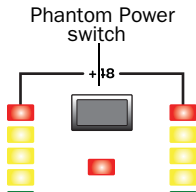

Phantom Power switch

4 On the top panel of the Fast Track C600, begin by turning the Gain knob fully counter-clockwise. As your sound source (instrument, voice, etc.) is performing at its loudest levels, turn the gain knob clockwise until the input level meters are peaking within the yellow band of LEDs. The red “Clip” LED (at the top of the meters) should not illuminate as that means your signals have overloaded the converters.

At this point, you have set optimum gain levels and can begin recording.

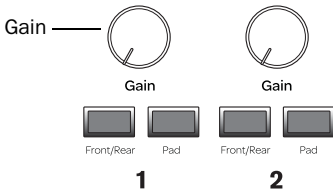

Gain knob for Input 1

5 If you are working with very loud sources and the incoming signal is too loud even at minimum gain levels (for example, when the Gain knob is turned fully counter-clockwise), engage the Pad switch. This will further reduce incoming levels by approximately 20 dB to prevent any distortion.

Connecting Instruments to the Fast Track C600

Fast Track C600 provides two input types (DI and Line) that correspond to the different signal strengths output by different types of instruments.

DI Inputs These front-panel inputs are specifically designed for instruments such as electric guitar or electric bass, which usually have a lower output level and different impedance than line-level devices.

Line Inputs Line-level devices, including electronic audio sources such as mixers, samplers, keyboards, and synthesizers should be connected to the Line inputs on the rear of the interface.

Connecting Electric Guitar or Bass

To use a guitar with Fast Track C600:

1 On the front of the Fast Track C600, plug your guitar cable into one of the Instrument inputs.

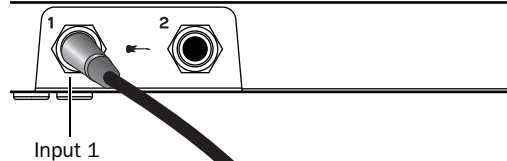

Connecting a guitar to the 1/4-inch connector

2 Ensure that the Input Selector switch (on the top panel) is set to the “In” position.

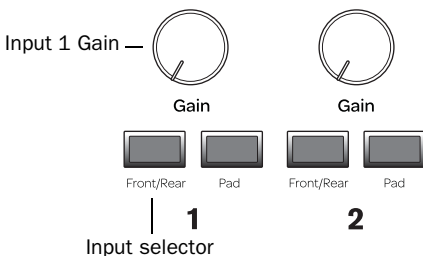

Input selector and Gain knob for Input 1

3 First, turn the Gain knob full counter-clockwise. While your guitar (or bass) is playing at its loudest levels, turn the knob clockwise until the input level meters are peaking within the yellow band of LEDs. The red “clip” LED (at the top of the meters) should not illuminate as this means your signals have overloaded the converters.

At this point, you have set optimum gain levels and can begin recording.

Connecting Keyboards and Mixers

To use a keyboard or mixer with Fast Track C600:

1 Plug your keyboard, mixer, or other audio source into one of the Inputs on the back panel of your Fast Track C600. If your source is stereo (such as a stereo keyboard or the stereo output from a mixer), choose a pair of Inputs (such as 1 and 2 or 3 and 4) and connect the left channel (often the white plug) to the odd numbered Input of the pair, and right channel (often the red plug) to the even numbered Input.

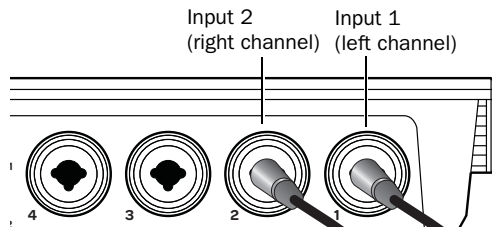

Fast Track C600 connections for line-level stereo input source

2 If you are using Inputs 1 and 2, ensure that the Input Selector switch (on the top panel) is in the “Out” position.

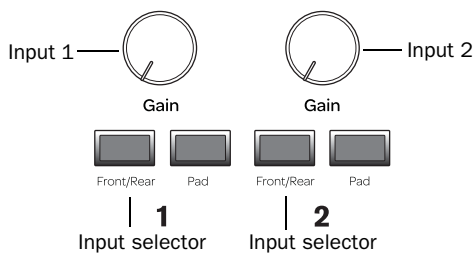

Input selector and Gain knobs for Inputs 1 and 2

3 Set your instrument’s volume to its optimal level. For example, the optimal level for most keyboards is between 80% and 100% of maximum volume.

4 On the top panel of the Fast Track C600, begin by turning the Gain knob fully counter-clockwise. As your sound source is performing at its loudest levels, turn the gain knob until the input level meters are peaking within the yellow band of LEDs. The red “Clip” LED (at the top of the meters) should not illuminate as that means your signals have overloaded the converters.

At this point, you have set optimum gain levels and can begin recording.

Digital Input and Output

Fast Track C600 provides digital inputs and outputs for S/PDIF format digital audio. These inputs and outputs can be used in conjunction with the four analog inputs and six analog outputs of Fast Track C600. This means the interface is capable of handling 6 inputs and 8 outputs simultaneously.

Connecting Digital Devices

To connect a S/PDIF device to Fast Track C600:

- 1 Be sure to use 75-ohm coaxial cables with male RCA connectors on both ends.
- 2 To send a digital signal into the Fast Track C600, connect the device's S/PDIF output to the Fast Track's S/PDIF input port. To send a digital signal from the Fast Track C600 to an external device, connect the Fast Track C600 S/PDIF output to the device's S/PDIF input.

Using S/PDIF Input

To configure Fast Track C600 to record from a S/PDIF device:

- 1 Open the Fast Track C600 Control Panel and click the Setup button in the upper right section of the window.
- 2 When the Setup dialog opens, select S/PDIF from the Clock Source pop-up menu on the General Setting page, and then click the Close button in the lower right of the Setup window.
- 3 On the recording track in your software, select the appropriate stereo or mono S/PDIF source from the track Input selector.

It should now be possible to record incoming S/PDIF signals with your audio application.

 Recording and playing back through the S/PDIF ports may vary depending on your audio software. Please refer to your software's documentation to learn more about how to do this.

MIDI Connections

The two MIDI ports on Fast Track C600 let you take advantage of MIDI features within your recording application, including recording and editing MIDI tracks.

To connect your MIDI device to Fast Track C600:

- 1 Connect a standard 5-pin MIDI cable from the MIDI Out port of your device to the MIDI In port on the back of Fast Track C600.
- 2 Connect another MIDI cable from the MIDI In port of your device to the MIDI Out port on the back of Fast Track C600.

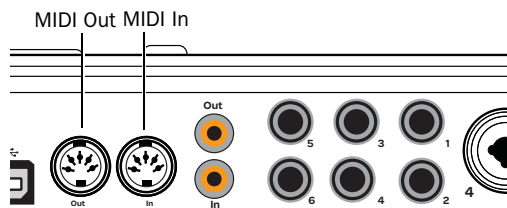

MIDI connections to Fast Track C600

Monitoring MIDI Instruments with Fast Track C600

If you have a MIDI instrument that has analog outputs, you can connect its outputs to a pair of analog inputs of Fast Track C600 to monitor or record the instrument.

To connect your MIDI instrument for monitoring in your recording software:

- Connect the MIDI instrument's audio outputs to a pair of line (TRS) inputs on your Fast Track C600. Connect the left channel to the odd numbered Input of the pair, and right channel to the even numbered Input.

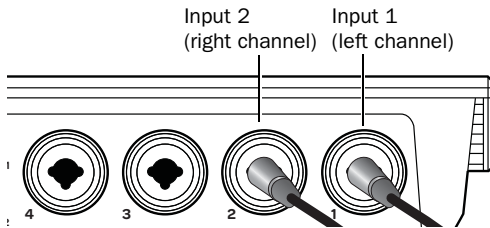

Fast Track C600 connections for line-level stereo input source

chapter 5

The Driver Control Panel

Several features of Fast Track C600 can be accessed directly from the Fast Track C600 top panel, such as input gain, phantom power, and output levels. But there are many additional parameters that cannot be accessed from the top panel. These additional features are available to you using the included Driver Control Panel application.

To open the Driver Control Panel

- On Mac, launch System Preferences (Apple menu > System Preferences), then click Fast Track C600. (You can also open the Driver Control Panel from the Applications menu.)

– or –

- On Windows, choose Start > Control Panel > Fast Track C600.

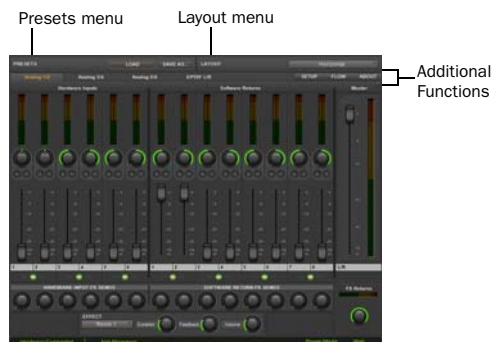

Fast Track C600 Driver Control Panel (Horizontal view shown)

Presets

The Preset section lets you load and save Fast Track C600 Settings files, which contain all settings of the Fast Track C600 Driver Control Panel. This is useful if you'd like to save various configurations so that you do not have to manually reconfigure your system each time you work on a different type of project.

Load Button

The Load Button opens a file browser that lets you load a previously saved Settings file.

Save as...

The Save as button opens a file browser that lets you save the current settings of the Driver Control Panel to a Settings file.

Layouts

The Layout drop-down menu lets you choose what information you would like the Driver Control Panel to show, and how you would like that information to be displayed. There are four layouts to select from:

Horizontal

The Horizontal layout is the default layout. It shows all knobs, faders, meters and buttons in a layout similar to that of a mixing console. The Horizontal layout is used for all the screen captures in this chapter.

Horizontal (Meters Only)

The Meters Only layout emphasizes pre-fader hardware input and software return metering, but does not provide access to the stereo mixers.



*Fast Track C600 Driver Control Panel
(Horizontal (Meters only) shown)*

Vertical



*Fast Track C600 Driver Control Panel
(Vertical shown)*

The Vertical layout provides access to all controls and meters in a vertical window. The Vertical layout was designed for compact operation, which is convenient if you want to run it alongside your audio application, since it uses far less screen real estate, but provides full functionality.

Vertical (Meters Only)

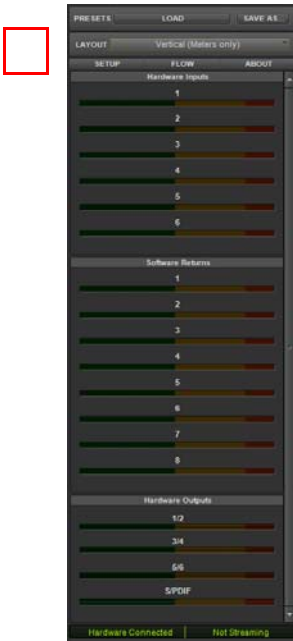

Fast Track C600 Driver Control Panel
(Vertical (Meters only) shown)

The Meters Only layout emphasizes pre-fader hardware input and software return metering, but does not provide access to the stereo mixers

Additional Functions

Fast Track C600 also features a variety of functions accessed by clicking buttons located in the upper-right area of the Control Panel:

- Setup
- Flow
- About

Setup

Setup is where you define the hardware settings of the Fast Track C600. For example, you can set buffer size, sample rate, and clock source. Clicking the Multi-Button Settings button lets you configure the Multi Button as described in Chapter 6, “The Multi Button and Transport Buttons.”

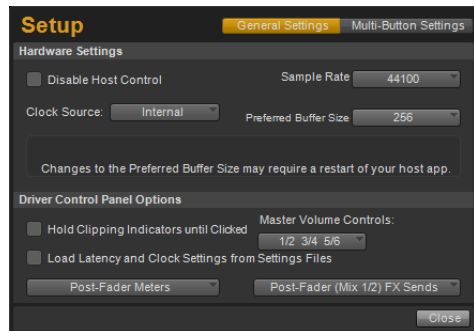

Setup pop-up menu

In the Setup window, the options are grouped in the following categories:

Hardware Settings

The parameters in this section of the Control Panel govern the operation of the interface.

Master Volume Knob

These check boxes (Output “1-2”, “3-4” and “5-6”) determine which analog output pair(s) will be affected by the Master Volume knob on the top panel of the interface: If a box is checked, the volume level of its corresponding outputs will be controlled by the Master Volume knob; if a box is left unchecked, the outputs will play at full volume regardless of the position of the Master Volume knob.

This feature gives Fast Track C600 a great deal of flexibility in how it can be used. For example, studios with multiple sets of studio monitors may wish to connect one set of speakers to outputs 1-2 and a second or even a third set of speakers (or a subwoofer) to outputs 3-4, or 5-6. This allows users to easily switch between the sets of speakers using the output selector buttons on the top panel while still being able to control all of the speakers with one volume knob. In this case “Output 1-2,” “Output 3-4,” and “Output 5-6” if all are checked.

This functionality is also very useful when working in multi-channel “surround” formats, because you can use the Master Volume knob to simultaneously set the level of all speakers that are connected to the outputs of Fast Track C600. Again, “Output 1-2,” “Output 3-4,” and “Output 5-6” should be checked in this instance.

On the other hand, for example, if line outputs 1-2 are connected to speakers but outputs 3-4 and 5-6 are connected to external devices (such as effects processors, a mixing console, or another device), you may want to control the level of outputs 1-2 with the Master Volume Knob while leaving outputs 3-4 and 5-6 playing at full

volume regardless of how the Master Volume Knob is set. This can be done by checking “Output 1-2” while leaving the “Output 3-4” and “Output 5-6” boxes unchecked. If you are leaving any output unchecked, please be sure to heed the warning below.

Finally, some users with external mixing consoles or dedicated speaker management systems may wish to have the outputs always play at full volume, regardless of how the master volume is set. In this case, all of the Output boxes should be left unchecked. Again, if you are leaving these outputs unchecked, please be sure to heed the warning below.

 *Unchecking one of the Master Volume Knob boxes allows its corresponding outputs to play at full volume (i.e., without any attenuation). This may result in very loud signals being sent to your speakers, headphone amplifiers, or other equipment. Be mindful of your outgoing levels anytime you uncheck one of these boxes to avoid potentially damaging your equipment (or hearing). If you wish to leave these boxes unchecked in order to allow full, un-attenuated signals to play through the interface, it is strongly recommended that you have an external provision for controlling your levels (such as an external mixer).*

Disable Host Control

Certain recording applications are able to control the Fast Track C600 low-latency monitor mixer through the ASIO Direct Monitoring (ADM) standard. This is a convenient feature because all low latency monitoring is handled through your music application's mixer and there is no need to manually control settings on the Monitor Mixer in the Fast Track C600 Control Panel.

Launching a supported music application when this box is left unchecked, lets the software take control of the Control Panel's first stereo mixer. If you would prefer to maintain full manual control of the Fast Track C600 monitor mixer, make sure that this box is checked.

Clock Source

This setting determines the clock source to which Fast Track C600 is synchronized.

Internal If you are using Fast Track C600 by itself (i.e., without other digital devices or an external clock), select the Internal option for the interface to work properly.

S/PDIF If you have connected a S/PDIF device to your Fast Track C600 and would like to use that device as the master clock source, select the S/PDIF option. This will make Fast Track C600 clock to the external device's clock.



When S/PDIF is selected as the clock source, the Sample Rate drop-down menu will be greyed out while displaying the incoming sample rate.

If S/PDIF is set as the clock source and Fast Track C600 is unable to detect, or lock to the external clock source, a message will appear beneath the Clock Source drop-down menu saying: "External clock not detected, Sample Rate fixed at 48kHz."

Sample Rate

This drop-down menu sets the sample rate of Fast Track C600. Note that when using the interface with an ASIO or CoreAudio application, the sample rate can also be determined by your audio application. This parameter may not be editable from within the Fast Track C600 Control Panel if your audio application is running. In this case, any changes to the sample rate must

be made through the audio application itself. If the application does not provide a way to set the sample rate, quit the application, then change the sample rate through the Fast Track C600 Control Panel.



In Windows Vista, when using the Fast Track C600 WDM/MME (i.e., non-ASIO) drivers, the sample rate of the interface (and your audio software) is always determined by this drop-down menu. Your selection in this menu is the only item that will appear in your audio application. For example, if you select "44.1kHz" in this menu, your audio application's control panel will only display "44.1kHz" and you will not be able to select any other rates from within the application.

When the sample rate is locked to an external digital clock source (S/PDIF is selected as the clock source), the Sample Rate drop-down menu will be greyed out while displaying the incoming sample rate.

Buffer Size (Windows only)

This menu sets the size of the input and output buffers on Fast Track C600.

Buffers are used to help keep audio hardware and software running smoothly by processing audio in groups of samples rather than one sample at a time. Due to variations between computer hardware and software, it is impossible to recommend a single optimum setting for all systems. It may be necessary to experiment with various settings until you find the best buffer size for your system.

The goal of setting a buffer size is to reduce it as much as possible without hearing any clicks, pops, or other glitches. If the buffer size is too small, the computer will not be able to make all the required audio calculations in time, and you

will hear pops, clicks, and stuttering in your audio streams. On the other hand, if the buffer size is set too high, your computer will process audio without incident, but your software will feel sluggish and unresponsive.

To find your system's optimum buffer size setting, begin with a high setting and gradually reduce the size until you begin to hear clicks, pops, or other audible glitches in your audio. Then, raise the buffer size setting until these glitches disappear. You may need to stop playing audio any time you change this setting and certain applications will require you to re-launch the program before the new buffer size settings become active.

 *This menu only appears on Windows systems. Most Mac OS X applications allow to change the buffer size from within the audio application itself. Please see your audio application's user guide to learn how to change this setting.*

Multi Button Settings

Fast Track C600 has a Multi button, and five assignable Transport buttons which can be programmed as described in Chapter 6, "The Multi Button and Transport Buttons."

Driver Control Panel Options

Hold Clipping Indicators until Clicked

The top section of the meters (or right section for horizontal meters) of the Driver Control Panel feature a red clipping indicator. When this option is selected, the clipping indicators will remain lit until they are clicked.

Load Clock Settings from Settings Files

When this option is selected, the clock source and buffer settings are recalled when loading a settings file. By leaving this box unchecked, you can load custom settings files with different low-latency mixer configurations, without inadvertently changing the buffer size or clock source settings of the device.

Post-Fader Meters

When this option is selected, the meters will display levels *after* the channel fader. This means fader positions will affect what you are seeing on the meters.

Pre-Fader Meters

When this option is selected, the meters display the level of a signal *before* it passes the fader. This allows signal levels to be displayed regardless of the fader positions within the stereo mix (in other words, a fader can be all the way down and no sound will be heard from the mixer's output, but you can still see if there is any activity on that input).

FX Sends Mode

Pre-Fader FX Sends

When Pre-Fader FX Sends is selected, the full audio signal will be sent to the FX Sends, regardless of the position of the Channel Faders of stereo mix 1–2.

Post-Fader (Mix 1/2) FX Sends

When Post-Fader (Mix 1/2) is selected, the audio signal level being sent to the FX Sends will be affected by the position of the Channel Faders of Stereo Mix 1.

Flow

Clicking the Flow button opens a display showing the signal flow from the inputs to the outputs of Fast Track C600. This is a useful reference for understanding the path of an audio signal flowing through Fast Track C600.

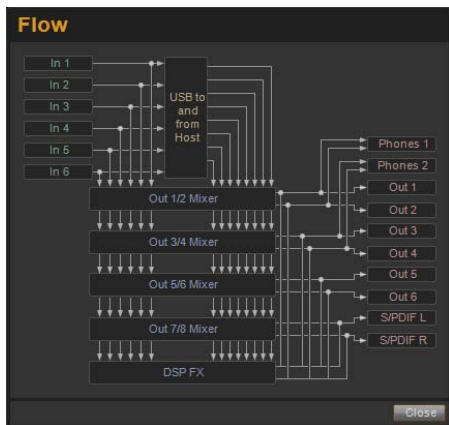

About

The About pop-up menu allows you to view the firmware version of the Fast Track C600 hardware, and provides convenient web links to product documentation, updates, support, FAQ, and registration.

⚠ *Your computer must be connected to the Internet in order for these links to work.*

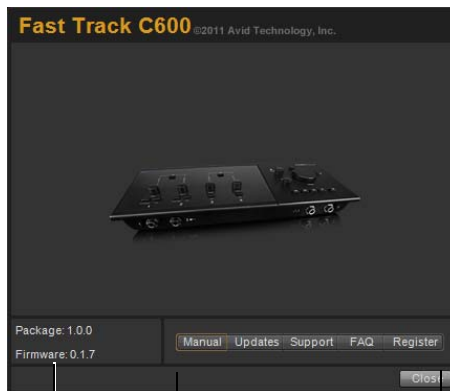

Firmware and driver information

Web links

Viewing Firmware and Installer Information

In this section, you can view the firmware version of the Fast Track C600 hardware, and the package version of the Fast Track C600 driver installer.

Accessing the Web Links

Along the bottom-right of the Driver Control Panel you can easily access helpful online resources on our website (www.m-audio.com) by clicking on the following pop-up menus:

- Manual
- Updates
- Support
- FAQ
- Register

Monitor Mixes

The monitor mixer allows you to create four different stereo mixes from 14 input sources consisting of any of the hardware inputs (4 analog and 2 digital inputs) and software returns (8 software returns). This allows you to set up near-zero latency cue mixes in which the performers hear a “customized” mix while recording.

It is important to note that any changes made to the monitor mix will only affect what is audible from the mixer’s outputs—the monitor mix does not affect the signals that are sent to your software for recording. For example, if you are recording a vocalist and they tell you to turn up the vocal track so they can hear themselves better, you can increase the vocalist’s microphone channel in the monitor mix. This will make the vocal part louder in the vocalist’s headphones, but it will still be recorded into your software at the volume determined by the top panel Gain Knob.

The monitor mixer is set up like a standard mixing console: There are 14 channels (6 hardware inputs and 8 software returns), each with its own volume fader, pan and aux send knobs, solo, and mute buttons, as well as a master output section with its own fader.

A pair of channels can be linked together by clicking the link icon between the two channels. Linking channels allows you to adjust mute, solo, and fader settings simultaneously by modifying parameters on either one of the linked channels. However, linking two channels will not have any effect on their Pan controls, which are always made on a per-channel basis.

The monitor mixer features high-resolution meters to show input channel levels (directly above each channel) and main mixer output levels (at the top right of the mixer). The pre/post fader metering operation can be set from the Settings Tab of the Control Panel. The clip indicators can be reset by clicking on the meter itself.

Keep in mind that setting or adjusting a monitor mixer will not affect the signal that is recorded into your software. For example, you’ll still be able to record a channel while its corresponding stereo mix channel is muted. You won’t hear the part through the monitor mixer as it is being recorded, but it will still record into your software and play back properly.

Using the Monitor Mixer

The Monitor Mixer is located in the main view of the Driver Control Panel and is divided into four main sections:

- Hardware Inputs
- Software Returns
- Effects
- Master

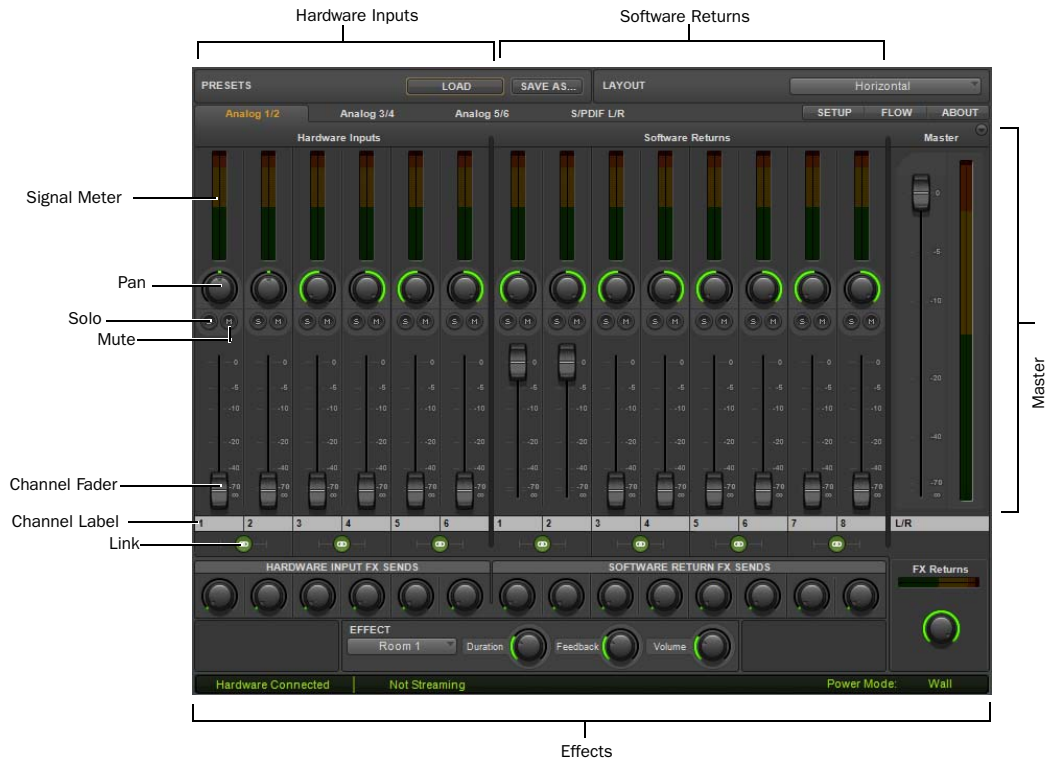

Hardware Inputs

The Hardware Inputs section is where the Mic/Line and Instrument inputs are monitored, as well as the S/PDIF input of Fast Track C600. Hardware Inputs 1–4 are the analog inputs, and Hardware Inputs 5–6 are the S/PDIF input L/R.

Software Returns

The Software Returns section is where the audio coming back from your audio application is monitored. Software Returns 1 and 2 will be the default stereo output from the software.

Pan

The Pan knobs control the position of a channel's audio signal in the stereo image of the monitor mix (double-click the knob to return pan to center).

Solo

Each Solo button lets audio be monitored for the channel of which it is a part, while simultaneously muting all other Hardware Input channels and Software Returns (except for those that also have their Solo buttons activated).

Mute

The Mute buttons are used to individually turn off audio monitoring for each channel in the monitor mix.

Channel Faders

The Channel Faders control the monitoring volume level of each channel in the monitor mix.

Channel Labels

By default, the Channel Labels show the input name of each channel, except for the Master fader pair (which is labeled L/R by default).

Clicking on a Channel Label gives you a cursor, allowing you to type in your own custom channel name (such as "guitar," "vocals," etc.).

The Channel Labels also display the signal level (in dB) while a fader is being adjusted.

Link

The Link buttons connect stereo pairs of knobs or faders (and also links the corresponding FX Send knobs), so that adjusting either channel (left/right) adjusts the other side identically.



 *Pan controls are unaffected by linking two channels.*

Effects

The Effects section is where you set up "send-and-return" configurations, and select the effects that you apply to the Hardware Inputs and/or Software Returns.

Hardware Input FX Sends

FX Sends are shared by all Stereo Mixes, unless "Post-Fader Stereo Mix 1" is chosen in the Setup pop-up menu.

Software Return FX Sends

FX Sends are shared by all Stereo Mixes, unless "Post-Fader Stereo Mix 1" is chosen in the Setup pop-up menu.

FX Returns

These knobs control how much of the Effect audio output will be mixed in with the monitor signal Master L/R outputs. Unlike sends, FX Returns are individually adjustable for each monitor mix.

The Clip LED will show clipping if the input to the FX is clipping and if the output is clipping.

Effect

The Effect drop-down menu is used to select the effect to be applied to the Hardware Inputs and/or Software Returns. There are eight available reverb types: Three room reverbs, two hall reverbs, a plate reverb, delay, and an echo. These effects can be customized by using the following three controls:

Duration This knob controls decay time (for the reverbs) or delay time (for delay and echo).

Feedback This knob controls the number of repeats for the delay and echo effects. It does not affect the reverbs.

Volume This knob controls the effects output level being sent to the FX Returns.

Master

The Master section is for monitoring the main mixer output.

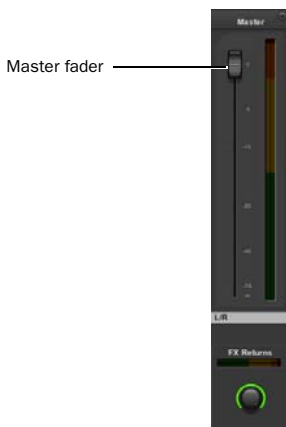

Master Fader Adjusts the overall level of the monitor mix.

Master Meters Provides a visual representation of the audio signal being fed to the associated hardware output pair.

Status Indicators

Along the bottom-left of the Driver Control Panel are the following status indicators:

Hardware Connected

This tells you the status of the hardware; if a properly installed, powered-on Fast Track C600 is connected to the computer.

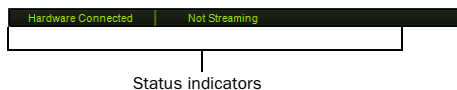

Streaming

This indicates if audio from a Digital Audio Workstation or a media player (such as Windows Media Player) is currently streaming audio to the Fast Track C600.



chapter 6

The Multi Button and Transport Buttons

Overview

The assignable Multi and Transport Control buttons on your Fast Track C600 can be programmed to emulate “ASCII” computer key commands (or key combinations) in your software. This is useful because you can perform common tasks with a single button instead of using on-screen menu commands or having to remember keyboard shortcuts.

Multi Button

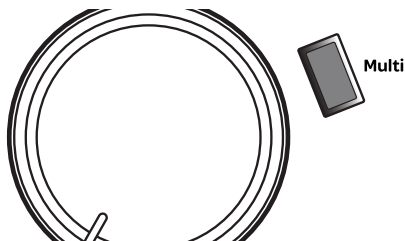

Fast Track C600 Multi button

The Multi button can be programmed to perform a sequence of up to eight different keyboard shortcuts.

Depending on your software, these shortcuts can include functions such as:

- Play
- Stop
- Record
- Toggle Marker Locations

- Create New Track
- Save
- Custom keyboard shortcuts you may have set up.

 Refer to the documentation provided with your recording application for further information about the available keyboard shortcuts.

The Multi button supports up to eight “Steps.” This means you can program up to eight different key commands which are carried out step-by-step each time the Multi button is pressed. See “Configuring the Multi Button (Building a Macro)” on page 33.

Transport Buttons



Fast Track C600 Transport button

Unlike the Multi button, the Transport Control buttons support a single “Step.”

Typically, these buttons will be assigned to keyboard shortcuts that correspond to their labeled functions (Rewind, Forward, Stop, Play, and Record). However, please keep in mind that these

buttons are freely programmable, and can be assigned to control other functions, such as zoom in or zoom out, set locator, return to zero, etc. See “Configuring the Transport Buttons” on page 34.

Multi and Transport Control Button Settings

To configure the Multi button or Transport buttons, start by launching the Driver Control Panel. Next, click the Setup button in the upper right of the Control Panel window, and click the Multi-Button Settings button.

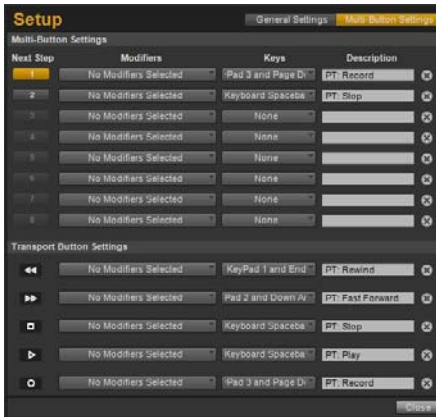

Multi-Button Settings Dialog

The Multi-Button Settings dialog offers the following buttons, dropdown menus, and options which are used for configuring a the Multi and Transport Control buttons.

Next Step

The upper section of the window contains a column of Step buttons. Each button represents one of the 8 available steps that can be configured within a macro. Any unused steps will be ignored by the macro and it will jump to the next non-empty step. After the eighth (or last used) step, the macro returns to Step 1 so that it can be performed again.

Transport Control Icons

These icons, located below the Step buttons, represent the Transport Control buttons on the top panel the interface.

Modifiers

There are 8 drop down menus corresponding to each available Step of a Multi button macro. These contain options for any modifier keys which maybe required when executing a key command or keyboard shortcut.

For Mac these are:

- Control
- Command
- Option
- Shift

For Windows these are:

- Control
- Shift
- Alt
- Win (Windows Logo key)

Keys

These drop down menus contain options for the alpha-numeric and symbol keys that can be assigned to the Multi or Transport Control button.

In the case of the save command this would be the letter “S” combined with the “Command” (Mac) or “Control” (Windows) modifier.

Description

The grey Scribble Strips are provided so that you can label each Step with a description of the function performed.

X Buttons

You can clear or deleted a Step by clicking the red “X” at the end of the row. When this button is clicked, the Modifiers parameter is set to “No Modifiers Selected” and Keys parameter is set to “None.”

About Multi Button Macros

A macro can be described as a combination of actions or functions used in performing a particular task. In the case of music creation, and example of one of the most common tasks involves recording a track, rewinding the song, and playing back what you've recorded.

The Driver Control Panel lets you assign the Multi button to a corresponding key command for each Step of the task, such that each Step is performed as the button is repeatedly pressed. For example, the first time the Multi button is

pressed can start the recording (Step 1). The second press can stop the recording, while the third and fourth time you press the button can return the playhead to the beginning of the song, and start playback respectively. This would be considered a macro of four Steps, using four successive presses of the Multi button. Pressing the Multi button again takes you back to Step 1, and lets you repeat the sequence again.

The following table shows examples of key commands from three of the various qualified recording applications, however you should refer to your software documentation for more infor-

Function	Pro Tools	Logic	Cubase
Start Record	Command+ Spacebar (Mac) Ctrl+ Spacebar (Windows)	* (Asterisk Key - Numeric Keypad)	*(Asterisk Key - Numeric Keypad)
Stop or Stop Record	Spacebar	0 (Numeric Keypad)	0 (Numeric Keypad)
Save	Command+ S (Mac) Ctrl+ S (Windows)	Command+ S	Command+ S (Mac) Ctrl+ S (Windows)
Go to Beginning or Return to Zero	Return (Mac) Enter (Windows)	Return	“.” (Numeric Keypad)
Play	Spacebar	Enter (Numeric Keypad)	Spacebar

Configuring the Multi Button (Building a Macro)

Once you have decided what task you want the Multi button to perform, and which keyboard shortcut or collection of shortcuts the button will need to emulate, you can set up the configuration as described below.

To configure the Multi button:

1 Locate the keyboard shortcut used for a function in your software.

For this example, you want to configure the Multi button to activate a function within your software, and the keyboard shortcut is Command+ Spacebar (Mac) or Ctrl+ Spacebar (Windows).

 *Refer to your software documentation for more information about available default keyboard shortcuts, and creating custom shortcuts.*

2 Click the Step 1 button.

3 Choose the required modifier key from the Modifiers drop down menu for the Step. For this example, you will need to select Command (Mac) or Control (Windows).

 *This step is not necessary if the keyboard shortcut does not require a modifier key.*

4 From the Keys drop down menu, choose the “main” key used in the shortcut. For this example, you would need to select “Keyboard Spacebar” from the drop down menu.

5 Label the Step with a description by entering text in the Scribble Strip, such as “Record” or “Start Record.”

6 Repeat steps 1 through 5 of these instructions if you want to build a macro using as many of the remaining 7 Step buttons as required.

For example you could use Step buttons 2, 3, 4, and 5 to configure the Multi button to perform the Stop (or Stop Record), Save, Go to Beginning (Return to Zero), and Play functions respectively, within your software.

7 Save the newly configured Multi button assignment by clicking the Save As button at the top of the main control panel window.

If you have only set up one Multi button assignment or Step, the button will perform that function each time it is pressed. In the case of this example, it will activate the record button in the transport window of your software, if it was the only Step in the sequence (i.e., all other macro Steps have been cleared).

On the other hand, if you have made additional assignments, and built a macro as described in step 6 of these instructions using Step buttons 2, 3, 4, and 5, the Multi button will perform each of the five functions in the order shown in the table below, before jumping back to Step 1.

Macro Step	Macro Function
1	Start Record
2	Stop or Stop Record
3	Save
4	Go to Beginning or Return to Zero
5	Play

In other words, your software will start recording on a record enabled track the first time you press the Multi button. Once you have finish recording, pressing the button again will stop the

recording. The third time, saves your project. The fourth time returns the song to bar 1, and the fifth time you press the Multi button will begin playback.

⚠ *If you have configured the Multi button as described above, make sure you disengage the track Record Enable button once you have finished recording. Once the Multi button has performed Step 5 of the Macro, it will jump back to Step 1 and execute the Record command the next time it is pressed.*

Configuring the Transport Buttons



Fast Track C600 Transport button

Each Transport button can be assigned to any single key command or keyboard shortcut as described below.

To configure a Transport Control button:

1 Decide which Transport button you would like to assign to a keyboard shortcut in your software (such as the Record button), and locate the corresponding keyboard shortcut in your software.

Let's say we want to configure the Record button on the interface to activate a function in an application where the keyboard shortcut is Command+ Spacebar (Mac) or Ctrl+ Spacebar (Windows).

💡 *Refer to your software documentation for more information about available default keyboard shortcuts, and creating custom shortcuts.*

2 Go to the row labeled with the Transport button icon you want to assign (in this case the Record button), and choose the required modifier key from the Modifiers drop down menu. For this example, you will need to select Command (Mac) or Control (Windows).

💡 *This step is not necessary if the keyboard shortcut does not require a modifier key.*

3 From the Keys drop down menu, choose the "main" key used in the shortcut. For this example, you would need to select "Keyboard Spacebar" from the drop down menu.

4 Label the Step with a description by entering text in the Scribble Strip, such as "Record" or "Start Record."

5 Repeat steps 1 through 4 of these instructions to assign the remaining Transport buttons to other functions.

6 Save the newly configured Transport button assignments by clicking the Save As button at the top of the main control panel window.

chapter 7

Recording with Fast Track C600

This chapter covers basic workflows for recording audio and virtual instrument tracks with your Fast Track C600.

It is assumed that your interface has been properly installed and connected as described in Chapter 3, “Fast Track C600 Installation”, and Chapter 4, “Hardware Connections.”



This chapter covers the general concepts for recording audio and virtual instrument and cannot cover and cannot provide specific information for every music application. Please refer to your software’s documentation for information about application specific operations, such as creating or record enabling (record arming) a track.

Recording Audio Tracks

If you have configured the Multi button as described in “Configuring the Multi Button (Building a Macro)” on page 33, you will also be able to use this functionality when following the workflows in this chapter.

Furthermore, if you have programmed the Transport buttons to perform their usual functions as describe in “Configuring the Transport Buttons” on page 34, you can use them at the appropriate points in the procedure.

To record an audio track:

- 1 Make sure the Input Gain knobs are turned all the way down (counter clockwise), on the top panel.
- 2 Use the Input Selector buttons to select the front or rear inputs based on the type of signal your are recording:
 - If you are recording an electric guitar or bass, make sure the front input is selected (the Input Selector switch should be set to the “In” position) for the input channel you want to use (either Input 1 or Input 2).
 - If you are recording a stereo keyboard on Inputs 1 and 2, use the Input selector buttons to select the rear inputs (the Input Selector switch should be set to the “Out” position) for both Input 1 and Input 2.
 - If you have connected a microphone to Input 1 or 2, make sure the rear inputs are selected (i.e. the Input Selector switch is in the “Out” position).
- 3 Connect your signal source:
 - For electric guitar or bass, plug your guitar cable into the front panel Input for the channel you had chosen in step 2.

- For a stereo keyboard, plug the cable coming from the left output of your instrument to the Mic/Line input connector for channel 1 on the back panel of Fast Track C600, and the right output of your keyboard to the Mic/Line input connector for channel 2.
- Connect your microphone to the Mic/Line input for the channel(s) you had chosen in step two.

If your microphone requires phantom power, make sure the microphone is connected, then press the corresponding Phantom Power switch (labeled 48V) for the Input channel you microphone is connected to. Each switch sends 48V to both mic inputs for its respective input pair. The corresponding 48V LED on the front of the Fast Track C600 will light when phantom power is being supplied.

⚠ *Although phantom power can be used safely with most microphones, some ribbon microphones may be damaged if phantom power is applied to them. Always turn off phantom power, and wait at least ten seconds before connecting a ribbon microphone.*

Refer to the documentation for your microphone for more information about its power requirements.

4 Sing, or play your instrument at the loudest level you expect to reach during your recording while slowly turn the appropriate gain knob(s) clockwise, until the input level meters are peaking within the yellow band of LEDs. The red “Clip” LED (at the top of the meters) should not illuminate as that means your signals have overloaded the converters.

At this point, you have set optimum gain levels and can begin recording.

5 Create an audio track in your recording software. You will need to use a mono audio track for instruments or microphones, or a stereo track for stereo sources such as a keyboard or mixer.

6 Select the appropriate input from the Input selection options for the track.

If you are using Input 1 on your Fast Track C600, then you should select Input 1 for the track in your software.

7 Press the record enable button for that channel.



Refer to your software documentation for information about creating, record enabling (record arming) track, and track input selection.

⚠ *Steps 8 through 12 will only work if you have configured the Multi button as described in “Configuring the Multi Button (Building a Macro)” on page 33.*

8 Press the Multi button on the top panel of your Fast Track C600 to begin recording.

If you have assigned the Record button on your interface to the record function in your software, pressing it will start the recording.

9 When you have finished, press the Multi button to stop recording.

Press the Stop button on your interface, if you have assigned it to this function.

10 Press the Multi button a third time to save your work.

11 Press the Multi button twice more to go back to bar 1, and play back what you’ve recorded.

Recording Instrument Tracks

This section shows you how to record a software or virtual instrument track in your software.

If you have configured the Multi button as described in “Configuring the Multi Button (Building a Macro)” on page 33, you will also be able to use this functionality when following the workflows in this chapter.

Furthermore, if you have programmed the Transport buttons to perform their usual functions as describe in “Configuring the Transport Buttons” on page 34, you can use them at the appropriate points in the procedure.

To record an instrument track:

1 If you are using a MIDI controller, make sure you have made the correct MIDI connections as described in “MIDI Connections” on page 16.

If you are using a USB-based MIDI controller such as an M-Audio Axiom® or Oxygen keyboard from Avid, make sure you have properly installed and connected the device as described in the User Guide for that product.

 *USB-based products send and receive MIDI signals through the USB cable and do not need to be connected to MIDI ports of Fast Track C600.*

2 Create a new Instrument (or MIDI) track in your recording software, or choose an existing track to which you want to record.

3 Load a software instrument onto the track.

4 Press the record enable button for that track.



Refer to your software documentation for more detailed information about creating a virtual or software instrument track, how to load an instrument, and record enabling (record arming) the track.



Steps 5 through 8 will only work if you have configured the Multi button as described in “Configuring the Multi Button (Building a Macro)” on page 33.

5 Press the Multi button on the top panel of your Fast Track C600 to begin recording.

If you have assigned the Record button on your interface to the record function in your software, pressing it will start the recording.

6 When you have finished, press the Multi button to stop recording.

Press the Stop button on your interface, if you have assigned it to this function.

7 Press the Multi button a third time to save your work.

8 Press the Multi button twice more to go back to bar 1 and play back what you’ve recorded.

Troubleshooting

Fast Track C600 has been designed and tested under a wide range of systems and operating conditions to give you high performance and professional quality audio. However, there is a virtually limitless number of operating scenarios that could affect your system's performance. Although this chapter cannot cover all issues you may encounter, it does offer some suggestions for dealing with common problems.

As a general rule, we recommend that you avoid connecting too many devices via USB. The USB bus is a dependable protocol that is ideally suited for digital audio. Nevertheless, it is important to remember that audio and multimedia streaming can place considerable demands on your processor and the USB bus.

Check Your Connections

If you are having trouble getting audio in or out of your Fast Track C600, check the following:

- ◆ Make sure the device is connected via USB at both ends, and that the interface is receiving sufficient bus power (the blue Power LED on Fast Track C600 should be illuminated).
 - ◆ Make sure your music software is receiving audio signal. If you find that your recording application is not receiving a signal:
- Check your connections and cables to make sure everything is plugged in correctly.
 - Try using a different USB cable or USB port on the host computer.
 - Check that you have the correct input selected using the Input Selector button located on the top panel of the interface.
 - Check the input level meters for each analog input for each channel to see if an input signal is present.
 - If you are using condenser microphones that requires phantom power, make sure the Phantom Power switch associated with your microphone's input is active, and that the corresponding Phantom Power LED (48V) is illuminated on the front panel.



For more troubleshooting tips, visit the Knowledge Base at www.m-audio.com/faq.

Check the Fast Track C600 Drivers

- ◆ While it is technically possible to use your Fast Track C600 as a class-compliant interface (using the drivers already built into the computer's operating system), we advise against this, as it does not provide the best performance or complete access to all of the product's features (such as monitor mixers or Control Panel). We suggest that you download and install the latest drivers from the M-Audio website at www.m-audio.com/drivers. If this does not resolve the issue, check to see if the Fast Track C600 drivers are properly installed:

Windows Vista and Windows 7

- Go to the Windows Control Panel, double-click the Device Manager icon, and then:
 - Click the plus sign (Windows Vista) or triangle (Windows 7) next to “Sound, video and game controllers,” and locate the Fast Track C600 listing.

If you see a question mark or exclamation point next to it, or if it is not listed, try using a different USB cable and/or USB port on the host computer. If you still see the question mark or exclamation point, you may need to reinstall the drivers.

Music Software Configuration

- ◆ Make sure your music software has been configured for use with Fast Track C600.

Windows

- Open the Sound Control Panel (Windows Vista and Windows 7), and make sure Fast Track C600 is set as the Default Playback device.
- Check the audio preferences page in your music software to see if the correct ASIO or WDM drivers are selected.

Mac OS X

- Go to System Preferences > Sound, and select Fast Track C600 under the Input and Output tabs.
- Open the audio preferences page in your music software to see if the correct Core Audio drivers are selected.
- ◆ If Fast Track C600 is correctly installed and configured for your music software do the following:
 - Check the signal path to make sure the outputs are routed to your headphones, amplifier, or powered monitors.
 - Ensure that the Output Selector switches are set so that corresponding line output pairs are not muted. (The LEDs corresponding to the line-outputs for your speakers should be illuminated).
 - Ensure that the Volume Control knob is not turned down (fully counter-clockwise) otherwise your outputs will be muted.
 - Ensure that the Monitor Mixer in the Fast Track C600 Control Panel software is set correctly and that the outputs are not muted or turned down.

Before Updating Your System

Please check www.m-audio.com/drivers for a compatible driver before installing Microsoft or Apple operating system updates.

Before new device drivers are released, they are tested for use with operating system versions that are available at that time. When updates for an operating system are released, all M-Audio device drivers have to be re-tested and possibly updated to ensure proper operation.

We recommend not installing operating system updates until a driver has been posted to the M-Audio website for that specific operating system.

The M-Audio website (www.m-audio.com) contains the latest drivers and program updates, as well as useful links to news stories, FAQs, and technical support. We recommend checking this site regularly to ensure you have the latest drivers and most up-to-date information about this product.

Before You Call Avid Support

Register Your System

Register your Fast Track C600 online at: www.m-audio.com/support.

By registering, you become eligible to receive the following:

- Technical support information
- Software update and upgrade notices
- Hardware warranty information

Gather Important Information

Avid wants to help you resolve problems as quickly and efficiently as possible. If you collect the following information before you contact M-Audio Support, it will make the diagnosis of your problem easier if you have your computer's:

- Make, model, processor speed
- Amount of system RAM
- Operating system (version of Windows or Mac OS)

appendix b

Compliance Information

Environmental Compliance

Disposal of Waste Equipment by Users in the European Union



This symbol on the product or its packaging indicates that this product must not be disposed of with other waste. Instead, it is your responsibility to dispose of your waste equipment by handing it over to a designated collection point for the recycling of waste electrical and electronic equipment. The separate collection and recycling of your waste equipment at the time of disposal will help conserve natural resources and ensure that it is recycled in a manner that protects human health and the environment. For more information about where you can drop off your waste equipment for recycling, please contact your local city recycling office or the dealer from whom you purchased the product.

Proposition 65 Warning

⚠ *This product contains chemicals, including lead, known to the State of California to cause cancer and birth defects or other reproductive harm. Wash hands after handling.*

Perchlorate Notice

This product may contain a lithium coin battery. The State of California requires the following disclosure statement: "Perchlorate Material – special handling may apply, See www.dtsc.ca.gov/hazardouswaste/perchlorate."

Recycling Notice



EMC (Electromagnetic Compliance)

Avid declares that this product complies with the following standards regulating emissions and immunity:

- FCC Part 15 Class B
- EN 55022 Class B
- EN 55024 Class B
- AS/NZS CISPR 22 Class B
- CISPR 22 Class B

FCC Compliance for United States

Radio and Television Interference

Communication Statement

NOTE: This equipment has been tested and found to comply with the limits for a Class B digital device, pursuant to Part 15 of the FCC Rules. These limits are designed to provide reasonable protection against harmful interference in a residential installation. This equipment generates, uses, and can radiate radio frequency energy and, if not installed and used in accordance with the instructions, may cause harmful interference to radio communications. However, there is no guarantee that interference will not occur in a particular installation. If this equipment does cause harmful interference to radio or television reception, which can be determined by turning the equipment off and on, the user is encouraged to try and correct the interference by one or more of the following measures:

- Reorient or locate the receiving antenna.
- Increase the separation between the equipment and receiver.
- Connect the equipment into an outlet on a circuit different from that to which the receiver is connected.
- Consult the dealer or an experienced radio/TV technician for help.

Any modifications to the unit, unless expressly approved by Avid, could void the user's authority to operate the equipment.

Australian Compliance



Canadian Compliance

This Class B digital apparatus meets all requirements of the Canadian Interference-Causing Equipment Regulations.

Cet appareil numérique de la classe B respecte toutes les exigences du Règlement sur le matériel brouilleur du Canada.

CE Compliance (EMC and Safety)



Avid is authorized to apply the CE (Conformité Européenne) mark on this compliant equipment thereby declaring conformity to EMC Directive 2004/108/EC and Low Voltage Directive 2006/95/EC.

Safety Compliance

Safety Statement

This equipment has been tested to comply with USA and Canadian safety certification in accordance with the specifications of UL Standards: UL 60950-1, 2nd Edition/IEC 60950-1, 2nd Edition and Canadian CAN/CSA C22.2 No. 60950-1-07, 2007, 2nd Edition. Avid Technology Inc. has been authorized to apply the appropriate TUV & cTUV mark on its compliant equipment.

Warning



Korean EMC Regulations

이 기기는 가정용(B급) 전자파적합기기로서 주로 가정에서 사용하는 것을 목적으로 하며, 모든 지역에서 사용할 수 있습니다.

Japan VCCI Compliance

この装置は、クラスB情報技術装置です。この装置は、家庭環境で使用することを目的としていますが、この装置がラジオやテレビジョン受信機に近接して使用されると、受信障害を引き起こすことがあります。

取扱説明書に従って正しい取り扱いをして下さい。

VCCI-B

Important Safety Instructions

17) The equipment shall be used at a maximum ambient temperature of 40° C.

- 1) Read these instructions.
 - 2) Keep these instructions.
 - 3) Heed all warnings.
 - 4) Follow all instructions.
 - 5) Do not use this equipment near water.
 - 6) Clean only with dry cloth.
 - 7) Do not block any ventilation openings. Install in accordance with the manufacturer's instructions.
 - 8) Do not install near any heat sources such as radiators, heat registers, stoves, or other equipment (including amplifiers) that produce heat.
 - 9) Do not defeat the safety purpose of the polarized or grounding-type plug. A polarized plug has two blades with one wider than the other. A grounding type plug has two blades and a third grounding prong. The wide blade or the third prong are provided for your safety. If the provided plug does not fit into your outlet, consult an electrician for replacement of the obsolete outlet.
 - 10) Protect power cords from being walked on or pinched particularly at plugs, convenience receptacles, and the point where they exit from the equipment.
 - 11) Only use attachments/accessories specified by the manufacturer.
 - 12) For products that are not rack-mountable: Use only with a cart, stand, tripod, bracket, or table specified by the manufacturer, or sold with the equipment. When a cart is used, use caution when moving the cart/equipment combination to avoid injury from tip-over.
 - 13) Unplug this equipment during lightning storms or when unused for long periods of time.
 - 14) Refer all servicing to qualified service personnel. Servicing is required when the equipment has been damaged in any way, such as power-supply cord or plug is damaged, liquid has been spilled or objects have fallen into the equipment, the equipment has been exposed to rain or moisture, does not operate normally, or has been dropped.
 - 15) For products that are a Mains powered device:
The equipment shall not be exposed to dripping or splashing and no objects filled with liquids (such as vases) shall be placed on the equipment.
- Warning!** To reduce the risk of fire or electric shock, do not expose this equipment to rain or moisture.
- 16) For products containing a lithium battery:
CAUTION! Danger of explosion if battery is incorrectly replaced. Replace only with the same or equivalent type.

appendix c

Warranty

Avid warrants products to be free from defects in materials and workmanship, under normal use and provided that the product is owned by the original, registered user.

Visit www.m-audio.com/warranty for terms and limitations applying to your specific product.



Avid
5795 Martin Rd.
Irwindale, CA 91706 USA

Technical Support (USA)
Visit the Online Support Center at
www.m-audio.com/support

Product Information
For company and product information,
visit us on the web at www.avid.com