

INSTRUCTION MANUAL

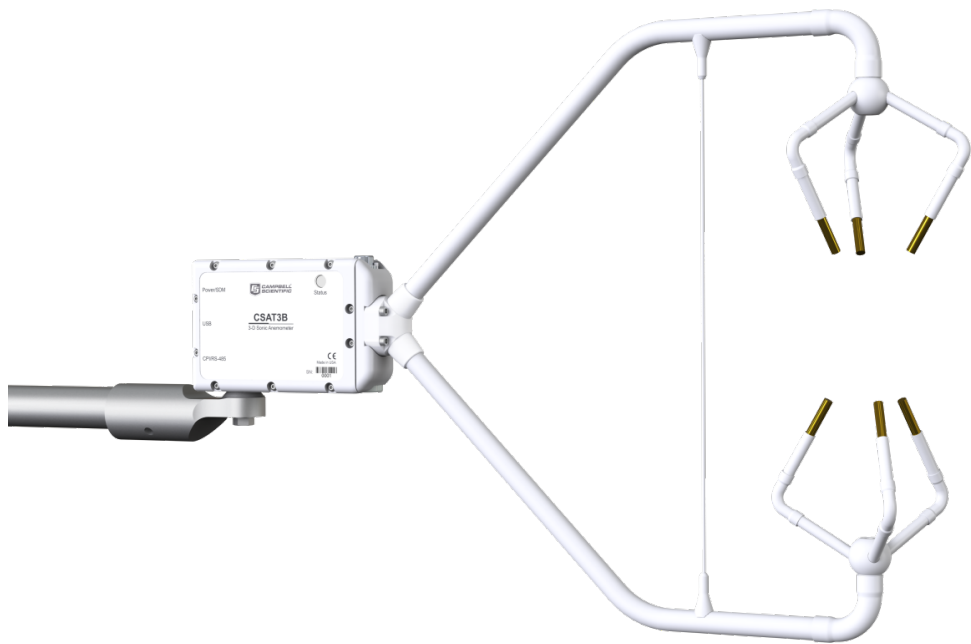

CSAT3B Three-Dimensional Sonic Anemometer

2/15



Limited Warranty

“Products manufactured by CSI are warranted by CSI to be free from defects in materials and workmanship under normal use and service for twelve months from the date of shipment unless otherwise specified in the corresponding product manual. (Product manuals are available for review online at www.campbellsci.com.) Products not manufactured by CSI, but that are resold by CSI, are warranted only to the limits extended by the original manufacturer. Batteries, fine-wire thermocouples, desiccant, and other consumables have no warranty. CSI’s obligation under this warranty is limited to repairing or replacing (at CSI’s option) defective Products, which shall be the sole and exclusive remedy under this warranty. The Customer assumes all costs of removing, reinstalling, and shipping defective Products to CSI. CSI will return such Products by surface carrier prepaid within the continental United States of America. To all other locations, CSI will return such Products best way CIP (port of entry) per Incoterms ® 2010. This warranty shall not apply to any Products which have been subjected to modification, misuse, neglect, improper service, accidents of nature, or shipping damage. This warranty is in lieu of all other warranties, expressed or implied. The warranty for installation services performed by CSI such as programming to customer specifications, electrical connections to Products manufactured by CSI, and Product specific training, is part of CSI’s product warranty. **CSI EXPRESSLY DISCLAIMS AND EXCLUDES ANY IMPLIED WARRANTIES OF MERCHANTABILITY OR FITNESS FOR A PARTICULAR PURPOSE. CSI hereby disclaims, to the fullest extent allowed by applicable law, any and all warranties and conditions with respect to the Products, whether express, implied or statutory, other than those expressly provided herein.”**

Assistance

Products may not be returned without prior authorization. The following contact information is for US and international customers residing in countries served by Campbell Scientific, Inc. directly. Affiliate companies handle repairs for customers within their territories. Please visit www.campbellsci.com to determine which Campbell Scientific company serves your country.

To obtain a Returned Materials Authorization (RMA), contact CAMPBELL SCIENTIFIC, INC., phone (435) 227-9000. After an application engineer determines the nature of the problem, an RMA number will be issued. Please write this number clearly on the outside of the shipping container. Campbell Scientific's shipping address is:

CAMPBELL SCIENTIFIC, INC.

RMA# _____
815 West 1800 North
Logan, Utah 84321-1784

For all returns, the customer must fill out a "Statement of Product Cleanliness and Decontamination" form and comply with the requirements specified in it. The form is available from our web site at www.campbellsci.com/repair. A completed form must be either emailed to repair@campbellsci.com or faxed to (435) 227-9106. Campbell Scientific is unable to process any returns until we receive this form. If the form is not received within three days of product receipt or is incomplete, the product will be returned to the customer at the customer's expense. Campbell Scientific reserves the right to refuse service on products that were exposed to contaminants that may cause health or safety concerns for our employees.

Precautions

DANGER — MANY HAZARDS ARE ASSOCIATED WITH INSTALLING, USING, MAINTAINING, AND WORKING ON OR AROUND TRIPODS, TOWERS, AND ANY ATTACHMENTS TO TRIPODS AND TOWERS SUCH AS SENSORS, CROSSARMS, ENCLOSURES, ANTENNAS, ETC. FAILURE TO PROPERLY AND COMPLETELY ASSEMBLE, INSTALL, OPERATE, USE, AND MAINTAIN TRIPODS, TOWERS, AND ATTACHMENTS, AND FAILURE TO HEED WARNINGS, INCREASES THE RISK OF DEATH, ACCIDENT, SERIOUS INJURY, PROPERTY DAMAGE, AND PRODUCT FAILURE. TAKE ALL REASONABLE PRECAUTIONS TO AVOID THESE HAZARDS. CHECK WITH YOUR ORGANIZATION'S SAFETY COORDINATOR (OR POLICY) FOR PROCEDURES AND REQUIRED PROTECTIVE EQUIPMENT PRIOR TO PERFORMING ANY WORK.

Use tripods, towers, and attachments to tripods and towers only for purposes for which they are designed. Do not exceed design limits. Be familiar and comply with all instructions provided in product manuals. Manuals are available at www.campbellsci.com or by telephoning (435) 227-9000 (USA). You are responsible for conformance with governing codes and regulations, including safety regulations, and the integrity and location of structures or land to which towers, tripods, and any attachments are attached. Installation sites should be evaluated and approved by a qualified engineer. If questions or concerns arise regarding installation, use, or maintenance of tripods, towers, attachments, or electrical connections, consult with a licensed and qualified engineer or electrician.

General

- Prior to performing site or installation work, obtain required approvals and permits. Comply with all governing structure-height regulations, such as those of the FAA in the USA.
- Use only qualified personnel for installation, use, and maintenance of tripods and towers, and any attachments to tripods and towers. The use of licensed and qualified contractors is highly recommended.
- Read all applicable instructions carefully and understand procedures thoroughly before beginning work.
- Wear a **hardhat** and **eye protection**, and take **other appropriate safety precautions** while working on or around tripods and towers.
- **Do not climb** tripods or towers at any time, and prohibit climbing by other persons. Take reasonable precautions to secure tripod and tower sites from trespassers.
- Use only manufacturer recommended parts, materials, and tools.

Utility and Electrical

- **You can be killed** or sustain serious bodily injury if the tripod, tower, or attachments you are installing, constructing, using, or maintaining, or a tool, stake, or anchor, come in **contact with overhead or underground utility lines**.
- Maintain a distance of at least one-and-one-half times structure height, 20 feet, or the distance required by applicable law, **whichever is greater**, between overhead utility lines and the structure (tripod, tower, attachments, or tools).
- Prior to performing site or installation work, inform all utility companies and have all underground utilities marked.
- Comply with all electrical codes. Electrical equipment and related grounding devices should be installed by a licensed and qualified electrician.

Elevated Work and Weather

- Exercise extreme caution when performing elevated work.
- Use appropriate equipment and safety practices.
- During installation and maintenance, keep tower and tripod sites clear of un-trained or non-essential personnel. Take precautions to prevent elevated tools and objects from dropping.
- Do not perform any work in inclement weather, including wind, rain, snow, lightning, etc.

Maintenance

- Periodically (at least yearly) check for wear and damage, including corrosion, stress cracks, frayed cables, loose cable clamps, cable tightness, etc. and take necessary corrective actions.
- Periodically (at least yearly) check electrical ground connections.

WHILE EVERY ATTEMPT IS MADE TO EMBODY THE HIGHEST DEGREE OF SAFETY IN ALL CAMPBELL SCIENTIFIC PRODUCTS, THE CUSTOMER ASSUMES ALL RISK FROM ANY INJURY RESULTING FROM IMPROPER INSTALLATION, USE, OR MAINTENANCE OF TRIPODS, TOWERS, OR ATTACHMENTS TO TRIPODS AND TOWERS SUCH AS SENSORS, CROSSARMS, ENCLOSURES, ANTENNAS, ETC.

Table of Contents

PDF viewers: These page numbers refer to the printed version of this document. Use the PDF reader bookmarks tab for links to specific sections.

1. Introduction	1
2. Cautionary Statements	1
3. Initial Inspection	1
4. Quickstart	2
4.1 Hardware Connections	2
4.2 Communications Connections	4
4.3 Factory Settings	8
5. Overview	8
5.1 Features	9
5.2 Sensor Components	9
5.2.1 Standard Components	9
5.2.1.1 CM250 Leveling Mounting Kit	9
5.2.1.2 USB Data Cable	10
5.2.1.3 Resource DVD	10
5.2.2 Optional Components	10
5.2.2.1 Sonic Carrying Case	10
5.2.3 Common Accessories	11
5.2.3.1 Power and Communications Cables	11
5.2.3.2 FW05 Thermocouple	13
5.2.3.3 FWC-L Cable	13
5.2.3.4 Thermocouple Cover	13
5.2.3.5 Thermocouple Cover Backplate	14
5.2.3.6 FW/ENC Thermocouple Enclosure	14
5.2.4 Other Accessories	14
5.2.4.1 Power/SDM Splitter	15
5.2.4.2 CPI/RS-485 Splitter	15
5.2.4.3 HUB-SDM8	15
5.2.4.4 SDM Cable CABLE5CBL-L	16
5.2.4.5 HUB-CPI	16
5.2.4.6 CAT6 Ethernet Cable	17
6. Specifications	17
6.1 Measurements	18
6.2 Communications	19
6.3 Power Requirements	19
6.4 Physical Description	20
7. Installation	21
7.1 Settings	21
7.2 Orientation	25

7.3	Mounting.....	25
7.4	Leveling.....	27
7.5	Additional Fast-response Sensors.....	28
7.5.1	Fine-Wire Thermocouple	28
7.5.2	Other Gas Analyzers	30
7.6	Wiring	30
7.7	Communications.....	31
7.7.1	SDM Communications.....	32
7.7.2	CPI Communications	36
7.7.3	RS-485 Communications	40
7.7.4	USB.....	42
8.	Operation	43
8.1	Theory of Operation.....	43
8.1.1	Algorithm Version 5	44
8.1.2	Effects of Crosswind on the Speed of Sound	44
8.2	Operating Modes	45
8.2.1	Measurement Trigger	46
8.2.2	Data Filter	46
8.2.3	Data Output.....	47
8.2.4	Operating Mode Recommendations.....	50
8.3	Synchronization with other sensors.....	50
8.4	Datalogger Programming using SDM or CPI.....	51
8.4.1	CRBasic Instructions.....	52
8.4.1.1	CSAT3B().....	52
8.4.1.2	CSAT3BMonitor().....	52
8.4.2	Diagnostic Word	53
8.4.3	SDMTrigger()	54
9.	Maintenance and Troubleshooting.....	55
9.1	General Maintenance.....	55
9.2	Sonic Wicks	55
9.3	Desiccant.....	56
9.4	Calibration.....	57
9.4.1	Test for Wind Offset	58
9.5	Troubleshooting	60
9.5.1	Sending an OS to the CSAT3B.....	60
9.6	Returning the CSAT3B	61
10.	Reference and Attributions	61
10.1	References	61
 Appendices		
A.	CSAT3B Orientation.....	A-1
A.1	Determining True North and Sensor Orientation	A-1
A.2	Online Magnetic Declination Calculator.....	A-3
B.	CSAT3B Measurement Theory.....	B-1
B.1	Theory of Operation.....	B-1
B.1.1	Wind Speed	B-1

B.1.2 Temperature B-2
 B.2 References..... B-3

C. Example CRBasic Datalogger Programs C-1

C.1 Simple SDM Program C-1
 C.2 Simple CPI Program C-2
 C.3 Advanced CPI Program C-3

Figures

4-1. Mounting a CM20X crossarm with crossarm-to-pole bracket 2
 4-2. CSAT3B mounting 3
 4-3. Grounding lug of CSAT3B 3
 4-4. Cable connection for SDM 4
 4-5. Cable connections for CPI 5
 4-6. SDM and power wiring to a CR1000 datalogger 6
 4-7. CPI and power connections to a CR6 datalogger 7
 4-8. Lit status light on CSAT3B block 7
 5-1. CM250 mount 9
 5-2. Campbell Scientific resource DVD 10
 5-3. Options for CSAT3BCBL1 Power/SDM cable 12
 5-4. Options for CSAT3BCBL2 power cable 12
 5-5. Options for cabling CPI or RS-485 communications 13
 5-6. FW05 thermocouple 13
 5-7. FW/ENC for storing fragile thermocouples 14
 5-8. CSAT3B Power/SDM splitter 15
 5-9. CSAT3B CPI/RS-485 splitter 15
 5-10. HUB-SDM8 for multiple CSAT3B connections with SDM
 communications 16
 5-11. HUB-CPI for multiple CSAT3B connections to CPI
 communications 17
 5-12. CAT6 Ethernet cable 17
 6-1. Dimensions of CSAT3B 21
 7-1. Connecting CSAT3B using *Device Configuration Utility* 22
 7-2. Real-time data subscreen while connected to CSAT3B with
 Device Configuration Utility 25
 7-3. CM210 mounting kit with CM20X crossarm 26
 7-4. CSAT3B mounting 27
 7-5. CSAT3B shown with coordinate system, with arrows representing
 positive x, y, and z axes 28
 7-6. Exploded view of fine-wire thermocouple with CSAT3B 29
 7-7. CSAT3B with fine-wire thermocouple mounted 30
 7-8. SDM/Power connections 33
 7-9. Wiring to power and SDM ports on CR1000 datalogger 33
 7-10. SDM daisy chain (CSAT3B sensor arms and grounding cables
 not shown) 35
 7-11. SDM star topology (CSAT3B sensors arms and grounding cables
 not shown) 36
 7-12. Power and CPI cable connections 37
 7-13. CPI connection to a CR6 datalogger 37
 7-14. CPI daisy chain (CSAT3B sensor arms and grounding cables not
 shown) 39
 7-15. CPI star topology (CSAT3B sensor arms and grounding cables
 not shown) 40
 7-16. RS-485 cable connections 41

8-1.	Measurement settings in <i>Device Configuration Utility</i>	45
8-2.	Example of unprompted RS-485 or USB output to PC	50
9-1.	Proper orientation of sonic top wick (left) and bottom wick (right)..	56
9-2.	Exploded view of CSAT3B desiccant canister.....	57
9-3.	CSAT3B real-time data with 1 sec update and u_x and u_y wind component graphed.....	59
9-4.	CSAT3B real-time data with 1 sec update and u_z wind component graphed	59
9-5.	The Send OS screen in the <i>Device Configuration Utility</i>	61
A-1.	Magnetic declination for the conterminous United States (2010) ...	A-1
A-2.	A declination angle east of true north (positive) is subtracted from 360 (0) degrees to find true north.....	A-2
A-3.	A declination angle west of true north (negative) is subtracted from 0 (360) degrees to find true north.....	A-2
A-4.	NOAA magnetic declination calculator	A-3
A-5.	NOAA magnetic calculator results.....	A-4

Tables

4-1.	Wiring Diagram for CSAT3B with SDM Communications	5
4-2.	CSAT3B Factory Settings	8
7-1.	CSAT3B Settings and Status Values in <i>Device Configuration Utility</i>	23
7-2.	Summary of Communications Options for the CSAT3B	31
7-3.	CSAT3B Cable Wire Assignments	43
7-4.	FW05/FWC-L Fine-Wire Thermocouple.....	43
8-1.	Overview of CSAT3B Operating Modes.	46
8-2.	Time Delays by Mode and Filter.....	47
8-3.	CSAT3B Synchronicity Errors.....	50
8-4.	Measurement Lags for Analog Measurements or Measurements with No Delay.....	51
8-5.	Diagnostic Word Flags.....	53

CSAT3B Three-Dimensional Sonic Anemometer

1. Introduction

The CSAT3B is an ultrasonic anemometer for measuring sonic temperature and wind speed in three dimensions. The CSAT3B can measure average horizontal wind speed and direction, or turbulent fluctuations of horizontal and vertical wind, and sonic temperature. Further, momentum flux and sensible heat flux can be calculated from the turbulent wind and sonic temperature fluctuations. Latent and sensible heat flux and gas fluxes may be determined by computing the covariance between vertical wind measured by the CSAT3B and scalar quantities measured by other appropriate sensors.

Before attempting to use or install the CSAT3B please review:

- Section 2, *Cautionary Statements*
- Section 3, *Initial Inspection*
- Section 4, *Quickstart*

2. Cautionary Statements

- READ AND UNDERSTAND the *Precautions* section at the front of this manual.
- CAUTION
 - Voltage input must be within range of 9.5 – 32 Vdc
 - The CSAT3B head should be handled by holding the block at the back of the sensor. Handling it by the arms or transducers could cause geometric deformation, which degrades the measurements.
 - The transducer faces are fragile. Care should be taken to avoid scratching or rubbing the surface of the transducer.
 - Grounding the CSAT3B is critical. Proper grounding to Earth will ensure maximum electrostatic discharge (ESD) and lightning protection and improve measurement accuracy.
- IMPORTANT
 - Install USB drivers and *Device Configuration Utility* before attaching sensor to PC

3. Initial Inspection

Upon receipt of the CSAT3B, inspect the packaging and contents for damage. File damage claims with the shipping company. Contact Campbell Scientific to facilitate repair or replacement.

Immediately check package contents against shipping documentation. Thoroughly check all packaging material for product that may be trapped inside. Contact Campbell Scientific about any discrepancies. Model numbers are found on each product. On cables, the model number is often found at the connection end of the cable. Check that correct lengths of cables are received.

The CSAT3B ships with:

- CM250 leveling mounting kit
- USB data cable, pn 30179
- Resource DVD
- Certificate of conformance

4. Quickstart

This Quickstart section covers only the very basic steps in setting up a CSAT3B using SDM or CPI communications with a Campbell Scientific datalogger. It is intended primarily as an overview and general reference for setup of a CSAT3B, and is not intended as a replacement for the more detailed information on installation found in Section 7, *Installation*.

4.1 Hardware Connections

1. Mount a 3.33 cm (1.31 in) outer diameter pipe or crossarm (such as a CM20X) to a tripod mast or tower as shown in FIGURE 4-1.

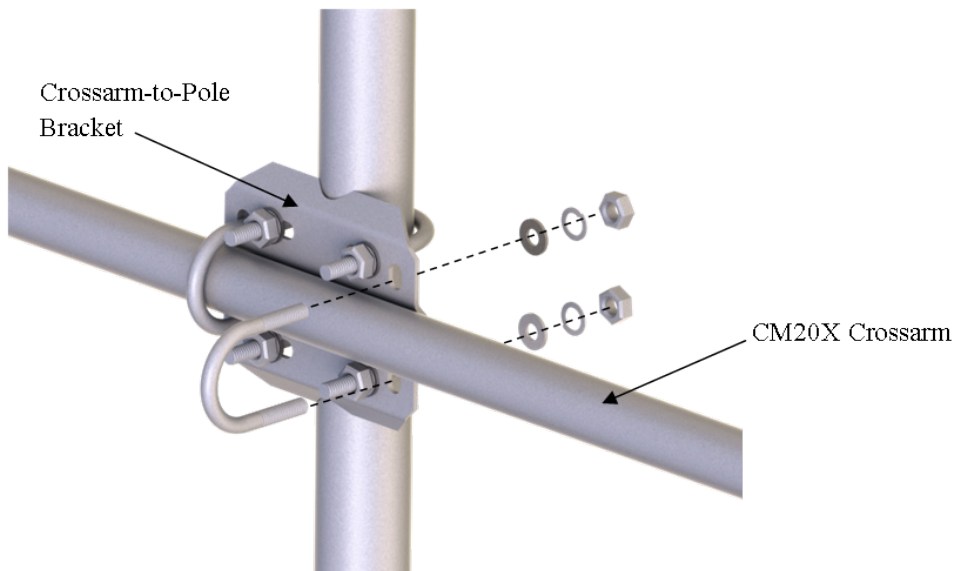

FIGURE 4-1. Mounting a CM20X crossarm with crossarm-to-pole bracket

2. Mount the CM250 leveling mount to the end of the crossarm as shown in FIGURE 4-2.
3. Use the captive bolt on the CM250 to mount the CSAT3B (FIGURE 4-2). The orientation of the CSAT3B should be level and pointing in the direction of the prevailing wind.

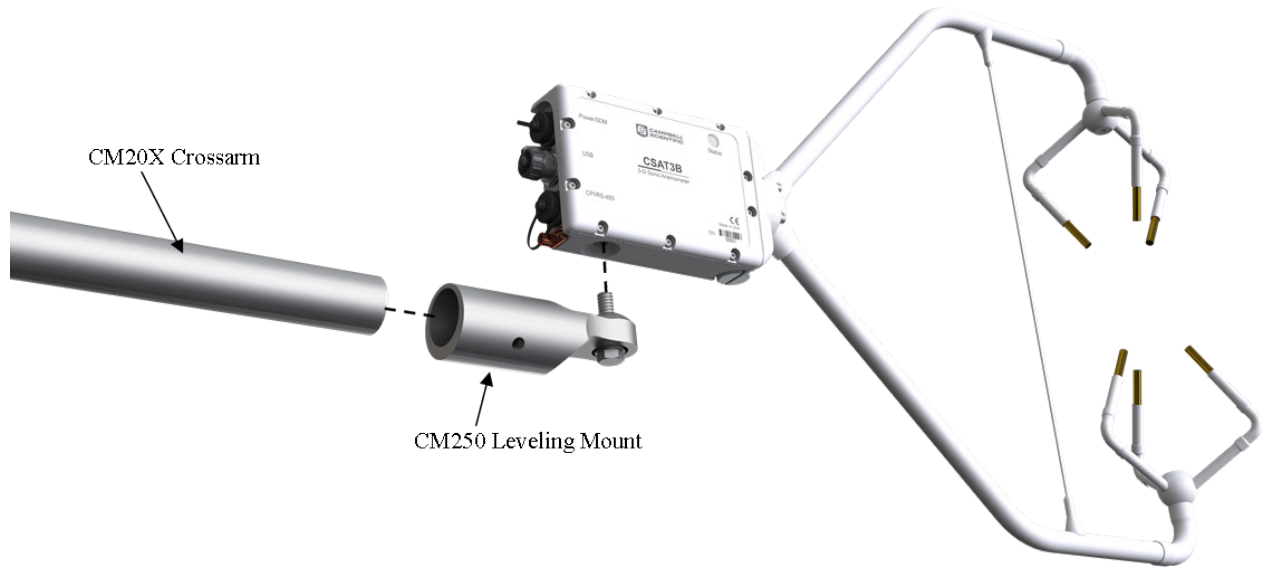

FIGURE 4-2. CSAT3B mounting

4. Ground the CSAT3B to the tower by attaching a user-supplied, heavy-gauge wire from the copper grounding lug on the back of the CSAT3B block (FIGURE 4-3).
5. Earth (chassis) ground the other end of the wire to the CSAT3B mounting structure or to a grounding rod. For more details on grounding, see the grounding section of the CR3000 datalogger manual.

NOTE

If connecting multiple CSAT3Bs together either in a series or a star topology, each CSAT3B must be separately grounded to either the mounting structure or a grounding rod.



FIGURE 4-3. Grounding lug of CSAT3B

CAUTION Grounding the CSAT3B is critical. Proper grounding to Earth (chassis) will ensure maximum ESD protection and improve measurement accuracy.

4.2 Communications Connections

1. Connect power and communication cable(s).

SDM Communications

If using SDM communications, connect a CSAT3BCBL1-L (“L” denotes the cable length in feet) cable to the connector on the back of the CSAT3B block labeled **Power/SDM** as shown in FIGURE 4-4.

CPI Communications

If using CPI communications, connect a CSAT3BCBL2-L cable and a CSAT3BCBL3-L-RJ to the connectors on the back of the CSAT3B block labelled **Power/SDM** and **CPI/RS-485**, respectively as shown in FIGURE 4-5.

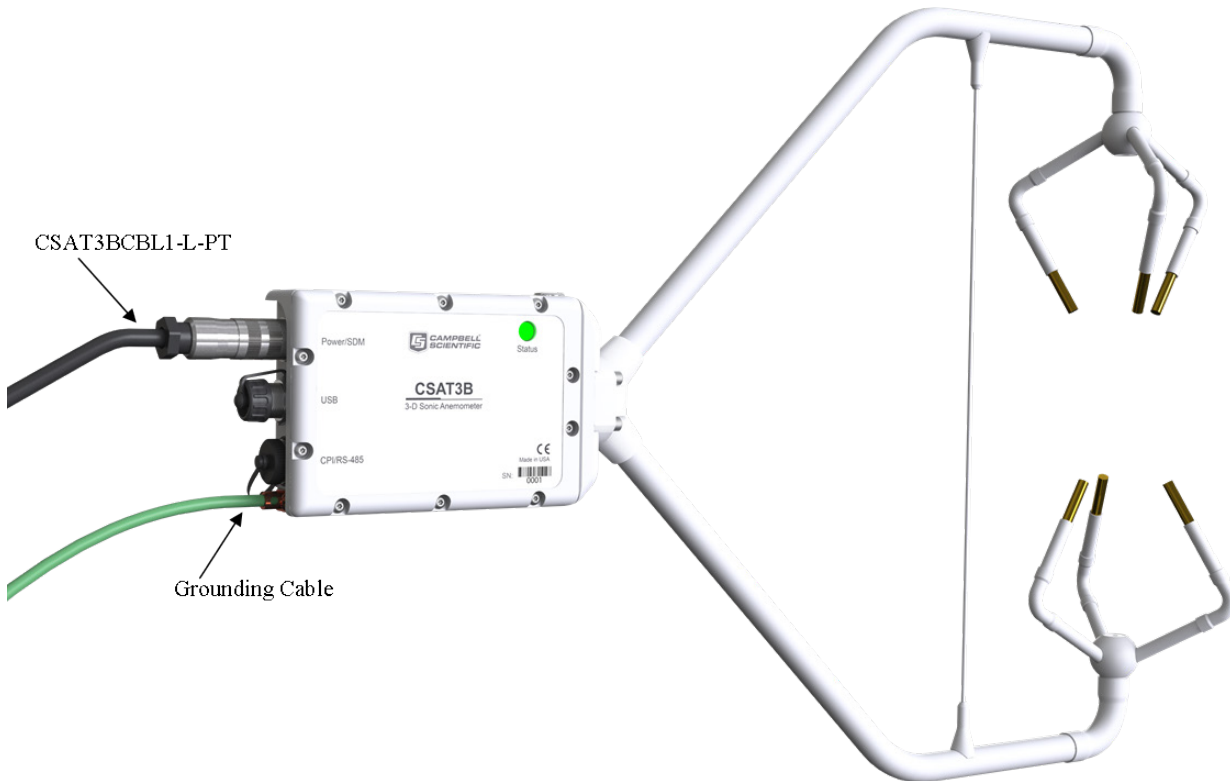

FIGURE 4-4. Cable connection for SDM

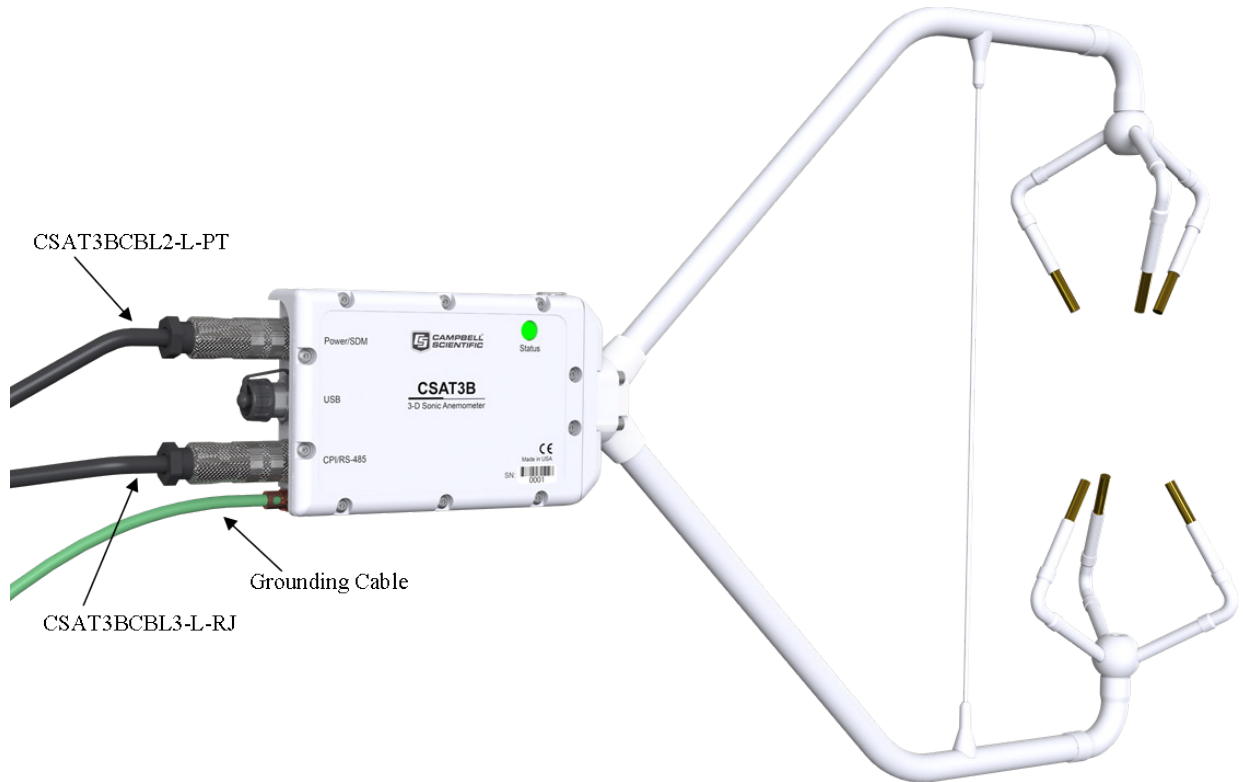

FIGURE 4-5. Cable connections for CPI

2. Connect power and communication cable(s) to datalogger.

SDM Communications

If using SDM communications, connect the wire leads on the end of the CSAT3BCBL1-L cable to the datalogger SDM and power ports according to TABLE 4-1. Refer to FIGURE 4-6 which shows these connections to a CR1000 datalogger.

TABLE 4-1. Wiring Diagram for CSAT3B with SDM Communications	
Datalogger Terminal	Wire Color
12 V (or other 9.5 to 32 Vdc source)	Red
Ground	Black
Ground	Brown
SDM C1	White
SDM C2	Yellow
SDM C3	Blue
Ground	Clear

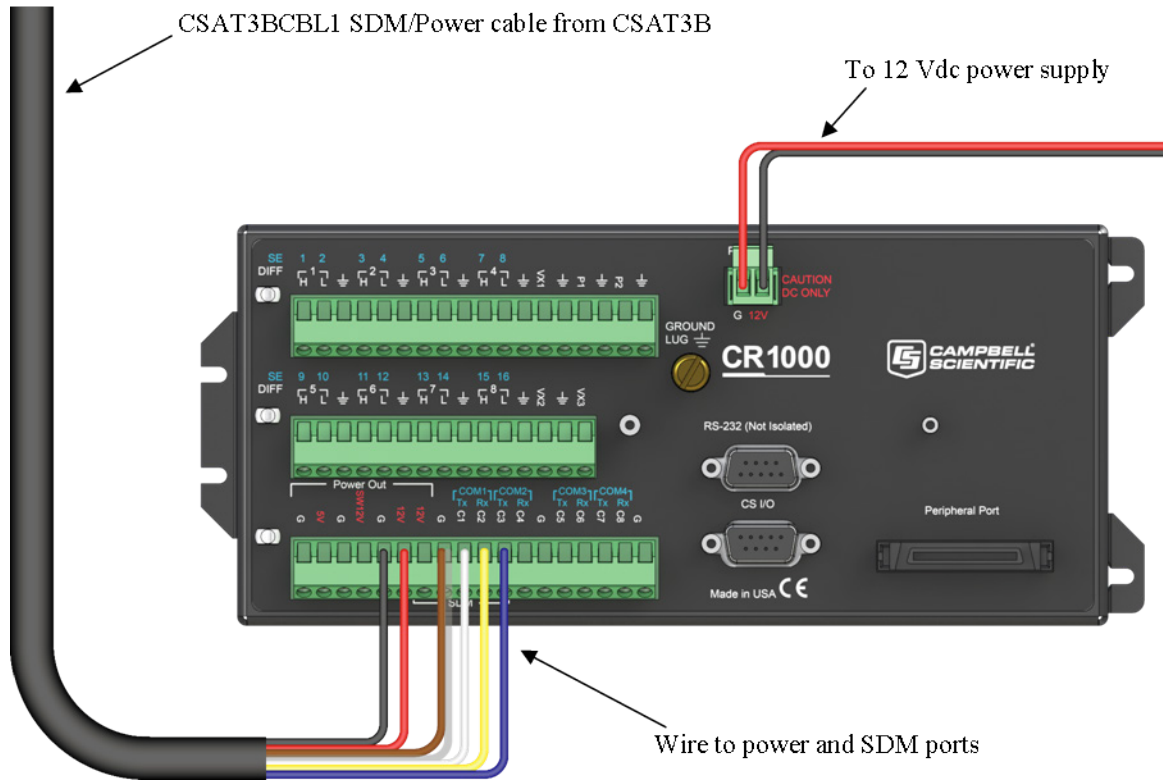

FIGURE 4-6. SDM and power wiring to a CR1000 datalogger

CPI Communications

With CPI communications, connect the red and black wires on the end of the CSAT3BCBL2-L-PT to the 12 V and ground terminals of a datalogger or to a 9.5 to 32 Vdc power supply. Connect the RJ-45 connector on the end of the CSAT3BCBL3-L-RJ to the CPI port on the CPI-compatible datalogger. Use FIGURE 4-7 as a reference.

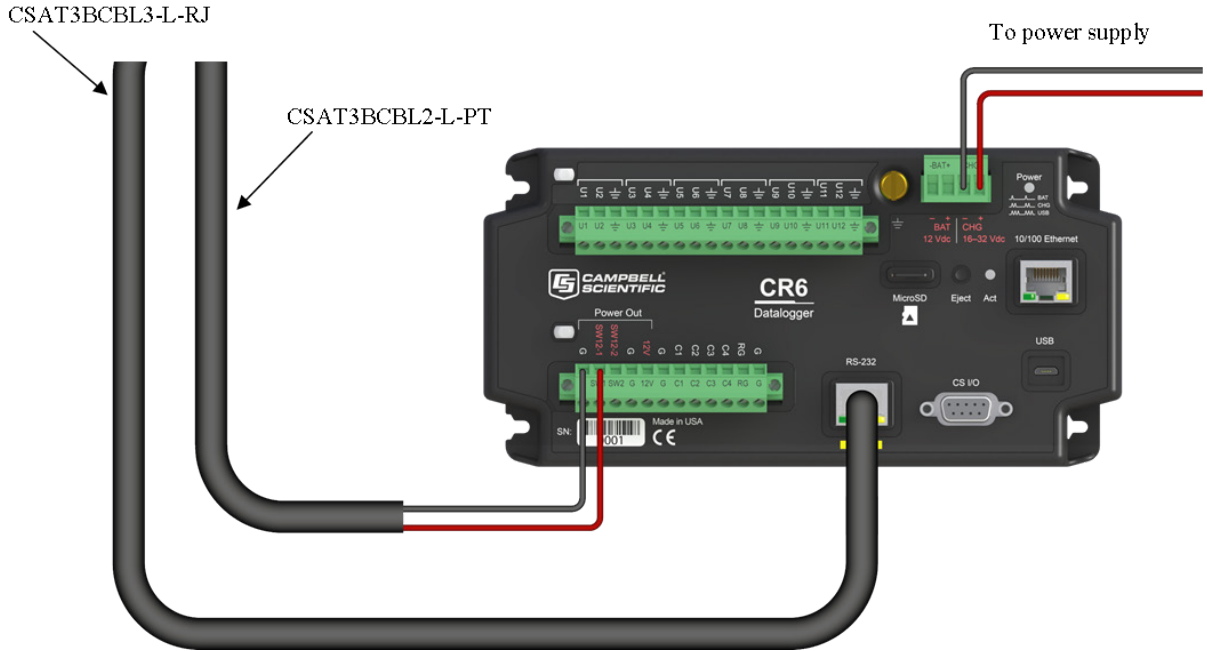

FIGURE 4-7. CPI and power connections to a CR6 datalogger

3. Use *LoggerNet*, *PC400*, or *PC200W* to send a datalogger program to the datalogger. See Section 8.4, *Datalogger Programming using SDM or CPI*, for more information on datalogger instructions and programming.
4. Verify that measurements are being made by ensuring the green **Status** light (FIGURE 4-8) on the CSAT3B block is blinking, indicating that measurements are being made and recorded in the datalogger without diagnostic error conditions.

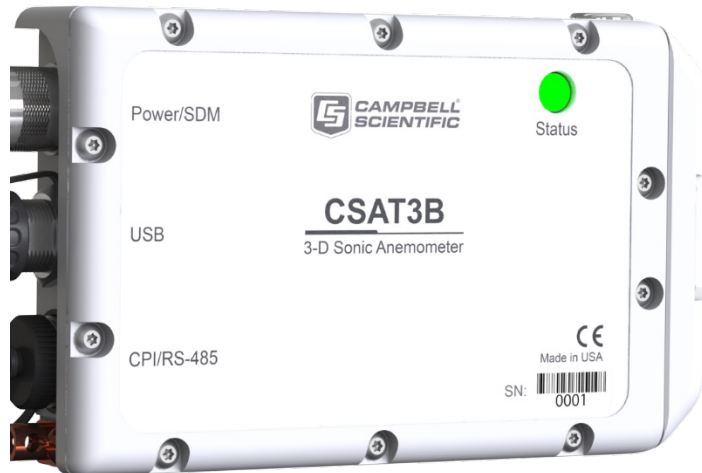

FIGURE 4-8. Lit status light on CSAT3B block

4.3 Factory Settings

The CSAT3B is shipped from the factory with the default settings that are shown in TABLE 4-2. These settings can be changed with a PC running Campbell Scientific’s *Device Configuration Utility*, version 2.10 or newer, and the USB cable that shipped with the CSAT3B. *Device Configuration Utility* is available from the Campbell Scientific website in the Support | Downloads section and is included with *PC200W*, *PC400*, and *LoggerNet* software packages.

TABLE 4-2. CSAT3B Factory Settings

	Setting	Default
Communication Settings	SDM address	3
	CPI address	30
	CPI/RS-485 Communication Port Protocol	CPI Enabled
	CPI Baud Rate	Auto
	RS-485 Baud Rate	115200
	Unprompted Output Port	Disabled
	Unprompted Output Rate	10 Hz
Measurement Setting	Operating Mode	Mode 1: Datalogger-Trigger/No Filter/ Datalogger-Prompted Output

5. Overview

The CSAT3B is an ultrasonic anemometer for measuring sonic temperature and wind speed in three dimensions. It is often used for studies of turbulence and flux measurement, where turbulent fluctuations of wind speed and sonic temperature must be measured at high frequencies; at 10Hz, for example.

From the turbulent wind fluctuations, momentum flux can be calculated. The covariance of vertical wind and sonic temperature yields sonic sensible heat flux. By finding the covariance between vertical wind and scalar measurements made by other fast-response sensors, such as fine-wire thermocouples or gas analyzers, other fluxes can be calculated. For example, sensible and latent-heat fluxes, carbon-dioxide flux, and other trace-gas fluxes, can all be measured by combining the CSAT3B with other sensors.

The CSAT3B can communicate measurements using SDM (Synchronous Device for Measurements), USB, RS-485, and CPI (CAN Peripheral Interface) communications. For optimal synchronization with other fast-response sensors for applications such as eddy covariance, Campbell Scientific recommends using SDM or CPI communications with an appropriate Campbell Scientific datalogger.

5.1 Features

The CSAT3B offers the following key features:

- Integrated electronics provide easy mounting of a single piece of hardware
- Integrated inclinometer
- High-precision measurements ideal for turbulence and eddy covariance studies
- An improved design with a thin, aerodynamic support strut close to the ends of the sensor arms, creating greater rigidity and improved accuracy of sonic temperature
- Supports datalogger sampling at any frequency between 1 and 100 Hz
- New CPI communications for more robust, higher bandwidth measurements
- Multiple communication options including SDM, CPI, USB, and RS-485
- Internal temperature and humidity measurements with easily replaced desiccant
- Version 5 algorithm for calculating data outputs; combines the signal sensitivity of version 3 with the rain performance of version 4
- Includes options to filter high frequencies for applications requiring analysis of non-aliased spectra

5.2 Sensor Components

The CSAT3B consists of several components. Some components come standard with every CSAT3B; others are considered accessories that must be ordered separately. Some common accessories such as cables are required to operate a CSAT3B.

5.2.1 Standard Components

Standard components are items that are included or shipped with the CSAT3B. The following sections describe these items.

5.2.1.1 CM250 Leveling Mounting Kit

The CM250 leveling mounting kit is shipped with the CSAT3B and comes with an adapter (FIGURE 5-1) that facilitates mounting a CSAT3B at the end of a 3.33 cm (1.31 in) OD crossarm or pipe. The kit includes a captive 3/8-in bolt that screws into the bottom of the CSAT3B block, and a 3/16-in Allen wrench to tighten the adapter on the pipe.

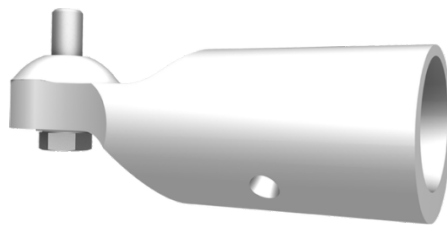

FIGURE 5-1. CM250 mount

5.2.1.2 USB Data Cable

The USB data cable (pn 30179) is a 5 m (16 ft) USB cable included with the CSAT3B. One end has a standard type-A male connector to connect to a PC, while the opposite end has a mini-B male connector, which connects to the USB port on the back of the CSAT3B block. The mini-B male connector is rated to Ingress Protection 68 (IP68) to exclude fine dust and water. When connected with the cable, *Device Configuration Utility* allows the user to view or set settings, send a new operating system to the CSAT3B, or view real-time measurements. It is also possible to use this cable to collect data with a PC in unprompted USB mode. Section 6.2, *Communications*, provides additional information.

5.2.1.3 Resource DVD

The resource DVD contains files for all product manuals and other product literature for Campbell Scientific products.

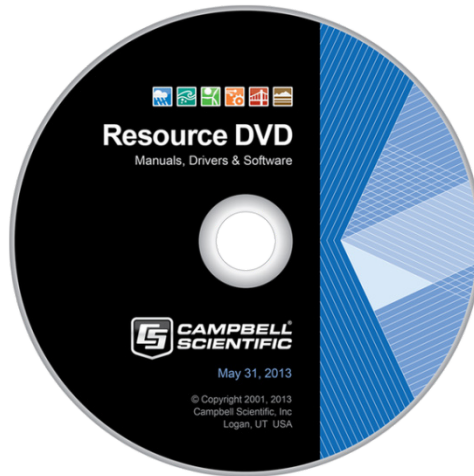

FIGURE 5-2. Campbell Scientific resource DVD

5.2.2 Optional Components

5.2.2.1 Sonic Carrying Case

A large, hard plastic Pelican™ carrying case is available for the CSAT3B. It is watertight and highly durable. This case is recommended for transporting and storing the CSAT3B. It includes a set of foam inserts that hold the CSAT3B in a protected position while providing space for additional components.

If opting out of the sonic carrying case, the CSAT3B will be shipped in a large cardboard box. The same set of foam inserts used in the sonic carrying case is used in the cardboard box to securely hold the CSAT3B.

NOTE

If choosing the cardboard box for shipping, it is recommended to keep the foam inserts and box. When returning a CSAT3B for factory recalibration or repair, it is important to ship the unit with the foam inserts provided from the factory.

5.2.3 Common Accessories

Common accessories for the CSAT3B include cables as well as other equipment to make sensible heat flux measurements. A fine-wire thermocouple is an example of an additional sensor often used with a CSAT3B. Descriptions of cables and other common accessories are described in greater detail in the following sections.

5.2.3.1 Power and Communications Cables

Cables required for the CSAT3B to be functional, must be ordered along with the CSAT3B. The types of cables needed for a specific communications mode, are outlined below.

NOTE

Unlike the earlier CSAT3, default-length cables are not included. This allows the user to specify the exact length, communication type, and connector type of the cable(s) needed for the application.

Campbell Scientific uses a system for naming cables that provide specific information about details of the cable and some information about the use of the cable.

- The ‘-L’ in the cable model name is an option that denotes a user-specified length of cable in feet.
- The ‘-PT’ is a cable option that specifies one end of the cable to have pigtail wires for wiring to a power source, datalogger terminals, or a wiring bus. The other end has an M16 connector for connecting to the corresponding port at the back of the CSAT3B block.
- The ‘-MC’ option designates an M16 connector on both ends of the cable and is used to daisy-chain several CSAT3B instruments together in series.

NOTE

Daisy-chaining requires ordering the 30293 splitter (see Section 5.2.4.1, *Power/SDM Splitter*, and Section 5.2.4.2, *CPI/RS-485 Splitter*) for each CSAT3B in series, except the terminal one.

- The ‘-RJ’ option has an RJ-45 connector on one end for connecting directly to the CPI port on a datalogger such as the CR6 or to a CPI port on the HUB-CPI if a network of several CPI devices are being installed in a star topology. The other end of the cable has an M16 connector for connecting to the CSAT3B block. The types of cables needed for a specific communications mode are outlined below. For information on maximum cable lengths, refer to the communications specifications in Section 6.2, *Communications*.

Power/SDM Cable (CSAT3BCBL1)

To use SDM communications to collect data from a CSAT3B with a datalogger, the CSAT3BCBL1-L-PT or CSAT3BCBL1-L-MC should be ordered. The two versions are shown in FIGURE 5-3. This cable is used to transmit both power and SDM communication signals.

NOTE To collect data through another means (CPI, RS-485, USB), the CSAT3BCBL1 Power/SDM cable may still be used to provide power to the CSAT3B, in which case the SDM wires should be left unwired to any ports on the datalogger.

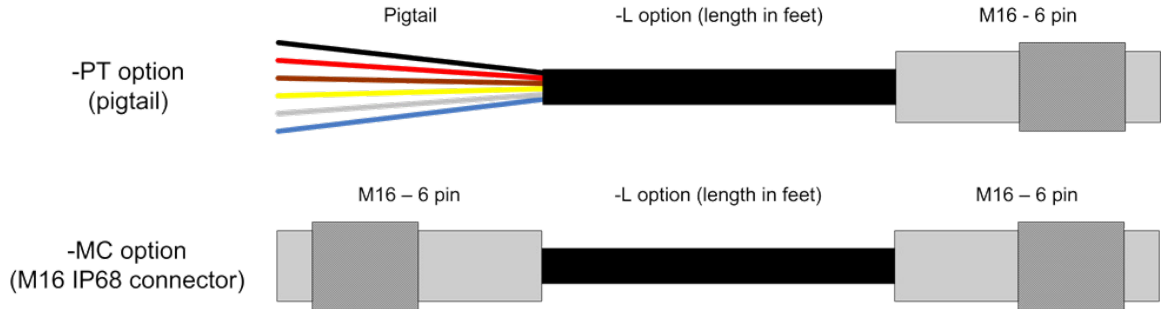

FIGURE 5-3. Options for CSAT3BCBL1 Power/SDM cable

Power Cable (CSAT3BCBL2)

To use CPI, RS-485, or USB communications to collect data from a CSAT3B, the CSAT3BCBL2-L-PT or CSAT3BCBL2-L-MC should be ordered to provide power to the sensor. A second cable to transmit the communications is also required (for example, CSAT3BCBL3 CPI/RS-485 cable for CPI or RS-485, or the 30179 USB data cable).

For installations with long cable lengths, the CSAT3BCBL2 is preferred over the CSAT3BCBL1 for providing power due to the heavier gauge wires that reduce voltage drop over long distances.

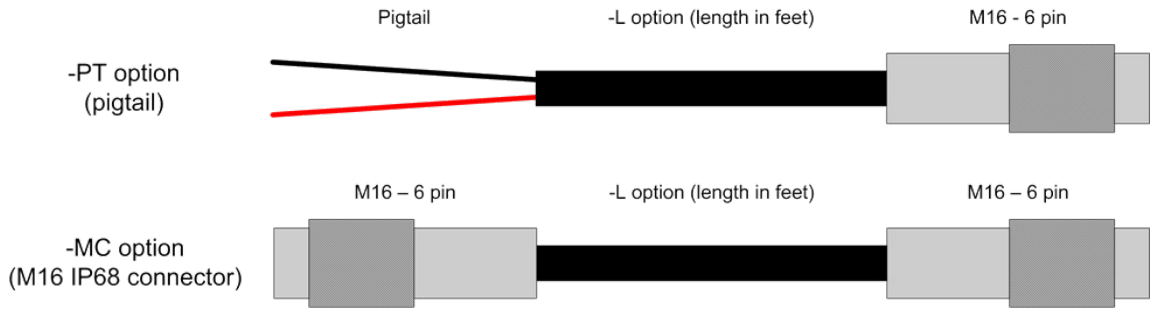

FIGURE 5-4. Options for CSAT3BCBL2 power cable

CPI/RS-485 Cable (CSAT3BCBL3)

To use CPI or RS-485 communications to collect data from a CSAT3B, the CSAT3BCBL3-L-PT, CSAT3BCBL3-L-RJ, or CSAT3BCBL3-L-MC, should be ordered in addition to a cable to provide power to the sensor (for example, either the CSAT3BCBL1 or CSAT3CBL2).

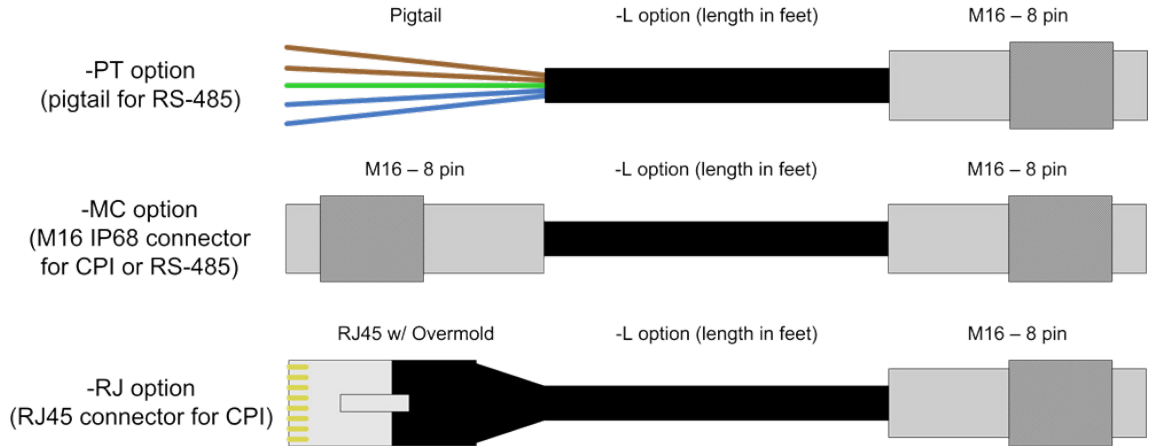

FIGURE 5-5. Options for cabling CPI or RS-485 communications

5.2.3.2 FW05 Thermocouple

The FW05 is a Type E thermocouple with a 0.0127 mm (0.0005 in) diameter (FIGURE 5-6). The thermocouple measures atmospheric temperature fluctuations and may be used with the CSAT3B to directly calculate sensible heat flux. Larger size fine-wire thermocouples, such as the FW1 and FW3, which are more robust but have slower response times, may also be used with the CSAT3B.



FIGURE 5-6. FW05 thermocouple

5.2.3.3 FWC-L Cable

The FWC-L is a cable with connector that mates with the connector on a FW05, FW1, or FW3 fine-wire thermocouple. The other end of the cable has pigtail wires to wire to a pair of differential voltage channels on a datalogger. The -L denotes the length of cable in feet, which can be designated at the time of ordering.

5.2.3.4 Thermocouple Cover

The TC cover (pn 10080) is a white metal, thermocouple cover that is placed over the connectors of the FW05 and the FWC-L cable. It is used to mount the connectors to the side of the CSAT3B block. It also minimizes temperature gradients across the connectors.

5.2.3.5 Thermocouple Cover Backplate

The thermocouple cover backplate (pn 31423) attaches to the CSAT3B block and is used to cover the back side of the thermocouple (TC) cover.

NOTE The backplate is required for the CSAT3B but not for other Campbell sonic anemometers. In the case of previous models, the back side of the TC cover is covered by the sensor block.

5.2.3.6 FW/ENC Thermocouple Enclosure

The FW/ENC is a small case (FIGURE 5-7) that is used for storing up to four fine-wire thermocouples. Due to the fragile nature of the FW05 thermocouple, it should always be stored in an FW/ENC when not in use. It is also recommended to order, at a minimum, a set of four FW05 thermocouples for every CSAT3B as the FW05 will break during normal wear and tear in the field.

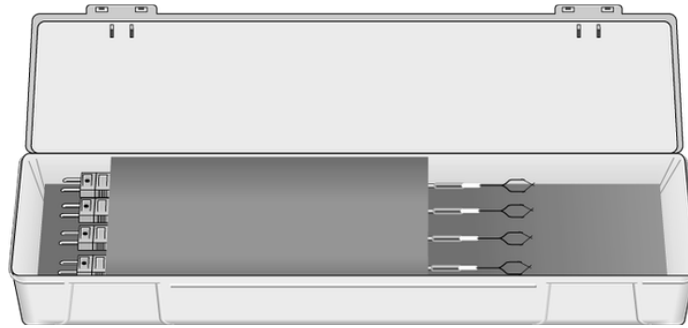

FIGURE 5-7. FW/ENC for storing fragile thermocouples

5.2.4 Other Accessories

The other accessories available for the CSAT3B are used when combining multiple CSAT3B units into a network of sensors, the data from which are collected by a single datalogger. Networks of CSAT3Bs using SDM or CPI communications may be configured in three different configurations:

- In a series, using a daisy-chain topology
- In parallel, using a star topology, or
- In a combination of daisy-chain and star topology

When designing an SDM or CPI network, careful attention should be given not to exceed a total network cable length that will excessively attenuate the sensor signals. The exact total length will depend on factors such as sample rate and topology, but in general the maximum cable lengths (given in Section 6.2, *Communications*) for each communication type and data rate should be followed.

Because CPI communications can support longer network cable lengths, it is generally recommended as the communication method for sensor networks. For more detailed information on network topologies and limits on cable lengths for CPI networks, see the white paper titled *Designing Physical Network Layouts for the CPI Bus*, available at www.campbellsci.com.

5.2.4.1 Power/SDM Splitter

The Power/SDM splitter (pn 30293) has three 6-pin M16 connectors. The splitter, shown in FIGURE 5-8, allows connection at the **Power/SDM** port on the back of the CSAT3B block to two CSAT3BCBL1 or CSAT3BCBL2 cables. The splitter is IP68 rated, meaning it is dust and watertight. It is used for daisy-chaining multiple CSAT3Bs in series. A Power/SDM Splitter is required for each CSAT3B in the daisy-chain (regardless of communication method used) except for the terminal one.

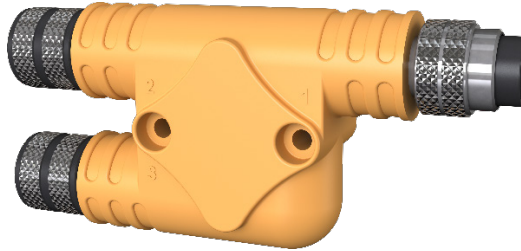

FIGURE 5-8. CSAT3B Power/SDM splitter

5.2.4.2 CPI/RS-485 Splitter

The CPI/RS-485 splitter (pn 30294) has three 8-pin M16 connectors. The splitter allows connection at the **CPI/RS-485** port on the back of the CSAT3B block to two CSAT3BCBL3 cables. The splitter is IP68 rated. It is used for daisy-chaining multiple CSAT3Bs in series that use CPI or RS-485 communications. A splitter is required for each CSAT3B in the daisy-chain, except for the terminal one. For a daisy-chain of CSAT3Bs using SDM communications, the CPI/RS-485 splitter is not needed. Only the Power/SDM splitter (see Section 5.2.4.1, *Power/SDM Splitter*) is needed.

NOTE

Both splitters, pn 30293 and pn 30294, look similar; however, they have a different number of pins and are not interchangeable.

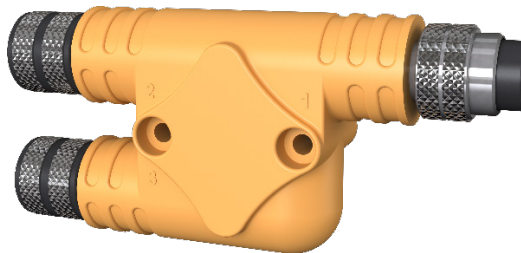

FIGURE 5-9. CSAT3B CPI/RS-485 splitter

5.2.4.3 HUB-SDM8

The HUB-SDM8 (pn 20759) allows up to six SDM devices (typically, one datalogger and multiple SDM sensors) to be connected together in parallel. It is shown in FIGURE 5-10. In the case of the CSAT3B, up to five CSAT3Bs, or CSAT3B daisy-chains using CSAT3BCBL1 cables, may be connected to the HUB-SDM8. In cases where multiple CSAT3Bs are installed some

distance from the datalogger, the HUB-SDM8 can be placed near the CSAT3Bs with a single SDM cable extended from the hub to the datalogger. This decreases the total network cable length, which limits signal attenuation.

The HUB-SDM8 has eight terminal strips and features spring-loaded guillotine terminals for easy wiring. It comes in a watertight enclosure and includes a U-bolt for mounting to a vertical pipe or mast. An SDM Cable (CABLE5CBL-L; see Section 5.2.4.4, *SDM Cable CABLE5CBL-L*) should be ordered to connect the HUB-SDM8 to a datalogger and a power supply.



FIGURE 5-10. HUB-SDM8 for multiple CSAT3B connections with SDM communications

5.2.4.4 SDM Cable CABLE5CBL-L

The SDM cable, CABLE5CBL-L, is a 22 AWG, five-conductor cable with a Santoprene jacket and an aluminum Mylar[®] shield. By default, the conductors are stripped and tinned.

The CABLE5CBL-L is used to connect the power and SDM connection from a HUB-SDM8 to the power and SDM connections on a power source and datalogger.

5.2.4.5 HUB-CPI

The HUB-CPI (pn 30692) allows up to eight CPI devices to be connected together in parallel. In the case of the CSAT3B, up to seven CSAT3Bs, or CSAT3B daisy-chains using CSAT3BCBL3 cables, may be connected in parallel to the HUB-CPI. The remaining port may be used with a CAT5e or CAT6 Ethernet cable (see Section 5.2.4.4, *SDM Cable CABLE5CBL-L*) to connect the HUB-CPI to the CPI port on a datalogger such as the CR6.

The HUB-CPI (shown in FIGURE 5-11) is not weatherproof and should be housed in an enclosure, typically alongside the datalogger.

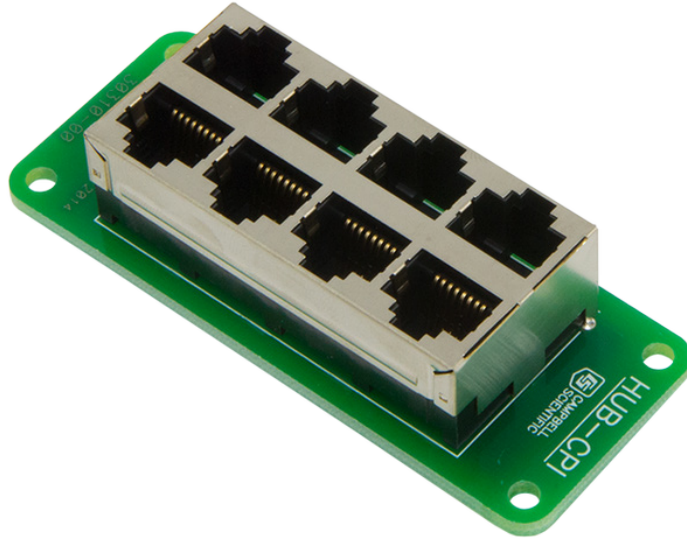

FIGURE 5-11. HUB-CPI for multiple CSAT3B connections to CPI communications

5.2.4.6 CAT6 Ethernet Cable

The CAT6 Ethernet cable (pn 28899) is a 61 cm (2 ft), unshielded CAT6 network cable with RJ45 connectors. It is typically used to connect the HUB-CPI to the CPI port on a datalogger such as the CR6.



FIGURE 5-12. CAT6 Ethernet cable

6. Specifications

The CSAT3B measures wind speed and the speed of sound along the three non-orthogonal sonic axes. The wind speeds are then transformed into the orthogonal wind components u_x , u_y , and u_z , and are referenced to the anemometer head. The reported ultrasonic air temperature (T_s) is the average between the temperatures computed for the three non-orthogonal sonic axes.

The vector component of the wind that is normal to each sonic axis (such as a crosswind) leads to a measurement error that is corrected online by the

CSAT3B before the wind speed is transformed into orthogonal coordinates. Because of this correction, it is not necessary to apply the speed of sound correction described by Liu et al., 2001 (see Section 10.1, *References*).

The CSAT3B has several operating modes to suit different applications. The anemometer can be configured to make a single measurement per datalogger trigger, or it can operate in a self-triggered mode. When self-triggering, the CSAT3B will make measurements at a high rate and provide the latest output upon receiving each datalogger trigger. In either operating mode, various filters can be applied to the output samples to limit the bandwidth of the output data. The default of the CSAT3B is to make measurements when triggered by a datalogger (SDM or CPI) and not apply any low-pass (high-cut) filtering. See Section 4.2, *Communications Connections*, for a list of all default settings.

6.1 Measurements

Operating Temperature Standard:	-30 to 50 °C
Wind Accuracy (-40 to 50 °C, wind speed < 30 m·s ⁻¹ , azimuth angles between ± 170 °C)	
Offset Error	
u _x :	± 8 cm·s ⁻¹ max
u _y :	± 8 cm·s ⁻¹ max
u _z :	± 4 cm·s ⁻¹ max
Gain Error	
Wind Vector ±5° of horizontal:	± 2% of reading max
Wind Vector ±10° of horizontal:	± 3% of reading max
Wind Vector ±20° of horizontal:	± 6% of reading max
Wind Resolution	
u _x :	1.0 mm·s ⁻¹ RMS
u _y :	1.0 mm·s ⁻¹ RMS
u _z :	0.5 mm·s ⁻¹ RMS
Wind Full Scale Range:	± 65 m·s ⁻¹
Sonic Temperature Resolution:	± 0.002 °C RMS at 25 °C
Sonic Temperature Reporting Range:	-30 to 50 °C
Measurement Rates	
Datalogger Triggered:	1–100 Hz
Unprompted Output (to PC):	10, 20, 50, or 100 Hz
Internal Self-Trigger Rate:	100 Hz
Measurement Delay	
Datalogger-Triggered (no filter):	1 trigger period (1 scan interval)
Unprompted Output (no filter):	10 ms
Filtered Output (Datalogger-Prompted or Unprompted to PC):	
	795 ms with 5 Hz bandwidth filter
	395 ms with 10 Hz bandwidth filter
	195 ms with 20 Hz bandwidth filter
	155 ms with 25 Hz bandwidth filter
Filter Bandwidths:	5, 10, 20, or 25 Hz

Internal Monitor Measurements

Update Rate:	2 Hz
Inclinometer Accuracy:	± 1 °
Relative Humidity Accuracy:	± 3% over 10 – 90% range ± 7% over 0 – 10% range ± 7% over 90 – 100% range
Board Temperature Accuracy:	± 2 °C

6.2 Communications

SDM: Used for datalogger-based data acquisition.

Bit Period:	10 µs to 1 ms
Cable Length:	7.6 m (25 ft) max @ 10 µs bit period 76 m (250 ft) max @ 1 ms bit period
Address Range:	1 – 14
Bus Clocks per Sample:	~200

CPI: Used for datalogger-based data acquisition.

Baud Rate:	50 kbps to 1 Mbps
Cable Lengthⁱ:	15 m (50 ft) max @ 1 Mbps 122 m (400 ft) max @ 250 kbps 853 m (2800 ft) max @ 50 kbps
Address Range:	1 – 120
Bus Clocks per Sample:	~300

RS-485: Used for anemometer configuration or PC-based data acquisition.

Baud Rate:	9.6 kbps to 115.2 kbps
Cable Length:	305 m (1000 ft) max @ 115.2 kbps 610 m (2000 ft) max @ 9.6 kbps
Bus Clocks per Sample:	~500 (ASCII formatted)

USB: Used for anemometer configuration or PC-based data acquisition.

Connection Speed:	USB 2.0 full speed 12 Mbps
Cable Length:	5 m max

6.3 Power Requirements

Voltage Requirement: 9.5 – 32 Vdc

Current Requirement (10 Hz Measurement Rate)

Current @ 12 Vdc:	110 mA
Current @ 24 Vdc:	65 mA

Current Requirement (100 Hz Measurement Rate)

Current @ 12 Vdc:	145 mA
Current @ 24 Vdc:	80 mA

ⁱ For additional details, refer to CSI whitepaper “Designing Physical Network Layouts for the CPI Bus”

6.4 Physical Description

Dimensions

Anemometer Overall:	60.7 cm (23.9 in) length 43.0 cm (16.9 in) height 12.2 cm (4.8 in) width
Measurement Path:	10.0 cm (3.9 in) vertical 5.8 cm (2.3 in) horizontal
Transducer Angle:	60 degrees from horizontal
Transducer Diameter:	0.64 cm (0.25 in)
Transducer Mounting Diameter:	0.84 cm (0.33 in)
Support Arm Diameter:	1.59 cm (0.63 in)
Cardboard Box with Foam:	73.7 x 45.7 x 25.4 cm (29 x 18 x 10 in)
Carrying Case with Foam:	79.5 x 51.8 x 31 cm (31.3 x 20.4 x 12.2 in)

Weight

Anemometer Head:	1.45 kg (3.2 lb)
Including Cardboard Box Option:	5.3 kg (11.7 lb)
Including Carrying Case Option:	13.4 kg (29.5 lb)

Shipping (Both cardboard and carrying cases options are shipped within a second box)

Cardboard Box Option

Weight:	9.1 kg (20.0 lb)
Dimensions:	91 x 51 x 41 cm (36 x 20 x 16 in)

Carrying Case Option

Weight:	16.3 (36.0 lb)
Dimensions:	81 x 66 x 43 cm (32 x 26 x 17 in)

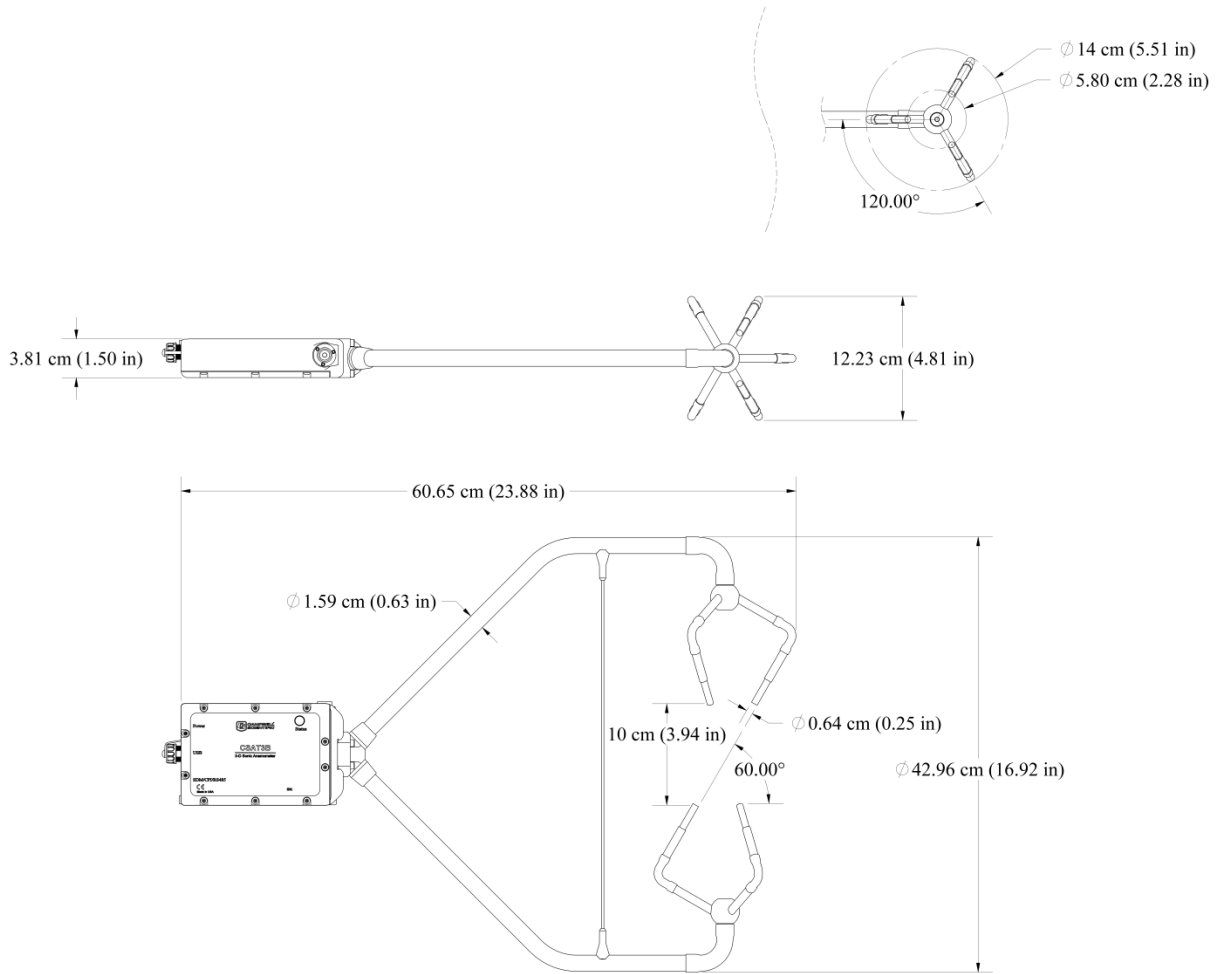

FIGURE 6-1. Dimensions of CSAT3B

7. Installation

Campbell Scientific recommends that the CSAT3B and data acquisition system is setup in a laboratory setting before field installation. This provides an opportunity to verify that settings and programs are correct in a controlled environment. Prior to setup, the user needs to know information about the desired sensor settings, orienting, mounting, and leveling the CSAT3B, which is covered in the following sections.

7.1 Settings

Prior to installation, the CSAT3B's settings should be verified. This is done by the following steps:

1. Provide power to the CSAT3B by connecting the M16 connector of either a CSAT3BCBL1 or CSAT3BCBL2 to the **Power/SDM** port on the back of the CSAT3B block. The other end of this cable will have red and black wire leads that should be connected to a 9.5 to 32 Vdc power source. (In the case of the CSAT3BCBL1, the other wire leads need not be connected.)

2. Connect the circular connector on the USB data cable included with the CSAT3B (pn 30179) to the port labelled **USB** on the back of the CSAT3B block. Connect the other end of the cable to a USB port on a PC.
3. Launch *Device Configuration Utility* (available on the included resource DVD or downloaded from www.campbellsci.com).
4. From the left side of the main screen, select the CSAT3B among the list of sensors. Select the appropriate communication port and baud rate (refer to the left side of FIGURE 7-1).
5. If this is the first time this PC has connected to a CSAT3B and depending on the PC settings, the USB driver may need to be manually installed. To do this, make sure the PC is connected to the internet and click on the **install the USB driver** link as shown in FIGURE 7-1).
6. Once the driver has been installed, if needed, press the **Connect** button at the bottom left of the window.

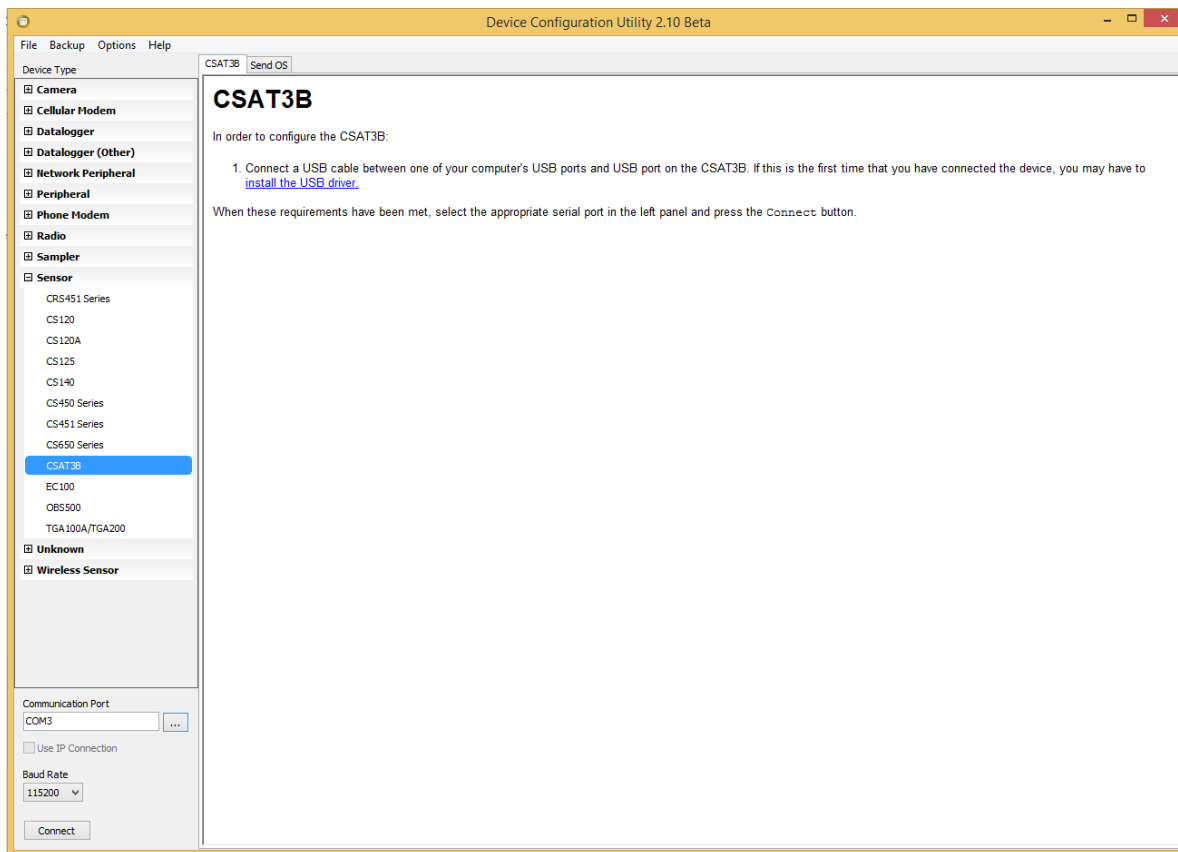

FIGURE 7-1. Connecting CSAT3B using Device Configuration Utility

7. Once connected, the main screen will have a section with tabs to view the following four subscreens: *Real-Time Data*, *Communication Settings*, *Measurement Settings*, and *Instrument ID*. TABLE 7-1

describes each of the settings or status values in these subscreens. For each setting or status value, the factory default setting is noted by the footnote. Ensure that the appropriate settings are enabled for the communication protocol that will be used. An example subscreen is shown in FIGURE 7-2.

TABLE 7-1. CSAT3B Settings and Status Values in *Device Configuration Utility*

Subscreen	Setting or Status Value	Options	Description
<i>Real-Time Data</i>	Anemometer Data	-	Shows real-time measurements of U _x , U _y , U _z , sonic temperature (T _s), and the diagnostic word. If in operating Mode 1 (see Section 8.2, <i>Operating Mode</i>), values will flash each second.
	Internal Temperature	-	Temperature inside CSAT3B block
	Internal Relative Humidity	-	Relative humidity inside CSAT3B block. Change desiccant if greater than 50% (see Section 9.3, <i>Desiccant</i>).
	Inclinometer Pitch	-	Pitch angle of CSAT3B head (see Section 7.3, <i>Mounting</i>)
	Inclinometer Roll	-	Roll angle of CSAT3B head (see Section 7.3, <i>Mounting</i>)
<i>Communication Settings</i>	SDM Address	1 through 14 3 ¹	Unique address for SDM device
	CPI Address	1 through 120 30 ¹	Unique address for CPI device
	Communication Port Protocol	Disable Both CPI Enabled ¹ RS-485 Enabled	Identifies whether the RS-485/CPI port will be disabled, enabled for CPI, or enabled for RS-485
	CPI Baud Rate	Auto ¹ 1000 kbps 500 kbps 250 kbps 125 kbps 50 kbps	Baud rate for CPI communications (in most circumstances this setting should remain set to Auto)
	RS-485 Baud Rate	1200 2400 4800 9600 19200 38400 57600 115200 ¹ 230400	Baud rate for RS-485 communications
	Unprompted Output Port	Disabled ¹ USB Port RS-485 Port	Identifies the port to output unprompted data

TABLE 7-1. CSAT3B Settings and Status Values in *Device Configuration Utility*

Subscreen	Setting or Status Value	Options	Description
	Unprompted Output Rate	10 Hz ¹ 20 Hz 50 Hz 100 Hz	Identifies the rate at which to output unprompted data
<i>Measurement Settings</i>	Operating Mode	Mode 1: Datalogger-triggered No filter Datalogger-prompted output ¹ Mode 2: Self-triggered Filtered Datalogger-prompted output Mode 3: Self-triggered No filter Unprompted output to PC Mode 4: Self-triggered Filtered Unprompted output to PC	Identifies the source of the measurement trigger, whether a low pass filter will be applied, and the output mode (see section 8.2 for more details on operating mode)
	Filter Bandwidth	5 Hz 10 Hz 20 Hz 25 Hz	The cut-off frequency of the low pass filter
<i>Instrument ID</i>	Anemometer Serial Number	Serial Number ¹	The serial number of the CSAT3B
	User ID String	Blank ¹	A unique identifier in addition to the serial number that the user may assign
	Factory ID String	Blank ¹	A unique identifier in addition to the serial number that the factory may assign
	OS Version	-	The version number of the CSAT3B operating system
	OS Date	-	The date the loaded operating system was built

¹ Denotes a factory default setting

NOTE Factory defaults for all setting may be restored by clicking the **Factory Defaults** button at the bottom of the screen in the *Device Configuration Utility*.

NOTE The SDM communications port is always enabled.

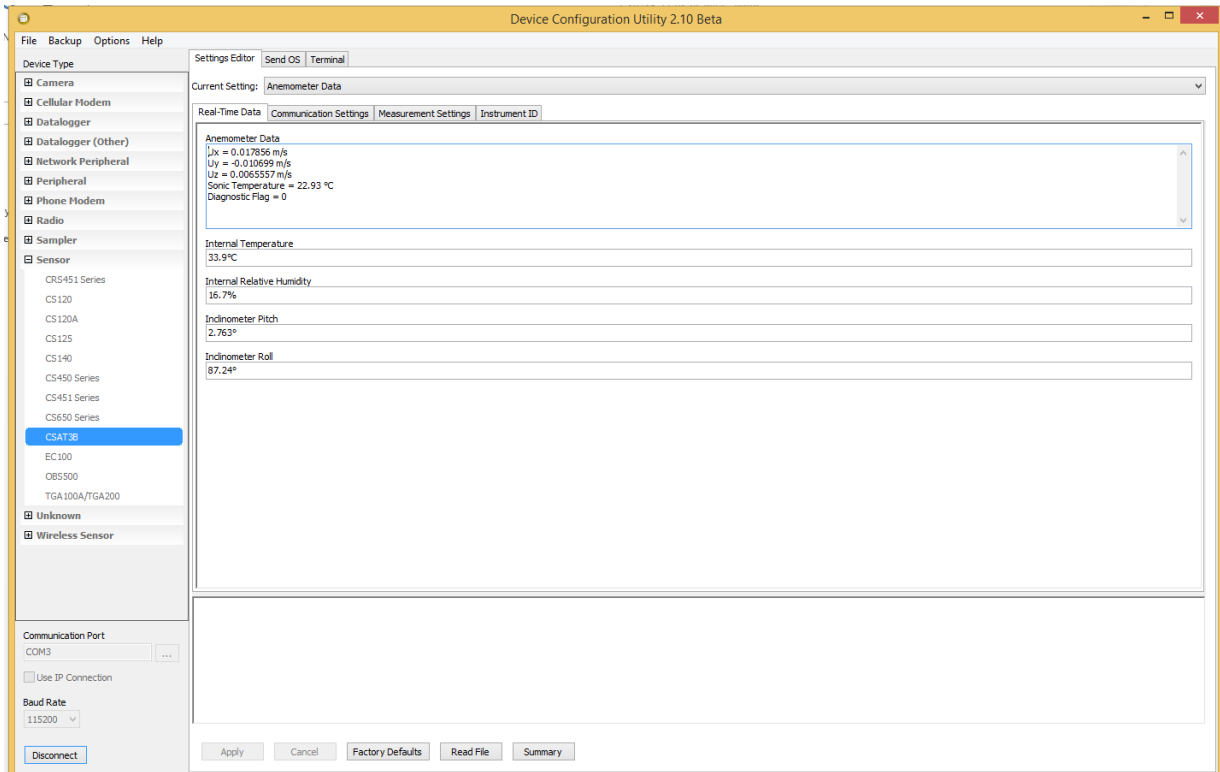

FIGURE 7-2. Real-time data subscreen while connected to CSAT3B with Device Configuration Utility

7.2 Orientation

The three components of wind are defined by a right-handed orthogonal coordinate system. The CSAT3B points into the negative x direction (see FIGURE 7-5). If the anemometer is pointing into the wind, it will report a positive u_x wind.

In general, the anemometer should be pointed into the prevailing wind to minimize interference from support structures such as the tower or tripod. Typically, the anemometer should be mounted level to the ground as described in Section 7.4, *Leveling*.

7.3 Mounting

The CSAT3B is supplied with mounting hardware to attach it to the end of a horizontal pipe with an outer diameter of 3.33 cm (1.31 in), such as the Campbell Scientific CM202, CM204, or CM206 crossarm (referred to generically as a CM20X crossarm). The following steps describe the normal mounting procedure.

1. Secure the chosen crossarm to a tripod or other vertical structure using a CM210 crossarm-to-pole mounting kit (pn 17767) as shown in FIGURE 7-3.

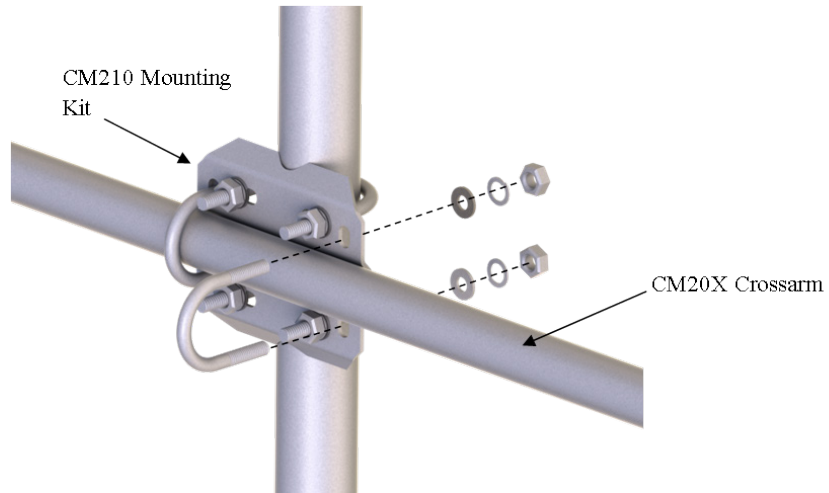

FIGURE 7-3. CM210 mounting kit with CM20X crossarm

2. Point the horizontal arm into the direction of the prevailing wind and tighten the nuts and bolts of the mounting hardware.
3. Attach the CM250 leveling mount (pn 26559; included with the CSAT3B) to the crossarm by tightening the set screws on the boom adapter with a 3/16-in hex socket head wrench. Refer to FIGURE 7-4.
4. Attach the CSAT3B to the leveling mount by inserting the bolt on the mount into the threaded hole on the bottom of the CSAT3B block as shown in FIGURE 7-4.
5. Lightly tighten the bolt and then proceed to the leveling steps.

CAUTION Do not carry the CSAT3B by the arms or the strut between the arms. Always hold the CSAT3B by the block, where the upper and lower arms connect.

CAUTION Over-tightening bolts will damage the screw threads in the CSAT3B block.

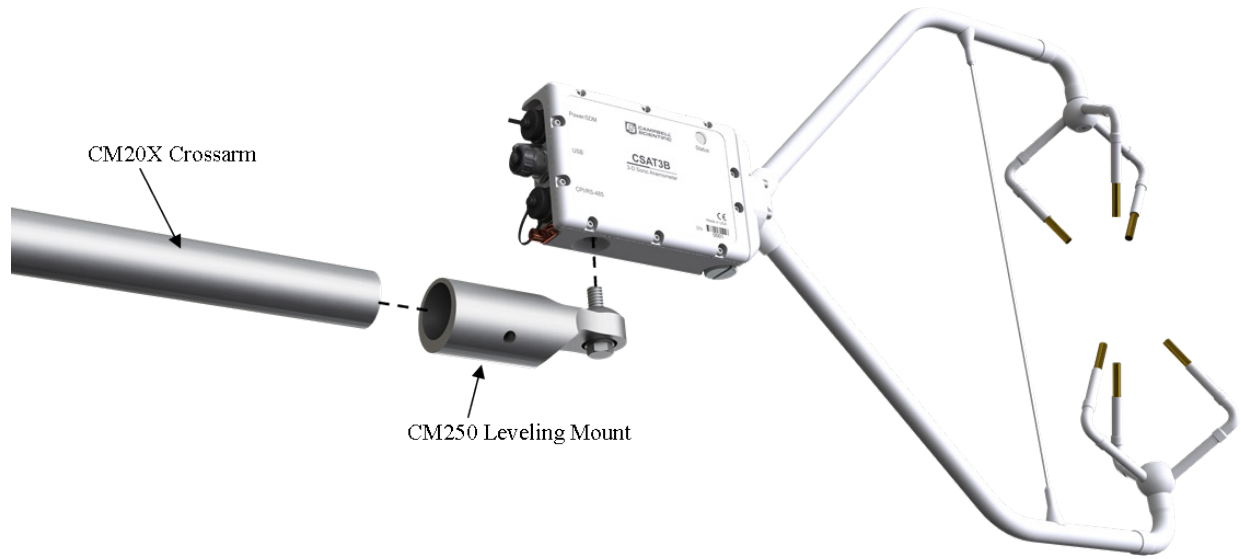

FIGURE 7-4. CSAT3B mounting

7.4 Leveling

Leveling the CSAT3B within a couple degrees is usually sufficient. The user commonly applies coordinate rotations to time-series data to report the three-dimensional wind in a coordinate system where the x- and y-axis lie along the stream wise wind plane.

Over level terrain, adjust the anemometer head so that the bubble within the level on top of the CSAT3B block is in the bullseye.

Over sloping terrain, adjust the anemometer head so that the horizontal surface upon which the bubble level is mounted is parallel to the terrain. Firmly grasp the sonic anemometer block, loosen the bolt underneath the block, and adjust the head accordingly. Finally, tighten the bolt with a 9/16-in wrench.

If an application requires greater accuracy in inclination of the CSAT3B, or if an application requires a measurement that shows if, and when, the inclination of the CSAT3B changes over time (for example, a sagging crossarm or tower tilt), an integrated inclinometer in the CSAT3B can give pitch and roll measurements.

Pitch is the rotation about the CSAT3B y-axis and is given by the smallest angle between the CSAT3B x-axis (see FIGURE 7-5) and a horizontal plane. A positive pitch angle corresponds to a clock-wise rotation about the y-axis when looking down on the y-axis. In other words, a positive pitch angle occurs when the transducer end of the CSAT3B is pointed downwards, while a negative pitch angle occurs when CSAT3B is pointed upwards.

Roll is the rotation about the CSAT3B x-axis, and is given by the angle between the CSAT3B z-axis and an imaginary axis that is normal to the gravitationally level plane. A positive roll angle corresponds to a counter-clockwise rotation about the x-axis when looking down the x-axis.

The inclinometer is sampled at a rate of 2 Hz and is not necessarily synchronized with the wind and sonic temperature data outputs. For applications that require correction for a moving measurement platform (on a buoy or ship, for example), a separate fast-response inclinometer, gyrometer, and accelerometer sensor should be used and sampled at the same rate as the CSAT3B wind measurements.

The outputs of the CSAT3B integrated inclinometer can be viewed by connecting the USB data cable (pn 30179) to the CSAT3B and a PC computer running Campbell Scientific's *Device Configuration Utility*. It can also be output using the CRBasic instruction CSAT3BMonitor. See Section 8.4.1.2, *CSAT3BMonitor()*, for more information about setting this instruction.

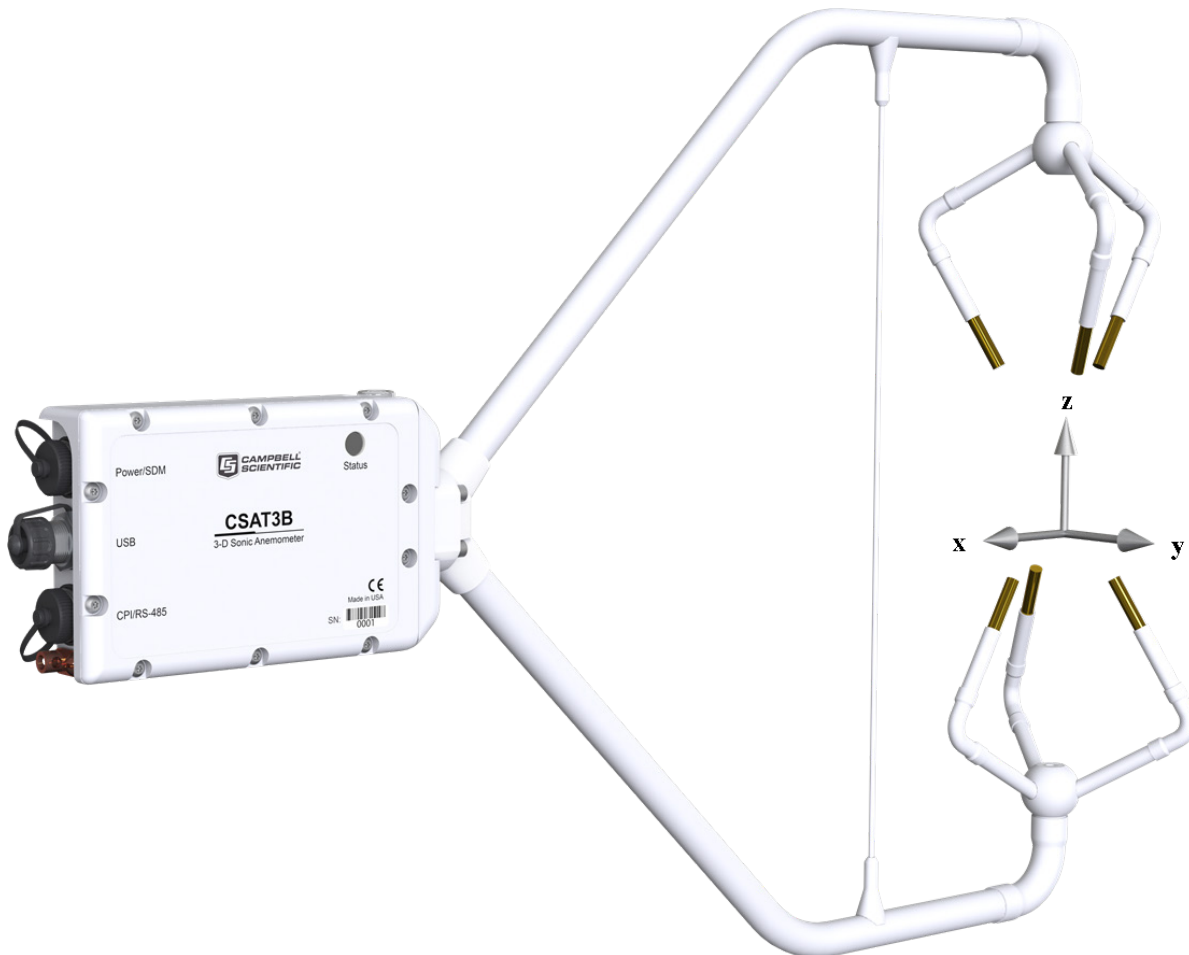

FIGURE 7-5. CSAT3B shown with coordinate system, with arrows representing positive x, y, and z axes

7.5 Additional Fast-response Sensors

7.5.1 Fine-Wire Thermocouple

A fine-wire thermocouple (model FW05 with a FWC-L cable, TC cover, and TC cover backplate) can be mounted to the side of the anemometer block to measure temperature fluctuations.

First, attach the TC cover backplate to the CSAT3B with the screw that was included. Next, attach the female connector from the FWC-L to the side of the anemometer with the short screw (#2-56 x 0.437in, pn 3514) that was provided with the white thermocouple cover (pn 10080). Insert the male connector of the FW05 into the female connector of the FWC-L. Finally, attach the thermocouple cover to the anemometer block using the thumb screw so that both the FW05 and FWC-L connectors are covered. See FIGURE 7-6 for positioning and FIGURE 7-7 with the FW05 fully installed.

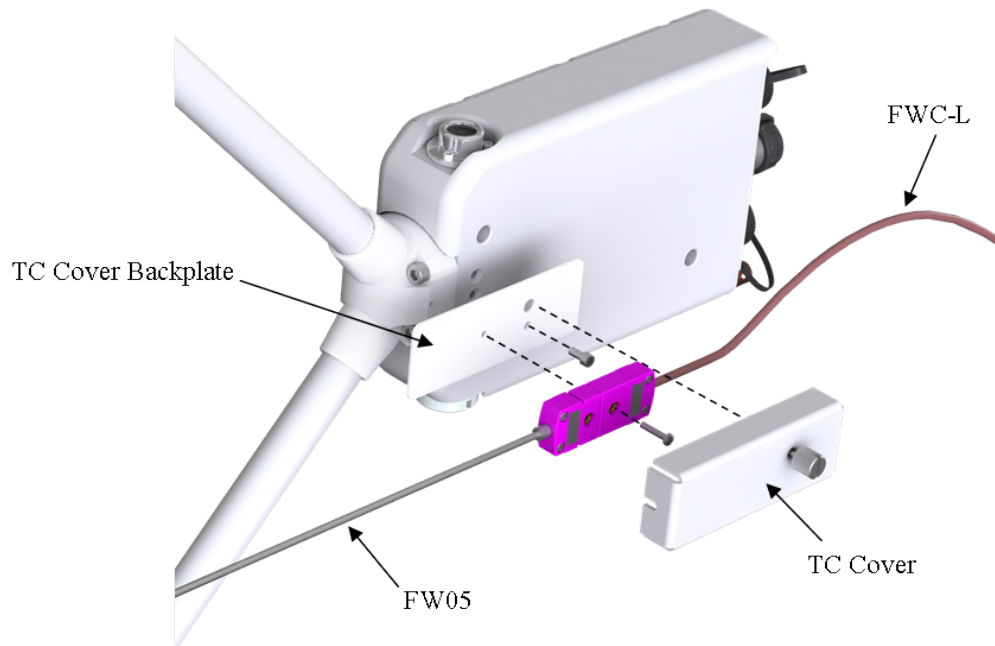

FIGURE 7-6. Exploded view of fine-wire thermocouple with CSAT3B

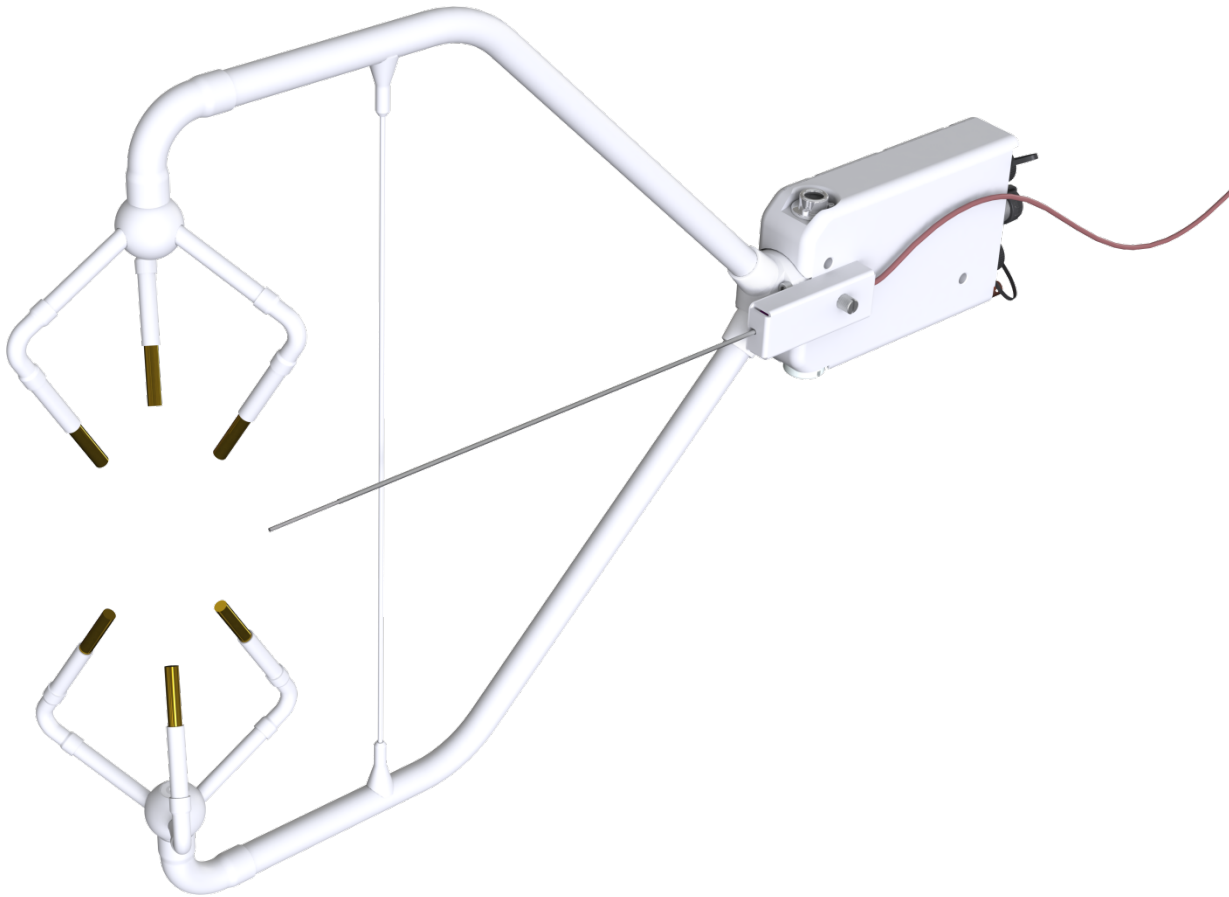

FIGURE 7-7. CSAT3B with fine-wire thermocouple mounted

7.5.2 Other Gas Analyzers

If a fast-response gas analyzer is being used with the CSAT3B, care should be taken to mount the analyzer (open-path) or the analyzer intake (closed-path) as close as possible to the sonic sampling volume in order to obtain good spatial and temporal synchronicity between vertical wind and gas concentration fluctuations while also retaining adequate spatial separation. This will avoid excessive wind distortion. In general, mount the analyzer or its intake downwind of the sonic sampling volume.

7.6 Wiring

On the back of the CSAT3B block there is a copper grounding lug (refer to FIGURE 4-3). Use a standard flat-head screwdriver to pinch an 8 AWG to 14 AWG wire between the lug and the lug screw. Campbell Scientific offers a 10 AWG copper wire (pn 4335) that is suitable for grounding sensors. Connect the other end of the wire to the tripod or tower, which should be grounded to Earth.

The CSAT3B has three watertight circular ports or connectors at the rear of the block. These are labeled **Power/SDM**, **USB**, and **CPI/RS-485** as shown in FIGURE 4-3. Unless a port is in use and connected to a cable, they should be securely covered by one of the caps that are captive to the CSAT3B.

The appropriate port and cable type to be used are determined by the chosen communication method. TABLE 7-2 shows some of the criteria to use when determining the best communication method for a given application. Once a suitable method is determined, the appropriate combination of cables, connectors, and lengths should be used (see Section 5.2.3.1, *Power and Communications Cables*, for information about ordering cables).

If the CSAT3B is going to be operated using SDM or CPI communications where the datalogger triggers the measurement and the data are unfiltered (see Mode 1 in Section 8.2, *Operating Modes*), then the CSAT3B default settings are appropriate and do not require modification. If, however, the CSAT3B will be operated in another mode that either requires data filters or uses USB or RS-485 communications, the settings must be modifying as described in Section 7.1, *Settings*.

NOTE Unlike previous CSAT3 models, the CSAT3B does not include 7.6 m (25 ft) lengths of all cable types. Only the 5 m (16 ft) USB cable for initial configuration of the sensor is included. Other cables must be ordered separately.

TABLE 7-2. Summary of Communications Options for the CSAT3B

	SDM	USB	CPI	RS-485
Data collection	Dataloggers: <ul style="list-style-type: none"> • CR800 • CR1000 • CR3000 	PC	Dataloggers: <ul style="list-style-type: none"> • CR6 • CR800¹ • CR1000¹ • CR3000¹ 	PC
Cable length	Medium	Short, < 5 m	Longest	Long
Required cables	CSAT3BCBL1	CSAT3BCBL2 and USB cable (included)	CSAT3BCBL2 and CSAT3BCBL3	CSAT3BCBL2 and CSAT3BCBL3
Robustness	Better	Worse	Best	Better
Bandwidth	OK	Best	Best	OK
Synchronization with other sensors	Best	Worse	Best	Worse
Noisy environments	OK	OK	Best	Better

¹ Requires using the SC-CPI Interface

7.7 Communications

There are many possible configurations of multiple CSAT3Bs and other sensors on a single measurement station or system. Accordingly, power requirements and sensor cable lengths should be taken into account to appropriately power all sensors and avoid excess attenuation of signals. The following sections describe different types of communications and different configurations that may be helpful when designing the layout and configuration of a system. For additional help, contact a Campbell Scientific application engineer.

NOTE For all communications types, if the total number of CSAT3Bs and other sensors powered by the datalogger exceeds the limit of output current from the datalogger, the power wires must be connected to a separate 12 to 32 Vdc power supply. For long cables, a higher voltage power supply is recommended as there will be voltage loss over long distances.

WARNING **Not all of the dataloggers that are compatible with the CSAT3B support the same voltage input range as the CSAT3B. While the CSAT3B supports voltage of up to 32 Vdc, many dataloggers require lower voltage. For example, the CR800, CR1000, and CR3000 require 9.6 to 16 Vdc when connecting to the front panel voltage input. If a CR3000 has a rechargeable base, then a 17 to 28 Vdc power supply may be connected to the base. Unlike most of the dataloggers, the CR6 does support up to 32 Vdc if the power supply is connected to the CHG input terminals. For more details, refer to a datalogger user manual.**

7.7.1 SDM Communications

If data collection from the anemometer is to be accomplished using a datalogger with SDM communications, connect a CSAT3BCBL1 to the **Power/SDM** port by screwing in the M16 connector into the port until tight as shown in FIGURE 7-8. No other cables are required for SDM communications, as the CSAT3BCBL1 contains both power and SDM wiring.

If only one CSAT3B is being measured, the opposite end of the cable will have wire pigtails if connecting directly to the ports on a datalogger. Refer to Section 4.2, *Communications Connections*, for this wiring. Connect the white, yellow, and blue wires to the **SDM-C1**, **SDM-C2**, and **SDM-C3** ports respectively, on a datalogger (FIGURE 7-9). On a datalogger or to another 9.5 to 32 Vdc power supply, connect the red and black wires to the **12 V** and **G** ports, respectively. See FIGURE 7-9 and TABLE 7-3 for wiring and wire color designations.

For applications requiring very long cable lengths, a higher voltage power supply is recommended as voltage drop over long distances will occur and the CSAT3B requires a minimum of 9.5 Vdc.

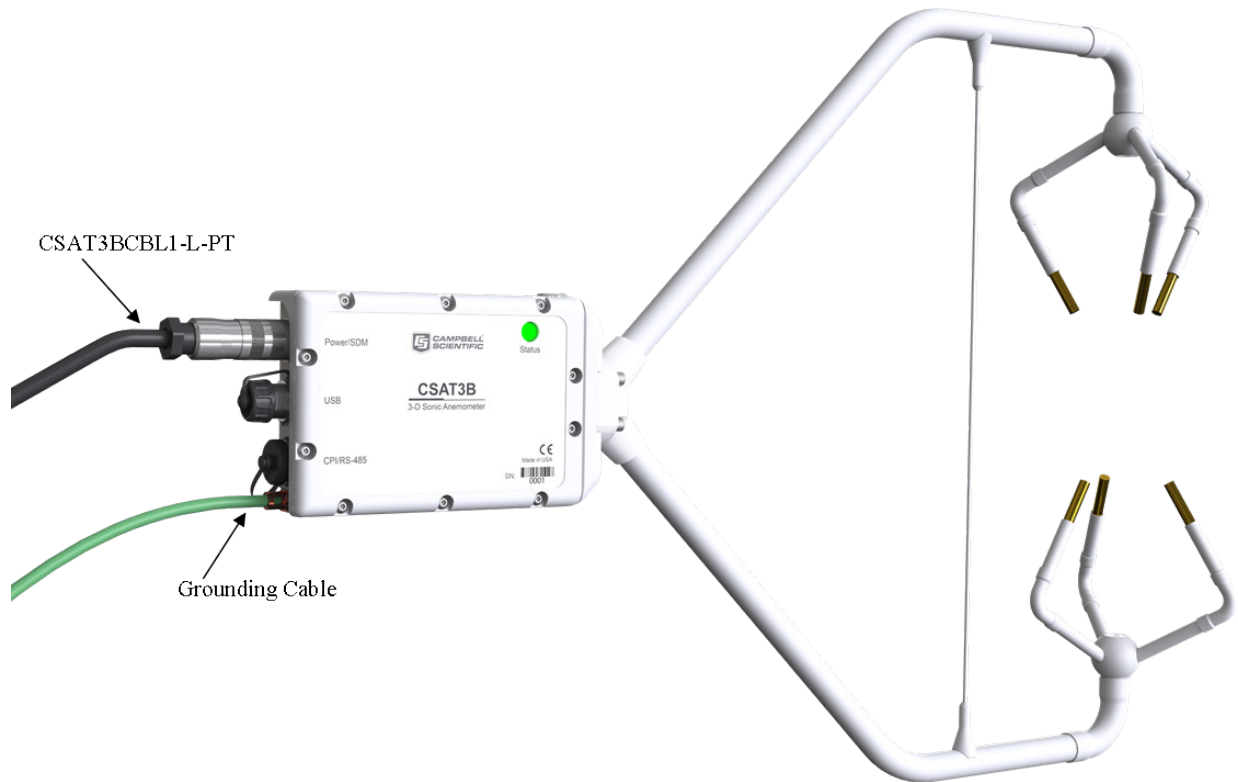

FIGURE 7-8. SDM/Power connections

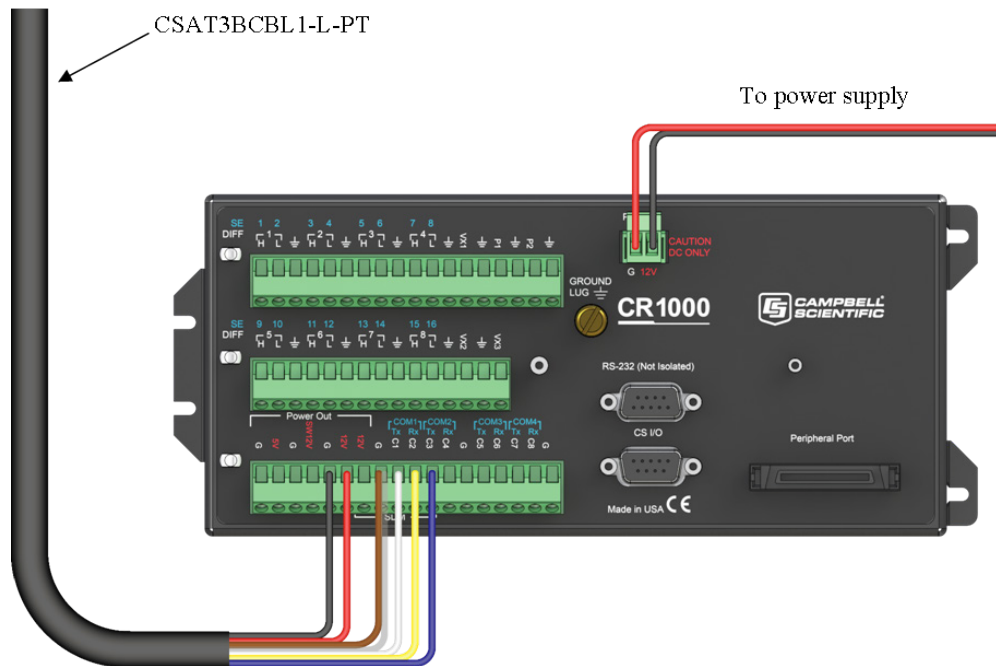

FIGURE 7-9. Wiring to power and SDM ports on CR1000 datalogger

For an application that requires SDM communications from multiple CSAT3Bs in series, or with a daisy-chain topology, first connect to each CSAT3B as described in Section 7.1, *Settings*, to ensure each sensor has been assigned a unique SDM address. Connect a CSAT3BCBL1 to the **Power/SDM** port of the terminal CSAT3B. The opposite end will have an M16 connector that mates with one of the split M16 connectors on the Power/SDM splitters (pn 30293). Next, screw the side of the splitter with only one M16 connector to the **Power/SDM** port of the second CSAT3B. Connect another CSAT3BCBL1 to the splitter and down to the next CSAT3B. Continue the daisy-chain until the last CSAT3B. The final CSAT3BCBL1 should have pigtail wire ends to connect to the **SDM** and **12 V** ports of a datalogger.

If several CSAT3Bs using SDM communications are being connected in parallel or with a star topology, connect a CSAT3BCBL1 cable to the **Power/SDM** port of each CSAT3B, and connect the other wire leads on the pigtail end of the cables to a HUB-SDM8 bus (see Section 5.2.4.3, *HUB-SDM8*).

Connect the wires so that all wires of a common color or signal are on the same rail. Then, use a CABLE5CBL with pigtail wire leads to connect the HUB-SDM to the **SDM** and **12 V** ports of a datalogger.

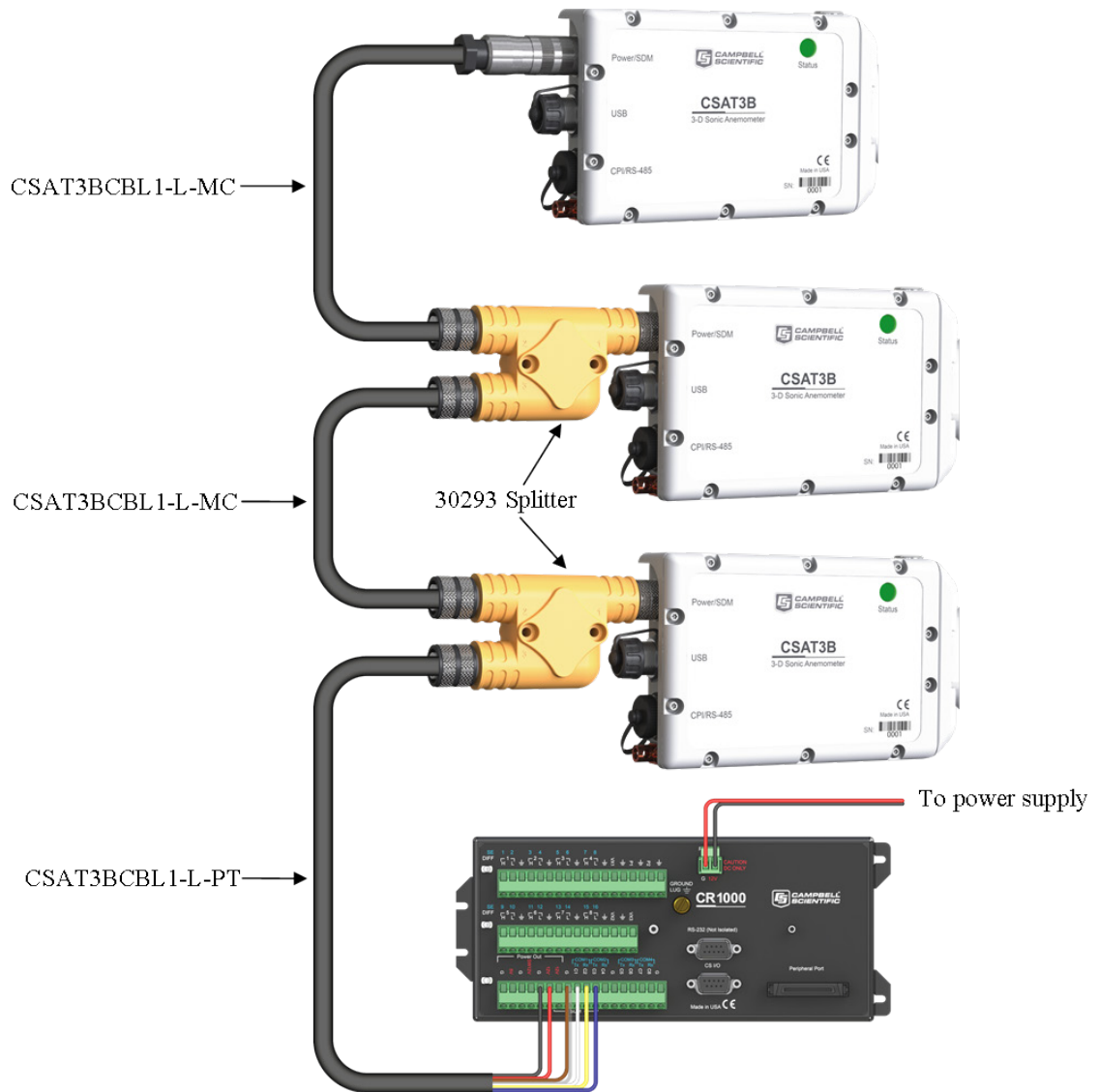

FIGURE 7-10. SDM daisy chain (CSAT3B sensor arms and grounding cables not shown)

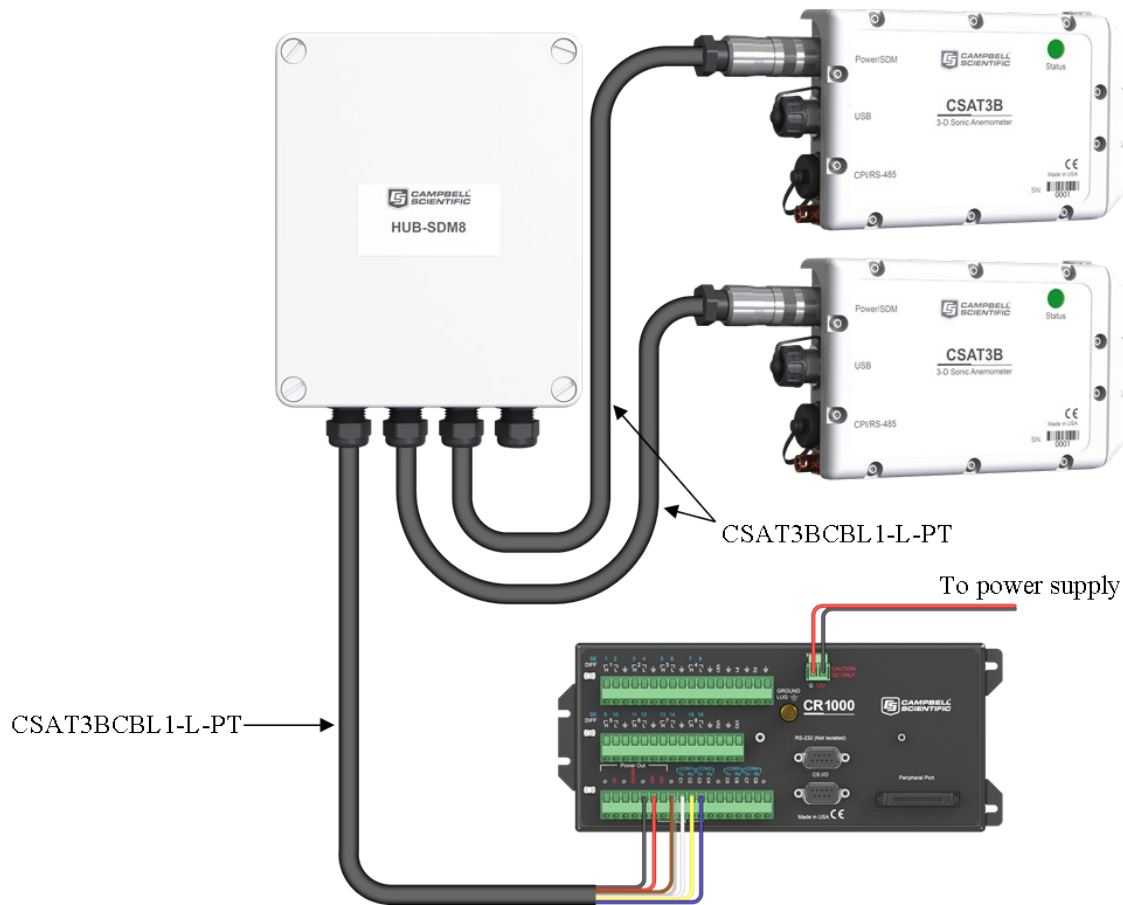

FIGURE 7-11. SDM star topology (CSAT3B sensors arms and grounding cables not shown)

7.7.2 CPI Communications

If data collection from the anemometer is to be done by a datalogger using CPI communications, then connect a CSAT3BCBL2 to the **Power/SDM** port by screwing in the M16 connector into the port until tight.

NOTE

A CSAT3BCBL1 may also be used for power, but the SDM wires will not be used. The CSAT3BCSBL1 also has lighter gauge power wires, which increases voltage loss over long cable length, so it should only be used for shorter cable lengths.

Next, connect a CSAT3BCBL3 to the **CPI/RS-485** port in the same manner. If only one CSAT3B is being measured, the opposite end of the power cable should have pigtail wire leads which may be wired to the **12 V** and **G** terminals on a datalogger or to another 12 to 32 Vdc power supply. The CPI cable should have the RJ-45 connector plugged into the CPI port of the datalogger.

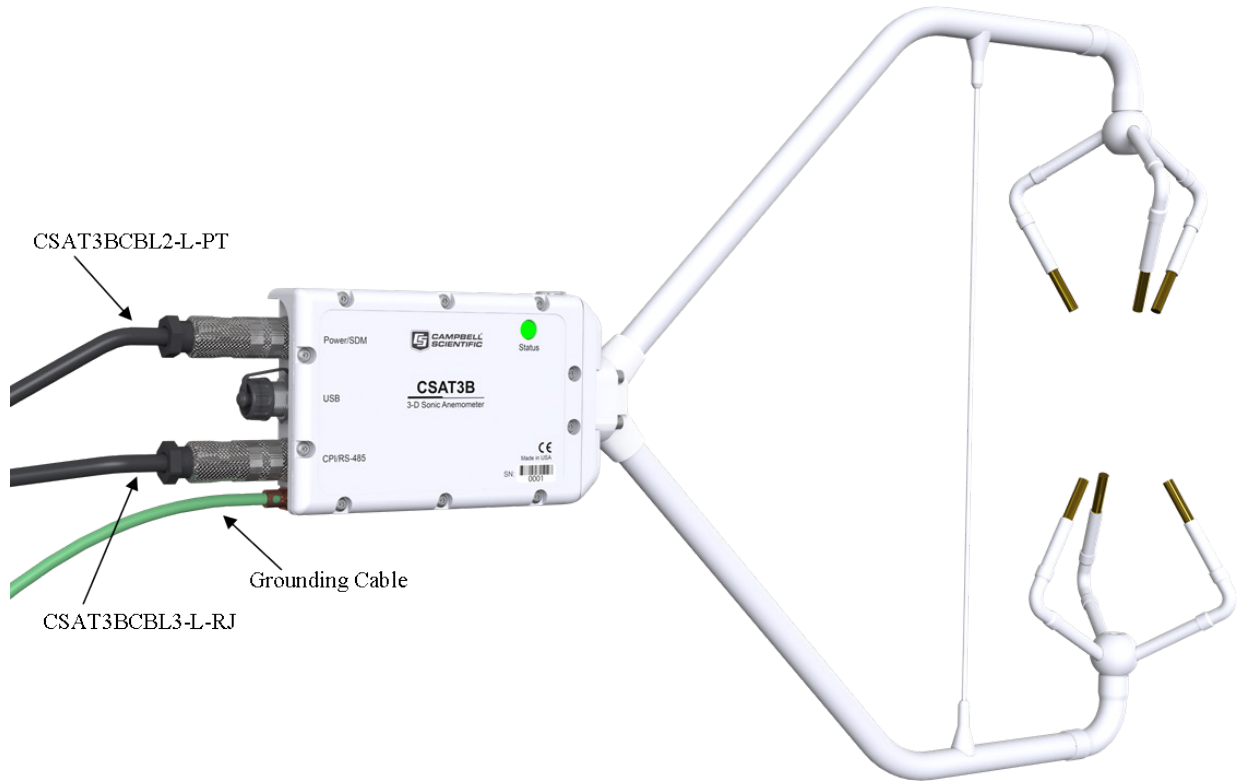

FIGURE 7-12. Power and CPI cable connections

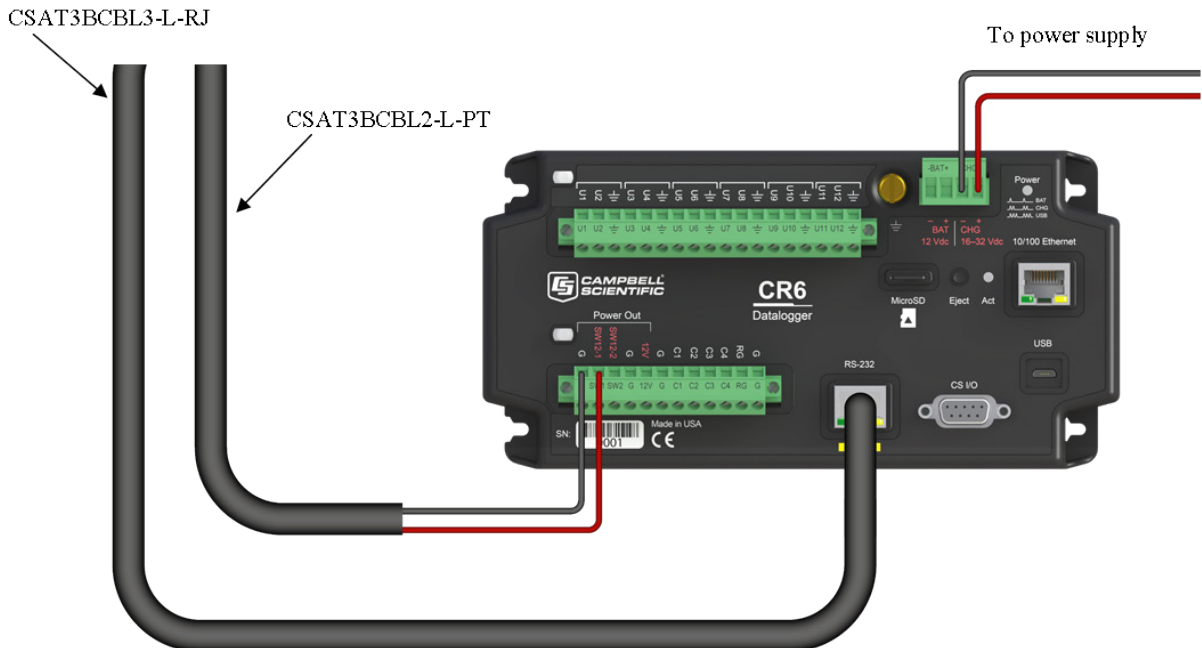

FIGURE 7-13. CPI connection to a CR6 datalogger

CPI Daisy-chain Topology

For an application that requires CPI communication from multiple CSAT3Bs in series, or with a daisy-chain topology, first connect to each CSAT3B as described in Section 7.1, *Settings*, to give each sensor a unique CPI address. Then connect a CSAT3BCBL2 to the **Power/SDM** port and a CSAT3BCBL3 to the **CPI/RS-485** port on the terminal CSAT3B. The opposite end of the power cable should use an M16 connector to mate with one of the split M16 connectors on the power/SDM splitter (pn 30293). The opposite end of the CPI cable should use an M16 connector to mate with one of the split M16 connectors on the CPI/RS-485 splitter (pn 30294).

Screw the side of the splitters with only one M16 connector to the **Power/SDM** and **CPI/RS-485** ports of the second CSAT3B. Connect another set of cables from these splitters down to the next CSAT3B. Continue the daisy-chain until the last CSAT3B, where a final CSAT3BCBL2 should have pigtail wire ends to connect to the **12 V** and **G** ports of a datalogger or to a 12 to 32 Vdc power supply. The final CSAT3BCBL3 should have an RJ-45 connector that plugs into the CPI port of the datalogger. Refer to FIGURE 7-14 for the described connections.

CPI Star Topology

If several CSAT3Bs using CPI communications are being connected in parallel or with a star topology, connect a CSAT3BCBL2 cable to each **Power/SDM** port of each CSAT3B, and connect the other wire leads to the **12 V** and **G** ports of a datalogger or to another 12 to 32 Vdc power supply (for convenience, it's possible to use a wiring bus such as the HUB-SDM8 to bring several power wires together and then extend a single cable such as the CABLEPCBL-L from the bus to the power supply).

Connect a CSAT3BCBL3 to each **CPI/RS-485** port of each CSAT3B, and connect the opposite end, which should have RJ-45 connectors to a HUB-CPI. Then, use a CAT5e or CAT6 Ethernet cable to connect the HUB-CPI to the CPI port of a datalogger. Refer to FIGURE 7-15 for these connections.

NOTE

The sockets or ports on the HUB-CPI are all the same. It does not matter which socket is used to connect to the datalogger or to other CSAT3Bs.

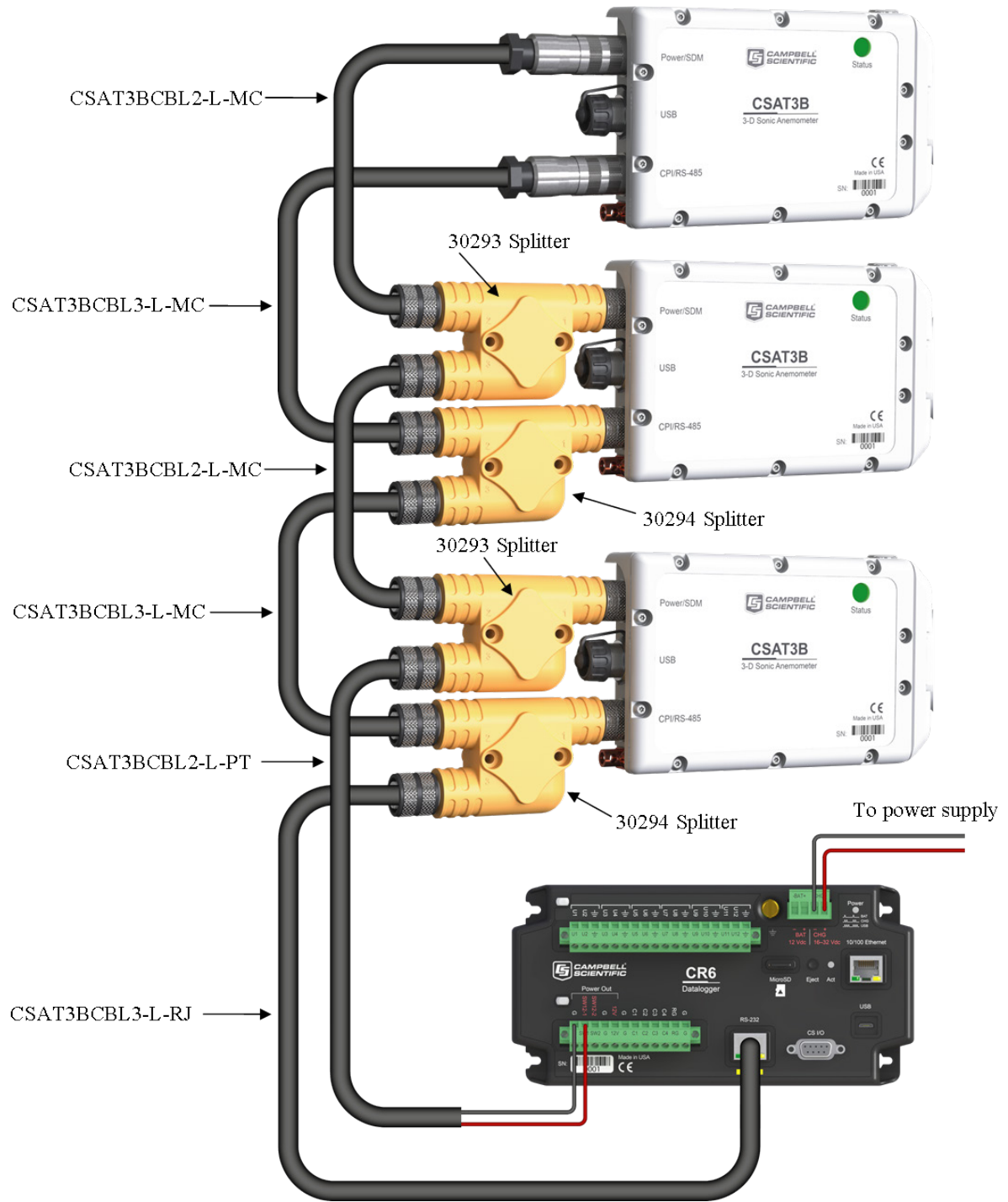

FIGURE 7-14. CPI daisy chain (CSAT3B sensor arms and grounding cables not shown)

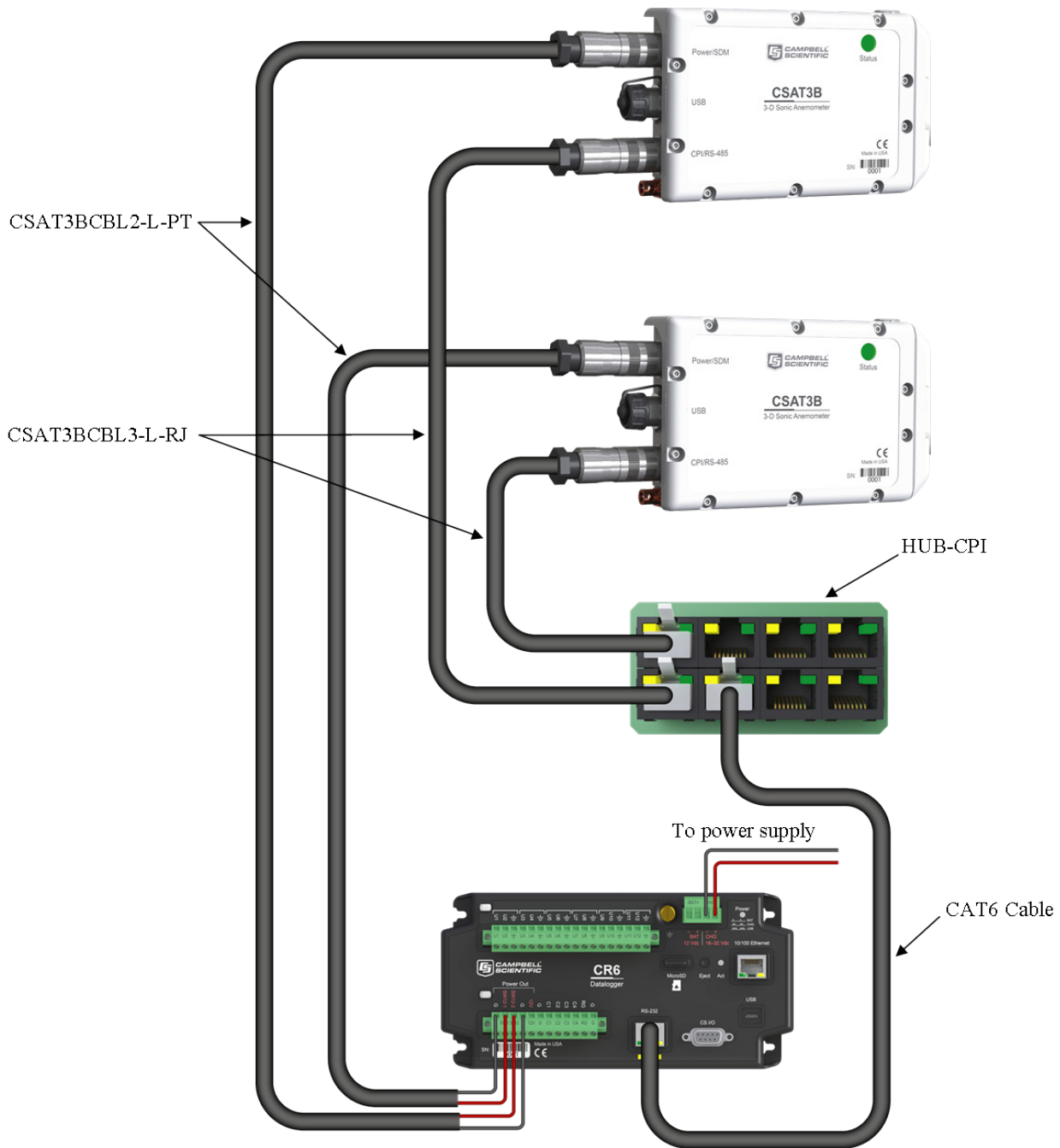

FIGURE 7-15. CPI star topology (CSAT3B sensor arms and grounding cables not shown)

7.7.3 RS-485 Communications

If data collection from the anemometer is to be accomplished by a PC using RS-485, first connect the CSAT3B as described in Section 7.1, *Settings*, to confirm the following settings:

CPI/RS-485 Communication Port Protocol: RS-485 Enabled

RS-485 Baud Rate: 115200 or other appropriate value

Unprompted Output Port: RS-485 Port

Unprompted Output Rate: 10, 20, 50 or 100 Hz

Operating Mode:

- Mode 3: Self-triggered | No filter | Unprompted output to PC, or
- Mode 4: Self-triggered | Filtered | Unprompted output to PC (If Mode 4, select filter bandwidth.)

To complete installation, connect a CSAT3BCBL2 to the **Power/SDM** port by screwing in the M16 connector into the port until tight.

NOTE

A CSAT3BCBL1 may also be used for power, but the SDM wires will not be used. The CSAT3BCSBL1 also has lighter gauge power wires, which increases voltage losses over long cable length, so it should only be used for shorter cable lengths.

Next, connect a CSAT3BCBL3 cable to the **CPI/RS-485** port in the same manner. If only one CSAT3B is being measured, the opposite end of the power cable should have pigtail wire leads, which may be connected to a 12 to 32 Vdc power supply, and the RS-485 cable should have pigtail wire leads for wiring to a connector on a PC (see FIGURE 7-16). Refer to TABLE 7-2 for a summary of the receive-and-transmit wiring.

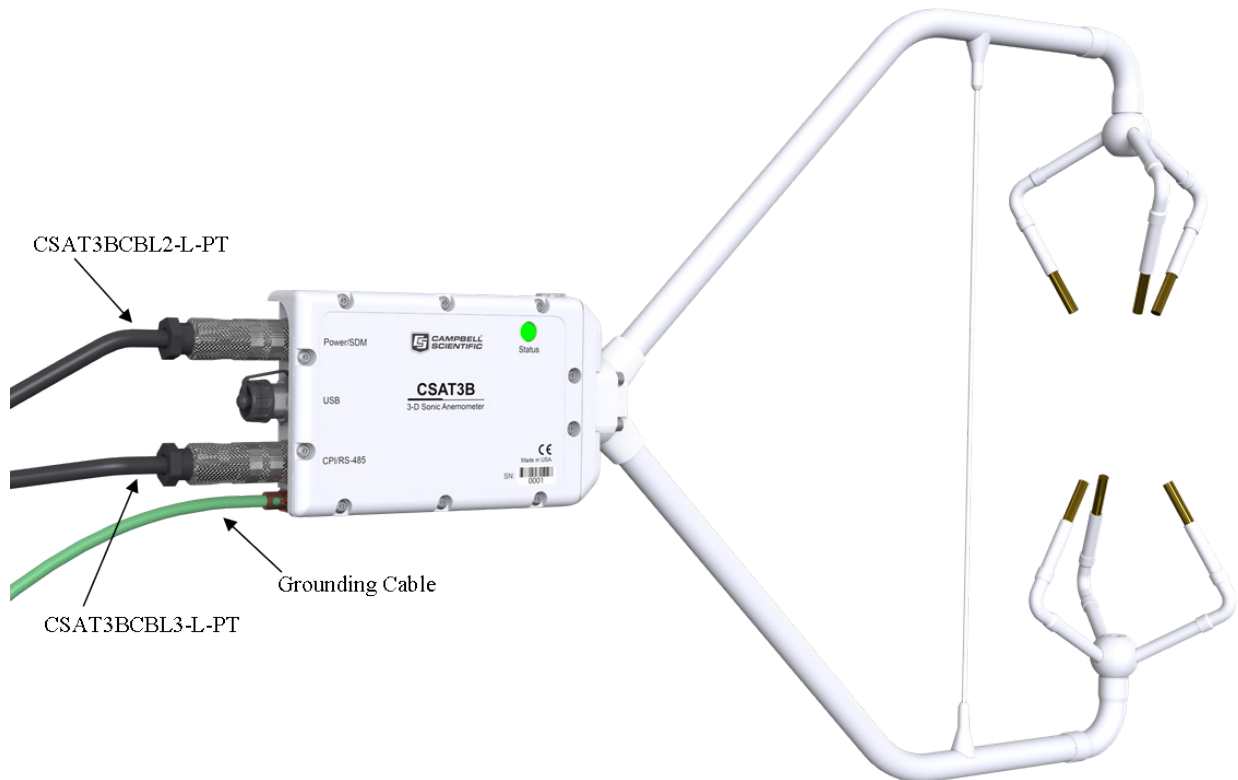

FIGURE 7-16. RS-485 cable connections

7.7.4 USB

If data collection from the anemometer is to be done by a PC using USB communications, first connect to the CSAT3B as described in Section 7.1, *Settings*, to confirm the following settings:

Unprompted Output Port: USB Port

Unprompted Output Rate: 10, 20, 50 or 100 Hz

Operating Mode:

- Mode 3: Self-triggered | No filter | Unprompted output to PC
or
- Mode 4: Self-triggered | Filtered | Unprompted output to PC (If Mode 4, select filter bandwidth.)

To complete installation, connect a CSAT3BCBL2 to the **Power/SDM** port by screwing in the M16 connector into the port until tight.

NOTE

A CSAT3BCBL1 may also be used for power, but the SDM wires will not be used. The CSAT3BCSBL1 also has lighter gauge power wires, which increases voltage losses over long cable length, so it should only be used for shorter cable lengths.

Connect the 5 m (16 ft) USB cable included with the CSAT3B to the USB port in the same way. If only one CSAT3B is being measured, the opposite end of the power cable should have pigtail wire leads, which may be connected to a 12 to 32 Vdc power supply, and the USB cable should be connected to a USB port on a PC.

For a watertight connection to the USB port, use the included USB cable (pn 30179). For a temporary, non-watertight connection to the USB port, any USB male A type to male Mini-B type cable can be used.

WARNING

Unused ports on the CSAT3B block should always have the caps securely screwed on to avoid water damage to the electronics.

TABLE 7-3. CSAT3B Cable Wire Assignments

CSAT3B Cable Type	Signal Description	Pigtail Color	Connector Pin #
CSAT3BCBL1	Power 9.5-32 Vdc	Red	1
	Ground	Black	2
	SDM GND	Brown	3
	SDM C1	White	4
	SDM C2	Yellow	5
	SDM C3	Blue	6
	Shield	Clear	Shell
CSAT3BCBL2	Power 9.5-32 Vdc	Red	1
	Ground	Black	2
CSAT3BCBL3	RxA	Brown	4
	RxB	Brown stripe	2
	TxA	Blue	6
	TxB	Blue stripe	1
	RGND	Green	5

If a fine-wire thermocouple such as a model FW05 with FWC-L is being used, the wiring designations in TABLE 7-4 should be followed to connect the thermocouple to a differential voltage channel on a datalogger.

TABLE 7-4. FW05/FWC-L Fine-Wire Thermocouple

Description	Color
Signal high	Purple
Signal low	Red

8. Operation

8.1 Theory of Operation

The CSAT3B uses three pairs of non-orthogonally oriented transducers that transmit and receive ultrasonic signals. The time of flight of a sonic signal between a pair of transducers is directly related to the wind vector component that is parallel to the sonic axis. The CSAT3B is able to calculate the wind vector components along each sonic axis using the time difference between an outgoing and return sonic signal, along with the distance between sonic transducers. Trigonometric relationships are used to calculate the wind speed in an orthogonal x-y-z coordinate system.

The time of flight measurement is also related to the speed of sound in air, which is a function of the air density (temperature and humidity). Through these relationships, the CSAT3B is able to output a measurement of sonic air temperature from which actual air temperature may be calculated if humidity is known.

For more complete details on the theory of operation of the CSAT3B, refer to Appendix B, *CSAT3B Measurement Theory*.

8.1.1 Algorithm Version 5

Since the release of the original CSAT3 in 1996, various improvements have been made to the algorithms used for signal processing and measurement output. Each time a significant change has been made to these algorithms, a new version number has been issued. The CSAT3B uses algorithm Version 5. Version 5 maintains many of the advantages of signal recognition and diagnostic sensitivity that were made possible by Version 3, while also adding the advantages of performance during precipitation events made possible by Version 4. It also resolves Version 4 issues of speed-of-sound measurement errors in very high wind conditions as reported by Burns et al., 2012 (see Section 10.1, *References*).

8.1.2 Effects of Crosswind on the Speed of Sound

The speed of sound is found by combining the out and back time-of-flight measurements (see Equation B-5 in Appendix B, *CSAT3B Measurement Theory*). While the parallel component of the wind along the sonic axis does not affect the measured speed of sound, the perpendicular component does. An online calculator can account for the effects of the perpendicular component of wind using the measured components of wind and simple trigonometry, or manually by using the methods described by Schotanus et al., 1983 and Liu et al., 2001 (see Section 10.1, *References*). The CSAT3B corrects for the effects of crosswind on the speed of sound.

The equations derived by Schotanus et al., 1983, apply to sonic anemometers that make speed of sound measurements from a single pair of transducers. Liu et al. extends these equations to sonic anemometers that measure the speed of sound on all three axes and then averages the results to a single speed of sound as with the CSAT3B. Liu et al. assume that the geometry of each individual three-dimensional anemometer is ideal when they derive the factors given in Table 1 of their publication.

NOTE

Liu et al., 2001, recommend that CSAT3B sonic temperature variances and sonic sensible heat flux are corrected for the effects of cross wind. The CSAT3B, however, performs an online correction. Additional correction of CSAT3B data for cross-wind effects will cause errors in the measured fluxes.

8.2 Operating Modes

The CSAT3B has different operating modes that are selected based on the desired measurement trigger source, presence of a data filter, and type of data output. Specifically, the following four modes are available:

- Mode 1: Datalogger-triggered | No filter | Datalogger-prompted output
- Mode 2: Self-triggered | Filtered | Datalogger-prompted output
- Mode 3: Self-triggered | No filter | Unprompted output to PC
- Mode 4: Self-triggered | Filtered | Unprompted output to PC

The mode is selected using the *Device Configuration Utility* under the *Measurement Settings* tab (see Section 7.1, *Settings*, for details on viewing and selecting settings). TABLE 8-1 gives a summary of the CSAT3B operating modes. The following sections give more information on the measurement trigger, data filters, and data output as a guide to selecting the appropriate mode. Mode 1 is the default operating mode for the CSAT3B and is recommended when fluxes are the primary interest.

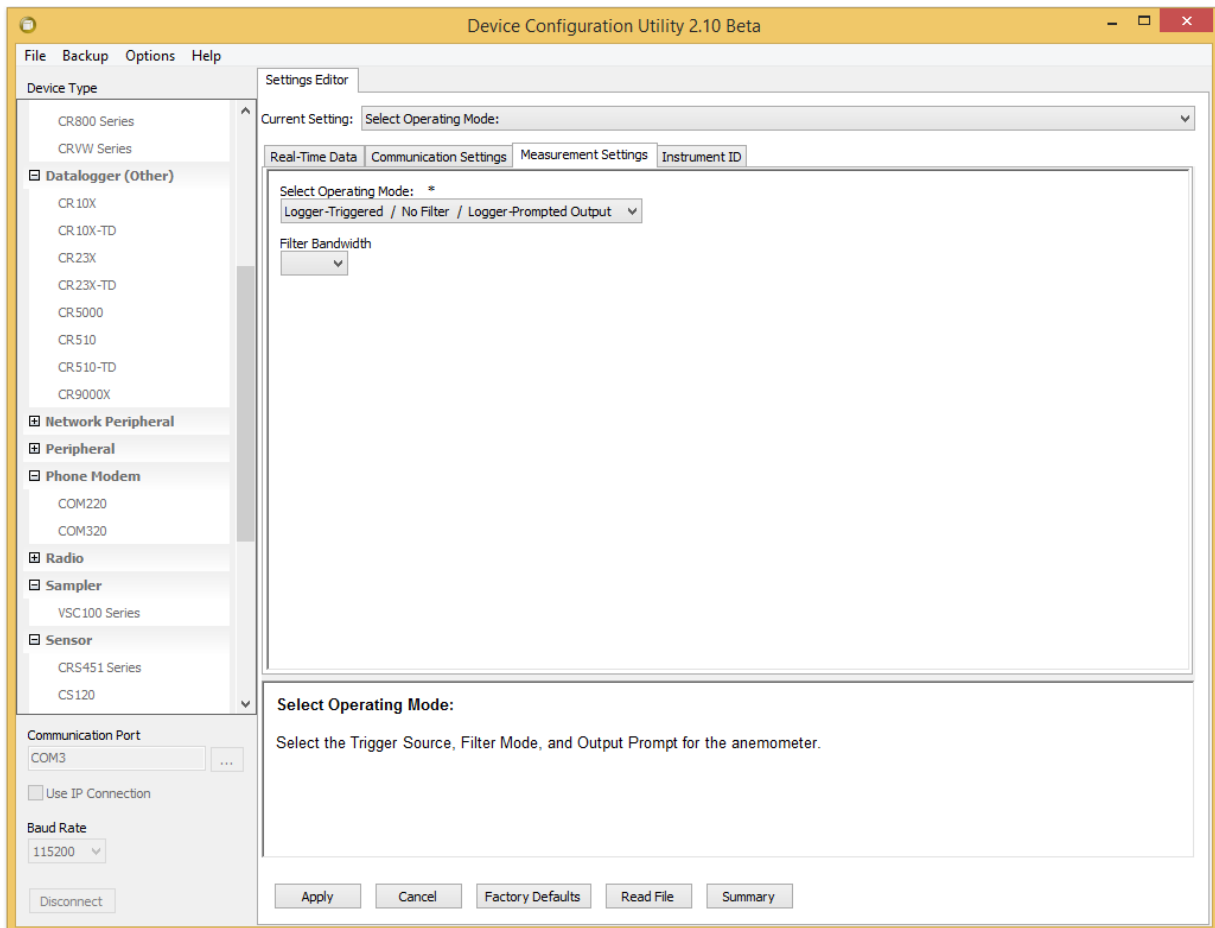

FIGURE 8-1. Measurement settings in Device Configuration Utility

TABLE 8-1. Overview of CSAT3B Operating Modes.

Mode	Measurement Trigger		Filters		Output Prompt	
	Source	Rate	Enabled	Bandwidth (Hz)	Source	Rate
1	Datalogger	1 to 100 Hz ¹	No	-	Datalogger	1 to 100 Hz*
2	CSAT3B	100 Hz	Yes	5, 10, 20, 25	Datalogger	1 to 100 Hz*
3	CSAT3B	100 Hz	No	-	CSAT3B	10, 20, 50, 100 Hz
4	CSAT3B	100 Hz	Yes	5, 10, 20, 25	CSAT3B	10, 20, 50, 100 Hz

¹ The exact rate is determined by the scan interval set in the CRBasic program of the datalogger.

NOTE The options for datalogger-prompted output require use of SDM or CPI communications, while the options for unprompted output to a PC require use of RS-485 or USB communications.

8.2.1 Measurement Trigger

A measurement trigger is the actual command to initiate a sonic measurement and can be driven by either a datalogger or the CSAT3B internal timer. If the trigger is given by a datalogger as in Mode 1, then no data filtering is done (bandwidth is wide open) since each trigger will initiate a single new measurement (single-measurement regime). The datalogger can trigger measurements at rates from 1 to 100 Hz. If the trigger is given by the internal CSAT3B timer as in Modes 2 - 4, the measurements will be self-triggered at a rate of 100 Hz. This results in an oversampled measurement regime where the 100 Hz samples may be optionally processed through a filter before being downsampled or decimated and output.

NOTE If a datalogger fails to provide a trigger and the CSAT3B has not been configured for unprompted output, the CSAT3B will enter into a lost-trigger state where it will output measurements at 1 Hz based on its internal timer. If the CSAT3B is in a lost-trigger state while connected with *Device Configuration Utility*, real-time anemometer data will flash on the screen at one second intervals. This is an indication that the settings should be checked. It does not indicate a problem with the CSAT3B hardware. Once a trigger is received by the CSAT3B, or once unprompted output is enabled, normal operation will ensue.

8.2.2 Data Filter

The optional data filter (Modes 2 and 4) takes the 100 Hz sample points that were self-triggered by the CSAT3B and runs them through a low-pass (high-cut) filter, resulting in a new filtered output at the same 100 Hz rate. The degree to which the data are filtered is determined by the user-selected filter bandwidth. This is selected from the *Device Configuration Utility* in the *Measurement Settings* tab.

The bandwidth is the frequency at which a signal is filtered to (1-1/e) of its original power. In cases where unaliased spectra from the CSAT3B are to be

analyzed, the user should choose a filter bandwidth that is at the Nyquist frequency, which is half the data output rate from the CSAT3B to the datalogger or PC. This will eliminate aliasing or the mismatch of signals to frequencies. The bandwidths that are available for selection are 5, 10, 20, and 25 Hz. If no filter is used as in Mode 3, the effective bandwidth will be 50 Hz, since the bandwidth is limited by the Nyquist frequency of the fundamental measurement rate of 100 Hz. Each bandwidth, including the effective 50 Hz bandwidth from unfiltered data, results in a different time delay between measurement and output. TABLE 8-2 summarizes the time delays for each filter. These time delays will need to be accounted for when aligning CSAT3B data with data from other fast-response sensors. Data alignment can be done automatically with a datalogger or during post-processing on a PC. TABLE 8-2 also shows the closest integer sample delays for various output rates.

If the primary interest of a study is fluxes rather than spectral analysis, there is no need to select a filter. With unfiltered data, the anemometer’s high frequency response is only limited by the geometry of the anemometer head, and in the case of self-triggered measurements, a 50 Hz effective bandwidth. This minimizes the possibility of underestimating high-frequency signal variations and covariations. This approach, however, aliases high-frequency information to lower frequencies. This aliasing is apparent in spectra from an upwards tail, when compared to the $-5/3$ power relationship (Kaimal and Finnigan), at frequencies approaching the Nyquist frequency of one-half the sample rate. This aliasing does not compromise the variances and covariances (and therefore, fluxes) computed from aliased data. The variance and covariance calculations are not frequency dependent, they simply measure a signal’s total variation or total covariation from two signals, respectively. Given this, under circumstances where measuring fluxes are the primary interest, it is recommended to operate without a filter and, if possible, have the datalogger provide the trigger.

TABLE 8-2. Time Delays by Mode and Filter

Mode	Delay between Measurement and Output		
1	1 Datalogger Scan Interval		
3	10 ms		
2 and 4	Bandwidth	5 Hz	795 ms
		10 Hz	395 ms
		20 Hz	195 ms
		25 Hz	155 ms

8.2.3 Data Output

After a measurement is triggered and optionally run through a filter, it is stored in the CSAT3B data buffer until it is output to either a datalogger or a PC.

Mode 1

In the case where a datalogger provides the measurement trigger (Mode 1), the trigger is issued each time the datalogger goes through a scan of the program and executes the **CSAT3B() CRBasic** instruction. See Section 8.4.1, *CRBasic*

Instructions, for details on the instruction. When the trigger is executed, it will also prompt the CSAT3B to output the most recent measurement in the buffer. This means that the data collected in the datalogger will be delayed by exactly one scan interval or timestamp.

NOTE

The earlier generation CSAT3 had a delay of two scan intervals.

The program code can correct for this delay before storing the data to a data table, or the raw time series data can be saved and aligned with other data during post-processing of the data. Once the one scan delay is accounted for, this method of triggering and prompting the CSAT3B with a datalogger is the best way to achieve optimum synchronicity with other fast-response sensors. Because the measurement was triggered according to the datalogger's clock, the timing is known exactly. If the datalogger makes measurements of other fast-response sensors via analog measurement, SDM, or CPI, then the measurements from the CSAT3B and other sensors can be synchronized precisely.

Mode 2

In the case where the CSAT3B is self-triggered and filtered, the output data can still be collected by a datalogger (Mode 2). In this case, the datalogger will prompt the CSAT3B for an output each time it executes the **CSAT3B() CRBasic** instruction in the program scan. When the datalogger prompt is received by the CSAT3B, it will output the most recent 100 Hz filtered sample in its buffer to the datalogger. This filtered data is delayed by a certain time interval (given in TABLE 8-2) and should be taken into account when aligning with other fast-response sensors. There are additional synchronicity considerations. Because the measurement was not triggered by the datalogger according to its own clock, the sample received by the datalogger may have a small synchronicity error between -5 and +5 milliseconds with respect to the datalogger's timestamp. The actual error depends on the operational mode and the output rate, as shown in TABLE 8-3.

Modes 3 and 4

If the CSAT3B measurements are to be self-triggered and output to a PC, as in Modes 3 and 4, an unprompted output operating mode should be selected. Available output rates for the CSAT3B are 10, 20, 50, or 100 Hz. In unprompted mode, the CSAT3B will downsample or decimate the 100 Hz buffer data (unfiltered or filtered, depending on whether the user has selected Mode 3 or Mode 4, respectively) to output at the appropriate rate. The unprompted output record is an ASCII string of comma-delimited data terminated by a carriage return and contains the following seven data fields:

- 1) u_x – x-axis wind speed in meters per second ($m \cdot s^{-1}$)
- 2) u_y – y-axis wind speed in meters per second ($m \cdot s^{-1}$)
- 3) u_z – z-axis wind speed in meters per second ($m \cdot s^{-1}$)
- 4) T_s – Sonic temperature in degrees Celsius ($^{\circ}C$)
- 5) Diagnostic word
- 6) Record counter
- 7) Signature

The record counter is a decimal value that is incremented each record until reaching a maximum value of 63, at which point it starts back over at zero. The counter may be used to ensure each record is not a duplicate of the last and that a record has not been omitted.

The final data field in each record is the signature, a four character hexadecimal value that is a function of the specific sequence and number of bytes in the output array. The PC may calculate its own signature using each transmitted byte until reaching the signature data field. The computed signature and the transmitted signature are compared. If they match, the data were received correctly. This is very similar to a Cyclic-Redundancy-Check (CRC).

NOTE

Signature checking is done automatically by a datalogger when using SMD or CPI communications and does not require extra programming by the user.

In most situations, a PC computes the signature by reading in the ASCII data and extracting the last four ASCII characters, casting them as Long data type. The signature is then calculated on the data sent from the CSAT3B, starting with u_x and ending with the counter. All the characters after the counter are not part of the signature. Once the signature is computed using the algorithm below, it is compared to the transmitted signature. If signatures do not match, the data should be disregarded.

The following block of code is an example implementation of Campbell Scientific's signature algorithm in the programming language C. To generate the signature of an output array of bytes, the "seed" needs to be initialized to 0xaaaa and a pointer passed to the first byte of the output array. The number of bytes in the output array should be entered in as the "swath". The returned value is the computed signature.

```
// signature(), signature algorithm.
// Standard signature is initialized with a seed of 0xaaaa.
// Returns signature.
unsigned short signature( unsigned char* buf, int swath, unsigned short seed ) {
    unsigned char msb, lsb;
    unsigned char b;
    int i;
    msb = seed >> 8;
    lsb = seed;
    for( i = 0; i < swath; i++ ) {
        b = (lsb << 1) + msb + *buf++;
        if( lsb & 0x80 ) b++;
        msb = lsb;
        lsb = b;
    }
    return (unsigned short)((msb << 8) + lsb);
}
```

FIGURE 8-2 shows an example of unprompted output (RS-485 or USB) to a PC. A timestamp for the incoming data record may be assigned by the PC, where the interval between records is 1/unprompted output rate. The data in each unprompted output record will be delayed according to the filter selected (see TABLE 8-2). Even after accounting for the sample delay, there may be a synchronicity error between the PC and the CSAT3B since they each have their own clocks. TABLE 8-3 below shows the possible synchronicity errors for each output rate.

```

|
0.08945,0.06552,0.05726,19.69336,0,5,c3a6
0.10103,0.06517,0.05312,19.70499,0,6,3927
0.09045,0.04732,0.04198,19.71161,0,7,d7e5
0.08199,0.03341,0.03421,19.73416,0,8,4ad9
0.08867,0.03522,0.03378,19.75360,0,9,e314
0.08675,0.02142,0.03289,19.76858,0,10,9b60
0.09035,0.01987,0.03667,19.78433,0,11,931a
0.09960,0.02615,0.04330,19.79236,0,12,14a1
0.09489,0.02513,0.05120,19.79083,0,13,0c0d
0.09513,0.02403,0.05648,19.79037,0,14,c30d
0.10715,0.02723,0.05739,19.78729,0,15,a14c
0.11630,0.03674,0.05579,19.78812,0,16,5cd7
    
```

FIGURE 8-2. Example of unprompted RS-485 or USB output to PC

TABLE 8-3. CSAT3B Synchronicity Errors

Mode	Synchronicity Error		
1	0 ms		
2	-5 to +5 ms		
3 and 4	Output Rate	10 Hz	0 to 100 ms
		20 Hz	0 to 50 ms
		50 Hz	0 to 20 ms
		100 Hz	0 to 10 ms

8.2.4 Operating Mode Recommendations

Due to the advantages in making synchronous measurements, Campbell Scientific recommends using a datalogger that supports SDM or CPI communications to collect data from the CSAT3B. If flux measurements are the primary interest, Campbell Scientific further recommends that the CSAT3B be operated in Mode 1 where the datalogger triggers the measurements, no filters are applied, and the data are collected by the datalogger. If unaliased spectra are desired for characterization of the system and site, Mode 2 is recommended in which the measurements are self-triggered, a filter is applied with a bandwidth that is half the datalogger scan rate, and the data are collected with the datalogger.

8.3 Synchronization with other sensors

As there is a delay between the CSAT3B’s measurement and output to a datalogger or PC (see TABLE 8-2), the CSAT3B data will be slightly older than the record’s timestamp (recall that the timestamp is assigned to the record by the datalogger or PC). This delay is not important when calculating covariances between variables from the CSAT3B since the variables are already synchronized and aligned with one another. However, when covariances are being calculated between CSAT3B data and data from other fast-response sensors, the time difference must be accounted for. As an example, suppose a datalogger is making 10 Hz (100 ms) measurements of a CSAT3B and an analog sensor such as a fine-wire thermocouple. In the raw data table of the datalogger, the timestamp for the thermocouple data will be

when the measurement actually took place, whereas the CSAT3B data will be delayed by 100 ms. Before covariances are calculated, the fine-wire thermocouple data should be lagged by one scan interval (100 ms) so that all data are aligned in time. This lagging of the data can be done online with the datalogger, or it is often done offline using PC software.

TABLE 8-4 shows the measurement lags that should be applied to analog measurements or measurements with no delay in order to align them with CSAT3B data. The lags shown for Modes 2 and 4, indicate the number of output scans that the analog measurements should be delayed.

For example, in Mode 2 where data is being filtered and then output is prompted by a datalogger, if the datalogger has a 10 Hz scan rate and the CSAT3B has been set to use a 5 Hz bandwidth filter, the analog measurements should be delayed by 8 datalogger scans (8 · 100ms/scan = 800 ms). TABLE 8-4 also indicates the preferred settings for flux measurements and spectral analysis. As discussed previously, for spectral analysis, the bandwidth should be selected as half the output rate. For flux applications, the output rate or sampling frequency need not be greater than 10 or 20 Hz in order to reduce unwieldy data sets, and the bandwidth may be left fairly wide open (for example, 20 Hz) to ensure high frequency fluxes are retained in the signal.

TABLE 8-4. Measurement Lags for Analog Measurements or Measurements with No Delay						
Mode	Measurement Lag (in output samples), N_{delay}					
1 ¹	1 datalogger scan					
3	Unprompted output rate/100 (lag in seconds)					
2 and 4		Output rate (f_{scan})				
		10 Hz	20 Hz	50 Hz	100 Hz	
	Bandwidth (BW)	5 Hz	8 ³	16	40	80
		10 Hz	4	8 ³	20	40
		20 Hz	2 ²	4 ²	10	20
25 Hz		-	-	8 ³	16	

¹ Best for flux applications

² Good for flux applications

³ Recommended for spectral analysis

$$N_{delay} = \frac{f_{scan}}{BW} \times 4$$

8.4 Datalogger Programming using SDM or CPI

The CSAT3B() CRBasic instructions control and retrieve data from the CSAT3B. These instructions are available on the CR6, CR800/850, CR1000, and CR3000 dataloggers.

The following sections give specifics about CRBasic instructions. Examples of common CRBasic programs for the CSAT3B are shown in Appendix C, *Example CRBasic Datalogger Programs*.

8.4.1 CRBasic Instructions

8.4.1.1 CSAT3B()

The **CSAT3B()** instruction is the primary instruction used to retrieve anemometer data from the CSAT3B. This will set the operating mode of the anemometer and retrieve the wind, sonic temperature, and diagnostic information. The instruction requires four parameters which are further described in the following sections:

- 1) Destination
- 2) Bus
- 3) Address
- 4) OperatingMode

The **CSAT3B()** instruction should appear in the main scan of the CRBasic program operating in pipeline mode.

Destination:

This variable will store the values returned by the anemometer. The destination variable must be declared as a float (default) with at least five elements. The CSAT3B returns the following data in response to a measurement trigger:

- 1) u_x – x-axis wind speed in meters per second ($\text{m}\cdot\text{s}^{-1}$)
- 2) u_y – y-axis wind speed in meters per second ($\text{m}\cdot\text{s}^{-1}$)
- 3) u_z – z-axis wind speed in meters per second ($\text{m}\cdot\text{s}^{-1}$)
- 4) T_s – Sonic Temperature in degrees Celsius ($^{\circ}\text{C}$)
- 5) Diagnostic word

Bus:

This parameter determines whether the communications to the CSAT3B are done via the SDM or CPI bus. A '0' indicates SDM and a '1' indicates CPI. This parameter must be a constant.

Address:

This parameter identifies the unique address of the CSAT3B on the communication bus. For SDM, this number may be in the range of 1 to 14. For CPI, this number may be in the range 1 to 120. This parameter must be a constant.

OperatingMode:

This parameter controls the trigger source and the application of filters to the anemometer data. This parameter must be a constant.

8.4.1.2 CSAT3BMonitor()

The **CSAT3BMonitor()** instruction provides auxiliary information pertaining to the physical condition of the anemometer. This retrieves the internal temperature and relative humidity of the electronics enclosure, and also the inclination of the anemometer. The instruction requires three parameters: *Destination*; *Bus*; and *Address*. The **CSAT3BMonitor()** instruction should appear in a slow sequence of the CRBasic program operating in pipeline mode.

Destination:

This variable will store the values returned by the anemometer. The destination variable must be declared as a float (default) with at least four elements. The CSAT3B returns the following data in response to this instruction:

- 1) Electronics temperature in degrees Celsius (°C)
- 2) Electronics relative humidity as a percent (%)
- 3) Inclinometer pitch in degrees (°)
- 4) Inclinometer roll in degrees (°)

Bus:

This parameter determines whether the communications to the CSAT3B are done via the SDM or CPI bus. A '0' indicates SDM and a '1' indicates CPI. This parameter must be a constant.

Address:

This parameter identifies the unique address of the CSAT3B on the communication bus. For SDM, this number may be in the range 1 to 14. For CPI, this number may be in the range 1 to 120. This parameter must be a constant.

8.4.2 Diagnostic Word

The fifth output from the CSAT3B is the diagnostic word. The diagnostic word describes the status of the anemometer and is useful in filtering data. For example, when the anemometer is locking in on the ultrasonic signals after receiving the acquire signals command, the NaN it sends to the datalogger for the science data can be filtered out of the statistics based on the diagnostic word. See the example program in Appendix C, *Example CRBasic Datalogger Program*.

The diagnostic word is formatted as a simple 32-bit binary word. Each bit in the diagnostic word represents a different warning flag related to the operation of the CSAT3B. The datalogger will display the diagnostic word as a base-10 integer. Viewed in this manner, each of the 32 bits has a different magnitude as a decimal number. The resultant decimal number will be the sum of the decimal magnitudes of each of the bits that are set. TABLE 8-5 summarizes the CSAT3B's diagnostic word flags.

Bit #	Hex Value	Decimal Value	Flag Name	Description	Troubleshooting
0	0x0001	1	Low Amplitude	Ultrasonic signal is too small	There may be an obstruction in the anemometer path or on the transducer face
1	0x0002	2	High Amplitude	Ultrasonic signal is too large	An obstruction, in the anemometer path or on the transducer face, was removed
2	0x0004	4	Tracking	The signal lock is poor	There may be an obstruction in the anemometer path or on the transducer face

TABLE 8-5. Diagnostic Word Flags

Bit #	Hex Value	Decimal Value	Flag Name	Description	Troubleshooting
3	0x0008	8	High Delta C	Difference in the speed of sound between the three non-orthogonal axes is greater than 2.360 m·s ⁻¹ (~4 °C @ 25 °C)	The anemometer path length may have been altered or the anemometer head is structurally damaged
4	0x0010	16	Acquiring	Indicates that the anemometer is trying to acquire the sonic signal	There may be an obstruction in the anemometer path or on the transducer face or a transducer has failed
5	0x0020	32	Low Voltage	The supply voltage to the anemometer is below 9.0 Vdc	Check the power supply
6	0x0040	64	Trigger Error	A measurement trigger has not been received for at least 1 sec, or the time interval between triggers is varying by greater than 5%	Check wiring to the datalogger, and check the datalogger program for the expected trigger rate
7	0x0080	128	Internal Humidity Warning	The relative humidity inside the CSAT3B block is greater than 80%	Change the internal desiccant canister (see Section 9.3, <i>Desiccant</i>)
8	0x0100	256	Memory Error	There is a signature mismatch from the calibration file or another section of memory	Resend an OS and/or cal file to the CSAT3B; contact Campbell Scientific for details

8.4.3 SDMTrigger()

The **SDMTrigger()** is an SDM Input/Output instruction that controls SDM devices that support the group trigger protocol, including the CSAT3B. Up to 15 group-trigger devices can be connected to the SDM bus. All group-trigger devices are triggered for simultaneous measurements with the SDMTrigger. The data from each device is retrieved with the appropriate device-specific instruction.

The **SDMTrigger()** instruction is unnecessary when using CPI communications because group triggering is integrated and enabled into the CPI protocol. Multiple CPI devices will inherently be synchronized.

9. Maintenance and Troubleshooting

9.1 General Maintenance

With no moving parts, maintenance of the CSAT3B is minimal and limited to the following:

- Replacing rain wicks
- Replacing the desiccant canister
- Monitoring diagnostics and measurement offsets to determine when factory recalibration is needed

The sections below address these maintenance activities.

CAUTION

The cover plate to the electronics should only be removed by qualified technicians at the factory. When covered, the electronics are well protected against transient voltages during handling and operation. Once uncovered, however, they are highly sensitive to electrostatic discharge. There are no user-serviceable components beneath the cover plate. Opening this will void the warranty on the anemometer.

9.2 Sonic Wicks

Like other ultrasonic anemometers, the CSAT3B is unable to measure wind when water droplets completely obscure the face of the transducers. CSAT3B algorithm Version 5 along with sonic wicks (shown in FIGURE 9-1), improve the performance of the CSAT3B in rainy conditions. Under certain conditions, the wicking properties of the sonic wicks may not be adequate. In these circumstances, the CSAT3B may report diagnostic error conditions or erroneous data until the water droplets evaporate or are manually removed. Droplets can be removed by dabbing a cotton swab or tissue on the face of the transducer.

If site conditions are such that the wicks are unnecessary, gently remove the wicks from the transducers, taking care not to damage or peel the matching layer (rubber tips) from the brass housing of the transducers. Remove the wicks during the winter, as the wicks will accumulate snow or freezing rain to the point where the transducer face will be obscured.

CAUTION

Lightly dab the face of the transducers to remove water droplets. Applying excessive force on the face of the transducer may damage the matching layer. Do not attempt to remove ice or frost without melting it first by gently warming the anemometer.

If the wicks are to be permanently installed at the site, ensure that the wicks are located in the proper position. FIGURE 9-1 shows the proper orientation of the transducer wicks. The top wick must be flush with the transducer face, with the wick tail located at the lowest point of the transducer (FIGURE 9-1, left). The end of the bottom transducer wick must extend above the transducer

face by between one half and one mesh lines (FIGURE 9-1, right). Secure the wicks to the transducer with a drop of adhesive, such as super glue.

Replacement top wicks (pn 17388) and bottom wicks (pn 17389) can be purchased from Campbell Scientific. A complete set of wicks for one CSAT3B consists of three top wicks and three bottom wicks.

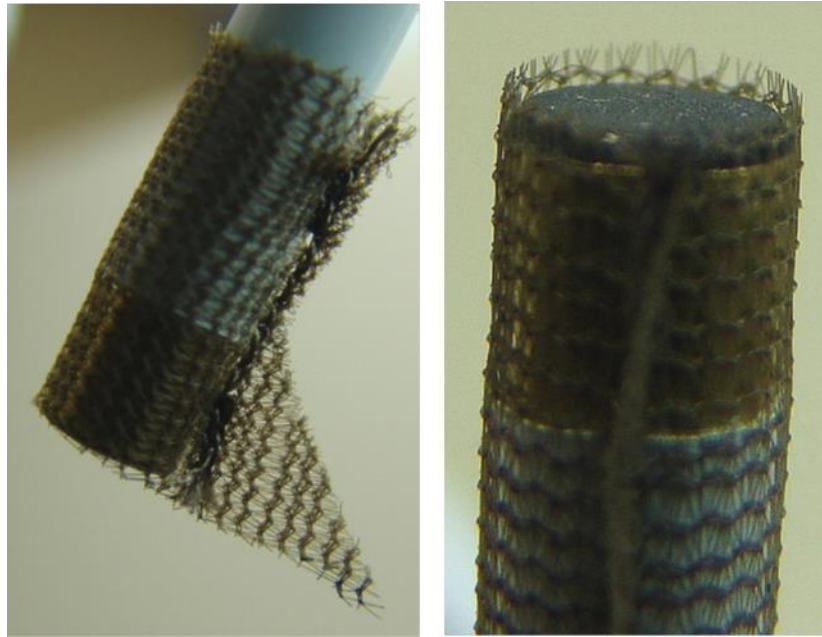

FIGURE 9-1. Proper orientation of sonic top wick (left) and bottom wick (right)

9.3 Desiccant

To prevent liquid water from coming in contact with the CSAT3B electronics, the internal humidity must be maintained at non-condensing levels. The CSAT3B has an on-board relative humidity sensor that continuously monitors the humidity inside the enclosure. This humidity ranges between 0 and 100%. As temperature decreases, the capacity of air to hold water also decreases and the relative humidity will increase even if no additional water has been introduced into the closed system. As the relative humidity approaches 100%, condensation will begin to form on the internal surfaces.

The CSAT3B has a cavity to hold a replaceable desiccant canister that removes water from the air (see FIGURE 9-2). Water molecules will unavoidably ingress into the electronics over time, so the internal humidity of the CSAT3B head should periodically be checked. This can be done automatically with a datalogger if the datalogger program uses the **CSAT3BMonitor()** instruction in *CRBasic*, or manually by connecting a CSAT3B to a PC using the USB cable and then launching the *Device Configuration Utility*. Under the *Settings Editor* tab of the utility, there is secondary tab for *Real-Time Data*, where the internal humidity measurement will be displayed along with various other measurements.

If monitoring shows the internal humidity of the CSAT3B rising above 50%, including during night time cooling cycles, the desiccant should be replaced with canisters that can be purchased from Campbell Scientific as pn 30749. The desiccant is held in the small canister that is installed on the underside of the anemometer block inside of the brass screw cap (see FIGURE 9-2). Use a large flat-headed screwdriver to unscrew the cap and remove the canister. Replace the old canister with an unused one.

The new canister should appear blue in color. A pink-hued canister indicates that moisture has been absorbed, and the canister should be discarded and replaced with a new one. When replacing the brass screw cap, ensure the cap is tightened until the head of the screw is flush with the housing and the o-ring cannot be seen.



FIGURE 9-2. Exploded view of CSAT3B desiccant canister

9.4 Calibration

The CSAT3B is calibrated at the factory over the temperature range of -30 to 50 °C, as sonic transducer response is a function of temperature. Any measurements taken at temperatures outside of this range will be suspect.

The CSAT3B does not require field calibration; however, it may require a factory recalibration every few years. An indication that the CSAT3B is due to be returned to the factory for recalibration is when diagnostic flags are persistent under dry conditions with little to no wind and with no obstruction in the ultrasonic paths. A wind offset greater than the specifications found in

Section 6, *Specifications*, is another indication that a recalibration is due. To check for wind offset, refer to Section 9.4.1, *Test for Wind Offset*.

9.4.1 Test for Wind Offset

Testing wind offset on a CSAT3B requires creating an environment where there is no wind. Because it is difficult to do this in the field, wind offset data from the CSAT3B should be collected in a field office or the lab. A zero-wind environment can be created with a kitchen waste bin liner. The following steps should be taken to test the CSAT3B for wind offset.

1. Mount the head using the horizontal mount boom (as described in Section 4.1, *Hardware Connections*, or hang the head from the block that supports the CSAT3B upper and lower arms. Do not lay the CSAT3B head on its side or balance it on the transducers, as this will affect its measurements.
2. Cover the CSAT3B head with a medium (13-gallon) kitchen waste bin liner. Close the opening of the liner by folding, taping, or tying, to prevent air from moving in and out of the liner. Temporarily disable the HVAC system in the room, or cover air vents that may cause air drafts to pass by the CSAT3B. Ensure that the liner does not obstruct any of the three CSAT3B sonic paths.
3. Connect the CSAT3B power and communications cable to the datalogger referring to Section 4.2, *Communications Connections*. Connect to the datalogger with *PC200W*, *PC400*, or *LoggerNet*.
4. Use the real time monitoring graph display to create two graphs.
 - a. On the first graph add the u_x and u_y wind components and set the y limits from -0.08 to 0.08 as shown in FIGURE 9-3.
 - b. On the second graph add the u_z wind component and set the y limits from -0.04 to 0.04 as shown in FIGURE 9-4.
 - c. For both graphs, set **Graph Width** to 1 minute and **Update Interval** to 1 second.

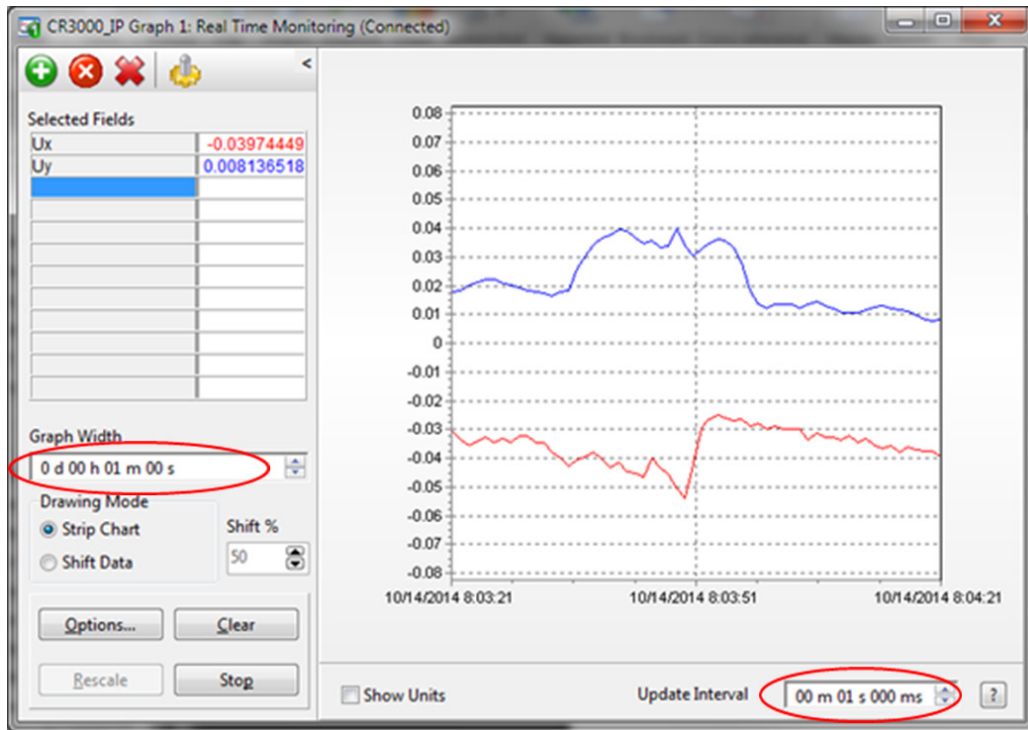

FIGURE 9-3. CSAT3B real-time data with 1 sec update and u_x and u_y wind component graphed

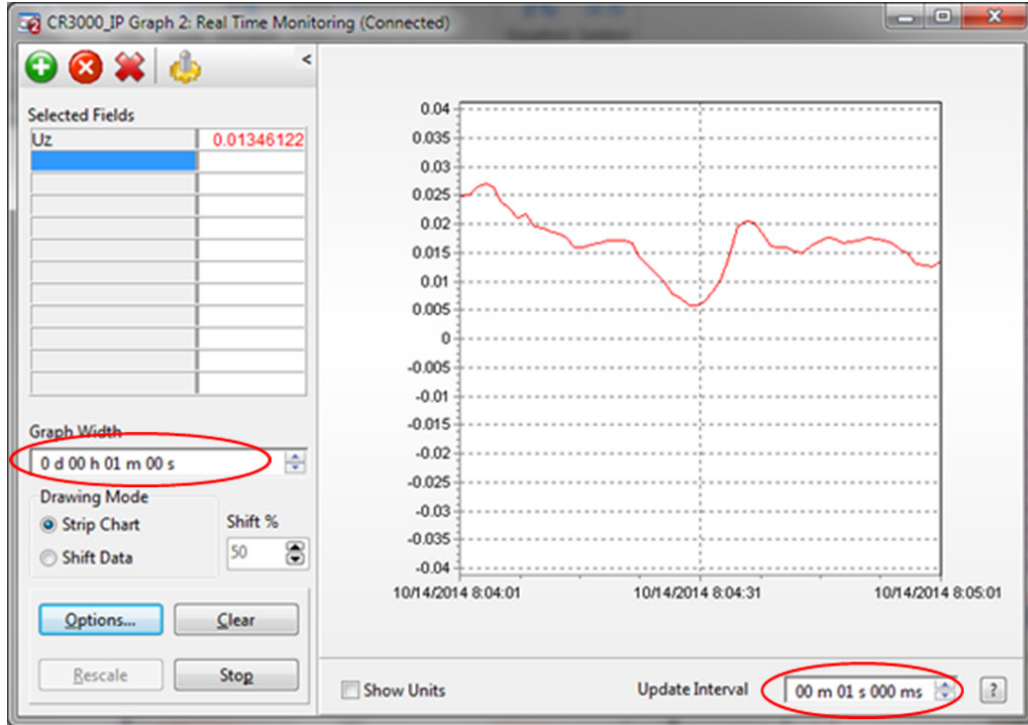

FIGURE 9-4. CSAT3B real-time data with 1 sec update and u_z wind component graphed

Graph 1 minute of wind data from the CSAT3B while it is in the zero wind environment. The wind offset should be less than $\pm 8 \text{ cm}\cdot\text{s}^{-1}$ ($0.08 \text{ m}\cdot\text{s}^{-1}$) for u_x and u_y , and less than $\pm 4 \text{ cm}\cdot\text{s}^{-1}$ ($0.04 \text{ m}\cdot\text{s}^{-1}$) for u_z . If the CSAT3B wind offset is greater than these specifications, contact Campbell Scientific for an RMA number to recalibrate the CSAT3B.

NOTE

When returning a CSAT3B for factory recalibration or repair, it is important to ship the unit with the foam inserts (see Section 5.2.2.1, *Sonic Carrying Case*) provided from the factory).

9.5 Troubleshooting

Most problems that occur with the CSAT3B will generate a flag in the Diagnostic Word that are set high (see Section 8.4.2, *Diagnostic Word*, and TABLE 8-5). It is normal to see occasional sonic flags being set due to precipitation, insects, spider webs, birds, etc. that pass through one or more of the sonic paths and obstruct the signal. If diagnostic flags are persistently high, however, this could indicate a more serious problem. In the case that diagnostic flags are persistent, troubleshoot with the following steps:

1. Perform a visual inspection of the CSAT3B. Make sure it is clear from anything that might obstruct the sonic signal. Check for signs that the geometry of the arms has changed in any way, possibly from an impact from another object.
2. Check all wiring connections between the CSAT3B and datalogger.
3. Check to see if the diagnostic flags are still high.
4. If diagnostic flags persist, remove the CSAT3B from the site and perform a zero-wind offset as described in Section 9.4.1, *Test for Wind Offset*. Check to see if the diagnostic flags are any different once inside the laboratory.
5. In case the diagnostic flags are related to a bug or corruption of the OS, send a new OS following the instructions in Section 9.5.1, *Sending an OS to the CSAT3B*.
6. If the problems are still unresolved, contact an application engineer at Campbell Scientific. If possible, be prepared to send a file of CSAT3B output data, including the diagnostic word, to the application engineer. If it is determined that the unit must be returned to the factory for recalibration and/or repair an RMA will be required (see Section 9.6, *Returning the CSAT3B*).

9.5.1 Sending an OS to the CSAT3B

To send an operating system (OS) to the CSAT3B, follow these steps:

1. Select the *Support* tab of the CSAT3B web page (www.campbellsci.com/cs3b) to download the latest version of the CSAT3B OS to your PC.
2. Connect to the CSAT3B and launch the *Device Configuration Utility* as described in Section 7.1, *Settings*.

- After connecting to the CSAT3B, click on the *Send OS* tab at the top of the *Device Configuration Utility* main screen. Click on the **Start** button at the bottom of the page, select the .obj file that you downloaded from the Campbell website, and click **Open**. The OS will then be sent, followed by a confirmation message that it was loaded properly.

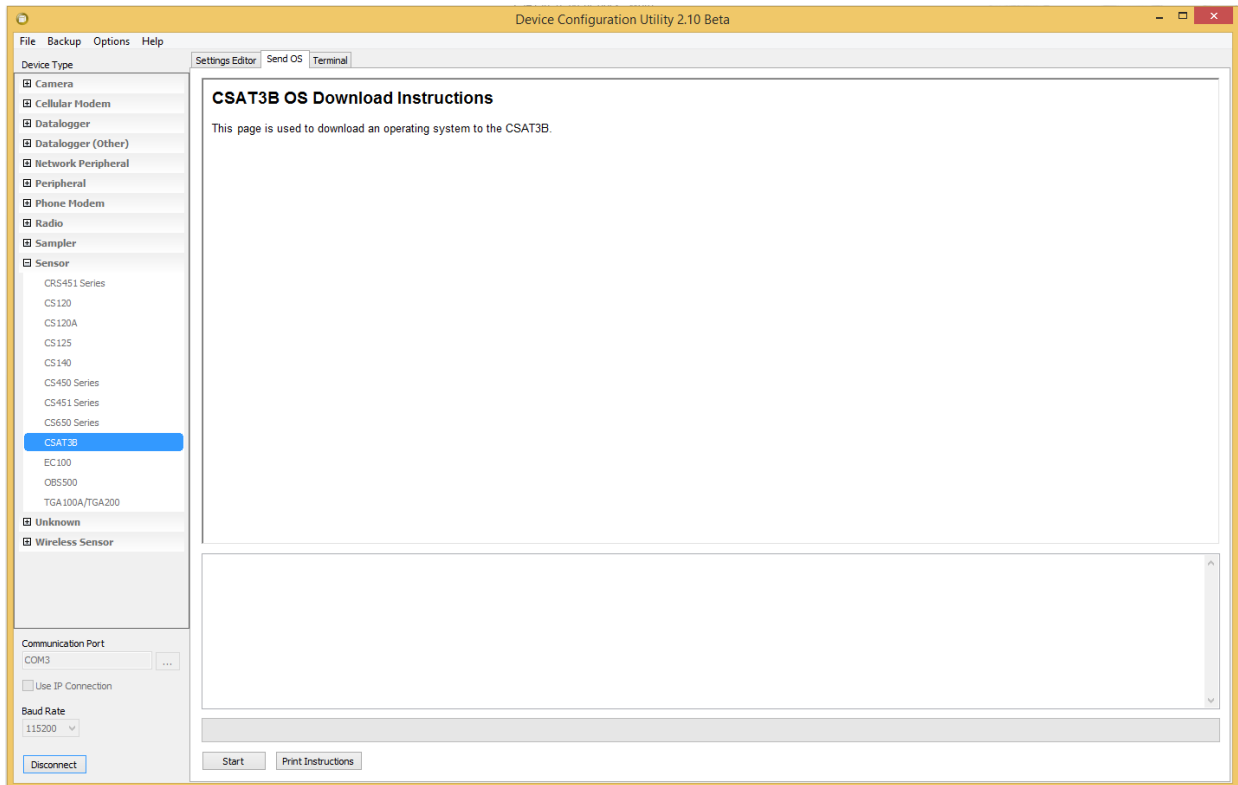

FIGURE 9-5. The Send OS screen in the Device Configuration Utility

9.6 Returning the CSAT3B

If there is need to return the CSAT3B either for calibration or repair, please follow the detailed instructions provided in the [Assistance](#) section at the beginning of this manual which gives instructions for generating an RMA number. If additional help is needed, please contact an application engineer at Campbell Scientific. When preparing the CSAT3B for shipment, be sure to package it in the same foam that it was sent in. If the foam cannot be found, new foam should be ordered from Campbell Scientific before returning the unit.

10. Reference and Attributions

10.1 References

Liu, H., Peters, G. and Foken, T.: 2001, "New Equations for Sonic Temperature Variance and Buoyancy Heat Flux with an Omnidirectional Sonic Anemometer", *Boundary-Layer Meteorol.*, **100**, 459-468.

Schotanus, P., Nieuwstadt, F. T. M. and de Bruin, H. A. R.: 1983, "Temperature Measurement with a Sonic Anemometer and its Application to Heat and Moisture Fluxes", *Boundary-Layer Meteorol.*, **26**, 81-93.

Burns, S. P., Horst, T. W., Jacobsen, L., Blanken P. D. and Monson, R. K.: 2012, "Using sonic anemometer temperature to measure sensible heat flux in strong winds", *Atmos. Meas. Tech.*, **5**, 2095-2111.

Kaimal, J. C. and Finnigan J. J.: 1994, "Atmospheric Boundary Layer Flows", *Oxford University Press*.

Appendix A. CSAT3B Orientation

A.1 Determining True North and Sensor Orientation

The orientation of the CSAT3B negative x-axis is found by reading a magnetic compass and applying the site-specific correction for magnetic declination; where the magnetic declination is the number of degrees between True North and Magnetic North. Magnetic declination for a specific site can be obtained from a USGS map, local airport, or through a NOAA web calculator (Appendix A.2, *Online Magnetic Declination Calculator*). A general map in FIGURE A-1 taken from

www.ngdc.noaa.gov/geomag/img/DeclinationMap_US.png shows magnetic declination for the conterminous United States in 2010.

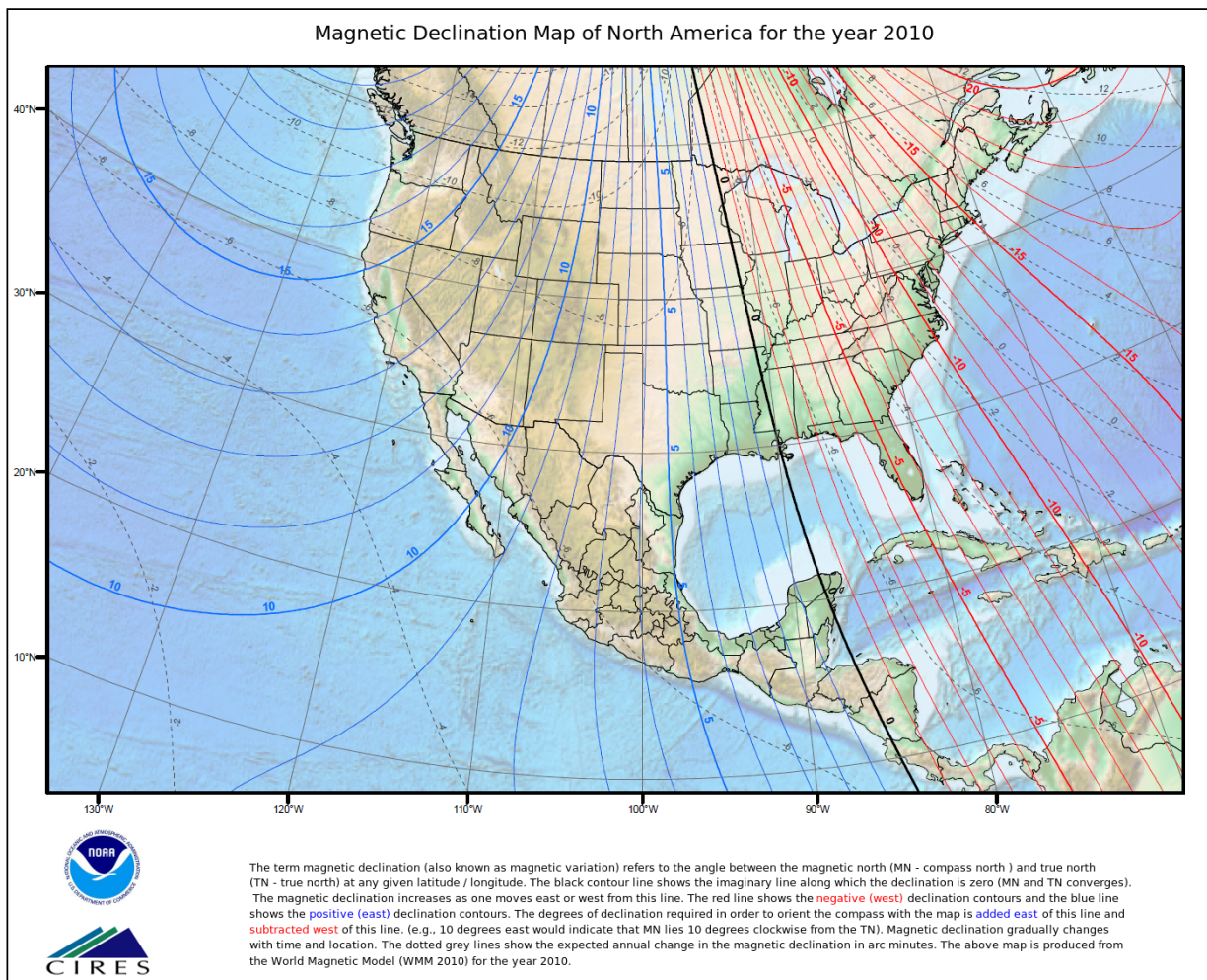

FIGURE A-1. Magnetic declination for the conterminous United States (2010)

Declination angles are always subtracted from the compass reading to find True North. A declination angle East of True North is reported as positive a value and is subtracted from 360 (0) degrees to find True North as shown FIGURE A-2. A declination angle West of True North is reported as a negative value and is also subtracted from 0 (360) degrees to find True North as shown in FIGURE A-3. Note that when a negative number is subtracted from a positive number, the resulting arithmetic operation is addition.

For example, the declination for Longmont, CO (10 June 2006) is 9.67° (the angle is East of True North, so it is reported as positive), thus True North is $360^\circ - 9.67^\circ$, or 350.33° as read on a compass. Likewise, the declination for Mc Henry, IL (10 June 2006) is -2.68° , and True North is $0^\circ - (-2.68^\circ)$, or 2.68° as read on a compass.

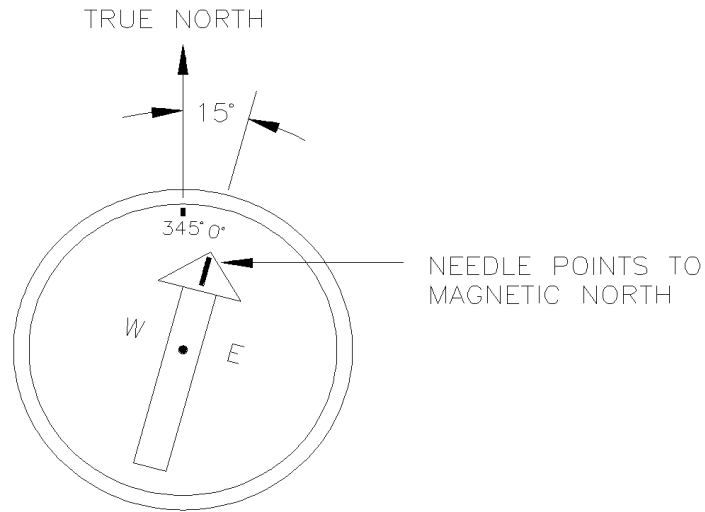

FIGURE A-2. A declination angle east of true north (positive) is subtracted from 360 (0) degrees to find true north

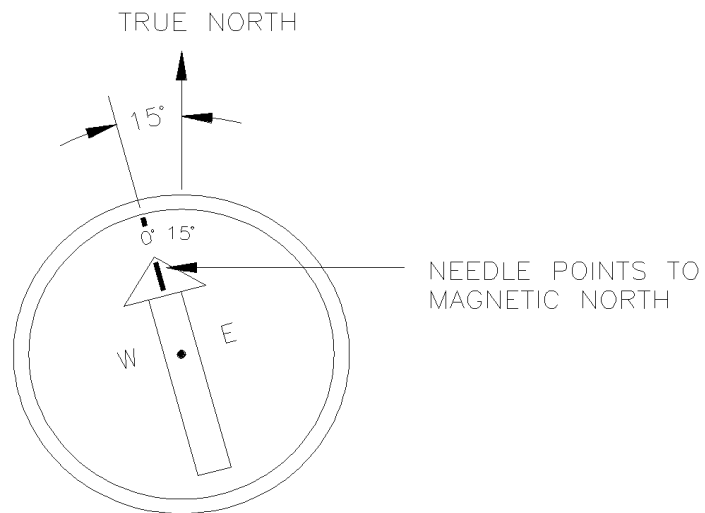

FIGURE A-3. A declination angle west of true north (negative) is subtracted from 0 (360) degrees to find true north

A.2 Online Magnetic Declination Calculator

The magnetic declination calculator web calculator published by NOAA's Geophysical Data Center is available at the following URL: www.ngdc.noaa.gov/geomag-web/#declination. After the web page loads, enter the zip code, country and city, or latitude and longitude of the site, then click on **Calculate** to get the declination for that site (FIGURE A-4).

NOAA NATIONAL GEOPHYSICAL DATA CENTER
NATIONAL OCEANIC AND ATMOSPHERIC ADMINISTRATION

NOAA > NESDIS > NGDC > Geomagnetism

Magnetic Field Calculators

Declination US Historic Declination Magnetic Field Magnetic Field Component Grid

[Instructions](#)

Estimated Value of Magnetic Declination

Declination is calculated using the current World Magnetic Model (WMM) or the International Geomagnetic Reference Field (IGRF) model. Declination results are typically accurate to 30 minutes of arc, but users should be aware that several environmental factors can cause disturbances in the magnetic field.

Calculate Declination

Location

* Latitude: S N

* Longitude: W E

Model

* Model: IGRF 11 WMM 2010

Date

* Date: Year Month Day

Result

* Result format: HTML XML CSV PDF

Lookup location

If you are unsure about your city's latitude and longitude, try entering your zip code or selecting your state below, or visit the [U.S. Gazetteer](#). Outside the USA try the [Getty Thesaurus](#).

Location (longitude 180W to 180E, latitude 90S to 90N).

Zip Code:

- OR -

Country:

City:

FIGURE A-4. NOAA magnetic declination calculator

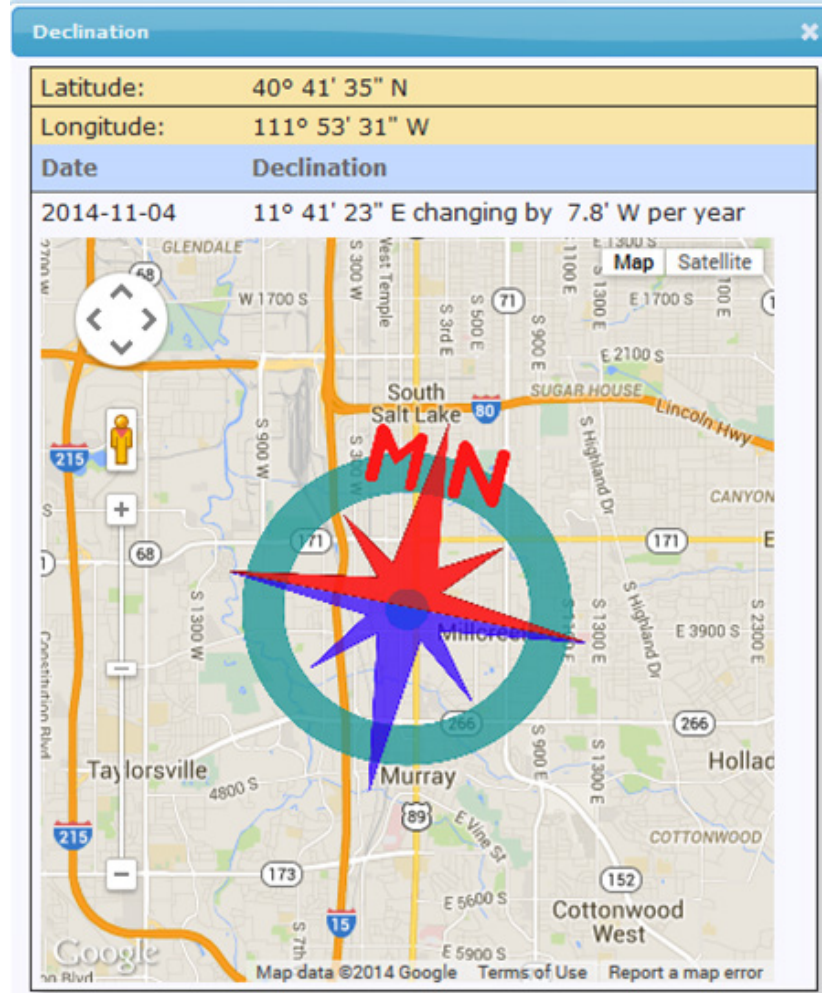

FIGURE A-5. NOAA magnetic calculator results

The declination for Salt Lake City, UT is 11.7° (4 November, 2014). As shown in FIGURE A-5, the declination for Utah is positive (east of north), so true north for this site is $360 - 11.7$, or 348.3° . The annual change is -7.8 minutes/year or 7.8 minutes west per year.

Appendix B. CSAT3B Measurement Theory

B.1 Theory of Operation

B.1.1 Wind Speed

Each axis of the CSAT3B pulses two ultrasonic signals in opposite directions. The time of flight of the first signal (out) is given by:

$$t_o = \frac{d}{c + u_a} \quad (B-1)$$

and the time of flight of the second signal (back) is given by:

$$t_b = \frac{d}{c - u_a} \quad (B-2)$$

where:

- t_o = time of flight out along the transducer axis
- t_b = time of flight back, in the opposite direction
- u_a = wind speed along the transducer axis
- d = distance between the transducers
- c = speed of sound

The wind speed, u_a , along any axis can be found by inverting the above relationships, then subtracting Eq. (B-2) from (B-1) and solving for u_a .

$$u_a = \frac{d}{2} \left[\frac{1}{t_o} - \frac{1}{t_b} \right] \quad (B-3)$$

The wind speed is measured on all three non-orthogonal axis to give u_a , u_b , and u_c , where the subscripts a, b, and c refer to the non-orthogonal sonic axis.

The non-orthogonal wind speed components are then transformed into orthogonal wind speed components, u_x , u_y , and u_z , with the following:

$$\begin{bmatrix} u_x \\ u_y \\ u_z \end{bmatrix} = A \begin{bmatrix} u_a \\ u_b \\ u_c \end{bmatrix} \quad (B-4)$$

where: A = a 3 x 3 coordinate transformation matrix, that is unique for each CSAT3B and is stored in ROM memory

B.1.2 Temperature

The sonically determined speed of sound is given in Eq. (B-5) and was found from the sum of the inverses of Eq. (B-1) and (B-2). The CSAT3B corrects online for the effect of wind blowing perpendicular to the sonic path. No additional off-line corrections are required as suggested by Liu et al., 2001.

$$c = \frac{d}{2} \left[\frac{1}{t_o} + \frac{1}{t_b} \right] \quad (\text{B-5})$$

The speed of sound in moist air is a function of temperature and humidity and is given by:

$$c^2 = \gamma P / \rho = \gamma R_d T_v = \gamma R_d T (1 + 0.61q) \quad (\text{B-6})$$

where: γ = ratio of specific heat of moist air at constant pressure to that at constant volume

P = pressure

ρ = air density

R_d = gas constant for dry air

T_v = virtual temperature

T = air temperature

q = specific humidity defined as the ratio of the mass of water vapor to the total mass of air (as in Kaimal and Gaynor, 1991; and Wallace and Hobbs, 1977)

Note that γ is a function of specific humidity. It would be convenient if the effects of humidity could be consolidated into one term.

The specific heats for moist air at constant pressure and volume are given by:

$$\begin{aligned} C_p &= qC_{pw} + (1-q)C_{pd} \\ &= C_{pd}(1 + 0.84q) \end{aligned} \quad (\text{B-7a})$$

$$\begin{aligned} C_v &= qC_{vw} + (1-q)C_{vd} \\ &= C_{vd}(1 + 0.93q) \end{aligned} \quad (\text{B-7b})$$

where: C_p and C_v = specific heats of moist air at constant volume and pressure

C_{pw} and C_{vw} = specific heat of water vapor

C_{pd} and C_{vd} = specific heat of dry air, respectively (Fleagle and Businger, 1980)

Substitute Eq. (B-7a) and (B-7b) into (B-6) and ignore the higher order terms. This yields

$$c^2 = \gamma_d R_d T_s = \gamma_d R_d T(1 + 0.51q) \quad (\text{B-8})$$

where: T_s = sonic virtual temperature

γ_d = ratio of specific heat of dry air at constant pressure to that at constant volume (Fleagle and Businger, 1980; Kaimal and Gaynor, 1991; Kaimal and Businger, 1963; Schotanus et al., 1983)

With Eq. (B-8), the effect of humidity, on the speed of sound, is included in the sonic virtual temperature.

The sonic virtual temperature, in degrees Celsius, is given by Eq. (B-9), where $\gamma_d = 1.4$ and $R_d = 287.04 \text{ JK}^{-1} \text{ kg}^{-1}$.

$$T_s = \frac{c^2}{\gamma_d R_d} - 273.15 \quad (\text{B-9})$$

B.2 References

- Kaimal, J. C. and Businger, J. A.: 1963, "A Continuous Wave Sonic Anemometer-Thermometer", *J. Applied Meteorol.*, **2**, 156-164.
- Kaimal, J. C. and Gaynor, J. E.: 1991, "Another Look at Sonic Thermometry", *Boundary-Layer Meteorol.*, **56**, 401-410.
- Fleagle, R. G. and Businger, J. A.: 1980, *An Introduction to Atmospheric Physics*, Academic Press, Inc., New York.
- Liu, H., Peters, G. and Foken, T.: 2001, "New Equations for Sonic Temperature Variance and Buoyancy Heat Flux with an Omnidirectional Sonic Anemometer", *Boundary-Layer Meteorol.*, **100**, 459-468.
- Schotanus, P., Nieuwstadt, F. T. M. and de Bruin, H. A. R.: 1983, "Temperature Measurement with a Sonic Anemometer and its Application to Heat and Moisture Fluxes", *Boundary-Layer Meteorol.*, **26**, 81-93.
- Wallace, J. M. and Hobbs, P. V.: 1977, *Atmospheric Science an Introductory Survey*, Academic Press, Inc., New York.

Appendix C. Example CRBasic Datalogger Programs

The following CRBasic examples cover the most common use cases of the CSAT3B.

C.1 Simple SDM Program

In this example, SDM communications are used to collect data from a single CSAT3B.

```
'-----  
' Define Constants, Variables, and Aliases  
'-----  
Const SDM_ADDR = 3      'SDM Address of Device  
  
Public CSATVals(5)  
Public CSATMonitorVals(4)  
  
Alias CSATVals(1) = Ux  
Alias CSATVals(2) = Uy  
Alias CSATVals(3) = Uz  
Alias CSATVals(4) = SonTemp  
Alias CSATVals(5) = Diag  
  
Alias CSATMonitorVals(1) = BoardTemp  
Alias CSATMonitorVals(2) = BoardHumidity  
Alias CSATMonitorVals(3) = InclinePitch  
Alias CSATMonitorVals(4) = InclineRoll  
  
'-----  
' Define Data Tables  
'-----  
DataTable (SonicData,1,-1)  
  Sample (5,CSATVals(1),IEEE4)  
EndTable  
  
DataTable (MonitorData,1,-1)  
  DataInterval (0,5,Sec,10)  
  Sample (4,CSATMonitorVals(1),IEEE4)  
EndTable  
  
'-----  
' Main Program  
'-----  
BeginProg  
  
  Scan(50,msec,500,0)      '20 Hz Scan  
  'CSAT3B(Destination, Bus, Address, OperatingMode)  
  CSAT3B(CSATVals(),0,SDM_ADDR,0)  
  CallTable(SonicData)  
  NextScan  
  
SlowSequence  
  
  Scan(5,sec,0,0)          '5 second scan  
  'CSAT3BMonitor (Destination, Bus, Address)  
  CSAT3BMonitor(CSATMonitorVals(),0,SDM_ADDR)  
  CallTable(MonitorData)  
  NextScan  
  
EndProg
```

C.2 Simple CPI Program

In this example, CPI communications are used to collect data from a single CSAT3B.

```

'-----
' Define Constants, Variables, and Aliases
'-----
Const CPI_ADDR = 30      'CPI Address of Device

Public CSATVals(5)
Public CSATMonitorVals(4)

Alias CSATVals(1) = Ux
Alias CSATVals(2) = Uy
Alias CSATVals(3) = Uz
Alias CSATVals(4) = SonTemp
Alias CSATVals(5) = Diag

Alias CSATMonitorVals(1) = BoardTemp
Alias CSATMonitorVals(2) = BoardHumidity
Alias CSATMonitorVals(3) = InclinePitch
Alias CSATMonitorVals(4) = InclineRoll

'-----
' Define Data Tables
'-----
DataTable (SonicData,1,-1)
  Sample (5,CSATVals(1),IEEE4)
EndTable

DataTable (MonitorData,1,-1)
  DataInterval (0,5,Sec,10)
  Sample (4,CSATMonitorVals(1),IEEE4)
EndTable

'-----
' Main Program
'-----
BeginProg

  Scan(50,msec,500,0)      '20 Hz Scan
  'CSAT3B(Destination, Bus, Address, OperatingMode)
  CSAT3B(CSATVals(),1,CPI_ADDR,0)
  CallTable(SonicData)
  NextScan

SlowSequence

  Scan(5,sec,0,0)          '5 second scan
  'CSAT3BMonitor(Destination, Bus, Address)
  CSAT3BMonitor(CSATMonitorVals(),1,CPI_ADDR)
  CallTable(MonitorData)
  NextScan

EndProg

```



```

Units Ts      = degC
Units diag    = unitless

'CSAT3B monitor outputs
Public monitor(4)
Alias monitor(1) = board_temp      'Board Temperature
Alias monitor(2) = board_humidity  'Board Relative Humidity
Alias monitor(3) = incline_pitch   'Inclinometer Pitch
Alias monitor(4) = incline_roll    'Inclinometer Roll
Units board_temp      = degC
Units board_humidity = percent
Units incline_pitch   = deg
Units incline_roll    = deg

'CSAT3B diagnostic flags
Public diag_bits(9) As Boolean
Alias diag_bits(1) = Flag_LowAmp   'Low Amplitude Flag
Alias diag_bits(2) = Flag_HighAmp  'High Amplitude Flag
Alias diag_bits(3) = Flag_Tracking 'Tracking Flag
Alias diag_bits(4) = Flag_HighDeltaC 'High Delta Speed of Sound Flag
Alias diag_bits(5) = Flag_Acq      'Acquiring Flag
Alias diag_bits(6) = Flag_LowVolt  'Low Supply Voltage Flag
Alias diag_bits(7) = Flag_MemErr   'Memory Error Flag
Alias diag_bits(8) = Flag_ADCSkip  'ADC Clock Error Flag
Alias diag_bits(9) = Flag_TrigErr  'Trigger Error Flag

'Wind directions and speed.
Public wind_out(8)
'Alias wind_out(1) = wind_spd - in compass coord system, same as CSAT3B
'Alias wind_out(2) = result_wind_speed - in compass coord system, same as CSAT3B
Alias wind_out(3) = wind_dir_compass
'Alias wind_out(4) = standard_wind_dir - in compass coord system, same as CSAT3B
Alias wind_out(5) = wind_speed
Alias wind_out(6) = result_wind_speed
Alias wind_out(7) = wind_dir_csat
Alias wind_out(8) = standard_wind_dir
Units wind_dir_compass = degrees
Units wind_speed       = m/s
Units result_wind_speed = m/s
Units wind_dir_csat    = degrees
Units standard_wind_dir = degrees

'Working variables.
Dim wind_east          'East wind in compass coordinate system
Dim wind_north        'North wind in compass coordinate system
Dim diag_integer As Long
Dim disable_stats(2) As Boolean 'Intermediate processing disable flags

'Other Variables
Public battery_volt
Units battery_volt = V
Public panel_temp
Units panel_temp = C

'-----
' Define Data Tables
'-----
' Original Sonic Data
DataTable (DataSonic,1,-1)
  Sample (5,wind(1),IEEE4)
EndTable

' Monitor Data
DataTable (DataMonitor,1,-1)
  DataInterval (0,MONITOR_INTERVAL,Sec,10)
  Sample (4,monitor(1),IEEE4)
EndTable

```

```

' Working Data
DataTable (DataWindVec,TRUE,1)
  DataInterval (0,STATS_INTERVAL,Min,2)
  'Compute wind direction from CSAT data.
  WindVector (1,wind_east,wind_north,IIEEE4,disable_stats(1),0,1,2)
  WindVector (1,Uy,Ux,IIEEE4,disable_stats(1),0,1,2)
EndTable

' Statistics data.
DataTable (DataStats,TRUE,-1)
  DataInterval (0,STATS_INTERVAL,Min,2)

  Average (1,Ts,IIEEE4,disable_stats(1))
  StdDev (1,Ts,IIEEE4,disable_stats(1))
  Average (1,Ux,IIEEE4,disable_stats(1))
  StdDev (1,Ux,IIEEE4,disable_stats(1))
  Average (1,Uy,IIEEE4,disable_stats(1))
  StdDev (1,Uy,IIEEE4,disable_stats(1))
  Average (1,Uz,IIEEE4,disable_stats(1))
  StdDev (1,Uz,IIEEE4,disable_stats(1))

  Sample (1,wind_dir_compass,IIEEE4)
  Sample (1,wind_dir_csat,IIEEE4)
  Sample (1,wind_speed,IIEEE4)
  Sample (1,result_wind_speed,IIEEE4)
  Sample (1,standard_wind_dir,IIEEE4)

  Totalize (1,N_STATS,IIEEE4,disable_stats(1))
  Totalize (1,N_STATS,IIEEE4,NOT (disable_stats(1) OR disable_stats(2)))
  FieldNames ("csat_warnings")
  Totalize (1,N_STATS,IIEEE4,NOT (Flag_LowAmp) OR NOT (disable_stats(2)))
  FieldNames ("Flag_LowAmp_Tot")
  Totalize (1,N_STATS,IIEEE4,NOT (Flag_HighAmp) OR NOT (disable_stats(2)))
  FieldNames ("Flag_HighAmp_Tot")
  Totalize (1,N_STATS,IIEEE4,NOT (Flag_Tracking) OR NOT (disable_stats(2)))
  FieldNames ("Flag_Tracking_Tot")
  Totalize (1,N_STATS,IIEEE4,NOT (Flag_HighDeltaC) OR NOT (disable_stats(2)))
  FieldNames ("Flag_HighDeltaC_Tot")
  Totalize (1,N_STATS,IIEEE4,NOT (Flag_Acq) OR NOT (disable_stats(2)))
  FieldNames ("Flag_Acq_Tot")
  Totalize (1,N_STATS,IIEEE4,NOT (Flag_LowVolt) OR NOT (disable_stats(2)))
  FieldNames ("Flag_LowVolt_Tot")
  Totalize (1,N_STATS,IIEEE4,NOT (Flag_MemErr) OR NOT (disable_stats(2)))
  FieldNames ("Flag_MemErr_Tot")
  Totalize (1,N_STATS,IIEEE4,NOT (Flag_ADCSkip) OR NOT (disable_stats(2)))
  FieldNames ("Flag_ADCSkip_Tot")
  Totalize (1,N_STATS,IIEEE4,NOT (Flag_TrigErr) OR NOT (disable_stats(2)))
  FieldNames ("Flag_TrigErr_Tot")

  Average (1,panel_temp,IIEEE4,FALSE)
  Average (1,battery_volt,IIEEE4,FALSE)
  Average (1,board_temp,IIEEE4,FALSE)
  Average (1,board_humidity,IIEEE4,FALSE)
  Average (1,incline_pitch,IIEEE4,FALSE)
  Average (1,incline_roll,IIEEE4,FALSE)
EndTable

'-----
' Main Program
'-----
BeginProg
  Move (Ux,5,NaN,1)           'Set all CSAT3B variables to NaN
  CPISpeed (CPI_RATE)        'Set the SDM clock speed

  Scan (SCAN_INTERVAL,mSec,500,0)

```

```

PanelTemp (panel_temp,250)      'Measure datalogger panel temperature
Battery (battery_volt)         'Measure battery voltage.

'CSAT3B(Destination, Bus, Address, OperatingMode)
CSAT3B(wind(),1,CPI_ADDR,0)

'Copy and convert CSAT3B for compass wind vector computation.
wind_east = -1*Uy
wind_north = Ux

'Break up the warning flags into separate bits.
diag_integer = diag
diag_bits(1) = diag_integer AND &h00000001
diag_bits(2) = diag_integer AND &h00000002
diag_bits(3) = diag_integer AND &h00000004
diag_bits(4) = diag_integer AND &h00000008
diag_bits(5) = diag_integer AND &h00000010
diag_bits(6) = diag_integer AND &h00000020
diag_bits(7) = diag_integer AND &h00000040
diag_bits(8) = diag_integer AND &h00000080
diag_bits(9) = diag_integer AND &h00000100

'Turn on this intermediate processing disable flag when any
'warning flag is set or the data returned is NaN
disable_stats(1) = ((diag_integer AND &hfffffff) OR (diag = NaN))
'Turn on this intermediate processing disable flag only when
'CSAT3B diagnostic warning flags are set
disable_stats(2) = ((diag_integer AND &hfffffff) AND NOT (diag = NaN))

'Compute the online wind vector statistics.
CallTable DataWindVec

If (DataWindVec.Output(1,1) ) Then
  GetRecord (wind_out(1),DataWindVec,1)
  'Compass wind direction will be 0 to 360 degrees.
  wind_dir_compass = (wind_dir_compass+CSAT_AZIMUTH) MOD 360
  'CSAT wind direction will be 0 to 180 or 0 to -180 degrees.
  If ( wind_dir_csat ) > 180 Then ( wind_dir_csat = wind_dir_csat-360 )
EndIf

CallTable DataSonic
CallTable DataStats
NextScan

SlowSequence

Scan(MONITOR_INTERVAL,sec,0,0)
'CSAT3BMonitor(Destination, Bus, Address)
CSAT3BMonitor(monitor(),1,CPI_ADDR)
CallTable(DataMonitor)
NextScan

EndProg

```

Campbell Scientific Companies

Campbell Scientific, Inc. (CSI)

815 West 1800 North
Logan, Utah 84321
UNITED STATES

www.campbellsci.com • info@campbellsci.com

Campbell Scientific Africa Pty. Ltd. (CSAf)

PO Box 2450
Somerset West 7129
SOUTH AFRICA

www.csafrica.co.za • cleroux@csafrica.co.za

Campbell Scientific Australia Pty. Ltd. (CSA)

PO Box 8108
Garbutt Post Shop QLD 4814
AUSTRALIA

www.campbellsci.com.au • info@campbellsci.com.au

Campbell Scientific (Beijing) Co., Ltd.

8B16, Floor 8 Tower B, Hanwei Plaza
7 Guanghua Road
Chaoyang, Beijing 100004
P.R. CHINA

www.campbellsci.com • info@campbellsci.com.cn

Campbell Scientific do Brasil Ltda. (CSB)

Rua Apinagés, nbr. 2018 — Perdizes
CEP: 01258-00 — São Paulo — SP
BRASIL

www.campbellsci.com.br • vendas@campbellsci.com.br

Campbell Scientific Canada Corp. (CSC)

14532 – 131 Avenue NW
Edmonton AB T5L 4X4
CANADA

www.campbellsci.ca • dataloggers@campbellsci.ca

Campbell Scientific Centro Caribe S.A. (CSCC)

300 N Cementerio, Edificio Breller
Santo Domingo, Heredia 40305
COSTA RICA

www.campbellsci.cc • info@campbellsci.cc

Campbell Scientific Ltd. (CSL)

Campbell Park
80 Hathern Road
Shepshed, Loughborough LE12 9GX
UNITED KINGDOM

www.campbellsci.co.uk • sales@campbellsci.co.uk

Campbell Scientific Ltd. (CSL France)

3 Avenue de la Division Leclerc
92160 ANTONY
FRANCE

www.campbellsci.fr • info@campbellsci.fr

Campbell Scientific Ltd. (CSL Germany)

Fahrenheitstraße 13
28359 Bremen
GERMANY

www.campbellsci.de • info@campbellsci.de

Campbell Scientific Spain, S. L. (CSL Spain)

Avda. Pompeu Fabra 7-9, local 1
08024 Barcelona
SPAIN

www.campbellsci.es • info@campbellsci.es

Please visit www.campbellsci.com to obtain contact information for your local US or international representative.