



**DOOLITTLE TRAILER MFG., INC.
DUMP, EQUIPMENT, UTILITY,
ENCLOSED
& DECKOVER TRAILERS**



WARNING

**This User's Manual Contains Safety Information And
Instructions For Your Trailer.**

**You Must Read This Manual Before Loading Or Towing
Your Trailer.**

You Must Follow All Safety Precautions And Instructions.

GENERAL INFORMATION

Table of Contents

1 WARRANTY.....

Warranty Information

- 1.1 Manufacturer's Warranty
- 1.2 Warranty Covers
- 1.3 Limitations
- 1.4 Warranty Void
- 1.5 Excluded Transportation Costs
- 1.6 Disclaimers
- 1.7 Dealer Responsibilities
- 1.8 Required Warranty Claim Procedure

2 GENERAL SAFETY INFORMATION.....

- 2.1 Safety Alert Symbols and Signal Words
- 2.2 Major Hazards
- 2.3 Improper Sizing of the Trailer to the Tow Vehicle
- 2.4 Driving Too Fast
- 2.5 Failure to Adjust Driving Behavior When Towing a Trailer
- 2.6 Trailer Not Properly Coupled to Hitch
- 2.7 Proper Use of Safety Chains
- 2.8 Proper Connection of Breakaway Brake
- 2.9 Matching Trailer and Hitch
- 2.10 Worn Tires, Loose Wheels and Lug Nuts
- 2.11 Improper Loading
- 2.12 Unsafe Load Distribution
- 2.13 Shifting Cargo
- 2.14 Inappropriate Cargo
- 2.15 Inoperable Breaks, Lights and Mirrors
- 2.16 Hazards from Modifying Your Trailer
- 2.17 Hazards for Dump Trailers
- 2.18 Hazards from Accessories
- 2.19 Safety Warning Labels on Your Trailer
- 2.20 Trailer Towing Guide
- 2.21 Safe Trailer Towing Guidelines
- 2.22 Reporting Safety Defects

3 TIRE SAFETY INFORMATION.....

- 3.1 Trailer Tire Information
- 3.2 Steps for Determining Correct Load Limit- Trailer
 - 3.2.1 Trailer 10,000 Pounds of GVWR or Less
 - 3.2.2 Trailer over 10,000 Pounds GVWR

GENERAL INFORMATION

- 3.3 Steps for Determining Correct Load Limit- Tow Vehicle
- 3.4 Glossary of Tire Terminology
- 3.5 Tire Safety-Everything Rides on It
 - 3.5.1 Basic Tire Maintenance
 - 3.5.2 Finding Your Vehicles Recommended Tire Pressure and Load Limits
 - 3.5.3 Understanding Tire Pressure and Load Limits
 - 3.5.4 Checking Tire Pressure
 - 3.5.5 Steps for Maintaining Proper Tire Pressure
 - 3.5.6 Tire Size
 - 3.5.7 Tire Tread
 - 3.5.8 Tire Balance and Wheel Alignment
 - 3.5.9 Tire Repair
 - 3.5.10 Tire Fundamentals
 - 3.5.10.1 Information on Passenger Vehicle Tires
 - 3.5.10.2 UTQGS Information
 - 3.5.10.3 Additional Information on Light Truck Tires
 - 3.5.11 Tire Safety Tips

4 COUPLING TO THE TOW VEHICLE.....

- 4.1 Use an Adequate Tow Vehicle and Hitch
 - 4.1.1 Trailer Information
 - 4.1.2 Tow Vehicle
- 4.2 Coupling and Uncoupling the Trailer
 - 4.2.1 Various Coupler Designs
- 4.3 Bumper Pull Trailers
 - 4.3.1 Trailer with Ball Hitch Coupler
 - 4.3.1.1 Before Coupling the Trailer to the Tow Vehicle
 - 4.3.1.2 Prepare the Coupler and Hitch
 - 4.3.1.3 Couple the Trailer to the Tow Vehicle
 - 4.3.2 Trailer with Ring and Pintle Coupler
 - 4.3.2.1 Before Coupling the Trailer to the Tow Vehicle
 - 4.3.2.2 Prepare the Ring and Pintle
 - 4.3.2.3 Couple the Trailer to the Tow Vehicle
 - 4.3.3 Rig the Safety Chains- Bumper Pull Trailers
 - 4.3.4 Connect the Electrical Cable- Bumper Pull Trailers
 - 4.3.5 Attach the Test Electric Breakaway Brake System- Bumper Pull Trailers
 - 4.3.6 Uncoupling Bumper Pull Trailer
- 4.4 Trailer with Gooseneck Coupler
 - 4.4.1 Before Coupling the Trailer to the Tow Vehicle

GENERAL INFORMATION

- 4.4.2 Prepare the Ball Receiver and Gooseneck Ball
- 4.4.3 Couple the Trailer to the Tow Vehicle
- 4.4.4 Rig the Safety Chains
- 4.4.5 Connect the Electrical Cable
- 4.4.6 Attach and Test the Breakaway Brake System
- 4.4.7 Uncoupling Gooseneck Trailer with Ball Coupler
- 4.5 Trailer with Fifth Wheel Coupler and Drop-Leg Jack
 - 4.5.1 Before Attempting to Tow the Trailer
 - 4.5.2 Raise the Drop Leg Jack
 - 4.5.3 Connect the Electrical Cables
 - 4.5.4 Attach and Test the Breakaway Brake System
 - 4.5.5 Uncoupling the Fifth Wheel Trailer with Drop Leg Jack
- 4.6 Tongue Weight
- 4.7 Checking Tongue Weight

5 LOADING AND UNLOADING A DUMP TRAILER.....

- 5.1 Loading an Enclosed Trailer
 - 5.1.1 Prepare Trailer for Loading

6 CHECKING THE TRAILER BEFORE AND DURING EACH TOW.....

- 6.1 Pre-Tow Checklist
- 6.2 Make Regular Stops

7 ACCESSORIES.....

- 7.1 Accessories
- 7.2 Gasoline – Powered Electric Generator
- 7.3 Accessory Battery
- 7.4 Shore Power
- 7.5 LP Gas Fuel System
- 7.6 LP Gas System Troubleshooting
- 7.7 Vending and Accessory Doors
- 7.8 Electric Powered Landing Gear

8 INSPECTION, SERVICE, & MAINTENANCE.....

- 8.1 Inspection, Service, & Maintenance Summary Charts
- 8.2 Inspections and Service Instructions
 - 8.2.1 Axle Bolts, Frame, Suspension, & Structure
 - 8.2.2 Trailer Structure
 - 8.2.2.1 Fasteners and Frame Members
 - 8.2.2.2 Welds
 - 8.2.2.3 Brake Shoes and Drums

- 8.2.2.4 Manually Adjusting Brake Shoes
- 8.2.3 Breakaway Brakes
 - 8.2.3.1 Breakaway Battery
 - 8.2.3.2 Breakaway Switch
- 8.2.4 Tow Vehicle Operated Electric Brakes
- 8.2.5 Magnets for all Electric Brakes
- 8.2.6 Hydraulic Brakes (vacuum, air, or electric operated)
- 8.2.7 Air Pressure-Operated Hydraulics
- 8.2.8 Electrical Operated Hydraulics

9 CONNECTIONS TO A TOW VEHICLE.....

- 9.1 Bumper Pull Coupler and Ball
 - 9.1.1 Ring and Pintle
 - 9.1.2 Gooseneck Ball Receiver
 - 9.1.3 Landing Leg or Jack
 - 9.1.4 Lights and Signals
 - 9.1.5 Tires
 - 9.1.6 Wheel Rims
 - 9.1.7 Lubrication Points- Dump Trailers

WARRANTY

Warranty Information

1.1 MANUFACTURER'S WARRANTY

Doolittle Trailers warrants that its product to the original purchaser will be free of structural defects(s) for a period of five (5) years, providing that the following conditions are met and satisfied.

1.2 WARRANTY COVERS

This one (5) year warranty covers the main frame, ramps, cross members, railing and sub-frame only. Normal wear items will not be replaced due to wear. These normal wear items include but are not limited to flooring, paint, brake lining(s), bearing and hoses. All auxiliary parts such as brakes, calipers, jacks, wheels, bearings, tires, suspension, lights, hydraulic dump cylinder and controls are covered by the warranty of their manufacturer.

1.3 LIMITATIONS

The sole responsibility of Doolittle Trailers under this limited warranty shall be to repair and replace parts at the Doolittle Trailer factory, or at a Doolittle Trailer Mfg., Inc. authorized dealer, or another location (with prior written approval by Doolittle Trailers). All other obligations or liabilities, including incidental or consequential damages or contingent liabilities arising out of the failure of any parts to operate properly are hereby excluded, including but not limited to any damages resulting from loss of use, inconvenience, loss of time, commercial loss, or any other type of damages general or specific, foreseen or unforeseen, unless applicable state law provides otherwise. Doolittle Trailers will not reimburse any claimant for any adjustment or repair of a Doolittle Trailer without prior written approval by Doolittle Trailers. Any repairs performed at a location other than Doolittle Trailer Mfg., Inc., will be allotted \$60 per hour for labor costs.

1.4 WARRANTY VOID

Doolittle Trailers is not responsible for damage caused by accident, negligence, abuse, misapplication, or misuse of a trailer or any of its component parts. Loading in excess of gross vehicle load rating stated on the certificate plate will invalidate all warranties. Any modifications, alterations, or repair to any product manufactured by Doolittle Trailer Mfg., Inc without Doolittle Trailers prior knowledge and written consent will void manufacturer's warranty.

1.5 EXCLUDED TRANSPORTATION COSTS

Transportation of any trailer to and/or from your dealer, or approved repair facility, or Doolittle Trailers factory shall be the responsibility of the trailer owner. Doolittle Trailers shall not be held responsible for any such costs.

1.6 DISCLAIMERS

This warranty is expressly given in lieu of all other warranties and representations. Doolittle Trailers makes no representation or warranty of any kind, express or implied, with respect to Doolittle

WARRANTY

Trailers weather as to merchantability, fitness or a purpose of any other matter. No one, including an authorized Doolittle Trailer dealer is authorized to make further or additional warranties on behalf of Doolittle Trailer Mfg., Inc.

1.7 DEALER RESPONSIBILITIES

The dealer is responsible for submitting the manufacturer any claim you wish to make under this Limited Warranty.

1.8 REQUIRED WARRANTY CLAIM PROCEDURE

1. Within five (5) days after discovering a problem with your Doolittle Trailers trailer, return your trailer for inspection to your Doolittle Trailer dealer where you bought your trailer.
2. If your dealer cannot repair the problem free of charge and you want to file a claim under this warranty, your local dealer must send to Doolittle Trailers by registered letter, fax or email a warranty claim form, together with all the required information within ten (10) days of the discovery of your defect.
3. Doolittle Trailers will acknowledge such receipt of a claim by registered letter or fax or email to the dealer and the claimant. Doolittle Trailers will respond as soon as possible, being later than thirty (30) days after the receipt of the claim.
4. Any defected parts must be sent by prepaid freight to Doolittle Trailers if it is requested, to be able to qualify the claimant for replacement or reimbursement under this limited warranty. Any defective parts must be returned to Doolittle Trailers WITHIN THIRTY (30) DAYS OF THE DATE OF APPROVAL TO QUALIFY FOR REIMBURSEMENT.
5. Doolittle Trailers reserves the right to not pay unreasonable cost for replacement or repair of defects to a Doolittle Trailers trailer and may at its discretion; establish reasonable reimbursement or parts for any authorized work performed under the terms of this Limited Warranty.
6. When required, photos of defective part(s), or the actual part(s), may have to accompany the warranty approval before payment can or will be made.
7. Doolittle Trailers HERE MAKES NO OTHER EXPRESS OR IMPLIED WARRANTIES AND THERE ARE NO OTHER WARRANTIES WHICH EXTEND BEYOND THOSE DESCRIBED IN THE USER'S MANUAL.

GENERAL SAFETY INFORMATION

2.1 SAFETY ALERT SYMBOLS AND SIGNAL WORDS

An Owner's Manual that provides general trailer information cannot cover all the specific details necessary for the proper combination of every trailer, tow vehicle and hitch. Therefore, you must read, understand and follow the instructions given by the tow vehicle and hitch. Therefore, you must read, understand and follow the instructions given by the tow vehicle and trailer hitch manufacturers, as well as the instructions in this manual. Other trailers are built with components produced by various manufacturers. Some of these items have separate instruction manuals. Where this manual indicates that you should read another manual, and you do not have that manual call Doolittle Trailers at 800-654-4948 for a free copy.

The safety information in this manual is denoted by the safety alert symbol:

 The level of risk is indicated by the following signal words.

 **DANGER**

DANGER- Immediate hazards which WILL result in severe personal injury or death if the warning is ignored.

 **WARNING**

WARNING- Hazards or unsafe practices which COULD result in severe personal injury or death if the warning is ignored.

 **CAUTION**

CAUTION- Hazards or unsafe practices which could result in minor or moderate injury if the warning is ignored.

NOTICE

NOTICE- Practices that could result in damage to the trailer or other property.

GENERAL SAFETY INFORMATION

2.2 MAJOR HAZARDS

Loss of control of the trailer or trailer/tow vehicle combination can result in death or serious injury. The most common causes for loss of control of the trailer are:

- Improper sizing the trailer for the tow vehicle, or vice versa.
- Excessive Speed- Driving too fast for the conditions
- Failure to adjust driving behavior when towing a trailer
- Overloading and/or improper weight distribution
- Improper or mis-coupling of the trailer to the hitch
- Improper braking and steering under sway conditions
- Not maintaining proper tire pressure
- Not keeping lug nuts tight

2.2.1 Improper Sizing of the Trailer to the Tow Vehicle

Trailers that weigh too much for the towing vehicle can cause stability problems, which can lead to death or serious injury. Furthermore, the additional strain put on the engine and drive-train may lead to serious tow vehicle maintenance problems. For these reasons the maximum towing capacity of your towing vehicle should not be exceeded. The towing capacity of your tow vehicle, in terms of maximum Gross Trailer Weight (GTW) and maximum Gross Combined Weight Rating (GCWR) can be found in the Tow truck vehicles Owner's Manual.

DANGER

Use of an under-rated hitch, ball or tow vehicle can result in the loss of control leading to death or serious injury. Make certain your hitch and tow vehicle are rated for your trailer.

2.2.2 Driving Too Fast

With ideal road conditions, the maximum recommended speed for safely towing a trailer is 60 mph. If you drive too fast, the trailer is more likely to sway, thus increasing the possibility for loss of control. Also, your tires may overheat, this increasing the possibility of a blowout.

WARNING

Driving too fast for conditions can result in loss of control and cause death or serious injury. Adjust speed down when towing trailer.

2.3 FAILURE TO ADJUST DRIVING BEHAVIOR WHEN TOWING A TRAILER

When towing a trailer, you will have decreased acceleration, increased stopping distance, and increased turning radius (which means you must make wider turns to keep from hitting curbs, vehicles, and anything else that is on the inside corner). Furthermore, the trailer will change the handling characteristics of your towing vehicle, making it more sensitive to steering inputs and more likely to be pushed around in windy conditions or when being passed by large vehicles. In addition, you will need a longer distance to pass, due to slower acceleration and increased length. With this in mind:

GENERAL SAFETY INFORMATION

- Be alert for slippery conditions. You are more likely to be affected by slippery road surfaces when driving a tow vehicle with a trailer, than driving a tow vehicle without a trailer
- Anticipate the trailer “swaying”. Swaying can be caused by excessive steering, wind gusts, roadway edges, or by the trailer reaction to the pressure wave created by passing trucks and busses. When encountering trailer sway take your foot off the gas, and steer as little as possible so it can stay on the road. Use small “trim-like” steering adjustments. Do not attempt to steer out of the sway: you will only make it worse. Also, do not apply the tow vehicle brakes to correct trailer swaying. On the other hand, application of the trailer brakes alone will tend to straighten out the combination, especially when going downhill
- Check rearview mirrors frequently to observe the trailer and traffic
- Use lower gear when driving down steep or long grades. Use the engine and transmission as a brake. Do not ride the brakes, as they can overheat and become ineffective
- Be aware of your trailer height, especially when approaching bridges, roofed areas and around trees

2.4 TRAILER NOT PROPERLY COUPLED TO THE HITCH

It is critical that the trailer be securely coupled to the hitch, and that the safety chains and emergency breakaway brake lanyard are correctly attached. Uncoupling may result in death or serious injury to you and others.

WARNING

Proper selection and condition of the coupler and hitch are essential to safely towing your trailer. A loss of coupling may result in death or serious injury.

- **Be sure the hitch load rating is equal to or greater than the load rating of the coupler.**
- **Be sure hitch size matches the coupler size.**
- **Observe the hitch for wear, corrosion and cracks before coupling. Replace worn, corroded or cracked hitch components before coupling the trailer to tow vehicle.**
- **Be sure the hitch components are tight before coupling the trailer to the tow vehicle.**

WARNING

An improperly coupled trailer can result in death or serious injury.

Do not move the trailer until:

- **The coupler is secured and locked to hitch;**
- **The safety chains are secured to the tow vehicle; and**
- **The trailer jack(s) are fully retracted.**

Do not tow the trailer on the road until:

- **Tires and wheels are checked;**
- **The trailer brakes are checked;**
- **The breakaway switch is connected to the tow vehicle;**
- **The load is secured to the trailer; and**
- **The trailer lights are connected and checked.**

GENERAL SAFETY INFORMATION

2.5. PROPER USE OF SAFETY CHAINS

If your trailer comes loose from the hitch for any reason, we have provided safety chains so that control of the trailer can still be maintained.



WARNING

Improper rigging of the safety chains can result in loss of control of the trailer and tow vehicle, leading to death or serious injury, if the trailer uncouples from tow vehicle.

- **Fasten chains to frame of tow vehicle. Do not fasten chains to any part of the hitch unless the hitch has holes or loops specifically for that purpose.**
- **Cross chains underneath hitch and coupler with enough slack to permit turning and to hold tongue up, if the trailer comes loose.**

2.6 PROPER CONNECTION OF BREAKAWAY BRAKE

If equipped with brakes your trailer will be equipped with a breakaway brake system that can apply the brakes on your trailer if your trailer comes loose from the hitch for any reason. You will have a separate set of instructions for the breakaway brake if your trailer is so equipped. The breakaway brake system, including battery, must be in good condition and properly rigged to be effective.



WARNING

An effective or inoperative breakaway system can result in a runaway trailer, leading to death or serious injury if the coupler or hitch fails

The breakaway lanyard must be connected to the tow vehicle, and not to any part of the hitch. Before towing the trailer, test the function of the breakaway brake system. If the breakaway brake system is not working, do not tow the trailer, have it serviced or repaired.

2.7 MATCHING TRAILER AND HITCH



DANGER

Use of hitch with a load rating less than the load rating of the trailer can result in loss of control and may lead to death or serious injury.

Use of a tow vehicle with a towing capacity less than the load rating of the trailer can result in loss of control and may lead to death or serious injury.

Be sure your hitch and tow vehicle are rated for the Gross Vehicle Weight Rating (GVWR) of your trailer.

GENERAL SAFETY INFORMATION

2.8 WORN TIRES, LOOSE WHEELS, AND LUG NUTS

- Just as your tow vehicle the trailer tires and wheels are important safety items. Therefore, it is essential to inspect the trailer tires before each tow.
- If a tire has a bald spot, bulge, cut, cracks or is showing any cords replace the tire before towing. If a tire has uneven tread wear, take the trailer to a dealer service center for diagnosis. Uneven tread wear can be caused by tire imbalance, axle misalignment or incorrect inflation.
- Tires with too little tread will not provide adequate frictional forces on wet roadways and can result in loss of control, leading to death or serious injury.
- Improper tire pressure causes increased tire wear and may reduce trailer stability, which can result in a tire blowout or possible loss of control.

Therefore, before each tow you must also check tire pressure. Remember, the proper tire pressure is listed on the Certification/VIN label, normally mounted on the front left side of the trailer and should be checked when tires are cold. Allow 3 hours cool-down after driving as much as 1 mile at 40 mph before checking tire pressure.

WARNING

Improper tire pressure may cause unstable trailer. Blowout and loss of control may occur. Death or serious injury can result.

Make sure of proper tire pressure before towing trailer. Inflate tires to pressure stated on the Certification/VIN label.

The tightness of the lug nuts is very important in keeping the wheels properly seated to the hub. Before each tow, check to make sure they are tight.

WARNING

Metal creep between the wheel rim and lug nuts (bolts) will cause rim to loosen.

Death or injury can occur if wheel comes off.

Tighten lug nuts (bolts) before each tow.

The proper tightness (torque) for lug nuts and tightening sequence is listed in Section 10.2.12 of this manual. Use a torque wrench to tighten the lug nuts and use the crisscross star pattern sequence. Lug nuts are also prone to loosen after first being assembled. When driving a new trailer (or after wheels have been remounted), check to make sure they are tight after the first 10, 25, and 50 miles of driving and before each tow thereafter. Failure to perform this check can result in a wheel separating from the trailer and a crash, leading to death or serious injury.

GENERAL SAFETY INFORMATION

WARNING

Lug nuts are prone to loosen after being first assembled. Death or serious injury can result.

Check lug nuts for tightness on a new trailer, and after re-mounting a wheel at 10, 25 and 50 miles.

WARNING

Inadequate lug nut torque can cause a wheel to separate from the trailer, leading to death or serious injury.

Be sure lug nuts are tight before each tow.

2.9 IMPROPER LOADING

The total weight of the load you put in or on the trailer, plus the empty weight of the trailer itself, must not exceed the trailer's Gross Vehicle Weight Rating (GVWR). If you do not know the empty weight of the trailer plus the cargo weight, you must weigh the loaded trailer at a commercial scale. In addition, you must distribute the load in the trailer such that the load on any axle does not exceed the Gross Axle Weight Rating (GAWR). If your trailer is equipped with a Tire & Loading Information Placard, mounted next to the Certification / VIN label, the cargo capacity weight stated on the placard is only a close estimate. The GVWR and GAWR's are listed on the Certification / VIN label mounted on the front left side of the trailer.

WARNING

An overloaded trailer can result in failure or loss of control of the trailer, leading to death or serious injury.

Never load a trailer so that the weight on any tire exceeds its rating.

Never exceed the trailer Gross Vehicle Weight Rating (GVWR).

Never exceed an axle Gross Axle Weight Rating (GAWR).

2.10 UNSAFE LOAD DISTRIBUTION

Improper front/rear load distribution can lead to poor trailer sway stability or poor tow vehicle handling. Poor trailer sway stability results from tongue weights that are too low, and poor tow vehicle stability results from tongue weights that are too high. Refer to the chapter heading "Loading the Trailer" for more information. In the following table, the second column shows the rule of thumb percentage of total weight of the trailer plus its cargo (Gross Trailer Weight., or "GTW") that should appear on the tongue of the trailer. For example, a trailer with a gooseneck hitch, with a loaded weight of 12,000 pounds, should have 20-25% of 12,000 pounds (2400-3000 lbs.) on the gooseneck.

A dump trailer will have the proper weight distribution if the load is evenly distributed in the dump body. For non-flow able (discrete) loads locate the load such as to provide the proper tongue weight. After loading, be sure to check that none of the axles are overloaded.

GENERAL SAFETY INFORMATION

TONGUE WEIGHT AS A PERCENTAGE OF LOADED TRAILER WEIGHT	
<u>TYPE OF HITCH</u>	<u>PERCENTAGE</u>
Ball Hitch (or Bumper Hitch)	10-15% for large trailers
	6-10% for smaller utility trailers
Gooseneck Hitch	20-25%
Fifth Wheel Hitch	

Uneven left / right load distribution can cause tire, wheel, axle or structural failure. Be sure your trailer is evenly loaded left / right. Towing stability also depends on keeping the center of gravity as low as possible.

WARNING

Improper tongue weight (load distribution) can result in loss of control of the trailer, leading to death or serious injury,

**Make certain that tongue weight is within the allowable range.
Be sure to:**

- **Distribute the load front-to-rear to provide proper tongue weight (see chart). For dump trailers, a flow-able load should be evenly distributed throughout the body.**
- **Distribute the load evenly, right and left.**
- **Keep the center of gravity low.**

2.11 SHIFTING CARGO

Since the trailer “ride” can be bumpy and rough, you must secure your cargo so that it does not shift while the trailer is being towed.

WARNING

A shifting load can result in failure, or to loss of control of the trailer, and can lead to death or serious injury.

You must tie down all loads with proper sized fasteners, ropes, straps, etc. to prevent the load from shifting while trailering.

If the door latch is equipped with a catch that has a hole for a linchpin, use a linchpin to prevent the door latch from opening.

GENERAL SAFETY INFORMATION

WARNING

If the door opens, your cargo may be ejected onto the road, resulting in death or serious injury to other drivers.

Always secure the door latch after closing. Place a linchpin in the latch.

WARNING

Engage deadbolt lock when towing trailer to prevent accidental door opening when in transit.

2.12 INAPPROPRIATE CARGO

Your trailer may be designed for specific cargo, for example, only for horses. If your trailer is designed for specific cargo, only carry that cargo in the trailer. A trailer must not be used to carry certain items, such as people, containers of hazardous substances or containers of flammable substances.

WARNING

Never transport people inside your trailer. Besides putting their lives at risk, the transport of people may be illegal.

2.13 INOPERABLE BRAKES, LIGHTS, OR MIRRORS

Be sure that the electric brakes and each of the lights on your trailer are functioning properly before towing your trailer. Electric brakes and lights on a trailer are controlled via a connection to the tow vehicle, generally a multi-pin electrical connector. Check the trailer tail lights by turning on your tow vehicle headlights. Check the trailer brake lights by having someone step on the tow vehicle brake pedal while you look at the trailer lights. Do the same thing to check the turn signal lights.

If your trailer has electric brakes, your tow vehicle will have an electric brake controller that sends power to the trailer brakes. Before towing the trailer on the road, you must operate the brake controller while attempting to pull that trailer. This is to confirm that the electric brakes operate. While towing the trailer at less than 5 mph, manually operate the electric brake controller in the tow vehicle cab. You should feel the operation of the trailer brakes.

If your trailer has hydraulic “surge” brakes, pull the emergency break-away brake lanyard to check the operation of the surge mechanism.

GENERAL SAFETY INFORMATION

Improper electrical connection between the tow vehicle and the trailer will result in inoperable lights as well as electric brakes. This could possibly result in collision.

Before each tow:

- **Check that all lights and turn signals work.**
- **Check that the electric brakes work by operating the brake controller inside the tow vehicle.**

Standard mirrors usually do not provide adequate visibility for viewing traffic to the sides and rear a towed trailer. You must provide mirrors that allow you to safely observe approaching traffic.

2.14 HAZARDS FROM MODIFYING YOUR TRAILER

Before making any alteration to your trailer, contact your dealer or Doolittle Trailers at 800-654-4948 and describe the alteration you are contemplating. Alteration of the trailer structure or modification of your trailer must be approved and performed only by qualified technicians who are familiar with your trailer.

2.15 HAZARDS FOR DUMP TRAILERS

A dump trailer is specifically designed for hauling cargo that is to be dumped or in some cases, transporting equipment. A dump trailer is not designed for transporting livestock. The major hazards associated with dump trailers are:

- Overloading, improper weight distribution, both side to side and front to back
- Getting under a raised dump body
- Not using or improperly using the body prop
- Modifying or altering hydraulic components
- Modifying or altering dump controls
- Not dumping from a solid and level foundation
- Not fully opening rear doors when dumping
- Jerking the trailer, or hydraulics, to loosen the load
- Trailer contacting or coming near overhead power lines when body is raised

WARNING

A soft or uneven surface may cause the tow vehicle and trailer to tip over when the dump body is raised.

Raise dump body ONLY if the tow vehicle and trailer are both on a firm level surface.

GENERAL SAFETY INFORMATION

WARNING

Risk of electrocution.

- Dump body coming near or contacting power lines can cause electrocution. Electrocution can occur without contact
- Be sure there are no overhead power lines over or near the trailer before raising dump body

WARNING

An overloaded trailer or improperly distributed load can result in death or serious injury.

An overloaded trailer can cause the hydraulic system to malfunction, resulting in the dump body falling.

A load that is improperly distributed in the trailer can result in the trailer tipping over when the dump body is raised.

DANGER

NEVER alter or substitute any hydraulic system component. Death or serious injury may result.

An altered component substituted hydraulic system may malfunction, resulting in the dump body falling without warning.

NEVER alter or substitute any hydraulic system component.

2.16 HAZARDS FROM ACCESSORIES

The “Accessories” chapter of this manual contains some information about certain optional accessories that may be on your trailer. Read and follow all the instructions before operating the accessories.

2.17 SAFETY WARNING LABELS ON YOUR TRAILER

WARNING

To protect you and others against death or serious injury, all the labels shown must be on the trailer and must be legible.

If any of these labels are missing or cannot be read, call Doolittle trailers at 800-654-4948 for replacement labels.

You will need to provide us with the number shown at the bottom of the label(s) so that we may send the correct one(s).

GENERAL SAFETY INFORMATION

2.18 TRAILER TOWING GUIDE

Driving a vehicle with a trailer in tow is vastly different from driving the same vehicle without the trailer in tow. Acceleration, maneuverability and braking are all diminished with a trailer in tow. It takes longer to get up to speed; you need more room to turn and pass, and more distance to stop when towing a trailer. You will need more room to turn and pass, and more distance to stop when towing a trailer. You will need to spend time adjusting to the different feel and maneuverability when towing a trailer, the hazards and risks of injury are also much greater than when driving without a trailer. You are responsible for keeping your vehicle and trailer in control, and for all the damage that is caused if you lose control of your vehicle and trailer.

As you did when learning to drive an automobile, find an open area with little or no traffic for your first practice trailering. Of course, before you start towing a trailer, you must follow all the instructions for inspection, testing, loading and coupling. Also, before you start towing, adjust the mirrors so you can see the trailer as well as the area to the rear of it.

Drive slowly at first, 5mph or so, and turn the wheel to get the feel of how the tow vehicle and trailer combination responds. Next, make some right and left-hand turns. Watch in your side mirrors to see how the trailer follows the tow vehicle. Turning with a trailer attached requires more room.

Stop the rig a few times from speeds no greater than 10 mph. If your trailer is equipped with brakes, try using different combinations of trailer/electric brake and tow vehicle brake. Note the effect that the trailer brakes have when they are the only brakes used. When properly adjusted, the trailer brakes will come on just before the tow vehicle brakes.

It will take practice to learn how to back up a tow vehicle with a trailer attached. Take it slow. Before backing up, get out of the tow vehicle and look behind the trailer to make sure that there are no obstacles. Some drivers place their hands at the bottom of the steering wheel, and while the tow vehicle is in reverse, “think” of the hands as being the top of the steering wheel. When the hands move to the right (counter-clockwise, as you would do to turn the vehicle left when moving forward), the rear of the trailer moves to the right. Conversely, rotating the steering wheel clockwise with your hands as the bottom of the wheel will move the rear of the trailer to the left, while backing up. If you are towing a bumper hitch rig, be careful not to allow the trailer to turn too much, because it will hit the rear of the tow vehicle. To straighten the rig, either pull forward, or turn the steering wheel in the opposite direction.

2.19 SAFE TRAILER TOWING GUIDELINES

- Recheck the load tie downs to make sure the load will not shift during towing
- Before towing, check coupling, safety chain, safety brake, tires, wheels and lights
- Check the lug nuts or bolts for tightness. Refer to Section 10.2.12
- Check coupler tightness after towing 50 miles
- Adjust the brake controller to engage the trailer brakes before the tow vehicle brakes. Follow the instructions given with the brake controller manufacturer’s literature
- Use your mirrors to verify that you have room to change lanes or pull into traffic
- Use your turn signals well in advance
- Allow plenty of stopping space for your trailer and tow vehicle
- Do not drive so fast that the trailer begins to sway due to speed. Generally, never drive faster than 60 m.p.h.
- Allow plenty of room for passing. A rule of thumb is that the passing distance with a trailer is 4 times the passing distance without a trailer
- Shift your automatic transmission into a lower gear for city driving
- Use lower gears for climbing and descending grades

GENERAL SAFETY INFORMATION

- Do not ride the brakes while descending grades; they may get so hot that they stop working. Then you will potentially have a runaway tow vehicle and trailer
- To conserve fuel, don't use full throttle to climb a hill. Instead, build speed on the approach
- Slow down for bumps in the road. Take your foot off the brake when crossing the bump
- Do not brake while in a curve unless it is absolutely, necessary. Instead, slow down before you enter the curve
- Do not apply the tow vehicle brakes to correct extreme trailer swaying. Instead, lightly apply the trailer brakes with the hand controller
- Make regular stops, about once each hour. Confirm that:
 - The coupler is secure to the hitch and is locked
 - Electrical Connectors are made
 - There is appropriate slack in the safety chains
 - There is appropriate slack in the breakaway switch pull pin cable,
 - The tires are not visibly low on pressure
 - The cargo is secure and in good condition

2.20 REPORTING SAFETY DEFECTS

If you believe that your vehicle has a defect that could cause a crash or could cause injury or death, you should immediately inform the National Highway Traffic Administration (NHTSA) in addition to notifying us. If NHTSA receives similar complaints, it may open an investigation, and if it finds that a safety defect exists in a group of vehicles, it may order a recall and remedy campaign. However, NHTSA cannot become involved in individual problems between you, your dealer, or us.

To contact NHTSA, you may call the Vehicle Safety Hotline toll-free at 1-888-327-4236 (TTY: 1-800-424-9153); or go to <http://www.safercar.gov>; or write to : Administrator, NHTSA, 400 Seventh Street SW, Washington, DC 20590. You can also obtain other information about motor vehicle safety from <http://www.safercar.gov>.

Call 800-654-4948 to reach Doolittle Trailer Mfg., Inc.

TIRE SAFETY INFORMATION

This portion of the User's Manual contains tire safety information as required by 49 CFR 575.6.

Section 2.1 contains "Trailer Information".

Section 2.2 contains "Steps for Determining Correct Load Limit-Trailer".

Section 2.3 contains "Steps for Determining Correct Load Limit-Tow Vehicle".

Section 2.4 contains a "Glossary of Tire Terminology", including "cold inflation pressure", "maximum inflation pressure", "recommended inflation pressure", and other non-technical terms.

Section 2.5 contains information from the NHTSA brochure entitled "Tire Safety-Everything Rides on It".

This brochure, as well as the preceding subsections, describe the following items:

- Tire labeling, including a description and explanation of each marking on the tires, and information about the DOT Tire Identification Number (TIN).

- Recommended tire inflation pressure, including a description and explanation of:

- A. Cold Inflation Pressure
- B. Vehicle Placard and location on vehicle
- C. Adverse safety consequences of under inflation (including tire failure)
- D. Measuring and adjusting air pressure for proper inflation.

- Tire Care, including maintenance and safety practices.

- Vehicle load limits, including a description and explanation of the following items:

- A. Locating and understanding the load limit information, total load capacity, and cargo capacity.
- B. Calculating total and cargo capacities with varying seating configurations including quantitative examples showing / illustrating how the vehicles cargo and luggage capacity decreases, as combined number and size of occupants' increases. This item is also discussed in Section 3.
- C. Determining compatibility of tire and vehicle load capabilities.
- D. Adverse safety consequences of overloading on handling and stopping on tires.

3.1 TRAILER TIRE INFORMATION

Trailer tires may be worn out even though they still have plenty of tread left. This is because trailer tires must carry a lot of weight all the time, even when not in use. It is better for the tire to be rolling down the road than to be idle. During use, the tire releases lubricants that are beneficial to tire life. Using the trailer tires often also helps prevent flat spots from developing.

The main cause of tire failure is improper inflation. Check the cold tire inflation pressures at least once a week for proper inflation levels. "Cold" means that the tires are at the same temperature as the surrounding air, such as when the vehicle has been parked overnight. Wheel and tire manufacturers recommend adjusting the air pressure to the trailer manufacturer recommended cold inflation pressure, in pounds per square inch (PSI) stated on the vehicle's Federal Certification Label or Tire Placard when the trailer is loaded to its gross vehicle weight rating (GVWR). If the tires are inflated to less than the recommended inflation level or the GVWR of the trailer is exceeded, the load carrying capacity of the tire could be dramatically affected. If the tires are inflated more than the recommended inflation level, handling characteristics of the tow vehicle/trailer combination could be affected. Refer to the owner's manual or talk to your dealer or vehicle manufacturer if you have any questions regarding proper inflation practices.

Tires can lose air over time. In fact, tires can lose 1 to 3 PSI per month. This is because molecules of air under pressure, weave their way from the inside of the tire, through the rubber, to the outside. A drop-in tire pressure could cause the tire to become overloaded, leading to excessive heat buildup. If a trailer tire is under-inflated, even for a short period of time, the tire could suffer internal damage.

High speed towing in hot conditions, degrades trailer tires significantly. As heat builds up during driving, the tire's internal structure starts to breakdown, compromising the strength of the tire. It is recommended to drive at moderate speeds.

TIRE SAFETY INFORMATION

Statistics indicate that the average life of a trailer tire is about five years under normal use and maintenance conditions. After three years, replacing the trailer tires with new ones should be considered, even if the tires have adequate tread depth. Some experts claim that after five years, trailer tires are considered worn out and should be replaced, even if they have had minimal or no use. This is such a general statement that it may not apply in all cases. It is best to have your tires inspected by a tire supplier to determine if your tires need to be replaced.

If you are storing your trailer for an extended period, make sure the tires are fully inflated to the maximum rated pressure and that you store them in a cool, dry place, such as a garage. Use tire covers to protect the trailer tires from the harsh effects of the sun.

3.2 STEPS FOR DETERMINING CORRECT LOAD LIMIT-TRAILER

Determining the load limits of a trailer includes more than understanding the load limits of the tires alone. On all trailers there is a Federal Certification / VIN label that is located on the forward half of the left (road) side of the unit. This certification/VIN label will indicate the trailers Gross Vehicle Weight Rating (GVWR). This is the most weight the fully loaded trailer can weigh. It will also provide the Gross Axle Weight Rating (GVWR). This is the most any axle can weigh. If there are multiple axles, the GVWR of each axle will be provided.

If your trailer has a GVWR of 10,000 pounds or less, there is a vehicle placard located in the same location as the certification label described above. This placard provides tire and loading information. In addition, this placard will show a statement regarding maximum cargo capacity. Cargo can be added to the trailer, up to the maximum weight specified on the placard. The combined weight of the cargo is provided as a single number. In any case, remember: the total weight of a fully loaded trailer cannot exceed the stated GVWR.

When loading your cargo, be sure it is distributed evenly to prevent overloading front to back and side to side. Heavy items should be placed low and as close to the axle positions as reasonable. Too many items on one side may overload a tire. The best way to know the actual weight of the vehicle is to weigh it at a public scale. Talk to your dealer to discuss the weighing methods needed to capture the various weights related to the trailer. This would include the weight empty or unloaded, weights per axle, wheel, hitch or king-pin, the total weight.

Excessive loads and / or under inflation cause tire overloading and, as a result, abnormal tire flexing occurs. This situation can generate an excessive amount of heat within the tire. Excessive heat may lead to tire failure. It is the air pressure that enables a tire to support the load, so proper inflation is critical. The proper air pressure may be found on the Certification / VIN label and / or on the Tire Placard. This value should never exceed the maximum cold inflation pressure stamped on the tire.

TIRE SAFETY INFORMATION

3.2.1 Trailers 10,000 Pounds GVWR or Less

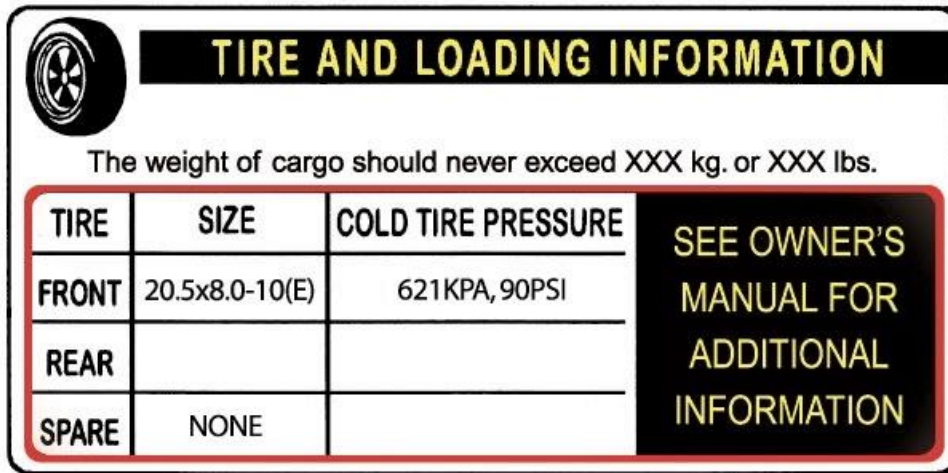

Tire Information Placard - Figure 3-1

Locate the statement, "The weight of cargo should never exceed XXX kg or XXX lbs., on your vehicle's placard. See Figure 3-1.

This figure equals the available amount of cargo and luggage load capacity.

Determine the combined weight of luggage and cargo being loaded on the vehicle. That weight may not safely exceed the available cargo and luggage capacity

The trailer's placard refers to the Tire Information Placard attached adjacent to or near the trailer's VIN (Certification) label at the left front of the trailer.

3.2.2 Trailers Over 10,000 Pounds GVWR

(Note: These trailers are not required to have a tire information placard on the trailer and may not have one installed.)

1. Determine the empty weight of your trailer by weighing the trailer using a public scale or other means.
2. Locate the GVWR (Gross Vehicle Weight Rating) of the trailer on your trailers VIN (Certification) Label.
3. Subtract the empty weight of your trailer from the GVWR stated on the VIN label. That weight is the maximum available cargo capacity of the trailer and may not be safely exceeded.

3.3 STEPS FOR DETERMINING CORRECT LOAD LIMIT-TOW VEHICLE

1. Locate the statement, "The combined weight of occupants and cargo should never exceed XXX lbs." on your vehicles placard.
2. Determine the combined weight of the driver and passengers who will be riding in your vehicle.
3. Subtract the combined weight of the driver and passengers from XXX kilograms or XXX pounds.
4. The resulting figure equals the available amount cargo and luggage capacity.
 - For example, if the "XXX" amount equals 1400 lbs. and there will be five 150 lb. passengers in your vehicle, the amount of available cargo and luggage capacity is 650lbs. (1400-750(5 x 150) =650 lbs.).
5. Determine the combined weight of luggage and cargo being loaded on the vehicle. That weight may not safely exceed the available cargo and luggage capacity calculated in Step #4.

TIRE SAFETY INFORMATION

6. If your vehicle will be towing a trailer, load from your trailer will be transferred to your vehicle. Consult the tow vehicle's manual to determine how this weight transfer reduces the available cargo and luggage capacity of your vehicle.

3.4 GLOSSARY OF TERMINOLOGY

Accessory weight- the combined weight (standard items which may be replaced in excess) of automatic transmission, power steering power brakes, power windows, power seats, radio and heater, to the extent that these items are available as factory-installed equipment (whether installed or not).

Bead- the part of the tire that is made of steel wires, wrapped or reinforced by ply cords and that is shaped to fit the rim.

Bead Separation- this is the breakdown of the bond between components in the bead.

Bias Ply Tire- a Pneumatic tire in which the ply cords that extend to the beads are laid at alternate angles substantially less than 90 degrees to the centerline of the tread.

Carcass- the tire structure, except tread and sidewall rubber which, when inflated, bears the load.

Chunking- the breakaway of pieces of the tread or sidewall.

Cold Inflation Pressure- the pressure in the tire before you drive.

Cord-the strands forming the plies in the tire.

Cord Separation- the parting of cords from adjacent rubber compounds.

Cracking- any parting within the tread, sidewall, or inner liner of the tire extending to cord material.

CT- a pneumatic tire with an inverted flange tire and rim system in which the rim is designed to fit on the underside of the rim in a manner that encloses the rim flanges inside the air cavity of the tire.

Curb Weight- the weight of a motor vehicle with standard equipment including the maximum capacity of fuel, oil and coolant, and, if so equipped, air conditioning and additional weight optional engine.

Extra Load Tire- a tire designed to operate at higher loads and at higher inflation pressures than the corresponding standard tire.

Groove- the space between two adjacent tread ribs.

Cross Axle Weight Rating- the maximum weight that any axle can support, as published on the Certification / VIN label on the front left side of the trailer. Actual weight determined by weighing each axle on a public scale, with the trailer attached to the towing vehicle.

GENERAL SAFETY INFORMATION

Gross Vehicle Weight Rating- the maximum weight of the fully loaded trailer, as published on the Certification / VIN label. Actual weight determined by weighing trailer on a public scale, without being attached to the towing vehicle.

Hitch Weight- the downward force exerted on the hitch ball by the trailer coupler.

Inner-liner- the layer(s) forming the inside surface of the tubeless tire that contains the inflating medium within the tire.

Inner-liner Separation- the parting of the inner-liner from cord material in the carcass.

Intended Outboard Sidewall- the sidewall that contains a white-wall, bears lettering or bears manufacturer, brand, and/or model name molding that is higher or deeper than the same molding on the other sidewall of the tire or the outward facing sidewall of an asymmetrical tire that has a side that must always face outward when mounted on a vehicle.

Light Truck (LT) Tire- a tire designated by its manufacturer as primarily intended for use on lightweight trucks of multipurpose passenger vehicles. May be used on trailers.

Load Rating-the maximum load that a tire is rated to carry for a given inflation pressure.

Maximum Load Rating- the load rating for a tire at the maximum permissible inflation pressure for that tire.

Maximum Permissible Inflation Pressure- the maximum cold inflation pressure to which a tire may be inflated.

Maximum Loaded Vehicle Weight- the sum of curb weight, accessory weight, vehicle capacity weight, and production options weight.

Non-pneumatic rim- a mechanical device which, when a non-pneumatic tire assembly incorporates a wheel, supports the tire, and attaches, either integrally or separable, to the wheel center member and upon which the tire is attached.

Non-pneumatic Spare Tire Assembly- a non-pneumatic tire assembly intended for temporary use in place of one of the pneumatic tires and rims that are fitted to a passenger car in compliance with the requirements of this standard.

Non-pneumatic Tire- a mechanical device which transmits, either directly or through a wheel or wheel center member, the vertical load and tractive forces from the roadway to the vehicle, generates the tractive forces that provide directional control of the vehicle and does not rely on the containment of any gas or fluid for providing those functions.

Non-pneumatic Tire Assembly- a non-pneumatic tire, alone or in combination with a wheel or wheel center member, which can be mounted on a vehicle.

Normal Occupant Weight- this means 68 kilograms (150lbs.) times the number of occupants specified in the second column of Table I of 49 CFR 571.110.

TIRE SAFETY INFORMATION

Occupant Distribution- the distribution of occupants in a vehicle as specified in the third column of Table I for 49 CFR 571.110.

Open Splice- any parting at any junction of tread, sidewall, or inner-liner that extends to cord material.

Outer Diameter- the overall diameter of an inflated new tire.

Overall Width- the linear distance between the exteriors of the sidewalls of an inflated tire, including elevations due to labeling, decorations, or protective bands or ribs.

Pin Weight- the downward force applied to the 5th wheel or gooseneck ball, by the trailer kingpin or gooseneck coupler.

Ply- a layer of rubber-coated parallel cords.

Ply Separation- a parting of rubber compound between adjacent plies.

Pneumatic tire- a mechanical device made of rubber, chemicals, fabric and steel or other materials, that, when mounted on an automotive wheel provides the traction and contains the gas or fluid that sustains the load.

Productions options weight- the combined weight of those installed regular production options weighing over 2.3 kilograms (5lbs) those standard items which they replace in excess, not previously considered in curb weight or accessory weight, including heavy duty brakes, ride levelers, roof rack, heavy duty battery, and special trim.

Radial Ply Tire- a pneumatic tire in which the ply cords that extend to the beads are laid at substantially 90 degrees to the centerline of the tread.

Recommended inflation pressure- this is the inflation pressure provided by the vehicle manufacturer on the Tire Information label and on the Certification/VIN tag.

Reinforced tire- a tire designed to operate at higher loads and at higher inflation pressures than the corresponding standard tire.

Rim- a metal support for a tire or a tire and tube assembly upon which the tire beads are seated.

Rim diameter- this means the nominal diameter of the bead seat.

Rim size designation- this means the rim diameter width.

Rim type designation- this means the industry of manufacturer's designation for a rim by style or code.

Rim width- this means the nominal distance between rim flanges.

Section Width- the linear distance between the exteriors of the sidewalls of an inflated tire, excluding elevations due to labeling, decoration, or protective bands.

TIRE SAFETY INFORMATION

Sidewall- That portion of tire between the tread and bead.

Sidewall separation- the parting of the rubber compound from the cord material in the sidewall.

Special Trailer (ST) tire- the “ST” is an indication the tire is for trailer use only.

Test rim- the rim on which a tire is fitted for testing and may be any rim listed as appropriate for use with that tire.

Tread- the portion of a tire that has contact with the road

Tread rib- a tread section running circumferentially around a tire.

Tread separation- pulling away of the tread from the tire carcass.

Tread-ware indicators (TWI) - the projections within the principal grooves designed to give a visual indication of the degrees of wear of the tread.

Vehicles capacity weight- the rated cargo and luggage load plus 68 kilograms (150 lbs.) times the vehicles designated seating capacity.

Vehicle maximum load on the tire- the load on an individual tire that is determined by distributing to each axle its share of the maximum loaded vehicle weight and dividing by two.

Vehicle normal load on the tire- the load on an individual tire that is determined by distributing to each axle its share of the curb weight, accessory weight, and normal occupant weight (distributed in accordance with Table I of CRF 49 571.110) and dividing by 2.

Weather side- the surface area of the rim not covered by the inflated tire.

Wheel center member- in the case of a non-pneumatic tire assembly not incorporating a wheel, a mechanical device which attaches, either integrally or separable, to the non-pneumatic rim and provides the connection between the non-pneumatic rim and the vehicle: or, in the case of a non-pneumatic tire assembly not incorporating a wheel, a mechanical device which attaches, either integrally or separable, to the non-pneumatic tire and provides the connection between tire and the vehicle.

Wheel-Holding fixture- the fixture used to hold the wheel and tire assembly securely during testing.

3.5 TIRE SAFETY – EVERYTHING RIDES ON IT

The National Traffic Safety Administration (NHTSA) has published a brochure (DOT HS 809 361) that discusses all aspects of Tire Safety, as required by CFR 575.6. This brochure is reproduced in part below. It can be obtained and downloaded from NHTSA, free of charge, from the following web site:

http://www.nhtsa.dot.gov/cars/rules/TireSafety/ridesonit/tires_index.html

Studies of tire safety show that maintaining proper pressure, observing tire and vehicle load limits (not carrying more weight in your vehicle than your tires or vehicles can safely handle), avoiding road hazards, and inspecting tires for cuts, slashes, and other irregularities are the most important things you can do to

TIRE SAFETY INFORMATION

avoid tire failure, such as tread separation or blow out and flat tires. These actions, along with other care and maintenance activities can also:

- Improve vehicle handling
- Help protect you and others from avoidable breakdowns and accidents
- Improve fuel economy
- Increase the life of your tires

This booklet presents a comprehensive over view of tire safety, including information on the following topics:

- Basic tire maintenance
- Uniform tire quality grading system
- Fundamental characteristics of tires
- Tire safety tips

Use this information to make tire safety a regular part of your vehicle maintenance routine. Recognize that the time you spend is minimal compared with the inconvenience and safety consequences of a flat tire or other tire failure.

3.5.1 Basic Tire Maintenance

Properly maintained tires improve the steering, stopping, traction and load-carrying capability of your vehicle. Underinflated tires and overloaded vehicles are major cause of tire failure. Therefore, as mentioned above, to avoid flat tires and other types of tire failure, you should maintain proper tire pressure, observe tire and vehicle load limits, avoid hazards and regularly inspect your tires.

3.5.2. Finding your Vehicles Recommended Tire Pressure and Load Limits

Tire information placards and vehicle certifications labels contain information on tires and load limits. These labels indicate the vehicle manufacturer's information including:

- Recommended tire size
- Recommended tire inflation pressure
- Vehicle capacity weight (VCW- the maximum occupant and cargo weight a vehicle is designed to carry)
- Front and rear gross axle weight ratings (GAWR- the maximum weight the axle systems are designed to carry).

Both placards and certification labels are permanently attached to the trailer near the left front.

3.5.3 Understanding Tire Pressure and Load Limits

Tire inflation pressure is the level of air in the tire that provides it with load-carrying capacity and affects the overall performance of the vehicle. The tire inflation pressure is a number that indicates the amount of air pressure- measured in pounds per square inch (PSI)- a tire requires to be properly inflated. (You will also find this number on the vehicle information placard expressed in kilopascals (kPa), which is the metric measure used internationally.)

Manufacturers of passenger vehicles and light trucks determine this number based on the vehicles design load limit, that is, the greatest amount of weight a vehicle can safely carry, and the vehicles tire size. The proper tire pressure for your vehicle is referred to as the "recommended cold inflation pressure." (As you will read below, it is difficult to obtain the recommended tire pressure if your tires are not cold.) Because tires are designed to be used on more than one type of vehicle, tire manufacturers list the "maximum permissible inflation pressure" on the tire sidewall. This number is the greatest amount of air pressure that should ever be put in the tire under normal driving conditions.

TIRE SAFETY INFORMATION

3.5.4 Checking Tire Pressure

It is important to check your vehicles tire pressure at least once a month for the following reasons:

- Most tires may naturally lost air over time.
- Tires can lose air suddenly if you drive over a pothole or other object or if you strike the curb when parking
- With radial tires, it is usually not possible to determine under inflation by visual inspection.

For convenience, purchase a tire pressure gauge to keep in your vehicle. Gauges can be purchased at tire dealerships, auto supply stores, and other retail outlets. The recommended tire inflation pressure that vehicle manufacturers provide reflects the proper psi when tire is cold. The term cold does not relate to the outside temperature. Rather, a cold tire is one that has not been driven for at least 3 hours. When you drive your tires get warmer, causing the air pressure within them to increase. Therefore, to get an accurate reading, you must measure tire pressure when the tires are cold or compensate for the extra pressure in warm tires.

3.5.5 Steps for Maintaining Proper Tire Pressure

Step 1) Locate the recommended tire pressure on the vehicle's tire information placard, certification label, or in the owner's manual

Step 2) Record the tire pressure of all tires

Step 3) if the tire pressure is too high in any of the tires, slowly release air by gently pressing on the tire valve stem with the edge of your tire gauge until you get the correct pressure.

Step 4) if the tire pressure is too low, note the difference between the measured tire pressure and the correct tire pressure. These "missing" pounds of pressure are what you need to add

Step 5) at a service station, add the missing pounds of air pressure to each tire that is underinflated.

Step 6) check all the tires to make sure they have the same air pressure (except in cases in which the front and rear tires are supposed to have different amounts of pressure).

If you have been driving your vehicle and think that a tire is underinflated, fill it to the recommended cold inflation pressure indicated on your vehicle's tire information placard or certification label. While your tire may be still slightly underinflated due to the extra pounds of pressure in the warm tire, it is safer to drive with air pressure that is slightly lower than the vehicle manufacturer's recommended cold inflation pressure than to drive with a significantly underinflated tire. Since this is a temporary fix, don't forget to recheck and adjust the tires pressure when you can obtain a cold reading.

3.5.6 Tire Size

To maintain tire safety, purchase new tires that are the same size as the vehicles original tires or another size recommended by the manufacturer. Look at the tire information placard, the owner's manual, or the sidewall of the tire you are replacing to find this information. If you have any doubt about the correct size to choose, consult with the tire dealer.

3.5.7 Tire Tread

The tire tread provides the gripping action and traction that prevent your vehicle from slipping or sliding, especially when the road is wet or icy. In general, tires are not safe and should be replaced when the tread is worn down to 2/32 of an inch. Tires have built in tread wear indicators. These indicators are raised sections spaced intermittently in the bottom of the tread grooves. When they

TIRE SAFETY INFORMATION

appear “even” with the outside of the tread, it is time to replace your tires. Another method for checking tread depth is to place a penny in the tread with Lincoln’s head upside down and facing you. If you can see the top of Lincoln’s head, you are ready for new tires.

3.5.8 Tire Balance and Wheel Alignment

To avoid vibration or shaking of the vehicle when a tire rotates, the tire must be properly balanced. This balance is achieved by positioning weights on the wheel to counterbalance heavy spots on the wheel and tire assembly. A wheel alignment adjusts the angles of the wheels so that they are positioned correctly relative to the vehicle’s frame. This adjustment maximizes the life of your tires. These adjustments require special equipment and should be performed by a qualified technician.

3.5.9 Tire Repair

The proper repair of a punctured tire requires a plug for the whole and a patch for the area inside the tire that surrounds the puncture hole. Punctures through the tread can be repaired if they are not too large, but punctures to the side wall should not be repaired. Tires must be removed from the rim to be properly inspected before being plugged and patched.

3.5.10 Tire Fundamentals

Federal law requires tire manufacturers to place standardized information on the sidewall of all tires. This information identifies and describes the fundamental characteristics of the tire as well as provide a tire identification number for safety standard certification and in case of a recall.

3.5.10.1 Information on Passenger Vehicle Tires

Please refer to the diagram below

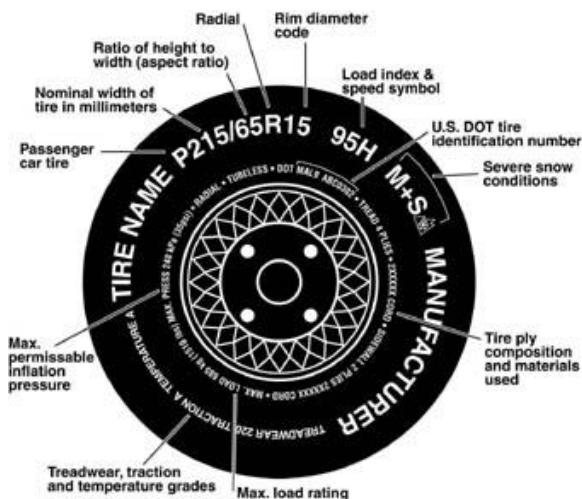

P - The “P” indicates the tire is for passenger vehicles.

Next number - This three-digit number gives the width in millimeters of the tire from sidewall edge to sidewall edge. In general, the larger the number, the wider the tire.

Next number - This two-digit number, known as the aspect ratio, gives the tire’s ratio of height to width. Numbers of 70 or lower indicate a short sidewall for improved steering response and better overall handling on dry pavement.

GENERAL SAFETY INFORMATION

R - The “R” stands for radial. Radial ply construction of tires has been the industry standard for the past 20 years.

Next Number - This two-digit number is the wheel or rim diameter in inches. If you change your wheel size, you will have to purchase new tires to match the new diameter.

Next Number - These two – or three-digit number is the tire’s load index. It is a measurement of how much weight each tire can support. You may find this information in your owner’s manual. If not, contact a local tire dealer. Note: You may not find this information on all tires because it is not required by law.

M+S - The “M+S” or “M/S” indicates that the tire has some mud and snow capability. Most radial tires have these markings; hence, they have some mud and snow capability.

Speed Rating - The Speed rating denotes the speed at which a tire is designed to be driven for extended periods of time. The ratings range from 99 miles per hour (mph) to 186 mph. These ratings are listed below. Note: you may not find this information on all tires because it is not required by law.

Letter Rating	Speed Rating
Q	99 mph
R	106 mph
S	112 mph
T	118 mph
U	124 mph
H	130 mph
V	149 mph
W	168* mph
Y	186* mph

*For tires with a maximum speed capability over 149 mph, tire manufacturers sometimes use the letters ZR. For those with a maximum speed capability over 186 mph, tire manufacturers always use the letters ZR.

U.S. DOT Tire Identification Number - This begins with the letters “DOT” and indicates that the tire meets all federal standards. The next two numbers or letters are the plant code where it was manufactured, and the last four numbers represent the week and year the tire was built. For example, the numbers 2683 means the twenty sixth week of 1983. The other numbers are marketing codes used at the manufacturer’s discretion. This information is used to contact consumers if a tire defect requires recall.

Tire Ply Composition and Materials Used - The number of plies indicates the number of layers or rubber-coated fabric in the tire. In general, the greater the number of plies, the more weight a tire can support. Tire manufacturers also must indicate the materials in the tire, which include steel, nylon, polyester and others.

TIRE SAFETY INFORMATION

*For tires with a maximum speed capability over 149 mph, tire manufacturers sometimes use the letters ZR. For those with a maximum speed capability over 186 mph, tire manufacturers always use the letters ZR.

U.S. DOT Tire Identification Number - This begins with the letters "DOT" and indicates that the tire meets all federal standards. The next two numbers or letters are the plant code where it was manufactured, and the last four numbers represent the week and year the tire was built. For example, the numbers 2683 means the twenty sixth week of 1983. The other numbers are marketing codes used at the manufacturer's discretion. This information is used to contact consumers if a tire defect requires recall.

Tire Ply Composition and Materials Used - The number of plies indicates the number of layers or rubber-coated fabric in the tire. In general, the greater the number of plies, the more weight a tire can support. Tire manufacturers also must indicate the materials in the tire, which include steel, nylon, polyester and others.

Maximum Load Rating - This number indicates the maximum load in kilograms and pounds that can be carried by the tire.

Maximum Permissible Inflation Pressure - This number is the greatest amount of air pressure that should ever be put in the tire under normal driving conditions.

3.5.10.2 UTQGS Information

Treadwear Number - This number indicates the tire's wear rate. The higher the treadwear number is, the longer it should take for the tread to wear down. For example, a tire graded 400 should last twice as long, as a tire graded 200. **Traction Letter** This letter indicates a tire's ability to stop on wet pavement. A higher graded tire should allow you to stop your car on wet roads in a shorter distance than a tire with a lower grade. Traction is graded from highest to lowest as "AA", "A", "B", and "C".

Temperature Letter - This letter indicates a tire's resistance to heat. The temperature grade is for a tire that is inflated properly and not overloaded. Excessive speed, underinflation or excessive loading, either separately or in combination, can cause heat build-up and possible tire failure. From highest to lowest, a tire's resistance to heat is graded as "A", "B", or "C".

3.5.10.3 Additional Information on Light Truck Tires

Please refer to the following diagram.

COUPLING TO THE TOW VEHICLE

Follow all the safety precautions and instructions in this manual to ensure safety of persons, cargo, and satisfactory life of the trailer.

4.1 USE AN ADEQUATE TOW VEHICLE AND HITCH

If the vehicle or hitch is not properly selected and matched to the Gross Vehicle Weight Rating (GVWR) of your trailer, you can cause an accident that could lead to death or serious injury. If you already have a tow vehicle, know your vehicle tow rating and make certain the trailer's rated capacity is less than or equal to the tow vehicle's rated towing capacity.

DANGER

DANGER- Use of a hitch with a load rating less than the load rating of the trailer can result in loss of control and may lead to death or serious injury.

Use of a tow vehicle with a towing capacity less than the load rating of the trailer can result in loss of control and may lead to death or serious injury.

Be sure your hitch and tow vehicle are rated for the Gross Vehicle Weight Rating of your trailer.

4.1.1 Trailer Information

The Certification / Vehicle Identification Number (VIN) tag is located on the front left corner of your trailer. The trailer Certification / VIN tag contains the following critical safety information for the use of your trailer:

MANUFACTURER: Doolittle Trailer Mfg., Inc.

DATE OF MANUFACTURE: Month and year the trailer was manufactured.

GVWR: The Gross Vehicle Weight Rating is the maximum allowable gross weight of the trailer and its contents. The gross weight of the trailer includes the weight of the trailer and all the items within it (such as cargo, water, food and other supplies). GVWR is sometimes referred to as GTW (Gross Trailer Weight), or MGTW (Maximum Gross Trailer Weight). GVWR, GTW and MGTW are all the same rating.

GVWR: The Gross Axle Weight Rating is the maximum gross weight that an axle can support. It is the lowest of axle, wheel, or tire rating. Sometimes the tire or wheel rating is lower than the axle manufacturers rating and will then determine GVWR. The sum of the GVWR for all trailer axles may be less than the GVWR for the trailer, because some of the trailer load is carried by the tow vehicle, rather than by the trailer axle(s). The total weight of the cargo and trailer must not exceed the GVWR, and the load on an axle must not exceed its GVWR.

TIRE SIZE: The tire size recommended for your trailer and load range.

PSIC: The "pounds per square inch- cold" is the tire pressure (Kilopascals / Pounds per Square Inch) measured when Cold.

COUPLING TO THE TOW VEHICLE

VIN: The Vehicle Identification Number.

VEHICLE TYPE: Generally, the word “trailer” is used. However, after this you may put a Model #, or additional descriptor.

CERTIFICATION STATEMENT: “This trailer meets all the Federal Motor Vehicle Safety Standards in effect on the date of manufacture shown above”.

4.1.2 Tow Vehicle

When equipping a new vehicle or an older vehicle to tow your trailer, ask the vehicle dealer for advice on how to outfit the towing vehicle. Discuss the following information and equipment with the vehicle dealer.

Overall Carrying and Towing Capacity of Vehicle: Vehicle manufacturers will provide you with the maximum towing capacities of their various models, as well as the GCWR. No amount of reinforcement will give a 100 horsepower, 2,500 lb. truck the towing capacity that a 300 horsepower, 5,000 lb. truck has.

Towing Hitch: The towing hitch attached to your tow vehicle must have a capacity equal to or greater than the load rating of the trailer you intend to tow. The hitch capacity must also be matched to the tow vehicle capacity.

Suspension System: A tow vehicle equipped with a factory installed “Towing Package” likely comes equipped with heavy duty springs, heavy duty tires and other suspension components which can serve the size and weight of the trailer that the vehicle is rated to tow. However, the addition of additional equipment may further improve the tow vehicle performance. These may include adjustable air shocks, helper springs, etc.

Brake Controller: The brake controller is part of the tow vehicle and is essential in the operation of the electric brakes on the trailer. If your trailer has electric brakes it requires a brake controller be installed at the driver’s position. The brake controller is not the same as the safety breakaway brake system that is installed on the trailer.

Side View Mirrors: The size of the trailer that is being towed and your state law regulations determine the size of the mirrors. However, some states prohibit extended mirrors on a tow vehicle, except while a trailer is towed. In this situation, detachable extended mirrors are necessary. Check with your dealer or the appropriate state agency for mirror requirements.

Heavy Duty Flasher: A heavy duty Flasher is an electrical component that may be required when your trailer turn signal lights are attached to the tow vehicle flasher circuit.

Electrical Connector: An Electrical Connector connects the light and brake systems on the trailer to the light and brake controls on the towing vehicle.

Heavy Duty Engine Oil Cooling System: The tow vehicle engine works harder when a trailer is being towed. Depending on the size of the trailer, you may need to install a separate engine oil cooler. Inadequate cooling may result in sudden engine failure. Ask the tow vehicle dealer if it is necessary to install a heavy duty, cooling system.

COUPLING TO THE TOW VEHICLE

Automatic Transmission Oil Cooler: The automatic transmission of a towing vehicle handles more power when a trailer is being towed. Inadequate cooling will shorten transmission life and may result in sudden transmission failure. Ask the tow vehicle dealer if it is necessary to install a separate oil cooler for the automatic transmission.

Fire Extinguisher: It is sensible to have a fire extinguisher in the tow vehicle.

Emergency Flares and Emergency Triangle Reflectors: It is wise to carry these warning devices even if you are not towing a trailer. It is particularly important to have these when towing a trailer because the hazard flashers of your towing vehicle will not operate for as long a period when the battery is running both the trailer lights and tow vehicle lights.

4.2 COUPLING AND UNCOUPLING THE TRAILER

A secure coupling (or fastening) of the trailer to the tow vehicle is essential. A loss of coupling may result in death or serious injury. Therefore, you must understand and follow all the instructions for coupling.

The following parts are involved in making a secure coupling between the trailer and tow vehicle:

Coupling: That part of the trailer connecting mechanism by which the connection is made to the trailer hitch. This does not include any structural member, extension of the trailer frame, or brake controller.

Hitch: That part of the connecting mechanism including the ball support platform and ball and those components that extend and are attached to the towing vehicle, including bumpers intended to serve as hitches.

Safety chains: Chains permanently attached to the trailer such that if the coupler connection comes loose, the safety chains can keep the trailer attached to the tow vehicle. With properly rigged safety chains, it is possible to keep the tongue of the trailer from digging into the road pavement, even if the coupler-to-hitch connection comes apart.

Trailer lighting (and braking) connector: A device that connects electrical power from the tow vehicle to the trailer. Electricity is used to turn on brake lights, running lights, and turn signals as required. In addition, if your trailer has a separate braking system, the electrical connector will also supply power to the trailer brakes from the tow vehicle.

Breakaway switch: If the trailer becomes de-coupled from the towing vehicle, the breakaway switch lanyard, attached independently to the tow vehicle hitch, will pull a pin in the emergency electrical breakaway switch on the trailer. The breakaway switch is activated by a separate battery supply in the trailer such as to energize the trailer brakes independently of the towing vehicle. It is important to check the state of charge of the emergency breakaway battery before each trip. Simply pull the pin out of the switch by hand and then try to pull the trailer. If you feel a significant drag force the brakes are activated. Be sure to re-insert the pin in the breakaway switch. Also, be sure to allow enough slack in the breakaway brake lanyard such that the switch will only activate (pin pulls out) if the coupler connection comes loose.

Jack: A device on the trailer that is used to raise and lower the trailer tongue. On larger trailers the jack is sometimes called the “landing gear.”

COUPLING TO THE TOW VEHICLE

WARNING

WARNING- An improperly coupled trailer can result in death or serious injury.

Do not move the trailer until:

- The coupler is secured and locked to hitch;
- The safety chains are secured to the tow vehicle;
- The trailer jack(s) are fully retracted.

Do not tow the trailer on the road until:

- Tires and wheels are checked;
- The trailer brakes are checked;
- The breakaway switch is connected to the tow vehicle;
- The load is secured to the trailer; and
- The trailer lights are connected and checked.

4.2.1 Various Coupler Designs

Trailers are produced with a variety of coupler devices. One of the sections below will pertain to your trailer.

- Bumper pull ball coupler or ring coupler
- Gooseneck ball coupler
- Gooseneck fifth wheel or king pin coupler If the coupler on your trailer does not resemble one of the couplers shown in the figures, see the separate coupler instructions

If you do not have separate coupler instructions, call Doolittle Trailer Mfg., Inc. at 800-654-4948 for a free copy.

4.3 BUMPER PULL TRAILERS

4.3.1 Trailer with Ball Hitch Coupler

A ball hitch coupler connects to a ball that is located on or under the rear bumper of tow vehicle. This system of coupling a trailer to a tow vehicle is sometimes referred to as “bumper pull.”

We have utilized a ball hitch coupler that is suitable for the size and weight of the trailer. The load rating of the coupler and the necessary ball size are listed on the trailer tongue. You must provide a hitch and ball for your tow vehicle, where the load rating of the hitch and ball is equal to or greater than that of your trailer. Also, the ball size must be the same as the coupler size. If the hitch ball is too small, too large, is underrated, is loose or is worn, the trailer can come loose from the tow vehicle, and may cause death or serious injury.

THE TOW VEHICLE, HITCH AND BALL MUST HAVE A RATED TOWING CAPACITY EQUAL TO OR GREATER THAN THE TRAILER Gross Vehicle Weight Rating (GVWR).

IT IS ESSENTIAL THAT THE HITCH BALL BE OF THE SAME SIZE AS THE COUPLER.

THE BALL SIZE AND LOAD RATING (CAPACITY) ARE MARKED ON THE BALL.

THE HITCH CAPACITY IS MARKED ON THE HITCH.

COUPLING TO THE TOW VEHICLE

4.3.1.1 Before Coupling the Trailer to The Tow Vehicle

Be sure the size and rating of hitch ball match the size and rating of the coupler. Hitch balls and couplers are marked with their size and rating.

WARNING

WARNING- Coupler-to-hitch mismatch can result in uncoupling, leading to death or serious injury. Be sure the **LOAD RATING** of the hitch ball is equal or greater than the load rating of the coupler. Be sure the **SIZE** of the hitch ball matches the size of the coupler.

- Wipe the hitch ball clean and inspect it visually and by feel for flat spots, cracks and pits

WARNING

WARNING- A worn, cracked or corroded hitch ball can fail while towing, and may result in death or serious injury. Before coupling trailer, inspect the hitch ball for wear, corrosion and cracks. Replace worn or damaged hitch ball.

- Rock the ball to make sure it is tight to the hitch, and visually check that the hitch ball nut is solid against the lock washer and hitch frame
- Wipe the inside and outside of the coupler clean and inspect it visually for cracks and deformations; feel the inside of the coupler for worn spots and pits
- Be sure the coupler is tight to the tongue of the trailer. All coupler fasteners must be visibly solid against the trailer frame

WARNING

WARNING- A loose hitch ball nut can result in uncoupling, leading to death or serious injury. Make sure the hitch ball is tight to the hitch before coupling the trailer.

- Raise the bottom surface of the coupler to be above the top of the hitch ball

4.3.1.2 Prepare the Coupler and Hitch

- Lubricate the hitch ball and the inside of the coupler with a thin layer of automotive bearing grease
- Remove the safety latch pin and open the coupler locking mechanism
- In the open position, the coupler can drop fully onto the hitch ball
- See the coupler instructions for details of placing the coupler in the “open” position
- Slowly back up the tow vehicle so that the hitch ball is near or aligned under the coupler

COUPLING TO THE TOW VEHICLE

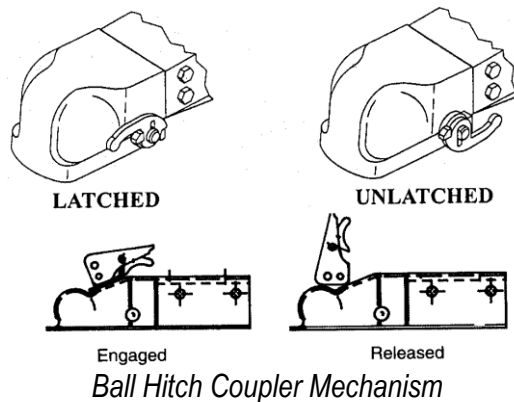

4.3.1.3 Couple the Trailer to The Tow Vehicle

- Lower the trailer tongue until the coupler fully engages the hitch ball. If the coupler does not line up with the hitch ball, adjust the position of the tow vehicle
- Engage the coupler locking mechanism. In the engaged position, the locking mechanism securely holds the coupler to the hitch ball
- Insert the safety lock pin through the hole in the locking mechanism
- Be sure the coupler is all the way on the hitch ball and the locking mechanism is engaged. A properly engaged locking mechanism will allow the coupler to raise the rear of the tow vehicle. Using the trailer jack, test to see that you can raise the rear of the tow vehicle by 1

NOTICE

NOTICE- The tongue jack can be damaged by overloading. Do not use the tongue jack to raise the tow vehicle more than 1 inch.

If the coupler cannot be secured to the hitch ball, do not tow the trailer. Call Doolittle Trailer Mfg., Inc. at 800-654-4948 or your dealer for assistance.

- Lower the trailer so that its entire tongue weight is held by the hitch and continue retracting the jack to its fully retracted position
- Fully retract jack drop leg and insert pin
- Go to Section 4.3.3 “Rig the Safety Chains – Bumper Pull Trailer” to continue connecting trailer to tow vehicle

4.3.2 Trailer with Ring and Pintle Coupler

A ring connects to the pintle that is located on or under the rear bumper of tow vehicle. This system of coupling a trailer to a tow vehicle is sometimes referred to as “bumper pull.”

COUPLING TO THE TOW VEHICLE

We have utilized a ring that is suitable for the size and weight of the trailer. The load rating of the ring and the necessary pintle size are listed on the trailer tongue. You must provide a pintle for your tow vehicle, where the load rating of the hitch and pintle is equal to or greater than that of your trailer. Also, the pintle size must be the same as the ring size. If the pintle is too small, too large, is underrated, is loose or is worn, the trailer can come loose from the tow vehicle, and may cause death or serious injury.

THE TOW VEHICLE, HITCH AND PINTLE MUST HAVE A RATED TOWING CAPACITY EQUAL TO OR GREATER THAN THE TRAILER Gross Vehicle Weight Rating (GVWR). IT IS ESSENTIAL THAT THE PINTLE BE OF THE SAME SIZE AS THE COUPLER.

- The pintle size and load rating (capacity) are marked on the pintle; ring capacity is marked on the ring.

4.3.2.1 Before Coupling the Trailer to The Tow Vehicle

Be sure the size and rating of pintle match the size and rating of the ring. Hitch ring and pintles are marked with their size and rating.

WARNING

WARNING- Coupler-to-hitch mismatch can result in uncoupling, leading to death or serious injury. Be sure the LOAD RATING of the pintle is equal or greater than the load rating of the ring. Be sure the SIZE of the pintle matches the size of the ring.

- Wipe the pintle clean and inspect it visually and by feel for flat spots, cracks and pits.

WARNING

WARNING- A worn, cracked or corroded pintle can fail while towing, and may result in death or serious injury. Before coupling trailer, inspect the pintle for wear, corrosion and cracks. Replace worn or damaged pintle.

- Rock the pintle to make sure it is tight to the hitch, and visually check that the pintle fasteners are solid against the hitch frame
- Wipe the inside and outside of the ring clean and inspect it visually for cracks and deformations; feel the inside of the ring for worn spots and pits
- Be sure the ring is tight to the tongue of the trailer. All ring fasteners must be visibly solid against the trailer frame
- Raise the bottom surface of the ring to be above the top of the open pintle

WARNING

COUPLING TO THE TOW VEHICLE

WARNING- A loose pintle can result in uncoupling, leading to death or serious injury. Make sure the pintle is tight to the hitch before coupling the trailer.

4.3.2.2 Prepare the Ring and Pintle

- Lubricate the inside of the pintle with a thin layer of automotive bearing grease
- Remove the safety latch pin and open the pintle locking mechanism
- In the open position, the ring can drop fully onto the pintle
- See the coupler instructions for details of placing the pintle in the “open” position
- Slowly back up the tow vehicle so that the pintle is near or aligned under the ring

4.3.2.3 Couple the Trailer to The Tow Vehicle

- Lower the trailer tongue until the ring fully engages the pintle. If the ring does not line up with the pintle, adjust the position of the tow vehicle
- Engage the pintle locking mechanism. In the engaged position, the locking mechanism securely holds the ring to the pintle
- Insert the safety lock pin through the hole in the locking mechanism
- Be sure the ring is all the way on the pintle and the locking mechanism is engaged. A properly engaged locking mechanism will allow the pintle to raise the rear of the tow vehicle. Using the trailer jack, test to see that you can raise the rear of the tow vehicle by 1 inch, after the coupler is locked to the hitch

NOTICE

NOTICE- The tongue jack can be damaged by overloading. Do not use the tongue jack to raise the tow vehicle more than 1 inch.

If the coupler cannot be secured to the hitch ball do not tow the trailer. Call Doolittle Trailer Mfg., Inc. at 800-654-4948 or your dealer for assistance.

- Lower the trailer so that its entire tongue weight is held by the hitch and continue retracting the jack to its fully retraced position
- Fully retract jack drop leg and insert pin
- Go to Section 4.3.3 “Rig the Safety Chains – Bumper Pull Trailer” to continue connecting trailer to tow vehicle

4.3.3 Rig the Safety Chains – Bumper Pull Trailers

COUPLING TO THE TOW VEHICLE

- Visually inspect the safety chains and hooks for wear or damage. Replace worn or damaged safety chains and hooks before towing
- Rig the safety chains so that they:
- Crisscross underneath the coupler so if the trailer uncouples, the safety chains can hold the tongue up above the road.
- Loop around a frame member of the tow vehicle or to holes provided in the hitch system (but, do not attach them to an interchangeable part of the hitch assembly)
- Attach hooks up from underneath the hole (do not just drop into hole); and
- Provide enough slack to permit tight turns, but not be close to the road surface to drag



WARNING

WARNING- Incorrect rigging of the safety chains can result in loss of control of the trailer and tow vehicle, leading to death or serious injury, if the trailer uncouples from the tow vehicle.

Chains must:

- Fasten to frame of tow vehicle, not to hitch or ball
- Cross underneath hitch and coupler with minimum slack to permit turning and to hold tongue up, if the trailer comes loose

4.3.4 Connect the Electrical Cable – Bumper Pull Trailers

Connect the trailer lights to the tow vehicle's electrical system using the 7-pin or 4-way connector.

- Check all lights for proper operation. Repair if needed
- Check electric brakes for proper operation using brake controller mounted in the cab

If your trailer has electric brakes, your tow vehicle will have an electric brake controller that sends power to the trailer brakes. Before towing the trailer on the road, you must operate the brake controller while trying to pull the trailer can confirm that the electric brakes operate. While towing the trailer at less than 5 m.p.h., manually operate the electric brake controller in the tow vehicle cab. You should feel the operation of the trailer brakes.

4.3.5 Attach and Test Electric Breakaway Brake System

If the coupler or hitch fails, a properly connected and working breakaway brake system will apply electric brakes on the trailer. The safety chains will keep the tow vehicle attached and as the brakes are applied at the trailer's axles, the trailer/tow vehicle combination will come to a controlled stop.

The breakaway brake system includes a battery, a switch with a pull pin, and a lanyard. Read and follow the instructions here as well as the instructions that have been prepared by the breakaway brake manufacturer. If you do not have these instructions, call Doolittle Trailer Mfg., Inc. at 800-654-4948 for a free copy.

The breakaway brake system is not fitted with a "charging" capability that draws power from the tow vehicle. You must periodically charge the battery to keep the breakaway brake system in working order.

COUPLING TO THE TOW VEHICLE

Connect the pull pin lanyard to the tow vehicle so that the pull pin will be pulled out before all the slack in the safety chains is taken up (see Breakaway Brake System figure). Do not connect the pull pin cable to a safety chain or to the hitch ball or hitch ball assembly. This would keep the breakaway brake system from operating when it is needed.

- To test the break-away brake battery, remove the pull pin from the switch and attempt to pull the trailer forward. You should feel the trailer resisting being towed, but the wheels will not necessarily be locked. If the brakes do not function, do not tow the trailer until brakes, or battery, are repaired.
- Immediately replace the pull pin. The breakaway brake system battery discharges rapidly when the pull pin is removed.
- Do not tow the trailer with the breakaway brake system ON because the brakes will overheat which can result in permanent brake failure.

WARNING

WARNING- Failure to replace the pull pin will prevent brakes from working, leading to loss of control, serious injury or death.

If you do not use your trailer for three or more months, or during winter months:

- Store the battery indoors
- Charge the battery every three months

Replace the breakaway brake battery according to the intervals specified by battery manufacturer.

Connect the trailer lights to the tow vehicle's electrical system using the electrical connectors.

Check all lights for proper operation.

Clearance and Running Lights (Turn on tow vehicle headlights).

Brake Lights (Step on tow vehicle brake pedal).

Turn Signals (Operate tow vehicle directional signal lever).

Check electric brakes for proper operation using brake controller mounted in the cab.

If your trailer has electric brakes, your tow vehicle will have an electric brake controller that sends power to the trailer brakes. Before towing the trailer on the road, you must operate the brake controller while trying to pull the trailer can confirm that the electric brakes operate. While towing the trailer at less than 5 m.p.h., manually operate the electric brake controller in the tow vehicle cab. You should feel the operation of the trailer brakes.

4.3.6 Uncoupling the Bumper Pull Trailer

Follow these steps to uncouple your ball hitch trailer from the tow vehicle:

- Block trailer tires to prevent the trailer from rolling, before jacking the trailer up
- Disconnect the electrical connector
- Disconnect the breakaway brake switch lanyard

COUPLING TO THE TOW VEHICLE

- Disconnect the safety chains from the tow vehicle
- Unlock the coupler and open it
- Before extending jack, make certain the ground surface below the jack pad will support the tongue load
- Rotate the jack handle (or crank) clockwise. This will slowly extend the jack and transfer the weight of the trailer tongue to the jack

4.4 TRAILER WITH GOOSENECK COUPLER

A gooseneck coupler on the trailer connects to a gooseneck ball that you must have installed in the bed of the tow vehicle. This system of coupling a trailer to a tow vehicle permits the tow vehicle to turn to sharper angles than are permitted by a bumper hitch system. A gooseneck coupler consists of a tube in an inverted “U” shape and a gooseneck ball receiver.

We have installed a Gooseneck ball receiver that is suitable for the size and weight of the trailer. The load rating of the coupler and the necessary ball size are listed on the gooseneck.

You must provide a gooseneck ball and support structure that is marked with a rating that meets or exceeds the GVWR of your trailer and matches the size of the gooseneck ball receiver. If the gooseneck ball is too small, is underrated, is loose or is worn, the trailer can come loose from the tow vehicle, and may lead to death or serious injury.

THE TOW VEHICLE, SUPPORT STRUCTURE AND GOOSENECK BALL MUST HAVE A RATED TOWING CAPACITY EQUAL TO OR GREATER THAN THE TRAILER GROSS VEHICLE WEIGHT RATING (GVWR). IT IS ESSENTIAL THAT THE GOOSENECK BALL BE OF THE SAME SIZE AS THE GOOSENECK BALL RECEIVER.

The ball size and load rating (capacity) are marked on the ball; hitch capacity is marked on the hitch.

The height of the ball receiver on the trailer must be adjusted to match the height of the gooseneck ball on your tow vehicle, so that:

- There is clearance between the bottom of the trailer and the sides of the tow vehicle bed
- The trailer is level and allows equal weight distribution on tandem or triple axles

The “Gooseneck Ball Receiver and Height Adjustment” figure shows the gooseneck height adjustment. The gooseneck height adjustment bolts, which have a “cup” that makes a gripping impression into the gooseneck tube, must be tight so that the trailer does not drop to a lower position. Do not over-tighten because the tube can be deformed. After tightening the bolts, tighten the jam nuts on the bolts.

*Some couplers may use a hitch pin with clip instead of a bolt. Be sure to insert retaining clip into pin before use.

*Some couplers are equipped with a set screw(s). This screw(s) must be tightened once the height is determined and the height adjustment bolt/pin is installed.

COUPLING TO THE TOW VEHICLE

WARNING

WARNING- Failure to latch coupler, hook safety chains, and tighten setscrew(s) could cause serious injury, damage or death.

WARNING

WARNING- Improper gooseneck height adjustment can result in overloaded tires, blowout and loss of control, leading to death or serious injury.

Adjust the gooseneck receiver so that the loaded trailer is level.

A trailer having a gooseneck hitch will have one or two drop leg jacks for raising and lowering the gooseneck ball receiver. Because several drop leg jack mechanisms are available, the general instructions below may vary slightly from the jack manufacturer's instructions.

4.4.1 Before Attempting to Tow the Trailer

- Be sure the size and rating of the gooseneck ball match the size and rating of the receiver
- Gooseneck balls and receivers are marked with their size and ratings
- Wipe the gooseneck ball clean and inspect it visually and by feel for flat spots, cracks and pits

WARNING

WARNING- A worn, cracked or corroded gooseneck ball can fail while towing, and may result in death or serious injury.

Before coupling the trailer, inspect the gooseneck ball for wear, corrosion and cracks; and replace worn or damaged gooseneck ball.

Rock the ball to make sure it is tight to the ball support, and visually check that the gooseneck ball nut is solid against the lock washer and ball support frame

WARNING

WARNING- A loose gooseneck ball can result in uncoupling, leading to death or serious injury. Be sure the gooseneck ball nut is tight before coupling the trailer.

COUPLING TO THE TOW VEHICLE

Wipe the inside and outside of the receiver clean and inspect it visually for cracks; and feel the inside of the receiver for worn spots and pits. If any of these conditions exist, have the receiver replaced before coupling the trailer

Lubricate the inside of the gooseneck ball receiver with automotive bearing grease. Be sure the receiver is tight to the trailer. All receiver fasteners must be visibly solid against the trailer frame

Release the jack handle or crank from its holder (see “Drop Leg Jack” figure)

Make certain the ground beneath the jack foot is firm enough to support the tongue weight

Rotate the handle/crank clockwise to raise the bottom surface of the gooseneck to be above the top of the gooseneck ball

4.4.2 Prepare the Ball Receiver and Gooseneck Ball

Release the lock plate on the gooseneck ball receiver. With the spring-loaded lock plate locking pin in the OPEN position, rotate the lock plate to a position that allows the gooseneck ball to enter the receiver (see “Gooseneck Ball Receiver and Height Adjustment” figure)

Slowly back up the tow vehicle so that the gooseneck ball is aligned under the gooseneck ball receiver

WARNING

WARNING- If the trailer drops during coupling, death or serious injury may result. There must be no one under the trailer or coupler before or during the coupling operation.

4.4.3 Couple the Trailer to the Tow Vehicle

Rotate the jack handle counter-clockwise. This will retract the jack causing the gooseneck ball receiver to drop, down so it can fully engage the gooseneck ball and transfer the weight of the trailer tongue to the towing vehicle hitch. If the receiver does not line up with the ball, raise the receiver again and adjust the position of the tow vehicle. Then lower the receiver over the ball. When the drop leg base is no longer resting on the ground, the towing vehicle hitch is holding all the weight of the trailer tongue.

Close the lock plate on the gooseneck ball receiver.

Move the spring-loaded lock plate locking pin to the CLOSED position.

Be sure the locking pin is holding the lock plate. Be sure the receiver is all the way on the gooseneck ball and the lock plate is engaged. A properly engaged locking mechanism will allow the coupler to raise the rear of the tow vehicle. Using the trailer jack, test to see that you can raise the rear of the tow vehicle by 1 inch.

COUPLING TO THE TOW VEHICLE

WARNING

WARNING- Failure to latch coupler, hook safety chains, and tighten setscrew(s) could cause serious injury, damage, or death.

NOTICE

NOTICE- Overloading can damage the drop leg jack. Do not use the drop leg jack to raise the tow vehicle more than 1 inch.

If the gooseneck ball cannot be secured to the receiver, do not tow the trailer. Call Doolittle Trailer Mfg., Inc. at 800-654-4948 or your dealer for assistance.

After testing to see that the receiver is properly secured and locked to the ball, retract the jack to its fully retracted position.

Return the drop legs to their upper positions. The drop legs are held in place with a plunger pin. Rotating the plunger pin while pulling it outward will cause it to come out of engagement with the drop leg.

4.4.4 Rig the Safety Chains

Visually inspect the safety chains and hooks for wear or damage. Replace worn or damaged safety chains and hooks before towing.

Rig the safety chains so that they attach to the “safety chain receivers” in the bed of the truck. If you are not certain of the hitch provisions for receiving safety chains, contact the hitch manufacturer or installer. **DO NOT** attach the safety chains to the gooseneck ball or its support; and

Rig the safety chains so they have sufficient slack to permit turning, but not too much slack – the safety chains must keep the gooseneck on the tow vehicle bed if the trailer uncouples.

WARNING

WARNING- Improper rigging of the safety chains can result in loss of control of the trailer and tow vehicle, leading to death or serious injury, if the trailer uncouples from the tow vehicle.

- Fasten chains to safety chain receivers on the hitch, not to ball.
- Have sufficient slack to permit turning and to keep gooseneck on bed of tow vehicle, if the trailer comes loose.

4.4.5 Connect the Electrical Cables

Connect the trailer lights to the tow vehicle's electrical system using the electrical connectors.

COUPLING TO THE TOW VEHICLE

Check all lights for proper operation:

- Clearance and Running Lights (Turn on tow vehicle headlights).
- Brake Lights (Step on tow vehicle brake pedal).
- Turn Signals (Operate tow vehicle directional signal lever).

Check electric brakes for proper operation

If your trailer has electric brakes, your tow vehicle should have an electric brake controller that sends power to the trailer brakes. Before towing the trailer on the road, you must operate the brake controller while trying to pull the trailer to confirm that the electric brakes operate. While towing the trailer at less than 5 m.p.h., manually operate the electric brake controller in the tow vehicle cab. You should feel the operation of the trailer brakes.

4.4.6 Attach and Test the Breakaway Brake System

If the coupler or hitch fails, a properly connected and working breakaway brake system will apply electric brakes on the trailer. The safety chains will keep the tow vehicle attached and as the brakes are applied at the trailer's axles, the trailer/tow vehicle combination will come to a controlled stop.

The breakaway brake system includes a battery, a switch with a pull pin, and a breakaway brake controller. Read and follow the instructions here as well as the instructions that have been prepared by the breakaway brake controller manufacturer. If you do not have these instructions, call Doolittle Trailer Mfg., Inc at 800-654-4948 for a free copy.

The breakaway brake system is not fitted with a charging facility that draws power from the tow vehicle. You must periodically charge the battery on the trailer to keep the breakaway brake system in working order.

Visually inspect the breakaway brake system for broken parts.

Connect the pull pin cable to the tow vehicle so that the pull pin will be pulled out before all the slack in the safety chains is taken up (see "Safety Chains" figure). Do **not** connect the pull pin cable to a safety chain or a safety chain receiver or to the gooseneck ball or its support. This would keep the breakaway brake system from operating when it is needed. Contact the hitch manufacturer or installer if you are not certain of the hitch provisions for breakaway brake connection

To check the break-away brake battery pull out the pull pin from the switch and attempt to pull the trailer forward. You should feel the trailer resisting being towed, but the wheels will not necessarily lock up.

Immediately replace the pull pin. The breakaway brake system battery discharges rapidly when the pull pin is removed.

Do **not** tow the trailer with the breakaway brake system ON because the brakes will overheat which can result in permanent brake failure.

WARNING

WARNING- Failure to replace the pull pin will prevent brakes from working, leading to loss of control, serious injury or death.

If you do not use your trailer for three or more months, or during winter months:

- Store the battery indoors and charge the battery every three months.

Replace the breakaway brake battery at intervals recommended by the battery manufacturer's instructions.

4.4.7 Uncoupling the Gooseneck Trailer with Ball Coupler

Follow these steps to uncouple your gooseneck hitch trailer from the tow vehicle:

- Block trailer tires to prevent the trailer from rolling, before jacking the trailer up
- Disconnect the electrical connector
- Disconnect the breakaway brake switch lanyard
- Disconnect the safety chains from the tow vehicle
- Move the spring-loaded gooseneck receiver lock plate locking pin to the OPEN position (see "Gooseneck Ball Receiver and Height Adjustment" figure)
- Rotate the lock plate to a position that permits the gooseneck ball to exit the receiver
- Before releasing drop-leg jack, make certain ground surface below jack base will support the trailer tongue load
- Rotate the drop leg plunger pin handle so that the plunger pin is released from the drop leg
- Keep feet and hands clear of drop leg base
- Rotate the plunger pin handle so that the plunger pin is attempting to disengage the drop leg
- Re-engage the plunger pin. Push it in by hand if necessary. The bent part of the plunger pin handle must be touching the plunger pin housing
- If your trailer has two drop leg jacks, lower them both to the same level, following the above instructions
- Release the handle (or crank) from its holder and engage it with the jack shaft (see "Drop Leg Jack" figure)
- Rotate the handle (or crank) from its hold and engage it with the jack shaft (see "Drop Leg Jack" figure)
- Rotate the handle (or crank) clockwise to slowly extend the jack and transfer the weight of the trailer tongue to the jack
- On two speed jacks, pushing the handle shaft toward the gearbox can perform rapid extension. This shifts the gearbox into a highspeed mode
- When the drop leg base contacts the ground, shift the gearbox into low gear mode by pulling or pushing on the handle shaft until it locks into low gear

COUPLING TO THE TOW VEHICLE

NOTICE

NOTICE- Do not use high gear to lift the trailer; the drop leg jack mechanism can be damaged.
High gear is used only to rapidly move the drop leg base into contact with the ground.

- Continue to extend the jack(s), making sure that the ground is providing stable and level support for the trailer
- After the jack(s) are extended and the gooseneck ball receiver is well clear of the gooseneck ball, to permit driving the tow vehicle away, disengage the handle from its shaft and return to its holder

4.5 TRAILER WITH FIFTH-WHEEL COUPLER AND DROP-LEG JACK

A fifth wheel coupler on the trailer (see “Trailer with a Kingpin Coupler” figure 3.1 and “Fifth Wheel Coupler” figure 3.2) connects to a kingpin that is installed on the tow vehicle. A Fifth Wheel Coupler on the tow vehicle (Figure 3.2) connects to a Kingpin that is installed on a trailer.

A fifth wheel coupler includes a flat load-bearing plate with a slot, and a mechanism inside the slot that “grips” the kingpin.

We have installed a fifth wheel coupler that is suitable for the size and weight of the trailer. You must provide a kingpin and kingpin plate that match the fifth wheel, and that is rated for the Gross Vehicle Weight Rating (GVWR) of your trailer.

4.5.1 Before Attempting to Tow the Trailer

- Be sure all deadbolt locks are engaged



WARNING

- **WARNING- Engage deadbolt lock when towing trailer to prevent accidental door opening while in transit.**

- Be sure the size and rating of the fifth wheel and kingpin match
- Wipe the kingpin clean and inspect it visually and by feel for flat spots, cracks and pits. Check the condition of the kingpin mounting in the bed of the tow vehicle.

COUPLING TO THE TOW VEHICLE

• WARNING

- **WARNING- A worn, bent, cracked or corroded kingpin can fail while towing, and may result in death or serious injury.**
- **Before coupling the trailer, inspect the kingpin and kingpin plate for wear, bending, cracks or corrosion; and replace worn or damaged kingpin.**

- Be sure the fifth wheel mechanism operates freely
- Lubricate the fifth wheel plate surface with a light coat of Lithium-base, waterproof grease
- Be sure the fifth wheel and kingpin fasteners have been tightened and any welds are solid

• WARNING

- **WARNING- A loose fifth wheel or kingpin can result in uncoupling, leading to death or serious injury. Be sure the fifth wheel and kingpin are tight before coupling the trailer.**

- Be sure the brake line, electrical line, and any other lines are clear of the coupling area. Be sure the locks are open (see “Fifth Wheel Coupler Operation” figure)
- If the tow vehicle is equipped with a tailgate, lower it
- Block the trailer wheels, front and rear
- Make certain that trailer fifth wheel plate is slightly above the kingpin plate on the tow vehicle
- Back tow vehicle up close to the trailer, centering the kingpin in the slot of the fifth wheel
- **STOP** before engaging the coupling

• WARNING

WARNING- If the trailer drops during coupling, death or serious injury may result. There must be no one under the trailer or coupler before or during the coupling operation.

- Adjust the height of the trailer, using the jack, so that the fifth wheel plate just touches the kingpin plate
- Slowly back up the tow vehicle, keeping the kingpin centered in the slot of the fifth wheel. Continue backing up until the fifth wheel locks firmly on the kingpin
- Visually check to confirm that the fifth wheel locks are properly locked onto the kingpin by performing the three checks illustrated in the “Fifth Wheel Coupler Operation” figure
- Attempt to pull forward as an initial test of the closing of the fifth wheel locks

COUPLING TO THE TOW VEHICLE

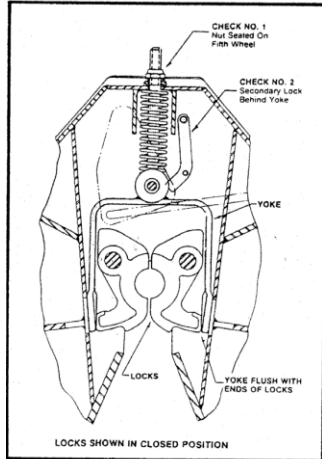

FIGURE 6A

- CHECK 1**
The adjustment nut must be seated against the fifth wheel (see Figure 6A).
- CHECK 2**
The secondary lock must be behind the yoke (see Figure 6A).
- CHECK 3**
The fifth wheel must be flush with the kingpin plate (see Figure 7A).

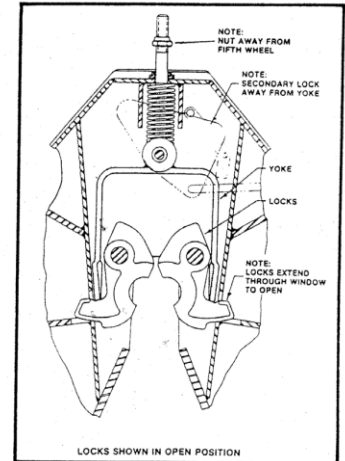

FIGURE 6B

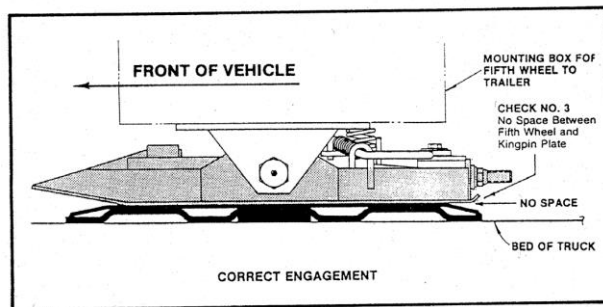

FIGURE 7A

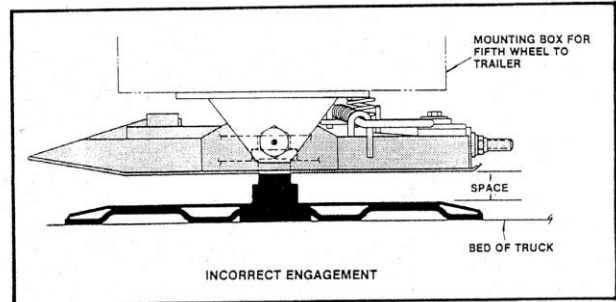

FIGURE 7B

WARNING

WARNING- An improperly coupled fifth wheel can come loose, resulting in death or serious injury.

Do not tow the trailer until all the visual checks have been performed:

- Adjustment nut against fifth wheel.
- Secondary lock behind yoke.
- Fifth wheel against kingpin plate.

4.5.2 Raise the Drop Leg Jack

A trailer having a fifth wheel coupler will be outfitted with one or two drop leg jacks for raising and lowering the fifth wheel coupler. Because we use several drop leg jack mechanisms, the general instructions below may vary slightly from the jack manufacturer's instructions. If the trailer jack on your trailer does not resemble the jack shown in the figures, follow the jack instructions provided by

the jack manufacturer. If you do not have these instructions, call Doolittle Trailer Mfg., Inc. at 800-654-4948 for a free copy.

Rotate the jack handle counter-clockwise. This will slowly retract the jack and transfer the weight of the trailer tongue to the towing vehicle. When the drop leg base is no longer resting on the ground, the towing vehicle hitch is holding all the weight of the trailer tongue. Continue retracting the jack to its fully retracted position.

Return the drop legs to their upper positions. The drop legs are held in the lowered position with a plunger pin. Rotating the plunger pin while pulling it outward about $\frac{3}{4}$ inch will cause it to come out of the engagement with the drop leg.

Raise the Tailgate

Pick up the trailer wheel blocks.

4.5.3 Connect the Electrical Cables

Connect the trailer lights to the tow vehicle's electrical system using the electrical connectors.

Check all lights for proper operation:

- Clearance and Running Lights (Turn on tow vehicle headlights)
- Brake Lights (Step on Tow vehicle brake pedal)
- Turn Signals (Operate tow vehicle directional signal lever)

Check brakes for proper operation: While towing the trailer at less than 5 m.p.h., manually operate the electric brake controller in the tow vehicle cab. You should feel the operation of the trailer brakes.

4.5.4 Attach and Test the Breakaway Brake System

If the coupler fails, a properly connected and working breakaway brake system will apply electric brakes on the trailer.

The breakaway brake system includes a battery, a switch with a pull pin, and a breakaway brake lanyard. Read and follow the instructions here as well as the instructions that have been prepared by the breakaway brake controller manufacturer. If you do not have these instructions, call Doolittle Trailer Mfg., Inc. at 800-654-4948 for a free copy.

The breakaway brake system is not fitted with a charging facility that draws power from the tow vehicle. You must periodically charge the battery to keep the breakaway brake system in working order.

Visually inspect the breakaway brake system for broken parts.

Connect the pull pin cable to the tow vehicle. Do **not** connect to kingpin or its support.

To test the break-away battery remove the pull pin from the switch and attempt to pull the trailer forward. You should feel the trailer resisting being towed, but the wheels will not necessarily lock-up.

COUPLING TO THE TOW VEHICLE

Immediately replace the pull pin. The breakaway brake system battery discharges rapidly when the pull pin is removed.

Do **not** tow the trailer with the breakaway brake system ON because the brake will overheat which can result in permanent brake failure.

If you do not use your trailer for three or more months, or during winter months:

- Store the battery indoors
- Charge the battery every three months

Replace the breakaway brake battery at intervals recommended by the battery manufacturer

4.5.5 **Uncoupling the Fifth-Wheel Trailer with Drop-leg Jack**

Follow these steps to uncouple your fifth wheel hitch trailer from your tow vehicle

- Block trailer tires to prevent the trailer from rolling before jacking the trailer up
- Disconnect the electrical connector
- Disconnect the breakaway brake switch lanyard
- If the tow vehicle has a tailgate, lower it
- Make certain that ground surface below jack base will support trailer tongue load
- Rotate the drop leg plunger pin handle so that the plunger pin is released from the drop leg
- Keep feet and hands clear of the drop leg it will drop to the ground
- Rotate the plunger pin handle so that the plunger pin engaged
- Slowly raise your foot, permitting the drop leg to raise. The plunger pin will engage a hole in the drop leg
- Be sure the plunger pin is fully engaged. Push it in by hand if necessary. The bent part of the plunger pin handle must be touching the plunger pin housing
- If your trailer has two drop leg jacks, lower them both to the same level, following the above instructions

NOTICE

NOTICE- If the drop legs are not set at the same level, one of the drop leg jacks can be overloaded and can be damaged.

- Release the handle (or crank) from its holder and engage it with the jack shaft
- Rotate the handle (or crank) clockwise to slowly extend the jack and transfer the weight of the trailer tongue to the jack
- On two speed jacks, pushing the handle shaft toward the gearbox can perform rapid extension. This shifts the gearbox into a highspeed mode

COUPLING TO THE TOW VEHICLE

NOTICE

NOTICE- Do not use high speed to lift the trailer, the drop leg jack mechanism can be damaged. High speed is used only to rapidly move the drop leg base into contact with the ground.

- When the drop leg base contacts the ground, shift the gearbox into low speed mode by pulling out on the handle shaft until it locks into low gear
- Continue to extend the jack(s), making sure that the ground is providing stable and level support for the trailer
- Turn the crank two or three turns to take some of the weight of the coupling. Do **not** raise the fifth wheel off the kingpin plate
- After the jack(s) are extended enough to permit driving the tow vehicle away, disengage the jack handle from its shaft and return it to its holder. Do NOT drive the tow vehicle yet
- Open the fifth wheel locks by:
 - o pulling the release handle
 - o using a separate pipe release handle to engage the solid stud on the secondary lock (see “Fifth Wheel Coupler Operation” and “Opening Fifth Wheel Locks” figures)
- Slowly drive the tow vehicle away from the trailer
- Raise the tow vehicle tailgate

4.6 TONGUE WEIGHT

It is critical to have a portion of the trailer load carried by the tow vehicle. That is, the trailer tongue must exert a downward force on the hitch. This is necessary for two reasons. First, the proper amount of tongue weight is necessary for the tow vehicle to be able to maintain control of the tow vehicle/trailer system.

If, for example, the tongue exerts an upward pull on the hitch, instead of pushing down on it (because the trailer is overloaded behind its axle(s)), the rear wheel of the tow vehicle can lose traction or grip and cause loss of control. Also, even if there is some weight on the tongue, but not enough weight on the tongue, the trailer can become unstable at high speeds. Remember, the faster you go the more likely the trailer is to sway. If, on the other hand, there is too much tongue weight, the tow vehicle is prone to jack-knife.

Furthermore, the front wheels of the tow vehicle can be too lightly loaded and cause loss of steering control and traction, if the front wheels are driving.

In addition to tow vehicle control, tongue weight is necessary, to insure the trailer axle(s) do not exceed their Gross Axle Weight Rating (GAWR).

The table in 1.2.10 gives recommended percentages.

4.7 CHECKING TONGUE WEIGHT

To check the tongue weight, the tow vehicle and trailer must be on level ground, as they will be when the trailer is being towed.

For lighter trailers the recommended method of checking tongue weight is to use an accessory called a “tongue weight scale.” If a tongue weight scale is not available from your dealer, call Doolittle Trailer Mfg., Inc. at 800-654-4948 for assistance.

COUPLING TO THE TOW VEHICLE

An alternate method of checking tongue weight involves the use of a bathroom scale. The loaded trailer must be on a smooth and level surface, and you must block the trailer wheels, front and rear.

Bathroom Scale Method for Checking Tongue Weight



WARNING

WARNING- An unrestrained trailer can fall off its support, resulting in serious injury or death. Before checking tongue weight, block trailer wheels, front and rear.

- Raise the tongue of the trailer with the jack. Place a bathroom scale on the ground, directly below the coupler. Place a strong block support (such as a cement block) on the scale – note the scale reading for the weight of the block support

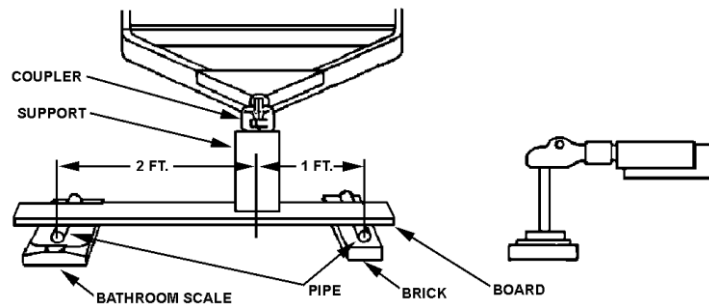

- Lower the tongue until the coupler rests on the block support and the jack is $\frac{1}{2}$ inch above the ground
- The scale reading, minus the weight of the block support is the tongue weight
- If the tongue weight exceeds the capacity of a bathroom scale, you can use “leverage” to divide the tongue weight between the bathroom scale and another support (see “Checking Tongue Weight” figure)
- Raise the tongue of the trailer with the jack
- Arrange a brick, 2 x 4 (or 4 x 4) board, bathroom scale and pipes as shown in “Checking Tongue Weight” figure. The brick should be about the same thickness as the bathroom scale
- Leave a 3-foot distance between the pipes and place the coupler about 2 feet from the pipe on the bathroom scale
- Place a strong block support (such as a cement block) on the board. Note the weight indicated on the scale
- Lower the tongue until the coupler rests on the block support and the jack is $\frac{1}{2}$ inch above the ground
- Subtract the scale reading with the block and board alone from the scale reading with the trailer on the block. Multiply the result by 3 to get the actual tongue weight

Example: Scale reading with block and board alone = 10 lbs.

Scale reading with trailer coupler resting on board = 50 lbs.

Actual tongue weight: $(50-10) \times 3 = 120$ lbs.

COUPLING TO THE TOW VEHICLE

For heavier trailers it is easier to go to a truck stop where there is a “certified” scale. Pull only the tow vehicle onto the scale and get the weight. This weight must be less than your tow vehicle’s GVWR. Pull the trailer onto the scale and decouple it from the tow vehicle, leaving just the trailer on the scale. Get a “ticket”, which lists the total trailer weight. Re-connect the trailer to your tow vehicle and drive the tow vehicle wheels off the scale, just leaving the trailer axles on the scale. Get a second “ticket”, which lists the trailer’s axle weight. Simple subtract the axle weight from the total weight to determine the hitch weight.

While you are at the scale, you should weigh the entire combination vehicle. This result should be less than the Gross Combined Weight Rating (GCWR) for your towing vehicle. Some scales allow you to get individual axle weights also. If this is possible, get the vehicle being towed front and rear axle weights to make sure they are in the same proportion as the tow vehicle alone, and that the rear axle is not overloaded. This is the best way to check that a weight distribution (or load leveling) hitch is adjusted properly, i.e., you have the proper number of chain links attached to the snap-up brackets.

Couple the trailer to the tow vehicle before loading. The tongue of a bumper pull trailer can rise during loading, before the cargo is properly distributed.

Do not transport people, containers of hazardous substances, cans or containers of flammable substances. However, fuel in the tank of an off-road vehicle, or a car or motorcycle, etc., may be carried inside of your enclosed cargo trailer.



WARNING

WARNING- Do not transport people inside the trailer, even if it has living quarters. The transport of people puts their lives at risk and may be illegal.

5.1 LOADING AN ENCLOSED TRAILER

Enclosed trailers may be fitted with a drop ramp door. The weight of the drop ramp door is partially held by a spring and cable counterbalance assembly. If the spring and cable counterbalance assembly is out of adjustment or worn out, it will not provide the expected assistance for slow and careful lowering and raising ramp.



WARNING

WARNING- A spring and cable counterbalance can inflict serious injury if it breaks, or if incorrectly adjusted. Inspect the cable and cable ends each time the door is operated. Do not attempt to service the counterbalance. Take the trailer to your dealer for service.

LOADING AND UNLOADING A TRAILER

Carefully lower the drop ramp to the ground.

Load the cargo up the drop ramp and into the trailer, with approximately 60% of the cargo in the front half of the trailer. If the trailer has living quarters, the cargo area of your trailer will have ventilation openings near the floor. Do not block these ventilation openings. These openings are provided to exhaust potentially deadly fumes.



WARNING

WARNING- Accumulation of hazardous fumes can cause death or serious injury. Do not block access to ventilation ports.

Secure the cargo to the trailer using appropriate straps, chains and tensioning devices.

Close the drop ramp door and secure the trailer door catch using a linchpin or other locking device, so that the catch and door cannot open while the trailer is being towed.



WARNING

WARNING- If the door opens, your cargo may be ejected onto the road, resulting in death or serious injury to other drivers. Always secure the door latch after closing. Place a linchpin in the catch.



WARNING

WARNING- Improper weld repair will lead to early failure of the trailer structure and can cause serious injury or death. Do not repair cracked or broken welds unless you have the skills and equipment to make a proper repair. Have the welds repaired by your dealer.



WARNING

WARNING- DO NOT Adjust Ramp Door Spring. Professionals ONLY!



WARNING

WARNING- Do not damage ramp door cables. Inspect ramp door cables and brackets once per month, if damage is found take to professional for repairs.

CHECKING TRAILER FOR EACH TOW

5.1.1 Preparing the Trailer for Loading

Before loading cargo into your enclosed trailer, inspect the interior of the trailer.

Enclosed trailers may be fitted with “D”-ring hold-downs, and/or a track system that can be used to secure the cargo. Inspect the “D”-rings and track system for looseness or signs of bending before loading the cargo onto the trailer.

6.1 PRE-TOW CHECKLIST

Before towing, double-check all these items: See section 10.1, “Inspection, Service & Maintenance Summary Charts,” for more information.

- Tires, wheels and lug nuts (see the “Major Hazards” section starting on page 1 of this manual)
- Tire Pressure. Inflate tire on trailer and tow vehicle to the pressure stated on the VIN / Certification label.
- Coupler secured and locked (see the “Coupling and Uncoupling the Trailer” section of this manual)
- Safety chains properly rigged to tow vehicle, not to hitch or ball (see the “Coupling to the Tow Vehicle” chapter of this manual)
- Test of lights: Tail, Stop, and Turn Lights
- Test trailer brakes.
- Safety breakaway switch cable fastened to tow vehicle, not to safety chains (see the “Coupling to the Tow Vehicle” chapter of this manual)
- Cargo properly loaded, balanced and tied down (see the “Loading the Trailer” chapter of this manual)
- Tongue weight and weight distribution set-up.
- Doors and gates latched and secured
- Fire extinguisher
- Flares and reflectors

6.2 MAKE REGULAR STOPS

After each 50 miles, or one hour of towing, stop and check the following items:

- Coupler secured
- Safety chains are fastened and not dragging
- Cargo secured
- Cargo door latched and secured

ACCESSORIES

7.1 ACCESSORIES

This chapter provides some basic information for the safe operation of several accessories. For many accessories, such as generators and LP appliances, the manufacturer of the accessory has also provided instructions. You must read and follow these instructions before using the accessory. If you are uncertain whether you have all the instructions, call Doolittle Trailer Mfg., Inc. at 800-654-4948 before operating the accessory. The following accessories are described in this section:

- Gasoline (or LP) and Diesel Generators
- Accessory Battery
- “Shore Power” connections which provide power by “plugging the trailer in” to an external source of electrical power
- LP Gas Fuel System
- LP Gas System Troubleshooting
- Vending or Accessory Doors
- Electric-powered Landing Gear

Many accessories introduce the risk of fire and carbon monoxide poisoning. If you have an accessory on your trailer, make sure you have a fire extinguisher charged and ready before operating the accessory. Check the fire extinguisher at least once a month. If the fire extinguisher is discharged even partially, it must be recharged. Follow the fire extinguisher manufacturer’s instructions for recharging the extinguisher after use.

7.2 GASOLINE-POWERED ELECTRIC GENERATOR

If you decide to get your trailer is equipped with a generator you must have and follow the generator manufacturer’s instructions. Carbon monoxide gas is present in the exhaust of all gasoline and diesel engines, as well as from other burning fuels such as LP gas and charcoal.

Carbon Monoxide is an odorless gas that can cause death. Be certain exhaust from any running engine or burning fuels cannot accumulate in areas where people or animals are likely to be present. Conditions that can redirect exhaust fumes are, for example:

- Being drawn in by fans or ventilators operated in a trailer
- Prevailing wind
- Being trapped between adjacent trailers, vehicles or buildings
- Being trapped between or in a snow bank or other materials that can redirect fumes

ACCESSORIES

WARNING

WARNING- Operating gasoline and diesel generators can lead to death or serious injury by:

- Carbon Monoxide
- Fire and Explosion
- Electrocutation
- **Have a working carbon monoxide detector in the accommodation spaces before operating a generator. Check before each operation.**

Do not refuel a running generator or refuel near ignition sources.

WARNING

WARNING- Do not operate portable heaters or generators inside an enclosed trailer without adequate ventilation as death or serious injury may occur.

Before starting the generator, check fuels and oil levels. The generator may have to run for two or three minutes before it allows drawing electricity from it. Read the generator instruction manual. If you do not have the generator instruction manual, call Doolittle Trailer Mfg., Inc. at 800-654-4948 for a free copy.

Never exceed the capacity of the generator. Before turning off the generator, remove the electrical load and let the engine to run for two or three minutes to cool the generator.

7.3 ACCESSORY BATTERY

Your trailer may be outfitted with an accessory battery that operates lighting, electric landing gear, dump body, slide-outs or other accessories. An accessory battery may be kept charged either by the tow vehicle or by the generator or shore power. A disconnect switch may be provided to disconnect the accessory battery when you do not plan to be using the trailer for an extended period, such as seasonal storage. If there is no disconnect switch, then remove the cables from the battery terminals. The accessory battery must be kept in a charged condition during storage. The battery could freeze and break if it becomes discharged.

7.4 SHORE POWER

Shore power is the delivery of electrical power from another source to a power inlet on your trailer. To connect your trailer to this source, you must have a “shore power” cord, specifically designed for this use. **DO NOT USE AN ORDINARY EXTENSION CORD.** The trailer end of this cord is connected to an electrical box on the trailer, sometimes referred to as a “motor base.” This box contains circuit breakers and/or fuses and may include a power converter to change the shore power (usually 110 volts alternating current) into 12 volts direct current.

Do not assume that a shore power supply is correctly wired. Shore power may have incorrect polarity or not have the safety ground. Before connecting your trailer, you should test shore power by using a polarity and ground tester, which can be purchased at electronic stores.

ACCESSORIES

If you have shore power, your trailer may be fitted with Ground-Fault Interrupting outlets (GFI). If you have GFI protection, you must periodically test the outlets by pressing the “TEST” button that is located on the GFI-equipped outlet.



WARNING

WARNING- Shore power poses a risk of death due to electrocution or fire

- Always use an electrical cord specifically designed for shore power connection. Never use an ordinary extension cord.
- Always connect the electrical cord to a grounded source of shore power.
- Do not remove the “third prong” from the shore power plug.
- Connect only to source of proper voltage.
- Make certain polarity is correct.
- Do not overload electrical circuits.
- Always replace fuses or circuit breakers with correct rating.

7.5 LP GAS FUEL SYSTEM

LP gas systems are installed to operate a variety of appliances, such as stoves, refrigerators, heating units and electrical generators. The exhaust fumes from burning LP gas contain carbon monoxide. Carbon monoxide gas is odorless and can cause death or serious brain injury if inhaled. The exhaust from LP appliances must be directed to the outdoors. You must have an operating carbon monoxide detector in the living quarters of your trailer.



WARNING

WARNING- You can die or be brain damaged by Carbon Monoxide. Make certain the exhaust from LP appliances is directed to the outdoors. Have a working carbon monoxide detector in the accommodation spaces of your trailer before operating any LP gas appliance. Do not operate portable grills or stoves inside the trailer.

ACCESSORIES

When used for the first time, or after a period of storage, the LP gas lines will be full of air and must be purged of air, before the appliances will stay lit. Have the LP gas lines purged by your trailer dealer, or an LP gas dealer.

An LP gas system is designed to operate with a supply of LP gas only, NOT natural gas. A natural gas supply is unsafe for the system's pressure regulation devices.



WARNING

WARNING- Risk of death due to fire or explosion. Only connect an LP gas system to a supply of LP gas, NOT natural gas. Do not store LP gas tanks inside the trailer. Only fill an LP gas tank 80% full. Only fill the tank with LP gas (butane or propane). Overfilled tanks can release gas and cause an explosion.

Always keep the shutoff valve on your LP gas tank closed, except when you are operating an LP gas appliance. Before opening the LP shutoff valve, turn off all LP gas appliances. If an appliance is on when you open the shutoff valve, LP gas will accumulate in the trailer, which can result in an explosion.

Do not use a wrench to open or close the shutoff valve. If the shutoff does not completely stop the flow of LP gas when it is hand-tightened, replace the shutoff valve.

LP gas leaks can result in fire or explosion. If your trailer is equipped with an LP gas system, it must also be equipped with an LP gas detector. The LP gas detector will be located near the floor to detect the heavier-than-air LP gas. If a leak is suspected, use a soapy water solution to search for the leak. Do not use a solution that contains ammonia or chlorine (common in window and other household cleaning compounds), because those chemicals will cause LP piping corrosion.



WARNING

WARNING- Risk of fire or explosion If LP gas is detected (by smell or by the LP gas detector):

- Do not touch electrical switches
- Extinguish flames and pilot lights
- Open doors for ventilation
- Shut off LP gas supply at the LP tank
- Leave the area until odor clears

Correct the source of LP gas leakage before using LP appliances.

Do not use a flame to locate the source of an LP gas leak.

LP gas is either propane or butane that is compressed into liquid form. LP gas must be completely vaporized before being burned. Butane gas will not operate if the outside temperature is below 32 degrees Fahrenheit.

ACCESSORIES

NOTICE

NOTICE- Use Butane only when the temperature is above freezing (32 degrees F). Propane gas will operate at temperatures as low as minus 44 degrees Fahrenheit (-44 F).

Keep the regulator for the LP gas system (located near the LP gas tank) covered with a guard to protect it from road debris.

LP gas is prohibited on some roadways, bridges and tunnels. Check a map and with Departments of Transportation (or with the AAA) for travel routes that do not have such restrictions. If you store your trailer, make sure that all appliances and generators are disabled prior to storing.

7.6 LP GAS SYSTEM TROUBLESHOOTING

Having liquid “gas” at your appliance is an indication that the LP gas tank is overfilled, or that the temperature is too cold.

If your LP gas appliances do not stay lit, it might be because your LP gas system is contaminated with air or moisture. Many LP gas vendors have facilities to purge the air from an LP gas system.

If your LP gas system is not providing gas, even when the shutoff valve is open, it might be because the LP gas regulator has frozen water in it.



WARNING

WARNING- Risk of fire or explosion

Never use a flame, heat lamp or hair dryer to thaw an LP gas regulator.

Use an incandescent light bulb.

Do not remove the regulator cover or attempt to service the LP gas regulator.

7.7 VENDING AND ACCESSORY DOORS

A vending or accessory door opens vertically and has a hinge along its top edge. These heavy doors are equipped with spring-assisted lifting, usually with a device known as a “gas spring.” The gas spring lifting device is not designed to hold a vending door up. You must use the provided solid “prop rods” to hold a vending door in the open position.



WARNING

WARNING- Gas springs lose their lifting capability with age and cold weather; and can cause the door to fall, resulting in injury. Always hold the door open until the prop rods are in place. Always use prop rods to hold vending or accessory doors open. Be prepared to hold the weight of the door when removing the prop rod.

7.8 ELECTRIC POWERED LANDING GEAR

The landing gear (also known as the jack) on your trailer may be powered with an electric motor. The landing gear is operated up or down using controls located near the landing gear. If the motor does not operate, such as when the battery is fully discharged, the landing gear can be operated manually with a socket wrench

8.1 INSPECTION, SERVICE, & MAINTENANCE SUMMARY CHARTS

You must inspect, maintain and service your trailer regularly to insure safe and reliable operation. If you cannot or are unsure how to perform the items listed here, have your dealer do them. Note: In addition to this manual, also check the relevant component manufacturer's manual.

WARNING

Never crawl under your trailer unless it is on firm and level ground and resting on properly placed and secured jack stands.

INSPECTIONS, SERVICE, & MAINTENANCE

Inspection and Service Each Month		
Item	Inspection/Service	Manual Selection Reference
Lubrication	Lubricate doors and dump body pivot points	Section 10.2.11

Inspection and Service Before Each Use		
Item	Inspection/Service	Manual Section Reference
Breakaway Brakes -Electric -Hydraulic	Check Operation Check Fluid Level	Sections 4.3.4 & 4.4.5 Section 10.2.3.6
Breakaway Battery	Fully Charged, connections clean	Sections 4.4.4 & 4.4.5 Section 10.2.3.3
Brakes, All Types	Check Operation	Section 8.3
Shoes and Drums	Adjust	Section 8.2 10.2.3.2
Brakes, Hydraulic- Vacuum Actuated	Check gauge for proper vacuum of 18 In. Hg. (inches of mercury)	Section 10.2.3.6
Coupler and Hitch Ball	Check for cracks, pits, and flats. Replace w/ Ball & Coupler having the GVW rating. Grease Check locking device & replace when worn.	Section 4.3.1.2 Section 4.3.1.2 Section 10.2.4.1
Gooseneck Ball	Check for cracks, pits, and flats. Replace w/ Ball & Coupler having the GVW rating. Grease Check locking device & replace when worn.	Section 4.4.2 Section 4.4.2 Section 10.2.4.3
Ring & Pintle	Check for cracks, pits, and flats. Replace w/ Ball & Coupler having the GVW rating. Grease Check locking device & replace when worn.	Section 4.3.2.1 Section 4.3.2.1 Section 10.2.4.2
Safety Chain(s) & Hooks	Check for wear and damage	Sections 4.3.3 & 4.4.4
Tires	Check tire pressure when cold. Inflate as needed.	Sections 7.1 & 10.2.8
Wheels – Lug Nuts (Bolts) & hub	Check for tightness. Tighten. For new and remounted wheels, check torque after first 10,25 & 50 miles driving and after any impact.	Section 7.1 Sections 8.1 & 10.2.12

Inspection and Service Every 6 months or Every 6,000 Miles		
Item	Inspection/Service	Manual Selection Reference
Tires	Rotate @ 5,000 miles	Section 10.2.8
Brakes, electric -Magnets -Controller (in tow vehicle)	Check wear and current draw Check power output (amperage) and modulation	Section 10.2.3.5 Section 10.2.3.4 See Controller Manufacturer's Manual
Tires	Inspect tread and sidewalls thoroughly. Replace tire when treads are worn, when sidewall has a bulge, or sidewall is worn	Section 10.2.8 Section 10.2.8

Inspection and Service each Year or 12,000 Miles		
Item	Inspection/Service	Manual Selection Reference
Brakes, all types -Shoes and Drums	Check for scoring and wear. Replace per manufacturers specifications.	Section 10.2.3.1 See Brake Manufacturer's Manual
Jack, Drop-leg	Grease gears at top.	See Jack Manufacturer's Manual
Structure -Frame members -Welds	Inspect all frame members, bolts & rivets. Repair or replace damaged, worn or broken parts. Inspect all welds. Repair as needed.	Section 10.2.1 Section 10.2.2.2
Wheels -Wheel Bearings -Rims	Disassemble / inspect / assemble and repack. Replace promptly if immersed in water Inspect for cracks & dents. Replace as needed.	Section 10.2.10 & See Axle Manufacturer's Manual Section 10.2.9
Structure -Axle Attachment Bolts	Check by Dealer	Section 10.2.1



Worn or broken suspension parts can cause loss of control and injury may result. Have trailer professionally inspected annually and after any impact.

INSPECTIONS, SERVICE, & MAINTENANCE

8.2



Broken or damaged fasteners or welds can cause injury or damage to trailer and contents. Inspect for and repair all damaged parts at least once a year.

Inspections and Service Instructions

8.2.1 Axle Bolts, Frame, Suspension, & Structure

To perform many of the inspection and maintenance activities, you must jack up the trailer. When jacking and using jack stands, place them to clear wiring, brake lines, and suspension parts (springs, torsion bars, etc.). Place jacks and jack stands under the outer frame rail to which the axles are attached.

To perform many of the inspection and maintenance activities, you must jack up the trailer. When jacking and using jack stands, place them to clear wiring, brake lines, and suspension parts (springs, torsion bars, etc.). Place jacks and jack stands under the outer frame rail to which the axles are attached.

8.2.2 Trailer Structure

Because the trailer floor receives the most abuse, it will most likely corrode before any other part of the structure.

Using a power washer and a detergent solution, wash the floor and walls of the trailer. Rinse the trailer floor and walls.

8.2.2.1 Fasteners and Frame Members

Inspect all the fasteners and structural frame members for bending and other damage, cracks, or failure. Repair or replace any damaged fastener and repair the frame member. If you have any questions about the condition or method of repair of fasteners or frame members, get the recommendation of, or have the repair done by, your dealer.



Broken or damaged fasteners or welds can cause injury or damage to trailer and contents. Inspect for and repair all damaged parts at least once a year.

8.2.2.2 Welds

All welds can crack or fail when subjected to heavy loads or movement of cargo that was not properly tied to prevent movement. Any time that you know or suspect that the trailer has been subjected to heavy loads or movement of cargo, immediately inspect the welds and fasteners for damage. To prevent severe damage to your trailer, inspect all the welds for cracks or failure at least once a year.

8.2.2.3 Brake Shoes and Drums

Properly functioning brake shoes and drums are essential to ensure safety. You must have your dealer inspect these components at least once per year, or each 12,000 miles. The brake shoes must be adjusted after the first 200 miles of use, and each 3,000 miles thereafter. Most axles are fitted with a brake mechanism that will automatically adjust the brake shoes when the trailer is “hard braked” from a rearward direction. Read your axle and brake manual to see how to adjust your brakes. If you do not have this manual, call Doolittle Trailer Mfg., Inc. at 800-654-4948 for a free copy.

8.2.2.4 Manually Adjusting Brake Shoes

Some braking systems are not automatically adjusted by hard stopping. These brakes require manual adjustment. The following steps apply to adjust most manually adjustable brakes. Read your axle and brake manual to see how to adjust your brakes. If you do not have this manual, call Doolittle Trailer Mfg., Inc. at 800-654-4948 for a free copy.

Jack up the trailer and secure it on adequate capacity jack stands. Be sure the wheel and brake drum rotate freely. Remove the adjusting-hole cover from the adjusting slot on the bottom of the brake backing plate. With a screwdriver or standard adjusting tool, rotate the star wheel of the adjuster assembly to expand the brake shoes. Adjust the brake shoes out until the pressure of the linings against the drum makes the wheel very difficult to turn. Note: Your trailer maybe equipped with drop spindle axles. See axle manual for your axle type. You will need a modified adjusting tool for adjusting the brakes in these axles. With drop spindle axles, a modified adjusting tool with about at an angle of about eighty degrees should be used. Rotate the star wheel in the opposite direction until the wheel turns freely with a slight drag. Replace the adjusting-hole cover. Repeat the above procedure on all brakes. Lower the trailer to the ground.



WARNING

8.2.3

If electric breakaway brakes do not operate when trailer is uncoupled from the tow vehicle, death or serious injury can occur. Check emergency breakaway brake system BEFORE each tow.

Breakaway Brakes

Two different types of electric brakes may be present on the trailer. An emergency electric breakaway system, which acts only if the trailer comes loose from the hitch and the breakaway pin is pulled. The other brake is an electric braking system that acts whenever the brakes of the tow vehicle are applied.



WARNING

Vacuum gauge in tow vehicle must be at or above 18 In. Hg. If not, brakes may be rendered inoperable and unsafe. Low vacuum will cause damage to the brake system.

8.2.3.1 Breakaway Battery

This battery supplies the power to operate the trailer brakes if the trailer uncouples from the tow vehicle. Be sure to check, maintain and replace the battery according to the battery manufacturer's instructions.

8.2.3.2 Breakaway Switch

This switch causes the breakaway battery to operate the electric brakes if the trailer uncouples from the tow vehicle. The lanyard for the pull pin is connected to the tow vehicle, and the switch is connected to the trailer. To check for proper functioning of the switch, battery and brakes, you must pull the pin from the switch and confirm that the brakes apply to each wheel. You can do this by trying to pull the trailer with the tow vehicle, after pulling the pin. The trailer brakes may not lock, but you will notice that a greater force is needed to pull the trailer.

8.2.4 Tow Vehicle Operated Electric Brakes

The electric brakes that operate in conjunction with the tow vehicle brakes must be "synchronized" so that braking is properly distributed to the tow vehicle brakes and the trailer brakes. For proper operation and synchronization, read and follow the axle/brake and the brake controller manufacturers' instructions. If you do not have these instructions, call the manufacturer of the brake control for a free copy.

8.2.5 Magnets for all Electric Brakes

To make certain an electrically-operated braking system will function properly, you must have your dealer inspect the magnets at least once a year, or each 12,000 miles. See the brake manual for wear and current inspection instructions.

8.2.6 Hydraulic Brakes (vacuum, air or electric operated)

If your trailer has hydraulically-operated brakes, they function the same way the hydraulic brakes do on your tow vehicle. The hydraulic braking system must be inspected by a dealer, at least as often as the brakes on the tow vehicle, but no less than once per year. This inspection includes an assessment of the condition and proper operation of the wheel cylinders, brake shoes, brake drums and hubs.

8.2.7 Air Pressure-Operated Hydraulic - Air/hydraulic braking systems are typically used when the tow vehicle has a diesel engine. The tow vehicle has an air compressor that routes the air to an air/hydraulic mechanism, which sends brake fluid to the wheel cylinders.

The air pressure gauge in your tow vehicle indicates the current air pressure. See your tow vehicle manual for the proper air pressure.

INSPECTIONS, SERVICE, & MAINTENANCE

You must check the fluid level in the master cylinder reservoir at least every three months. If you tow your trailer an average of 1,000 miles per month in a hot and dry environment, you must check the brake fluid level once a month. The brake fluid reservoir is located on the tongue of the trailer or near the gooseneck. Fill with DOT 4 brake fluid.

8.2.8 Electrical-Operated Hydraulic - Electric/hydraulic braking systems, which are mounted on the trailer, use a small electrically-driven pump to generate hydraulic pressure, which operates the brake cylinders. Like electrical brakes, an electric/hydraulic braking system is operated by an electrical signal from the tow vehicle.

CONNECTION TO A TOW VEHICLE

9.1 BUMPER PULL & COUPLER BALL

The coupler on the trailer connects to the ball attached to the hitch on the tow vehicle. The coupler, ball and hitch transfer the towing forces between the tow vehicle and the trailer. Before each tow, coat the ball with a thin layer of automotive bearing grease to reduce wear and ensure proper operation; and check the locking device that secures the coupler to the ball for proper operation.

See the coupler manufacturer's manual for other inspection and maintenance activities. If you do not have this manual, call Doolittle Trailer Mfg. Inc. at 800-654-4948 for a free copy.

If you see or feel evidence of wear, such as flat spots, deformations, pitting or corrosion, on the ball or coupler, immediately have your dealer inspect them to determine the proper action to prevent possible failure of the ball and coupler system. All bent or broken coupler parts must be replaced before towing the trailer.

The coupler handle lever must be able to rotate freely and automatically snap into the latched position. Oil the pivot points, sliding surfaces, and spring ends with SAE 30W motor oil. Keep the ball pocket and latch mechanism clean. Dirt or contamination can prevent proper operation of the latching mechanism.

When replacing a ball, the load rating must match or exceed the GVWR of the trailer.

9.1.1 Ring and Pintle

The ring on the trailer connects to the pintle attached to the hitch on the tow vehicle. The ring, pintle and hitch transfer the towing forces between the tow vehicle and the trailer. Before each tow, coat the ring with a thin layer of automotive bearing grease to reduce wear and ensure proper operation; and check the locking device that secures the pintle to the ring for proper operation. See the pintle manufacturer's manual for other inspection and maintenance activities. If you do not have this manual, call Doolittle Trailer Mfg., Inc. at 800-654-4948 for a free copy.

If you see or feel evidence of wear, such as flat spots, deformations, pitting or corrosion, on the ring or pintle, immediately have your dealer inspect them to determine the proper action to prevent possible failure of the ring and pintle system. All bent or broken coupler parts must be replaced before towing the trailer.

The pintle handle lever must be able to rotate freely and automatically snap into the latched position. Oil the pivot points, sliding surfaces, and spring ends with SAE 30W motor oil. Keep the ring pocket and latch mechanism clean. Dirt or contamination can prevent proper operation of the latching mechanism.

When replacing a ring, the load rating must match or exceed the GVWR of the trailer.

CONNECTION TO TOW VEHICLE



WARNING

To avoid collisions, taillights, stoplights and turn signals must work.

9.1.2 Gooseneck Ball Receiver

The gooseneck receiver on the trailer connects to a hitch-mounted ball on the towing vehicle. The receiver, ball and hitch transfer the towing forces between the tow vehicle and the trailer. Before each tow, coat the ball with a thin layer of automotive bearing grease to reduce wear and ensure proper operation; and check the locking device that secures the receiver to the ball for proper operation.

See the gooseneck ball receiver manufacturer's manual for other inspection and maintenance activities. If you do not have a manual for the receiver, call Doolittle Trailer Mfg., Inc. at 800-654-4948 for a free copy. If you see or can feel evidence of wear, such as flat spots, pitting or corrosion, on the ball or receiver, immediately have your dealer inspect them to determine the proper action to prevent possible failure of the ball and receiver system.

When replacing a ball, the load rating must match or exceed the GVWR of the trailer.

9.1.3 Landing Leg or Jack

If a grease fitting is present, you must use a grease gun to lubricate the jack mechanism. Grease the gears in the top of hand-cranked jacks once a year, by removing the top of the jack and pumping or hand packing grease into the gears.



WARNING

Worn, damaged or under-inflated tires can cause loss of control, injury and damage. Check tires before each tow.

9.1.4 Lights and Signals

Before each tow, check the trailer taillights, stoplights, turn signals and any clearance lights for proper operation.

9.1.5 Tires

Before each tow, be sure the tire pressure is at the value indicated on the Certification / VIN label. Tire pressure must be checked while the tire is cold. Do not check the tire pressure immediately after towing the trailer. Allow at least three hours for a tire to cool, if the trailer has been towed for as much as one mile. Replace the tire before towing the trailer if the tire treads have less than 1/16-inch depth or the telltale bands are visible.

A bubble, cut or bulge in a side wall can result in a tire blowout. Inspect both side walls of each tire for any bubble, cut or bulge; and replace a damaged tire before towing the trailer.

INSPECTIONS, SERVICE, & MAINTENANCE

DANGER

DANGER- Risk of death by crushing. Empty dump body before using body prop.

WARNING

Risk of death by crushing. Dump body can drop unexpectedly. Never go under a raised dump body. Use body prop for maintenance.

WARNING

Risk of death by crushing. Make sure dump body is empty. DO NOT manipulate the body safety prop if a person is near the control.

9.1.6 Wheel Rims

If the trailer has been struck, or impacted, on or near the wheels, or if the trailer has struck a curb, inspect the rims for damage (i.e. being out of round); and replace any damaged wheel. Inspect the wheels for damage every year, even if no obvious impact has occurred.

A loose, worn or damaged wheel bearing is the most common cause of brakes that grab.

To check your bearings, jack trailer and check wheels for side-to-side looseness. If the wheels are loose, or spin with a wobble, the bearings must be serviced or replaced.

Refer to the axle manufacturer's information for service and maintenance on the axle.

9.1.7 Lubrication Points – Dump Trailers

The body prop supplied as part of the trailer is to be used only when the dump body is empty. The purpose of the body prop is a back-up to the hydraulic system and will hold the empty dump body in a raised position while performing maintenance on the hoist, trailer body, or the trailer itself.

DO NOT use the body prop to support a loaded dump body.

DO NOT perform maintenance under a raised dump body without first supporting the empty dump body up with the body prop. Pump grease into each fitting (1) on the dump body pivot hinges and rear door hinges (2) every month.

Park the trailer on a firm and level surface. Raise the dump body and hold the body safety prop (3) in the upright position. Lower the dump body so the body safety prop engages the socket on the dump body. Pump grease into the fittings (4) on each end of the cylinder(s) and in the scissor mechanism (if equipped). The number of grease fittings and location on the scissor mechanism will vary by trailer model.

Doolittle Trailer Mfg. Inc. 2017