

HxGN MineProtect CAS 10 Installation Manual

**Technical Reference Manual
Software v10.0**

Version No.0.3
Issued February 2021
English

HxGN MineProtect CAS 10 Installation Manual v0.3

This document and any information or descriptive matter contained therein is communicated in confidence and is the copyright property of Hexagon AB. Neither the whole, nor any extract may be disclosed, loaned, copied, or used in manufacturing or tendering purposes without their written consent.

© 2021 Hexagon AB and/or its subsidiaries and affiliates. All rights reserved. All trademarks or service marks used herein are property of their respective owners. Hexagon's Mining division makes no representation or warranty regarding the accuracy of the information in this publication. This document gives only a general description of the product(s) or service(s) offered by Hexagon's Mining division and, except where expressly provided otherwise, shall not form part of any contract. Such information, the products and conditions of supply is subject to change without notice.

Disclaimer: Illustrations, descriptions, and technical specifications in this document are not binding and are subject to change without notice.

This document is optimized for printing on A4 paper.

Revision History

Date	Document Version	Software Version	Author	
26.1.2021	0.1	10.0	B. Hirtz	initial
2.2.2021	0.2	10.2	B. Hirtz	Version 0.2
16.2.2021	0.3	10.2	B. Hirtz	Version 0.3

Table Of Contents

1	Document Introduction	6
1.1	Document Conventions.....	6
2	Operation Safety Procedures	7
2.1	Contacting Support.....	7
3	Product Introduction	8
3.1	Overview.....	8
3.2	The Collision Avoidance Principle.....	8
3.3	Technology used.....	8
3.4	Limitations of the System.....	9
3.5	Legal Statement and Disclaimer.....	9
4	Hardware Overview	10
4.1	Main Components and Accessories.....	10
5	QC1000 HxGN MineDiscover Smart Antenna	12
5.1	Electrical Specifications.....	12
5.2	Mechanical Specifications.....	13
5.3	Environmental Specifications.....	13
5.4	ISM Radio Specifications.....	13
5.5	UWB ToF Radio Specifications.....	14
5.6	Ethernet.....	14
5.7	Wi-Fi.....	14
5.8	LTE.....	14
5.9	Connector Description.....	15
5.10	Face plate/Label Description.....	16
5.11	User Interface – LED bar.....	16
5.12	Network Capabilities.....	17
5.13	SIM Card and eSIM capabilities.....	17
5.14	General Purpose Input Outputs (GPIOs).....	17
5.14.1	Example Installation Reverse Switch.....	17
5.15	Power Save Mode.....	18
5.16	Installation of QC1000.....	18
5.16.1	Installation of QC1000 with bracket.....	18
5.16.2	Installation of QC1000 with magnetic mount.....	19
5.17	Compliance.....	19
5.17.1	CE – Declaration of conformity.....	19
5.17.2	FCC Statement.....	19
5.17.3	Disposal of Product.....	20
5.17.4	Approved Countries.....	20
6	Displays	21
6.1	QD1400 HxGN MineDiscover Display 5.....	21
6.2	QD200 Remote Display.....	21
6.3	Installation of Displays.....	22
6.4	Installation of QD200 Remote Display.....	23
7	System Installation	24
7.1	General Rules and Best Practices.....	24
7.1.1	Installation.....	24
7.1.2	Connection to Battery.....	24
7.2	Haul Trucks.....	25
7.3	Tracked Vehicles.....	29
7.4	Shovels and Excavators.....	30
7.4.1	Rotating Vehicle with Single Antenna.....	30

7.4.2	Rotating Vehicle with Dual Antenna (Beacon)	30
7.5	Pre-Configuration	31
7.6	Installation Verification	31
7.7	Maintenance Checklist	33
8	Troubleshooting	34
8.1	Error Codes	34
Appendix E: Legal statement		35
9	Glossary	36

1 Document Introduction

The HxGN MineProtect CAS 10 Installation Manual is part of the Hexagon Mining reference manual suite.

The HxGN MineProtect CAS 10 Installation Manual is to be used as a technical reference manual for the hardware installation. Configuration and how to set up the system and features are described in the technical reference manual HxGN MineProtect Configuration Manual. It shall serve the technical personnel to correctly set up installations and enable them to maximize the product's performance.

WARNING:

Operators must be aware of the physical surroundings of their equipment and drive to conditions and mine requirements at all times.

Operating any type of vehicle inside a mine at any time of the day is an inherently dangerous activity which is associated with considerable risks for crew, passengers, third parties, pedestrians, other vehicles and any object in its vicinity. In order to make full and safe use of HxGN MineProtect CAS 10 series products, it is absolutely essential to be fully aware of the risks, operating conditions, restrictions and limitations associated with their use, including to ensure a proper installation and to perform regular software updates. This includes familiarity with and strict adherence to the Hexagon Mining reference manual suite.

It is assumed technical personnel using this manual is familiar with:

- Site-specific safety procedures, Safe Work Procedures (SWPs) and Standard Operating Procedures (SOPs).

Note:

The document uses generic images to show general layout and generic information for various procedures. The site-specific screen layout, menu, and procedure information may vary from what is displayed in the manual.

1.1 Document Conventions

This document uses basic conventions to indicate actions:

Convention Example	Description
Select File > Print	Menu selections, buttons, and icons appear in bold text. In this case, select the File menu and the Print option. Location and capitalization of menu items may vary by mine site.
Ctrl+P	Keyboard shortcut keys. The example indicates to select and hold down the Ctrl key and select the P key.
See xxx Refer to	"See" indicates a reference to another section of this document. "Refer to" indicates reference to another document.
WARNING	Warnings alert the user to dangerous procedures which could cause injury or death.
CAUTION	Cautions alert the user to dangerous procedures which could cause damage to equipment.
Note	Notes supply important information about a procedure which is not covered in the procedure text.

2 Operation Safety Procedures

A vehicle equipped with the HxGN MineProtect CAS 10 System must be operated in the same safe manner as if the HxGN MineProtect CAS 10 System was not installed. The system is not a substitute for normal safe driving procedures and may never be relied upon.

The HxGN MineProtect CAS 10 System will provide no warning for some hazards, such as vehicles, obstacles, and other objects not equipped with properly operating HxGN MineProtect CAS 10.

HxGN MineProtect products are intended as an additional tool in determining potential traffic threats, supporting an alert and conscientious driver. HxGN MineProtect products are never to be used in any application where failure of the products could result in personal injury or material damage. Before using, the latest versions of the respective manuals are to be consulted for familiarization with product operation and limitations.

Hexagon makes no warranties with respect to the product. In no event will Hexagon be liable for lost use, profits, revenue, cost of procurement of substitute goods, or any damages.

Customers agree to indemnify and hold harmless Hexagon, its subsidiaries, and affiliates, and their respective successors and assigns, from and against all third party claims, loss, damage or expense, and any other liabilities whatsoever, which may be incurred by Hexagon. with respect to any of the HxGN MineProtect products.

In addition, Hexagon's current "General Terms and Conditions " apply.

2.1 Contacting Support

For all Hexagon Mining product support:

Contact Method	Details
Web portal	http://hexagonmining.com/customer/portallogin .

3 Product Introduction

3.1 Overview

The main task for HxGN MineProtect series products is to support the operator while he scans the space ahead and around the vehicle with his own eyes, and other (technical) aids. HxGN MineProtect CAS 10 products are simple to use and are designed not to distract the operator from operating the vehicle.

The main components are QC1000 Smart Antenna and as display options QD1400 Display 5 (default) or the QD200 LED Display.



3.2 The Collision Avoidance Principle

The Hexagon collision avoidance device is equipped with a GNSS receiver, additional sensors and transmitter, among which an RF transceiver. The GNSS receiver will provide the unit with a position, speed and heading. This information is continuously broadcasted over the air thanks to the RF transmitter/ receiver.

A vehicle will receive the information from all the surrounding vehicles while transmitting its own information. Based on this information, sophisticated algorithms will determine a collision risk level and indicate it to the operator of the vehicle via the display. At the same time, other vehicles - which do not pose an immediate collision risk - are shown on the display for the purpose of traffic awareness around the vehicle and to allow the operator to avoid risky situation well ahead.

As every vehicle has different dynamics and every mine has different rules, HxGN MineProtect CAS 10 provides a list of features and configuration possibilities which can custom tailored to the needs of our customers.

3.3 Technology used

The Hexagon MineProtect CAS 10 system consists of a Smart Antenna (QC1000) located on the outer side the vehicle, an operator's interface (Display). The Smart Antenna contains all main sensors (GNSS engine, radio transceiver, micro-controller, memory, data interfaces and a series of sensors and other transmitters including networking capabilities such as Wi-Fi/LTE).

The QD1400 is an LCD Display providing the operator with a top view of the traffic situation as well as visual and acoustical warnings (sound patterns over loudspeakers) and other operational

or safety information in the form of symbols, icons and text. It provides both location and type of vehicle of nearby opponent vehicles. It features a touch display for operator input if required.

QD200 LED Display provides a directional information of nearby traffic and danger as well as for acoustical warnings (beeping over buzzer) and one button for input.

The Smart Antenna receives position and movement information from an internal high-sensitivity dual-band, multi-constellation GNSS module. Additional sensors and logic further enhance the accuracy of position measurements. The predicted driving path of the vehicle, in which the CAS 10 system is installed, is calculated and the obtained information is transmitted by radio as a low-power digital burst signal at frequent intervals. Provided they are within receiving range, these signals are received by other vehicles also equipped with CAS 10 or legacy CAS components. The incoming signal is compared with the driving path calculated and predicted for the second vehicle, taking into account configuration parameters like maximum acceleration or vehicle dimension.

If the CAS 10 system determines the risk of dangerous proximity to another vehicle (or to an obstacle equipped with the system), the unit gives the operator a warning of the greatest danger at that moment.

The operating range is very dependent upon the antenna installation in or outside the vehicle. The normal range is about 500m for standard operations, but up to 2 km may be achieved in individual cases. For their radio communication, CAS 10 system use a proprietary patent- and copyright-protected protocol.

3.4 Limitations of the System

CAS 10 system is not designed for use

- in deep or narrow open pit mines where availability of GNSS satellites is not sufficient
- in any other application than open pit mining
- on vehicles with excessive vibration

3.5 Legal Statement and Disclaimer







For their radio communication, CAS 10 system use a proprietary patent- and copyright-protected protocol. Any non-licensed use, dissemination, copying, implementation or reverse engineering of the CAS radio communication protocol, their hardware and software or parts of it is forbidden by law and will be prosecuted.

CAS 10 units are only to be used with other CAS 10 units in fleet and it is “over-the-air”-compatible with CAS 4.x units. Otherwise inconsistent function may occur. Hexagon cannot assume any liability from correct or incorrect use of above specified products other than regular warranty according to Hexagon General Terms and Condition.

4 Hardware Overview

4.1 Main Components and Accessories

Material SAP	Material Short Description	Picture	Details
902712	QC1000 HxGN MineDiscover Smart Antenna		Smart Antenna including Mount Module QL1212 for bracket mount.
902717	QD1400 HxGN MineDiscover Display 5		5" LCD Display with Touch Functionality
929039	QL1212 Through-Hole Mount Module Smart Antenna		Through-Hole mount module QC1000 Smart Antenna. Spare part only.
938190	QL1210 Mag Mount Smart Antenna		Magnetic mount module for Smart Antenna for attaching Smart Antenna on magnetic vehicle surfaces, typically on light vehicles.
896490	QM1105 Cable Smart Antenna 5m angled		M16-F (right-angled connector) to M16-M, 5m, PWR-SER-ETH-2xCAN-4xGPIO. Typically used for mast bracket mount on heavy vehicles.
906529	QM1106 Cable Smart Antenna 5m straight		M16-F (straight connector, to M16-M, 5m, PWR-SER-ETH-2xCAN-4xGPIO. Can be used as extension for QM1105.
916130	QM1107 Cable Smart Antenna 6m straight light		M16-F (straight) to M12-M, 6m, PWR-SER-ETH-3xGPIO; Typically used for LV with or without mag mounts.
921242	QM1108 Cable Smart Antenna 6m straight Visitor		M16-F (straight) to M12-M, 5m, PWR-SER-ETH; Typically used for Visitor Unit with mag mount.
916131	QM1110 Junction Harness Smart Antenna		Junction harness to branch out PWR-SER-ETH-2xCAN-4xGPIO from Cable Smart Antenna

916132	QM1111 Junction Harness Smart Antenna Light		Junction harness to branch out PWR-SER-ETH-3xGPIO from Cable Smart Antenna light; Typically used for LV and Visitor Unit
931480	QM1113 Cable, CAS 10 Ethernet Harness		Harness between Junction Harness, Ethernet Switch and Display 5
939550	QM1114 Cable, Ethernet M8-8F to M12-4M, 0.4m		Cable between Junction-Harness for secondary Smart Antenna (beacon) to Ethernet Switch
xxxxx8	QX1120 CAS 10 Ethernet Switch		
921244	QM1130 Cable Display 5 2.5m		M8-M (straight) to M8-F, 2.5m, PWR-ETH; Typically used for Smart Display
938004	QX1300 CAS 10 Battery Pack		Battery Pack with Power management for Visitor Unit
xxxxx1	L-Bracket, Smart Antenna	pending	Bracket to mount Smart Antenna on mast or rail
xxxxx2	RAM mount, Display 5	pending	RAM mount to mount Display 5 on dashboard (including arm, top and bottom flange) with screws to Display and dashboard
xxxxx3	QN1999 CAS 10 Vehicles Installation Kit	pending	Installation kit for CAS 10, suits all vehicles, contains standard screws, cable ties, DEUTSCH PWR connector, flying leads
xxxxx4	RAM Mount, Suction mount assy for visitor unit	pending	RAM mount with suction mount for temporary installation of QD1400 Display 5 on non-porous, plain surfaces. Includes screws for attachment to QD1400.
xxxxx5	Classy suitcase for visitor unit	pending	Robust suitcase with organized inlay for all Visitor Unit items. Fits QN1910 and QN1911 with QD200
xxxxx6	Mast Assembly	pending	

5 QC1000 HxGN MineDiscover Smart Antenna

5.1 Electrical Specifications

Parameter	Range	Note
Input power nominal	9-36VDC	
Power consumption at 12V nominal	350 mA	
Interfaces	1x ETH, 2x CAN, 4x GPIO, 1x RS-232	For Ethernet, see par 5.6
GNSS	Multi-band GNSS module with integrated multi-band RTK, allowing for 4 concurrent constellations	
RF	868/902-928 MHz	4 Hz refresh rate. See also par 5.4
UWB ToF	integrated	See par 5.5
Wi-Fi	802.11 b/g/n 2.4GHz, WPA2	Only the 2400 ... 2483.5 [MHz] band is active. See par 5.7
Cellular	3G, 4G/LTE	See par 5.8
IMU	9-axis on-board: Accelerometer / Gyroscope/ Magnetometer	
Other sensors (MEMS)	Pressure, humidity, temperature, ambient light	
Data Storage / Memory	4GB SD-card	To store logfiles, settings and configuration
GPIOs	4 General Purpose Input and Output	To interact with actuators or sensors outside the device. See par 5.14

5.2 Mechanical Specifications

Parameter	Range	Note
Diameter	Ø 169 mm (6.65 inch)	
Height	105 mm (4.1 inch)	
Weight	980 g	
Housing material	Polycarbonate (white)/Aluminum Alloy (black)	Including Hexagon branding
Status LED	Multi-color	See par 5.11

5.3 Environmental Specifications

Parameter	Range	Note
Storage Temperature	-40 to 85°C	
Operation Temperature	-20 to 70°C	
IEC 60529 Ingress Protection	IP69K/IP67	with connected cable or protection cap on connector
Flammability	UL94 / IEC 60695-2-12	

5.4 ISM Radio Specifications

The ISM radio is for vehicle to vehicle communication. Depending on the region different bands are in use.

Region	Band (MHz)	Max. output power
EU	868.2	14 [dBm]
South Africa		
USA	902.4 ... 922 with frequency hopping	17 [dBm]
Canada		

Which frequency to use, and with the corresponding bandwidth, is a configuration parameter that customers select at installation, and must be based on country specific regulations.

5.5 UWB ToF Radio Specifications

There is an on-board UWB ToF Radio inside the Smart Antenna.

Region	Band [MHz]	Center Frequency [MHz]	Bandwidth [MHz]	Max. output power
EU	3328 ... 4659.2	3993.6	1331.2	- 41.3dBm
South Africa	3328 ... 4659.2	3993.6	1331.2	
USA	5948.8 ... 7030.4	6489.6	1081.6	
Canada	5948.8 ... 7030.4	6489.6	1081.6	

5.6 Ethernet

It is possible to connect the QC1000 unit to the LAN of the vehicle. The unit communicates either with 10Base-T or 100Base-T and is able to act as DHCP, if necessary. Furthermore, the device can route the local Ethernet to the WLAN or to the LTE.

5.7 Wi-Fi

Frequency	Band	Max. Output Power
2412 MHz to 2462 MHz	802.11b/g	15dBm
	802.11n	14dBm

5.8 LTE

The LTE module acts as an alternative to the WLAN.

The module supports the following bands:

- LTE FDD: B1/B2/B3/B4/B5/B7/B8/B12/B13/B18/B19/B20/B25/B26/B28
- LTE TDD: B38/B39/B40/B41

With a maximal output power of 23 ± 2 [dBm].

In case of using the 902-922 [MHz] band for ISM radio, the BAND-8 of the LTE module is disabled due to overlapping of frequencies.

5.9 Connector Description

QC1000 features a M16-19p male connector compatible to cables:

- QM1105 Cable Smart Antenna 5m angled
- QM1106 Cable Smart Antenna 5m straight
- QM1107 Cable Smart Antenna 6m straight light
- QM1108 Cable Smart Antenna 6m straight Visitor

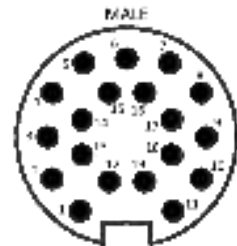

Pin	Name	Description
1	Batt +	Positive power-supply for the unit
2	CAN1-L	Low level CAN bus input/output line → for the communication with Radars / PA ... → the same signal as on Pin 19
3	Serial-GND	Reference voltage for the serial communication RS232
4	GPIO-1	Digital Input and Output Analog Input
5	ETH-RX+	Ethernet Receive / Transmit positive channel 2
6	ETH-TX+	Ethernet Transmit / Receive positive channel 1
7	GPIO-3	Digital Input and Output
8	GPIO-2	Digital Input and Output
9	CAN2-L	Low level CAN bus input/output line → dedicated CAN for VIS
10	GPIO-0	Digital Input and Output Analog Input
11	GND	Negative power-supply for the unit
12	CAN1-H	High level CAN bus input/output line → for the communication with Radars / PA ... → the same signal as on Pin 18
13	Serial-RX	Receive input for the serial communication RS232
14	Serial-TX	Transmit output input for the serial communication RS232
15	ETH-RX-	Ethernet Receive / Transmit negative channel 2
16	ETH-TX-	Ethernet Transmit / Receive negative channel 1
17	CAN2-L	High level CAN bus input/output line → dedicated CAN for VIS
18	CAN1-H	High level CAN bus input/output line → for the communication with Radars / PA ... → the same signal as on Pin 12
19	CAN1-L	Low level CAN bus input/output line → for the communication with Radars / PA ... → the same signal as on Pin 2

5.10 Face plate/Label Description

A label is placed at the lower side of the QC1000 indicating Model, Article Number, Manufacturer and compliance statements. Label is white print on black background.



5.11 User Interface – LED bar

At the front of the Smart Antenna, there is a light bar backed with high-brightness LEDs. LED bar provides indications on system status. The LED bar provides system status during installation as well as during operations.



Condition	LED color	LED intensity	LED timing	Comment
Bootloader started	RED	Max intensity	Constant on	For errors like no valid firmware found.
Bootloader error	RED	Max intensity	Double blink	This is when there is a permanent error during start-up, such as an unsupported CPU detected.
QC1000 running - OK	GREEN	Based on ambient light	Short blink every 5s	Shown in normal operation if no error is present.
QC1000 running - ERROR	RED	Based on ambient light	Short blink every 2s	
QC1000 running - IDENTIFICATION	RED /ORANGE/ GREEN	Based on ambient light	Blink each color for a couple of times.	Identification is a request from an external tool. The intent is to make a visible indication on a selected QC1000, so that it can be distinguished from other QC1000s on

				the same vehicle. After identification mode, LED bar indication reverts back to the correct indication based on status.
--	--	--	--	---

5.12 Network Capabilities

pending

5.13 SIM Card and eSIM capabilities

SIM card form factor: nano

Installation of SIM card has to be done by qualified workshop.

5.14 General Purpose Input Outputs (GPIOs)

A versatile scheme of relaying environmental information from and to the QC1000 unit is available through the GPIOs.

Item	Min	Typical	Max	Unit
GPIO input voltage to GND (digital & analog)	0		+Batt	V
GPIO high output voltage to GND	+Batt -1.5	+Batt -0.5	+Batt	V
GPIO low output voltage to GND	0	0.5	1.5	V
GPIO output current to GND	-0.4		0.4	A

The maximum voltages indicated must be met at all times or irreversible damage to the equipment might be the result.

Due to the multi-purpose nature of the GPIO, it's not possible to galvanically isolate them. If galvanic isolation is required install a protection relay in the signal path.

Important Considerations

Furthermore, always connect inputs/outputs to non-sensible systems. Since QC1000 is permanently powered, it must be made sure it can never feed current into a potentially dangerous subsystem even if the connection of either one of the power supply lines (either Vbatt+ or Vbatt-) are lost.

5.14.1 Example Installation Reverse Switch

Always connect the reverse gear sense line to the switch side, which connects to the buzzer or the strobe for reversing. **Never connect on the relay coil side or on a driving output!**

It is compulsory to mount protection relays when the inner workings of signal sources are not completely understood or the receiving subsystem might act unexpectedly.

The following schematic shows the recommended connection to the reverse switch signal in a vehicle with negative isolation switch (as found in Caterpillar, Komatsu and alike).

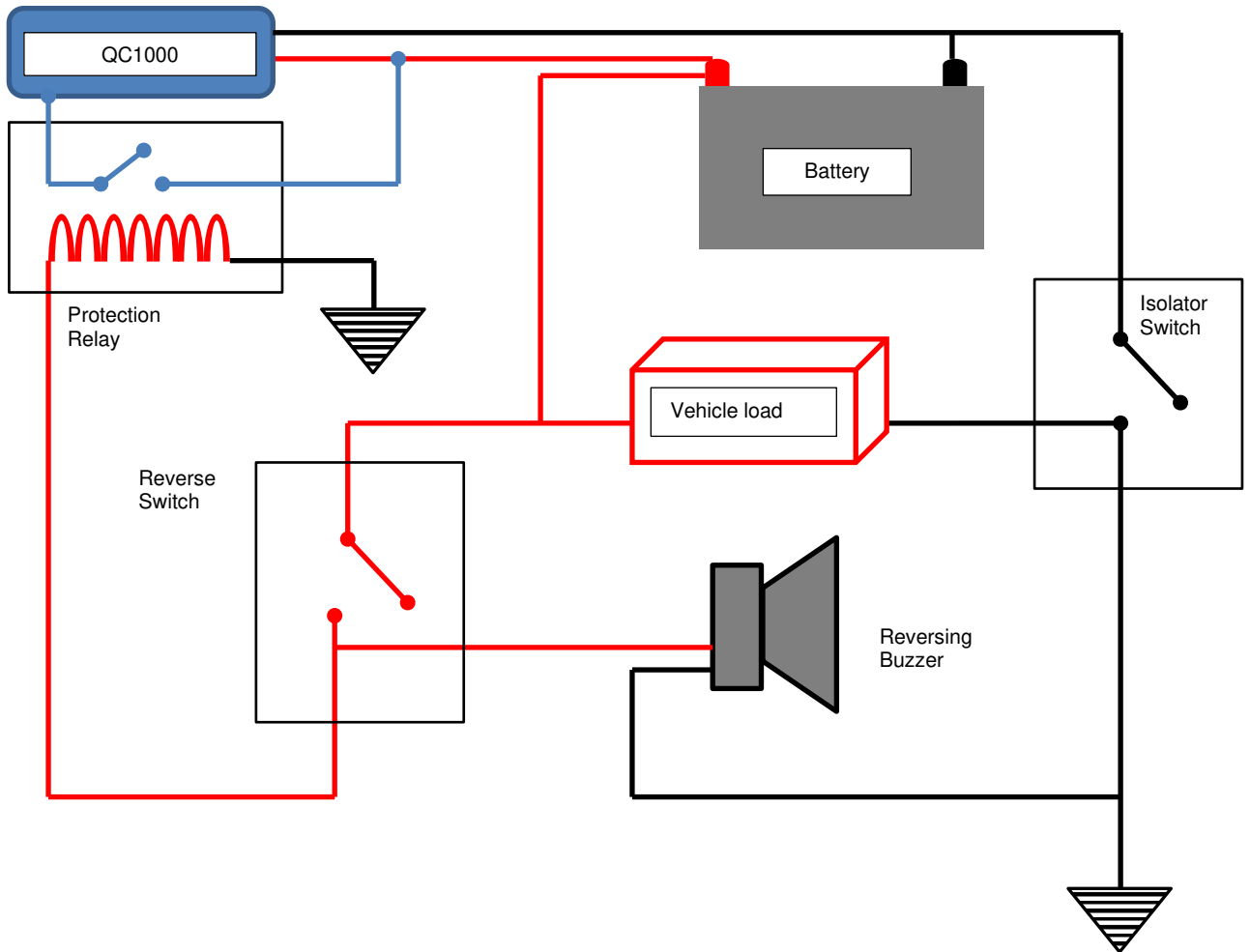

This configuration prevents eventual currents flowing from the QC1000 reverse input to the vehicle systems when the isolator switch is opened or the negative connection of the CAS should become disconnected.

5.15 Power Save Mode

The system is designed such that it won't drain vehicle battery to the point where vehicle wouldn't start anymore.

Also, a low power mode kicks in when a vehicle is detected to be in stand-still for more than 10 minutes by its GNSS location and vehicle motor is detected to be off.

5.16 Installation of QC1000

5.16.1 Installation of QC1000 with bracket

Hexagon recommends the installation of QC1000 on a bracket for all permanent installation for its superior stability even in heavy vibration.

QC1000 has 3 thread insert for M8 screws to be fixed on a corresponding hole pattern of a bracket.

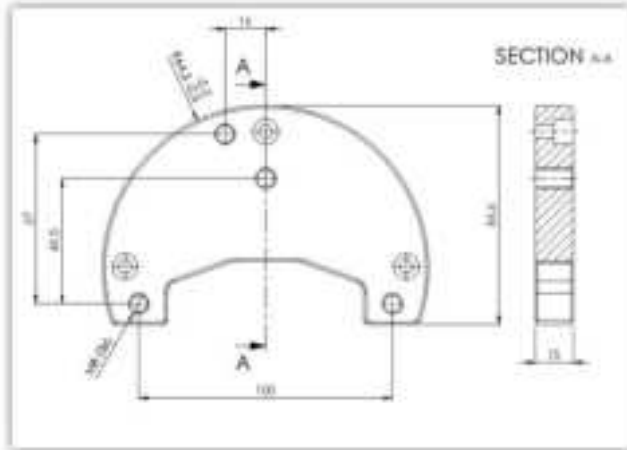

QL1212 Through-Hole Mount Module Smart Antenna

5.16.2 Installation of QC1000 with magnetic mount



QL1210 Mag Mount Smart Antenna

QC1000 provides an optionally the QL1210 Mag Mount Smart Antenna. Replace the through-hole mount module with QL1210 Mag Mount using the same screws.

QL1210 is fitted with very strong magnets. This magnetic base attaches to any reasonably magnetic material. It allows an easy installation on vehicle roof tops and is ideal for light or other vehicles with moderate vibration.

Attention: Magnets can fly together or on to steel objects causing severe pinching or lacerations to the skin. Keep strong magnets away from head, eyes, heart, and trunk.

5.17 Compliance

5.17.1 CE – Declaration of conformity

Hereby, Hexagon Geosystems Services AG, declares that the radio equipment type QC1000 is in compliance with Directive 2014/53/EU and other applicable European Directives. To receive a copy of the latest Declaration of Conformity (DoC) for the product, either contact your local sales representative or contact us via <http://hexagonmining.com/customer/portallogin>.

5.17.2 FCC compliance statement

This device complies with part 15 of the FCC Rules. Operation is subject to the following two conditions:

1. This device may not cause harmful interference, and
2. This device must accept any interference received, including interference that may cause undesired operation.

Note: This equipment has been tested and found to comply with the limits for a Class A digital device, pursuant to part 15 of the FCC Rules. These limits are designed to provide reasonable protection against harmful interference when the equipment is operated in a commercial environment. This equipment generates, uses, and can radiate radio frequency energy and, if not installed and used in accordance with the instruction manual, may cause harmful interference to radio communications. Operation of this equipment in a residential area is likely to cause harmful interference in which case the user will be required to correct the interference at his own expense.

The user shall be cautioned that changes modifications not approved by the responsible party could void the user's authority to operate the equipment.

5.17.3 ISED Canada compliance statement

This device complies with ISED Canada license-exempt RSS standard(s). Operation is subject to the following two conditions: (1) this device may not cause interference, and (2) this device must accept any interference, including interference that may cause undesired operation of the device.

Le présent appareil est conforme aux CNR d'ISDE Canada applicables aux appareils radio exempts de licence. L'exploitation est autorisée aux deux conditions suivantes : (1) l'appareil ne doit pas produire de brouillage, et (2) l'appareil doit accepter tout brouillage radioélectrique subi, même si le brouillage est susceptible d'en compromettre le fonctionnement.

5.17.4 RF Exposure

RF Radiation Hazard Warning

To ensure compliance with FCC and Industry Canada RF exposure requirements, this device must be installed in a location where the antennas of the device will have a minimum distance of at least 20 cm from all persons. Using higher gain antennas and types of antennas not certified for use with this product is not allowed. The device shall not be co-located with another transmitter. Installez l'appareil en veillant à conserver une distance d'au moins 20 cm entre les éléments rayonnants et les personnes. Cet avertissement de sécurité est conforme aux limites d'exposition définies par la norme CNR-102 at relative aux fréquences radio.

5.17.5 Disposal of Product

Improperly dispose of product:

If the product is improperly disposed, you may enable unauthorized persons to use it in contravention of the regulations, exposing themselves and third parties to the risk of severe injury and rendering the environment liable to contamination.

Precautions:

The product must not be disposed with household waste. Dispose of the product appropriately in accordance with the national regulations in force in your country. Always prevent access to the product by unauthorized personnel.



5.17.6 Approved Countries

Please refer to Approved country list.

6 Displays

To convey information for collision avoidance and traffic awareness as well as other system and operational information to the user, a UI/UX interface must be installed. The CAS 10 solution provides two options to choose from:

- QD1400 HxGN MineDiscover Display 5 (standard)
- QD200 Remote Display (optional)

6.1 QD1400 HxGN MineDiscover Display 5

Display 5 features a high-resolution LCD Display with Touch Functionality with high volume speakers for use in heavy machinery (adjustable) and automatic brightness adjustment for day and night operation as well as a fingerprint sensor.



6.2 QD200 Remote Display



The QD200 Remote Display offers the following attributes:

- Indication of surrounding vehicles through 12 dual color LEDs (red/green) in a circle
- Status Indication through 4 dual color LEDs (red/green): Power, GPS, Reverse and Mode
- Multifunction push-button
- Piezoelectric buzzer
- Ambient light sensor

The maximum length of the display cable is 15m. This can be achieved by connecting several display extension cables together.

The LED brightness is automatically controlled based on ambient light, in order to provide dimming for night operation.

The buzzer, with a maximum volume of 85dB (at 10cm distance), can be automatically controlled based on ambient noise.

The image shows a display while the device is operating in a vehicle, traveling forward ('Reverse LED', second from top, is OFF) and a vehicle (equipped with another Hexagon CAS device) is detected. The LED on in the 12 o'clock position indicates the presence of a vehicle in front. Several colors and sounds indicate different threat levels. Depending on the distance to other vehicles and on the configuration parameters an alarm might be audible. The center compass displays direction and distance of vehicles within the RF transmitter / receiver range but it also serves to display error codes in the case a system failure was detected.



The LEDs on the left side of the display show the status of the system. They indicate if the device has enough power, has acceptable GNSS reception or is traveling backwards as well as other information about the system.

Depending on the configuration, pushing the square button on the right of the display can trigger three functions:

1. Flag special events in the unit's log-file: for example an incident or a situation where the user believes the system didn't perform as expected.
2. Acknowledge an alarm: The operator can stop the warning sound for example when being towed by another vehicle.
3. Pressing the button for 3 seconds or longer seconds will restart the QC1000 Smart Antenna.

All alarms are indicated during a minimum of 1.5 seconds to allow the operator to see and react to it. The alarm will stop once the threat is gone or if one of the two vehicles stops.

6.3 Installation of Displays

- The display should be positioned such that the front panel is in direct view of the Operator, the acoustic warning tone can be heard loud and clearly and control button/touch display can be operated easily.
- The view on the front panel may not be obstructed at any time.
- The display may never interfere with the operation of the vehicle (incl. emergency procedures)
- **Special attention is required to not reduce the operator's field of view.**

6.4 Installation of QD200 Remote Display

- The QD200 Remote Display has a male M8 type connector with 4 contacts. It connects to the QD221 and QD222 extension cables.
- The back side of the display's aluminum housing includes two 8mm deep M4 blind threads, so that the housing can easily be secured. Forcing screws longer than 8 mm into the nuts may cause damage and voids warranty.
- The remote display is light enough to be fixed with 3M dual lock. This is ideal for installations where the owner of the vehicle does not permit to drill holes in the dashboard.

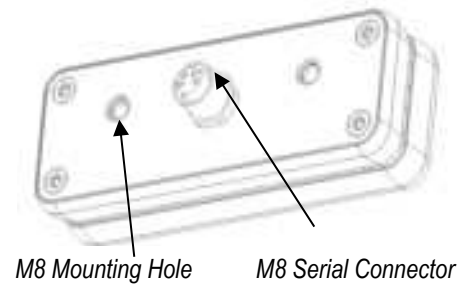

7 System Installation

7.1 General Rules and Best Practices

Please check on the following conditions before beginning any work. Differing installations will void the warranty of Hexagon MineProtect systems:

- Installations may only be carried out by trained electricians.
- Only antennas supplied by Hexagon may be used.

Unless certified, installation and operation of HxGN MineProtect systems must be on the basis of non-interference with existing equipment. When certified, installation and operation must be done according to certification procedures in order to comply with official regulations and requirements.

Never connect Hexagon equipment to critical vehicle signal lines without prior consultation and approval of the vehicle manufacturer and Hexagon's approval.

Connecting the reverse signal to the CAS unit is compulsory in all vehicles that provide such signal. But rather than connecting to critical signal lines use the connection to noncritical signals such as reverse light, reverse buzzer and similar.

After installation, an appropriate entry should be made in the vehicle's technical logs including QC1000 serial number and the installed firmware version. A check should be performed in order to reinsure the installation's quality and its accordance with the requirements. Special focus has to be given that the mechanical or electrical performance of other vehicle's systems (e.g. radio) is not influenced by the CAS system.

Hexagon highly recommends establishing a "Radio Map", containing all intentional transmitters present on the mine and their respective operating frequencies. This map will help identifying potential collisions between frequency ranges and avoid radio interference.

7.1.1 Installation

- The selected installation spot **must** be dry and reasonably free from dust.
- Install all components so that it does not interfere with any of the vehicles operations.
- A good installation spot provides enough space for the cables and their connectors.
- The mount surface should be flat in order to avoid mechanical stresses on the housing of the QC1000
- The power cable **needs** to be connected directly to the battery contacts, bypassing the ignition and the isolation switch. This is to ensure the CAS system keeps working even when the vehicle is switched off or being serviced.
- Fuses is **required** in the power connection for **both** power and ground according to system diagrams.
- **Do not bend any cable** further than its minimum bending radius.
- Cables need to be long enough to avoid tension. If the installed cable is under tension, relocate the units or reroute the cable. If neither is possible replace the cable by a longer one or use extension cables.
- Install the cables in a way (cable ties) allowing easy service and removal. Do not route them over or under access doors or removable plates



7.1.2 Connection to Battery

pending

7.2 Light Vehicles

7.2.1 System Diagram

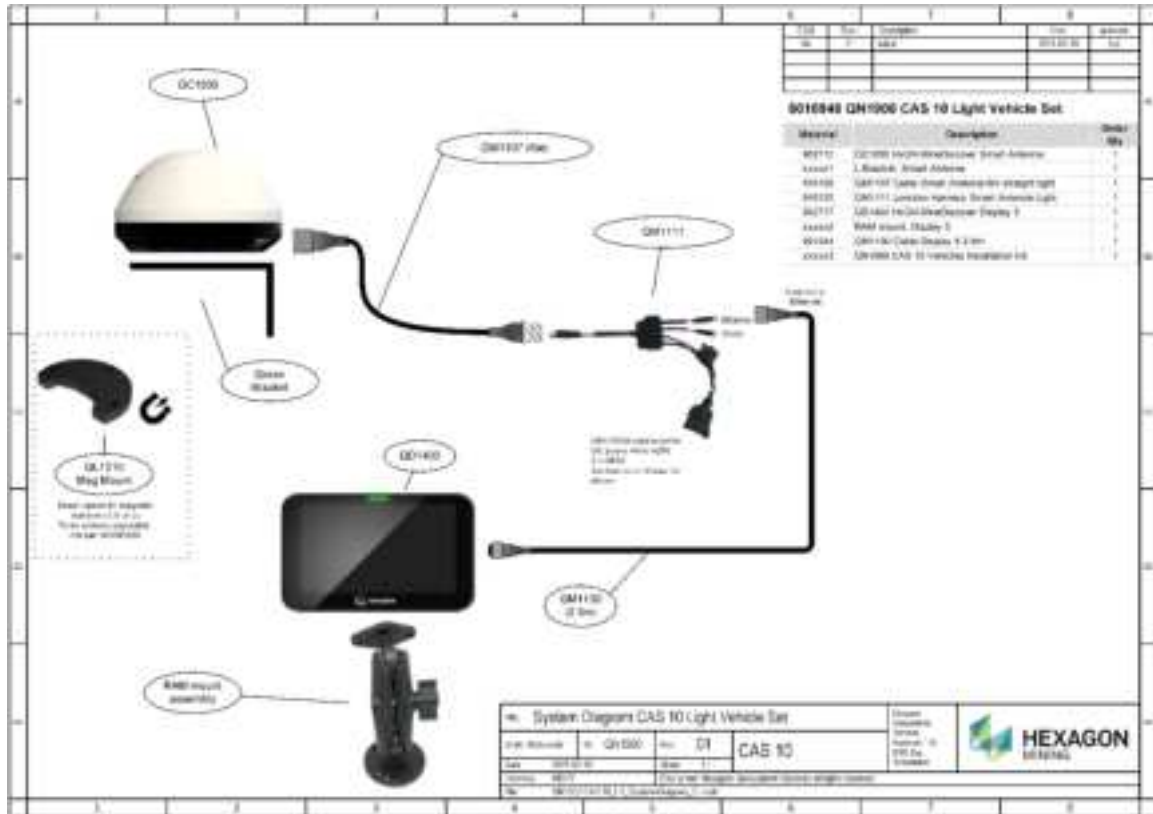

7.3 Visitor Unit

7.3.1 System Diagram

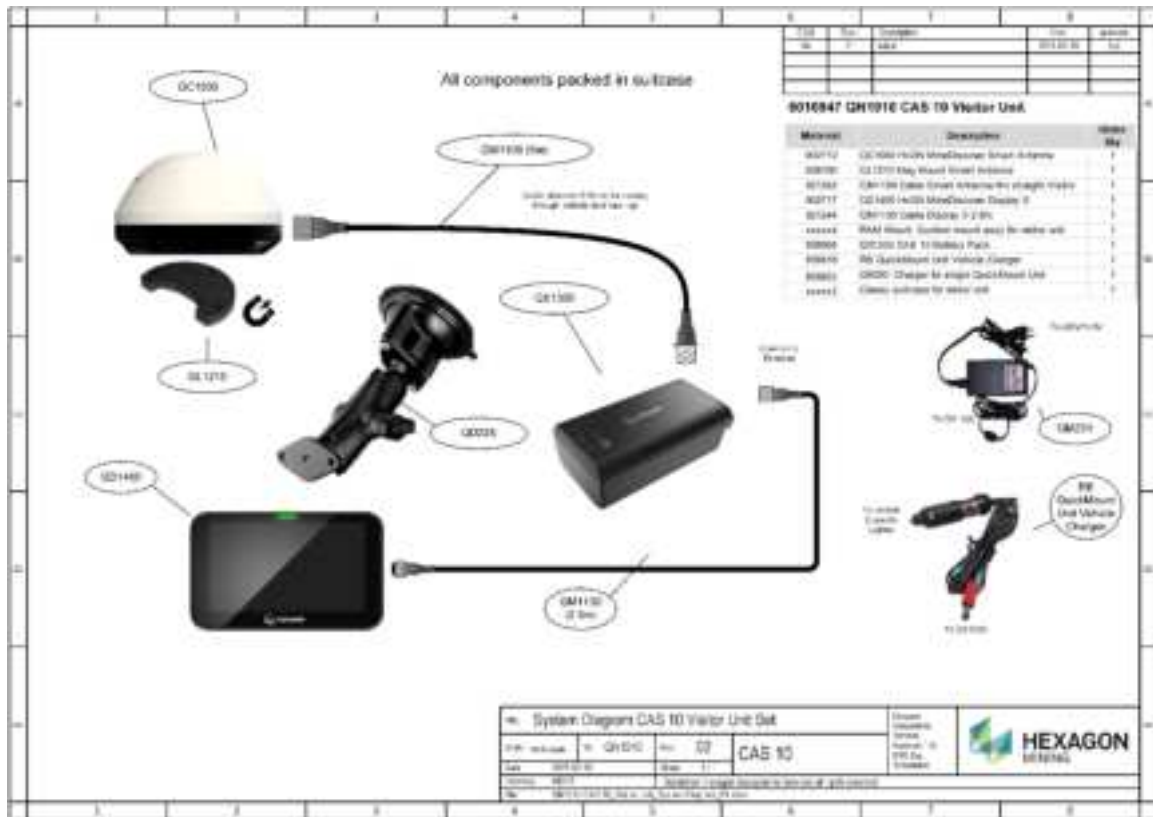

7.3.2 System Diagram with QD200



7.4 Haul Trucks

7.4.1 System Diagram

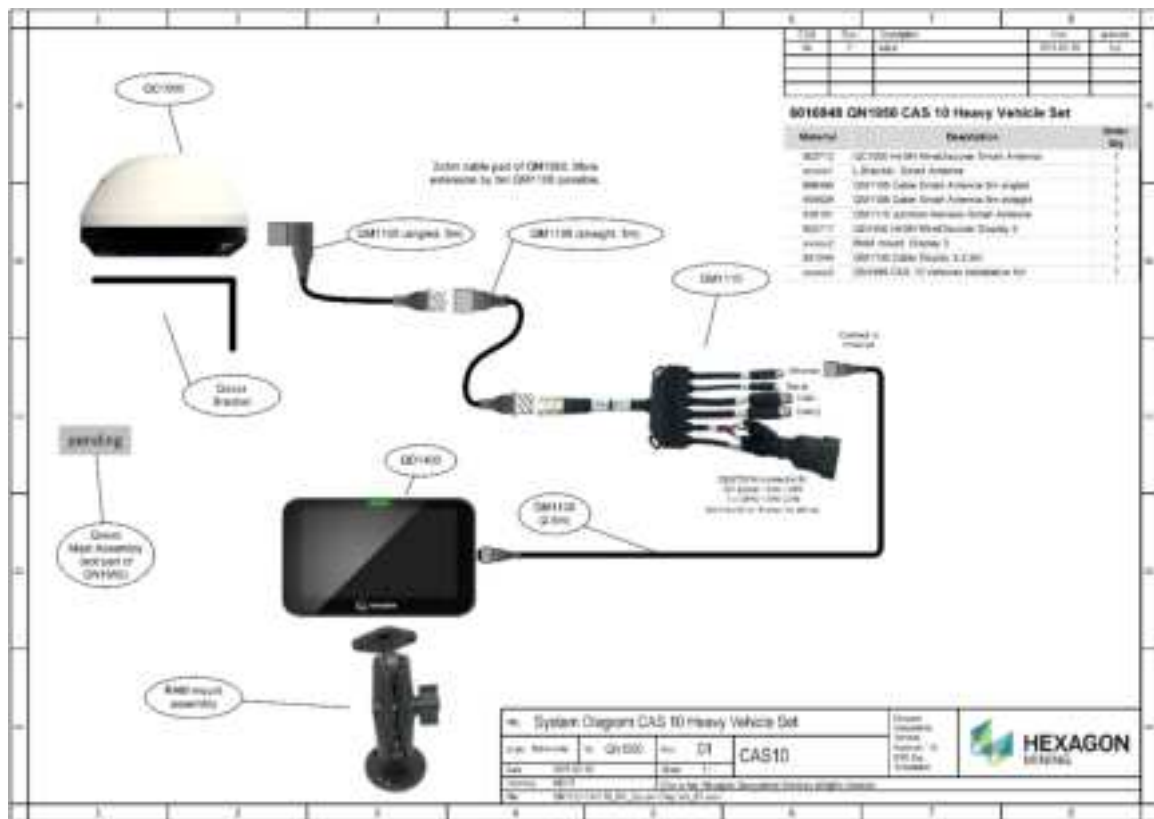

7.4.2 QC1000 Location

It is not always possible to position the QC1000 on the topmost location. On haul trucks the bucket might be covering the entire structure of the vehicle and thus making the installation of an QC1000 on the top rather impractical. In this case Hexagon recommends using a pole on which the QC1000 can be mounted. The best position for QC1000 is one of the front corners. If the vehicles transit on the right side of the road than the left corner is most appropriate and vice versa. The pictures below show different configurations for pole sizes and positions.

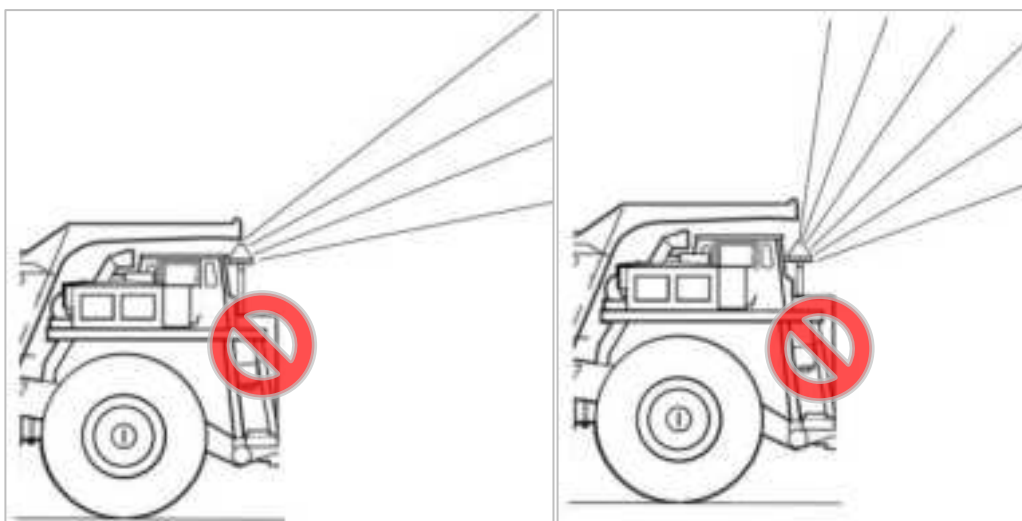

The QC1000 positions in the above drawings are to be avoided:

- *THE LEFT PICTURE SHOWS AN ANTENNA DIRECTLY UNDER THE CANOPY. THE ANTENNA'S RECEPTION IS VERY BAD.*
- *IN THE RIGHT PICTURE THE ANTENNA IS POSITIONED LOWER BUT STILL HAS BAD RECEPTION DUE TO BEING UNDER THE CANOPY.*

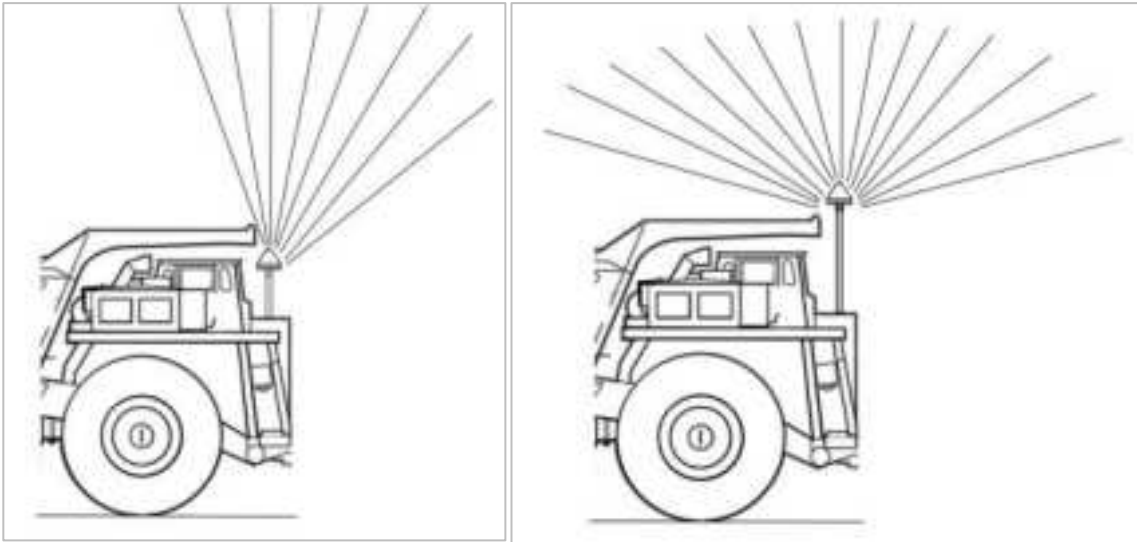

QC1000 positions in the above drawings improve from left to right:

- *THE THIRD PICTURE SHOWS AN ACCEPTABLE POSITION. THE ANTENNA IS NOT COVERED BY THE CANOPY AND IS AT LEAST 1M FROM ANY METAL STRUCTURE SUCH AS THE CANOPY, THE HANDRAIL OR THE CABIN PLATFORM.*
- *THE FOURTH PICTURE ON THE RIGHT EXTREME SHOWS THE ANTENNA'S RECOMMENDED IDEAL POSITION.*

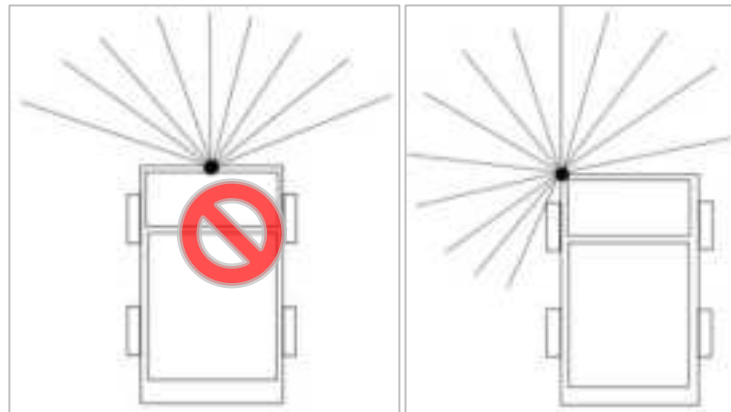

Antenna position with regard to the vehicle body in the top views:

- *THE LEFT PICTURE SHOWS HOW THE CANOPY SHIELDS A CONSIDERABLE PART OF THE GPS AND RF.*
- *THIS IS WHY THE RIGHT PICTURE IS HEXAGON'S RECOMMENDED POSITION.*

7.5 Tracked Vehicles

On tracked vehicles, the antenna must be mounted as close as possible to the axis of rotation. For better accuracy, especially to sense a turning maneuver on the spot without losing heading, is to apply the two-antenna configuration.



Beacon Antenna

For vehicles that operate in regions of the mine where more than 30% of the view of the sky is obstructed, this distance between main and beacon QC1000 shall be increased to 15 meters.

It is essential that both antennas are not obstructed by any part of the vehicle and have a 360° view of the horizon (except for terrain obfuscation).

Limitation

The center of rotation is assumed to be in the middle of the vehicle for the rotation prediction. If there is a significant difference between the true axis of rotation and the center a slight positional error will result.

7.7 Pre-Configuration

After mechanical installation and correct cabling, QC1000 must be pre-configured to connect to the MPData Server. Once this pre-configuration is correctly done, QC1000 can be updated remotely via the server and network.

7.8 Installation Verification

After installation, perform installation verification procedure as per below:

DATE:	VEHICLE MODEL:
SITE:	VEHICLE ID:
TECHNICIAN:	DISPLAY:
ANTENNA: QC1000	QC1000 SERIAL NO:
CONFIG FILE RECEIVED FROM:	

MAIN DEVICE	PARAMETERS	YES	NO	COMMENT
	INSULATED FROM GROUND			
	TWO 2 AMP FUSES ON POWER CABLE			

	CONFIG FILE UPLOADED			
QC1000	FULL VIEW OF SKY			
	INSULATION WASHER			
	GROUND PLANE LARGER THAN ANTENNA			
	MOUNTED AS OTHER IDENTICAL MODELS			
ANTENNA CABLES				
	BENDING RADIUS IS 5CM OR BIGGER			
	CONNECTORS AREN'T TOUCHING AN METAL			

UNEXPECTED EVENTS:

SIGNATURE: _____

7.9 Maintenance Checklist

To be performed before vehicle is released

Item		
Date checked		
Responsible		
Configuration technician		
QC1000 serial number		
Firmware version loaded		
Display type		
Vehicle Plant number		
	Initial	Comment
Check cables, abrasion, UV damage		
Visual inspection of housing for damage		
Firmware updated to latest version		
Buzzer/speaker unobstructed and working		
Ready LED-bar green after <3 minutes (if vehicle is outside)		

8 Troubleshooting

8.1 Error Codes

pending

Appendix E: Legal statement

WARNING OF PERSONAL INJURY

As with all traffic awareness, collision avoidance and personal alert devices, Hexagon Mining products may not detect all threats within the detection window. Hexagon Mining products are intended as an additional tool in determining potential traffic threats, supporting an alert and conscientious driver. Hexagon Mining products are not designed as a substitute for proper safe driving and visual traffic scanning procedures; a vigilant effective lookout is required at all times. Hexagon Mining products only warn the operator of the presence of other vehicles and personnel that are also fitted with Hexagon Mining products or warn of obstacles that are stored in the internal database. Hexagon Mining products do not substituted for an experienced and alert operator. The operator of the vehicle remains fully responsible for operating the vehicle and ensuring the safety of passengers, pedestrians and other traffic. Never use Hexagon Mining products for applications other than their intended and authorized use. Before installing, handling, using or servicing Hexagon Mining products, consult the data sheet, manuals and application notes and make yourself thoroughly familiar with the operations and limitations. Failure to comply with these instructions could result in serious injury or death.

HexagonHexagonHexagonHexagonHexagonHexagonHexagonHexagonHexagon.

LIMITED WARRANTY

EXCEPT FOR THE WARRANTIES EXPRESSLY SET FORTH HEREIN, HEXAGON MAKES NO WARRANTIES, EITHER EXPRESS OR IMPLIED, WITH RESPECT TO THE PRODUCT. ANY AND ALL WARRANTIES, INCLUDING WITHOUT LIMITATION, WARRANTIES OF MERCHANTABILITY OR FITNESS FOR A PARTICULAR PURPOSE, ARE EXPRESSLY EXCLUDED AND DECLINED. HEXAGON is only liable for defects of this product arising under the conditions of operation provided for in the data sheet and proper use of the goods. HEXAGON explicitly disclaims all warranties, express or implied, for any period during which the goods are operated or stored not in accordance with the data sheet. The warranty voids in the case of the following cases: any opening of the housing, inappropriate operations or installation (see the restrictions in the respective manuals) and intellectual property violations.

Hexagon Ltd.'s entire liability and customer's exclusive remedy for Hexagon products that fail to conform to Hexagon Ltd.'s limited warranty, shall be, at Hexagon Ltd.'s sole option, either repair or replacement of the nonconforming products, or, if neither is practicable, a refund of the fees paid by customer to Hexagon Ltd. for such products. The warranty for the repaired or replaced product is limited to the scope and remaining duration of the original warranty for the nonconforming product.

LIMITED LIABILITY

Hexagon Ltd. does not accept any liability arising out of any application or use of any product or circuit and specifically disclaims any and all liability, including without limitation consequential or incidental damages. All operating parameters, including without limitation recommended parameters, must be validated for each customer's applications by customer's technical experts. Recommended parameters can and do vary in different applications. HEXAGON LTD.'S LIABILITY TO CUSTOMER ARISING OUT OF OR RELATING TO ANY HEXAGON PRODUCTS SHALL NOT EXCEED THE AGGREGATE AMOUNTS PAID BY CUSTOMER TO HEXAGON FOR SUCH HEXAGON PRODUCTS. IN NO EVENT WILL HEXAGON LTD. BE LIABLE FOR LOST USE, PROFITS, REVENUE, COST OF PROCUREMENT OF SUBSTITUTE GOODS, OR ANY OTHER SPECIAL, INDIRECT, RELIANCE, INCIDENTAL, OR CONSEQUENTIAL DAMAGES, HOWEVER CAUSED AND UNDER ANY THEORY OF LIABILITY RELATING HERETO. Radio band frequency allocation and licensing conditions may vary from country to country. The operator is solely responsible for ensuring that Hexagon products are operated in conformity with the applicable telecommunication laws.

If the customers uses Hexagon products for any unintended or unauthorized application, the customer shall defend, indemnify and hold harmless Hexagon Ltd. and its officers, employees, subsidiaries, affiliates and distributors against all claims, costs, damages and expenses, and reasonable attorney fees arising out of, directly or indirectly, any claim of personal injury or death associated with such unintended or unauthorized use, even if Hexagon Ltd. shall be allegedly negligent with respect to the design or the manufacture of the product.

INDEMNIFICATION

Customers agree to indemnify and hold harmless Hexagon Ltd., its subsidiaries, and affiliates, and their respective successors and assigns, from and against all third party claims, loss, damage or expense, and any other liabilities whatsoever, including without limitation, reasonable counsel fees, arising from or by reason of any actual or claimed damages, and/or injuries, or any litigation based thereon, which may be incurred by Hexagon Ltd. with respect to any of the Hexagon products covered by the order, including use, and such obligation shall survive acceptance of the Hexagon products and payment therefore by the customer.

INFRINGEMENT

Hexagon Ltd. does not warrant that products and its use will not infringe any patent, copyright or trademark. No specification shall constitute a warranty, express or implied, against any claims for infringement of patents, copyrights or trademarks. Customer shall indemnify and hold Hexagon Ltd., its subsidiaries and affiliates, and their respective successors and assigns, and its customers harmless from any and all third party liability for such infringement, including without limitation damages, costs, expenses (including reasonable counsel fees), and lost profits arising from any claim that the use of any goods supplied under the invoice infringe any patent, copyright or trademark rights.

9 Glossary

Term	Definition
AP	Access Point
CAS	Collision Avoidance System
FMS	Fleet Management System
GNSS	Global Navigation Satellite System
GPS	Global Positioning System
HP	High Precision
IP	Internet Protocol
LP	Low Precision
MAC	Media Access Control
RTK	Real Time Kinematic
SOPs	Standard Operating Procedures



About Hexagon Mining

Hexagon is a global leader in sensor, software and autonomous solutions. We are putting data to work to boost efficiency, productivity, and quality across industrial, manufacturing, infrastructure, safety, and mobility applications.

Our technologies are shaping urban and production ecosystems to become increasingly connected and autonomous — ensuring a scalable, sustainable future.

Hexagon's Mining division solves surface and underground mine challenges with proven technologies for planning, operations and safety.

Learn more at hexagon.com and follow us @HexagonAB.

Visit us at hexagonmining.com

