



Start-Up, Operation, and Maintenance Instructions

CONTENTS

	Page
SAFETY CONSIDERATIONS	2
INTRODUCTION	3
ABBREVIATIONS AND EXPLANATIONS	4
CHILLER FAMILIARIZATION (FIG. 1 AND 2)	4
Chiller Information Nameplate	4
System Components	4
Evaporator	4
Condenser	4
Economizer	4
Motor-Compressor	4
Purge Unit	4
Variable Frequency Drive (VFD)	4
Refrigerant Lubrication System	4
Chiller Control Panel	4
Purge Control Panel	5
PIC6 Touch Screen HMI	5
REFRIGERATION CYCLE	9
REFRIGERANT LUBRICATION CYCLE	10
Summary	10
Bearings	10
Inhibitor Reclaim System	11
Motor Cooling System	11
VFD Cooling System	11
VFD	11
Purge System	13
CONTROLS	15
Definitions	15
General	15
PIC6 System Components	16
START-UP/SHUTDOWN/RECYCLE SEQUENCE ..	16
Local Start/Stop Control	16
Lubrication Control	17
Shutdown	18
BEFORE INITIAL START-UP	19
Job Data Required	19
Equipment Required	19
Remove Shipping Packaging	19
Tighten All Gasketed Joints	19
Check Chiller Tightness	19
Refrigerant Tracer	22
Leak Test Chiller	22
Standing Vacuum Test	22
Check the Installation	24
Inspect Wiring	24
Chiller Dehydration	24
Inspect Water Piping	25
Check Safety Valves	25
Check Purge Compressor Operation	25
Ground Fault Troubleshooting	26
Carrier Comfort Network Interface	26
Inhibitor Charge	27
Software Configuration	28
Charge Unit with Refrigerant	28
Field Set Up and Verification	35
Perform a Controls Test (Quick Calibration/Quick Test)	35
INITIAL START-UP	36
Preparation	36
Check Motor Rotation	36
Check Refrigerant Lube Assembly	37
To Prevent Accidental Start-Up	37
Check Chiller Operating Condition	37
Instruct the Customer Operator(s)	37
OPERATING INSTRUCTIONS	40
Operator Duties	40
Prepare the Chiller for Start-Up	40
To Start the Chiller	40
Check the Running System	40
To Stop the Chiller	40
After Limited Shutdown	40
After Extended Shutdown	40
Cold Weather Operation	41
Manual Guide Vane Operation	41
Refrigeration and Service Log	41
PUMPOUT AND REFRIGERANT TRANSFER PROCEDURES	43
Preparation	43
GENERAL MAINTENANCE	46
Refrigerant Properties	46
Adding Refrigerant	46
Adjusting the Refrigerant Charge	46
Refrigerant Leak Testing	46
Leak Rate	46
Test After Service, Repair, or Major Leak	46
Repair Leaks, Retest, Standing Vacuum Test	46
Checking Guide Vanes	46
Trim Refrigerant Charge	48
WEEKLY MAINTENANCE	48
Check the Refrigerant Lubrication System	48
Check for Leaks	48
SCHEDULED MAINTENANCE	48

Service Ontime	48
Inspect the Control Panel	48
Inspect the Purge	48
Changing Refrigerant Lubrication Filters	49
Inspect Refrigerant Float System	49
Inspect Safety Relief Devices and Piping	49
Compressor Bearing Maintenance	50
Inspect Heat Exchanger Tubes and Flow Devices ..	50
Water Leaks	50
Water Treatment	50
Inspect the VFD	50
Recalibrate Pressure Transducers	51
Recalibrate Temperature Thermistors	51
Ordering Replacement Chiller Parts	51
TROUBLESHOOTING GUIDE	51
Overview	51
Checking Display Messages	51
Checking Temperature Sensors	51
Checking Pressure Transducers	54
High Altitude Locations	55
Quick Test and 19DV Quick Test	55
Quick Calibration	55
Physical Data	55
Active Harmonic Filter Option	81
APPENDIX A — PIC6 SCREEN AND MENU	
STRUCTURE	85
APPENDIX B — CCM COMMUNICATION WIRING	
FOR MULTIPLE CHILLERS (TYPICAL)	88
APPENDIX C — MAINTENANCE SUMMARY	
AND LOG SHEETS	89
INDEX	90
INITIAL START-UP CHECKLIST	CL-1

SAFETY CONSIDERATIONS

Centrifugal liquid chillers are designed to provide safe and reliable service when operated within design specifications. When operating this equipment, use good judgment and safety precautions to avoid damage to equipment and property or injury to personnel.

Be sure you understand and follow the procedures and safety precautions contained in the chiller instructions as well as those listed in this guide.

⚠ DANGER

Failure to follow these procedures will result in severe personal injury or death.

DO NOT VENT refrigerant relief valves within a building. Outlet from rupture disc or relief valve must be vented outdoors in accordance with the latest edition of ANSI/ASHRAE 15 (American National Standards Institute/American Society of Heating, Refrigerating, and Air-Conditioning Engineers). The accumulation of refrigerant in an enclosed space can displace oxygen and cause asphyxiation.

PROVIDE adequate ventilation in accordance with ANSI/ASHRAE 15, especially for enclosed and low overhead spaces. Inhalation of high concentrations of vapor is harmful and may cause heart irregularities, unconsciousness, or death. Misuse can be fatal. Vapor is heavier than air and reduces the amount of oxygen available for breathing. Product causes eye and skin irritation. Decomposition products are hazardous.

DO NOT USE OXYGEN to purge lines or to pressurize a chiller for any purpose. Oxygen gas reacts violently with oil, grease, and other common substances.

NEVER EXCEED specified test pressures; VERIFY the allowable test pressure by checking the instruction literature and the design pressures on the equipment nameplate.

DO NOT USE air for leak testing. Use only refrigerant or dry nitrogen.

DO NOT VALVE OFF any safety device.

BE SURE that all pressure relief devices are properly installed and functioning before operating any chiller.

RISK OF INJURY OR DEATH by electrocution. High voltage can be present on motor leads even though the motor is not running. Open the power supply disconnect before touching motor leads or terminals.

⚠ WARNING

Failure to follow these procedures may result in personal injury or death.

DO NOT USE TORCH to remove any component. System contains refrigerant which may be under pressure.

To remove a component, wear protective gloves and goggles and proceed as follows:

- a. Shut off electrical power to unit.
- b. Recover or isolate refrigerant from system using high-pressure and low pressure ports as appropriate. Note that R-1233zd(E) will be less than atmospheric pressure until a temperature of about 65°F (18.5°C).
- c. Traces of vapor should be displaced with nitrogen and the work area should be well ventilated. Refrigerant in contact with an open flame produces toxic gases.
- d. Cut component connection tubing with tubing cutter and remove component from unit.
- e. Carefully unsweat remaining tubing stubs when necessary.

DO NOT USE eyebolts or eyebolt holes to rig chiller sections or the entire assembly.

DO NOT work on high-voltage equipment unless you are a qualified electrician.

DO NOT WORK ON electrical components, including control panels, switches, or starters, until you are sure ALL POWER IS OFF and no residual voltage can leak from capacitors or solid-state components.

(Warnings continued on next page.)

⚠ WARNING

LOCK OPEN AND TAG electrical circuits during servicing. IF WORK IS INTERRUPTED, confirm that all circuits are de-energized before resuming work.

AVOID SPILLING liquid refrigerant on skin or getting it into the eyes. USE SAFETY GOGGLES. Wash any spills from the skin with soap and water. If liquid refrigerant enters the eyes, IMMEDIATELY FLUSH EYES with water and consult a physician.

NEVER APPLY an open flame or live steam to a refrigerant cylinder. Dangerous overpressure can result. When it is necessary to heat refrigerant, use only warm (110°F [43°C]) water.

VERIFY that refrigerant storage cylinders are clean with no residual moisture, oil, or refrigerant that can contaminate the refrigerant charge.

DO NOT REUSE disposable (nonreturnable) cylinders or attempt to refill them. It is DANGEROUS AND ILLEGAL. When cylinder is emptied, evacuate remaining gas pressure, loosen the collar, and unscrew and discard the valve stem. DO NOT INCINERATE.

CHECK THE REFRIGERANT TYPE before adding refrigerant to the chiller. The introduction of the wrong refrigerant can cause damage or malfunction to this chiller.

Operation of this equipment with refrigerants other than those cited herein should comply with ANSI/ASHRAE 15 (latest edition). Contact Carrier for further information on use of this chiller with other refrigerants.

DO NOT ATTEMPT TO REMOVE fittings, covers, etc., while chiller is refrigerant charged or at any time while chiller is running. Be sure pressure is at 0 psig (0 kPa) before breaking any refrigerant connection. Note that chiller will be in a vacuum condition when temperature is below normal room temperature.

CAREFULLY INSPECT all rupture discs and other relief devices AT LEAST ONCE A YEAR. If chiller operates in a corrosive atmosphere, inspect the devices at more frequent intervals.

DO NOT ATTEMPT TO REPAIR OR RECONDITION any relief device when corrosion or build-up of foreign material (rust, dirt, scale, etc.) is found within the valve body or mechanism. Replace the device.

DO NOT install relief devices in series or backwards.

USE CARE when working near or in line with a compressed spring. Sudden release of the spring can cause it and objects in its path to act as projectiles.

⚠ CAUTION

Failure to follow these procedures may result in personal injury or damage to equipment.

DO NOT STEP on refrigerant lines. Broken lines can whip about and release refrigerant, causing personal injury.

DO NOT climb over a chiller. Use platform, catwalk, or staging. Follow safe practices when using ladders.

USE MECHANICAL EQUIPMENT (crane, hoist, etc.) to lift or move inspection covers or other heavy components. Even if components are light, use mechanical equipment when there is a risk of slipping or losing your balance.

BE AWARE that certain automatic start arrangements CAN ENGAGE THE STARTER, TOWER FAN, OR PUMPS. Open the disconnect *ahead of* the starter, tower fans, or pumps.

USE only repair or replacement parts that meet the code requirements of the original equipment.

DO NOT VENT OR DRAIN waterboxes containing industrial brines, liquid, gases, or semisolids without the permission of your process control group.

DO NOT LOOSEN waterbox cover bolts until the waterbox has been completely drained.

DO NOT LOOSEN a packing gland nut before checking that the nut has a positive thread engagement.

PERIODICALLY INSPECT all valves, fittings, and piping for corrosion, rust, leaks, or damage.

PROVIDE A DRAIN connection in the vent line near each pressure relief device to prevent a build-up of condensate or rain water.

DO NOT leave refrigerant system open to air any longer than the actual time required to service the equipment. Seal circuits being serviced and charge with dry nitrogen to prevent contamination when timely repairs cannot be completed.

INTRODUCTION

Prior to initial start-up of the 19DV unit, those involved in the start-up, operation, and maintenance should be thoroughly familiar with these instructions and other necessary job data. Procedures in this manual are arranged in the sequence required for proper chiller start-up and operation. This book also outlines the control system for those involved in the start-up, operation and maintenance of the unit before performing start-up procedures. It is intended to be used in combination with the 19DV Semi-Hermetic Centrifugal Liquid Chillers Controls Operation and Troubleshooting manual that describes the controls in detail.

⚠ CAUTION

Do NOT punch holes or drill into the top surface of the control or VFD enclosure for field wiring. Knockouts are provided for field wiring connections. Drilling holes through the top of the cabinet can result in a loss of warranty on the starter assembly because of metal particulate falling on and into electronic components.

⚠ CAUTION

PROVIDE MACHINE PROTECTION. Store machine and starter indoors, protected from construction dirt and moisture. Inspect under shipping tarps, bags, or crates to be sure water has not collected during transit. Keep protective shipping covers in place until machine is ready for installation. Follow latest Water-Cooled Chillers Long Term Storage document located in Chiller Builder Library.

⚠ CAUTION

WHEN FLUSHING THE WATER SYSTEMS isolate the chiller from the water circuits to prevent damage to the heat exchanger tubes.

⚠ CAUTION

This unit uses a microprocessor control system. Do not short or jumper between terminations on circuit boards or modules; control or board failure may result.

Be aware of electrostatic discharge (static electricity) when handling or making contact with circuit boards or module connections. Always touch a chassis (grounded) part to dissipate body electrostatic charge before working inside control center or use a grounding strap before handling printed circuit boards.

Use extreme care when handling tools near boards and when connecting or disconnecting terminal plugs. Circuit boards can easily be damaged. Always hold boards by the edges and avoid touching components and connections.

This equipment uses, and can radiate, radio frequency energy. If not installed and used in accordance with the instruction manual, it may cause interference to radio communications. The PIC6 control boards have been tested and found to comply with the limits for a Class A computing device pursuant to International Standard in North America EN 61000-2/3 which are designed to provide reasonable protection against such interference when operated in a commercial environment. Operation of this equipment in a residential area is likely to cause interference, in which case the user, at his own expense, will be required to take whatever measures may be required to correct the interference.

Always store and transport replacement or defective boards in anti-static shipping bag.

ABBREVIATIONS AND EXPLANATIONS

Frequently used abbreviations in this manual include:

AWG	— American Wire Gage
BMS	— Building Management System
CCN	— Carrier Comfort Network®
DCIB	— Digital Control Interface Board
DVM	— Digital Volt-Ohmmeter
EC	— Envelope Control
ECDW	— Entering Condenser Water
ECW	— Entering Chilled Water
EMS	— Energy Management System
HMI	— Human Machine Interface
HVIB	— High Voltage Interface Board
I/O	— Input/Output
IGBT	— Insulated-Gate Bipolar Transistor
IGV	— Inlet Guide Vane
IOB	— Input Output Board
LCDW	— Leaving Condenser Water
LCW	— Leaving Chilled Water
LED	— Light-Emitting Diode
MAWP	— Maximum Allowable Working Pressure
NSTV	— Network Service Tool V
OLTA	— Overload Trip Amps
PIC	— Product Integrated Controls
PPE	— Protective Personal Equipment
PWM	— Pulse Width Modulating
RLA	— Rated Load Amps
RMS	— Root Mean Square
SCCR	— Short Circuit Current Rating
SCR	— Silicon Controlled Rectifier
SIOB	— Starfire 2 Input Output Board
TXV	— Thermostatic Expansion Valve
VFD	— Variable Frequency Drive
VPF	— Variable Primary Flow

Factory-installed additional components are referred to as options in this manual; factory-supplied but field-installed additional components are referred to as accessories.

CHILLER FAMILIARIZATION (Fig. 1 and 2)

Chiller Information Nameplate

The information nameplate is located on the left side of the chiller control panel.

System Components

The main components include the evaporator and condenser heat exchangers in separate vessels, motor-compressor, refrigerant, lubrication package, control panels, PIC6 Touch Screen HMI, economizer, VFD, and purge system.

Evaporator

This vessel is located underneath the compressor. The evaporator is maintained at a lower temperature/pressure so evaporating refrigerant can remove heat from water flowing through its internal tubes. Water flows through the internal tubes to provide comfort or process cooling.

Condenser

The condenser operates at a higher temperature/pressure than the evaporator and has water flowing through its internal tubes in order to remove heat from the refrigerant. It contains a metering device that regulates the flow of refrigerant into the economizer.

Economizer

This chamber reduces the refrigerant pressure to an intermediate level between the evaporator and condenser vessels. In the economizer, vapor is separated from the liquid, the separated vapor flows to the second stage of the compressor, and the liquid flows into the evaporator. The energy removed from the vaporized refrigerant in the economizer allows the liquid refrigerant in the evaporator to absorb more heat when it evaporates and benefits the overall cooling efficiency cycle. It contains a float assembly that regulates the flow of refrigerant into the evaporator.

Motor-Compressor

This component maintains system temperature and pressure differences and moves the heat-carrying refrigerant from the evaporator to the condenser. The 19DV chiller utilizes a two-stage back to back direct drive configuration.

Purge Unit

This is a small independent condensing unit with compressor, separator, regenerative carbon filters, heater and vacuum pump. The purge extracts gas from condenser (or from compressor if unit is not in operation) and purifies it by removing non-condensable gases and any water vapor that may be present.

Variable Frequency Drive (VFD)

The VFD variable frequency is a voltage source design that converts line voltage into PWM (pulse width modulating) motor input for motor speed and torque control.

Refrigerant Lubrication System

This system provides lubrication to the compressor bearing by means of a refrigerant pump.

Chiller Control Panel

This control panel includes the input and output boards (IOBs), control transformer, relays, contactors, and circuit breakers. It provides the power distribution and protection to the electrical components installed on chiller and has the following functions:

- Communication with PIC6 touch screen
- Communication with purge panel
- Communication with VFD
- Sensor input and outputs
- Actuators control
- Refrigerant pump control

Purge Control Panel

The purge panel includes the input and output boards, control transformer, relays, and fuse. It provides the power distribution and protection to the electrical components which installed in the purge system and has the following functions:

- Communication with PIC6 touch screen
- Sensor input and outputs
- Solenoid valve control
- Control of purge compressor, vacuum pump, heater, and fan.

PIC6 Touch Screen HMI

This panel is the user interface for controlling the chiller and has the following functions:

- Chiller operation
- Chiller diagnostic
- Chiller status display
- Chiller parameter configuration
- Provide open protocol interface to outside BMS (Building Management System)

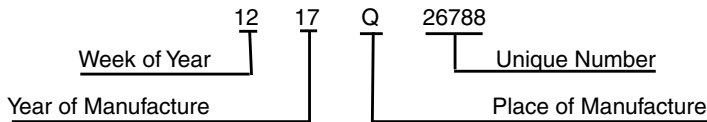
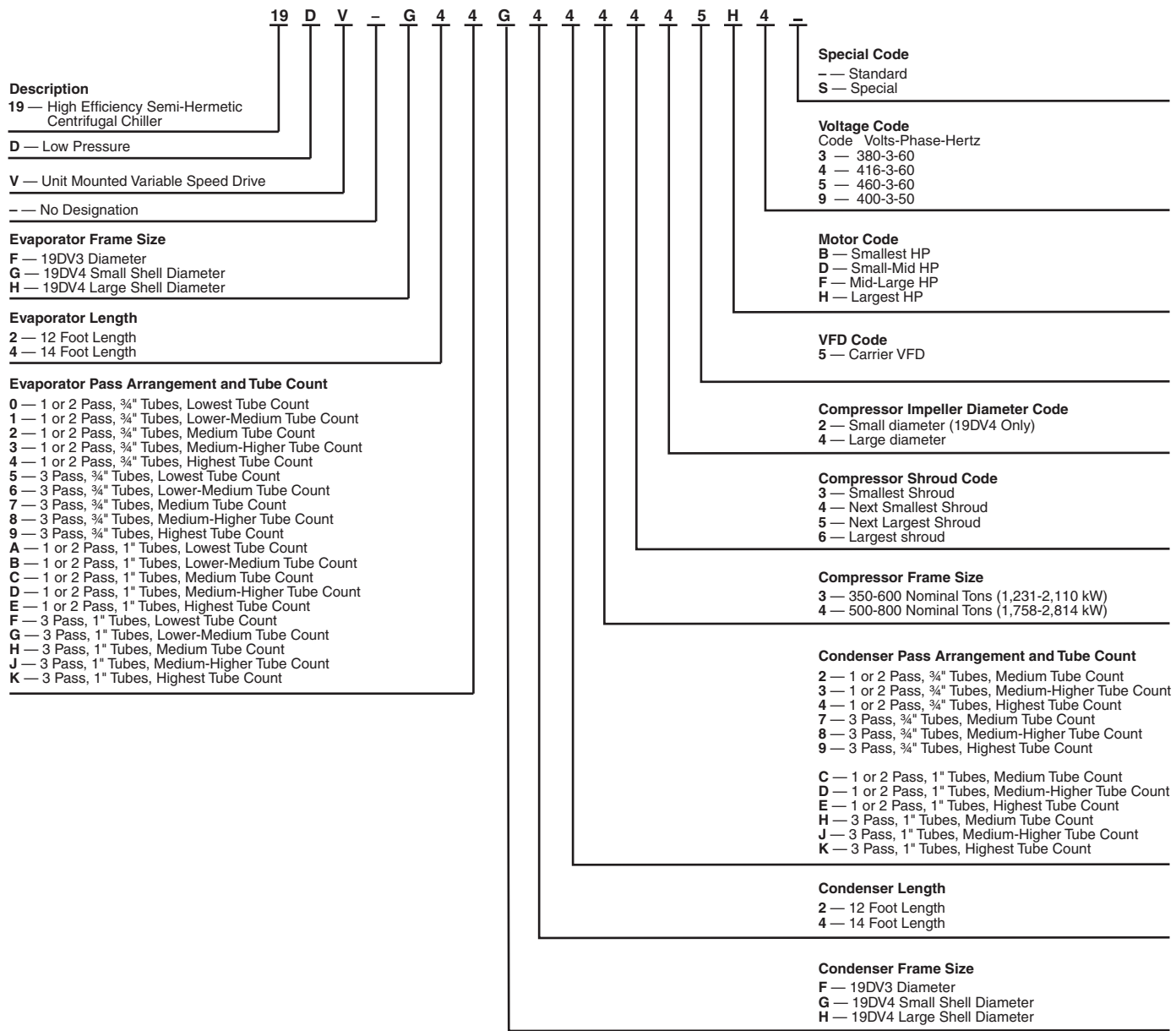

SERIAL NUMBER STRUCTURE

Fig. 1 — 19DV Chiller Model Number Identification

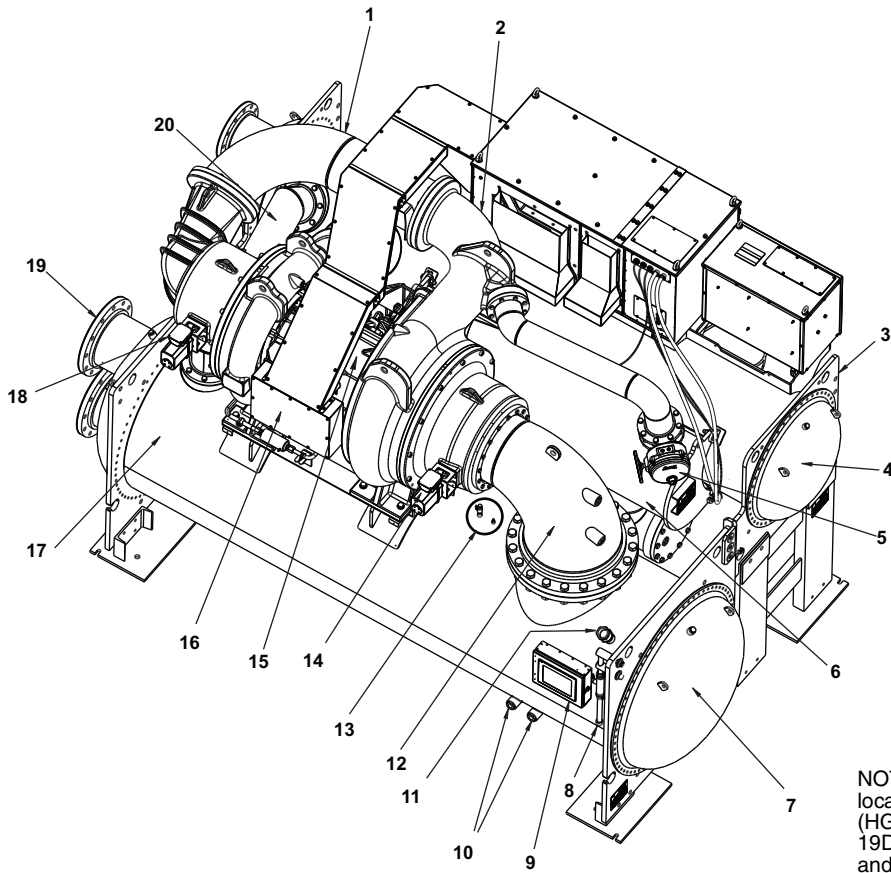

FRONT VIEW

- 1 — Interconnecting Compressor Piping
- 2 — VFD Drain (Field Drain Piping Required)
- 3 — Condenser
- 4 — Condenser Waterbox Return End
- 5 — Economizer Isolation Valve (Option)
- 6 — Economizer
- 7 — Evaporator Waterbox Return End
- 8 — Vacuum/Charging Valve (Hidden)
- 9 — PIC6 HMI Touchscreen Panel
- 10 — Evaporator Bundle Sight Glasses
- 11 — Rupture Disc
- 12 — Suction Elbow
- 13 — Evaporator Charging Valve and Evaporator Pressure Transducer
- 14 — First Stage Guided Vane Actuator
- 15 — Compressor Motor
- 16 — Moisture Indicator (Hidden)
- 17 — Evaporator
- 18 — Second Stage Guided Vane Actuator
- 19 — Evaporator Waterbox Nozzles
- 20 — Free Cooling Pipe (Option)

NOTE: For 19DV3 the free cooling pipe option is located on the suction end while the envelope control (HGBP) pipe remains on the discharge end. For 19DV4 (shown) the envelope control (HGBP) pipe and free cooling pipes are combined (if selected).

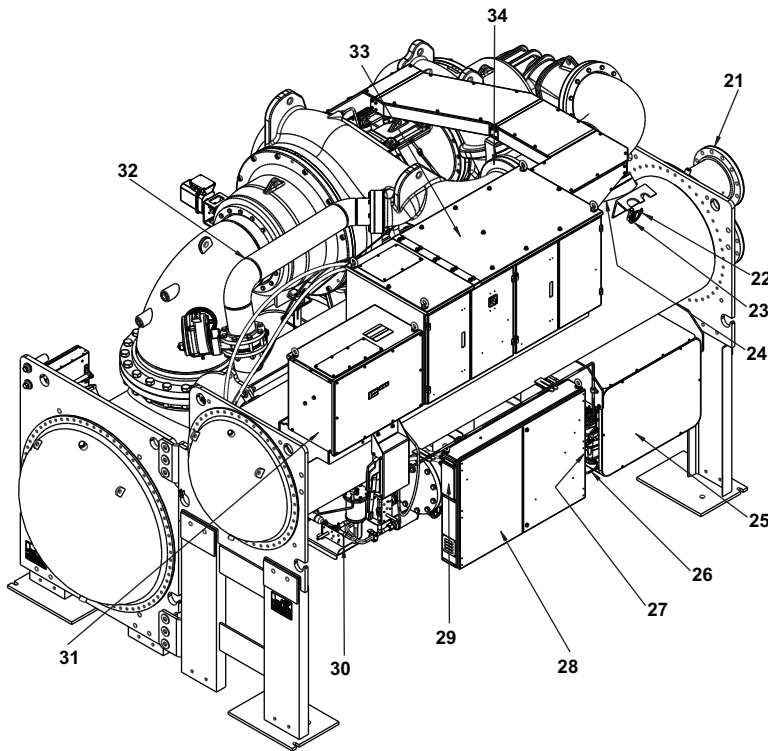

REAR VIEW

- 21 — Condenser Waterbox Nozzles
- 22 — Condenser Pressure Transducer
- 23 — Condenser Charging Valve
- 24 — Envelope Stability Control Pipe
- 25 — Purge Assembly
- 26 — Purge Vent (Hidden)
- 27 — Motor VFD Cooling Moisture Indicator (Hidden)
- 28 — Control Panel
- 29 — Chiller Name Plate Label
- 30 — Lubrication Assembly
- 31 — Pull Box* (replaced by Active Harmonic Filter if selected)
- 32 — Economizer Pipe
- 33 — VFD
- 34 — Discharge Pipe

* Pull Box available on DV4 only.

Fig. 2 — Typical 19DV 350-800 Ton Two-Stage Compressor Chiller Components (DV4 Shown)

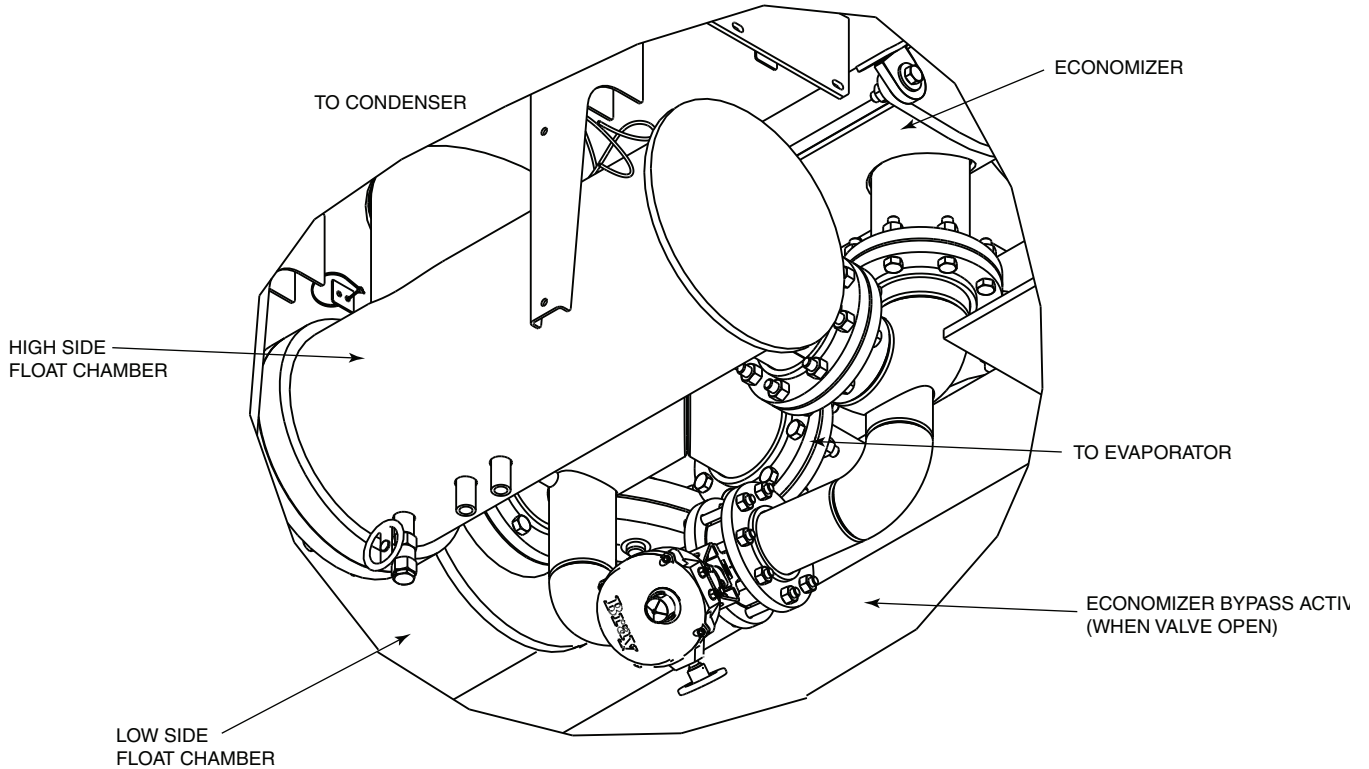
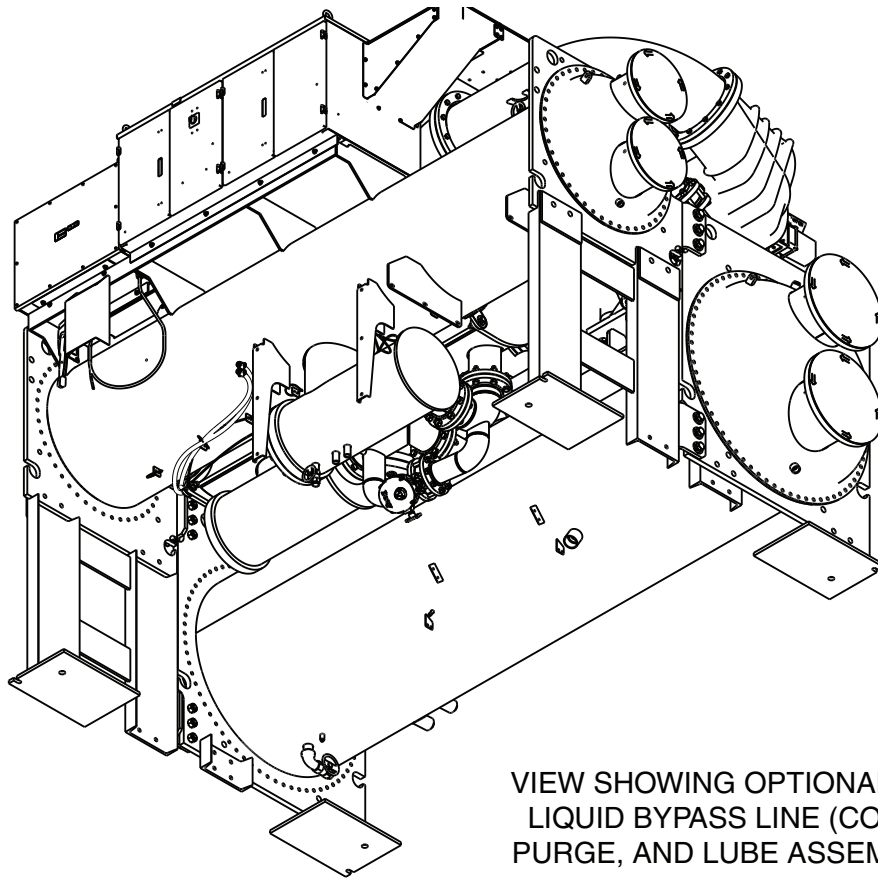

Fig. 2 — Typical 19DV 350-800 Ton Two-Stage Compressor Chiller Components (DV4 Shown) (cont)

REFRIGERATION CYCLE

The compressor continuously draws refrigerant vapor from the evaporator at a rate set by the amount of first stage guide vane opening and motor speed. As the compressor suction reduces the pressure in the evaporator, the remaining refrigerant boils at a fairly low temperature (typically 38 to 42°F [3 to 6°C]). The energy required for boiling is obtained from the water flowing through the evaporator tubes. With heat energy removed, the water becomes cold enough to use in an air-conditioning circuit or process liquid cooling.

After taking heat from the water, the refrigerant vapor is compressed by a back-to-back compression connected by means of interstage piping. Compression adds heat energy and the refrigerant is quite warm (typically 98 to 102°F [37 to 40°C]) when it is discharged from the compressor into the condenser.

Relatively cool (typically 65 to 90°F [18 to 32°C]) water flowing into the condenser tubes removes heat from the refrigerant, and the vapor condenses to liquid. The liquid drains into a high side float valve chamber between the condenser and the economizer. The refrigerant is then metered into the economizer. In

the economizer, due to lower pressure, as liquid enters the chamber, some liquid will flash into a vapor and cool the remaining liquid. The separated vapor flows to the second stage of the compressor for greater cycle efficiency. The second stage guide vane on the compressor acts as a pressure regulating device to stabilize operating conditions. At part load the second stage guide vane will back up gas flow and thereby raises the economizer pressure to allow appropriate refrigerant flow from economizer to the compressor.

The cooled liquid left in the economizer flows through a low side float valve and then into the evaporator. The float valve forms a liquid seal to keep vapor from entering the evaporator. The refrigerant is now at a temperature and pressure at which the cycle began. Figures 3 and 4 summarize the refrigeration cycle.

The 19DV unit utilizes R-1233zd(E) refrigerant. At atmospheric pressure its boiling point is 65.5°F (18.6°C). The result is that at normal operating conditions the evaporator typically will be in a vacuum condition and the condenser will operate at a pressure above atmospheric pressure. Unit near room temperature will be close to atmospheric pressure.

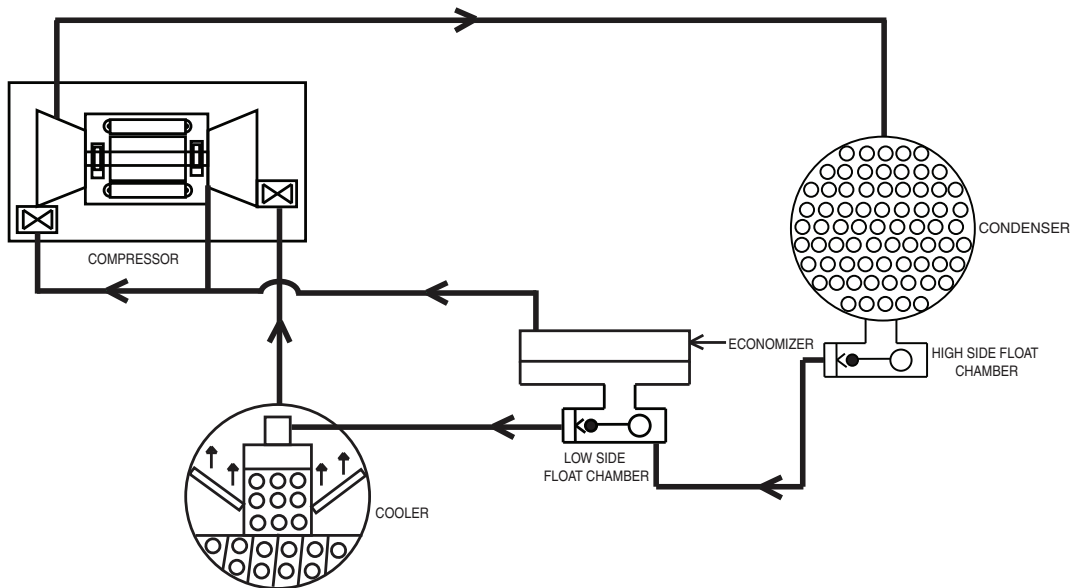

Fig. 3 — Refrigeration Cycle — 19DV Two-Stage Compressor (No Options)

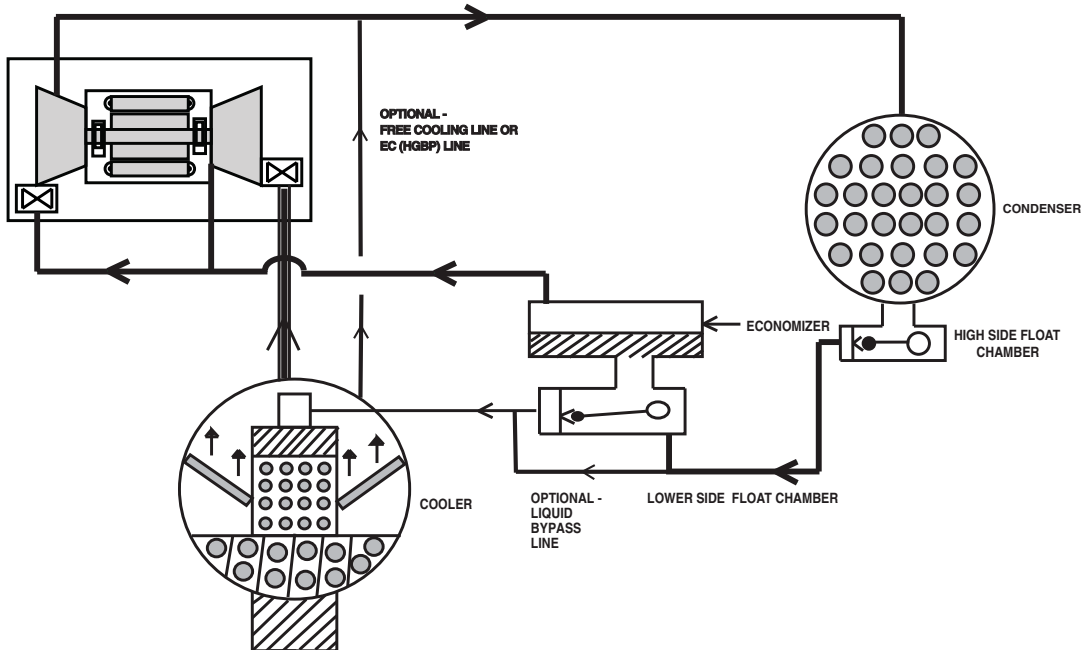

Fig. 4 — Refrigeration Cycle — 19DV Two-Stage Compressor with Free Cooling and Liquid Bypass Options

CAUTION

To avoid adverse effects on chiller operation, considerations must be made to condenser water temperature control. For steady state operation, the minimum operating refrigerant pressure differential between evaporator and condenser is approximately 7 psid (48 kPa) with a maximum evaporator refrigerant temperature of 65°F (18°C). Consult Chiller Builder for required steady state operational limits and low lift options. Inverted start conditions are acceptable for short durations of time, but for periods exceeding 5 minutes, a special control solution strategy should be used to allow the chiller to establish a minimum refrigerant pressure differential (and thereby adequate equipment cooling).

REFRIGERANT LUBRICATION CYCLE

Summary

The 19DV Series chiller uses refrigerant to lubricate the bearings. The lubrication control is automatically controlled by the chiller controls. In normal RUN mode refrigerant is pumped by means of a refrigerant pump from the high side condenser float chamber to the bearings. Prior to start-up, liquid level in the high

side condenser float chamber is maintained by pumping refrigerant liquid from the evaporator to the high side float chamber until level sensor is satisfied. If liquid high side float level is not satisfied, the pump will move refrigerant from the evaporator to the condenser. During pre-lube and post-lube cycles, refrigerant is drawn from the evaporator for bearing lubrication.

Figures 5 and 6 identify the refrigerant lubrication assembly. Supply refrigerant is pulled through a filter drier by the refrigerant pump and is pumped to the bearings through two protective filters and then returned to the evaporator.

There are two pressure sensors located across the refrigerant pump. During RUN mode a minimum of 10 psid is required for the refrigerant pump delta difference. Consult the 19DV with PIC6 Controls Operation and Troubleshooting manual for details.

Bearings

The 19DV motor-compressor assembly includes two matched sets of refrigerant-lubricated bearings. The motor shaft is supported by a combination set of journal bearing and roller element bearings on each end of compressor. The refrigerant lubrication pressure difference is defined as the bearing input pressure minus the bearing output pressure plus the Refrigerant Delta P Offset.

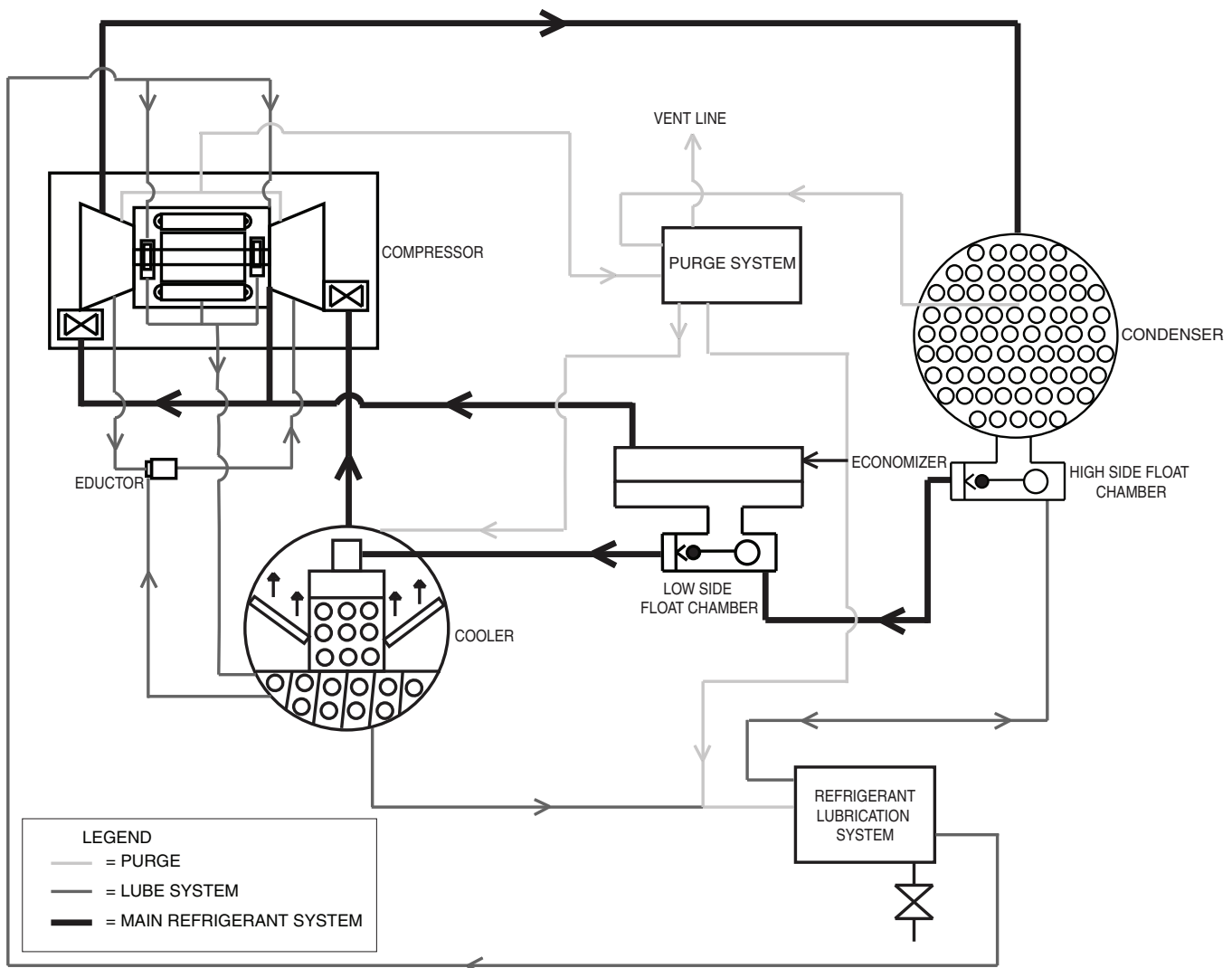

Fig. 5 — Refrigerant Lubrication Cycle

NOTE: VALVES SHUT AT FACTORY TO CONTAIN INHIBITOR IN LUBRICATION ASSEMBLY. IMPORTANT: OPEN THESE VALVES PRIOR TO STARTUP.

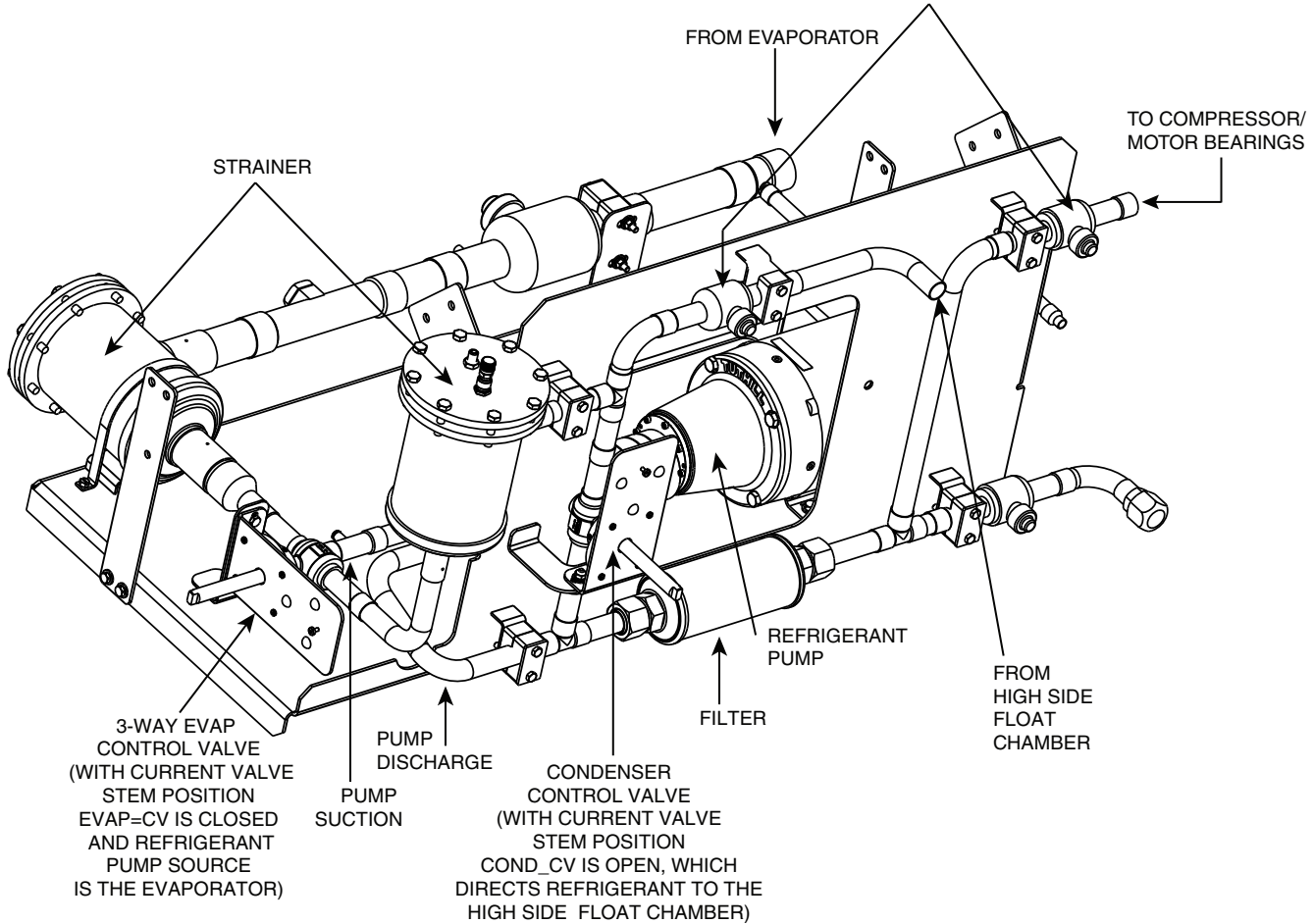

Fig. 6 — Refrigerant Lubrication Assembly

Inhibitor Reclaim System

The inhibitor reclaim system moves inhibitor from the evaporator and returns it to the first stage suction inlet which allows it to be mixed in the system since it has a tendency to have higher concentration in the evaporator compared with the rest of the system. The reclaim is powered by an eductor driven by the gas pressure difference between first stage suction and discharge of second stage.

Motor Cooling System

The motor is cooled by liquid refrigerant taken from the bottom of the high side condenser float chamber. Refrigerant flow is maintained by the pressure differential that exists due to compressor operation. After the refrigerant flows past an isolation valve, an in-line filter drier, and a sight glass/moisture indicator, it is directed over the motor by spray nozzles. When the chiller is operating there should be turbulent two phase flow of refrigerant visible in the sight glass. The refrigerant collects in the bottom of the motor casing and is then drained back into the evaporator through the motor refrigerant drain line. The motor is protected by temperature thermistors embedded in the stator windings. An increase in motor winding temperature past the motor override set point overrides the temperature capacity control to hold, and if the motor temperature exceeds 10°F (5.5°C) above this set point, the controls close the inlet guide vanes. If the temperature rises above 122°F (50°C), the compressor shuts down. See Fig. 7.

VFD Cooling System

The VFD enclosure is sealed from the atmosphere to protect electronics from outside contaminants. Refrigerant is routed through a coil in the VFD enclosure to regulate enclosure temperature while still maintaining a temperature high enough to prevent condensation. The VFD cooling line is branched off the motor cooling supply. The refrigerant is then drained back into the evaporator through the motor/VFD drain line. Rectifier and inverter sections are air-cooled and protected by temperature sensors embedded in the inverter. An increase in inverter temperature past the override set point overrides the temperature capacity control to hold, and if the temperature exceeds 10°F (5.5°C) above this set point, the controls close the inlet guide vanes. If the IGBT temperature rises above 144°F (80°C), the compressor shuts down. See Fig. 7.

VFD

All 19DV units are equipped with a VFD to operate the centrifugal semi-hermetic compressor motor. The VFD and control panel are the main field wiring interfaces for the installing contractor. The VFD and control panel are mounted on the chiller. See Manufacturer VFD specific information and VFD schematics.

VFD model 32VS is designed to operate in an ambient range of up to 104°F (40°C). The drive has two control circuit boards.

The Digital Control Interface Board (DCIB) controls the fans for cooling operation. In addition the DCIB controls insulated-gate bipolar transistors (IGBTs), measures three phase line current, controls temperature input and cooling solenoid, controls outputs for pilot relays, and controls communication with HMI controller.

The High Voltage Interface Board (HVIB) steps down incoming voltage to 24 VAC and sends this to the DCIB for monitoring. The HVIB measures DC Bus voltage, controls the pre-charge circuit, and controls SCR gating. It contains watchdog LED to confirm DC Bus potential is depleted.

If the drive needs to be removed, use the 4 lifting lugs. See Fig. 8. The drive is compatible with the Network Service Tool V (NSTV) for diagnostics.

The 32VS drive is available with an active harmonic filter option (AHF) high tier option. The active harmonic filter regulates harmonics to bring the total harmonic distortion in compliance with IEEE-519-2014. The AHF adds 600 lbs (272 Kg) to the weight of the drive. See Fig. 9 for standard tier with pull box and Fig. 10 for high tier with AHF.

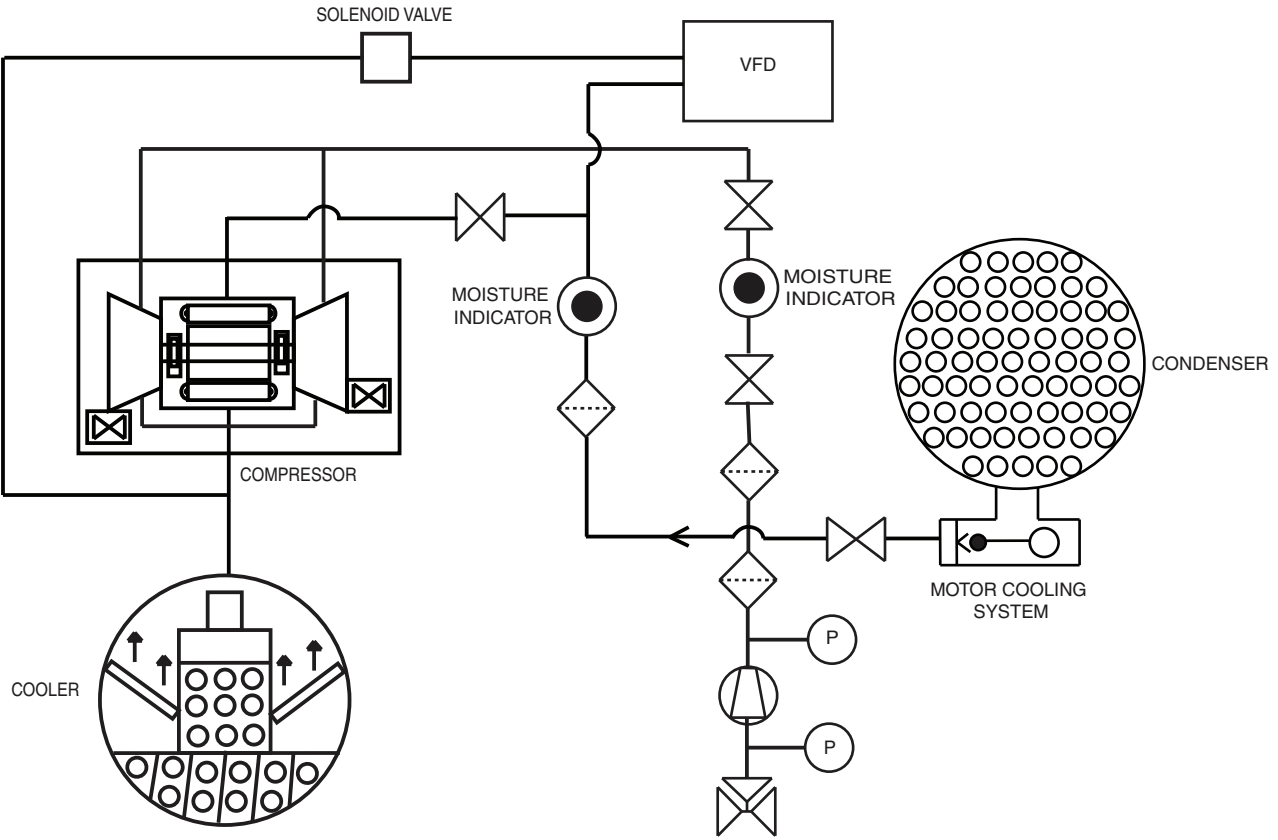
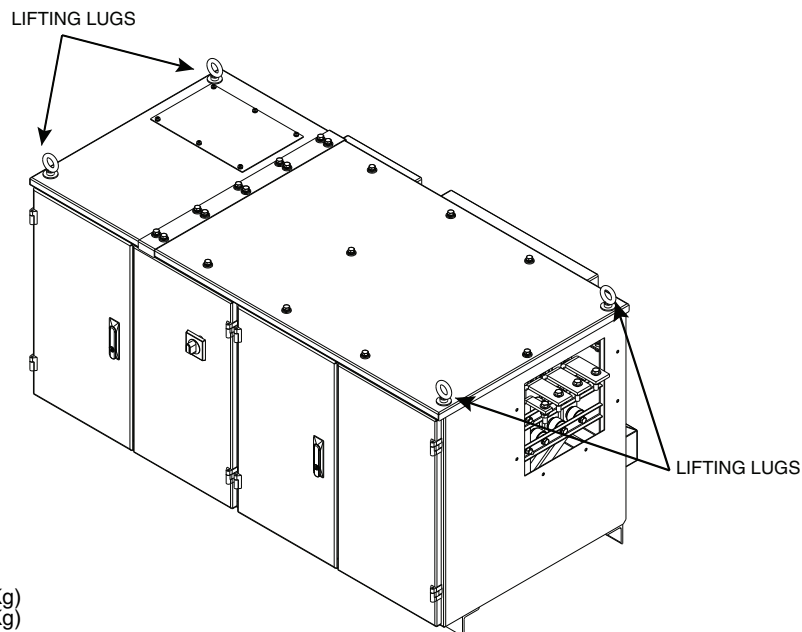

Fig. 7 — Motor/VFD Cooling System



Weight:
 32VSS0850 = 1650 lbs (748 Kg)
 32VSS0680 = 1354 lbs (614 Kg)

Fig. 8 — 32VS (850A Shown)

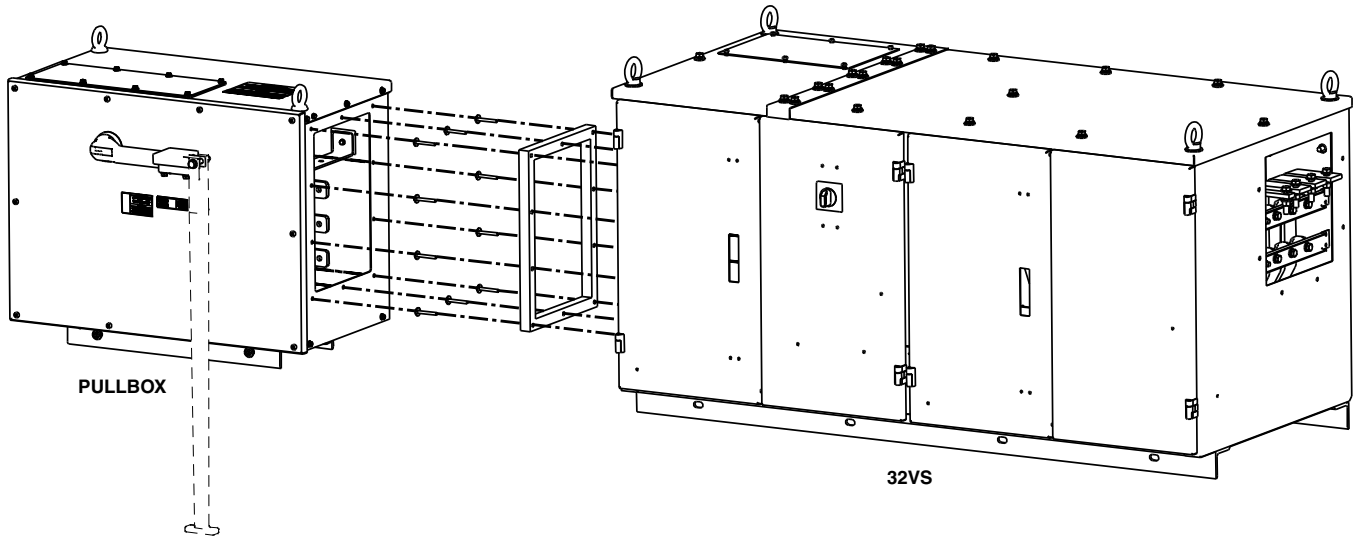

Fig. 9 — 32VS Standard Tier VFD with Pull Box (850 Amp VFD Only)

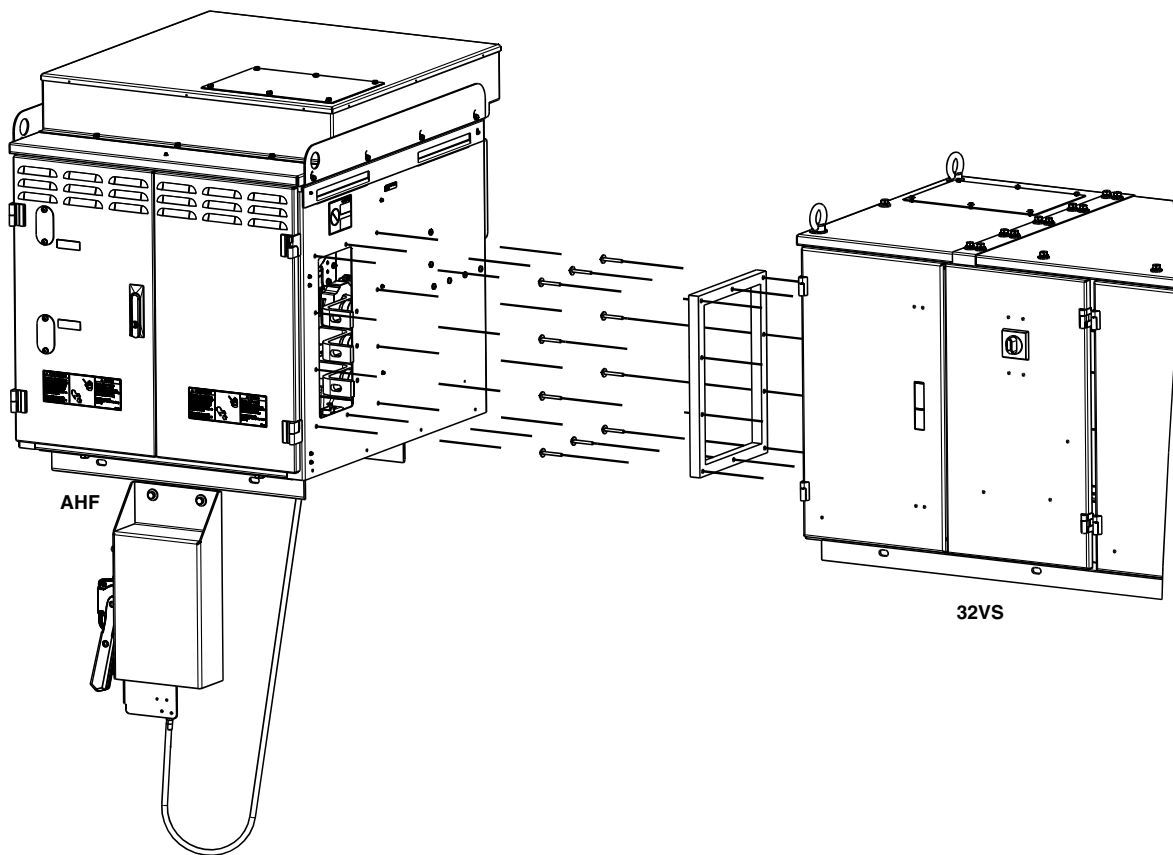

Fig. 10 — 32VS High Tier VFD with AHF

Purge System

The purge system is located under the condenser. See Fig. 11. It has two gas inlets coming from condenser and compressor. When chiller is running, the condenser line is active/open and non-condensable gas is pulled out from condenser; when chiller is idle and purge on idle option is enabled, the compressor line is active and non-condensables are pulled out from compressor volute. This is implemented due to non-condensable gas density being less than refrigerant and therefore it will accumulate at the highest point when chiller is not running.

In the purge tank the purge gas is cooled by a separate integral R-134a cooling system. The cooling system consists of an compressor, an air cooled condenser coil, an expansion valve, and a cooling coil in purge tank. Cooling the purge gas results in condensation of R-1233zd(E) vapor as it touches the coil, resulting in a vacuum with the result that more refrigerant is pushed to the coil. As the purge tank fills up with refrigerant it will be drained through the purge drain to the refrigerant pump assembly. See Fig. 12.

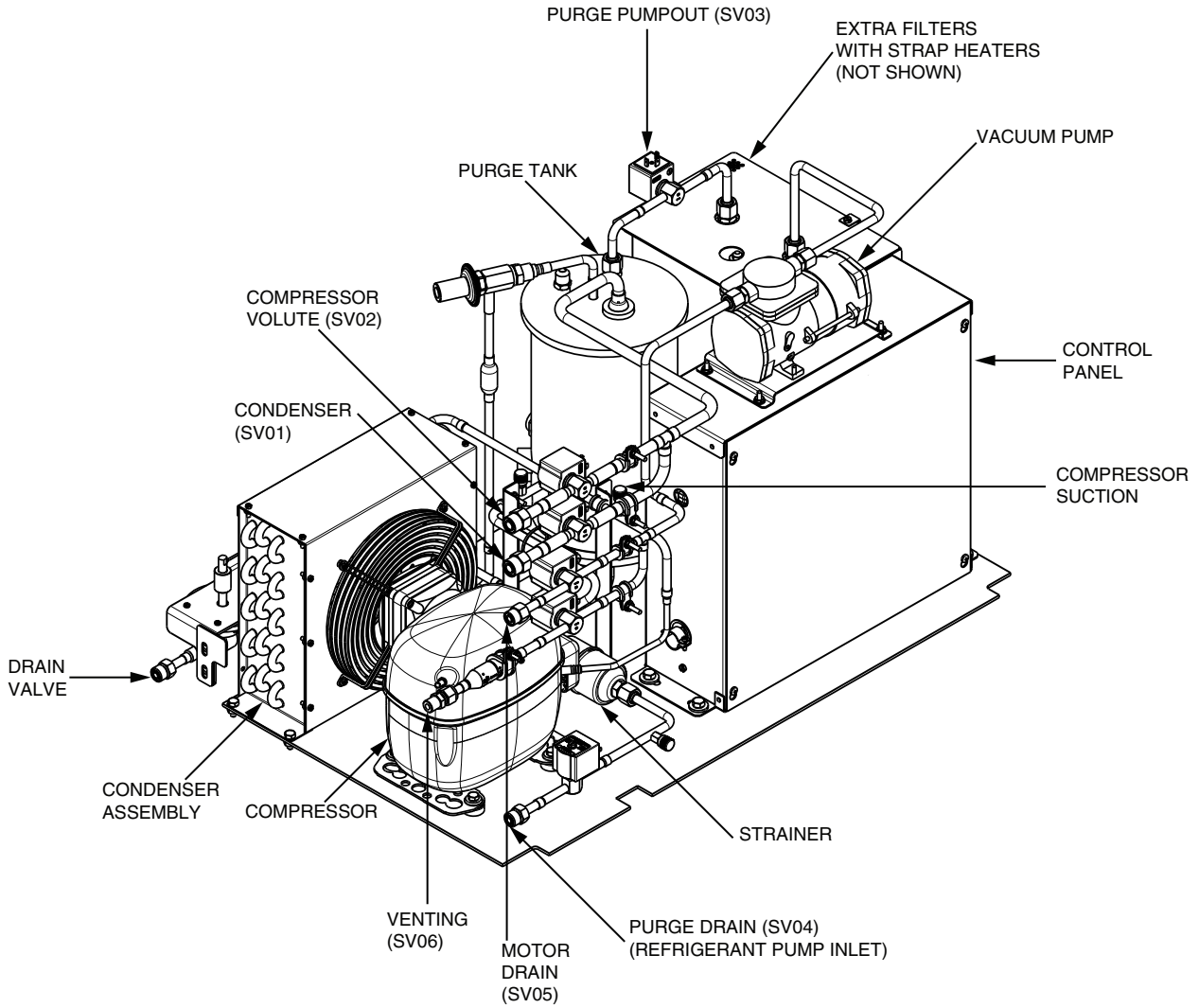

Fig. 11 — Purge System

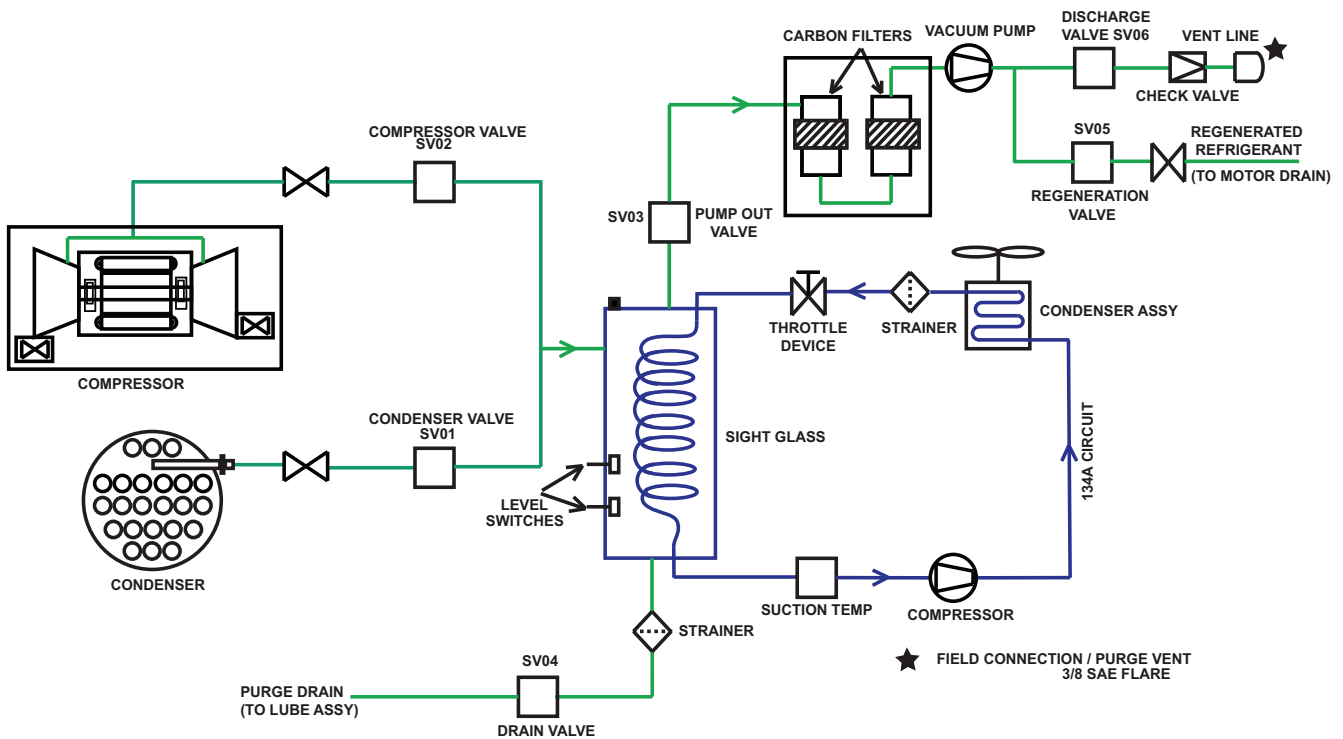

Fig. 12 — Purge Assembly

Non-condensables that come into contact with the cold coil in the purge tank will not condense and will accumulate at the top of the purge tank, raising the pressure and reducing the flow of refrigerant vapor. When the controls sense that there is sufficient non-condensable gas in the purge tank, the control will open the pumpout valve, activate the purge evacuation pump, and force the gas through the active carbon filters. The active carbon filters absorb remaining refrigerant prior to discharging the non-condensables through the vent line. As the carbon filters become saturated, the system will regenerate the filters by applying heat to the filters while under vacuum and then disperse the regenerated refrigerant back through the motor drain to the evaporator.

The 19DV purge control is automatic. Purge control should be active when purge inlet temperature (evaporator refrigerant liquid temp when chiller compressor OFF or condenser saturated temperature when chiller compressor ON) is greater than purge active temperature set point (65°F default [18.3°C]).

If chiller compressor is running, condenser solenoid valve should be opened to purge refrigerant from condenser.

If Purge On Idle Option is enabled, then if chiller compressor is not running, the purge will still be active. In this configuration the controls will open the compressor solenoid valve to purge refrigerant from compressor. The other valves (Purge idle drain valve, Purge drain valve (SV04), Purge pump out valve (SV03) and Purge discharge valve (SV06), Purge Vacuum Pump, Purge Heater) shall be closed/off.

PURGE DISCHARGE

Conditions for purge discharge are as follows:

When chiller compressor is running:

- Purge Compressor Suction Temp is less than Purge Discharge Temp (default to 8°F [-13.3°C]) and Purge Level Switch Low = Open

When chiller compressor is not running (Purge On Idle Option = Enable):

- Purge Compressor Suction Temp is less than Purge Discharge Temp (default to 8°F [-13.3°C]) and Low Level Switch is open
- Purge Compressor Suction Temp is less than Purge Drainage Temp (default to 9°F [-12.8°C]) and Low Level Switch is closed for PG Discharge Wait Time (default to 1 minute).

Discharge is initiated by closing condenser (SV01) and compressor (SV02) solenoid valves, while turning on pump out (SV03) and Discharge (SV06) solenoid valves and vacuum pump. After Purge Discharge Time (default to 5s) it will delay for PG Discharge Delay Time (default 30s).

During delay the following occur: Pump out (SV03), Discharge valve (SV06) and purge vacuum pump are turned off and if chiller compressor is running condenser solenoid valve (SV01) is opened. Alternatively if compressor is not running and Idle option has been enabled then the compressor solenoid valve (SV02) is opened.

After the PG Discharge Delay Time has expired the above condition for purge discharge is checked again.

PURGE DRAINAGE

Conditions for purge drainage are as follows:

When chiller compressor is running:

- Refrigerant level in purge tank is high (Purge Level Switch High = Close)
- Purge Compressor Suction Temp is less than Purge Drainage Temp (default to 9°F [-12.8°C]) and Low Level Switch is closed for PG Discharge Wait Time (default to 1 minute).

Drainage is initiated by keeping condenser (SV01) open while opening compressor (SV02) and purge drain (SV04) valve. The purge compressor is stopped while draining.

When chiller compressor is not running (Purge On Idle Option = Enable):

- Refrigerant level in purge tank is high (Purge Level Switch High = Close) for 1 minute.

Drainage in this mode is initiated by running purge compressor while opening condenser (SV01) and compressor (SV02) solenoid valves. The purge drain (SV04) remains closed and after 20s the purge idle drain valve opens. When this valve opens, the lube assembly refrigerant pump will turn on, moving refrigerant from the evaporator and discharging to the compressor bearings, and thereby help draining the purge tank which drains into the motor drain / evaporator.

Once the Low Level Switch has been open for 180 seconds, then purge idle drain valve will close and purge compressor and condenser (SV01) and compressor (SV02) will be released to normal operation.

PURGE REGENERATION

Once the pump out solenoid valve has been ON for 30 minutes (in 5 sec intervals), the, purge system will complete a regeneration process for Purge Regen Lasting Time (default = 120 minutes – 19DV Configuration Menu), regardless whether purge is active. When regeneration process is active, the Purge Regeneration Valve and Purge Heater will open for Purge Regen Lasting Time, and purge vacuum pump should be on for 3 minutes and then 10 minutes off, alternating during regeneration process.

Upon regeneration completion, purge system will wait for another 4 hours to let carbon filter cool down before it will operate normally.

⚠ WARNING

The main circuit breaker (if equipped) on the front of the starter disconnects the main motor power only. Power may be still energized for other circuits. Always check wiring diagrams before initiating any work on the chiller and follow applicable lock-out/tag-out procedures. Failure to disconnect power will result in personal injury.

CONTROLS

Definitions

ANALOG SIGNAL

An *analog signal* varies in proportion to the monitored source. It quantifies values between operating limits. For example, a temperature sensor is an analog device because its resistance changes in proportion to the temperature, generating many values.

DISCRETE SIGNAL

A *discrete signal* is a 2-position representation of the value of a monitored source. For example, a switch produces a discrete signal indicating whether a value is above or below a set point or boundary by generating an on/off, high/low, or open/closed signal.

General

The 19DV centrifugal liquid chiller contains a microprocessor-based control center that monitors and controls all operations of the chiller. The microprocessor control system matches the cooling capacity of the chiller to the cooling load while providing state-of-the-art chiller protection. The system controls cooling load within the set point plus the deadband by sensing the leaving chilled water or brine temperature and regulating the inlet guide vanes and compressor speed. The guide vane is a variable flow pre-whirl assembly that controls the refrigeration effect in the evaporator by regulating the amount of refrigerant vapor flow into the compressor. An increase in guide vane opening increases capacity. A decrease in guide vane opening decreases capacity. The

microprocessor-based control center protects the chiller by monitoring the digital and analog inputs and executing capacity overrides or safety shutdowns, if required. The variable frequency drive (VFD) allows compressor start-up and capacity control by modulating the motor frequency based on the operating condition.

PIC6 System Components

The chiller control system is called the PIC6 (Product Integrated Control 6). See Table 1. As with previous PIC versions, the PIC6 system controls the operation of the chiller by monitoring all operating conditions. The PIC6 control system can diagnose a problem and let the operator know what the problem is and what to check. It positions the guide vanes and VFD speed to maintain leaving chilled water temperature. It controls the refrigerant pump providing compressor bearing lubrication and can interface with auxiliary equipment such as pumps and cooling tower fans to turn them on when required. It continually checks all safeties to prevent any unsafe operating condition. It regulates the envelope control valve for stabilized aerodynamic operation, if installed. The PIC6 controls offer an operator trending function to help the operator monitor the chiller status more easily and for critical compressor motor protection. The PIC6 system provides open protocols to support the competitive BMS system and can be integrated into Carrier’s Lifecycle System Management for remote monitoring and data management.

Table 1 — Major Controls Components and Panel Locations

PIC6 COMPONENT	PANEL LOCATION
Variable Frequency Drive (Standard Tier, High Tier)	Top of condenser
Active Harmonic Filter (Option, High Tier)	Top of condenser
Purge Panel	Under condenser
Remote Monitoring	Control Panel
Control Panel	Under condenser
HMI	Standard location on side of cooler

NOTE: For detailed information about the PIC6 HMI (human machine interface), see the 19DV with PIC6 Controls Operation and Troubleshooting manual.

START-UP/SHUTDOWN/RECYCLE SEQUENCE

Local Start/Stop Control

Local start-up (or manual start-up) is initiated by pressing the gray Start/Stop icon on the HMI interface. See Fig. 13.

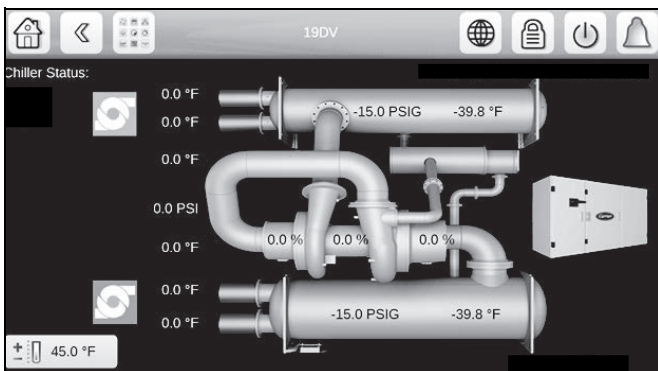



Fig. 13 — Chiller Start/Stop Icon

This initiates the PIC6 starting sequence by displaying the list of operating modes. Press Local On to initiate start-up. See Fig. 14.

Prior to start-up the start-to-start timer and the stop-to-start timer must have elapsed and all alarms must be cleared (see Troubleshooting Guide section).

When start-up is initiated the status screen displays the start-up progress and the Start/Stop icon  blinks green.

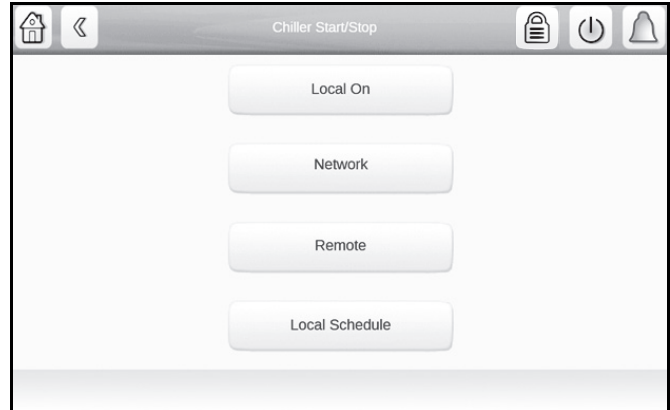

Fig. 14 — Local On

Once local start-up begins, the PIC6 control system performs a series of prestart tests to verify that all prestart alerts and safeties are within acceptable limits. Table 2 shows appropriate Prestart Alerts/Alarms conditions. If a test is not successful, the start-up is delayed or aborted. If the tests are successful, the start-up will be in progress and the COMPRESSOR RUN STATUS will be “Startup.” The control will then energize the chilled water/brine pump relay.

Five seconds later, the condenser pump relay energizes. Thirty seconds later the PIC6 control system monitors the chilled water and condenser water flow devices and waits until the *WATER FLOW VERIFY TIME* (operator-configured, default 5 minutes) expires to confirm flow. After flow is verified, the chilled water temperature is compared to *CONTROL POINT* plus *1/2 CHILLED WATER DEADBAND*. If the temperature is less than or equal to this value, the PIC6 control system turns off the condenser pump relay and goes into a Recycle mode.

If the water/brine temperature is high enough, the start-up sequence continues and checks the guide vane position. If the guide vanes are more than 4% open, the start-up waits until the PIC6 control system closes the vanes. If the vanes are closed and the refrigerant pump pressure difference is less than 2.5 psid (17.2 kPa), the refrigerant pump relay energizes. The PIC6 control system then waits until the refrigerant pressure (REF PRESS VERIFY TIME, operator-configured, default of 20 seconds) reaches 12 psid (82.7 kPa). After refrigerant pressure is verified, if high side float chamber has adequate liquid level, refrigerant pump will be kept ON for 10 seconds for pre-lube; if not, refrigerant pump will be kept ON pumping refrigerant from evaporator to the high side float chamber until liquid level is satisfied. Upon pre-lube satisfied the compressor start relay is energized.

Compressor ontime and service ontime timers start, and the compressor *STARTS IN 12 HOURS* counter and the number of starts over a 12-hour period counter advance by one.

Failure to verify any of the requirements up to this point will result in the PIC6 control system aborting the start and displaying the applicable prestart alert alarm state number near the bottom of the home screen on the HMI panel. A prestart failure does not advance the *STARTS IN 12 HOURS* counter. Any failure after the ICR/Start relay has energized results in a safety shutdown, advances the starts in 12 hours counter by one, and displays the applicable shutdown status on the display.

The minimum time to complete the entire prestart sequence is approximately 185 seconds. See Fig. 15 for normal start-up timing sequence. See Table 2 for a list of prestart checks.

Table 2 — Prestart Checks

PRESTART CHECK CONDITION*	STATE NUMBER†
STARTS IN 12 HOURS \geq 8 (not counting recycle restarts or auto restarts after power failure)	Alert – 100
COND PRESSURE \geq COND PRESS OVERRIDE – 20 psi	Alert – 102
#RECYCLE RESTARTS LAST 4 HOURS > 5	Alert – 103
COMP BEARING TEMP \geq COMP BEARING ALERT – 10°F (5.6°C)	Alarm – 230
COMP MOTOR WINDING TEMP \geq COMP MOTOR WINDING – 10°F (5.6°C)	Alarm – 231
COMP DISCHARGE TEMPERATURE \geq COMP DISCHARGE ALERT – 10°F (5.6°C)	Alarm – 232
EVAP_SAT <Evap trip point** + EVAP OVERRIDE DELTA T	Alarm – 233
EVAP REFRIG LIQUID TEMP <Evap trip point** + EVAP OVERRIDE DELTA T	Alarm – 233
AVERAGE LINE VOLTAGE \leq UNDERVOLTAGE THRESHOLD	Alarm – 234
AVERAGE LINE VOLTAGE \geq OVERVOLTAGE THRESHOLD	Alarm – 235
CHECK FOR GUIDE VANE 1 CALIBRATION	Alarm – 236
CHECK FOR GUIDE VANE 2 CALIBRATION	Alarm – 238

* If Prestart Check Condition is True, then resulting State is as indicated in the State Number column.
 † See the Controls Operation and Troubleshooting guide for alarm and alert codes.
 ** Evap trip point = 33°F (0.6°C) (water) or EVAP REFRIG TRIPPOINT (brine).

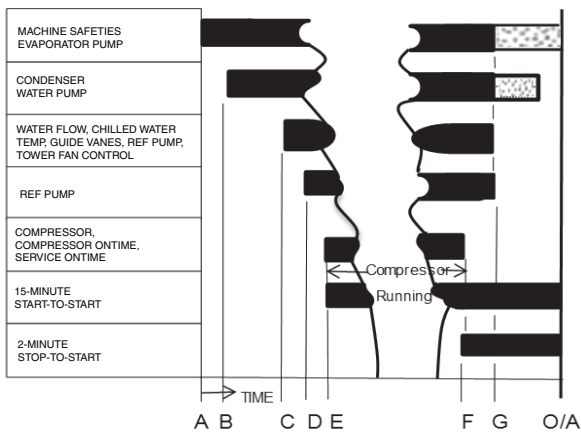

A	START INITIATED: prestart checks are made; evaporator pump started.*
B	Condenser water pump started (5 seconds after A).
C	Water flows verified (30 seconds to 5 minutes maximum after B). Chilled water temperatures checked against control point. Guide vanes checked for closure. Refrigerant pump started; tower fan control enabled.
D	Ref pressure verified (15 seconds minimum, 300 seconds maximum after C).
E	Compressor motor starts; compressor on-time and service on-time start, 15-minute inhibit timer starts (10 seconds after D), total compressor starts advances by one, and the number of starts over a 12-hour period advances by one.
F	SHUTDOWN INITIATED; Compressor motor stops; compressor on-time and service on-time stop, and 2-minute inhibit timer starts.
G	Refrigerant pump and evaporator pumps de-energized (120 seconds after F). Condenser pump and tower fan control may continue to operate if condenser pressure is high. Evaporator pump may continue if in RECYCLE mode.
O/A	Restart permitted (both inhibit timers expired: minimum of 15 minutes after E; minimum of 2 minutes after F).

* Auto Restart After Power Failure Timing sequence will be faster.

Fig. 15 — Control Timing Sequence for Normal Start-Up

Lubrication Control

For the 19DV system, refrigerant is used to lubricate and cool the compressor bearings. The refrigerant lubrication system includes refrigerant pump pressure transducers, control valves, filters, liquid level switch and inhibitor reclaim system. See Table 3 for more information about control valves position depending on chiller status, Fig. 16 for the lube assembly schematic, and Fig. 6 for the lube assembly.

When the chiller is powered on, the controller will maintain the liquid level in the condenser float chamber. If liquid level is low, refrigerant will be pumped from evaporator to the condenser high side float chamber until the liquid level switch is ON. Once the operator pushes the start button, the system will go into prestart check process.

Upon passing prestart checklist the unit enters startup mode. If the refrigerant pump pressure differential is less than or equal to 5 psig without the refrigerant pump energized, the pump will be allowed to start. The refrigerant pump pressure differential must reach 8 psig to continue at which point the unit will start precharging the high side float reservoir with refrigerant. The objective is to fill enough refrigerant into the high side float chamber to close the low level switch.

After precharge, if the refrigerant pump pressure difference is less than 8 psid (55.2 kPa) for 8 seconds continuously, the chiller will shut down. Once acceptable pump pressure has been established, the bearings will typically be prelubed for 20 seconds. During prelube the bearings will be supplied refrigerant from the high side float chamber (see Table 3 for cooler and condenser control valve positions). Note that the initial prelubrication period is approximately 30 minutes. The Quick Calibration Menu “Ref Lub 1st Test Status = No” indicate that this first pre-lubrication period has not been completed. The compressor will run after the prelubrication process. Like in prelube, refrigerant from the high side condenser float chamber will be pumped to bearings and will drain to evaporator. When chiller shuts down, both condenser and evaporator control valve will close (3-way valve will connect evaporator to pump suction). This position allows refrigerant to be pumped from evaporator to condenser high side float chamber. While running, if compressor is ON and the refrigerant pump pressure difference is less than 10 psid (68.9 kPa) for 10 seconds continuously, the chiller will shut down.

Table 3 — Lube Assembly Control Valve (CV)

STATUS	CONTROL VALVE		DESCRIPTION
	EVAPORATOR	CONDENSER	
CHILLER OFF	Close	Close	Chiller is off - a start is to be initiated to change state.
PRE-START	Close	Open	Refrigerant pump turns on if pump differential pressure is less than 5 psig - if differential pressure higher Alarm 285 will be displayed.
PRE-CHARGE	Close	Open	Objective is the charge the high side float with refrigerant. If high side float chamber level switch is not closed the refrigerant will be pumped from the evaporator to the high side float chamber until the high side float chamber level switch is satisfied. If level switch is not closed after 10 minutes alert 163 will be active and startup will stop. Once high side float chamber switch is satisfied the pre-charge process pumping liquid to the high side float chamber will continue for 1 minute.
PRE-LUBE	Open	Close	Upon completion of the pre-charge state the controls will verify that the pump refrigerant differential pressure is greater than the limit (typically 8 psig). If not alarm 285 will be activated. Pre-lube will provide refrigerant to the compressor bearings from the high side float chamber. Its duration is 10-20 seconds.
COMPRESSOR RUN	Open	Close	Refrigerant pump is continuously on and refrigerant is provided to compressor bearings from high side float chamber.
POST-LUBE	Close	Close	Upon compressor stop a post-lube cycle of 30 seconds is completed before the refrigerant pump is stopped. During post-lube the bearings are supplied with refrigerant from the evaporator.

NOTES:

1. Upon completion of post-lube the chiller is off and the sequence can be started over.
2. Evaporator Control Valve:
Close = source refrigeration pump from high side float chamber
Open = source refrigeration pump from evaporator

3. Condenser Control Valve:
Close = refrigerant pump discharge to compressor bearings
Open = refrigerant pump discharge to high side float chamber

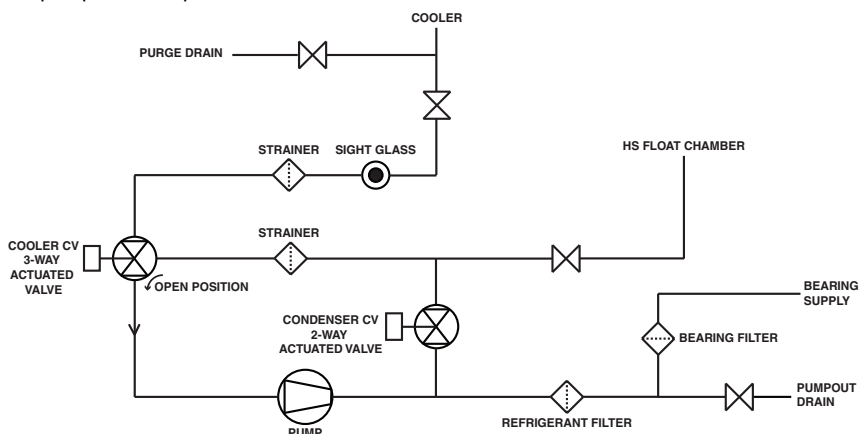

Fig. 16 — Lube Assembly Schematic

Shutdown

The unit can be stopped locally using the HMI by pressing the green Start/Stop icon . The Unit Start/Stop screen is displayed. Press Confirm Stop (see Fig. 17).



Fig. 17 — Confirm Stop

Chiller shutdown begins if any of the following occurs:

- Local OFF button is pressed
- A recycle condition is present

- The time schedule has gone into unoccupied mode when in Network or Local Schedule control mode
- The chiller protective limit has been reached and chiller is in alarm
- The start/stop status (CHIL_S_S) is overridden to stop from the network when in Network mode

If the chiller is normally shut down from running, soft stop shutdown will be performed. The soft stop feature closes the guide vanes of the compressor automatically if a non-alarm stop signal occurs before the compressor motor is de-energized.

Any time the compressor is directed to stop (except in the cases of a fault shutdown), the guide vanes are directed to close and VFD is directed to minimum speed for variable speed compressor, and the compressor shuts off when any of the following is true:

- PERCENT LOAD CURRENT (%) drops below the SOFT STOP AMPS THRESHOLD
- ACTUAL GUIDE VANE OPENING drops below 4%
- 4 minutes have elapsed after initializing stop.

When any one of the above conditions is true, the shutdown sequence stops the compressor by deactivating the compressor start relay. Then the guide vane shall be closed and stay at the fully closed position, the refrigerant pump relay will be turned off after 120 seconds post lube, and the chilled water/brine pump and condenser water pump will be shut down.

BEFORE INITIAL START-UP

Job Data Required

- list of applicable design temperatures and pressures (product data submittal)
- chiller certified prints
- VFD details and wiring diagrams
- diagrams and instructions for special controls or options
- 19DV Installation Instructions

Equipment Required

- mechanic's tools (refrigeration)
- digital volt-ohmmeter (DVM)
- true RMS (root mean square) digital multimeter with clamp-on current probe or true RMS digital clamp-on ammeter rated for at least 480 vac
- electronic refrigerant leak detector
- absolute pressure manometer or electronic micron gage (see Fig. 18)
- drum charging valve (unless refrigerant bottles already have charging valves)
- charging hose



Fig. 18 — Digital Vacuum Gage

Remove Shipping Packaging

Remove any packaging material from the unit, VFD, and control panels. Inspect the unit for damage that occurred during shipping or installation. Document any damage that was identified.

Tighten All Gasketed Joints

Gaskets normally relax by the time the chiller arrives at the job-site. Tighten all gasketed joints to ensure a leak-tight chiller (does not apply to refrigerant joints covered by factory insulation).

Gasketed joints (excluding O-rings) may include joints at some or all of the following:

- Waterbox covers
- Compressor first suction elbow flanges (at compressor and at the evaporator)
- Compressor secondary suction flanges (at compressor and low side float chamber)
- Compressor discharge flange
- Evaporator inlet line spacer (both sides)
- Envelope control flange (both sides of valve)
- ICP piping flange
- High and low side float chamber covers

See Tables 4 and 5 for bolt torque requirements.

Check Chiller Tightness

Figure 19 outlines the proper sequence and procedures for leak testing.

The 19DV chillers are shipped without the refrigerant charge. The chiller is shipped with a 15 psig (103 kPa) dry nitrogen-holding charge.

If the 15 psig factory nitrogen charge is present, then release pressure and proceed to pull a deep vacuum on the unit. Vacuum should be pulled through 1½-in. female NPT located under bottom of first stage side of the evaporator. Upon completion of pulling the required vacuum the chiller can be charged with refrigerant. The ½-in. charging valve on top of the evaporator shell should be used for charging by lifting charge cylinder and gravity feed into the evaporator. The chiller should be charged with refrigerant. If the holding charge is not present, the chiller must be examined for leaks. To test for leaks add a small refrigerant holding charge to unit and pressurize with nitrogen up to 20 psig to determine and correct the origin of the leak. Use an electronic leak detector to check all flanges and solder joints after the chiller is pressurized. If the 15 psig factory nitrogen charge is present, then release pressure and proceed to pull a vacuum on the unit. The chiller should be charged with refrigerant. Follow the leak test chiller procedure (page 22).

If the chiller is spring isolated, keep all springs blocked in both directions to prevent possible piping stress and damage during the transfer of refrigerant from vessel to vessel during the leak test process, or any time refrigerant is being transferred. Adjust the springs when the refrigerant is in operating condition and the water circuits are full. Any piping weights are to be separately supported.

Table 4 — Bolt Torque Requirements, Foot Pounds

BOLT SIZE (in.)	SAE 2, A307 GR A HEX HEAD NO MARKS LOW CARBON STEEL		SAE 5 SOCKET HEAD OR HEX WITH 3 RADIAL LINES, OR SA499 MEDIUM CARBON STEEL		SAE 8 HEX HEAD WITH 6 RADIAL LINES OR SA354 GR BD MEDIUM CARBON STEEL	
	Minimum	Maximum	Minimum	Maximum	Minimum	Maximum
1/4	4	6	6	9	9	13
5/16	8	11	13	18	20	28
3/8	13	19	22	31	32	46
7/16	21	30	35	50	53	75
1/2	32	45	53	75	80	115
9/16	46	65	75	110	115	165
5/8	65	95	105	150	160	225
3/4	105	150	175	250	260	370
7/8	140	200	265	380	415	590
1	210	300	410	580	625	893
1 1/8	330	475	545	780	985	1,410
1 1/4	460	660	770	1,100	1,380	1,960
1 3/8	620	885	1,020	1,460	1,840	2,630
1 1/2	740	1060	1,220	1,750	2,200	3,150
1 5/8	1010	1450	1,670	2,390	3,020	4,310
1 3/4	1320	1890	2,180	3,110	3,930	5,610
1 7/8	1630	2340	2,930	4,190	5,280	7,550
2	1900	2720	3,150	4,500	5,670	8,100
2 1/4	2180	3120	4,550	6,500	8,200	11,710
2 1/2	3070	4380	5,000	7,140	11,350	16,210
2 3/4	5120	7320	8,460	12,090	15,710	22,440
3	6620	9460	11,040	15,770	19,900	28,440

Table 5 — Bolt Torque Requirements, Foot Pounds (Metric Bolts)

BOLT SIZE (Metric)	CLASS 8.8		CLASS 10.9	
	Minimum	Maximum	Minimum	Maximum
M4	1.75	2.5	2.5	3.5
M6	6	9	8	12
M8	14	20	20	30
M10	28	40	40	57
M12	48	70	70	100
M16	118	170	170	240
M20	230	330	330	470
M24	400	570	570	810
M27	580	830	820	1175

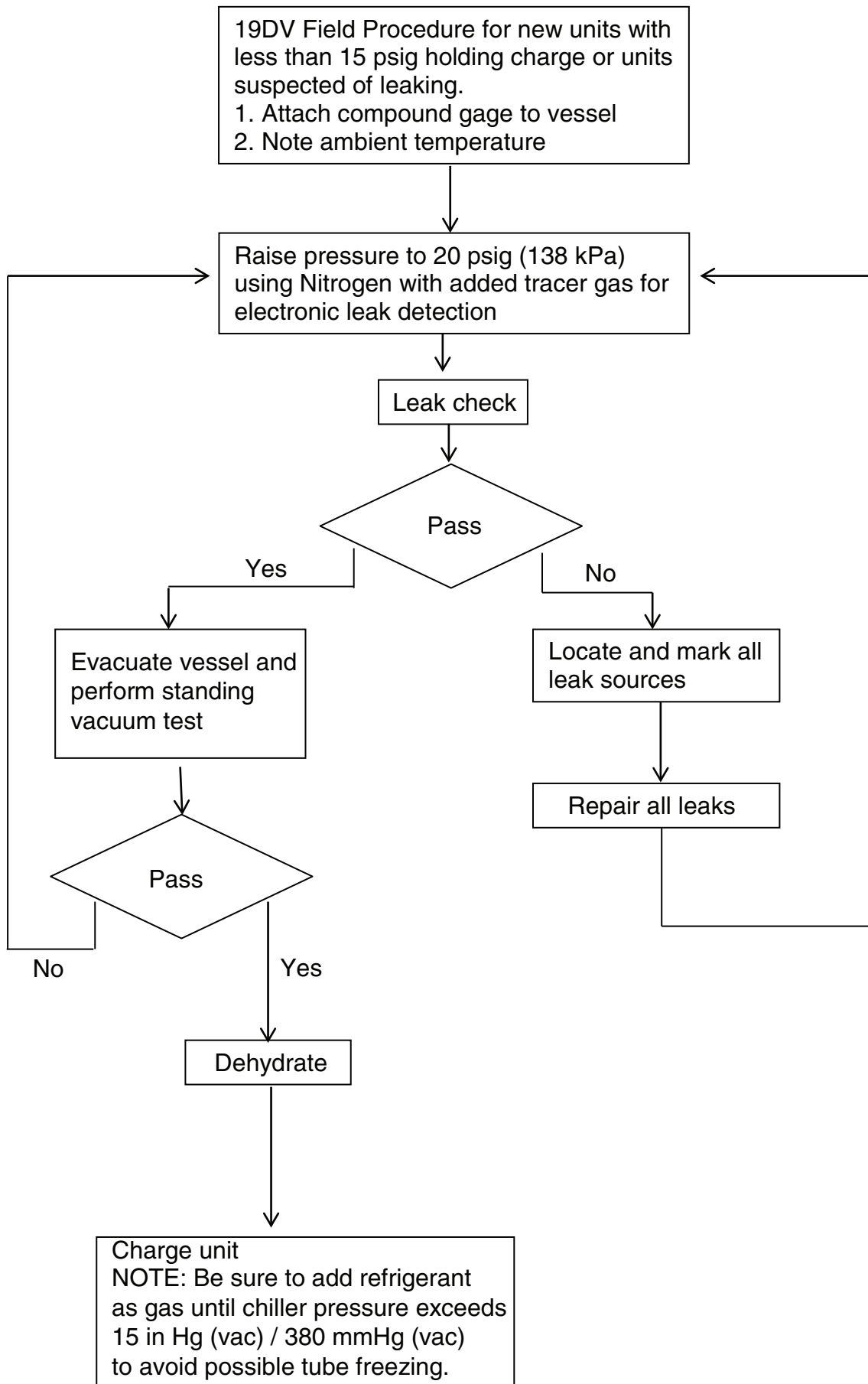

Fig. 19 — 19DV Leak Test Procedures

Refrigerant Tracer

Carrier recommends the use of an environmentally acceptable refrigerant tracer for leak testing with an electronic refrigerant detector.

Ultrasonic leak detectors can also be used if the chiller is under pressure.

WARNING

Do not use air or oxygen as a means of pressurizing the chiller. Mixtures of HFO R-1233zd(E) and air at elevated pressure can undergo combustion, resulting in equipment damage and possible personal injury.

Leak Test Chiller

Due to regulations regarding refrigerant emissions and the difficulties associated with separating contaminants from the refrigerant, Carrier recommends the following leak test procedure. Refer to Table 6 for refrigerant pressure/temperature values.

1. If the pressure readings are normal for the chiller condition:
 - a. Evacuate the charge from the vessels, if present.
 - b. Raise the chiller pressure, if necessary, by adding refrigerant until pressure is at the equivalent saturated pressure for the surrounding temperature.

CAUTION

Never charge liquid refrigerant into the chiller if the pressure in the chiller is less than 15 in. Hg (vac) / 380 mm Hg (vac) for HFO R-1233zd(E). Charge as a gas only, with the evaporator and condenser pumps running, until this pressure is reached, using PUMPDOWN/LOCKOUT (located in the Maintenance menu) and END LOCKOUT mode on the PIC6 control interface. Flashing of liquid refrigerant at low pressures can cause tube freeze-up and considerable damage.

- c. Leak test chiller as outlined in Steps 3 to 7.
2. If the pressure readings are abnormal for the chiller condition:
 - a. Prepare to leak test chiller.
 - b. For cooling machines, check for leaks by connecting a nitrogen bottle with added tracer to allow for electronic leak detection if possible; otherwise, soap bubble solution is to be used. Raise the pressure to 20 psig (138 kPa). If electronic leak detector is available, ensure small amount of tracer material is added.
 - c. Plainly mark any leaks that are found.
 - d. Release the pressure in the system.
 - e. Repair all leaks.
 - f. Retest the joints that were repaired.

NOTE: Suggested test pressure is 20 psig (138 kPa); maximum allowable test pressure 45 psig (310 kPa).

3. Check the chiller carefully with an electronic leak detector or soap bubble solution.
4. Leak Determination — If an electronic leak detector indicates a leak, use a soap bubble solution, if possible, to confirm. Total all leak rates for the entire chiller. Leakage at rates greater than 0.1% of the total charge per year should be repaired. Local regulation governs the requirements for when repair of leaks become mandatory. Note the total chiller leak rate as well as the full charge amount on the start-up report.
5. If no leak is found during the initial start-up procedures, complete the transfer of refrigerant gas from the storage tank to the chiller. Recover any gas used for leak detection purposes as required per local jurisdiction.
6. If no leak is found after a retest:
 - a. Perform a standing vacuum test as outlined in the Standing Vacuum Test section, below.
 - b. If the chiller fails the standing vacuum test, repeat leak test and repair.
 - c. If the chiller passes the standing vacuum test, dehydrate the chiller. Follow the procedure in the Chiller Dehydration section, page 24. Charge the chiller with refrigerant.
7. If the chiller is opened to the atmosphere for an extended period, evacuate it before repeating the leak test. A nitrogen purge should be maintained to reduce the potential for corrosion when open to the atmosphere.

NOTE: Alternate optional leak testing method is to isolate the water circuits and use a portable water heater to raise the temperature of the evaporator and condenser water circuits to approximately 100°F (38°C) which corresponds to a pressure of approximately 14.40 psig (99.3 kPag).

Standing Vacuum Test

When performing the standing vacuum test or chiller dehydration, use a manometer or a wet bulb indicator. Dial gages cannot indicate the small amount of acceptable leakage during a short period of time.

1. Attach an absolute pressure manometer or wet bulb indicator to the chiller.
2. Evacuate the vessel to at least 18 in. Hg vac (41 kPa [abs]), using a vacuum pump or a pumpout unit.
3. Valve off the pump to hold the vacuum and record the manometer or indicator reading.
 - a. If the leakage rate is less than 0.05 in. Hg (0.17 kPa) in 24 hours, the chiller is sufficiently tight.
 - b. If the leakage rate exceeds 0.05 in. Hg (0.17 kPa) in 24 hours, re-pressurize the vessel and test for leaks.
4. Repair the leak, retest, and proceed with dehydration.

Table 6 — HFO R-1233zd(E) Pressure and Temperature

TEMP.		PRESSURE						
F	C	PSIA	PSIG	IN HG	KPAG	KPA ABS	MMHG (VAC)	% VACUUM
20.0	-6.7	5.16	-9.54	-19.4	-65.8	35.6	493.5	65
22.0	-5.6	5.43	-9.27	-18.9	-63.9	37.4	479.4	63
24.0	-4.4	5.72	-8.98	-18.3	-61.9	39.4	464.6	61
26.0	-3.3	6.01	-8.69	-17.7	-59.9	41.5	449.3	59
28.0	-2.2	6.32	-8.38	-17.1	-57.8	43.6	433.3	57
30.0	-1.1	6.64	-8.06	-16.4	-55.6	45.8	416.7	55
32.0	0.0	6.98	-7.72	-15.7	-53.2	48.1	399.3	53
34.0	1.1	7.33	-7.37	-15.0	-50.8	50.5	381.3	50
36.0	2.2	7.69	-7.01	-14.3	-48.3	53.0	362.6	48
38.0	3.3	8.06	-6.64	-13.5	-45.8	55.6	343.2	45
40.0	4.4	8.45	-6.25	-12.7	-43.1	58.3	323.0	42
42.0	5.6	8.86	-5.84	-11.9	-40.3	61.1	302.0	40
44.0	6.7	9.28	-5.42	-11.0	-37.4	64.0	280.2	37
46.0	7.8	9.72	-4.98	-10.1	-34.3	67.0	257.6	34
48.0	8.9	10.17	-4.53	-9.2	-31.2	70.1	234.2	31
50.0	10.0	10.64	-4.06	-8.3	-28.0	73.4	209.9	28
52.0	11.1	11.13	-3.57	-7.3	-24.6	76.7	184.8	24
54.0	12.2	11.63	-3.07	-6.2	-21.2	80.2	158.7	21
56.0	13.3	12.15	-2.55	-5.2	-17.6	83.8	131.7	17
58.0	14.4	12.69	-2.01	-4.1	-13.8	87.5	103.8	14
60.0	15.6	13.25	-1.45	-2.9	-10.0	91.4	74.9	10
62.0	16.7	13.83	-0.87	-1.8	-6.0	95.4	45.0	6
64.0	17.8	14.43	-0.27	-0.6	-1.9	99.5	14.0	2
66.0	18.9	15.05	0.35	0.7	2.4	103.7	—	—
68.0	20.0	15.69	0.99	2.0	6.8	108.1	—	—
70.0	21.1	16.34	1.64	3.3	11.3	112.7	—	—
72.0	22.2	17.03	2.33	4.7	16.0	117.4	—	—
74.0	23.3	17.73	3.03	6.2	20.9	122.2	—	—
76.0	24.4	18.46	3.76	7.6	25.9	127.2	—	—
78.0	25.6	19.20	4.50	9.2	31.1	132.4	—	—
80.0	26.7	19.98	5.28	10.7	36.4	137.7	—	—
82.0	27.8	20.77	6.07	12.4	41.9	143.2	—	—
84.0	28.9	21.59	6.89	14.0	47.5	148.9	—	—
86.0	30.0	22.44	7.74	15.8	53.4	154.7	—	—
88.0	31.1	23.31	8.61	17.5	59.4	160.7	—	—
90.0	32.2	24.21	9.51	19.4	65.6	166.9	—	—
92.0	33.3	25.13	10.43	21.2	71.9	173.3	—	—
94.0	34.4	26.08	11.38	23.2	78.5	179.8	—	—
96.0	35.6	27.06	12.36	25.2	85.2	186.6	—	—
98.0	36.7	28.07	13.37	27.2	92.2	193.5	—	—
100.0	37.8	29.10	14.40	29.3	99.3	200.7	—	—
102.0	38.9	30.17	15.47	31.5	106.7	208.0	—	—
104.0	40.0	31.26	16.56	33.7	114.2	215.5	—	—
106.0	41.1	32.39	17.69	36.0	122.0	223.3	—	—
108.0	42.2	33.54	18.84	38.4	129.9	231.3	—	—
110.0	43.3	34.73	20.03	40.8	138.1	239.5	—	—
112.0	44.4	35.95	21.25	43.3	146.5	247.9	—	—
114.0	45.6	37.20	22.50	45.8	155.1	256.5	—	—
116.0	46.7	38.48	23.78	48.4	164.0	265.3	—	—
118.0	47.8	39.80	25.10	51.1	173.1	274.4	—	—
120.0	48.9	41.16	26.46	53.9	182.4	283.8	—	—
122.0	50.0	42.54	27.84	56.7	192.0	293.3	—	—
124.0	51.1	43.97	29.27	59.6	201.8	303.1	—	—
126.0	52.2	45.42	30.72	62.6	211.8	313.2	—	—
128.0	53.3	46.92	32.22	65.6	222.1	323.5	—	—
130.0	54.4	48.45	33.75	68.7	232.7	334.1	—	—

Check the Installation

Use the following instructions to verify the condition of the installation. Note that the contractor should not apply power to the chiller before the Carrier Start-up Technician arrives at the job site.

1. Inspect the water piping to the chiller to confirm it is correct. Confirm it is adequately supported from the chiller and there are isolation valves installed.
2. Turn off, lock out, and tag the input power to the drive.
3. Wait a minimum of 5 minutes for the DC bus to discharge.
4. All wiring should be installed in conformance with the applicable local, national, and international codes (e.g., NEC/CSA).
5. Remove any debris, such as metal shavings, from the enclosure.
6. Check that there is adequate clearance around the machine.
7. Verify that the wiring to the terminal strip and the power terminals is correct and that no external voltage potential is connected to any of the inputs.
8. Verify that all of the VFD power module circuit board connectors are fully engaged and taped in place.
9. Check that the field-installed wire size is within terminal specifications and that the wires are tightened properly and adequately supported.
10. Check that specified branch circuit protection is installed and correctly rated.
11. Check that the incoming power is within $\pm 10\%$ of chiller nameplate voltage.
12. Verify that a properly sized ground wire is installed and a suitable earth ground is used. Check for and eliminate any grounds between the power leads. Verify that all ground leads are unbroken to the power supply. Only a wye secondary power supply transformer with solidly grounded neutral is acceptable as a power supply to this chiller. If a ground wire is not present or the transformer secondary is any other type than a wye with solidly grounded delta, please contact the Technical Service Manager or Service Engineering.

Inspect Wiring

WARNING

Do not check the voltage supply without proper equipment and precautions. Serious personal injury may result. Follow power company recommendations.

CAUTION

Do not apply any kind of test voltage, even for a rotation check, if the chiller is under a dehydration vacuum. Insulation breakdown and serious damage may result.

WARNING

Do not apply power unless a qualified Carrier technician is present. Serious personal injury may result.

1. Examine the wiring for conformance to the job wiring diagrams and all applicable electrical codes.
2. Ensure that the VFD is protected by fused disconnects or circuit breakers as per electrical code.

3. Compare the ampere rating on the VFD nameplate to rating on the compressor nameplate.
4. Check that there is adequate service clearance around the machine.
5. Check that specified branch circuit protection is installed and correctly rated.
6. Ensure there is capability to turn off, lock out, and tag the input power to the drive.
7. If power is applied to the drive then wait a minimum of 5 minutes for the DC bus to discharge and check DC bus voltage prior to starting any work.
8. Inspect the control panels and VFD enclosure to ensure that the contractor has used the knockouts or provided top hat to feed the wires into the enclosures. Generally, wiring into the top of the enclosures can allow debris to fall into the enclosures. Clean and inspect the interior of the power panel and VFD enclosure if this has occurred. If metal particulate has fallen into the rectifier or inverter assemblies contact Service Engineering or your Technical Service Manager for further instructions.
9. Check that the incoming power is within $\pm 10\%$ of chiller nameplate voltage.
10. Check that the room environmental conditions match the chiller enclosure type.
11. Ensure the customer's contractor has verified proper operation of the pumps, cooling tower fans, and associated auxiliary equipment. This includes ensuring motors are properly lubricated and have proper electrical supply and proper rotation. Carrier must maintain pump control for freeze protection algorithm.
12. Verify that the incoming source does not exceed the SCCR (short circuit current rating) of the equipment marking.
13. Ensure all electrical equipment and controls are properly grounded in accordance with the job drawings, certified drawings, and all applicable electrical codes.

Chiller Dehydration

Dehydration is recommended if the chiller has been open for a considerable period of time, if the chiller is known to contain moisture, or if there has been a complete loss of chiller holding charge or refrigerant pressure.

CAUTION

Do not start or megohm-test the compressor motor or any other pump motor, even for a rotation check, if the chiller is under dehydration vacuum. Insulation breakdown and severe damage may result.

WARNING

Power to the motor and VFD must be disconnected by an isolation switch before placing the machine under a vacuum. To be safe, isolate input power before evacuating the chiller if you are not sure if there are live leads to the hermetic motor.

Dehydration can be done at room temperatures. Using a cold trap (Fig. 20) may substantially reduce the time required to complete the dehydration and is recommended should the unit be exposed to liquid moisture. The higher the room temperature, the faster dehydration takes place. At low room temperatures, a very deep vacuum is required to boil off any moisture and heating of the water in the water circuits of the chiller to approximately 100°F (38°C) may be required.

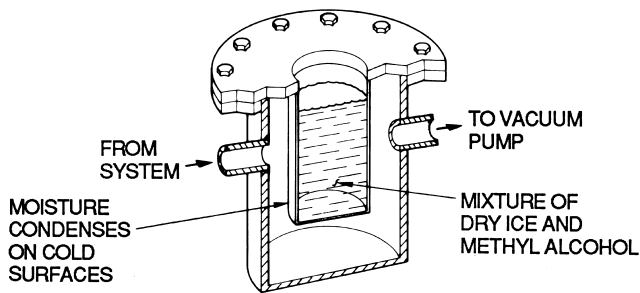

Fig. 20 — Dehydration Cold Trap

Perform dehydration as follows:

1. Connect a high capacity vacuum pump (5 cfm [.002 m³/s] or larger is recommended) to the refrigerant vacuum/charging valve (Fig. 2). Tubing from the pump to the chiller should be as short in length with a minimum diameter of 0.5 in. (13 mm) and as large in diameter as possible to provide least resistance to gas flow.
2. Use an absolute pressure manometer or a electronic micron gage to measure the vacuum. Open the shutoff valve to the vacuum indicator only when taking a reading. Leave the valve open for 3 minutes to allow the indicator vacuum to equalize with the chiller vacuum.
3. If the entire chiller is to be dehydrated, open all isolation valves (if present).
4. With the chiller ambient temperature at 60°F (15.6°C) or higher, operate the vacuum pump until the manometer reads 29.8 in. Hg (vac), -14.63 psig (-100.9 kPag), or a vacuum indicator reads 35°F (1.7°C). Operate the pump an additional 2 hours.
5. Do not apply a greater vacuum than 29.82 in. Hg vac (757.4 mm Hg) or go below 33°F (0.56°C) on the wet bulb vacuum indicator. At this temperature and pressure, isolated pockets of moisture can turn into ice. The slow rate of evaporation (sublimation) of ice at these low temperatures and pressures greatly increases dehydration time.
6. Valve off the vacuum pump, stop the pump, and record the instrument reading.
7. After a 2-hour wait, take another instrument reading. If the reading has not changed, dehydration is complete. If the reading indicates vacuum loss, repeat Steps 4 and 5.
8. If the reading continues to change after several attempts, perform a leak test (maximum 45 psig [310 kPa] pressure). Locate and repair the leak, and repeat dehydration.
9. Once dehydration is complete, the evacuation process can continue. The final vacuum prior to charging the unit with refrigerant should in all cases be 29.9 in. Hg (500 microns, 0.07 kPa [abs]) or less.

Inspect Water Piping

Refer to piping diagrams provided in the certified drawings and the piping instructions in the 19DV Installation Instructions manual. Inspect the piping to the evaporator and condenser. Be sure that the flow directions are correct and that all piping specifications have been met.

Piping systems must be properly vented with no stress on waterbox nozzles and covers. Water flows through the evaporator and condenser must meet job requirements. Measure the pressure drop across the evaporator and the condenser.

CAUTION

Water must be within design limits, clean, and treated to ensure proper chiller performance and to reduce the potential of tube damage due to corrosion, scaling, or erosion. Carrier assumes no responsibility for chiller damage resulting from untreated or improperly treated water.

Check Safety Valves

Be sure safety valves have been piped to the outdoors in compliance with the latest edition of ANSI/ASHRAE Standard 15 and applicable local safety codes. Piping connections must allow for access to the valve mechanism for periodic inspection and leak testing.

The standard 19DV relief devices are set to relieve at 57 psig (393 kPa) chiller design pressure. To avoid potential rupture the chiller should never be pressurized above 45 psig (310 kPa) for any testing purpose.

Check Purge Compressor Operation

Enter Quick Test menu (under Main Menu) and select “Quick Test Purge Comp.” The purge compressor suction temperature (viewed on the Purge System status screen) should be approximately -4.1°F ± 1.1°F (-20.1°C ± 0.6°C). If the purge suction temperature shows differently, the purge expansion valve in the R-134a purge circuit can be adjusted until the reading falls within the range. Clockwise rotation increases the temperature/pressure setting and counterclockwise rotation decreases the temperature/pressure setting. The purge compressor will need to run continuously for a period of time for the temperature to stabilize. The purge system is shown in Fig. 21.

NOTE: This step should only be performed if the purge is not working correctly. The purge suction pressure can be determined by connecting a pressure gauge to the purge compressor inlet Schrader valve (suction is top fitting). This pressure should read between 4 and 5 psig (27.6 to 34.5 kPa). The installation of the gage will result in a loss of refrigerant and the charge of R-134a is a very small quantity affecting the operation of the purge. The charge should be weighed into this circuit using a charging cylinder or similar device. Total R-134a charge is 21 oz ± 1.5 oz (600 g ± 10 g).

NOTE: CLOCKWISE ROTATION OF EXPANSION VALVE ADJUSTMENT SCREW INCREASES THE PRESSURE SETTING AND COUNTERCLOCKWISE ROTATION DECREASES PRESSURE SETTING.

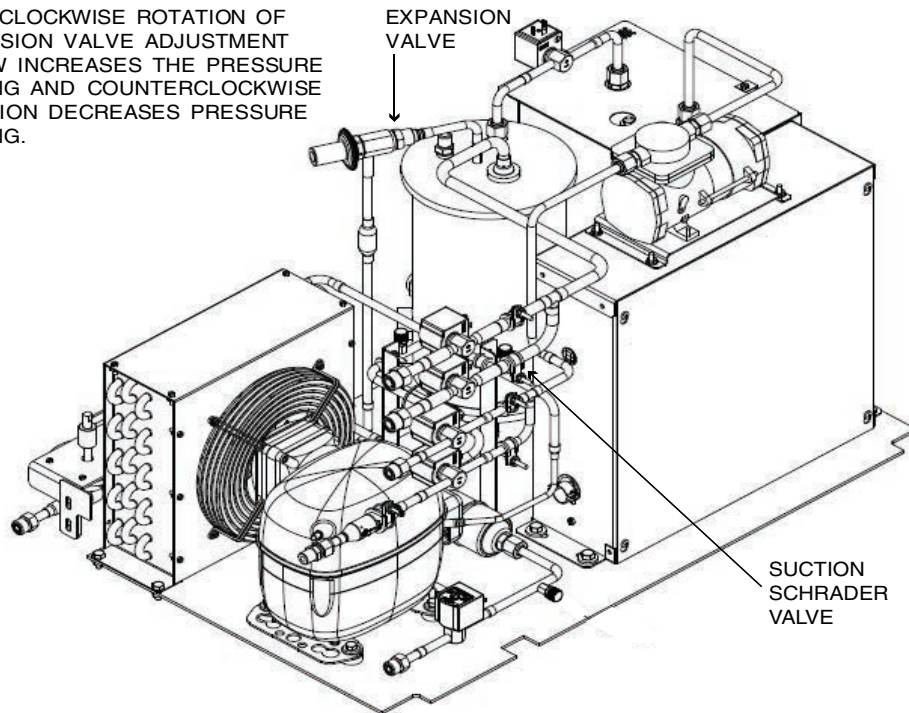

Fig. 21 — Purge System

Ground Fault Troubleshooting

Follow this procedure only if ground faults are declared by the chiller controls. Test the chiller compressor motor and its power lead insulation resistance with a 500-v insulation tester such as a megohmmeter.

1. Open the VFD main disconnect switch and follow lockout/tagout rules.

⚠ CAUTION

The motor leads must be disconnected from the VFD before an insulation test is performed. The voltage generated from the tester can damage the VFD.

2. Perform test #1: For 3-lead motor, tie terminals 1, 2, and 3 together and test between the group and ground.
 - a. With the tester connected to the motor leads, take 10-second and 60-second megohm readings.
 - b. Divide the 60-second resistance reading by the 10-second reading. The ratio, or polarization index, must be one or higher. Both the 10 and 60-second readings must be at least 50 megohms. If the readings are unsatisfactory, repeat the test at the motor with the power leads disconnected. Satisfactory readings in this second test indicate the fault is in the power leads.
3. Perform test #2: Only perform this test if the unit has been disassembled at the job site, if the starter has been removed, or during annual maintenance. Perform a megohm test from each terminal to ground. The megohm value should be greater than 20 megohm. Note that if a megohm test is performed between the terminals it will show a direct short and is not a valid test because of the 3 terminal motor internal delta configuration.

Carrier Comfort Network Interface

The Carrier Comfort Network® (CCN) communication bus wiring is supplied and installed by the electrical contractor. It consists of shielded, 3-conductor cable with drain wire.

The system elements are connected to the communication bus in a daisy chain arrangement. The positive pin of each system element communication connector must be wired to the positive pins of the system element on either side of it. The negative pins must be wired to the negative pins. The signal ground pins must be wired to the signal ground pins. See installation manual.

NOTE: Conductors and drain wire must be 20 AWG (American Wire Gage) minimum stranded, tinned copper. Individual conductors must be insulated with PVC, PVC/nylon, vinyl, Teflon¹, or polyethylene. An aluminum/polyester 100% foil shield and an outer jacket of PVC, PVC/nylon, chrome vinyl, or Teflon with a minimum operating temperature range of -4°F to 140°F (-20°C to 60°C) is required. See Table 7 for cables that meet the requirements.

Table 7 — Manufacturers and Cable Numbers

Manufacturer	Cable No.
ALPHA	2413 or 5643
AMERICAN	A22503
BELDEN	8772
COLUMBIA	02525

When connecting the CCN communication bus to a system element, a color code system for the entire network is recommended to simplify installation and checkout. The color code shown in Table 8 is recommended.

Table 8 — Recommended Color Code

SIGNAL TYPE	CCN BUS CONDUCTOR INSULATION COLOR	CCN TERMINAL CONNECTION
+	Red	Red (+)
GROUND	White	White (G)
-	Black	Black (-)

1. Teflon is a registered trademark of DuPont.

⚠ WARNING

BE AWARE that certain automatic start arrangements *can engage the starter*. Open the disconnect *ahead* of the starter in addition to shutting off the chiller or pump. Failure to follow this procedure may result in personal injury by electric shock.

⚠ WARNING

The main disconnect on the starter front panel may not de-energize all internal circuits. Open all internal and remote disconnects before servicing the starter. Failure to follow this procedure may result in personal injury by electric shock.

Inhibitor Charge

The inhibitor charge is included with the 19DV unit supplied from the factory. No action associated with inhibitor is required unless a new refrigerant charge is added or the inhibitor has been distilled out of the existing refrigerant charge. See Tables 9 and 10 for refrigerant charge weights.

If the unit needs to be disassembled, add 1% (mass of total refrigerant charge) of inhibitor PP23BZ110001 (part number is for 1 Gal. Inhibitor Density is 8.2202 lb/Gal [0.985 Kg/L]). For example, see Table 10; sum up the evaporator, condenser, and economizer charge; take 1% of total charge; then calculate required inhibitor volume. For a G20 evaporator with G22 condenser this yields: $(700+413+342)\text{lb} \times 0.01 / (8.2202 \text{ lb/Gal}) = 1.77 \text{ Gal}$ (1 Gal + 99 oz) [6.70 L]. See Fig. 22 for field inhibitor addition assuming compressor running and negative evaporator pressure. A dose of Carrier inhibitor is supplied with the unit by the factory.

Suggested Procedure:

1. Ensure availability of appropriate PPE such as protective gloves/protective clothing/eye protection/face protection and wash thoroughly after handling.
2. If new inhibitor charge is required, a refrigerant charge hose can be used for this purpose or a hard pipe creating a funnel using a 90 degree 2-in. x 1/2-in. NPT female elbow reducer along with a 2-in. NPT pipe to create a reservoir (add inhibitor as it is being sucked into the evaporator and close 1/2-in. charging ball valve prior to air being sucked into chiller). Ensure that parts used to add inhibitor are clean to avoid any chiller contamination.

Table 9 — Frame F DV3 Heat Exchangers Refrigerant Charge*

FRAME AND BUNDLE SIZE	EVAPORATOR REFRIGERANT WEIGHTS (lb)	CONDENSER REFRIGERANT WEIGHTS (lb)	FRAME AND BUNDLE SIZE	EVAPORATOR REFRIGERANT WEIGHTS (kg)	CONDENSER REFRIGERANT WEIGHTS (kg)
F20, F25	570	—	F20, F25	1257	—
F21, F26	577	—	F21, F26	1272	—
F22, F27	586	311	F22, F27	1292	686
F23, F28	595	319	F23, F28	1312	703
F24, F29	605	326	F24, F29	1334	719
F40, F45	653	—	F40, F45	1440	—
F41, F46	660	—	F41, F46	1455	—
F42, F47	671	386	F42, F47	1479	851
F43, F48	682	395	F43, F48	1504	871
F44, F49	693	403	F44, F49	1528	888
F2A, F2F	543	—	F2A, F2F	1197	—
F2B, F2G	549	—	F2B, F2G	1210	—
F2C, F2H	554	288	F2C, F2H	1221	635
F2D, F2J	560	292	F2D, F2J	1235	644
F2E, F2K	566	298	F2E, F2K	1248	657
F4A, F4F	621	—	F4A, F4F	1369	—
F4B, F4G	628	—	F4B, F4G	1385	—
F4C, F4H	634	349	F4C, F4H	1398	769
F4D, F4J	641	354	F4D, F4J	1413	780
F4E, F4K	648	361	F4E, F4K	1429	796

* The economizer refrigerant weight for Frame F is 227 lbs, so for example the charge for an F22 evaporator with an F28 condenser is 586 lbs + 319 lbs + 227 lbs = 1132 lbs.
The economizer refrigerant weight for Frame F is 103 kg, so for example the charge for an F22 evaporator with an F28 condenser is 144 kg + 85 kg + 103 kg = 332 kg.

Table 10 — DV4 Refrigerant Charge*

G				H			
EVAPORATOR HX	REFRIGERANT WT lbs (kg)	CONDENSER	REFRIGERANT WT lbs (kg)	EVAPORATOR HX	REFRIGERANT WT lbs (kg)	CONDENSER	REFRIGERANT WT lbs (kg)
G20 through G2K	700 (318)	G22, G27, G2C, G2H	413 (187)	H20, H25	741 (336)	H22, H27	484 (220)
G40 through G4K	840 (381)	G23, G28, G2D, G2J	405 (184)	H21, H26	752 (341)	H23, H28	495 (225)
—	—	G24, G29	402 (182)	H22, H27	763 (346)	H24, H29	507 (230)
—	—	G2E, G2K	397 (180)	H23, H28	778 (353)	H2C, H2H	431 (195)
—	—	G42, G47, G4C, G4H	468 (212)	H24, H29	792 (359)	H2D, H2J	439 (199)
—	—	G43, G48, G4D, G4J	458 (208)	H2A, H2F	700 (318)	H2E, H2K	448 (203)
—	—	G44, G49	455 (206)	H2B, H2G	707 (321)	H42, H47	563 (255)
—	—	G4E, G4K	448 (203)	H2C, H2H	716 (325)	H43, H48	576 (261)
—	—	—	—	H2D, H2J	726 (329)	H44, H49	590 (268)
—	—	—	—	H2E, H2K	736 (334)	H4C, H4H	499 (226)
—	—	—	—	H40, H45	841 (381)	H4D, H4J	508 (230)
—	—	—	—	H41, H46	853 (387)	H4E, H4K	518 (235)
—	—	—	—	H42, H47	866 (393)	—	—
—	—	—	—	H43, H48	883 (401)	—	—
—	—	—	—	H44, H49	900 (408)	—	—
—	—	—	—	H4A, H4F	795 (361)	—	—
—	—	—	—	H4B, H4G	803 (364)	—	—
—	—	—	—	H4C, H4H	813 (369)	—	—
—	—	—	—	H4D, H4J	824 (374)	—	—
—	—	—	—	H4E, H4K	836 (379)	—	—

* The economizer refrigerant weight for Frame G, H is 342 lbs, so for example the charge for a G20 evaporator coupled with G22 condenser is 700 lbs + 413 lbs + 342 lbs = 1455 lbs.
The economizer refrigerant weight for Frame G, H is 155 kg, so for example the charge for a G20 evaporator coupled with G22 condenser is 318 kg + 187 kg + 155 kg = 660 kg.

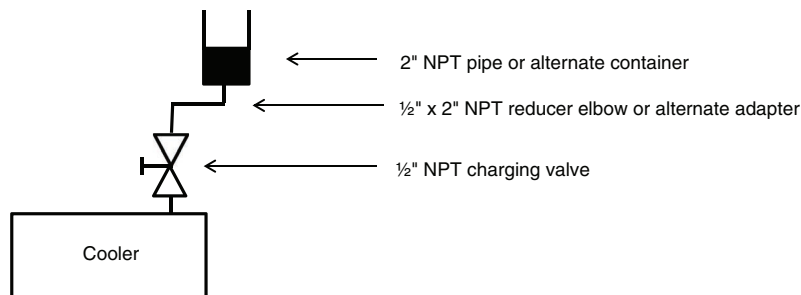

Fig. 22 — Inhibitor Addition

Software Configuration

⚠ WARNING

Do not operate the chiller before the control configurations have been checked and a Calibration and Control Test has been satisfactorily completed. Protection by safety controls cannot be assumed until all control configurations have been confirmed.

See the 19DV with PIC6 Controls Operation and Troubleshooting manual for instructions on using the PIC6 interface to configure the 19DV unit. As the unit is configured, all configuration settings should be written down. A log, such as the one shown starting on page CL-1, provides a list for configuration values.

Charge Unit with Refrigerant

IMPORTANT: Turn on the chilled water and condenser water pumps to prevent freezing.

⚠ CAUTION

Always operate the condenser and chilled water pumps whenever charging, transferring, or removing refrigerant from the chiller. Always confirm that water flow is established. Failure to follow this procedure may result in equipment damage.

⚠ CAUTION

The transfer, addition, or removal of refrigerant in spring isolated chillers may place severe stress on external piping if springs have not been blocked in both up and down directions. Failure to block springs in both up and down directions could result in severe personal injury and equipment damage.

⚠ CAUTION

Always operate the condenser and chilled water pumps during charging operations to prevent freeze-ups. Damage could result to equipment if condenser and chilled water pumps are not operated during pumpdown or charging.

⚠ WARNING

Always charge refrigerant gas into unit until pressure exceeds water freeze temperature using PUMPDOWN/LOCKOUT (located in the Maintenance menu) and TERMINATE LOCKOUT mode on the PIC6. Evaporator and condenser water pumps must be running to prevent tube freezing.

For R-1233zd(E) water freeze point is exceeded at -15 in. Hg (-51 kPa).

All 19DV units are field charged. Charge the unit from refrigerant cylinders. Use Table 10 to find expected approximate charge by adding evaporator and condenser charge together. Refer to unit nameplate and E-Cat output for certified values.

Prior to charging ensure the following:

1. Standing vacuum test completed.
2. Only initiate refrigerant charging into a deep vacuum.
3. Adequate refrigerant supply available as per unit nameplate.

⚠ CAUTION

Do not apply power to the VFD or motor when in a dehydration vacuum because it will result in equipment damage.

With water pumps running, connect charging hose from refrigerant cylinder to chiller evaporator charging valve. Start with charging gas until the pressure is greater than the above saturation pressure temperature to avoid refrigerant flashing and potential tube freezing. Once required pressure is reached, switch over to charge liquid either by lifting refrigerant cylinder above charging valve to allow for gravity feed or, if charge is isolated in storage tank, by using pumpout equipment suited for low pressure refrigerant. If chilled water is available it may be circulated through the cooler to lower the refrigerant pressure and thereby decrease charging time.

After the machine has been started, adjust charge for optimum machine performance. Operate the chiller at design load and then add or remove refrigerant slowly until the difference between the leaving chilled water temperature and the evaporator refrigerant temperature reaches design conditions or becomes a minimum. Do not overcharge.

Use the evaporator sight glass (see Fig. 23) to determine the correct refrigerant. During steady state operation at full load, the boiling pool tubes under compressor suction should be covered with liquid refrigerant. There is no benefit to a refrigerant liquid level higher than the tubes.

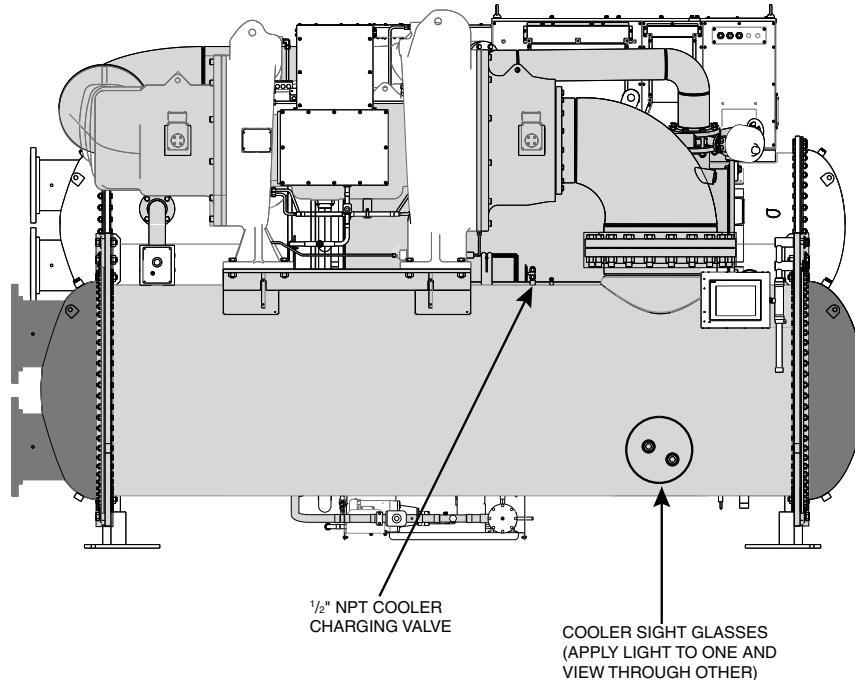



Fig. 23 — Evaporator Charging Valve and Sight Glasses

HOME SCREEN

The home screen is the first screen shown after switching the unit on. See Fig. 24. Note the Globe  and Lock  icons.

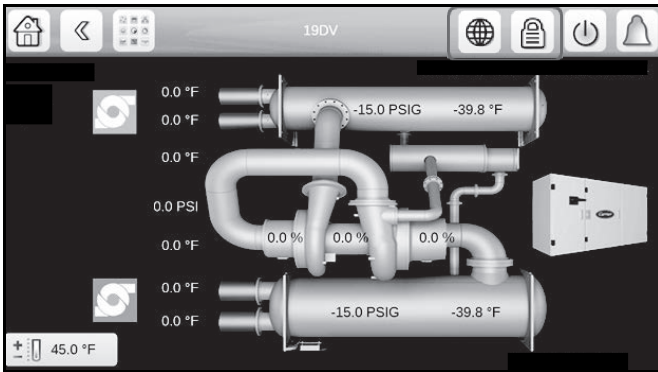

Fig. 24 — Home Screen

The Globe icon  on the Home screen allows access to language and measurement settings. See Fig. 25.



Fig. 25 — Language and Units Selection Screen

The Lock icon  on the Home screen allows access to the password menu and displays current software version. See Fig. 26.



Fig. 26 — Login Screen

CHANGE THE SET POINTS

To access the set point screen, press the lock icon on the Main Menu. In the User Login menu, enter the password (default USER password = 1111), and click accept. The screen will then default back to the home screen. See Fig. 27. The Service Login access is reserved for access to equipment service tables.

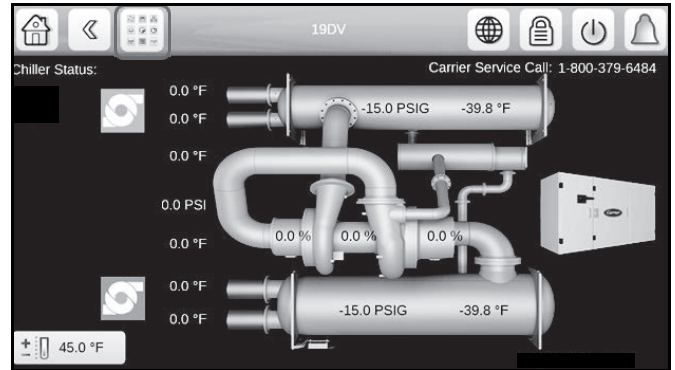

Fig. 27 — Home Screen

The Main Menu screen is displayed. See Fig. 28. Press the Setpoint Table icon.

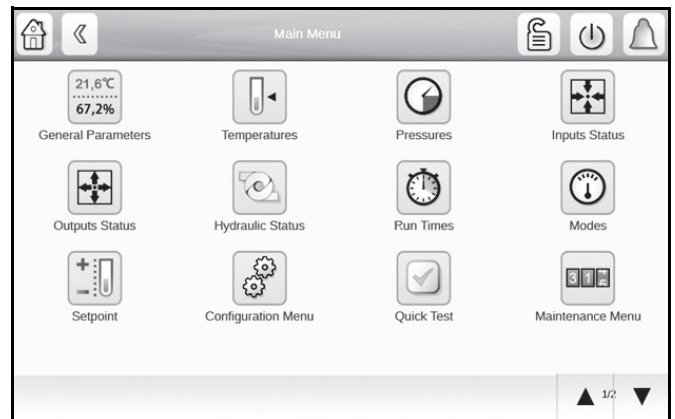

Fig. 28 — Main Menu

The Setpoint screen is displayed. See Fig. 29. Set the base demand limit, and either the LCW set point or the ECW set point. To set a value, press the appropriate set point, enter the value, and press OK. For more information, see the PIC6 Control User Manual.

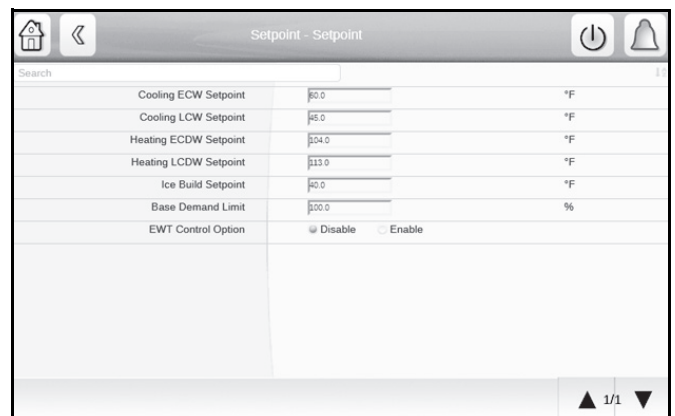

Fig. 29 — Setpoint Menu

INPUT THE LOCAL OCCUPIED SCHEDULE

Access the schedule menu (**Main Menu**→**Configuration Menu**→**Schedule Menu**) and set up the occupied time schedule according to the customer's requirements. If no schedule is available, the default is factory set for 24 hours occupied, 7 days per week including holidays. When the control mode is LOCAL SCHEDULE, the chiller will be automatically started if the configured local schedule is occupied and will be automatically shut down by the unoccupied schedule.

The Network Schedule should be configured if a CCN system is being installed. When control mode is NETWORK, the chiller can be started and stopped by the CHIL_S_S software point as written by other equipment through the network command and network schedule. The Schedule Menu contains a table to set the Network Schedule if required.

For more information about setting time schedules, please refer to the PIC6 Control User Manual.

INPUT SERVICE CONFIGURATIONS

See Fig. 30 for 19DV Configuration Tables. For specific values for the following configurations, refer to the chiller performance data or job-specific data sheet:

1. Password
2. Log in/log out
3. Input time and date
4. Service parameters
5. Equipment configuration
6. Automated control quick test



Fig. 30 — 19DV Configuration Tables

PASSWORD

The PIC6 provides a smart factory password for better security and the password changes periodically. With a smart password, only authorized users can log into the controller factory tables to access key product configuration and maintenance data.

A password must be entered to access the Set Point or other common user tables. See Fig. 31. User password can be changed from the General Configuration Menu. USER CONFIGURATION allows change of the User access password. The default User password is 1111.

IMPORTANT: Be sure to remember the password. Retain a copy for future reference. Without the user password, access will not be possible unless accessed by a Carrier representative. Factory password is required to enter configuration menus required for chiller setup.



Fig. 31 — 19DV Config Tables

INPUT TIME AND DATE

Set day and time and, if applicable, holidays through MAIN MENU SYSTEM CONFIGURATION and then select Date/Time Configuration. See the Controls Operation and Troubleshooting guide for details. Because a schedule is integral to the chiller control sequence, the chiller will not start until the time and date have been set.

MODIFY CONTROLLER IDENTIFICATION IF NECESSARY

The CCN address can be changed from the Configuration Menu. Change this address under CONTROL IDENTIFICATION for each chiller if there is more than one chiller at the jobsite. Write the new address on the PIC6 Touch Screen module for future reference.

CONFIGURE TABLES

Access the related tables through MAIN MENU CONFIGURATION MENU (Fig. 30) to modify or view job site parameters shown in 19DV Configuration tables. Tables 11-17 should be verified or configured during startup/commissioning. Consult chiller nameplates as indicated.

Table 11 — Factory Parameters

DESCRIPTION	RANGE	UNITS	DEFAULT	VALUE
Chiller Type 19XR6/7=0, 19XR2-E/D/V=1, 19DV=2	0 to 2		0	2
VFD Option No=0 FS VFD=1 Carrier=2 Rockwell LF2=3 Eaton=4 Rockwell STD=5 Danfoss=7 Benshaw=8	0 to 8		0	2
Unit Type Cool Only=0, Heat Mach=1	0 to 1		0	Per selection
Comp (Single=0, Dual=1)	0 to 1		1	1
Chilled Medium Type Water/Brine	Water/Brine		Water	Per selection
19DV Comp Design Press 44PSI=0, 72PSI=1	0 to 1		0	1
Country Code	0 to 999		86	01
IOB3 Option (19XR2~E/D/V)	0 to 1		0	n/a
IOB4 Option	No/Yes		No	Yes
Guide Vane1 Type, Digital=0, Analog=1	0 to 1		0	1
Free Cooling Option	No/Yes		No	Per selection
Marine Option	0 to 1		0	n/a
Power Request Option	0 to 1		0	n/a
Cont. Power Request	0 to 1		0	n/a

Table 12 — Service Parameters Table
Menu→Configuration Menu→Service Parameters [SERVICE1]

DESCRIPTION	RANGE	UNITS	DEFAULT	VALUE*
Atmospheric Pressure	8 to 15	PSI	14.5	Per jobsite (if high elevation)
GV1 Travel Limit	30 to 100	%	80.7	Per jobsite (default is typical)
GV1 Closure at Startup	0 to 40	%	4	4
Maximum GV Movement	1 to 4	%	2	2
Controlled Fluid DB	0.5 to 2	^F	1	1
Derivative EWT Gain	1 to 3	—	2	2
Proportional Dec Band	2 to 10	—	6	6
Proportional Inc Band	2 to 10	—	6.5	6.5
Demand Limit At 20 mA	10 to 100	%	40	Option - jobsite specific
Demand Limit Prop Band	3 to 15	%	10	10
Amps or KW Ramp per Min	5 to 20	%	5	5
Temp Ramp per Min	1 to 10	^F	3	Option - jobsite specific
Recycle Shutdown Delta T	0.5 to 4	^F	1	Option - jobsite specific
Recycle Restart Delta T	2 to 10	^F	5	Option - jobsite specific
Lub Press Verify Time	15 to 300	sec	180	Option - jobsite specific
Water Flow Verify Time	0.5 to 5	min	5	5
Soft Stop Amps Threshold	40 to 100	%	70	70
Power Calibration Factor	0.5 to 2	—	1	1
Enable Excessive Starts	No/Yes	—	No	No

* Most Service Parameters do not require any change from default. Adjust as required.

Table 13 — Surge Correction Config

DESCRIPTION	RANGE	UNITS	DEFAULT	VALUE
Surge Line Configuration PR=0, Delta T=1	0 to 1	—	0	Nameplate
IGV1 Pos Configuration Degree=0, Percentage=1	0 to 1	—	0	Nameplate
Surge Delta Tmax	0.0 to 150.0	^F	70	Nameplate
Surge Delta Tmin	0.0 to 150.0	^F	45	Nameplate
PR at Full Load Opening	1.0000 to 5.0000	—	3	Nameplate
PR at Minimum Opening	1.0000 to 5.0000	—	1.5	Nameplate
IGV1 Minimum Position	0 to 100	%	5	5
IGV1 Full Load Position	0.0 to 100.0	%	100	93.6
Surge Line Offset	1.0 to 3.0	^F	1.5	1.5
Surge Line Lower Deadband	0.5 to 3.0	^F	1.0	1.0
Surge Line Upper Deadband	0.1 to 3.0	^F	1.0	1.0
Surge Line Shape Factor	-1.000 to 0.000	—	-0.01	Nameplate
Sound Line Shape Factor	0.000 to 1.000	—	0.01	Nameplate
Envelop Speed Factor	0.00 to 3.00	—	2	Nameplate
Surge Delay Time	0 to 120	sec	15	15
Surge Time Period	7 to 10	min	8	8
Surge Delta Amps %	5.0 to 40.0	%	20	20
Rampdown Factor	0 to 1	—	0.1	0.1
GV1 Close Step Surge	1.0 to 3.0	%	2	2
VFD Speed Step Surge	1.0 to 5.0	%	1.5	1.5
EC Valve Step Surge	1.0 to 10.0	%	4	4
Surge Profile Step	0 to 2	^F	1	1
Surge Profile Offset	0.00 to 5.0	^F	0	0
High Efficiency Mode	Dsable/Enable	—	Enable	Enable
GV Jumpover Option	Disable/Enable	—	Disable	Disable

Table 14 — Option Configuration
Main Menu → Configuration Menu → Option Configuration [CONF_OPT]

DESCRIPTION	RANGE	UNITS	DEFAULT	VALUE
Auto Restart Option	Dsable/Enable	—	Dsable	Jobsite specific
Common Sensor Option	Dsable/Enable	—	Dsable	Jobsite specific
EC Valve Option No=0, Cont.=1, ON/OFF=2, mA=3	0 to 3	—	0	3 (if selected)
EC Valve Selection Disable=0, Surge=1, Low Load=2, Comb=3	0 to 3	—	0	Jobsite specific
ECV Open IGV1 Position	0.5 to 10.0	%	5	5 (adjust as required)
ECV Close IGV1 Position	1.5 to 20.0	%	10	10 (adjust as required)
ECV Off DT for Low Load	0.5 to 10	^F	4	4 (adjust as required)
ECV On DT for Low Load	0.5 to 10	^F	2	2 (adjust as required)
ECV Low Load DB	0.5 to 2.0	^F	1	1 (adjust as required)
Head Pres Valve Option	Dsable/Enable	—	Dsable	Jobsite specific
Head Pres Delta P 0%	20 to 85	PSI	25	25 (adjust as required)
Head Pres Delta P 100%	20 to 85	PSI	50	50 (adjust as required)
Head Pressure Min Output	0 to 100	%	0	0 (adjust as required)
Head Pressure Deadband	0 to 10	PSIG	1	1 (adjust as required)
Tower Fan High Setpoint	55 to 105	°F	75	75 (adjust as required)
Refrig Leakage Option	Dsable/Enable	—	Dsable	Jobsite specific
Refrig Leakage Alarm mA	4 to 20	mA	20	20 (adjust as required)
Guide Vane/SRD Factor	0.70 to 1.20	—	0.95	0.95
Customer Alert Option	Dsable/Enable	—	Dsable	Jobsite specific
Ice Build Option	Dsable/Enable	—	Dsable	Jobsite specific
Ice Build Recycle	Dsable/Enable	—	Dsable	Jobsite specific
Ice Build Termin Source Temp=0, Contact=1, Both=2	0 to 2	—	0	Jobsite specific
Water Pressure Option No=0, Pres.=1, Pres.D=2	0 to 2	—	0	Jobsite specific
Water Flow Measurement No=0, Flow Meter=1, Water Pres. D=2	0 to 2	—	0	Jobsite specific
Water Flow Determination Sat Temp=0, Flow Switch=1	0 to 1	—	0	Jobsite specific
Evap Liquid Temp Opt	Dsable/Enable	—	Enable	n/a
Evap App Calc Selection Sat Temp=0, Ref Temp=1	0 to 1	—	1	1
Remote Stop Contact	Dsable/Enable	—	Disable	Disable

Table 15 — Unit Mounted VFD
Main Menu→Configuration Menu→Unit Mounted VFD [CFGUMVFD]

DESCRIPTION	RANGE	UNITS	DEFAULT	VALUE
Compressor Speed 100%	47 to 110	Hz	50	Nameplate
Rated Line Voltage	200 to 13800	Volts	460	Nameplate
Motor Nameplate Current	10 to 1500	AMPS	200	Nameplate
Motor Rated Load Current	10 to 2000	AMPS	200	Nameplate
Motor Nameplate Voltage	200 to 13800	Volts	460	Nameplate
Motor Nameplate KW	0 to 5600	KW	1500	Nameplate
Skip Frequency 1	0.0 to 102.0	Hz	30	30
Skip Frequency 2	0.0 to 102.0	Hz	30	30
Skip Frequency 3	0.0 to 102.0	Hz	30	30
Skip Frequency Band	0.0 to 102.0	Hz	0	0
Increase Ramp Time	5 to 60	sec	30	30
Decrease Ramp Time	5 to 60	sec	30	30
Line Voltage Imbalance%	1 to 10	%	10	10
Line Volt Imbalance Time	1 to 10	sec	10	10
Line Current Imbalance%	5 to 40	%	40	40
Line Current Imbal Time	1 to 10	sec	10	10
Motor Current Imbalance%	5 to 40	%	40	40
Motor Current Imbal Time	1 to 10	sec	10	10
Single Cycle Dropout	Disable/Enable	—	Disable	Disable
PWM Switch Frequency 0=2 KHZ, 1=4 KHZ	0 to 1	—	0	1

Table 16 — 19DV Configuration
Main Menu→Configuration Menu→19DV [Table = CFG_19DV]

DESCRIPTION	RANGE	UNITS	DEFAULT	VALUE
Pressure Sensor Option Tianmu=0 Texas=1 Sensata=2	0 to 2	—	0	1
Purge System Option	Disable/Enable	—	Disable	Enable
Purge Active Temp SP	30 to 300	Degree	65	65
Purge On Idle Option	Disable	Enable	—	Enable
Purge Regen Lasting Time	0 to 65535	minutes	120	120
Purge Discharge Temp	no range	Degree	8	8
Purge Drainage Temp	no range	Degree	9	9
Purge Discharge Time	0 to 65535	sec	5	5
PG Discharge Delay Time	0 to 65535	sec	30	30
PG Discharge Wait Time	0 to 40	min	1	1
Daily PG Pumpout Limit	20 to 200	min	50	50
Motor Pole Pair	1, 2	—	1	1
IGV2 Travel Limit	30 to 100%	%	96	93.6
IGV2 Minimum Degree	0 to 20	Degree	2	2
IGV2 Full Load Open Degree	10 to 100	Degree	90	88
IGV2 Actuator Max Deg.	90 to 120	Degree	94	94
IGV2 Deg@IGV1 20 Deg	10 to 30	Degree	28.1	28.1
IGV2 Deg@IGV1 30 Deg	10 to 50	Degree	37.2	37.2
IGV2 Deg@IGV1 50 Deg	10 to 80	Degree	71.6	71.6
Comp Based Speed Hz	10 to 200	Hz	80.5	19DV3=110; 19DV4=88
Liquid Bypass Option	Disable/Enable	—	—	Disable, per job requirement
4-valve lube (Legacy DV4)	Disable/Enable	—	Disable	Disable
Pre Lube from Colder HX	Disable/Enable	—	Disable	Disable

Table 17 — General VFD Config
Main Menu→Configuration Menu→General VFD [CFGGEVFD]

DESCRIPTION	RANGE	UNITS	DEFAULT	VALUE
VFD Gain	0.10 to 1.50	—	0.75	0.75
VFD Max Speed Per	90.0 to 110.0	%	100	100
VFD Min Speed Per	45.0 to 89.0	%	70	60
VFD Start Speed Per	65.0 to 100.0	%	100	100
VFD Current Limit	0.0 to 99999.0	AMPS	250	Nameplate

Field Set Up and Verification

IMPORTANT: Some parameters are specific to the chiller configuration and will need to be verified prior to operation. All command functions must be initiated from the HMI.

Use the HMI touch screen to confirm that the VFD values match the chiller parameter labels and Chiller Builder design data sheet. The VFD values can be located from *Main Menu* → *Configuration Menu*.

LABEL LOCATIONS

Verify the following labels have been installed properly and match the chiller requisition:

- Surge Parameters — Located inside the HMI chiller control panel.
- Chiller identification nameplate — Located on the left side of the control panel. See Fig. 32.
- VFD Nameplate data - located on the right side of the VFD. See Fig. 32.

MODIFY EQUIPMENT CONFIGURATION IF NECESSARY

The EQUIPMENT SERVICE table has screens to select, view, or modify parameters. Carrier's certified drawings have the configuration values required for the jobsite. Modify these values only if requested. Modifications can include:

- Chilled water reset
- Entering chilled water control (Enable/Disable)
- 4 to 20 mA demand limit
- Auto restart option (Enable/Disable)
- Remote contact option (Enable/Disable)

See the 19DV with PIC6 Controls Operation and Troubleshooting guide for more details about these functions; see the Control Panel Schematic for field wiring.

Perform a Controls Test (Quick Calibration/Quick Test)

NOTE: The QUICK TEST screens can only be accessed when the chiller is in STOP mode.

Check the safety controls status by performing an automated controls test. First, perform a Quick Calibration Test (Path *Main Menu* → *Quick Calibration*). This is required for all modulating analog actuators. Upon successful calibration, use Quick Test (*Main Menu* → *Quick Test*) to verify operation on desired components. Note that this is a very useful feature for troubleshooting. On the QUICK TEST table screen, select a test to be performed. Note the additional 19DV Quick Test table with additional Quick Test points.

The Quick Test checks all outputs and inputs for proper functionality. In order to successfully proceed with the controls test, the compressor must be off with no alarms showing, and voltage should be within $\pm 10\%$ of rating plate value. Each test asks the operator to confirm the operation is occurring and whether or not to continue. If an error occurs, the operator can try to address the problem as the test is being done or note the problem and proceed to the next test.

NOTE: The refrigerant pump test will not energize the pump if evaporator pressure is below -13 psig (-90 kPa).

When the controls test is finished the test stops and the QUICK TEST menu displays. If a specific automated test procedure is not completed, access the particular control test to test the function when ready. Disable the Quick Test feature when testing is complete. For information about calibration, see the sections Checking Pressure Transducers, page 54, and High Altitude Locations, page 55.

EVAPORATOR AND CONDENSER PRESSURE TRANSDUCER AND WATERSIDE FLOW DEVICE CALIBRATION

The waterside device is optional, with IOB inputs available. Calibration can be checked by comparing the pressure readings from the transducer to an accurate refrigeration gage reading. The transducer can be checked and calibrated at 2 pressure points. These calibration points are 0 psig (0 kPa) and between 10 psig (68.9 kPa) and 30 psig (206.8 kPa). To calibrate these transducers:

1. Shut down the compressor and the evaporator and condenser pumps.
2. Disconnect the transducer in question from its Schrader fitting for evaporator or condenser transducer calibration. For pump pressure or bearing pressure or flow device calibration keep transducer in place.

NOTE: If the evaporator or condenser vessels are at 0 psig (0 kPa) atmospheric pressure, the transducers can be calibrated for zero without removing the transducer from the vessel.

3. Access the PRESSURE screen from the Main Menu and view the particular transducer reading (the evaporator pressure, condenser pressure, economizer pressure, pump inlet pressure, pump outlet pressure, bearing inlet pressure, bearing outlet pressure).
4. To calibrate a device, view the particular reading on the screen. It should read 0 kPa. If the reading is not 0 kPa, but within 35 kPa, the value may be set to zero while the appropriate transducer parameter is highlighted. The value will now go to zero. No high end calibration is necessary for REF PUMP DELTA P or flow devices. If the transducer value is not within the calibration range, the transducer will return to the original reading. If the pressure is within the allowed range (noted above), check the voltage ratio of the transducer. To obtain the voltage ratio, divide the voltage (dc) input from the transducer by the supply

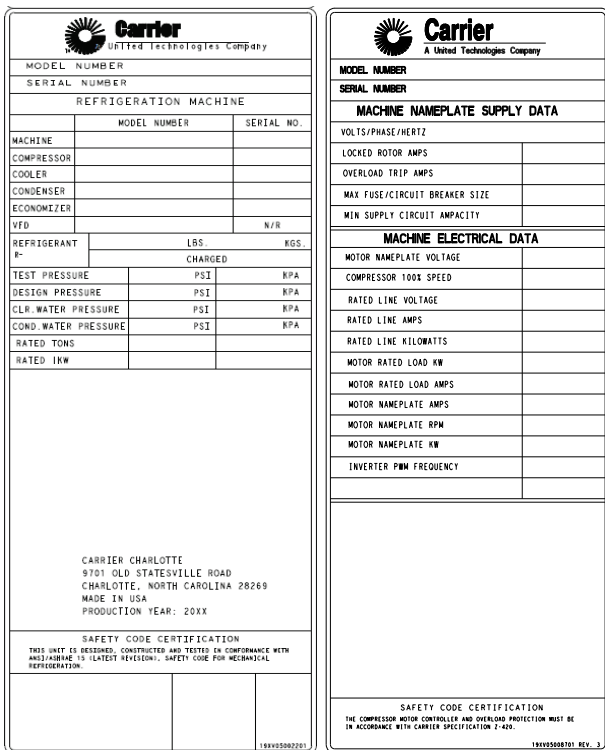

Fig. 32 — Machine Identification Nameplate and VFD Electrical Nameplate

voltage signal (see Maintenance Others in Maintenance Menu) or measure across the positive (+ red) and negative (– black) leads of the transducer. The voltage ratio must be between 0.80 and 0.11 for the software to allow calibration. Rotate the waterside flow pressure device from the inlet nozzle to the outlet nozzle and repeat this step. If rotating the waterside flow device does not allow calibration then pressurize the transducer until the ratio is within range. Then attempt calibration again.

5. A high pressure point can be calibrated between 10 and 30 psig (68.9 and 206.8 kPa) by attaching a regulated pressure source (usually from a nitrogen cylinder with high resolution pressure gage). The high pressure point can be calibrated by accessing the appropriate transducer parameter on the PRESSURES screen, highlighting the parameter, then increasing or decreasing the value to the exact pressure on the refrigerant gage.

Pressures at high altitude locations must be compensated for, so the chiller temperature/pressure relationship is correct. This is set in the Service Parameters (Configuration Menu).

The PIC6 does not allow calibration if the transducer is too far out of calibration. In this case, a new transducer must be installed and re-calibrated.

IMPORTANT: When screen display calibration is complete, do not press Calibration Enable/Dsable since the new values will be deleted. Values are kept by exiting the pressure sensor table.

OPTIONAL THERMAL DISPERSION FLOW SWITCH CALIBRATION

Set the flow through the water circuit to the minimum safe flow that will be encountered.

Reduce the sensitivity of the switch by turning the adjustment counter-clockwise until the yellow LED turns off. This indicates that the switch is now open.

Increase the sensitivity of the flow switch by turning the adjustment potentiometer clockwise until the yellow LED is lit.

In case of nuisance trips at low flow, increase the sensitivity of the switch by turning the potentiometer clockwise.

HYDRAULIC STATUS

The HYDRAULIC STATUS screen (access from the Main Menu) provides a convenient way to detect if any of the evaporator/condenser pressure switches (if installed) are in need of calibration. See Fig. 33 for the hydraulic status menu. With no flow the water delta should read 0 kPa. If it does not, the value may be set to zero using PRESSURE SENSOR CALIB located in the Maintenance Menu. See Fig. 34 for the pressure sensor calibration menu. High end calibration is not necessary.

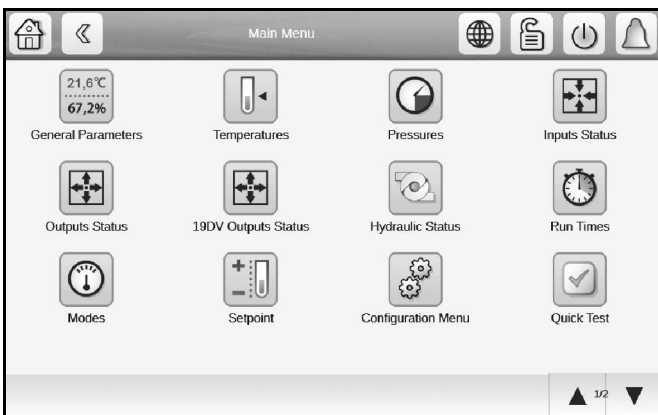

Fig. 33 — Hydraulic Status Menu

IMPORTANT: When screen display calibration is complete, do not press Calibration Enable/Dsable since the new values will be deleted. Values are kept by exiting the pressure sensor table.

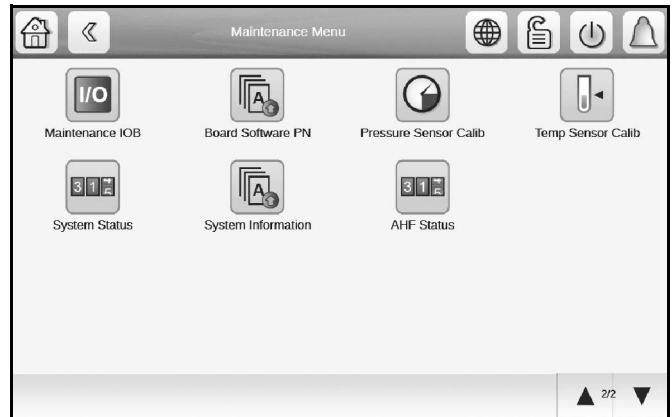

Fig. 34 — Pressure Sensor Calibration Menu

INITIAL START-UP

Preparation

Before starting the chiller, verify:

1. Power is on to the VFD, chiller control panel, water pumps, and other equipment as required.
2. Cooling tower water is at proper level and at-or-below design entering temperature.
3. Chiller is charged with refrigerant and all refrigerant valves are in their proper operating positions.
4. Valves in the evaporator and condenser water circuits are open and flow is as per design.

NOTE: If the pumps are not automatic, ensure water is circulating properly.

CAUTION

Do not permit water or brine that is warmer than 150°F (65°C) to flow through the evaporator or condenser. Refrigerant overpressure may discharge through the relief device and result in the loss of refrigerant charge (applicable only with standard Charlotte rupture disk).

5. Access the PUMPDOWN/LOCKOUT feature from the Maintenance Menu. Press the End Lockout button on the touch screen and accept the “press OK to Terminate Lockout?” prompt. The unit is reset to operating mode. The chiller is locked out at the factory to prevent accidental start-up.

Check Motor Rotation

1. Close the starter enclosure door.
2. Apply 3-phase power to drive.
3. The VFD checks for proper phase rotation as soon as power is applied to the starter and the PIC6 controls power up.
4. An alarm message will appear on the HMI screen if the phase rotation is incorrect. If this occurs reverse any 2 of the 3 incoming power leads to the starter and reapply power. The motor is now ready for a rotation check.
5. Go to Main Menu, Quick Test and Enable Quick Test following by enabling Motor Rotation Check. This starts the following sequence:
 - a. Fully open the first IGV (inlet guide vane).

- b. For lube assembly, open evaporator control valve, close condenser control valve, and close evaporator control valve. Run refrigerant pump for 30 seconds.
 - c. Start the motor and ramp to 5 Hz in 10 seconds.
 - d. Once the motor speed reaches 5 Hz, stop motor.
 - e. Stop refrigerant pump 1 minute after motor speed reaches 5 Hz, then reset all 4 refrigerant lubrication valves to close.
 - f. Three minutes after motor speed reaches 5 Hz, close first IGV. Status can be followed in Quick Test as Check State IDLE=0, PreLub=1, Rotat=2, PosLub=3, End=4.
6. When the VFD is energized and the motor begins to turn, check for clockwise motor rotation through first stage sight glasses. See Fig. 35.

IMPORTANT: Do not check motor rotation during coast-down. Rotation may have reversed during equalization of vessel pressures.



CORRECT MOTOR ROTATION IS CLOCKWISE WHEN VIEWED THROUGH SUCTION PIPE LEADING TO COMPRESSOR 1ST STAGE SIGHT GLASS

TO CHECK ROTATION, ENERGIZE COMPRESSOR MOTOR MOMENTARILY. DO NOT LET MACHINE DEVELOP CONDENSER PRESSURE. CHECK ROTATION IMMEDIATELY.

ALLOWING CONDENSER PRESSURE TO BUILD OR CHECKING ROTATION WHILE MACHINE COASTS DOWN MAY GIVE A FALSE INDICATION DUE TO GAS PRESSURE EQUALIZING THROUGH COMPRESSOR.

Fig. 35 — Correct Motor Rotation

Check Refrigerant Lube Assembly

1. In Quick Test the refrigerant lube pressure can be checked. Open evaporator control valve, then run the refrigerant pump. Pressure drop across the refrigerant pump must exceed 8 psig (55 kPa). If pressure drop is negative, check the pump rotation. If pressure drop is below 8 psig (55 kPa), check for clogged filter drier or bearing supply filter.
2. Press the Stop button and listen for any unusual sounds from the compressor as it coasts to a stop.

To Prevent Accidental Start-Up

A chiller STOP override setting may be entered to prevent accidental start-up during service or whenever necessary. From the Main Menu, access the General Parameters Menu and use the down arrow to reach Stop Override on the GENUNIT table. Change Stop Override to Yes; then execute the command by touching the lightning button. The message “ALM-276 Protective Limit - Stop Override” will appear in the Home Screen message area. To restart the chiller, access the same screen and change the Stop Override option to No.

Check Chiller Operating Condition

Check to be sure that chiller temperatures, pressures, water flows, and refrigerant levels indicate the system is functioning properly.

Instruct the Customer Operator(s)

Ensure the operator understands all operating and maintenance procedures. Point out the various chiller parts and explain their function as part of the complete system.

EVAPORATOR-CONDENSER

High side float chamber, relief devices, refrigerant charging valve, temperature sensor locations, pressure transducer locations, Schrader fittings, waterboxes and tubes, and vents and drains.

MOTOR COMPRESSOR ASSEMBLY

Guide vane actuator, transmission, motor cooling system, temperature and pressure sensors, sight glasses, motor temperature sensors, and compressor serviceability.

COMPRESSOR LUBRICATION SYSTEM

Valves, dryers and filters, liquid level switch and inhibitor reclaim system.

ECONOMIZER

Float valve, drain valve, Schrader fitting, damper valve.

CONTROL SYSTEM

CCN and LOCAL start, reset, menu, softkey functions, HMI operation, occupancy schedule, set points, safety controls, and auxiliary and optional controls.

PURGE

Check for potential leaks by monitoring purge hours in RUN-TIME. Note changes over time.

AUXILIARY EQUIPMENT

Starters and disconnects, separate electrical sources, pumps, and cooling tower.

DESCRIBE CHILLER CYCLES

Refrigerant, motor cooling, lubrication, and liquid reclaim.

REVIEW MAINTENANCE

Scheduled, routine, and extended shutdowns, importance of a log sheet, importance of water treatment and tube cleaning, and importance of maintaining a leak-free chiller.

SAFETY DEVICES AND PROCEDURES

Electrical disconnects, relief device inspection, and handling refrigerant.

CHECK OPERATOR KNOWLEDGE

Start, stop, and shutdown procedures, safety and operating controls, refrigerant charging, and job safety.

REVIEW THE START-UP, OPERATION, AND MAINTENANCE MANUAL.

FINE TUNING VPF (VARIABLE PRIMARY FLOW) SURGE PREVENTION

Figures 36-39 show how the parameters defined below will affect the configured surge line. The menu can be found under **Main Menu → Configuration Menu → Surge Correction Config.**

NOTE: Before tuning surge prevention, check for VFD (variable frequency drive) speed limitation or capacity overrides. If the source of low capacity is found in one of these places, do not proceed with an attempt to tune the Surge Prevention configurations.

If capacity is not reached
and

1. ACTUAL GUIDE VANE POSITION < GUIDE VANE TRAVEL RANGE

and

2. SURGE PREVENTION ACTIVE = YES (can be identified in *Main Menu* → *Maintenance Menu* → *Surge Correction*)

and

3. PERCENT LINE CURRENT < 100%

then the surge line is probably too conservative.

Note the following parameters from HMI when maximum ACTUAL LINE CURRENT is achieved:

- EVAPORATOR REFRIGERANT TEMP
- EVAPORATOR PRESSURE
- CONDENSER REFRIG TEMP
- CONDENSER PRESSURE
- ACTUAL GUIDE VANE POSITION
- ACTUAL LINE CURRENT

The ACTIVE DELTA TSAT and the CALC REF DELTA TSAT can be monitored on the *Maintenance Menu* → *Surge Correction* screen. When ACTUAL DELTA TSAT exceeds CALC REF DELTA TSAT + ENVELOPE LINE OFFSET surge prevention will occur.

If ACTUAL GUIDE VANE POSITION is less than 30%, then increase SURGE DELTA TSMIN in steps of 2°F (1.2°C) until one of the three conditions listed above no longer applies. Do not change SURGE DELTA TSMAX.

If ACTUAL GUIDE VANE POSITION is greater than 60%, then increase SURGE DELTA TSMAX in steps of 2°F (1.2°C) until cooling capacity is reached or one of conditions listed above no longer applies. Do not change SURGE/HGBP DELTA TSMIN.

If ACTUAL GUIDE VANE POSITION is more than 30% AND less than 60%, then:

1. Increase SURGE DELTA TSMIN in steps of 2°F (1.2°C).
2. Increase SURGE DELTA TSMAX in steps of 2°F (1.2°C).
3. Repeat Steps 1 and 2 until one of the conditions listed above no longer applies.

NOTE: DELTA TSMIN should seldom need to be increased more than 10 degrees above the selection program value. Likewise, DELTA TSMAX rarely requires more than a 2°F (1.2°C) increase.

If surge is encountered then the controls surge prevention algorithm surge line is probably too optimistic or high. Note following parameters from HMI at surge:

- EVAPORATOR REFRIGERANT TEMP
- EVAPORATOR PRESSURE
- CONDENSER REFRIG TEMP
- CONDENSER PRESSURE
- ACTUAL GUIDE VANE POSITION
- AVERAGE LINE CURRENT

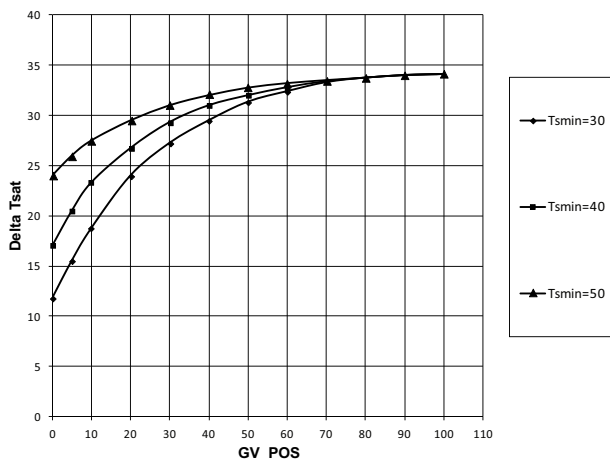

Fig. 36 — Effect of SURGE DELTA TSMIN on Surge Prevention

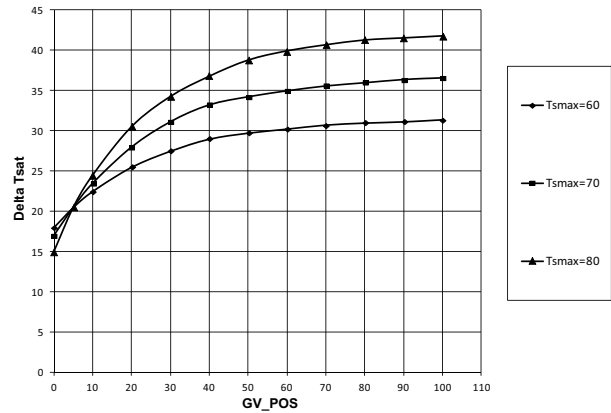

Fig. 37 — Effect of SURGE DELTA TSMAX on Surge Prevention

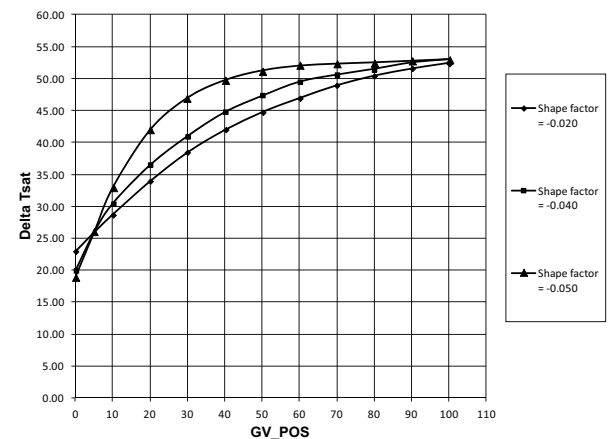

Fig. 38 — Effect of SURGE LINE SHAPE FACTOR on Surge Prevention

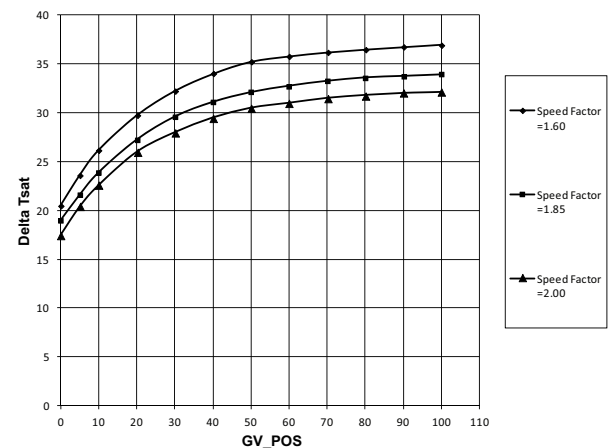

Fig. 39 — Effect of SURGE LINE SPEED FACTOR on Surge Prevention

If ACTUAL GUIDE VANE POSITION is less than 30%, go to Step 1. If ACTUAL GUIDE VANE POSITION is greater than 60%, then go to Step 3.

1. Do not change SURGE LINE SHAPE FACTOR from the value selected by Chiller Builder (ECAT). Decrease SURGE DELTA TSMIN in 1°F steps up to 5 times. Monitor chiller for surge.

2. If ACTUAL GUIDE VANE POSITION is still less than 30% and Step 1 failed, increase the value of SURGE LINE SHAPE FACTOR in steps of 0.01 up to 2 times. For example, if surge is encountered when shape factor is -0.06 , increase the SURGE LINE SHAPE FACTOR to -0.05 . If this does not solve the problem, go to Step 5, even if ACTUAL GUIDE VANE POSITION is less than 30%.
3. Do not change SURGE LINE SHAPE FACTOR from the value selected by Chiller Builder (ECAT). Decrease SURGE DELTA TSMAX by 1°F steps up to 5 times. Monitor chiller for surge.
4. If ACTUAL GUIDE VANE POSITION is greater than 60% and Step 3 failed to eliminate surge, then set SURGE DELTA TSMAX to 5°F below the value specified by Chiller Builder (ECAT). Increase the value of the SURGE LINE SHAPE FACTOR in steps of 0.01 up to 2 times. For example, if surge is encountered when the SURGE LINE SHAPE FACTOR is -0.06 , increase the SURGE LINE SHAPE FACTOR to -0.05 . If this does not solve the problem, go to Step 5, even if ACTUAL GUIDE VANE POSITION is greater than 60%.
5. If ACTUAL GUIDE VANE POSITION is greater than 30% but less than 60% or if Step 2 failed (with ACTUAL GUIDE VANE POSITION less than 30) or if Step 4 failed (with ACTUAL GUIDE VANE POSITION greater than 60), then perform this step. Do not change SURGE LINE SHAPE FACTOR from the value specified by Chiller Builder (ECAT). Reset SURGE DELTA TSMIN and SURGE DELTA TSMAX to the value specified by Chiller Builder (ECAT). Decrease SURGE DELTA TSMIN and SURGE DELTA TSMAX in steps of 1°F up to 5 times. Monitor chiller for surge.

If the drive does not slow down adequately at part load, then the machine may be operating at a point above the configured “software” surge line and the machine is in surge prevention mode. Check for a surge protection message on the HMI. If the unit is not in a surge protection state, then the ENVELOPE SPEED FACTOR may need to be increased (more aggressive surge line protection) in combination with a decrease in the SURGE LINE SHAPE FACTOR.

OPERATING INSTRUCTIONS

Operator Duties

1. Become familiar with the chiller and related equipment before operating the chiller.
2. Prepare the system for start-up, start and stop the chiller, and place the system in a shutdown condition.
3. Maintain a log of operating conditions and document any abnormal readings.
4. Inspect the equipment, make routine adjustments, and perform a Control Test. Maintain the proper refrigerant levels.
5. Protect the system from damage during shutdown periods.
6. Maintain the set point, time schedules, and other PIC functions.

Prepare the Chiller for Start-Up

Follow the steps described in the Initial Start-Up section, page 36.

To Start the Chiller

1. Start the water pumps, if they are not automatic.
2. Press the Start/Stop icon on the HMI home screen to start the system. If the chiller is in the OCCUPIED mode and the start timers have expired, the start sequence will start. Follow the procedure described in the Start-Up/Shutdown/Recycle Sequence section, page 16.

Check the Running System

After the compressor starts, the operator should monitor the display and observe the parameters for normal operating conditions:

1. The normal bearing temperature should be about 95°F (35°C). Alert will initiate at 104°F (40°C) and Alarm will be initiated at 122°F (50°C).
2. The First Stage and Second Stage Bearing Temperatures can be accessed from the Temperatures menu. If the bearing temperature is high or in Alarm/Alert state with the refrigerant pump running, stop the chiller and determine the cause of the high temperature. *Do not restart* the chiller until corrected.
3. The liquid level sensor on the condenser float chamber should indicate Closed in the INPUT menu.
4. During startup a Low Refrigerant Pressure Difference alarm will be generated if the refrigerant pump supply pressure as viewed in the “Startup Sequence” or “Pressure” screen is less than 8 psid (55.2 kPa). There will also be an alarm if compressor is ON (startup completed) and the bearing pressure drop is less than 10 psid for 10 seconds.
5. The moisture indicator sight glass on the refrigerant motor cooling line should indicate single phase refrigerant flow and a dry condition; i.e., solid liquid with no turbulent bubbles.
6. The condenser pressure and temperature varies with the chiller design conditions. Typically the pressure will range from -1.5 to 17.5 psig (-10.3 to 120.6 kPa). with a corresponding temperature range of 60 to 105°F (15 to 41°C). The condenser entering water temperature should be controlled below the specified design entering water temperature to save on compressor kilowatt requirements.
7. Evaporator pressure and temperature also will vary with the design conditions. Typical pressure range will be between -7.7 to -5.0 psig (-50.8 kPa to -35 kPa), with temperature ranging between 34 and 45°F (1.1 and 7.2°C).
8. The active electrical demand setting can be overridden to limit the compressor kW, or the pulldown rate can be decreased to avoid a high demand charge. It may be necessary to demand limit chiller. Base Demand Limit% is set at the Setpoint Menu in the Main Menu. Demand limit is

based on chiller amps and kW is based on configured Demand Limit Source in *Main Menu*→*Configuration Menu*→*General*. Pulldown rate can be based on load rate or temperature rate and is viewed at *Main Menu*→*Configuration Menu*→*General*. Configuration of the actual ramping rate is done in the Service Parameters Menu (*Main Menu*→*Configuration Menu*→*Service Parameters*) where either Amps/KW Ramp per minute or Temperature Ramp per minute can be adjusted to slow down the chiller response.

9. High and low float chambers each provide two sight glasses for looking into the float chamber to confirm proper float operation. Note that the sight glasses on the float covers are used to diagnose a float operation failure of fully closed, stuck in one position, or fully open. The sight glasses are not used to identify correct refrigerant charge.

To Stop the Chiller

The occupancy schedule starts and stops the chiller automatically once the time schedule is configured.

The unit can be stopped manually using the HMI by pressing the green Start/Stop icon . The Unit Start/Stop screen is displayed. Press Confirm Stop. The compressor will then follow the normal shutdown sequence as described in the Start-Up/Shutdown/Recycle Sequence section on page 16. The chiller is now in the OFF control mode.

IMPORTANT: Do not attempt to stop the chiller by opening an isolating knife switch. High intensity arcing may occur.

If the chiller is stopped by an alarm condition, *do not restart the chiller* until the problem is diagnosed and corrected.

After Limited Shutdown

No special preparations should be necessary. Follow the regular preliminary checks and starting procedures.

PREPARATION FOR EXTENDED SHUTDOWN

If freezing temperatures are likely to occur in the chiller area, drain the chilled water, condenser water, and pumpout condenser water circuits to avoid freeze-up. Keep the waterbox drains open. Ensure that chiller is powered up so purge can automatically remove non-condensables from the low pressure chiller system during the shutdown. It is recommended not to store the refrigerant in the unit if below-freezing temperatures are anticipated or if the extended shutdown extends past a normal seasonal shutdown. In that case both refrigerant and water side should be purged with positive pressure of dry nitrogen.

After Extended Shutdown

Ensure water system drains are closed. It may be advisable to flush water circuits to remove any soft rust that may have formed. This is a good time to brush the tubes and inspect the Schrader fittings on the waterside flow devices for fouling, if necessary.

Match the actual to the recorded nitrogen pressure prior to the extended shutdown to determine if a leak is present. Check the evaporator pressure on the HMI panel and compare it to the original holding charge that was left in the chiller. If, after adjusting for ambient pressure changes, any change in pressure is indicated, check for refrigerant leaks. See Check Chiller Tightness section, page 19.

If charge was removed, recharge the chiller by transferring refrigerant from the pumpout storage tank (if supplied). Follow the Pumpout and Refrigerant Transfer Procedures section on page 43. Observe freeze-up precautions.

Carefully make all regular preliminary and running system checks.

Cold Weather Operation

When the entering condenser water temperature drops very low, the operator should automatically cycle the cooling tower fans off to keep the temperature up and tower bypass piping or condenser water flow modulation may be required. Economizer Liquid bypass option may be required for units operating at low lift outside of the selected lift as identified in the Carrier Equipment Selection Program.

IMPORTANT: A field-supplied water temperature control system for condenser water should be installed. The system should be able to maintain the leaving condenser water temperature at design conditions.

Manual Guide Vane Operation

It is possible to manually operate the guide vanes in order to check control operation or to control the guide vanes in an emergency. Manual operation is possible by overriding the target guide vane position. Forcing the guide vanes is only possible in the Lab Test Forced factory menu.

NOTE: Manual control overrides the configured pulldown rate during start-up and permits the guide vanes to open at a faster rate. Motor current above the electrical demand setting, capacity overrides, and chilled water temperature below the control point override the manual target and close the guide vanes. For descriptions of capacity overrides and set points, see the 19DV with PIC6 Controls Operation and Troubleshooting guide.

Refrigeration and Service Log

A refrigeration log (as shown in Fig. 40), is a convenient checklist for routine inspection and maintenance and provides a continuous record of chiller performance. It is also an aid when scheduling routine maintenance and diagnosing chiller problems.

Keep a record of the chiller pressures, temperatures, and liquid levels on a sheet similar to the one in Fig. 40. Automatic recording of data is possible by using CCN devices such as the Data Collection module and a Building Supervisor. Contact a Carrier representative for more information.

REFRIGERATION LOG CARRIER 19DV SEMI-HERMETIC CENTRIFUGAL REFRIGERATION MACHINE

PLANT _____ MACHINE MODEL NO. _____ MACHINE SERIAL NO. _____

DESCRIPTION			DATE				
EVAPORATOR	REFRIGERANT	PRESSURE SAT					
		LIQUID TEMP					
		LEVEL					
	WATER	FLOW					
		TEMP IN					
		TEMP OUT					
CONDENSER	REFRIGERANT	PRESSURE					
		TEMP SAT					
	WATER	FLOW					
		TEMP IN					
		TEMP OUT					
COMPRESSOR	CAPACITY	GV1 ACTUAL POS					
		GV2 ACTUAL POS					
	BEARINGS	1ST STAGE TEMP					
		2ND STAGE TEMP					
	REFRIGERANT LUBE	BEARING DELTA P					
		REF PUMP DELTA P					
DRIVE TRAIN	MOTOR	RUNNING AMPS					
		TEMPERATURE					
	VFD	ACTUAL SPEED					
PURGE	RUNTIME	AV DAILY PURGE IN 7 DAYS					

REMARKS: Indicate shutdowns on safety controls, repairs made, and inhibitor or refrigerant added or removed. Include amounts.

Fig. 40 — Refrigeration and Service Log

PUMPOUT AND REFRIGERANT TRANSFER PROCEDURES

Preparation

For refrigerant side service work the refrigerant can be isolated in a storage tank. Note that R-1233zd(E) is a low pressure refrigerant, so therefore it is recommended to use refrigerant equipment suited for low pressure refrigerants. The following procedures and Fig. 41 and 42 describe how to transfer refrigerant from vessel to vessel and perform chiller evacuation.

⚠ WARNING

During transfer of refrigerant into and out of the optional storage tank, carefully monitor the storage tank level gage. Do not fill the tank more than 90% of capacity to allow for refrigerant expansion. Overfilling may result in damage to the tank or the release of refrigerant which will result in personal injury or death.

⚠ CAUTION

If equipped, the power to the pumpout compressor oil heater must be on whenever any valve connecting the pumpout compressor to the chiller or storage tank is open. Leaving the heater off will result in oil dilution by refrigerant and can lead to compressor failure. Similarly a recovery unit suited for low pressure refrigerant should be used.

⚠ CAUTION

Always run the chiller evaporator and condenser water pumps and always charge or transfer refrigerant as a gas when the chiller pressure is less than -15 in. Hg (-51 kPa). Below this pressure, liquid refrigerant flashes into gas, resulting in extremely low temperatures in the evaporator/condenser tubes and possibly causing tube freeze-up.

⚠ CAUTION

Do not mix 19DV R-1233zd(E) refrigerant with charge from chillers that use compressor oils and ensure that tanks previously used with a different refrigerant have been cleaned in order to avoid refrigerant contamination. Compressor and heat exchanger damage can result.

⚠ CAUTION

Transfer, addition, or removal of refrigerant in spring-isolated chillers may place severe stress on external piping if springs have not been blocked in both up and down directions.

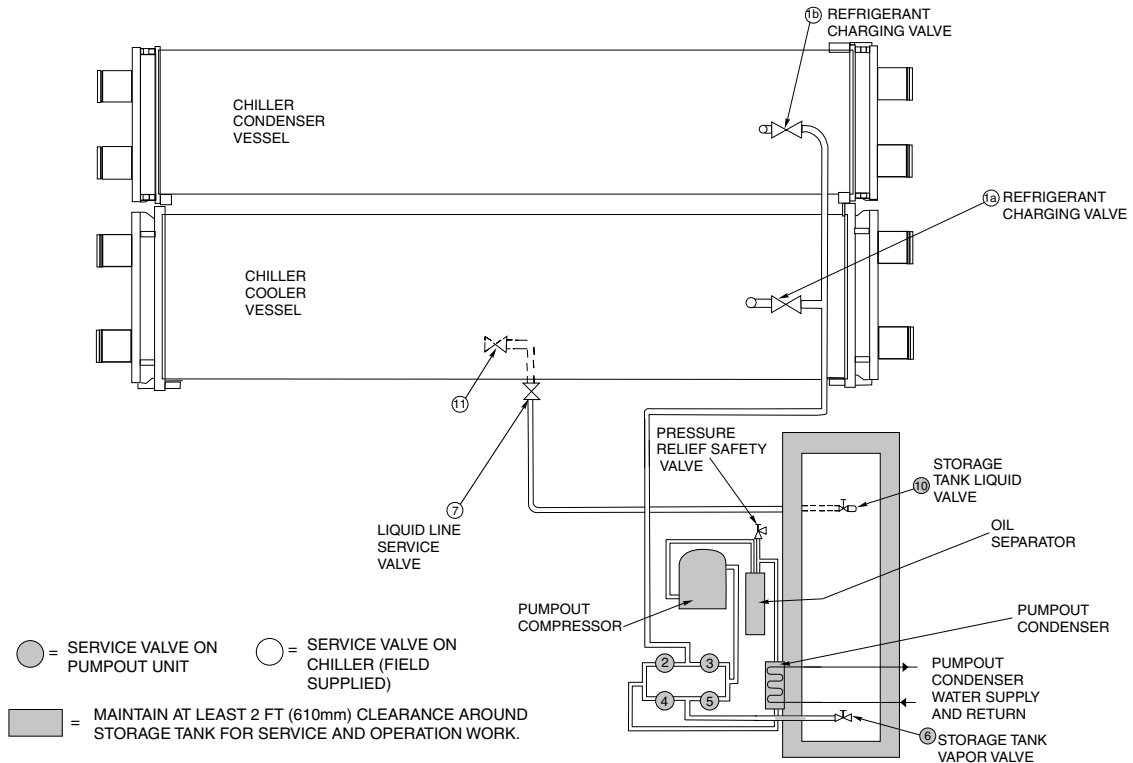

Fig. 41 — Typical Optional Pumpout System Piping Schematic with Storage Tank

PUMP-OUT WITH STORAGE TANK

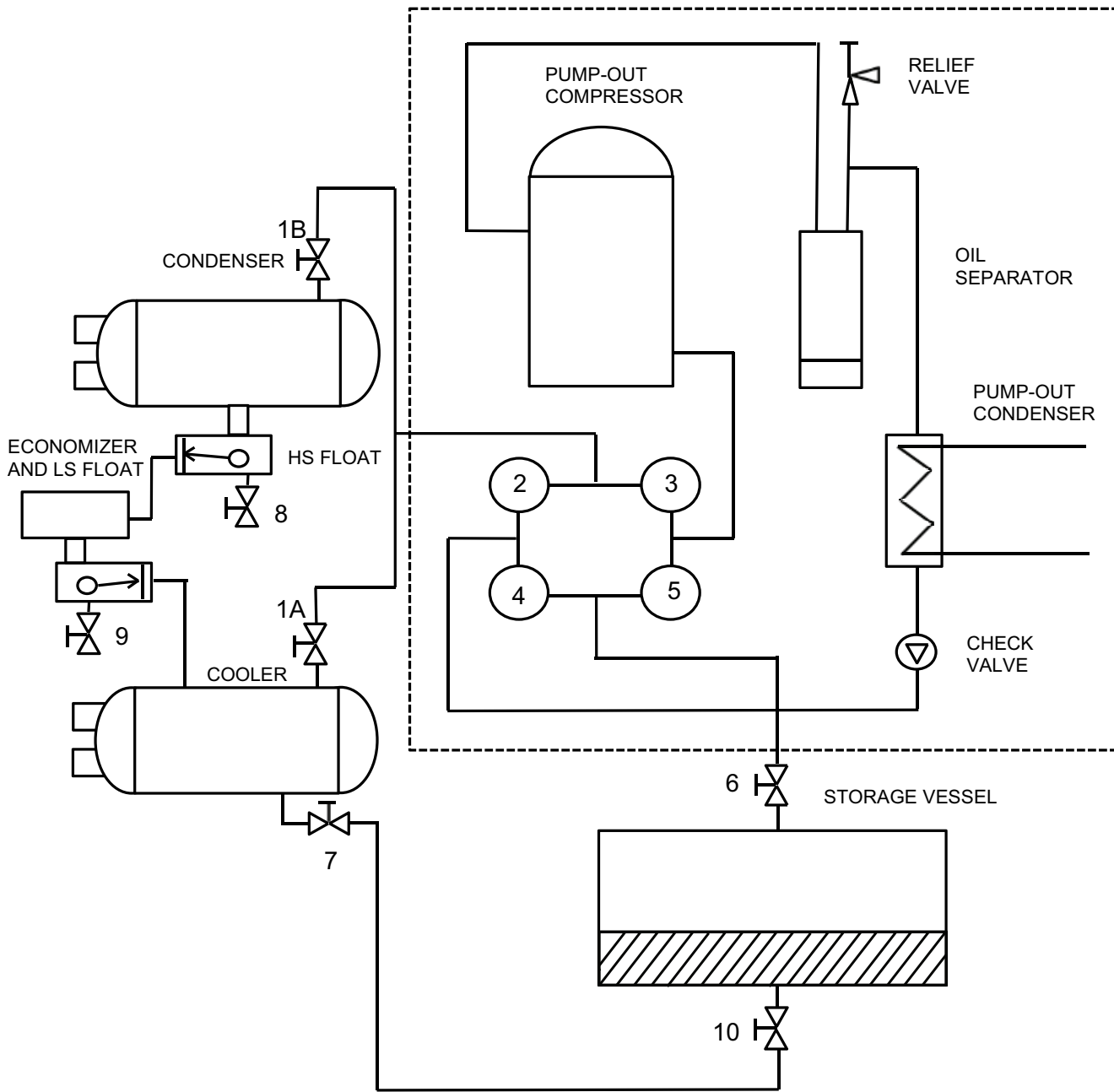

Fig. 42 — Refrigerant Transfer Schematic

The following procedures assume that system is piped in agreement with Fig. 42. Use the PIC6 Pumpdown/Lockout feature under the Maintenance menu.

NOTE: Instructions assume pumpout unit with four control valves oriented as shown. Actual equipment may have a different design, in which case the procedure changes.

Transfer Refrigerant from Storage Tank Vessel to Chiller

1. Equalize refrigerant pressure.
 - a. Turn on chiller water pumps, establishing water flow (assumes vacuum condition in chiller system).
 - b. Open (O) and close (C) pumpout and storage tank valves according to below table.

VALVE	1A	1B	2	3	4	5	6	7	8	9	10
CONDITION	O	O	C	O	C	C	O	C	C	C	C

- c. Gradually open valve 5 to allow vapor pressure to equalize between storage tank and chiller system.

- d. Open valve 5 fully after the chiller pressure exceeds -12.7 in. Hg (58.3 kPa abs) corresponding to a saturation temperature of 40°F (4.4°C). The chiller water pumps can be turned off (if desired). When vacuum pressure is fully equalized, close valve 5.

VALVE	1A	1B	2	3	4	5	6	7	8	9	10
CONDITION	O	O	C	O	C	C	O	C	C	C	C

- e. Open valve 7 and 10 to prepare to let higher pressure in the recovery tank push liquid refrigerant into the chiller through the evaporator charging/vacuum valve.

VALVE	1A	1B	2	3	4	5	6	7	8	9	10
CONDITION	O	O	C	O	C	C	O	O	C	C	O

2. Push liquid to chiller; then remove remaining vapor from storage tank.

- a. Open valve 4.
- b. Ensure pumpout condenser water is off; then turn on the pumpout compressor in manual mode to push liquid to chiller. Monitor the storage tank level until tank is empty of liquid refrigerant.
- c. Close charging valves 7 and 10.
- d. Turn off the pumpout compressor.

VALVE	1A	1B	2	3	4	5	6	7	8	9	10
CONDITION	O	O	C	O	O	C	O	C	C	C	C

- e. To prepare for removal of remaining refrigerant vapor in storage tank, close pumpout valves 3 and 4 and open valves 2 and 5.

VALVE	1A	1B	2	3	4	5	6	7	8	9	10
CONDITION	O	O	O	C	C	O	O	C	C	C	C

- f. Turn on the pumpout condenser water.
- g. Run pumpout unit in auto until the vacuum switch is satisfied. This occurs approximately at 15 in. Hg vacuum (48 kPa absolute or 7 psia), removing the residual refrigerant vapor from the recovery tank and condensing the a liquid in the chiller. Close valves 1a, 1b, 2, 5, 6.

VALVE	1A	1B	2	3	4	5	6	7	8	9	10
CONDITION	C	C	C	C	C	C	C	C	C	C	C

- h. Turn off pumpout condenser water.

Transfer Refrigerant from Chiller to Storage Tank Vessel

1. Equalize refrigerant pressure. Be sure to run pumps if saturated refrigerant temperature is near the freezing point to avoid potential tube freeze up.
 - a. Dehydrate the refrigerant storage vessel and connected hoses/piping so there are no non-condensables mixed with the refrigerant.
 - b. Open (O) and close (C) pumpout and storage tank valves according to below table.

VALVE	1A	1B	2	3	4	5	6	7	8	9	10
CONDITION	O	O	C	O	C	C	O	C	C	C	C

- c. Gradually open valve 5 to allow vapor pressure to equalize between chiller system and storage tank, and open valve 7 and 10 to allow liquid refrigerant to drain by gravity.

VALVE	1A	1B	2	3	4	5	6	7	8	9	10
CONDITION	O	O	C	O	C	O	O	O	C	C	O

2. Push remaining liquid, followed by refrigerant vapor removal from chiller. Open valve 7 and 10 to prepare to let higher pressure in the recovery tank push liquid refrigerant into the chiller through the evaporator charging/vacuum valve.
 - a. To prepare for liquid push, turn off the pumpout condenser water. Place valves in the following positions.

VALVE	1A	1B	2	3	4	5	6	7	8	9	10
CONDITION	O	O	O	C	C	O	O	O	C	C	O

- b. Run the pumpout compressor in manual until all liquid is pushed out of the chiller (approximately 45 minutes). To drain remaining liquid in HS and LS float chambers refrigerant hoses can be connected to valve 8 and 9 and this liquid can be drained (or pushed) to the storage tank prior to next step. Close valves 2, 5, 7 and 10, then stop compressor.

VALVE	1A	1B	2	3	4	5	6	7	8	9	10
CONDITION	O	O	C	C	C	C	O	C	C	C	C

- c. Turn on pumpout condenser water.
- d. Open valves 3 and 4, and place valves in the following positions.

VALVE	1A	1B	2	3	4	5	6	7	8	9	10
CONDITION	O	O	C	O	O	C	O	C	C	C	C

- e. Run the pumpout compressor until the chiller pressure reaches -7.5 psig (49.5 kPa abs), followed by turning off the pumpout compressor. Note it is possible that the pressure switch is satisfied before this condition. Warm chiller condenser water will boil off any entrapped liquid refrigerant, and chiller pressure will rise.
- f. When chiller pressure increases to -5.5 psig (63 kPa abs) turn on the pumpout compressor until the pressure reaches 7.5 psig (49.5 kPa abs) again; then turn off the pumpout compressor. Repeat this process until the chiller pressure no longer rises.
- g. Start the chiller water pumps (condenser and evaporator), establish water flow. At this point turn on the pumpout compressor in auto until the vacuum switch is satisfied. This occurs at approximately 15 in. Hg vacuum (48 kPa abs, 7 psia).
- h. Close all valves.

VALVE	1A	1B	2	3	4	5	6	7	8	9	10
CONDITION	C	C	C	C	C	C	C	C	C	C	C

- i. Turn off the pumpout condenser water.

DISTILLING THE REFRIGERANT

1. Transfer the refrigerant from the chiller to the pumpout storage tank as described in the Transfer Refrigerant from Chiller to Storage Tank Vessel section.
2. Equalize the refrigerant pressure
 - a. Turn on chiller water pumps and monitor chiller pressures.
 - b. Close pumpout and storage tank valves 2, 4, 5, 7 and 10. Open any isolation valves, if present. Open pumpout and storage tank valves 3 and 6; open chiller valves 1a and 1b.

VALVE	1A	1B	2	3	4	5	6	7	8	9	10
CONDITION	O	O	C	O	C	C	O	C	C	C	C

- c. Gradually crack open valve 5 to increase chiller pressure to -7.5 psig (49.5 kPa abs). Slowly feed refrigerant to prevent freeze-up.
- d. Open valve 5 fully after the chiller pressure rises above the freezing point. Let the storage tank and chiller pressure equalize.
3. Transfer remaining refrigerant.
 - e. Set valves as per below table and turn on the pumpout condenser water.

VALVE	1A	1B	2	3	4	5	6	7	8	9	10
CONDITION	O	O	O	C	C	O	O	C	C	C	C

- f. Run the pumpout compressor until all refrigerant is removed from the storage tank (remaining content in tank is non-condensables).
- g. Turn off the pumpout compressor, close all valves, and turn off the pumpout condenser water.

VALVE	1A	1B	2	3	4	5	6	7	8	9	10
CONDITION	C	C	C	C	C	C	C	C	C	C	C

4. Drain the contaminants from the bottom of the storage tank into a container and dispose of it safely.

GENERAL MAINTENANCE

Refrigerant Properties

The standard refrigerant for the 19DV chiller is HFO R-1233zd(E). At normal atmospheric pressure, HFO R-1233zd(E) will boil at 65°F (18°C) and must, therefore, be kept in pressurized containers or storage tanks. The refrigerant is practically odorless when mixed with air and is noncombustible at atmospheric pressure. Read the Material Safety Data Sheet and the latest ASHRAE Safety Guide for Mechanical Refrigeration to learn more about safe handling of this refrigerant.

⚠ DANGER

HFO R-1233zd(E) in heavy concentrations may displace enough oxygen to cause asphyxiation. When handling this refrigerant, protect the hands and eyes and avoid breathing fumes.

Adding Refrigerant

Follow the procedures described in the Trim Refrigerant Charge section, page 48.

⚠ CAUTION

Always use the compressor pumpdown function in the PUMPDOWN/LOCKOUT feature to turn on the evaporator pump and lock out the compressor when transferring refrigerant. Liquid refrigerant may flash into a gas and cause possible freeze-up and damage to the unit when the chiller pressure is below -15 in. Hg (-53 kPa) for HFO R-1233zd(E).

Adjusting the Refrigerant Charge

If the addition or removal of refrigerant is required to improve chiller performance, follow the procedures given under the Trim Refrigerant Charge section, page 48.

Refrigerant Leak Testing

Since parts of the refrigerant system operate in vacuum, non-condensables will enter the cooling systems. The PIC6 HMI will issue an alert indicating excessive purge operation. Leaks, which cause frequent purge cycles, should be repaired without delay. Non-condensable gas in the machine causes higher than normal condenser pressure, compressor surge at start-up, and frequent purge cycles, so locate and repair any leaks as soon as possible. Before making any necessary repairs to a leak, transfer all refrigerant from the vessel.

Leak Rate

It is recommended by ASHRAE that chillers be taken off line immediately and repaired if the refrigerant leak rate for the entire chiller is more than 10% of the operating refrigerant charge per year.

Carrier recommends that leaks totaling less than the above rate but more than a rate of 0.1% of the total charge per year should be repaired during annual maintenance or whenever the refrigerant is transferred for other service work.

Test After Service, Repair, or Major Leak

If all the refrigerant has been lost or if the chiller has been opened for service, the chiller or the affected vessels must be pressure tested and leak tested. Refer to the Leak Test Chiller section on page 22 to perform a leak test.

⚠ WARNING

HFO R-1233zd(E) should not be mixed with air or oxygen and pressurized for leak testing. In general, this refrigerant should not be present with high concentrations of air or oxygen above atmospheric pressures, because the mixture can undergo combustion.

TESTING WITH REFRIGERANT TRACER

Use an environmentally acceptable refrigerant as a tracer for leak test procedures. Use dry nitrogen to raise the machine pressure to leak testing levels.

TESTING WITHOUT REFRIGERANT TRACER

Another method of leak testing is to pressurize with nitrogen only and to use a soap bubble solution or an ultrasonic leak detector to determine if leaks are present.

TO PRESSURIZE WITH DRY NITROGEN

NOTE: Pressurizing with dry nitrogen for leak testing should not be done if the full refrigerant charge is in the vessel because purging the nitrogen is very difficult.

1. Connect a copper tube from the pressure regulator on the cylinder to the refrigerant charging valve. Never apply full cylinder pressure to the pressurizing line. Follow the listed sequence.
2. Open the charging valve fully.
3. Slowly open the cylinder regulating valve.
4. Observe the pressure gage on the chiller and close the regulating valve when the pressure reaches test level. *Do not exceed* maximum allowable test pressure 45 psig (310 kPa) for units marked 57 MAWP (maximum allowable working pressure) to allow for plenty of margin to avoid from bursting the rupture discs.
5. Close the charging valve on the chiller. Remove the copper tube if it is no longer required.

Repair Leaks, Retest, Standing Vacuum Test

After pressurizing the chiller, test for leaks with an electronic halide leak detector, soap bubble solution, or ultrasonic leak detector. Bring the chiller back to atmospheric pressure, repair any leaks found, and retest.

After retesting and finding no leaks, apply a standing vacuum test. Then dehydrate the chiller. Refer to the Standing Vacuum Test and Chiller Dehydration sections (pages 22 and 24) in the Before Initial Start-Up section.

Checking Guide Vanes

During normal shutdown, when the chiller is off, the guide vanes are closed. Complete the following steps to adjust position if required (see Fig. 43 and 44):

1. Remove the set screw in the guide vane coupling.
2. Loosen the holddown bolts on the guide vane actuator.
3. Pull the guide vane actuator away from the suction housing.
4. If required, rotate the guide vane shaft fully clockwise for first stage and counterclockwise for second stage and spot-drill the guide vane actuator shaft. Spot-drilling is necessary when the guide vane actuator sprocket set screws on the guide vane actuator shaft need to be re-seated. (Remember: Spot-drill and tighten the first set screw before spot-drilling for the second set screw.)

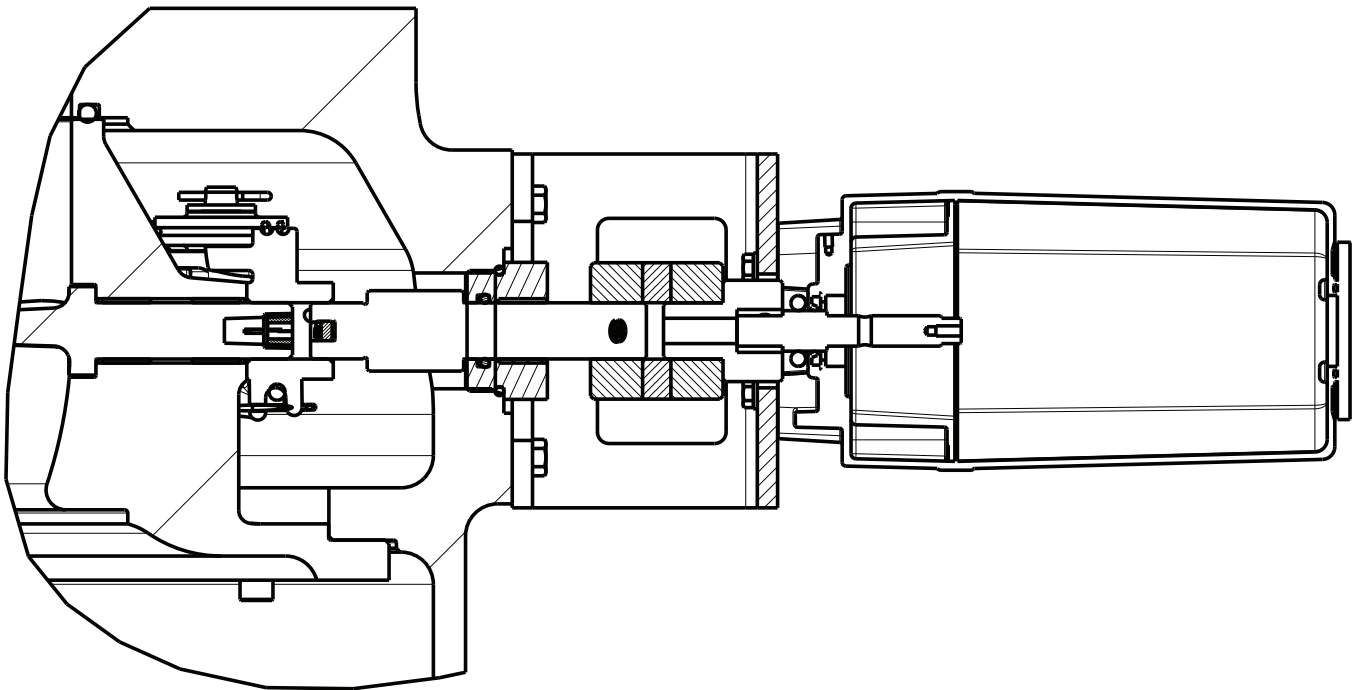
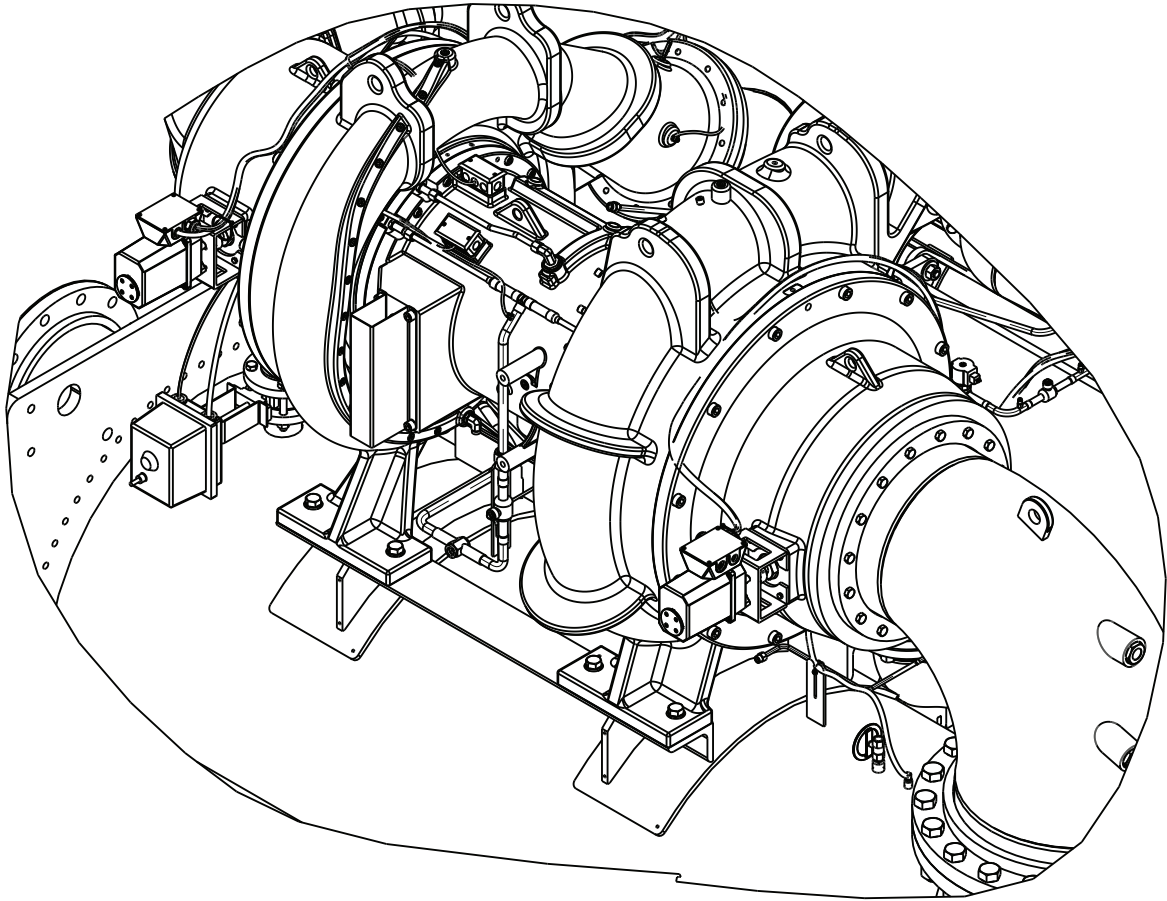
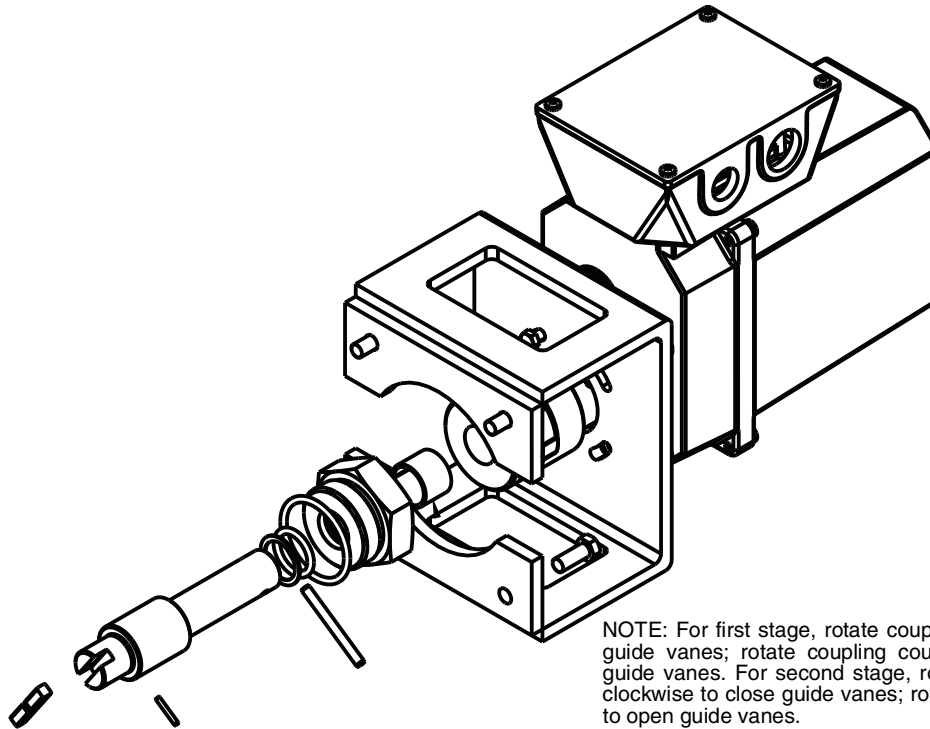

Fig. 43 — Guide Vane Actuator



NOTE: For first stage, rotate coupling clockwise to close guide vanes; rotate coupling counterclockwise to open guide vanes. For second stage, rotate coupling counterclockwise to close guide vanes; rotate coupling clockwise to open guide vanes.

Fig. 44 — Guide Vane Actuator Detail

Trim Refrigerant Charge

If to obtain optimal chiller performance it becomes necessary to adjust the refrigerant charge, operate the chiller at design load and then add or remove refrigerant slowly until the difference between the leaving chilled water temperature and the evaporator refrigerant temperature reaches design conditions or becomes a minimum. *Do not overcharge.* Use evaporator sight glasses to visually determine optimum charge. At steady state full load operation the evaporator tubes, as viewed in the boiling pool section of the evaporator, should be covered with liquid refrigerant — if tubes are covered, maximum efficiency is achieved and there is no benefit of additional refrigerant.

Refrigerant may be added either through the storage tank or directly into the chiller as described in the Charge Unit with Refrigerant section on page 28.

To remove any excess refrigerant, follow the procedure in Transfer Refrigerant from Chiller to Storage Tank Vessel section on page 45.

WEEKLY MAINTENANCE

Check the Refrigerant Lubrication System

1. Enter Input Status menu and verify that Liquid Level Switch is closed (if compressor is on).
2. Check moisture indicating sight glass on bearing supply line (Fig. 45) as well as on the motor/VFD liquid cooling line (located between vessels feeding of the high side float chamber; sight glass is located downstream of filter drier).
3. Check that pressure Ref Pump Delta P (PRESSURE Menu is above 12 psig [82.7 kPa]).

Check for Leaks

Frequent purge pumpout operation is an indication of a leak. When the daily pumpout limit is exceeded, the controls will show process Alert 148 — Purge Daily Pumpout Limit Exceeded. If no alert, the purge run-time for the past 24 hours as well as the past 7 days can be obtained from RUNTIME menu.

SCHEDULED MAINTENANCE

Establish a regular maintenance schedule based on your actual chiller requirements such as chiller load, run hours, and water quality. *The time intervals listed in this section are offered as guides to service only.*

Service Ontime

The HMI will display resettable “After Service Hrs”, “Total Pumpout Numbers”, and “Total Pumpout Time” values on the *Main Menu → Run Times* screen. These values should be reset to zero by the service person or the operator each time major service work is completed so that the time between service events can be viewed and tracked. Previous values and associated dates should be logged for future reference prior to resetting.

Inspect the Control Panel

Maintenance consists of general cleaning and tightening of connections. Vacuum the control cabinets to eliminate dust build-up. If the chiller control malfunctions, refer to the Troubleshooting Guide section on page 51 for control checks and adjustments.

⚠ WARNING

Ensure power to the starter is isolated when cleaning and tightening connections inside the starter enclosure. Failure to disconnect power could result in electrocution.

Inspect the Purge

Enter 19DV Quick Test menu to test purge function. Functions available for Quick Test verification are Purge Condenser CV, Purge Comp SV, Pumpout SV, Drainage SV, Regen SV, Discharge SV, Idle Drain SV, Vacuum Pump, Purge Compressor, and Purge Heater. Turn on Purge Compressor and verify that it runs. Open/close all valves using the Quick Test menu. Clean the condenser coil as required and replace the strainer as needed.

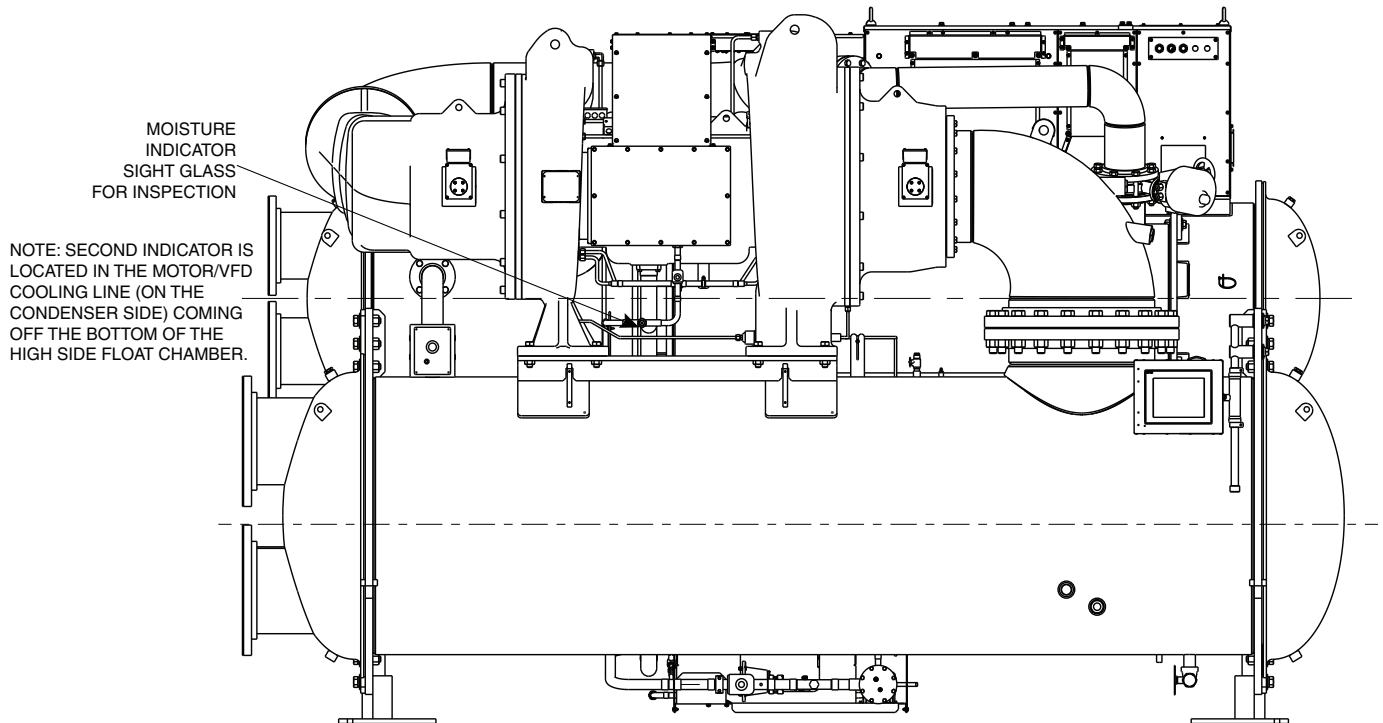

Fig. 45 — Moisture Indicator Sight Glass for inspection

Changing Refrigerant Lubrication Filters

Change the refrigerant lubrication filter, motor cooling filter, and bearing filter on an annual basis or when the chiller is opened for repairs. The filters can be isolated so they can be changed with refrigerant remaining in the chiller. Strainers such as 2x refrigerant pump suction strainers, inhibitor reclaim, and inductor are to be replaced every 5 years or as required when the machine is open for service. These filters do not contain desiccant for moisture removal so changing the filter will not change the moisture indicator status.

Change strainers/filters by closing isolation valves and slowly opening the flare fitting with a wrench and back-up wrench to relieve pressure.

Inspect Refrigerant Float System

Perform this inspection only if the following symptoms are seen:

- There is a simultaneous drop in evaporator pressure and increase in condenser pressure. This will be accompanied by an increase in kW/Ton.
 - The liquid line downstream of the float valve feels warm and float valve seems stuck based on a visual inspection through the end cover sight glass. This indicates condenser gas flowing past the float.
1. Transfer the refrigerant into a pumpout storage tank.
 2. Remove the float access cover.
 3. Clean the chamber and valve assembly thoroughly. Be sure the valve moves freely. Ensure that all openings are free of obstructions.
 4. Examine the cover gasket and replace if necessary.

This applies for both the high side float (first float downstream of condenser) and the low side float (second float downstream of condenser). The float refrigerant level can be observed through the two sight glasses located on the float cover under the condenser. See Fig. 46 for float detail. Inspect the float every five years. Clean the chamber and the float valve assembly. Be sure that the float moves freely and the ball bearings that the float moves on are clean.

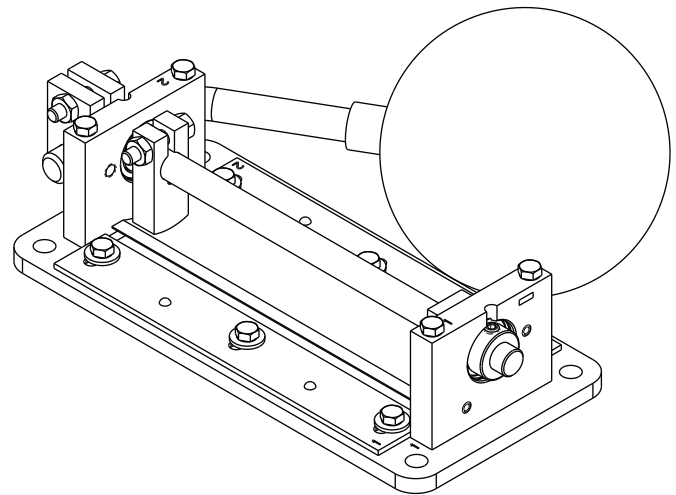

Fig. 46 — Float System

Inspect Safety Relief Devices and Piping

The relief device on this chiller protects the system against the potentially dangerous effects of overpressure. To ensure against damage to the equipment and possible injury to personnel, these devices must be kept in peak operating condition.

As a minimum, the following maintenance is required.

1. At least once a year, disconnect the vent piping at the valve outlet and carefully inspect the rupture disk for any evidence of internal corrosion or rust, dirt, scale, leakage, etc. Verify that vent piping has a section leaning away from valve to avoid the valve outlet becoming a trap for dirt, condensation etc.
2. If corrosion or foreign material is found, do not attempt to repair or recondition. *Replace the safety relief device.*
3. If the chiller is installed in a corrosive atmosphere or the relief devices are vented into a corrosive atmosphere, inspect the safety relief devices at more frequent intervals.

Compressor Bearing Maintenance

The key to good bearing maintenance is proper lubrication. Inspect the lubrication system regularly and thoroughly. Annual vibration measurements are recommended to monitor overall compressor status. Annual refrigerant analysis is recommended to monitor refrigerant acid and moisture levels over time.

Excessive bearing wear can often be detected through increased vibration or increased bearing temperature. To inspect the bearings, a complete compressor teardown is required. Only a trained service technician should perform a compressor disassembly. Bearings cannot be field inspected; excessive vibration is the primary sign of wear or damage. If either symptom appears, contact an experienced and responsible service organization for assistance. Annual compressor vibration analysis and trending is recommended for compressor preventative monitoring and maintenance.

⚠ CAUTION

If compressor requires disassembly, cleanliness is of critical importance to avoid contamination. Small amounts of contamination can result in damage to ceramic bearings.

Inspect Heat Exchanger Tubes and Flow Devices

EVAPORATOR AND OPTIONAL FLOW DEVICES

Inspect and clean the evaporator tubes at the end of the first operating season. Because these tubes have internal ridges, a rotary-type tube cleaning system is needed to fully clean the tubes. Inspect the tubes' condition to determine the scheduled frequency for future cleaning and to determine whether water treatment in the chilled water/brine circuit is adequate. Inspect the entering and leaving chilled water temperature sensors and flow devices for signs of corrosion or scale. Replace a sensor or Schrader fitting if corroded or remove any scale if found.

CONDENSER AND OPTIONAL FLOW DEVICES

Since this water circuit is usually an open-type system, the tubes may be subject to contamination and scale. Clean the condenser tubes with a rotary tube cleaning system at least once per year and more often if the water is contaminated. Inspect the entering and leaving condenser water sensors and flow devices for signs of corrosion or scale. Replace the sensor or Schrader fitting if corroded or remove any scale if found.

Higher than normal condenser pressures, together with the inability to reach full refrigeration load, usually indicate dirty tubes or air in the chiller. If the refrigeration log indicates a rise above normal condenser pressures, check the condenser refrigerant temperature against the leaving condenser water temperature. If this reading is more than what the design difference is supposed to be, the condenser tubes may be dirty, water flow may be incorrect, or non-condensables have contaminated the refrigerant circuit. To resolve, check the purge status. If purge is operating normally and does not have excessive run time, that may be an indication to double check pressure transducer and temperature readings along with flow.

During the tube cleaning process, use brushes specially designed to avoid scraping and scratching the tube wall. Contact your Carrier representative to obtain these brushes. Do not use wire brushes. Hard scale may require chemical treatment for its prevention or removal. Consult a water treatment specialist for proper treatment.

Water Leaks

The refrigerant moisture indicator on the refrigerant motor cooling line along with the moisture indicator located in the liquid refrigerant feeding the compressor bearings (Fig. 2) indicates whether there is water or air leakage during chiller operation. Water leaks should be repaired immediately.

⚠ CAUTION

The chiller must be dehydrated after repair of water leaks or damage may result. See Chiller Dehydration section, page 24.

Water Treatment

Untreated or improperly treated water may result in corrosion, scaling, erosion, or algae. The services of a qualified water treatment specialist should be obtained to develop and monitor a treatment program.

⚠ CAUTION

Water must be within design flow limits, clean, and treated to ensure proper chiller performance and reduce the potential of tube damage due to corrosion, scaling, erosion, and algae. Carrier assumes no responsibility for chiller damage resulting from untreated or improperly treated water. If the unit is going to be stored for an extended period of time, Carrier has specific long-term storage requirements that are documented and available from the chiller sales group.

Inspect the VFD

Before working on any starter, shut off the chiller, then open and tag all disconnects supplying power to the starter.

⚠ CAUTION

The motor leads must be disconnected from the VFD before an insulation test is performed. The voltage generated from the tester can damage the drive components.

⚠ CAUTION

Failure to follow these procedures may result in personal injury or damage to equipment.

TO AVOID an electric shock hazard, verify that the voltage on the bus capacitors has discharged completely before servicing. Check the DC bus voltage at the power terminal block by measuring between the +DC and -DC terminals, between the +DC terminal and the chassis, and between the -DC terminal and the chassis. The voltage must be zero for all three measurements.

⚠ WARNING

DC bus capacitors retain hazardous voltages after input power has been disconnected. An isolated multimeter will be needed to measure DC bus voltage and to make resistance checks.

After disconnecting input power, wait 5 minutes for the DC bus capacitors to discharge and then check the voltage with a voltmeter rated for the DC bus voltage to ensure the DC bus capacitors are discharged before touching any internal components. Failure to observe this precaution could result in severe bodily injury or loss of life.

⚠ WARNING

The disconnect on the starter front panel does not always de-energize all internal circuits. Open all internal and remote disconnects before servicing the starter. Failure to follow this procedure may result in personal injury by electric shock.

Periodically vacuum accumulated debris on the internal parts. Use electrical cleaner for electrical parts as required. Perform visual inspection of the capacitors located on the DC bus and inductors. Check cooling fan operation. Check condensate drain for the VFD enclosure.

Power connections on newly installed starters may relax and loosen after a short period of operation. Turn power off and re-tighten. Recheck annually thereafter.

⚠ CAUTION

Loose power connections can cause voltage spikes, overheating, malfunctioning, or failures.

Recalibrate Pressure Transducers

Once a year, the pressure transducers should be checked against a pressure gage reading. Check all pressure transducers: evaporator pressure, condenser pressure, refrigerant pump inlet pressure, refrigerant pump outlet pressure, bearing inlet pressure, bearing outlet pressure, and optional evaporator entering and leaving water pressure, as well as condenser entering and leaving water pressure. See Fig. 34.

Recalibrate Temperature Thermistors

Entering chilled water (ECW), leaving chilled water (LCW), entering condenser water (ECDW), leaving condenser water (LCDW).

Ordering Replacement Chiller Parts

When ordering Carrier specified parts, the following information must accompany an order:

- chiller model number and serial number
- name, quantity, and part number of the part required
- delivery address and method of shipment.

TROUBLESHOOTING GUIDE

Overview

The PIC6 control system has many features to help the operator and technician troubleshoot a 19DV chiller.

- The HMI shows the chiller's actual operating conditions and can be viewed while the unit is running.
- The HMI default screen indicates when an alarm occurs. Once all alarms have been cleared (by correcting the problems), the HMI default screen indicates normal operation. For information about displaying and resetting alarms and a list of alert codes, see the 19DV with PIC6 Controls Operation and Troubleshooting manual.
- The Configuration menu screens display information that helps to diagnose problems with chilled water temperature control, chilled water temperature control overrides, hot gas bypass, surge algorithm status, and time schedule operation.
- The quick test and quick calibration feature facilitates the proper operation and test of temperature sensors, pressure transducers, the guide vane actuator, refrigerant pump, water pumps, tower control, and other on/off outputs while the compressor is stopped. It also has the ability to lock off

the compressor and turn on water pumps for pumpout operation (Maintenance Menu). The HMI shows the temperatures and pressures required during these operations.

- If an operating fault is detected, an alarm indicator is displayed on the HMI default screen. A more detailed message — along with a diagnostic message — is also stored in the Current Alarms table.
- Review the Alarms History table to view other less critical events which may have occurred. Compare timing of relevant events and alarms.

For detailed information about alarms, see the 19DV with PIC6 Controls Operation and Troubleshooting manual. Press the bell icon in the top right corner of the home screen to access current alarms and alarm history, and to reset alarms.

Checking Display Messages

The first area to check when troubleshooting the 19DV is the HMI display. Status messages are displayed at the bottom of the screen, and the alarm icon indicates a fault. For a complete list of alarms, see the 19DV with PIC6 Controls Operation and Troubleshooting manual.

Checking Temperature Sensors

All temperature sensors are thermistor-type sensors. This means that the resistance of the sensor varies with temperature. All sensors have the same resistance characteristics. If the controls are on, determine sensor temperature by measuring voltage drop; if the controls are powered off, determine sensor temperature by measuring resistance. Compare the readings to the values listed in Tables 18 and 19.

RESISTANCE CHECK

Turn off the control power and, from the module, disconnect the terminal plug of the sensor in question. With a digital ohmmeter, measure sensor resistance between receptacles as designated by the wiring diagram. The resistance and corresponding temperature are listed in Tables 18 and 19. Check the resistance of both wires to ground. This resistance should be infinite.

VOLTAGE DROP

The voltage drop across any energized sensor can be measured with a digital voltmeter while the control is energized. Tables 18 and 19 list the relationship between temperature and sensor voltage drop (volts dc measured across the energized sensor). Exercise care when measuring voltage to prevent damage to the sensor leads, connector plugs, and modules. Sensors should also be checked at the sensor plugs.

⚠ CAUTION

Relieve all refrigerant pressure or drain the water before removing any thermowell threaded into the refrigerant pressure boundary. Failure to do so could result in personal injury and equipment damage.

Table 18 — Thermistor Temperature (F) vs. Resistance/Voltage Drop

TEMPERATURE (F)	PIC VOLTAGE DROP (V)	RESISTANCE (OHMS)	TEMPERATURE (F)	PIC VOLTAGE DROP (V)	RESISTANCE (OHMS)	TEMPERATURE (F)	PIC VOLTAGE DROP (V)	RESISTANCE (OHMS)
-25	4.700	97,706	66	2.565	6,568	157	0.630	893
-24	4.690	94,549	67	2.533	6,405	158	0.619	876
-23	4.680	91,474	68	2.503	6,246	159	0.609	859
-22	4.670	88,480	69	2.472	6,092	160	0.599	843
-21	4.659	85,568	70	2.440	5,942	161	0.589	827
-20	4.648	82,737	71	2.409	5,796	162	0.579	812
-19	4.637	79,988	72	2.378	5,655	163	0.570	797
-18	4.625	77,320	73	2.347	5,517	164	0.561	782
-17	4.613	74,734	74	2.317	5,382	165	0.551	768
-16	4.601	72,229	75	2.287	5,252	166	0.542	753
-15	4.588	69,806	76	2.256	5,124	167	0.533	740
-14	4.576	67,465	77	2.227	5,000	168	0.524	726
-13	4.562	65,205	78	2.197	4,880	169	0.516	713
-12	4.549	63,027	79	2.167	4,764	170	0.508	700
-11	4.535	60,930	80	2.137	4,650	171	0.499	687
-10	4.521	58,915	81	2.108	4,539	172	0.491	675
-9	4.507	56,981	82	2.079	4,432	173	0.484	663
-8	4.492	55,129	83	2.050	4,327	174	0.476	651
-7	4.477	53,358	84	2.021	4,225	175	0.468	639
-6	4.461	51,669	85	1.993	4,125	176	0.460	628
-5	4.446	50,062	86	1.965	4,028	177	0.453	616
-4	4.429	48,536	87	1.937	3,934	178	0.445	605
-3	4.413	47,007	88	1.909	3,843	179	0.438	595
-2	4.396	45,528	89	1.881	3,753	180	0.431	584
-1	4.379	44,098	90	1.854	3,667	181	0.424	574
0	4.361	42,715	91	1.827	3,582	182	0.418	564
1	4.344	41,380	92	1.800	3,500	183	0.411	554
2	4.325	40,089	93	1.773	3,420	184	0.404	544
3	4.307	38,843	94	1.747	3,342	185	0.398	535
4	4.288	37,639	95	1.721	3,266	186	0.392	526
5	4.269	36,476	96	1.695	3,192	187	0.385	516
6	4.249	35,354	97	1.670	3,120	188	0.379	508
7	4.229	34,270	98	1.644	3,049	189	0.373	499
8	4.209	33,224	99	1.619	2,981	190	0.367	490
9	4.188	32,214	100	1.595	2,914	191	0.361	482
10	4.167	31,239	101	1.570	2,849	192	0.356	474
11	4.145	30,298	102	1.546	2,786	193	0.350	466
12	4.123	29,389	103	1.523	2,724	194	0.344	458
13	4.101	28,511	104	1.499	2,663	195	0.339	450
14	4.079	27,663	105	1.476	2,605	196	0.333	442
15	4.056	26,844	106	1.453	2,547	197	0.328	435
16	4.033	26,052	107	1.430	2,492	198	0.323	428
17	4.009	25,285	108	1.408	2,437	199	0.318	421
18	3.985	24,544	109	1.386	2,384	200	0.313	414
19	3.960	23,826	110	1.364	2,332	201	0.308	407
20	3.936	23,130	111	1.343	2,282	202	0.304	400
21	3.911	22,455	112	1.321	2,232	203	0.299	393
22	3.886	21,800	113	1.300	2,184	204	0.294	387
23	3.861	21,163	114	1.279	2,137	205	0.290	381
24	3.835	20,556	115	1.259	2,092	206	0.285	374
25	3.808	19,967	116	1.239	2,047	207	0.281	368
26	3.782	19,396	117	1.219	2,003	208	0.277	362
27	3.755	18,843	118	1.200	1,961	209	0.272	356
28	3.727	18,307	119	1.180	1,920	210	0.268	351
29	3.700	17,787	120	1.161	1,879	211	0.264	345
30	3.672	17,284	121	1.143	1,840	212	0.260	339
31	3.644	16,797	122	1.124	1,801	213	0.256	334
32	3.617	16,325	123	1.106	1,764	214	0.252	329
33	3.588	15,868	124	1.088	1,727	215	0.248	323
34	3.559	15,426	125	1.070	1,691	216	0.245	318
35	3.530	14,997	126	1.053	1,656	217	0.241	313
36	3.501	14,582	127	1.036	1,622	218	0.237	308
37	3.471	14,181	128	1.019	1,589	219	0.234	303
38	3.442	13,791	129	1.002	1,556	220	0.230	299
39	3.412	13,415	130	0.986	1,524	221	0.227	294
40	3.382	13,050	131	0.969	1,493	222	0.224	289
41	3.353	12,696	132	0.953	1,463	223	0.220	285
42	3.322	12,353	133	0.938	1,433	224	0.217	280
43	3.291	12,021	134	0.922	1,404	225	0.214	276
44	3.260	11,699	135	0.907	1,376	226	0.211	272
45	3.229	11,386	136	0.893	1,348	227	0.208	267
46	3.198	11,082	137	0.878	1,321	228	0.205	263
47	3.167	10,787	138	0.864	1,295	229	0.203	259
48	3.135	10,500	139	0.849	1,269	230	0.198	255
49	3.104	10,221	140	0.835	1,244	231	0.195	251
50	3.074	9,949	141	0.821	1,219	232	0.192	248
51	3.042	9,689	142	0.808	1,195	233	0.190	244
52	3.010	9,436	143	0.795	1,172	234	0.187	240
53	2.978	9,190	144	0.782	1,149	235	0.184	236
54	2.946	8,951	145	0.769	1,126	236	0.182	233
55	2.914	8,719	146	0.756	1,104	237	0.179	229
56	2.882	8,494	147	0.744	1,083	238	0.176	226
57	2.850	8,275	148	0.731	1,062	239	0.174	223
58	2.819	8,062	149	0.719	1,041	240	0.172	219
59	2.788	7,855	150	0.707	1,021	241	0.169	216
60	2.756	7,655	151	0.696	1,002	242	0.167	213
61	2.724	7,460	152	0.684	983	243	0.164	210
62	2.692	7,271	153	0.673	964	244	0.162	207
63	2.660	7,088	154	0.662	945	245	0.160	204
64	2.628	6,909	155	0.651	928	246	0.158	201
65	2.596	6,736	156	0.640	910	247	0.155	198
						248	0.153	195

Table 19 — Thermistor Temperature (C) vs. Resistance/Voltage Drop

TEMPERATURE (C)	PIC VOLTAGE DROP (V)	RESISTANCE (OHMS)	TEMPERATURE (C)	PIC VOLTAGE DROP (V)	RESISTANCE (OHMS)
-33	4.722	105 616	44	1.338	2 272
-32	4.706	99 640	45	1.300	2 184
-31	4.688	93 928	46	1.263	2 101
-30	4.670	88 480	47	1.227	2 021
-29	4.650	83 297	48	1.192	1 944
-28	4.630	78 377	49	1.158	1 871
-27	4.608	73 722	50	1.124	1 801
-26	4.586	69 332	51	1.091	1 734
-25	4.562	65 205	52	1.060	1 670
-24	4.538	61 343	53	1.029	1 609
-23	4.512	57 745	54	0.999	1 550
-22	4.486	54 411	55	0.969	1 493
-21	4.458	51 341	56	0.941	1 439
-20	4.429	48 536	57	0.913	1 387
-19	4.399	45 819	58	0.887	1 337
-18	4.368	43 263	59	0.861	1 290
-17	4.336	40 858	60	0.835	1 244
-16	4.303	38 598	61	0.811	1 200
-15	4.269	36 476	62	0.787	1 158
-14	4.233	34 484	63	0.764	1 117
-13	4.196	32 613	64	0.741	1 079
-12	4.158	30 858	65	0.719	1 041
-11	4.119	29 211	66	0.698	1 006
-10	4.079	27 663	67	0.677	971
-9	4.037	26 208	68	0.657	938
-8	3.994	24 838	69	0.638	906
-7	3.951	23 545	70	0.619	876
-6	3.906	22 323	71	0.601	846
-5	3.861	21 163	72	0.583	818
-4	3.814	20 083	73	0.566	791
-3	3.765	19 062	74	0.549	765
-2	3.716	18 097	75	0.533	740
-1	3.667	17 185	76	0.518	715
0	3.617	16 325	77	0.503	692
1	3.565	15 513	78	0.488	670
2	3.512	14 747	79	0.474	648
3	3.459	14 023	80	0.460	628
4	3.406	13 341	81	0.447	608
5	3.353	12 696	82	0.434	588
6	3.298	12 087	83	0.422	570
7	3.242	11 510	84	0.410	552
8	3.185	10 963	85	0.398	535
9	3.129	10 444	86	0.387	518
10	3.074	9 949	87	0.376	502
11	3.016	9 486	88	0.365	487
12	2.959	9 046	89	0.355	472
13	2.901	8 628	90	0.344	458
14	2.844	8 232	91	0.335	444
15	2.788	7 855	92	0.325	431
16	2.730	7 499	93	0.316	418
17	2.672	7 160	94	0.308	405
18	2.615	6 839	95	0.299	393
19	2.559	6 535	96	0.291	382
20	2.503	6 246	97	0.283	371
21	2.447	5 972	98	0.275	360
22	2.391	5 711	99	0.267	349
23	2.335	5 463	100	0.260	339
24	2.280	5 226	101	0.253	330
25	2.227	5 000	102	0.246	320
26	2.173	4 787	103	0.239	311
27	2.120	4 583	104	0.233	302
28	2.067	4 389	105	0.227	294
29	2.015	4 204	106	0.221	286
30	1.965	4 028	107	0.215	278
31	1.914	3 861	108	0.210	270
32	1.865	3 701	109	0.205	262
33	1.816	3 549	110	0.198	255
34	1.768	3 404	111	0.193	248
35	1.721	3 266	112	0.188	242
36	1.675	3 134	113	0.183	235
37	1.629	3 008	114	0.178	229
38	1.585	2 888	115	0.174	223
39	1.542	2 773	116	0.170	217
40	1.499	2 663	117	0.165	211
41	1.457	2 559	118	0.161	205
42	1.417	2 459	119	0.157	200
43	1.377	2 363	120	0.153	195

CHECK SENSOR ACCURACY

Place the sensor in a medium of known temperature and compare that temperature to the measured reading. The thermometer used to determine the temperature of the medium should be of laboratory quality with 0.5°F (0.25°C) graduations. The sensor in question should be accurate to within 2°F (1.2°C).

Note that the PIC6 control module, MAINTENANCE menu, offers a temperature sensor calibration feature where the sensor temperature can be offset. Note that only the four water temperatures can be calibrated. To use this feature, place the sensor at 32°F (0°C) or other known temperature. Read the raw temperature and calculate offset based on the reading seen in the TEMP_CAL menu. Enter and execute the offset, which cannot exceed $\pm 2^\circ\text{F}$ (1.2°C).

See Fig. 2 for sensor locations. The sensors are immersed directly in the refrigerant or water circuits. When installing a new sensor, apply a pipe sealant or thread sealant to the sensor threads.

An additional thermistor, factory installed in the bottom of the evaporator barrel, is displayed as Evap Refrig Liquid Temp on the TEMPERATURES display screen. This thermistor provides additional protection against a loss of water flow.

DUAL TEMPERATURE SENSORS

For servicing convenience, there are 2 redundant sensors each on the bearing and motor temperature sensors. If one of the sensors is damaged, the other can be used by simply moving a wire. The number 2 terminal in the sensor terminal box is the common line. To use the second sensor, move the wire from the number 1 position to the number 3 position. See Fig. 47 or Fig. 48.

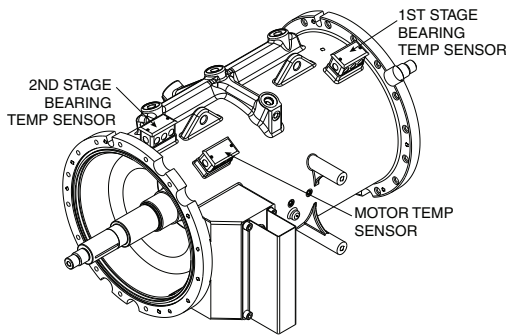

Fig. 47 — Motor Housing Temperature Sensors

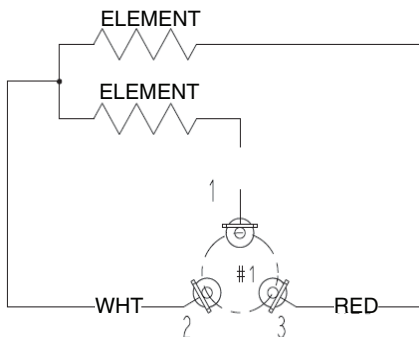

Fig. 48 — First and Second Stage Bearing Temperature Wiring and Motor Thermistor Wiring

Checking Pressure Transducers

There are 6 factory-installed pressure transducers measuring refrigerant pressure: condenser pressure, evaporator pressure, refrigerant pump suction, discharge pressure, bearing inlet pressure, and bearing outlet pressure.

These transducers can be calibrated if necessary. It is necessary to calibrate at initial start-up, particularly at high altitude locations, to ensure the proper refrigerant temperature/pressure relationship. Each transducer is supplied with 5 vdc power. If the

power supply fails, a transducer voltage reference alarm occurs. If the transducer reading is suspected of being faulty, check the 5V Sensor Power Monitor voltage. It should be 5 vdc \pm 0.5 v as displayed in *Maintenance Menu* → *Maintenance Others*, where all the transducer voltages are shown. Recalibrate and replace the transducer if correct voltage is being supplied, but displayed values are incorrect. Additionally, check that any external inputs have not been grounded.

TRANSDUCER REPLACEMENT

All transducers except the compressor high pressure switch (located on discharge pipe) are mounted on Schrader-type fittings. Transducers installed on Schrader-type fittings can be removed without the need to remove refrigerant from the vessel when replacing the transducers. Disconnect the transducer wiring. *Do not pull on the transducer wires.* Unscrew the transducer from the Schrader fitting. When installing a new transducer, do not use pipe sealer (which can plug the sensor). Put the plug connector back on the sensor and snap into place. Check for refrigerant leaks.

⚠ WARNING

Be sure to use a back-up wrench on the Schrader fitting whenever removing a transducer, since the Schrader fitting may back out with the transducer, causing a large leak and possible injury to personnel.

EVAPORATOR, CONDENSER, REFRIGERANT PUMP SUCTION AND DISCHARGE, BEARING INLET AND OUTLET PRESSURE TRANSDUCER CALIBRATION

Calibration can be checked by comparing the pressure readings from the transducer to an accurate refrigeration gage reading. These readings can be viewed or calibrated from the HMI screen. The transducer can be checked and calibrated at 2 pressure points. These calibration points are 0 psig (0 kPa) and between 10 and 30 psig (69 and 207 kPa). Connect pressure transducer to Schrader connection. To calibrate these transducers:

1. Shut down compressor, evaporator, and condenser pumps.
- NOTE: There should be no flow through the heat exchangers.
2. Disconnect transducer in question from its Schrader fitting for evaporator or condenser transducer calibration. For other pressure or flow device calibration, leave transducer in place.

NOTE: If the evaporator or condenser vessels are at 0 psig (0 kPa) or are open to atmospheric pressure, the transducers can be calibrated for zero without removing the transducer from the vessel.

3. Access the PRESSURE or (if water side pressure) HYDRAULIC STATUS screen and view the particular transducer reading. To calibrate pressure or waterside flow device, view the particular reading. It should read 0 psig (0 kPa). If the reading is not 0 psig (0 kPa), but within ± 5 psig (35 kPa), the value may be set to zero from the Maintenance Menu while the appropriate transducer parameter is highlighted. The value will now go to zero.
4. If the transducer value is not within the calibration range, the transducer returns to the original reading. If the pressure is within the allowed range (noted above), check the voltage ratio of the transducer. To obtain the voltage ratio, divide the voltage (dc) input from the transducer by the supply voltage signal or measure across the positive (+ red) and negative (– black) leads of the transducer. The input to reference voltage ratio must be between 0.80 and 0.11 for the software to allow calibration. Rotate the waterside flow pressure device from the inlet nozzle to the outlet nozzle and repeat this step. If rotating the waterside flow device does not allow calibration, pressurize the transducer until the ratio is within range. Then attempt calibration again.

- Installation of pressure transducers into water nozzles using flushable dirt leg trap is suggested; see Fig. 49. Pressures can be calibrated between 100 and 250 psig (689.5 and 1723.7 kPa) by attaching a regulated 250 psig (1724 kPa) pressure (usually from a nitrogen cylinder). For calibration, access the Pressure Sensor Calibration Menu from the Maintenance Menu and calibrate the appropriate sensor.

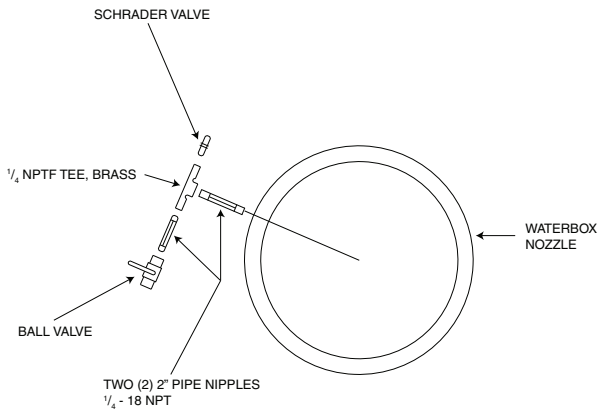

Fig. 49 — Suggested Installation of Pressure Transducers into Water Nozzles Using Flushable Dirt Leg Trap

The PIC6 control system does not allow calibration if the transducer is too far out of calibration. In this case, a new transducer must be installed and re-calibrated.

High Altitude Locations

Because the chiller is initially calibrated at sea level, it is necessary to recalibrate the pressure transducers if the chiller has been moved to a high altitude location. Note that Atmospheric Pressure can be adjusted in the Service Parameters Menu (located in the Configuration Menu).

Quick Test and 19DV Quick Test

The Quick Test feature is located in the Main Menu. Use this feature to test chiller status, test the status of various actuators, view water temperature deltas, and test pump and relays, as well as EC (Envelope Control) valve, alarms, condenser, and chilled water pumps. The tests can help to determine whether a switch is defective or a pump relay is not operating, as well as other useful troubleshooting issues.

Quick Calibration

Use this menu to calibrate IGVs, and EC valve if it has feedback.

Physical Data

Tables 20-28 and Fig. 50-72 provide additional information on component weights, compressor fits and clearances, physical and electrical data, and wiring schematics for the operator's convenience during troubleshooting.

Table 20 — Component Weights

COMPONENT	DV3 COMPRESSOR		DV4 COMPRESSOR	
	lb	kg	lb	kg
SUCTION PIPE ASSEMBLY (INCLUDES FLANGES)	421	191	569	258
INTERSTAGE PIPING (SECTION ONLY FROM FLANGE TO FLANGE)	350	159	1000	454
DISCHARGE PIPING	5	3	5	3
HMI PANEL	24	11	24	11
CONTROL PANEL	190	86	190	86
HIGH SIDE FLOAT CHAMBER COVER	64	29	50	23
LOW SIDE FLOAT CHAMBER COVER	64	29	50	23
PURGE ASSEMBLY	263	119	263	119
ENVELOP CONTROL VALVE	30	14	97	44
ECONOMIZER BYPASS VALVE	30	14	121	55
FREE COOLING VALVE	62	28	184	84
FREE COOLING PIPE	88	40	478	217
ECONOMIZER VENT LINE ISOLATION VALVE (OPTION)	55	28	62	28
ECONOMIZER VENT LINE PIPING	92	44	151	69
VFD 32VSS0680	1354	614	—	—
VFD 32VSS0850	—	—	1650	748
VFD PULLBOX	184	84	184	84
VFD ACTIVE HARMONIC FILTER	332	151	332	151
VFD CABLE	200	91	200	91
VFD TRAY	124	57	124	57

Table 21 — 19DV Compressor and Motor Weights* — High-Efficiency Motors

DV3						
MOTOR CODE	ENGLISH			SI		
	COMPRESSOR WEIGHT† (lb)	STATOR AND HOUSING WEIGHT (lb)	ROTOR AND SHAFT WEIGHT (lb)	COMPRESSOR WEIGHT† (kg)	STATOR AND HOUSING WEIGHT (kg)	ROTOR AND SHAFT WEIGHT (kg)
Voltage: 380/460						
B	5605	926	242	2542	420	110
D	5605	926	242	2542	420	110
F	5605	1041	281	2542	472	127
H	5605	1093	302	2542	496	137
DV4						
Voltage: 380/460						
B	6195	1090	330	2810	494	150
D	6195	1150	340	2810	522	154
F	6195	1230	350	2810	558	159
H	6195	1316	364	2810	597	165

* Total compressor weight is the sum of the compressor aerodynamic components (compressor weight column), stator, rotor, and end bell cover weights.

† Compressor aerodynamic component weight only, motor weight not included. Applicable to standard compressors only.

Table 22 — 19DV Heat Exchanger Weights (English)

CODE†	DRY RIGGING WEIGHT (LB)*		REFRIGERANT WEIGHT (LB)		WATER WEIGHT (LB)	
	EVAPORATOR ONLY	CONDENSER ONLY	EVAPORATOR ONLY	CONDENSER ONLY	EVAPORATOR ONLY	CONDENSER ONLY
F20	7272	—	570	—	1311	—
F21	7376	—	577	—	1359	—
F22	7529	6127	586	311	1432	1156
F23	7684	6356	595	319	1504	1248
F24	7837	6534	605	326	1577	1321
F25	7287	—	570	—	1290	—
F26	7399	—	577	—	1342	—
F27	7536	5999	586	311	1408	1008
F28	7691	6189	595	319	1480	1085
F29	7845	6398	605	326	1553	1170
F40	7856	—	653	—	1384	—
F41	7975	—	660	—	1440	—
F42	8151	6625	671	386	1522	1259
F43	8330	6888	682	395	1605	1365
F44	8506	7092	693	403	1688	1447
F45	7865	—	653	—	1361	—
F46	7993	—	660	—	1420	—
F47	8151	6476	671	386	1495	1103
F48	8329	6695	682	395	1578	1191
F49	8506	6934	693	403	1660	1288
F2A	6972	—	570	—	1346	—
F2B	7072	—	577	—	1414	—
F2C	7169	5666	586	288	1481	1222
F2D	7269	5796	595	292	1548	1300
F2E	7372	5975	605	298	1615	1405
F2F	6972	—	570	—	1306	—
F2G	7062	—	577	—	1367	—
F2H	7169	5548	586	288	1441	1054
F2J	7261	5678	595	292	1501	1132
F2K	7379	5866	605	298	1582	1243
F4A	7513	—	653	—	1425	—
F4B	7629	—	660	—	1502	—
F4C	7741	6099	671	349	1578	1335
F4D	7857	6249	682	354	1655	1423
F4E	7975	6455	693	361	1731	1543
F4F	7505	—	653	—	1380	—
F4G	7608	—	660	—	1448	—
F4H	7733	5961	671	349	1532	1156
F4J	7838	6111	682	354	1601	1244
F4K	7975	6328	693	361	1693	1371
G20	8611	—	700	—	1723	—
G21	8772	—	700	—	1799	—
G22	8942	6713	700	413	1879	1332
G23	9111	6956	700	405	1959	1430
G24	9330	7222	700	402	2063	1539
G25	8677	—	700	—	1695	—
G26	8802	—	700	—	1754	—
G27	8972	6669	700	413	1834	1245
G28	9147	6884	700	405	1917	1333
G29	9339	7140	700	402	2007	1437
G40	9260	—	840	—	1808	—
G41	9446	—	840	—	1895	—
G42	9641	7275	840	468	1986	1453
G43	9836	7555	840	458	2076	1566
G44	10088	7860	840	455	2195	1689
G45	9326	—	840	—	1780	—
G46	9470	—	840	—	1847	—
G47	9665	7220	840	468	1938	1363
G48	9867	7467	840	458	2032	1463
G49	10087	7760	840	455	2135	1581
G2A	8225	—	700	—	1740	—
G2B	8324	—	700	—	1807	—
G2C	8433	6198	700	413	1881	1424
G2D	8540	6402	700	405	1952	1544
G2E	8699	6585	700	397	2059	1653
G2F	8236	—	700	—	1675	—
G2G	8331	—	700	—	1739	—
G2H	8450	6180	700	413	1819	1340

Table 22 — 19DV Heat Exchanger Weights (English) (cont)

CODE†	DRY RIGGING WEIGHT (LB)*		REFRIGERANT WEIGHT (LB)		WATER WEIGHT (LB)	
	EVAPORATOR ONLY	CONDENSER ONLY	EVAPORATOR ONLY	CONDENSER ONLY	EVAPORATOR ONLY	CONDENSER ONLY
G2J	8580	6359	700	405	1907	1446
G2K	8710	6504	700	397	1994	1532
G4A	8818	—	840	—	1827	—
G4B	8933	—	840	—	1904	—
G4C	9059	6688	840	468	1988	1558
G4D	9182	6922	840	458	2068	1696
G4E	9365	7133	840	448	2191	1819
G4F	8821	—	840	—	1757	—
G4G	8931	—	840	—	1830	—
G4H	9068	6663	840	468	1922	1471
G4J	9218	6869	840	458	2021	1591
G4K	9368	7036	840	448	2121	1690
H20	9572	—	741	—	2127	—
H21	9755	—	752	—	2213	—
H22	9936	7933	763	484	2298	1726
H23	10177	8253	778	495	2412	1856
H24	10420	8601	792	507	2527	1996
H25	9518	—	741	—	2101	—
H26	9697	—	752	—	2185	—
H27	9906	7815	763	484	2284	1678
H28	10115	8125	778	495	2383	1803
H29	10356	8450	792	507	2497	1936
H40	10315	—	841	—	2235	—
H41	10526	—	853	—	2334	—
H42	10734	8618	866	484	2430	1882
H43	11011	8985	883	495	2560	2029
H44	11291	9384	900	507	2690	2189
H45	10253	—	841	—	2205	—
H46	10459	—	853	—	2302	—
H47	10700	8482	866	563	2414	1827
H48	10940	8837	883	576	2527	1969
H49	11218	9211	900	590	2657	2121
H2A	9025	—	700	—	2111	—
H2B	9149	—	707	—	2195	—
H2C	9294	7294	716	431	2293	1852
H2D	9453	7532	726	439	2400	1991
H2E	9623	7791	736	448	2514	2143
H2F	8990	—	700	—	2088	—
H2G	9115	—	707	—	2172	—
H2H	9253	7210	716	431	2266	1802
H2J	9402	7425	726	439	2363	1929
H2K	9568	7675	736	448	2477	2075
H4A	9692	—	795	—	2218	—
H4B	9835	—	803	—	2313	—
H4C	10002	7889	813	499	2424	2025
H4D	10185	8163	824	508	2546	2183
H4E	10381	8461	836	518	2676	2356
H4F	9652	—	795	—	2191	—
H4G	9795	—	803	—	2286	—
H4H	9956	7792	813	499	2393	1969
H4J	10126	8040	824	508	2504	2113
H4K	10318	8327	836	518	2634	2279

* Rigging weights are for standard Super B5LSL and Super C5 tubes of standard wall thickness (0.025-in. [0.635 mm] wall) and do not include refrigerant weight.

† See Model Number Nomenclature.

NOTES:

1. Evaporator weight includes two-pass Victaulic dished heads.
2. Condenser weight includes the high side float chamber, discharge pipe, and two-pass Victaulic dished heads; does not include economizer weight.

Table 23 — 19DV Heat Exchanger Weights (SI)

CODE†	DRY RIGGING WEIGHT (KG)*		REFRIGERANT WEIGHT (KG)		WATER WEIGHT (KG)	
	EVAPORATOR ONLY	CONDENSER ONLY	EVAPORATOR ONLY	CONDENSER ONLY	EVAPORATOR ONLY	CONDENSER ONLY
F20	3299	—	259	—	595	—
F21	3346	—	262	—	616	—
F22	3415	2779	266	141	650	524
F23	3485	2883	270	145	682	566
F24	3555	2964	274	148	715	599
F25	3305	—	259	—	585	—
F26	3356	—	262	—	609	—
F27	3418	2721	266	141	639	457
F28	3489	2807	270	145	671	492
F29	3558	2902	274	148	704	531
F40	3563	—	296	—	628	—
F41	3617	—	299	—	653	—
F42	3697	3005	304	175	690	571
F43	3778	3124	309	179	728	619
F44	3858	3217	314	183	766	656
F45	3568	—	296	—	617	—
F46	3626	—	299	—	644	—
F47	3697	2937	304	175	678	500
F48	3778	3037	309	179	716	540
F49	3858	3145	314	183	753	584
F2A	3162	—	259	—	611	—
F2B	3208	—	262	—	641	—
F2C	3252	2570	266	131	672	554
F2D	3297	2629	270	132	702	590
F2E	3344	2710	274	135	733	637
F2F	3162	—	259	—	592	—
F2G	3203	—	262	—	620	—
F2H	3252	2517	266	131	654	478
F2J	3294	2575	270	132	681	513
F2K	3347	2661	274	135	718	564
F4A	3408	—	296	—	646	—
F4B	3460	—	299	—	681	—
F4C	3511	2766	304	158	716	606
F4D	3564	2834	309	161	751	645
F4E	3617	2928	314	164	785	700
F4F	3404	—	296	—	626	—
F4G	3451	—	299	—	657	—
F4H	3508	2704	304	158	695	524
F4J	3555	2772	309	161	726	564
F4K	3617	2870	314	164	768	622
G20	3906	—	318	—	782	—
G21	3979	—	318	—	816	—
G22	4056	3045	318	187	852	604
G23	4133	3155	318	184	889	649
G24	4232	3276	318	182	936	698
G25	3936	—	318	—	769	—
G26	3993	—	318	—	796	—
G27	4070	3025	318	187	832	565
G28	4149	3123	318	184	870	605
G29	4236	3239	318	182	910	652
G40	4200	—	381	—	820	—
G41	4285	—	381	—	860	—
G42	4373	3300	381	212	901	659
G43	4462	3427	381	208	942	710
G44	4576	3565	381	206	996	766
G45	4230	—	381	—	807	—
G46	4296	—	381	—	838	—
G47	4384	3275	381	212	879	618
G48	4476	3387	381	208	922	664
G49	4575	3520	381	206	968	717
G2A	3731	—	318	—	789	—
G2B	3776	—	318	—	820	—
G2C	3825	2811	318	187	853	646
G2D	3874	2904	318	184	885	700
G2E	3946	2987	318	180	934	750
G2F	3736	—	318	—	760	—
G2G	3779	—	318	—	789	—

Table 23 — 19DV Heat Exchanger Weights (SI) (cont)

CODE†	DRY RIGGING WEIGHT (KG)*		REFRIGERANT WEIGHT (KG)		WATER WEIGHT (KG)	
	EVAPORATOR ONLY	CONDENSER ONLY	EVAPORATOR ONLY	CONDENSER ONLY	EVAPORATOR ONLY	CONDENSER ONLY
G2H	3833	2803	318	187	825	608
G2J	3892	2884	318	184	865	656
G2K	3951	2950	318	180	904	695
G4A	4000	—	381	—	829	—
G4B	4052	—	381	—	864	—
G4C	4109	3034	381	212	902	707
G4D	4165	3140	381	208	938	769
G4E	4248	3235	381	203	994	825
G4F	4001	—	381	—	797	—
G4G	4051	—	381	—	830	—
G4H	4113	3022	381	212	872	667
G4J	4181	3116	381	208	917	722
G4K	4249	3191	381	203	962	767
H20	4342	—	336	—	965	—
H21	4425	—	341	—	1004	—
H22	4507	3599	346	220	1042	783
H23	4616	3744	353	225	1094	842
H24	4726	3901	359	230	1146	905
H25	4317	—	336	—	953	—
H26	4399	—	341	—	991	—
H27	4493	3545	346	220	1036	761
H28	4588	3685	353	225	1081	818
H29	4698	3833	359	230	1133	878
H40	4679	—	381	—	1014	—
H41	4774	—	387	—	1058	—
H42	4869	3909	393	220	1102	853
H43	4995	4075	401	225	1161	920
H44	5121	4256	408	230	1220	993
H45	4651	—	381	—	1000	—
H46	4744	—	387	—	1044	—
H47	4853	3847	393	255	1095	829
H48	4962	4008	401	261	1146	893
H49	5088	4178	408	268	1205	962
H2A	4094	—	318	—	958	—
H2B	4150	—	321	—	996	—
H2C	4216	3308	325	195	1040	840
H2D	4288	3416	329	199	1089	903
H2E	4365	3534	334	203	1140	972
H2F	4078	—	318	—	947	—
H2G	4134	—	321	—	985	—
H2H	4197	3270	325	195	1028	818
H2J	4265	3368	329	199	1072	875
H2K	4340	3481	334	203	1124	941
H4A	4396	—	361	—	1006	—
H4B	4461	—	364	—	1049	—
H4C	4537	3578	369	226	1100	919
H4D	4620	3703	374	230	1155	990
H4E	4709	3838	379	235	1214	1069
H4F	4378	—	361	—	994	—
H4G	4443	—	364	—	1037	—
H4H	4516	3535	369	226	1086	893
H4J	4593	3647	374	230	1136	958
H4K	4680	3777	379	235	1195	1034

* Rigging weights are for standard Super B5LSL and Super C5 tubes of standard wall thickness (0.025-in. [0.635 mm] wall) and do not include refrigerant weight.
 † See Model Number Nomenclature.

NOTES:
 1. Evaporator weight includes two-pass Victaulic dished heads.
 2. Condenser weight includes the high side float chamber, discharge pipe, and two-pass Victaulic dished heads; does not include economizer weight.

Table 24 — 19DV Economizer Weight

COMPRESSOR SIZE	DRY WEIGHT (lb)*	REFRIGERANT WEIGHT (lb)	OPERATION WEIGHT (lb)	DRY WEIGHT (kg)*	REFRIGERANT WEIGHT (kg)	OPERATION WEIGHT (kg)
DV3	1501	227	1728	681	103	784
DV4	1931	342	2273	876	155	1031

* Includes standard economizer weight and all connecting piping to compressor.

Table 25 — Additional Weights for 19DV 150 psig (1034 kPa) Marine Waterboxes*† — English (lb)

FRAME	NUMBER OF PASSES	EVAPORATOR			CONDENSER		
		RIGGING WGT		WATER WGT	RIGGING WGT		WATER WGT
		VICTAULIC	FLANGE		VICTAULIC	FLANGE	
F	1	1154	1006	1086	922	846	682
	2	759	647	445	620	550	300
	3	1426	1316	936	1050	998	472
G	1	1221	1069	1174	612	498	1398
	2	864	716	607	449	373	558
	3	1533	1419	1001	848	778	1161
H	1	1517	1369	1131	815	703	1675
	2	941	793	597	672	560	802
	3	1659	1547	921	1080	1010	1395

* Add to evaporator and condenser weights for total weights. Evaporator and condenser weights may be found in Table 22. The first digit of the heat exchanger code (first column) is the heat exchanger frame size.

† Values are for Victaulic nozzles, two-pass dished head design.

Table 26 — Additional Weights for 19DV 150 psig (1034 kPa) Marine Waterboxes*† — SI (kg)

FRAME	NUMBER OF PASSES	EVAPORATOR			CONDENSER		
		RIGGING WGT		WATER WGT	RIGGING WGT		WATER WGT
		VICTAULIC	FLANGE		VICTAULIC	FLANGE	
F	1	523	456	493	418	384	309
	2	344	293	202	281	249	136
	3	647	597	425	476	453	214
G	1	554	485	533	278	226	634
	2	392	325	275	204	169	253
	3	695	644	454	385	353	527
H	1	688	621	513	370	319	760
	2	427	360	271	305	254	364
	3	753	702	418	490	458	633

* Add to evaporator and condenser weights for total weights. Evaporator and condenser weights may be found in Table 23. The first digit of the heat exchanger code (first column) is the heat exchanger frame size.

† Values are for Victaulic nozzles, two-pass dished head design.

Table 27 — 19DV Waterbox Cover Weights — English (lb)

WATERBOX DESCRIPTION	PASSES	EVAPORATOR						CONDENSER					
		FRAME F		FRAME G		FRAME H		FRAME F		FRAME G		FRAME H	
		Flanged	Victaulic	Flanged	Victaulic	Flanged	Victaulic	Flanged	Victaulic	Flanged	Victaulic	Flanged	Victaulic
NIH Dished Cover, 150 psig	1	406	328	494	417	515	437	191	154	232	172	249	187
	2	536	419	682	528	714	560	294	220	308	235	390	273
	2 return	315		404		424		134		154		168	
	3	459	401	557	499	588	529	212	186	247	210	268	232
MWB Flat Cover, 150 psig	1	426	352	668		759		293	255	138		172	
	2	509	397	668		759		381	311	172		214	
	2 return	315		404		422		134		154		168	
	3	411	356	668		759		259	233	172		215	

LEGEND

MWB — Marine Waterbox

NOTE: Weights for dished head cover and MWB end cover 150 psig are included in the heat exchanger weights shown in Table 22.

Table 28 — 19DV Waterbox Cover Weights — SI (kg)

WATERBOX DESCRIPTION	PASSES	EVAPORATOR						CONDENSER					
		FRAME F		FRAME G		FRAME H		FRAME F		FRAME G		FRAME H	
		Flanged	Victaulic	Flanged	Victaulic	Flanged	Victaulic	Flanged	Victaulic	Flanged	Victaulic	Flanged	Victaulic
NIH Dished Cover, 1034 kPa	1	184	149	224	189	234	198	87	70	105	78	113	85
	2	243	190	309	239	324	254	133	100	140	107	177	124
	2 return	143		183		192		61		70		76	
	3	208	182	253	226	267	240	96	84	112	95	122	105
MWB Flat Cover, 1034 kPa	1	193	160	303		344		133	116	63		78	
	2	231	180	303		344		173	141	78		97	
	2 return	143		183		191		61		70		76	
	3	186	161	303		344		117	106	78		98	

LEGEND

MWB — Marine Waterbox

NOTE: Weights for dished head cover and MWB end cover 1034 kPa are included in the heat exchanger weights shown in Table 23.

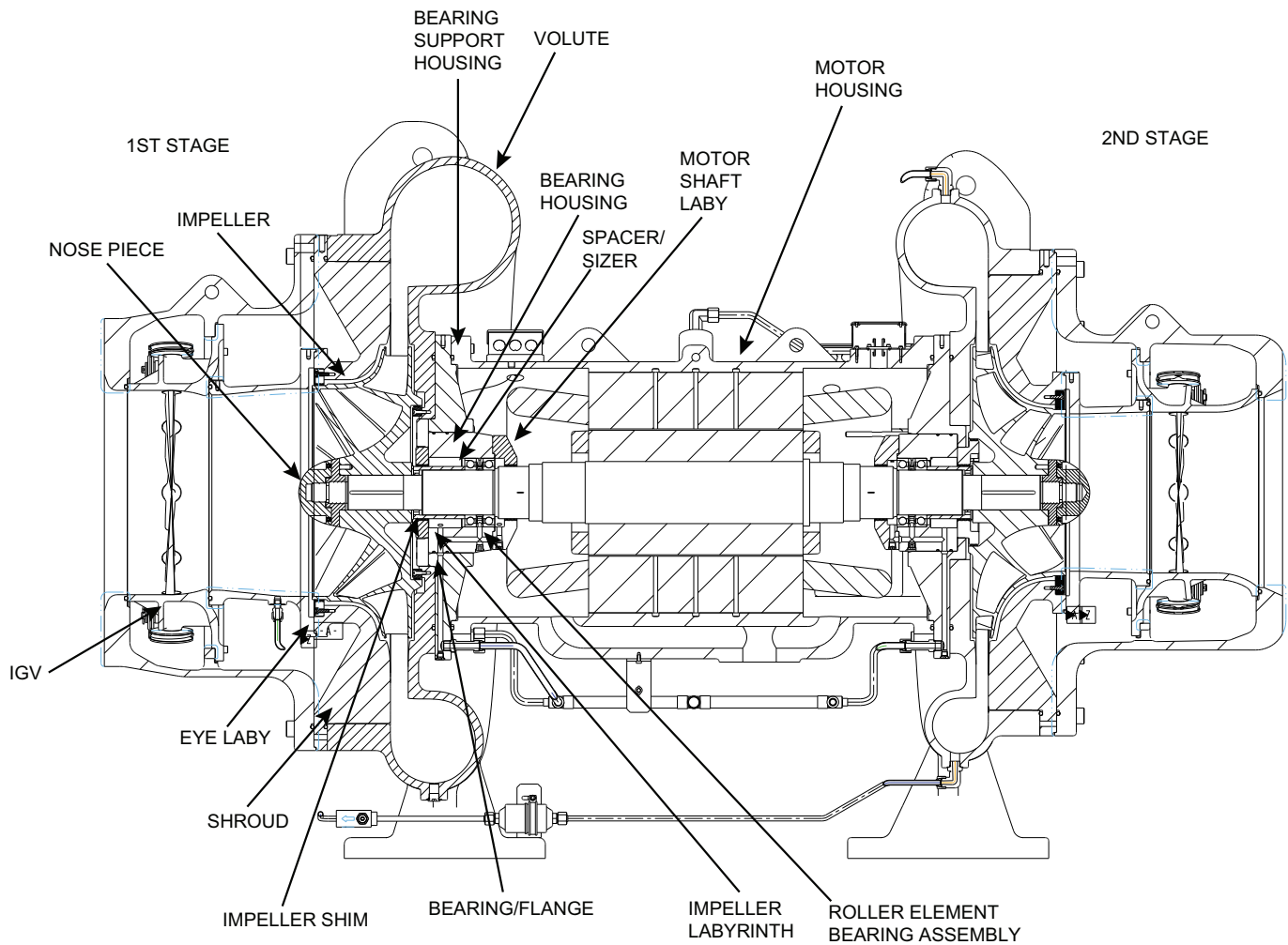

Fig. 50 — 19DV Compressor

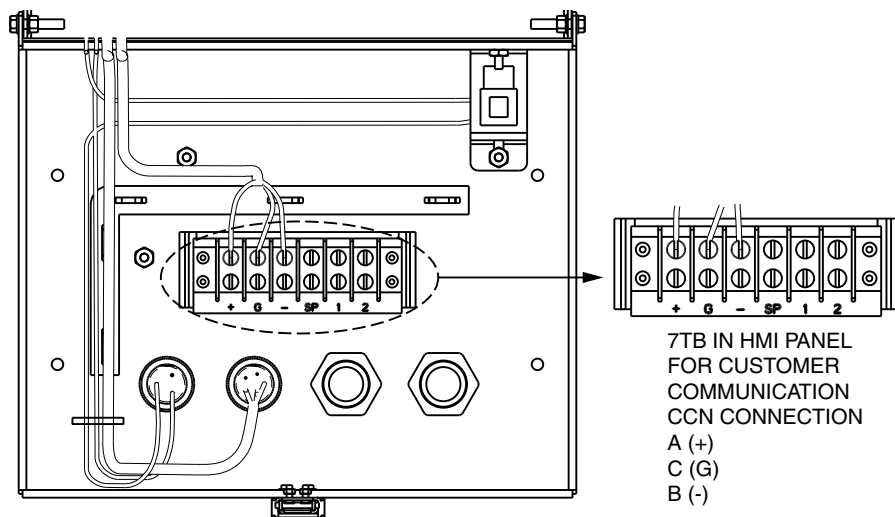

Fig. 51 — HMI Panel

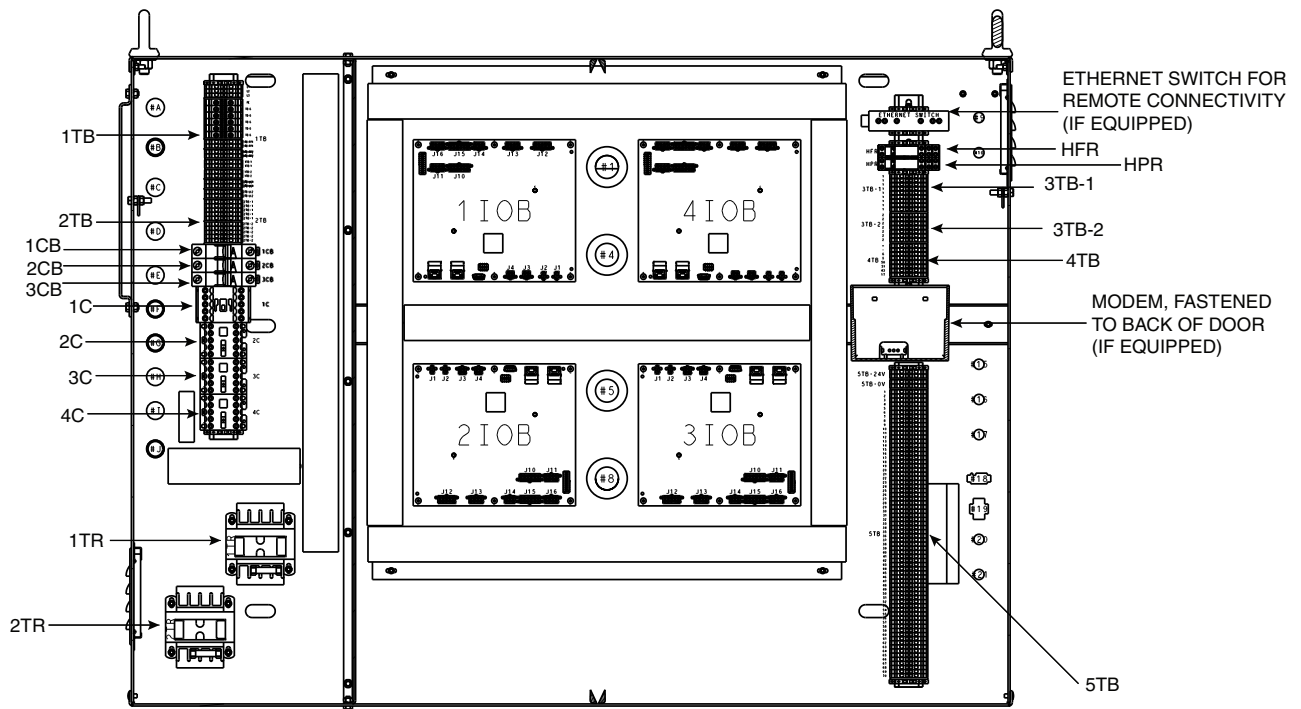

Fig. 52 — Control Panel

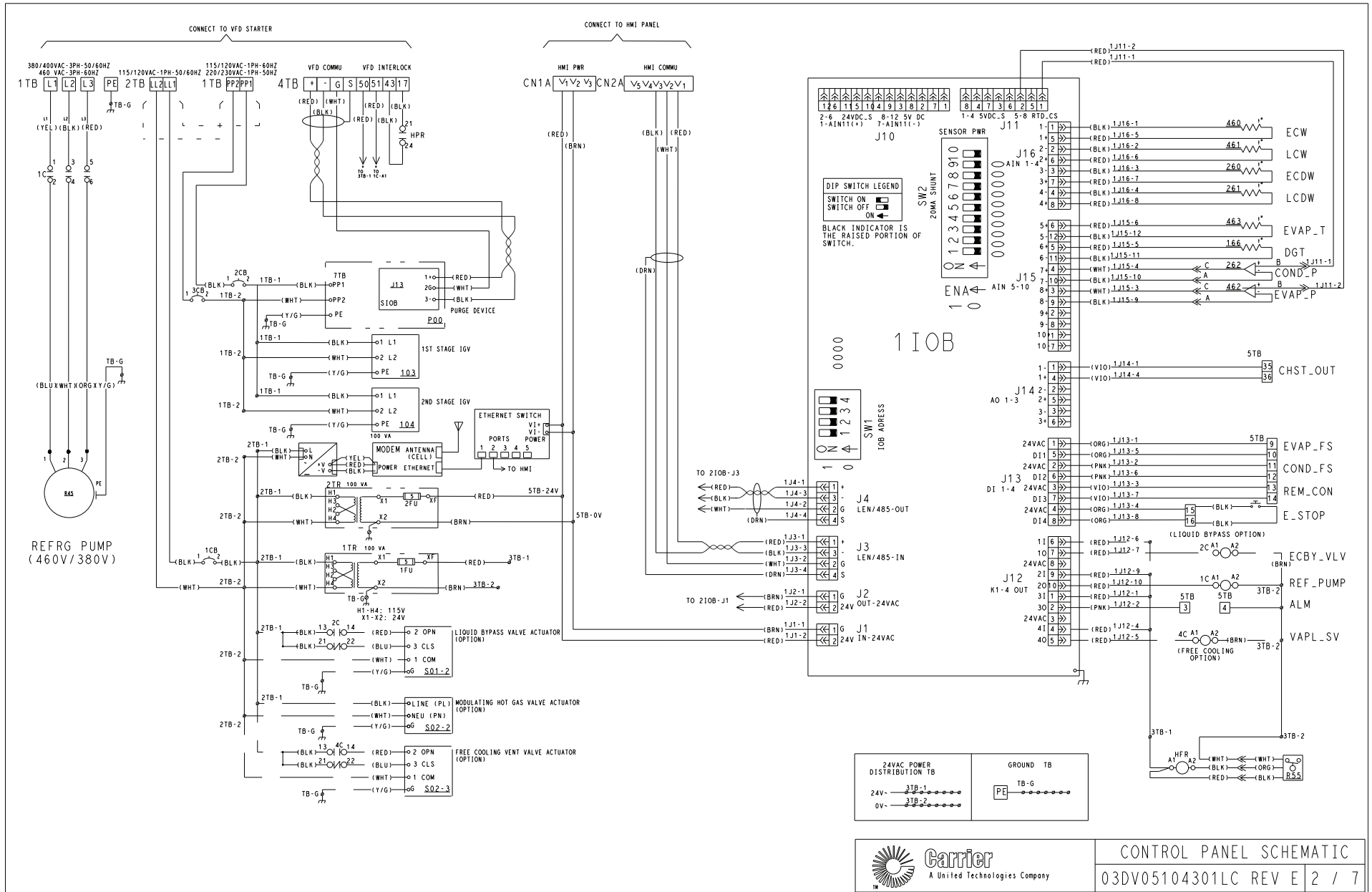

Fig. 53 — 19DV Input Output Board (IOB) Schematic

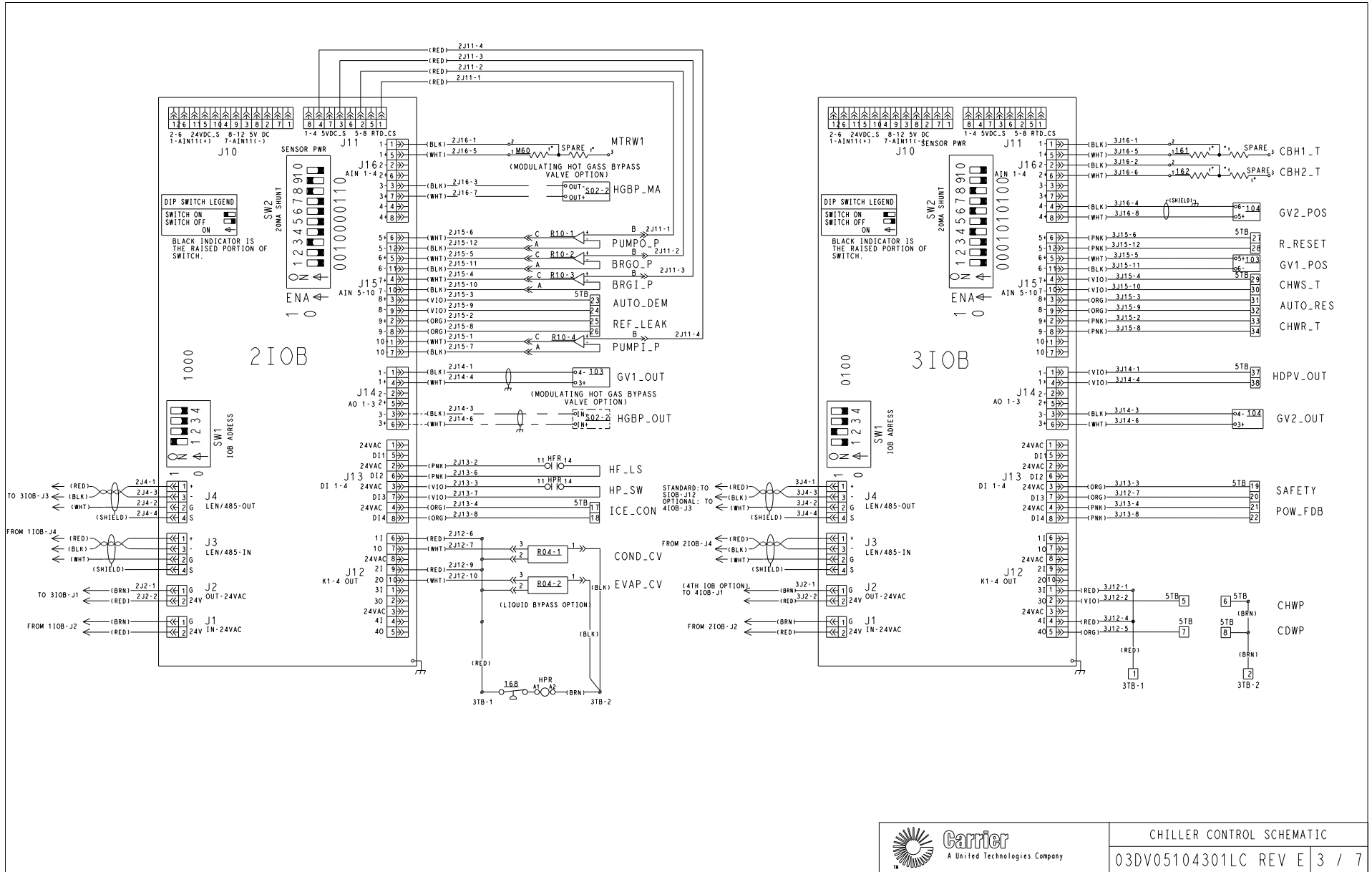
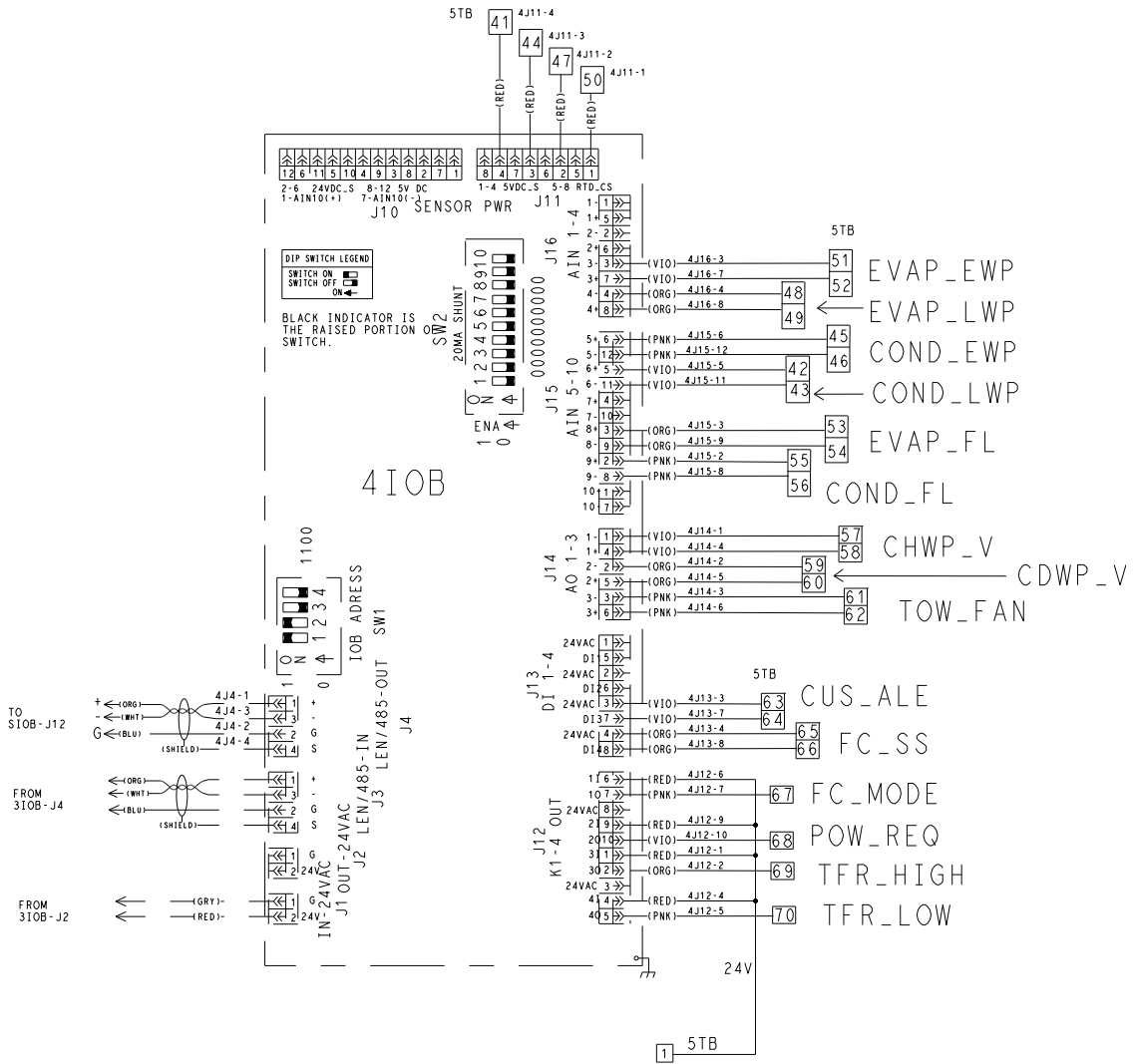

Fig. 53 — 19DV Input Output Board (IOB) Schematic (cont)



CHILLER CONTROL SCHEMATIC
03DV05104301LC REV E 3 / 7



THIS TYPICAL DRAWING SHOWS THE CARRIER STANDARD PRESSURE TRANSDUCER WHICH IS 5VDC POWER SUPPLY.

 Carrier A United Technologies Company	CONTROL PANEL SCHEMATIC	
	03DV05104301LC REV E	4 / 7

Fig. 53 — 19DV Input Output Board (IOB) Schematic (cont)

LEGEND FOR FIG. 53

Control Abbreviations

ALM	— Chiller Alarm
AUTO_DEM	— Demand Limit Input
AUTO_RES	— Auto Water Temp Reset
BRGI_P	— Bearing Inlet Pressure
BRGI_T	— Bearing Ref Supply Temp
BRGO_P	— Bearing Outlet Pressure
CBH1_T	— 1st Stage Bearing Temp
CBH2_T	— 2st Stage Bearing Temp
CDWP	— Condenser Water Pump
CDWP_V	— Condenser Water Pump (Variable Speed)
CHST_OUT	— Chiller Running (On/Off/Ready)
CHWP	— Chilled Water Pump
CHWP_V	— Chilled Water Pump (Variable Speed)
COND_CV	— Condenser Control Valve
COND_DCV	— Condenser Drain Valve
COND_EWP	— Entering Condenser Water Pressure
COND_FL	— Condenser Water Flow Measurement
COND_FS	— Condenser Water Flow Switch
COND_LWP	— Leaving Condenser Water Pressure
COND_P	— Condenser Pressure
CUS_ALE	— Customer Alert
DGT	— Compressor Discharge Temperature
ECBY_VLV	— Economizer Bypass Valve
ECDW	— Entering Condenser Water Temperature
ECON_IV	— Economizer Vent Valve Actuator
ECW	— Entering Chilled Water Temperature
EVAP_CV	— Evaporator Control Valve
EVAP_EWP	— Entering Evaporator Water Pressure
EVAP_FL	— Evaporator Water Flow Measurement
EVAP_FS	— Evaporator Water Flow Switch
EVAP_LWP	— Leaving Evaporator Water Pressure
EVAP_P	— Evaporator Pressure
EVAP_T	— Evaporator Refrigerant Temperature
FC_MODE	— Free Cooling Mode
FC_SS	— Free Cooling Start Switch
FS_LOCK	— Fire Alarm Interlock
GV1/2_OUT	— IGV 1/2 Output
GV1/2_POS	— IGV 1/2 Actual Position
HDPV_OUT	— Head Pressure Output
HGBP_MA	— Modulating Hot Gas Valve Feedback
HGBP_OUT	— Modulating Hot Gas Valve Output mA
HF_LS	— High Float Liquid Level Switch
HP_SW	— High Pressure Switch
ICE_CON	— Ice Build Contact
IGV	— Integrated Guide Vane
LCDW	— Leaving Condenser Water Temperature
LCW	— Leaving Chilled Water Temperature
MTRW1	— Motor Winding Temperature 1
PUMPI_P	— Pump Inlet Pressure
PUMPO_P	— Pump Outlet Pressure
REF_LEAK	— Refrigerant Leak Sensor
REF_PUMP	— Refrigerant Pump
REM_CON	— Remote Contact Input
TFR_HIGH	— Tower Fan High
TFR_LOW	— Tower Fan Low
TOW_FAN	— Tower Fan (Variable Speed)
VAPL_SV	— Vapor Venting Line SV











Instrument Code (Within Control Panel)

1C	— Refrigerant Pump Contactor
2C	— Liquid Bypass Valve Relay
3C	— Economizer Vent Valve Relay
4C	— Free Cooling Vent Valve Relay
1-3CB	— Micro Circuit Breaker
1FU	— Fuse, 5A, Time-Delay, 13/32" x 1-1/2"
2FU	— Fuse, 5A, Time-Delay, 13/32" x 1-1/2"
1-4 IOB	— 1-4 Input Output Board 1-4
1TB	— Terminal Block for Power Connection
2TB	— Internal 115/120-v Terminal Block
3TB	— Internal 24-v Terminal Block
4TB	— Terminal Block for VFD Connection
5TB	— Terminal Block for Customer Optional Connection
7TB	— 230/115-v Terminal Block (Purge Panel)
1TR	— Transformer 1 230/115-24-v 100 va
2TR	— Transformer 2 230/115-24-v 100 va
CN1A/B	— Connector for HMI Power
CN2A/B	— Connector for HMI Communication
HFR	— High Float Level Switch
HPR	— High Pressure Switch Relay
HMI	— HMI Touch Screen and Main Board SAIA
SIOB	— Standard Input Output Board (Purge Panel)
TB-G	— Copper Terminal Block for Ground

Instrument Code (Outside Control Panel)

103	— 1st Stage IGV
104	— 2nd Stage IGV
161	— 1st Bearing Temp Thermistor
162	— 2nd Bearing Temp Thermistor
166	— 2nd Stage Compressor Discharge Temp Thermistor
168	— High Pressure Switch
260	— Entering Condenser Water Temperature Thermistor
261	— Leaving Condenser Water Temperature Thermistor
262	— Condenser Pressure Transducer
460	— Entering Chilled Water Temperature Thermistor
461	— Leaving Chilled Water Temperature Thermistor
462	— Evaporator Pressure Transducer
463	— Evaporator Refrigerant Liquid Temp Thermistor
M60	— Motor Winding Temperature 1 (Thermistor/PT100)
P00	— Purge Device
R04-1	— Condenser Control Valve
R04-2	— Evaporator Control Valve
R10-1	— Refrigerant Pump Outlet Pressure Transducer
R10-2	— Bearing Outlet Pressure Transducer
R10-3	— Bearing Inlet Pressure Transducer
R10-4	— Refrigerant Pump Inlet Pressure Transducer
R15	— Bearing Ref Supply Temp Thermistor
R45	— Refrigerant Pump
R55	— High Float Liquid Level Switch
S01-2	— High Float Liquid Level Switch
S02-1	— Economizer Vent Valve Actuator
S02-2	— Modulating Hot Gas Control Valve Actuator
S02-3	— Free Cooling Vent Valve Actuator

Symbols

	Component Terminal
	Conductor Male/Female Connector
	Field Wiring
	Optional Wiring
	Component/Panel Enclosure
	Shield Wire
	Twisted Wire
	Terminal Block Connection
	Wire Splice or Junction
	Internal Terminal Block/Terminal

BLK	Black
BLU	Blue
BRN	Brown
GRN	Green
GRY	Gray
RED	Red
ORG	Orange
WHT	White
YEL	Yellow
G/Y	Green/Yellow

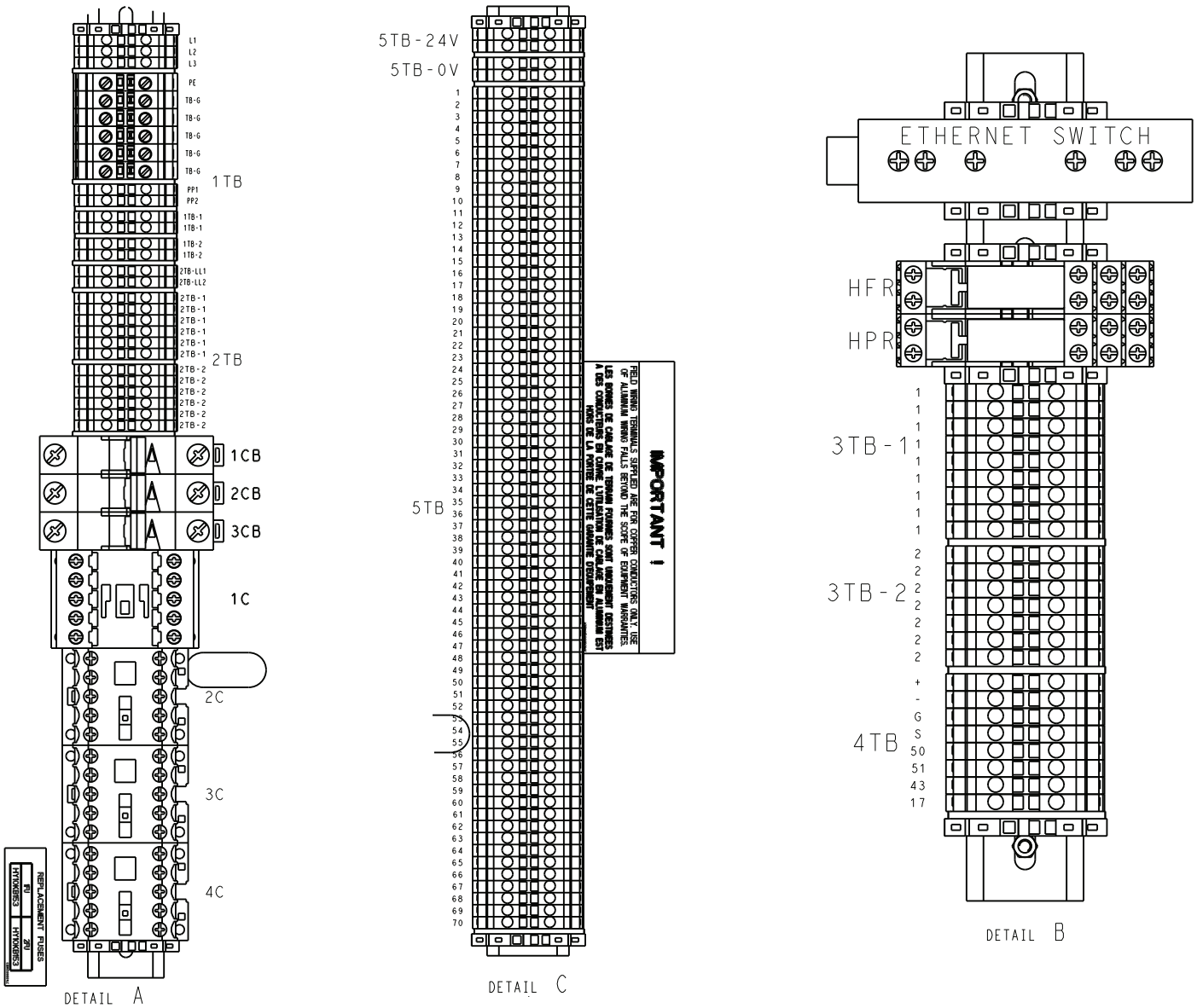

LEGEND

- 1C** — Refrigerant Pump Contactor
- 2C** — Liquid Bypass Valve Contactor (Option)
- 3C** — Economizer Vent Valve Contactor (Option)
- 4C** — Free Cooling Valve Contactor (Option)
- 1CB** — Control Power Circuit Breaker
- 2CB** — Control Power Circuit Breaker
- 1TB** — L1, L2, L3 – Main 3-Phase Power
- 1TB** — LL2, LL1 – 1-Phase Control Power
- 2TB** — Control Power Wiring Terminal Block
- 3TB** — 24 VAC Control Power Wiring Terminal Block
- 4TB** — VFD Communication and Interlock
- 5TB** — Customer Field Connection Terminal Block
- ETHERNET SWITCH** — Remote Connectivity Ethernet Connection
- HFR** — High Float Level Switch Relay
- HPR** — High Pressure Switch Relay

Fig. 54 — Chiller Control Schematic

FIELD OPTION WIRING INSTRUCTION OF CONTROL PANEL

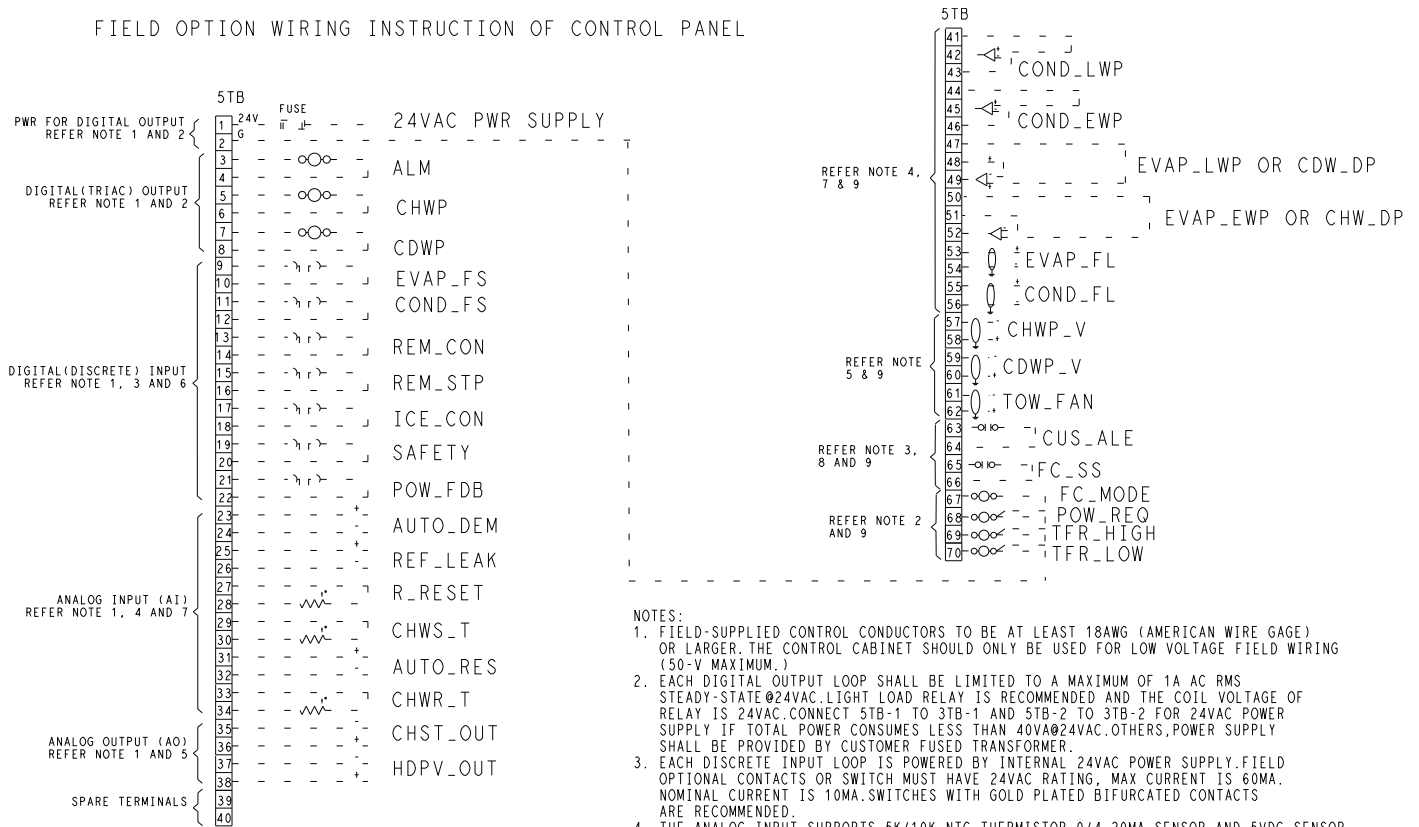

- NOTES:
1. FIELD-SUPPLIED CONTROL CONDUCTORS TO BE AT LEAST 18AWG (AMERICAN WIRE GAGE) OR LARGER. THE CONTROL CABINET SHOULD ONLY BE USED FOR LOW VOLTAGE FIELD WIRING (50-V MAXIMUM.)
 2. EACH DIGITAL OUTPUT LOOP SHALL BE LIMITED TO A MAXIMUM OF 1A AC RMS STEADY-STATE @24VAC. LIGHT LOAD RELAY IS RECOMMENDED AND THE COIL VOLTAGE OF RELAY IS 24VAC. CONNECT 5TB-1 TO 3TB-1 AND 5TB-2 TO 3TB-2 FOR 24VAC POWER SUPPLY IF TOTAL POWER CONSUMES LESS THAN 40VA@24VAC. OTHERS, POWER SUPPLY SHALL BE PROVIDED BY CUSTOMER FUSED TRANSFORMER.
 3. EACH DISCRETE INPUT LOOP IS POWERED BY INTERNAL 24VAC POWER SUPPLY. FIELD OPTIONAL CONTACTS OR SWITCH MUST HAVE 24VAC RATING, MAX CURRENT IS 60MA. NOMINAL CURRENT IS 10MA. SWITCHES WITH GOLD PLATED BIFURCATED CONTACTS ARE RECOMMENDED.
 4. THE ANALOG INPUT SUPPORTS 5K/10K NTC THERMISTOR, 0/4-20MA SENSOR AND 5VDC SENSOR.
 5. EACH ANALOG OUTPUT LOOP SUPPORTS 0/4-20MA OR 0/2-10VDC VOLTAGE OUTPUT. THE ANALOG OUTPUT LOOP IS POWERED BY BOARD. DO NOT SUPPLY EXTERNAL POWER.
 6. FOR STANDARD DISCRETE INPUT (ON 1/2/3IOB), ONLY WHEN THE CONTACT OR SWITCH IS CLOSED, AN ALARM WILL BE GENERATED.
 7. SW2 CONFIGURED BY FIELD, IF 4-20MA SIGNAL SENSOR, SHALL TURN THE SWITCH TO "ON" POSITION.
 8. FOR 4TH IOB DISCRETE INPUT, ONLY WHEN THE CONTACT OR SWITCH IS OPENED, AN ALARM WILL BE GENERATED.
 9. ALL CONNECTORS OF IOB, EXCEPT ETHERNET, SHALL SUPPORT 18AWG WIRE.

 Carrier A United Technologies Company	CONTROL PANEL SCHEMATIC	
	03DV05104301LC REV D	7 / 7

Fig. 55 — Control Panel Schematic



70

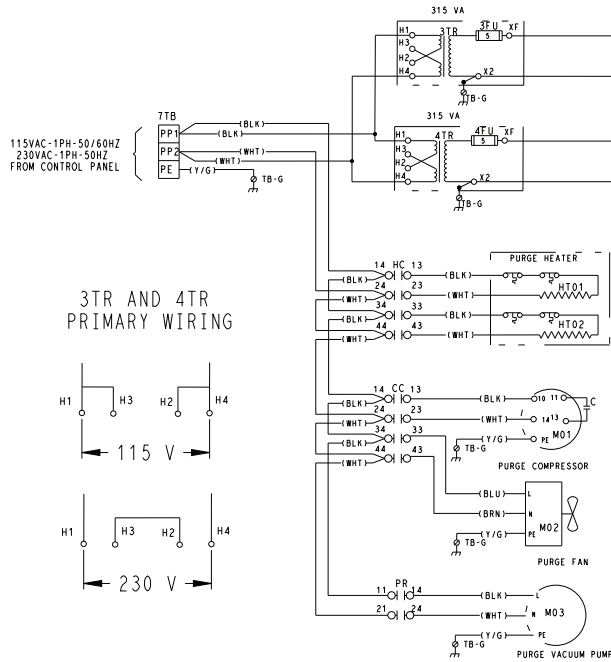
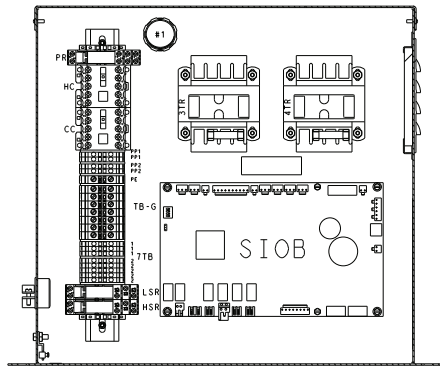

- NOTES:
1. ALL PRINTING TO BE BLACK ON WHITE BACKGROUND.
 2. LABEL TO BE PHOTOGRAPHICALLY REPRODUCED.
 3. MATERIAL: ADHESIVE BACKED LF31-83A
 4. TRANSFORMER JUMPERS SHOULD BE INSTALLED FOR 115V CONFIGURATION AT MANUFACTURER. CHARLOTTE FACTORY WILL CONFIGURE FOR 230V WHEN NECESSARY.

- LEGEND
- SV01 — Condenser Solenoid Valve
 - SV02 — Compressor Solenoid Valve
 - SV03 — Pumpout Solenoid Valve
 - SV04 — Drain Solenoid Valve
 - SV05 — Regeneration Solenoid Valve
 - SV06 — Vent Solenoid Valve
 - TS01 — Purge Compressor Inlet Temperature

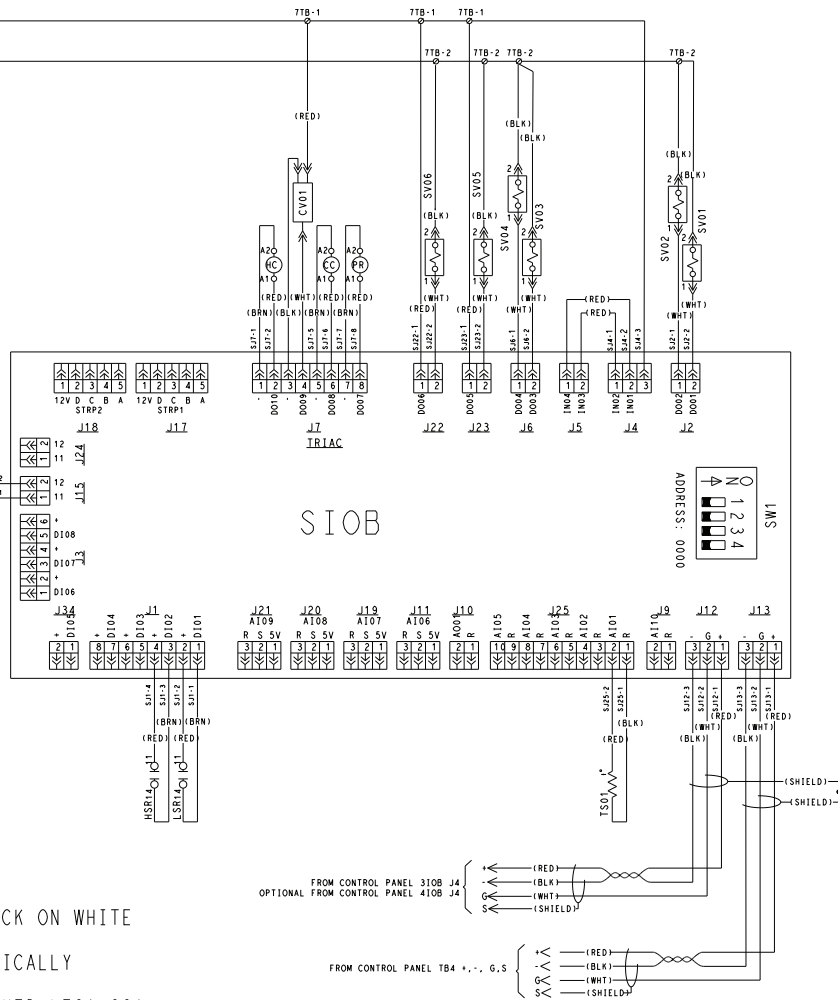

<p>Carrier A United Technologies Company</p>	PURGE PANEL SCHEMATIC
	03DV05104401LC REV E 1 / 1

Fig. 56 — Purge Schematic

- 1 — MAIN CIRCUIT BREAKER
- 2 — AC REACTOR
- 3 — DC REACTOR
- 4 — CURRENT TRANSFORMERS
- 5 — COOLING COIL AND FAN
- 6 — TRANSFORMER LOW VOLTAGE
- 7 — TRANSFORMER HIGH VOLTAGE
- 8 — DCIB CONTROL PANEL
- 9 — POWER SUPPLY CONTROL PANEL
- 10 — SERVICE PANEL
- 11 — RECTIFIER
- 12 — RECTIFIER FAN ASSEMBLY
- 13 — INVERTER
- 14 — INVERTER FAN ASSEMBLY
- 15 — HVIB AND SPD CONTROL PANEL
- 16 — FUSES
- 17 — CAPACITOR ASSEMBLY
- 18 — ADIB PANEL ASSEMBLY
- 19 — POWER BOX ASSEMBLY (TOP HAT)

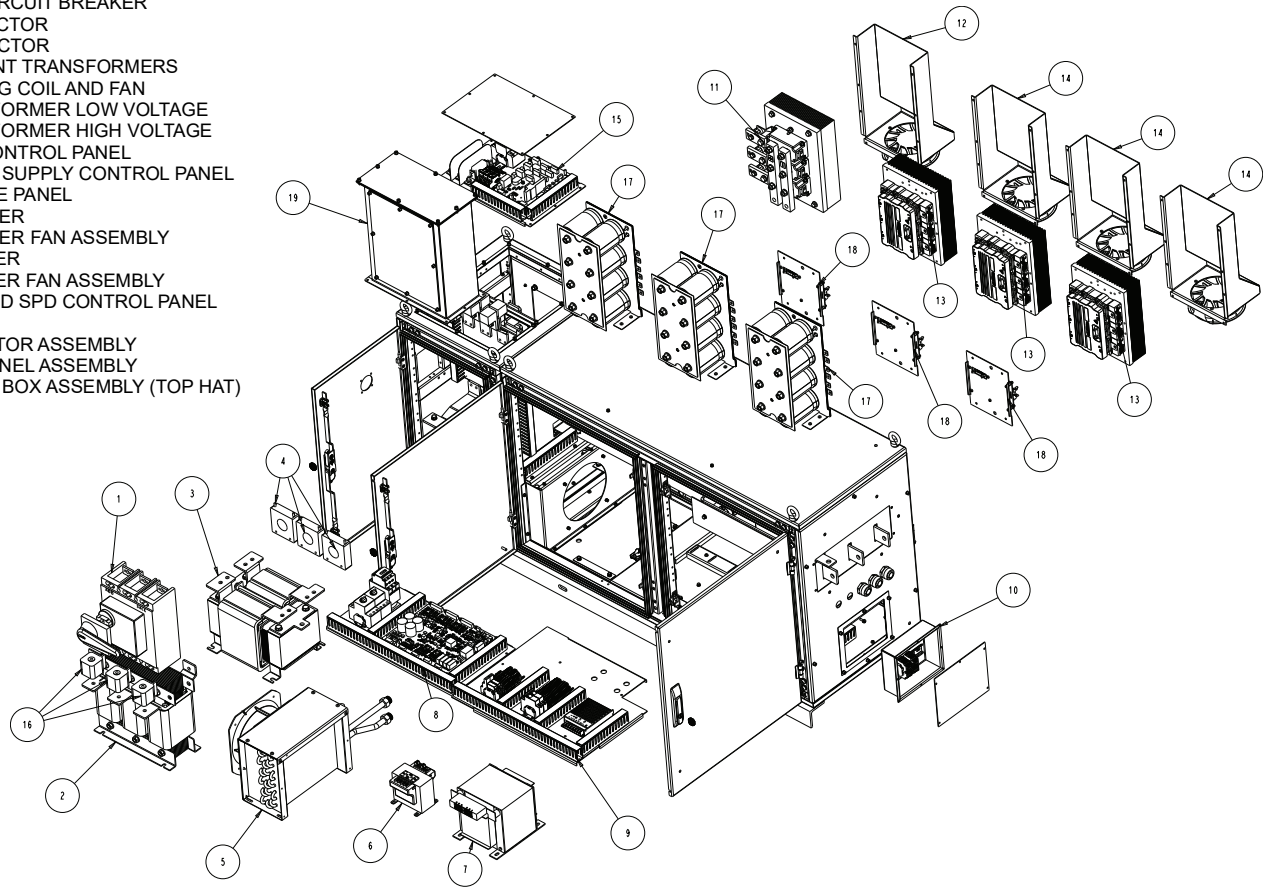

Fig. 57 — Exploded View of 32VS VFD, 680 Amp

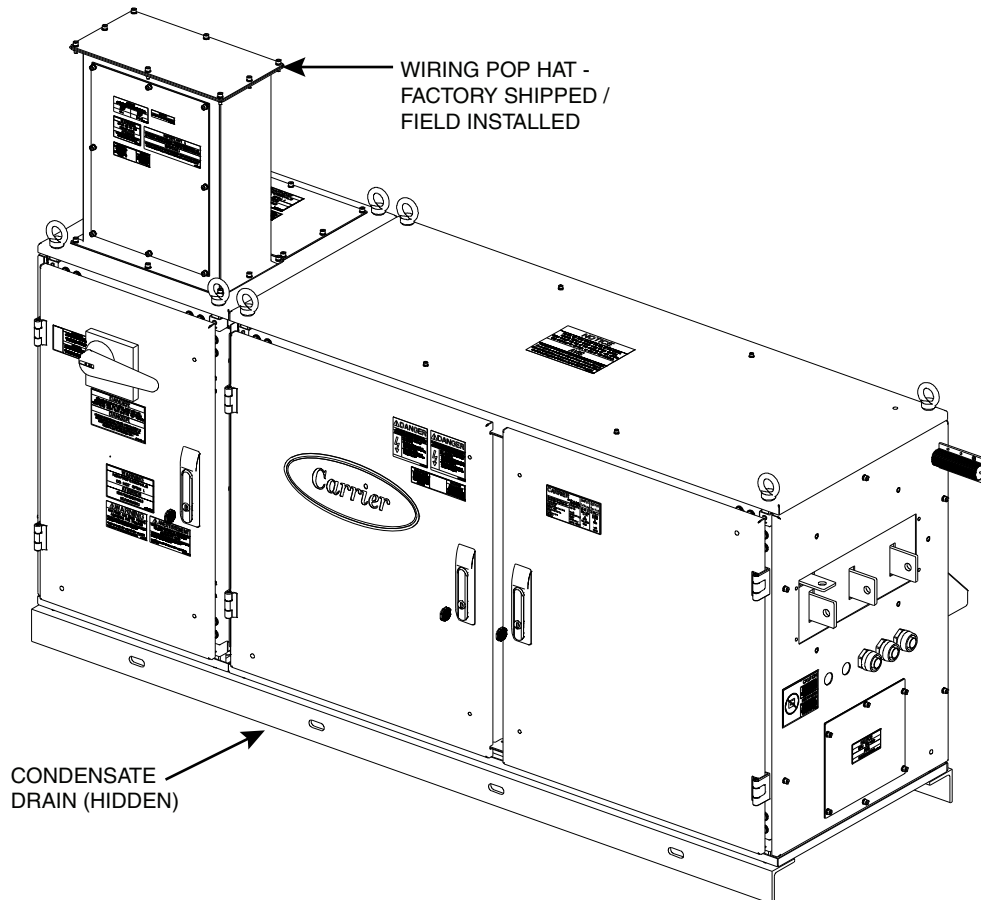
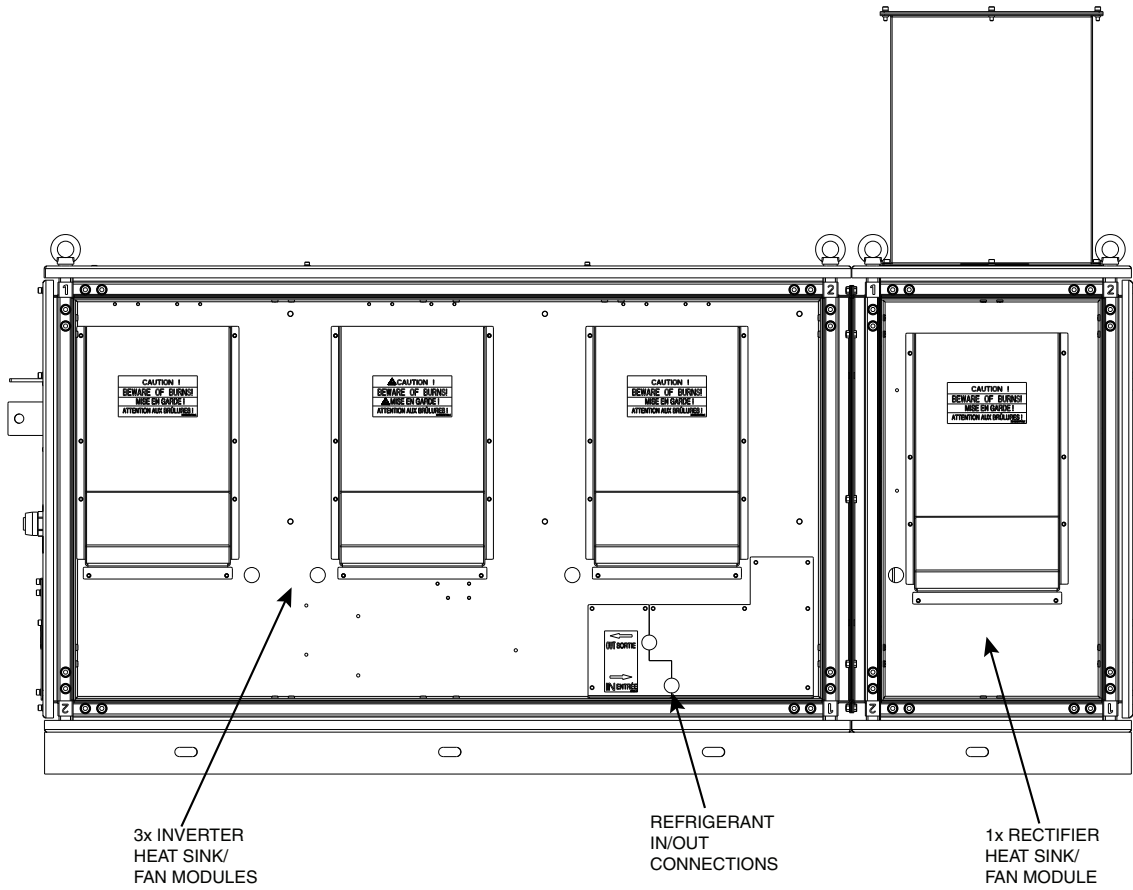

Fig. 58 — 680 Amp VFD Assembly Showing Electrical Pull Box



**Fig. 59 — 680 Amp VFD Assembly Back View
Showing Condensate Drain and Heat Sinks/Cooling Fans**

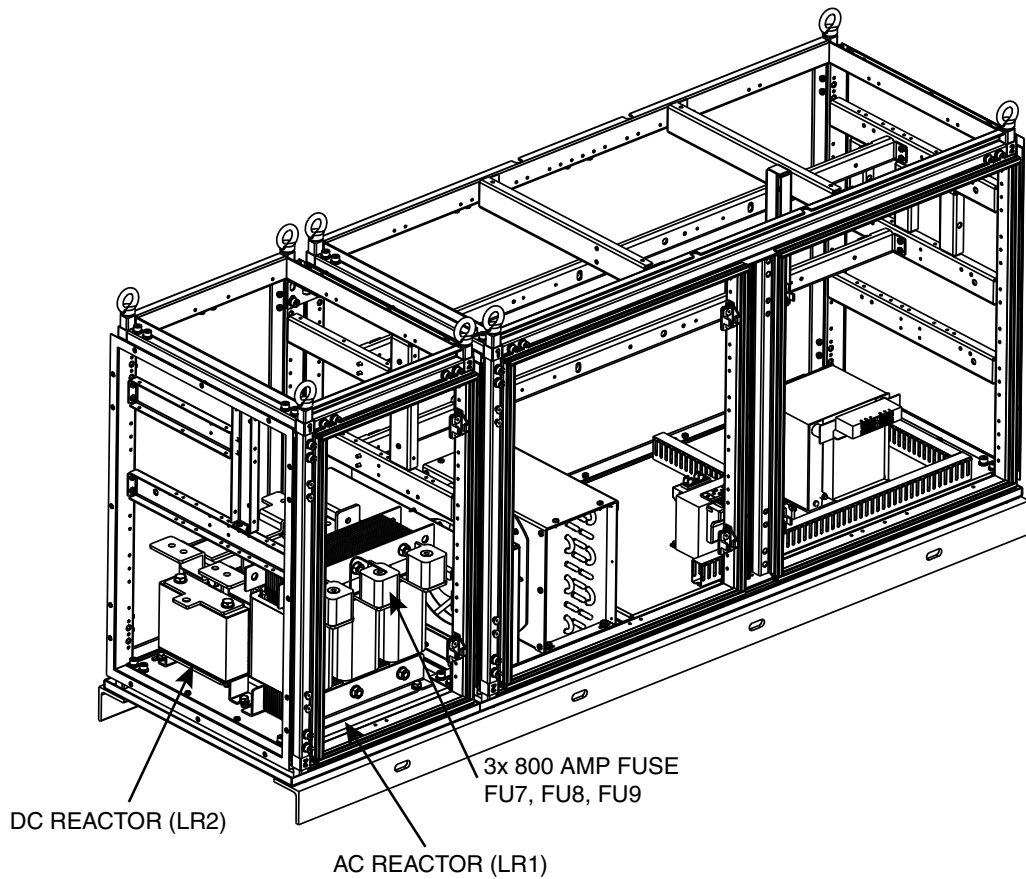

Fig. 60 — 680 Amp VFD Assembly Detail Showing Reactor and Main Line Fuse Locations

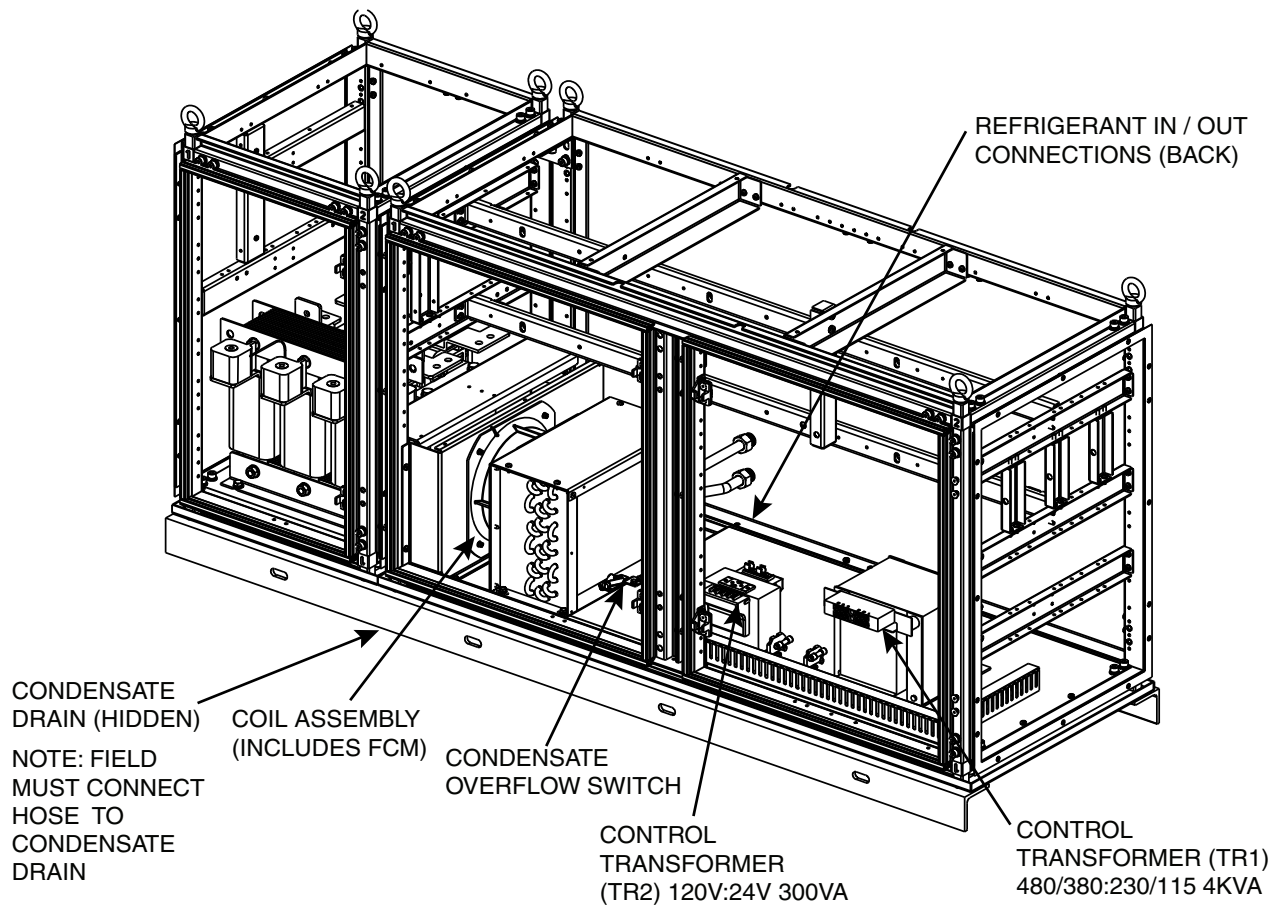

Fig. 61 — 680 Amp VFD Assembly — Condensate Switch and Drain

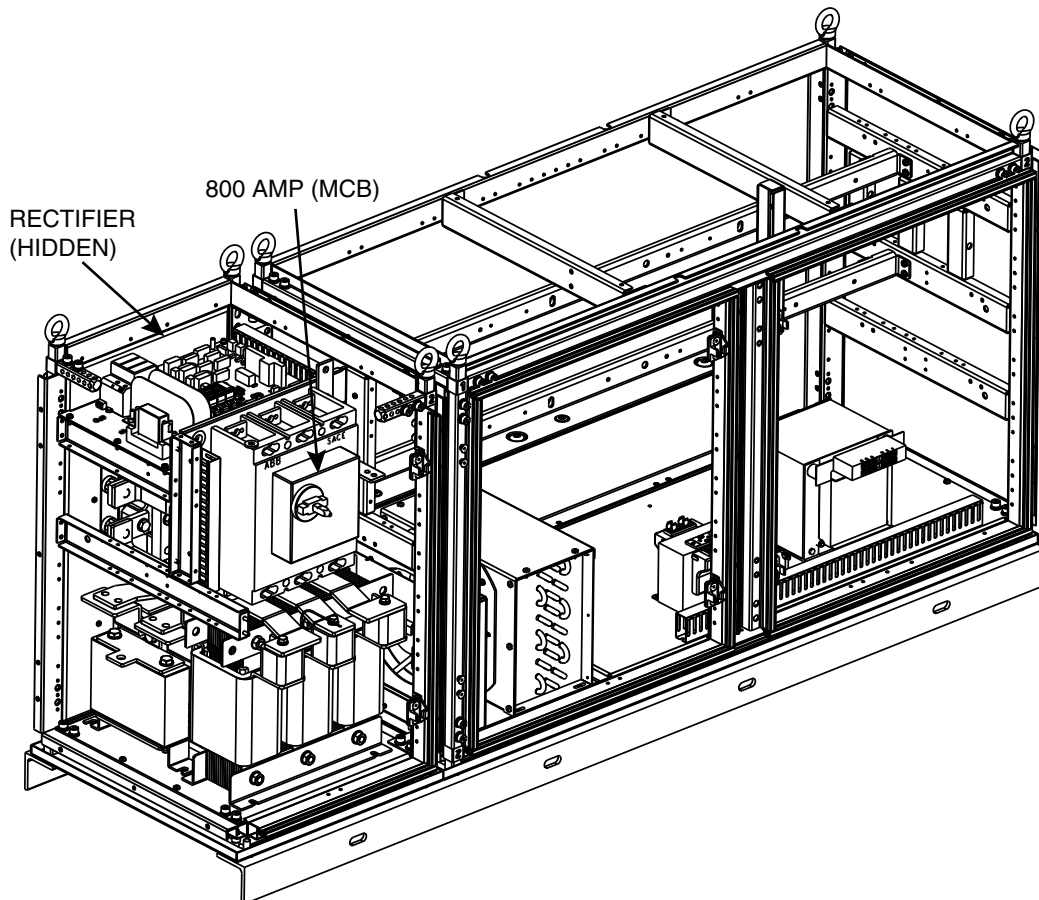

Fig. 62 — 680 Amp VFD Assembly Detail Showing Rectifier and Main Circuit Breaker (MCB) Locations

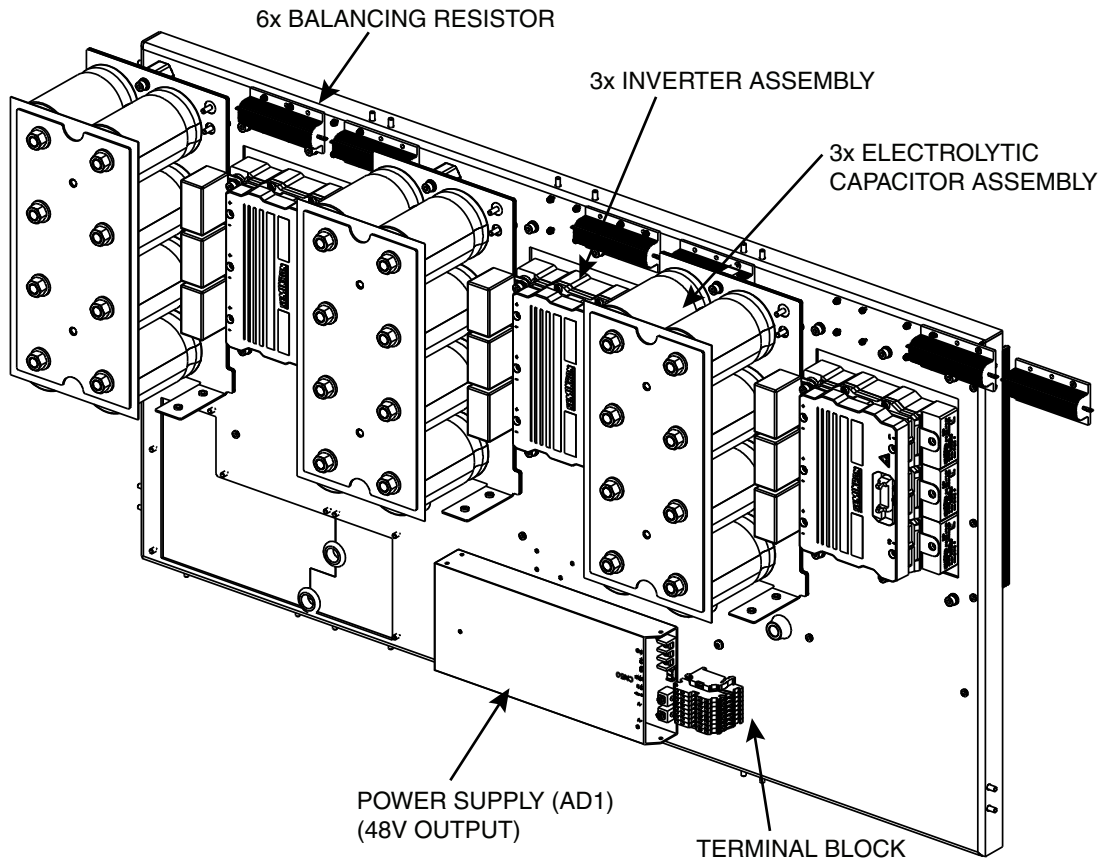
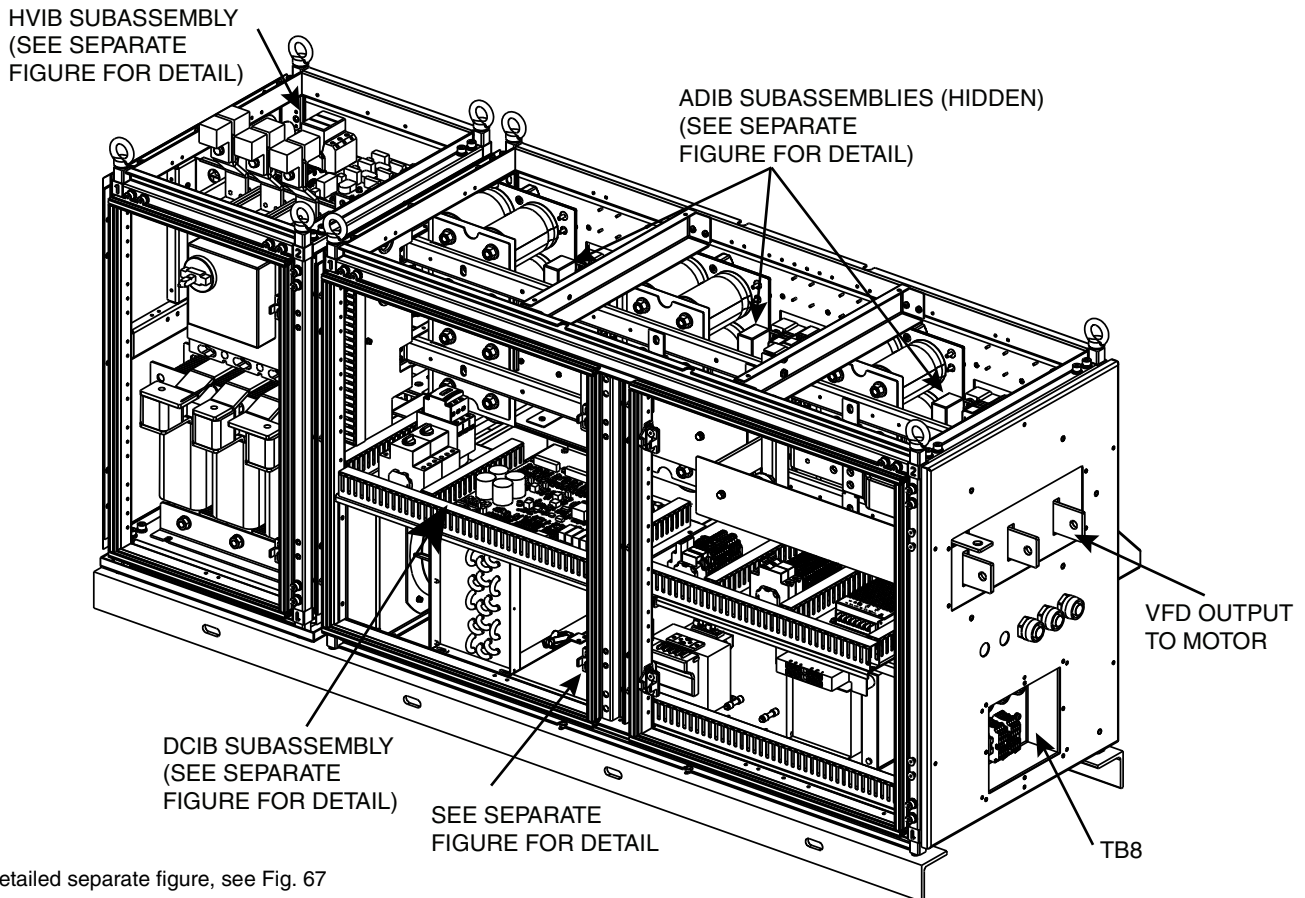
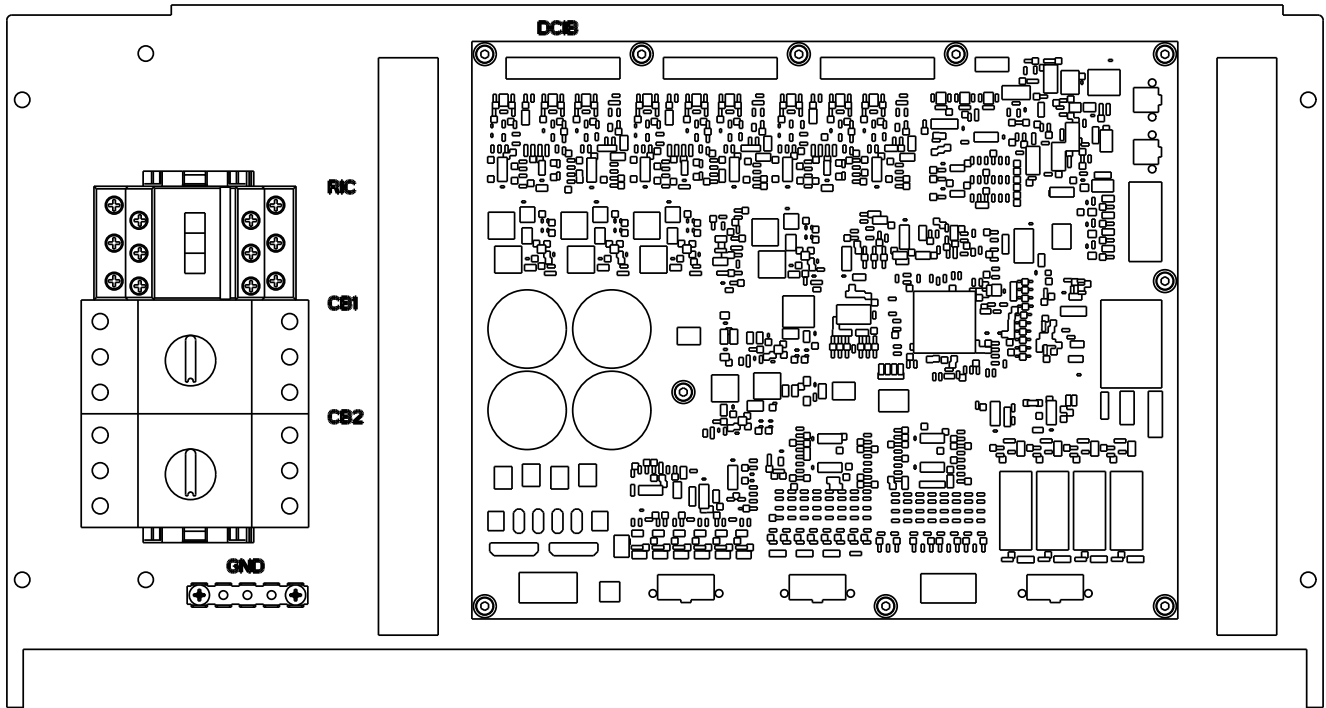

Fig. 63 — 680 Amp VFD Assembly Detail Showing Inverter and Capacitor Bank Assemblies



For detailed separate figure, see Fig. 67

Fig. 64 — 680 Amp VFD Assembly Detail Showing DCIB, HVIB, and ADIB Locations



LEGEND

- CB1** — Circuit Breaker 1
- CB2** — Circuit Breaker 2
- DCIB** — Drive Control Interface Board
- GDCIBND** — Ground
- RIC** — Run Interlock Contactor

Fig. 65 — 680 Amp VFD, DCIB Subassembly

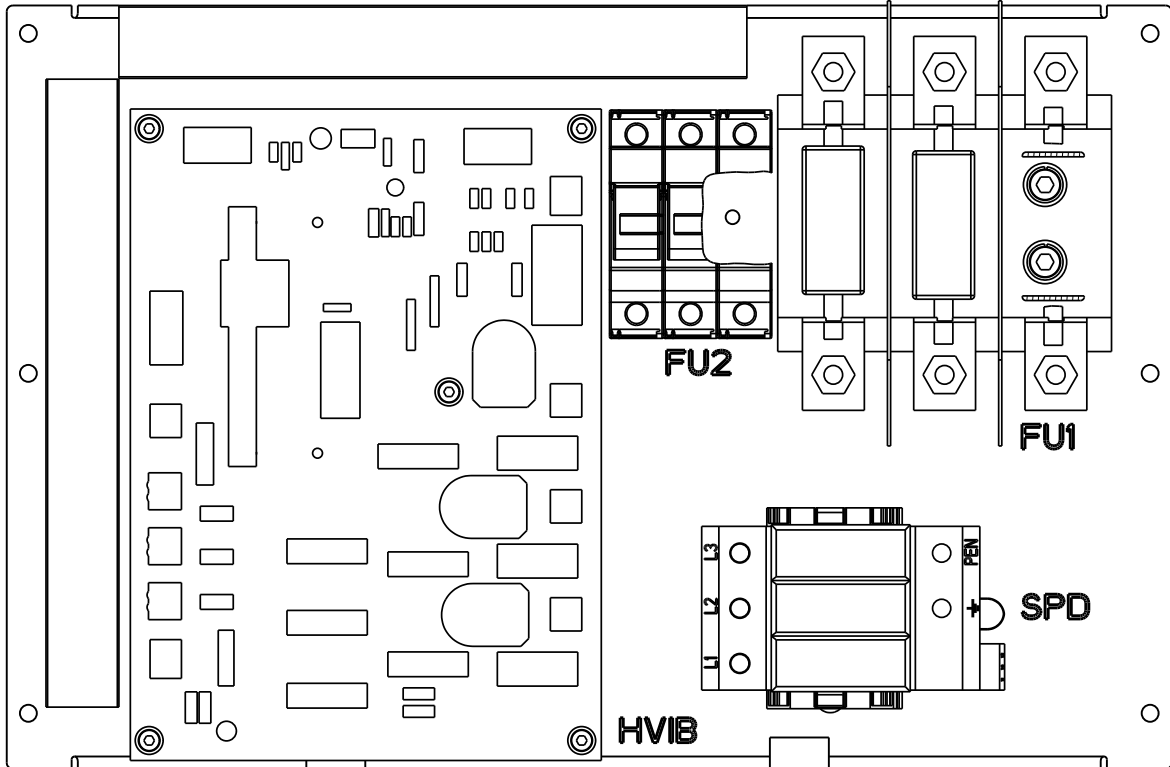

LEGEND

- FU1** — Fuse 1
- FU2** — Fuse 2
- HVIB** — High Voltage Interface Board
- SPD** — Surge Protection Device

Fig. 66 — Detail of HVIB Subassembly for 680 Amp VFD

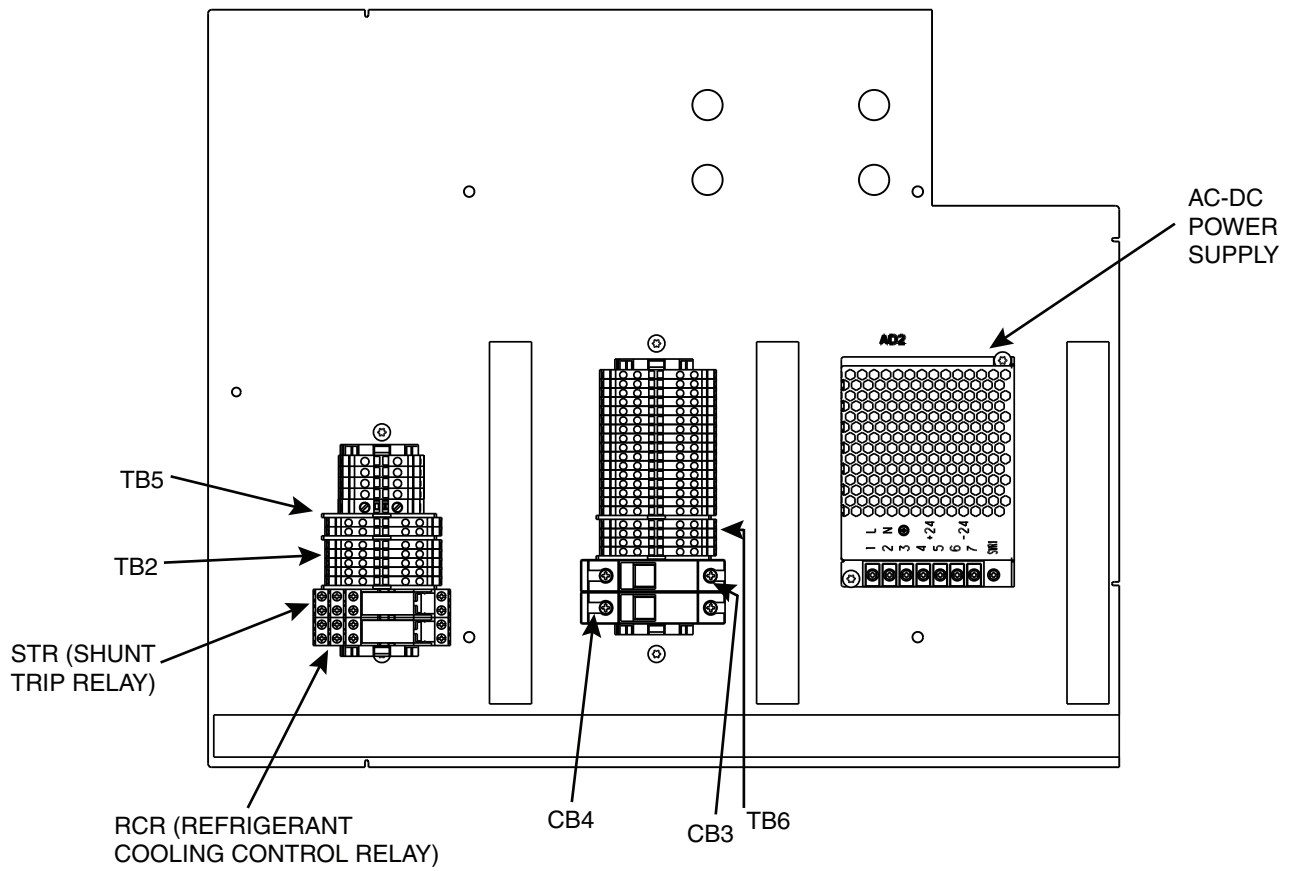

Fig. 67 — 680 Amp VFD Assembly Detail

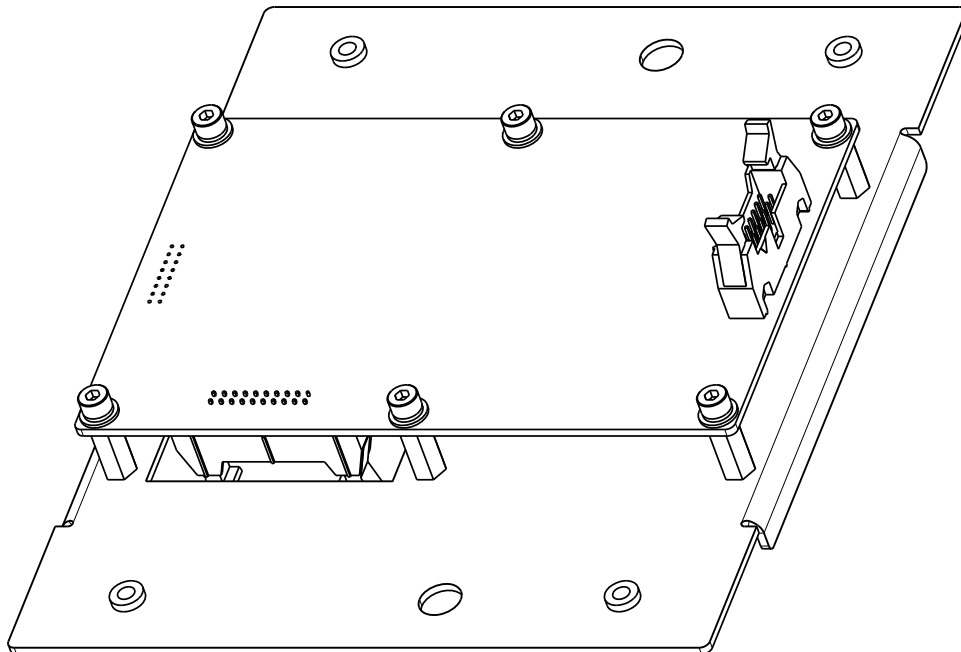
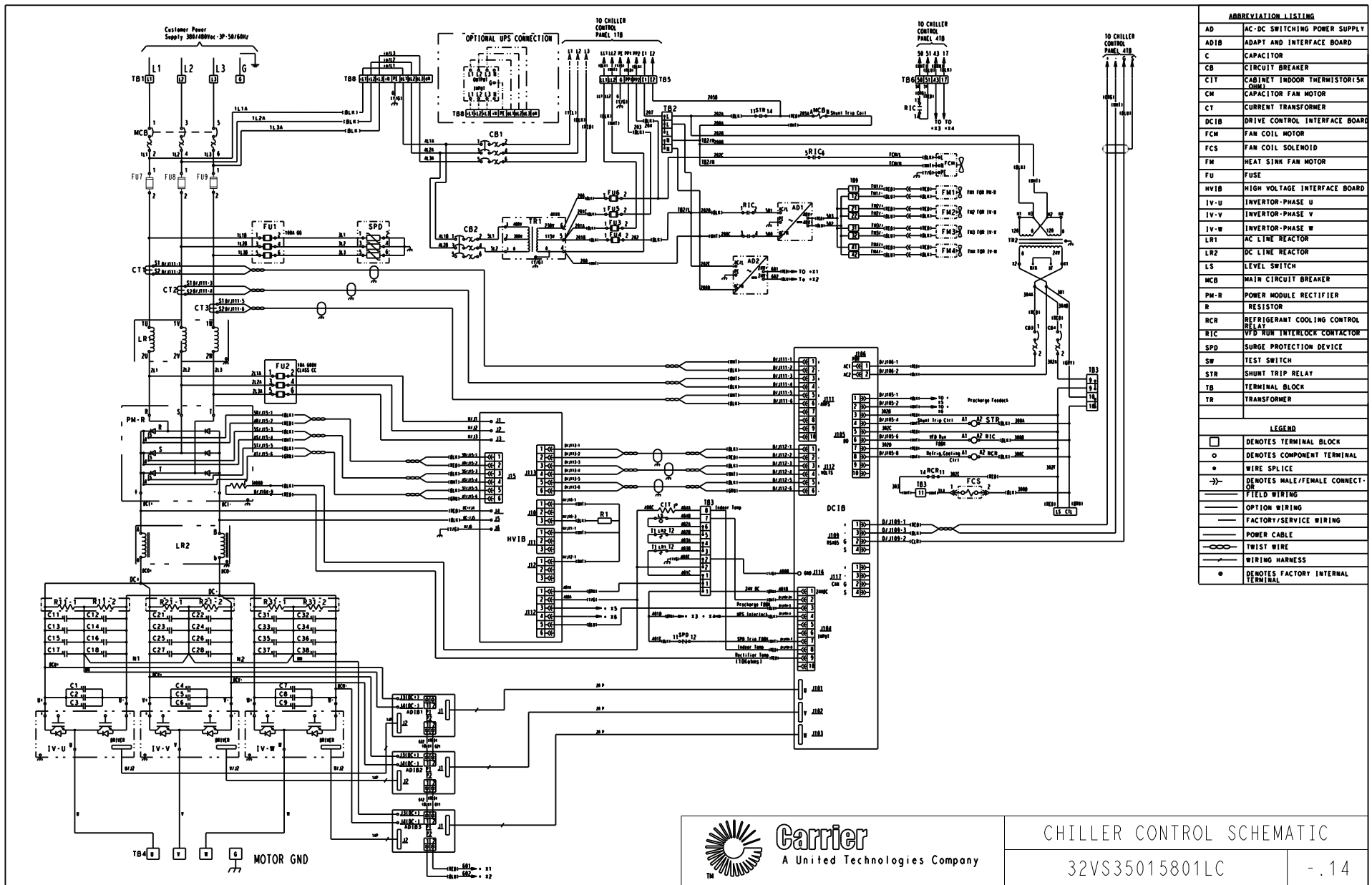

Fig. 68 — Detail of ADIB Subassembly for 680 Amp VFD



ABBREVIATION LISTING	
AD	AC-DC SWITCHING POWER SUPPLY
ADIB	ADAPT AND INTERFACE BOARD
C	CAPACITOR
CB	CIRCUIT BREAKER
CT	CABINET INDOOR THERMISTOR (SK OWN)
CM	CAPACITOR FAN MOTOR
CT	CURRENT TRANSFORMER
DCIB	DRIVE CONTROL INTERFACE BOARD
FCM	FAN COIL MOTOR
FCS	FAN COIL SOLENOID
FM	HEAT SINK FAN MOTOR
FU	FUSE
HVIB	HIGH VOLTAGE INTERFACE BOARD
IV-U	INVERTOR-PHASE U
IV-V	INVERTOR-PHASE V
IV-W	INVERTOR-PHASE W
LR1	AC LINE REACTOR
LR2	DC LINE REACTOR
LS	LEVEL SWITCH
MCB	MAIN CIRCUIT BREAKER
PM-R	POWER MODULE RECTIFIER
R	RESISTOR
RCR	REFRIGERANT COOLING CONTROL RELAY
RIC	VFD RUN INTERLOCK CONTACTOR
SPD	SURGE PROTECTION DEVICE
SW	TEST SWITCH
STR	SHUNT TRIP RELAY
TB	TERMINAL BLOCK
TR	TRANSFORMER
LEGEND	
□	DENOTES TERMINAL BLOCK
○	DENOTES COMPONENT TERMINAL
⊙	WIRE SPLICE
→	DENOTES MALE/FEMALE CONNECTOR
—	FIELD WIRING
—	OPTION WIRING
—	FACTORY/SERVICE WIRING
—	POWER CABLE
—	TWIST WIRE
—	WIRING HARNESS
●	DENOTES FACTORY INTERNAL TERMINAL



CHILLER CONTROL SCHEMATIC

32VS35015801LC

. 14

Fig. 69 — 680 Amp VFD Chiller Control Schematic

77

- 1 — FLEX BAR
- 2 — DCIB
- 3 — COIL ASSEMBLY
- 4 — TRANSFORMER 4 kVA
- 5 — DC REACTOR
- 6 — CURRENT TRANSFORMERS
- 7 — RECTIFIER
- 8 — AC REACTOR
- 9 — RECTIFIER FAN ASSEMBLY
- 10 — INVERTER FAN ASSEMBLY
- 11 — INVERTER
- 12 — COIL ASSEMBLY
- 13 — DCIB/HVIB (BACK) CONTROL ASSEMBLY
- 14 — TRANSFORMER 4 kVA
- 15 — DC REACTOR
- 16 — CONTROL ASSEMBLY
- 17 — CURRENT TRANSFORMERS
- 18 — SERVICE COMMUNICATION PANEL
- 19 — DC REACTOR

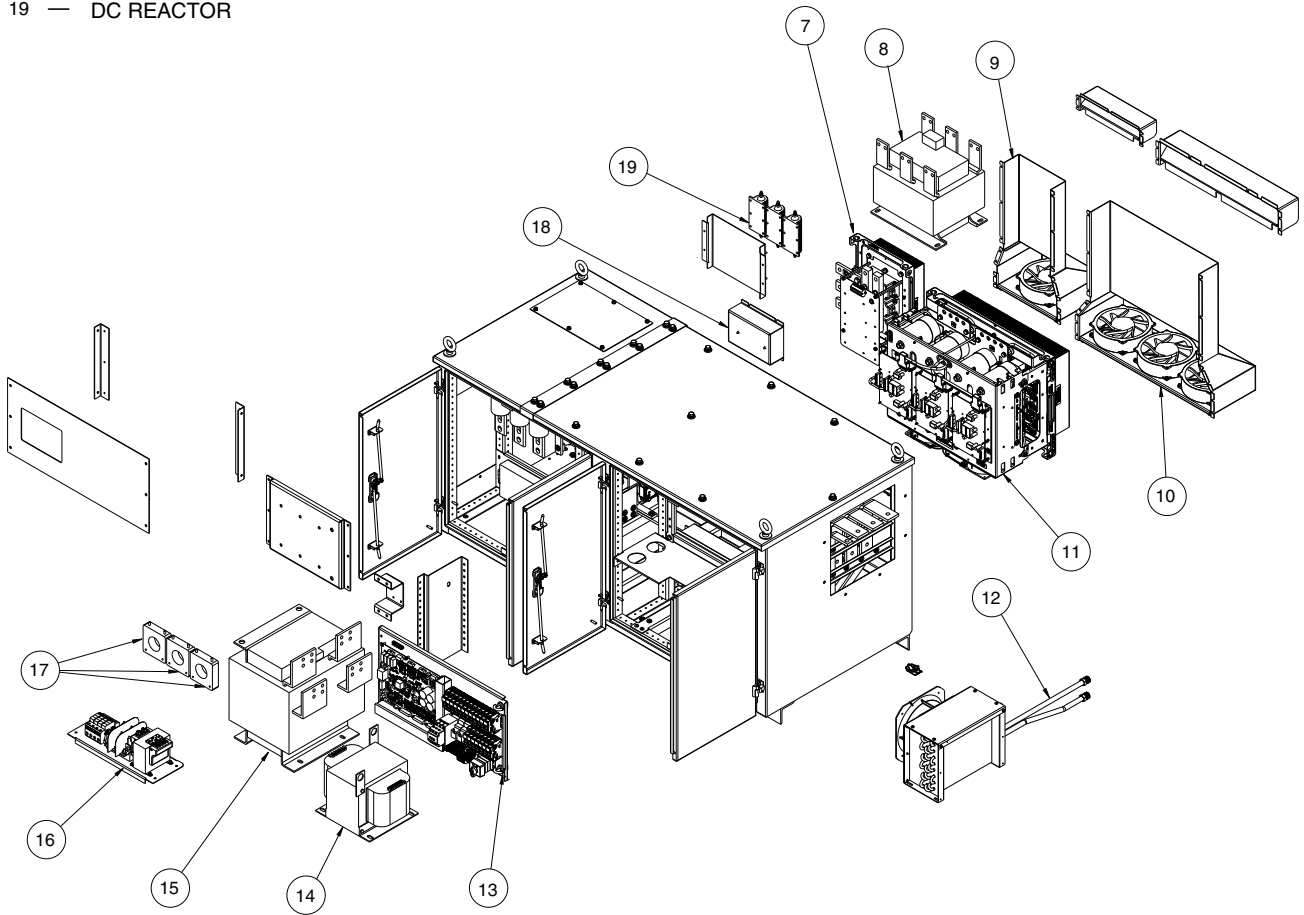
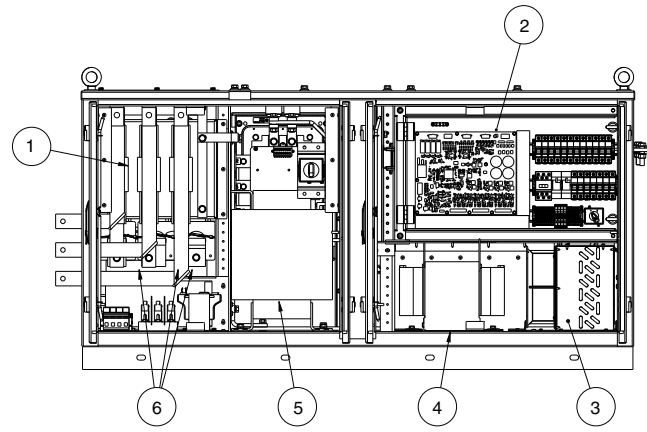

Fig. 70 — Exploded View of 32VS VFD, 850 Amp

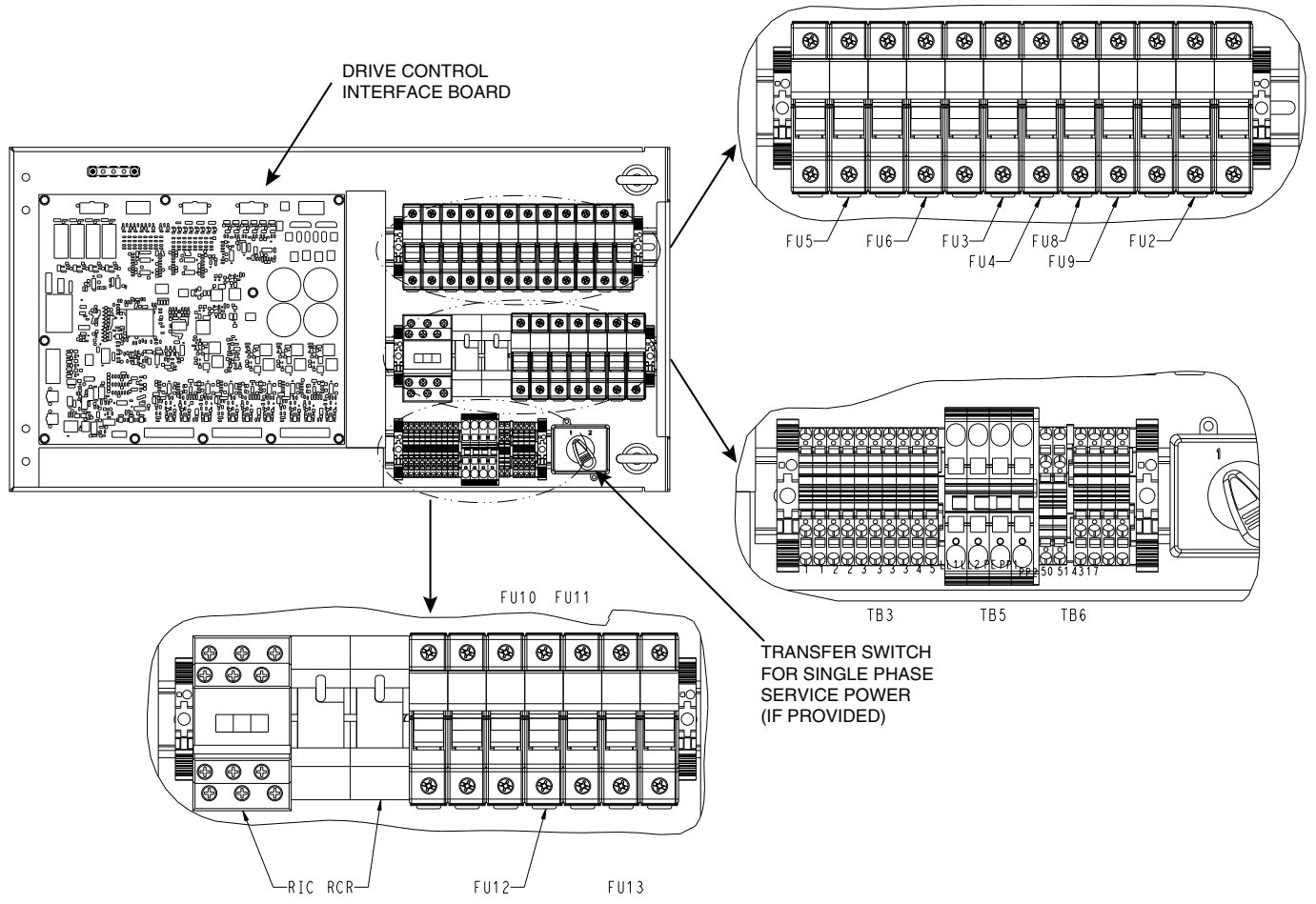
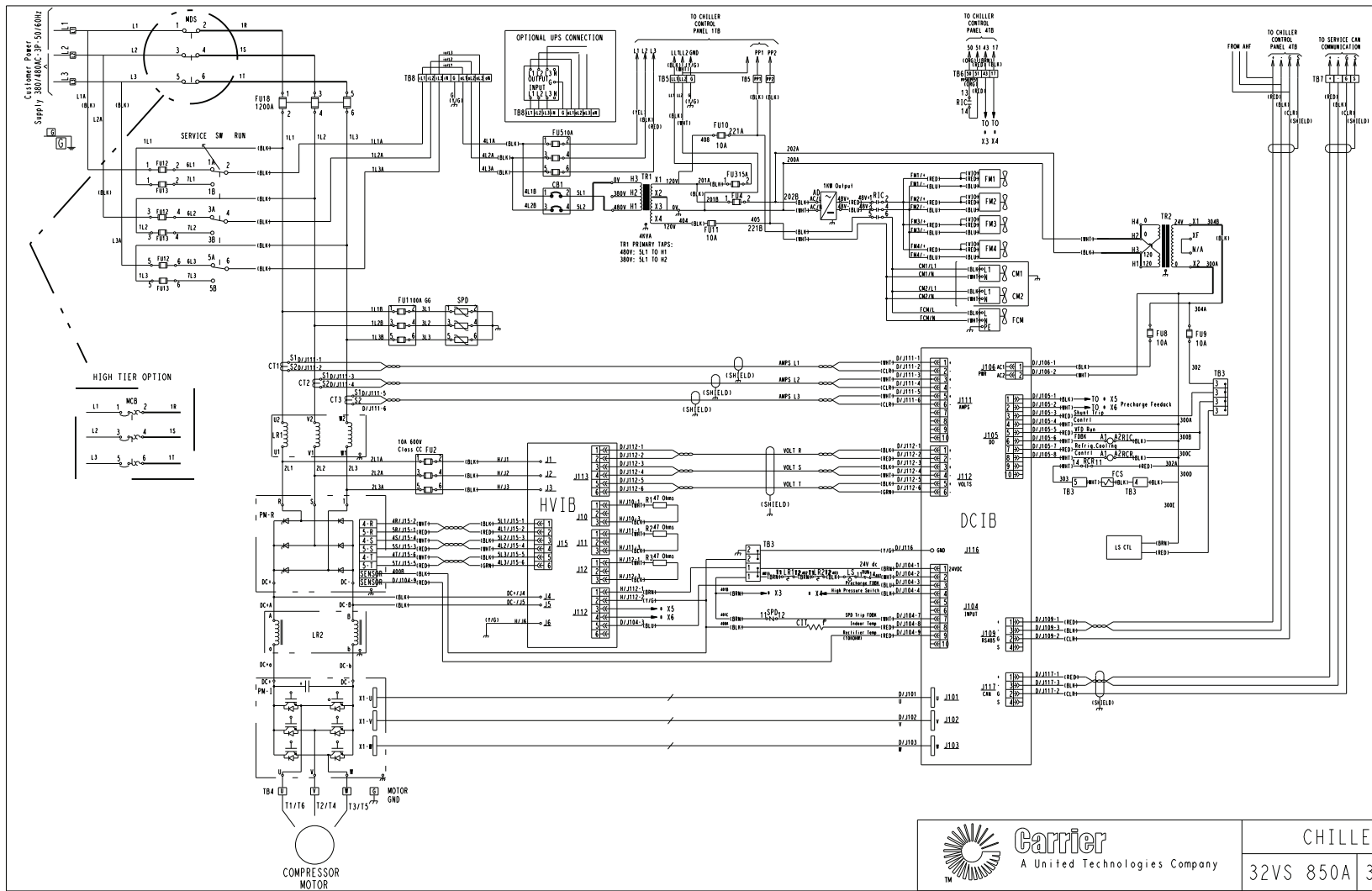

Fig. 71 — VFD Power Panel Assembly



ABBREVIATION LISTING	
AD	AC-DC SWITCHING POWER SUPPLY
AM	AMPS METER
C	CAPACITOR
CB	CIRCUIT BREAKER
CT1	CABINET INDOOR THERMISTOR(5K OHM)
CM	CAPACITOR FAN MOTOR
CT	CURRENT TRANSFORMER
DCIB	DRIVE CONTROL INTERFACE BOARD
FCM	FAN COIL MOTOR
FCS	FAN COIL SOLENOID
FM	HEAT SINK FAN MOTOR
FU	FUSE
HVIB	HIGH VOLTAGE INTERFACE BOARD
LR1	AC LINE REACTOR
LR2	DC LINE REACTOR
LS	LEVEL SWITCH
LSR	LEVEL SWITCH RELAY
RIC	RUN INTERLOCK CONTROL
PM-I	POWER MODULE INVERTER
PM-R	POWER MODULE RECTIFIER
R	PRECHARGE RESISTOR
RCD	REFRIGERANT COOLING CONTROL RELAY
SPD	SURGE PROTECTION DEVICE
SW	SERVICE SWITCH
TB	TERMINAL BLOCK
TR	TRANSFORMER
VM	VOLTAGE METER
LS CTL	LEVEL SWITCH CONTROLLER
MDS	MAIN DISCONNECT SWITCH

LEGEND	
	DENOTES TERMINAL BLOCK
	DENOTES COMPONENT TERMINAL
	WIRE SPLICE
	DENOTES MALE/FEMALE CONNECTOR
	FIELD WIRING
	OPTION WIRING
	FACTORY/SERVICE WIRING
	POWER CABLE
	TWIST WIRE
	WIRING HARNESS



Carrier
A United Technologies Company

CHILLER VFD SCHEMATIC

32VS 850A	32VS25031201LC	-
-----------	----------------	---

Fig. 72 — 32VS 850A VFD Control Schematic

Active Harmonic Filter Option

The 32VS active harmonic filter (AHF) is installed in parallel with the power input of the VFD. Customer power input to the drive is to the AHF which routes power to the connected standard tier drive section. The AHF measures the current signal at the inlet of the VFD and corrects the sine curve error and thereby reduces the total harmonic distortion. There are two independent 150 amp AHFs that operate in parallel, which brings the AHF total amp value to 300 amp. It is approximately 35% of the 850 amp standard tier drive.

Note that there is access to the bus voltage DC+, and DC- on the fan control boards (FCB "A" and "B"). Since 32VS AHF consists of two power modules, each must be checked. DC bus voltage should be approximately 1.41 x line voltage. The fan control boards (FCBs) have an LED which identifies that the DC bus voltage is below 50 VDC. See Table 29. See Fig. 73-77 for AHF components and diagrams.

⚠ WARNING

ELECTRICAL SHOCK HAZARD

Always assume that full voltage is present until power source is locked and tagged out and the DC bus has been verified with a volt meter to be fully dissipated.

NOTE: It will take approximately 5 minutes for the capacitor bank to dissipate.

**Table 29 — Static AHF Test
(with Multimeter Set for Diode Test and No Power)**

TEST	(+) MULTIMETER PROBE	(-) MULTIMETER PROBE	MULTIMETER READING
1	R, S or T (test all 3)	(+) Terminal on FCB	Approx. 0.34 VDC
2	(+) Terminal on FCB	R, S or T (test all 3)	OL
3	(-) Terminal on FCB	R, S or T (test all 3)	Approx. 0.34 VDC
4	R, S or T (test all 3)	(-) Terminal on FCB	OL

NOTE: R, S, T and associated FCB need to be tested for both A and B power modules.

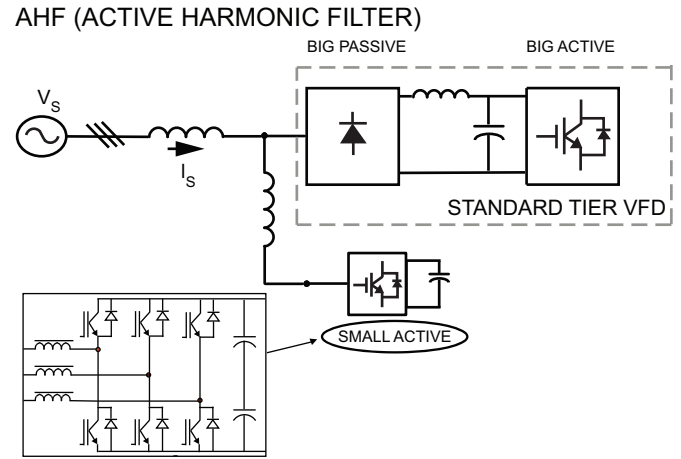

Fig. 73 — Active Harmonic Filter Topology

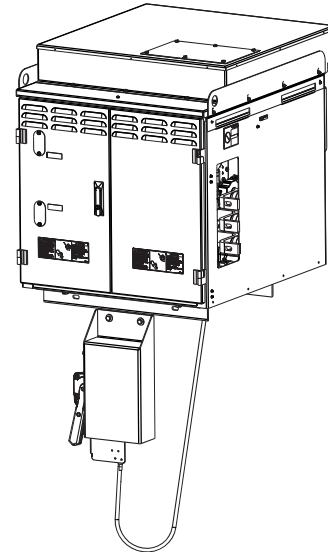

Fig. 74 — Active Harmonic Filter, 32 VS High Tier

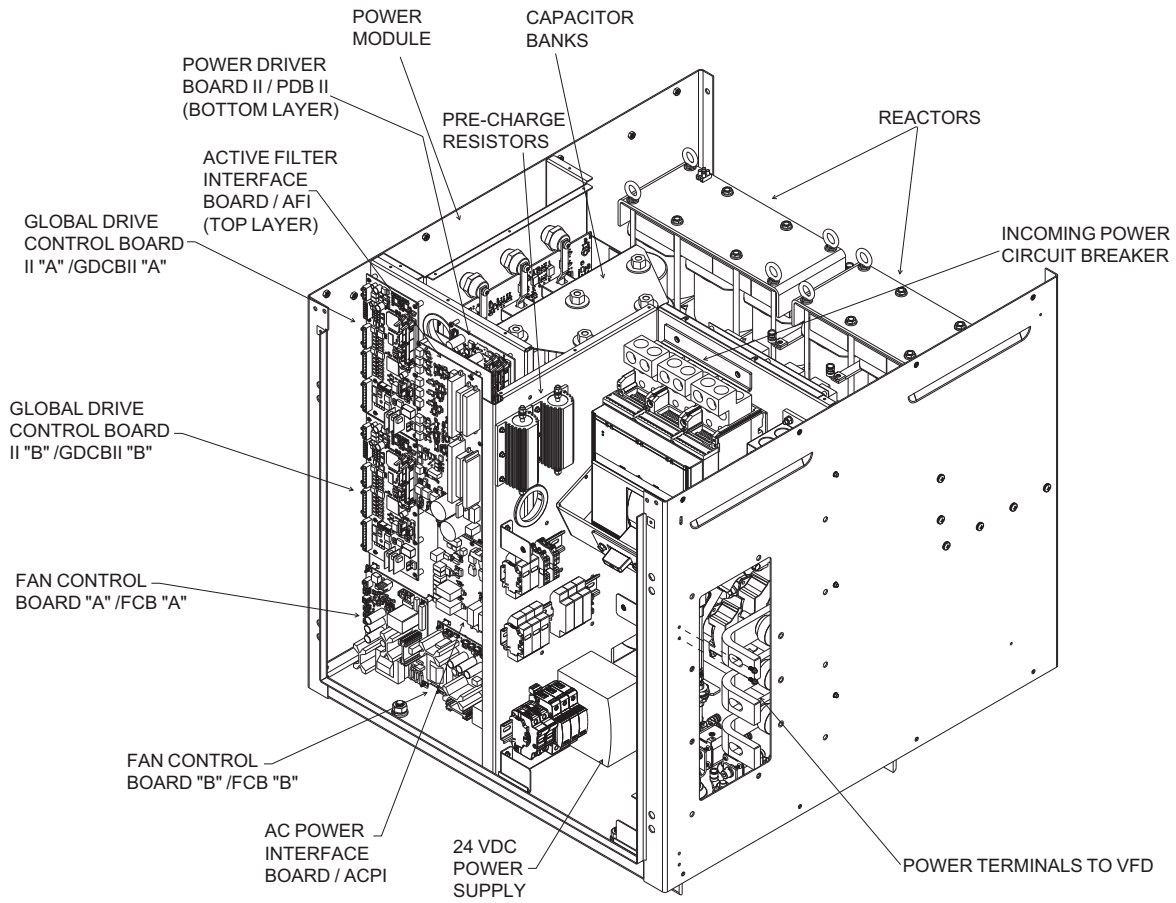

Fig. 75 — Active Harmonic Filter Components

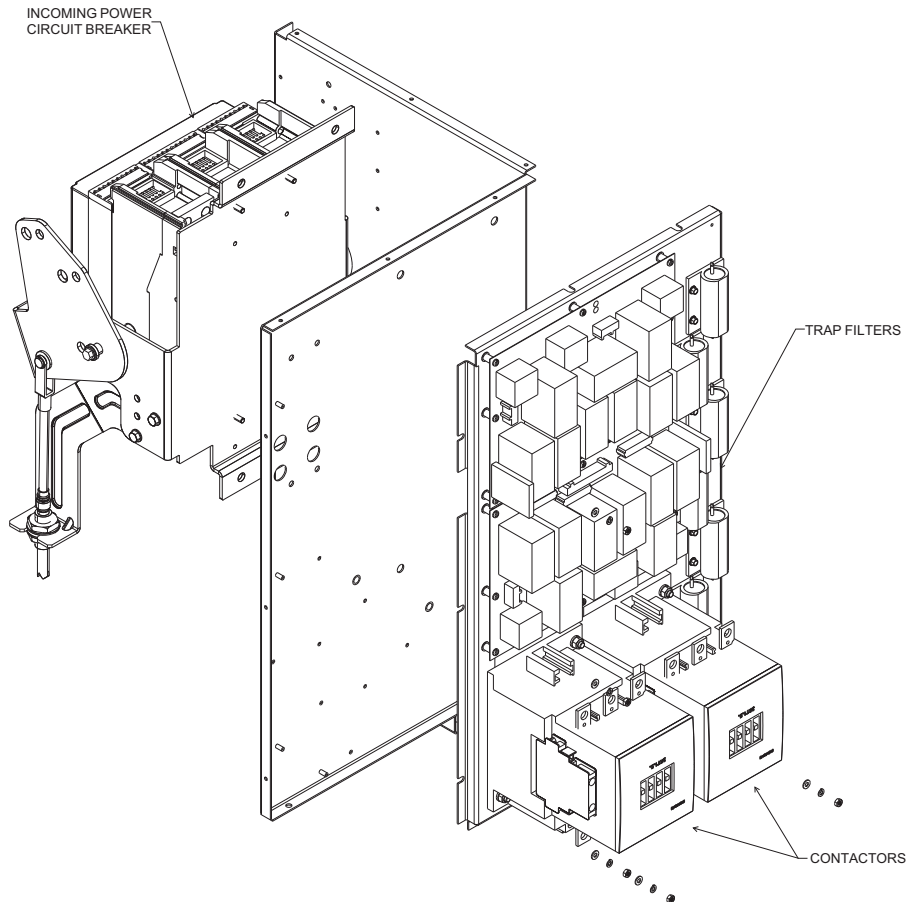

Fig. 76 — Active Harmonic Filter Power Components

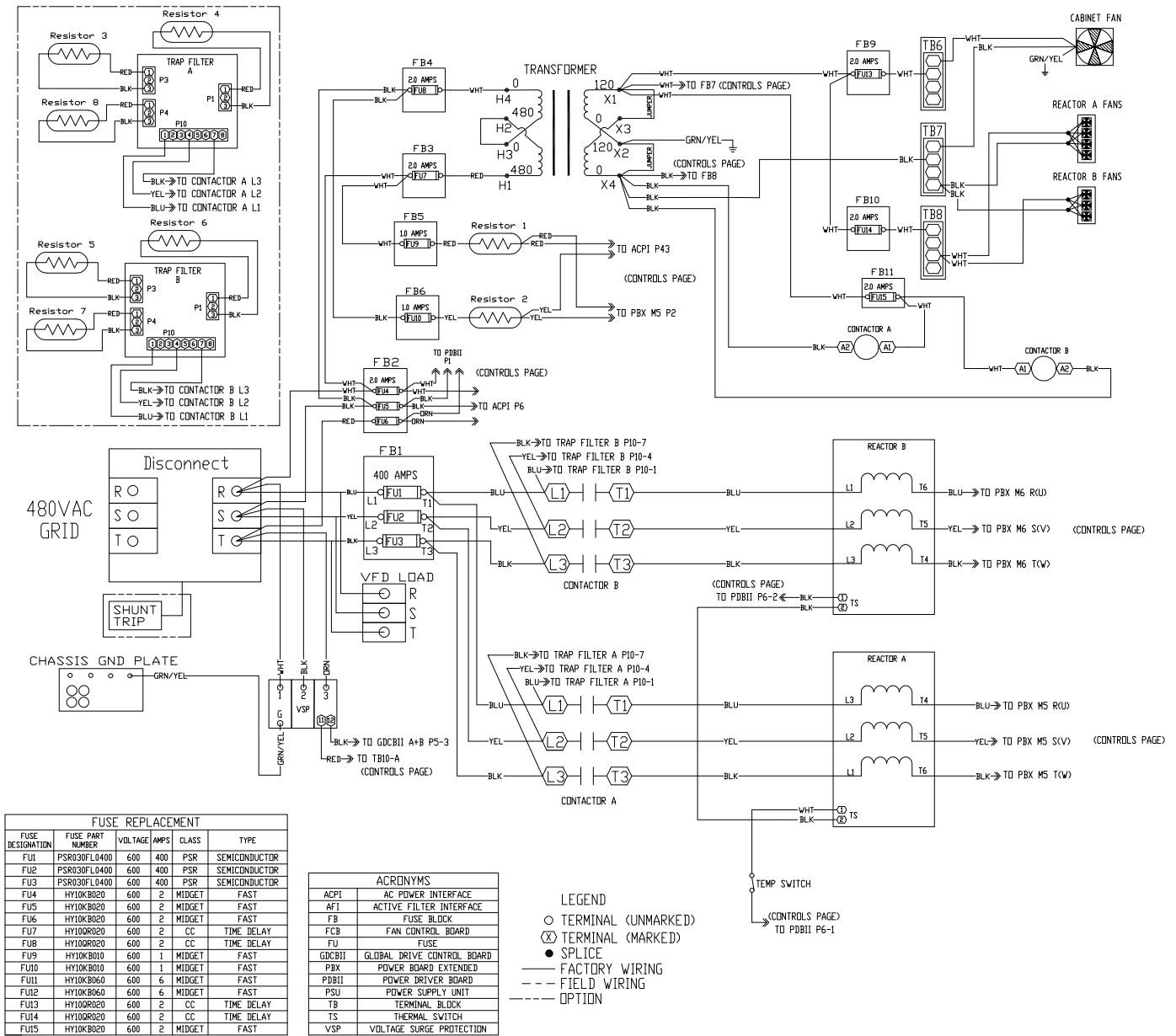

Fig. 77 — Active Harmonic Filter Power Schematic

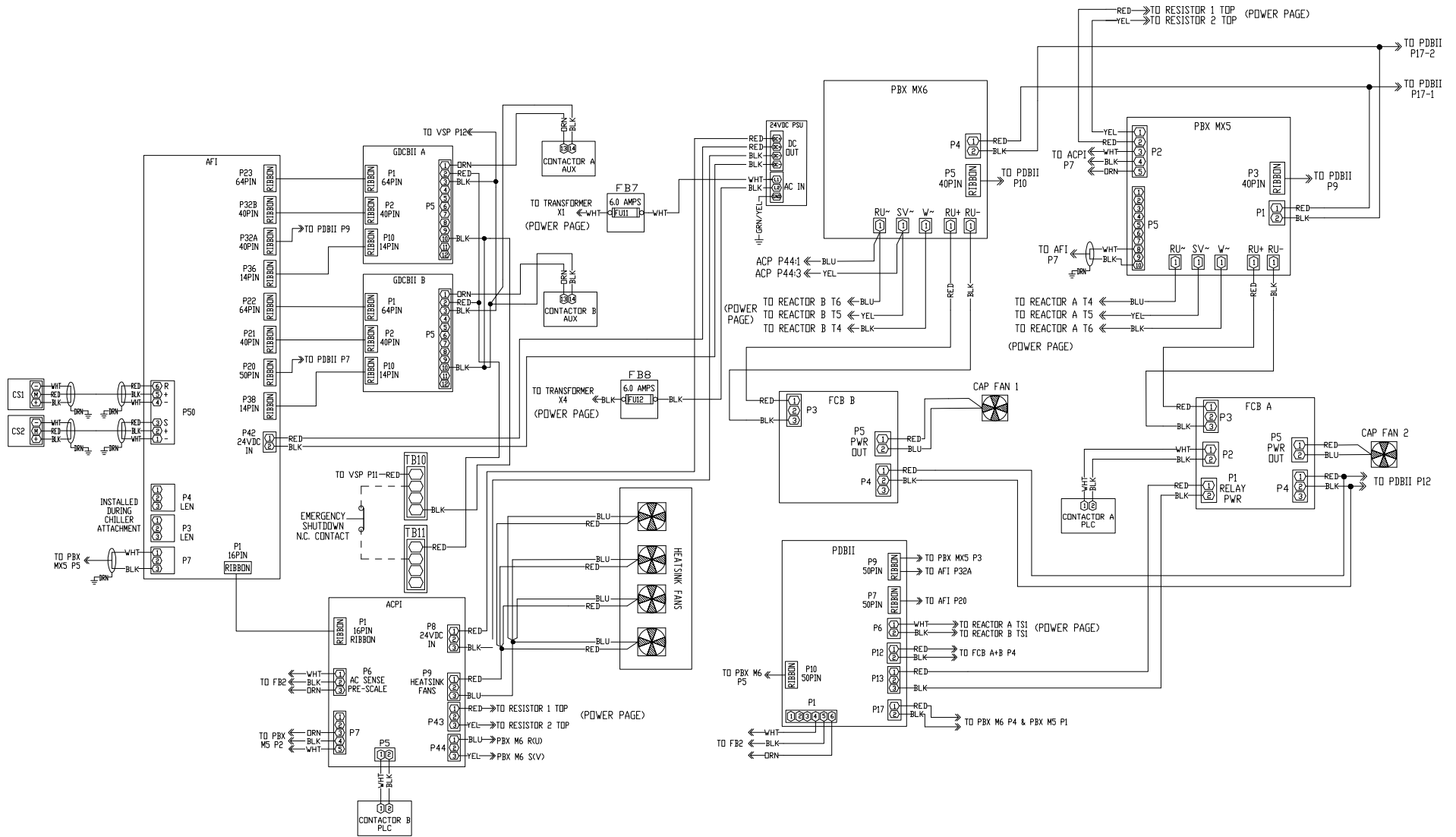

Fig. 77 — Active Harmonic Filter, 32 VS High Tier Controls (cont)

APPENDIX A — PIC6 SCREEN AND MENU STRUCTURE

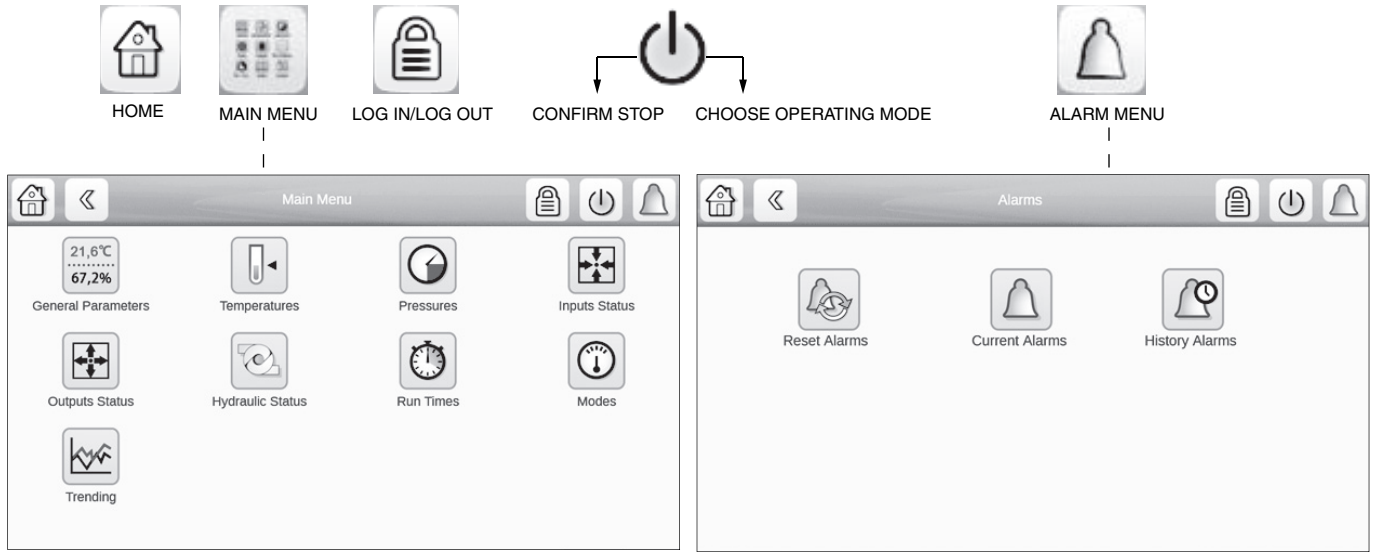

Fig. A — Screen Structure, Basic Level (All) Access (No Password Required)

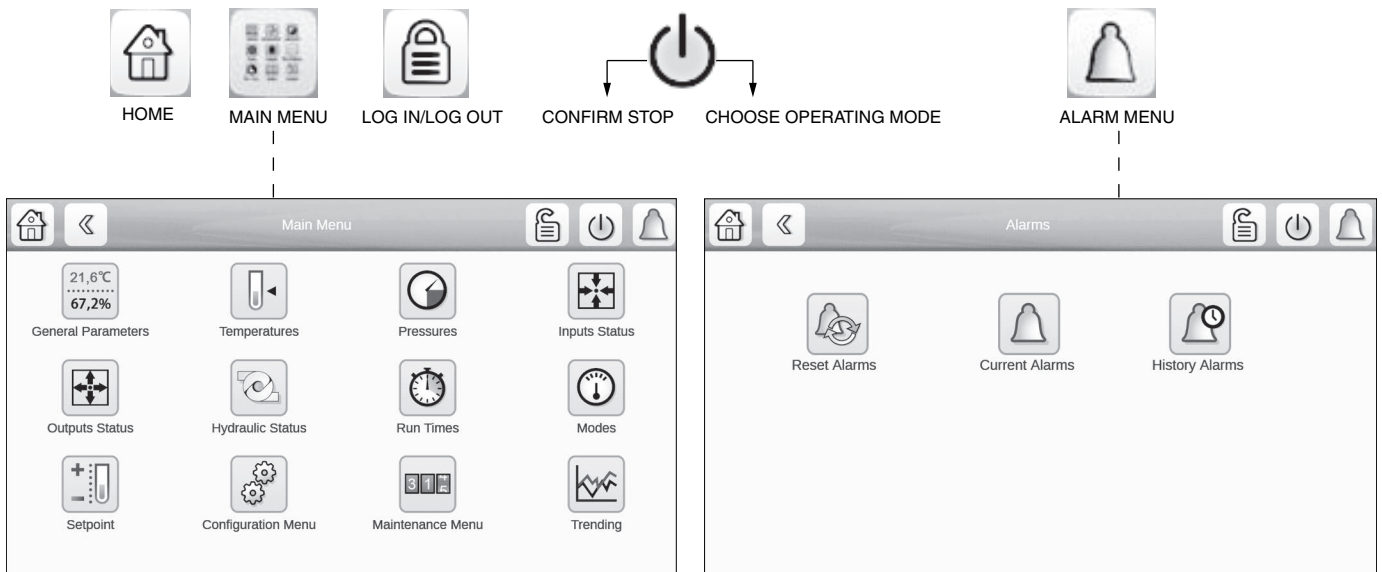

Fig. B — Screen Structure, User Level Access (User Password Required)

APPENDIX A — PIC6 SCREEN AND MENU STRUCTURE (CONT)

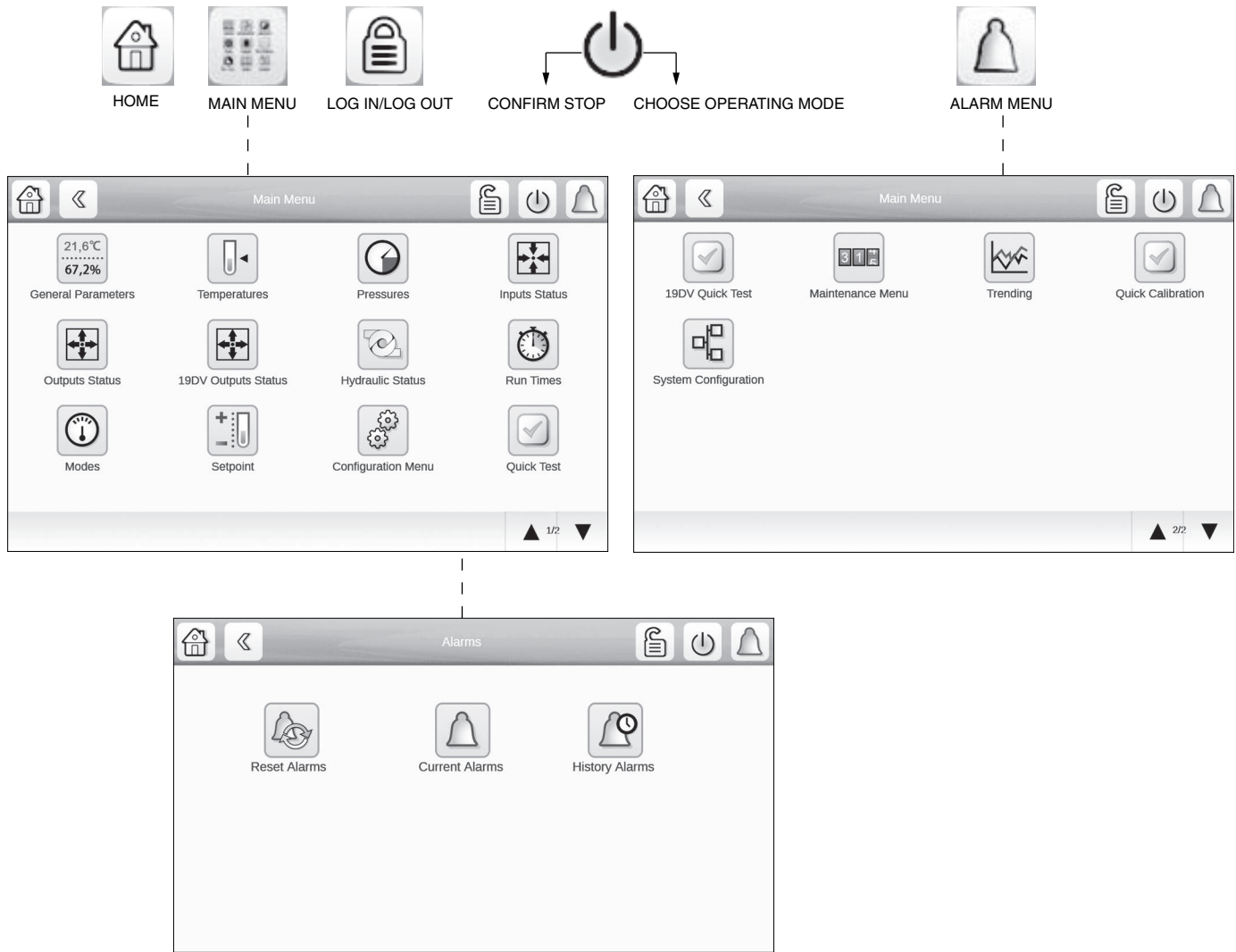















Fig. C — Screen Structure, Service (Advanced User) / Factory Level Access Password Required

APPENDIX A — PIC6 SCREEN AND MENU STRUCTURE (CONT)
MAIN MENU DESCRIPTION

ICON	DISPLAYED TEXT*	ACCESS	ASSOCIATED TABLE†
	General Parameters	Basic, User, Factory	GENUINT
	Temperatures	Basic, User, Factory	TEMP
	Pressures	Basic, User, Factory	PRESSURE
	Inputs Status	Basic, User, Factory	INPUTS
	Outputs Status	Basic, User, Factory	OUTPUTS
	19DV Outputs Status	Factory	OUTPUTS
	Hydraulic Status	Basic, User, Factory	HYDRLIC
	Run Times	Basic, User, Factory	RUNTIME
	Modes	Basic, User, Factory	MODES
	Set point	User, Factory	SETPOINT
	Configuration Menu	User, Factory	CONFIG
	Quick Test	Factory	QCK_TEST
	19DV Quick Test	Factory	DV_OUT
	Maintenance Menu	User, Factory	MAINTAIN
	Trending	Basic, User, Factory	TRENDING
	Quick Calibration	Factory	QCK_CALI
	System Configuration	Factory	System Configuration

* Displayed text depends on the selected language (default is English).
† See the 19DV with PIC6 Controls Operation and Troubleshooting manual for table details.

APPENDIX B — CCN COMMUNICATION WIRING FOR MULTIPLE CHILLERS (TYPICAL)

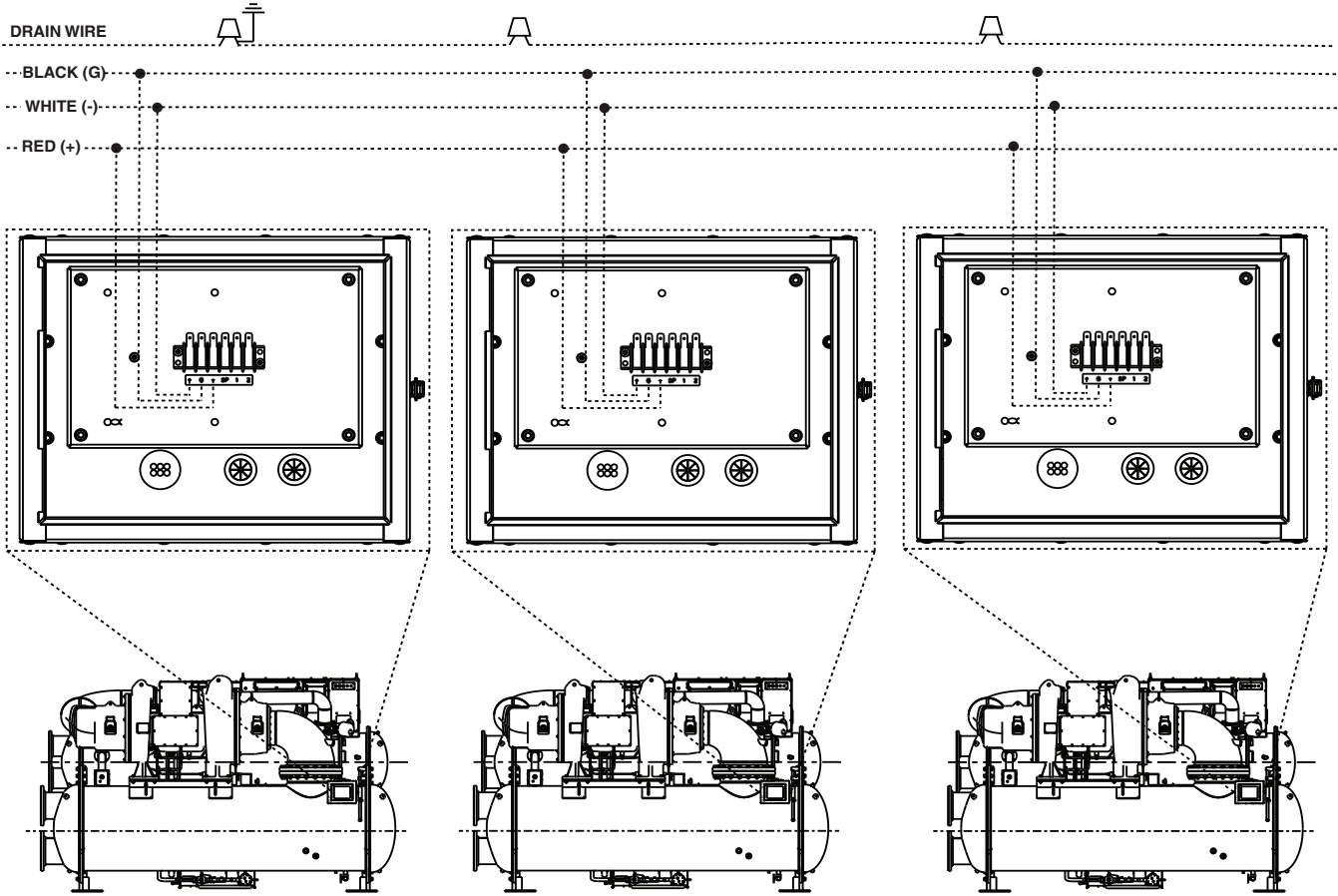

NOTE : Field-supplied terminal strip must be located in control panel.

**APPENDIX C — MAINTENANCE SUMMARY
AND LOG SHEETS
19DV MAINTENANCE INTERVAL REQUIREMENTS**

WEEKLY			
COMPRESSOR	None	CONTROLS	Review PIC6 Alarm/Alert History.
EVAPORATOR	None.	VFD	None.
CONDENSER	None.	INHIBITOR RECLAIM	None.
MONTHLY			
COMPRESSOR	None.	CONTROLS	Review and record purge operating time.
ANNUALLY			
COMPRESSOR	Change lubrication assembly refrigerant and bearing filters. Leak test. Vibration trending.	CONTROLS	Perform general cleaning. Tighten connections. Check pressure transducers. Confirm accuracy of thermistors.
EVAPORATOR	Inspect and clean evaporator tubes. Confirm there is no foreign debris in the tubes or waterboxes from the water system. Inspect all pressure relief devices. Leak test. Verify water pressure differential. Inspect water pumps. Send refrigerant sample out for analysis. Replace liquid strainer in inhibitor reclaim line (closes to evaporator inlet).	VFD	Perform general cleaning. Tighten connections. Change refrigerant/motor filter feeding VFD devices. Perform visual inspection of the capacitors located on the DC bus and inductors. Check cooling fan operation. Check condensate drain for the VFD enclosure. Change VFD strainer.
CONDENSER	Inspect and clean condenser tubes. Leak test. Verify water pressure differential. Inspect water pumps and cooling tower.	PURGE	Record total purge Pumpout Numbers and Pumpout Time. If excessive then leak test and correct. Inspect moisture sight glasses in line to bearings and VFD. Replace purge strainer in drain line.
LUBRICATION ASSEMBLY	Replace both refrigerant filter and bearing filter.		
EVERY 3 TO 5 YEARS			
COMPRESSOR	None.	CONTROLS	None.
EVAPORATOR	Perform eddy current test.	VFD	None.
CONDENSER	Inspect float valves and strainers. Perform eddy current test.	PURGE	None.
EVERY 5 YEARS			
COMPRESSOR	Replace gas strainer prior to eductor (or when refrigerant is removed).	CONTROLS	None.
EVAPORATOR	None.	VFD	None.
CONDENSER	None.	PURGE	
LUBRICATION ASSEMBLY	Replace lubrication assembly suction strainers (or when refrigerant is removed).		
SEASONAL SHUTDOWN			
COMPRESSOR	None.	CONTROLS	Do not disconnect control power.
EVAPORATOR	Isolate and drain waterbox. Remove waterbox cover from one end. Use compressed air to clear tubes.	VFD	None.
CONDENSER	Isolate and drain waterbox. Remove waterbox cover from one end. Use compressed air to clear tubes.	PURGE	Purge operation is required to remove non-condensables.

NOTE: Equipment failures caused by lack of adherence to the Maintenance Interval Requirements are not covered under warranty.

INDEX

- Abbreviations and explanations, 4
- Bearing and gear maintenance, 50
- Bearings, 10
- Bolt torque requirements, 20
- Chiller
 - Components, 7
 - Dehydration, 24
 - Familiarization, 4
 - Identification, 6
 - Information nameplate, 4
 - Leak test, 22
 - Limited shutdown, operation after, 40
 - Operating condition, checking, 37
 - Preparing for start-up, 40
 - Replacement parts, ordering, 51
 - Starting, 40
 - Stopping, 40
 - Tightness, checking, 19
- Cold weather operation, 41
- Compressor
 - Bearing and gear maintenance, 50
 - Description, 4
- Condenser
 - Description, 4
- Control Panel
 - Inspecting, 48
- Controller identification, modifying, 31
- Controls
 - Description, 15
 - PIC6 system components, 16
- Display messages, checking, 51
- Economizer
 - Description, 4
- Equipment required, 19
- Evaporator
 - Description, 4
- Extended shutdown
 - Preparing for, 40
 - Operation after, 40
- Field set up and verification, 35
- Filter, changing, 49
- Gasketed joints, tightening, 19
- Guide vanes
 - Checking, 46
 - Operation, manual, 41
- Heat exchanger tubes and flow devices, maintenance, 50
- High altitude locations, 55
- Initial start-up, 36
- Initial start-up checklist, *CL-1*
- Inspecting equipment, 50
- Instructing customer operator, 37
- Job data required, 19
- Leak test procedures (chart), 21
- Limited shutdown, operation after, 40
- Local start/stop control, 16
- Lubrication control, 17
- Lubrication cycle, 10
- Lubrication system, checking, 48
- Machine identification, 35
- Maintenance
 - General, 46
 - Scheduled, 48
 - Summary and log sheets, 89
 - Weekly, 48
- Motor rotation, checking, 36
- Operating instructions, 40
- Operator duties, 40
- Physical data, 55
- PIC6
 - Screen and menu reference, 85
 - System components, 16
- Piping
 - Inspecting before start-up, 25
 - Maintenance, 49
- Pressure transducers
 - Calibration, 54
 - Checking, 54
 - Recalibrating, 51
- Pumpout and refrigerant transfer, 43
- Quick test
 - Perform, 35
 - Use in troubleshooting, 55
- Refrigerant
 - Adding, 46
 - Adjusting charge, 46
 - Charge, 28
 - Float system, inspecting, 49
 - Leak rate, 46
 - Leak testing, 46
 - Properties, 46
 - Testing after service, repair, or major leak, 46
 - Tracer, 22
 - Trimming charge, 48
- Refrigeration cycle, 9
- Refrigeration log, 41,42
- Replacement parts, ordering, 51
- Running system, checking, 40
- Safety considerations, 2
- Safety valves
 - Checking before start-up, 25
 - Maintenance, 49
- Schedule, inputting local occupied, 31
- Sensor accuracy, checking, 54
- Service configurations, inputting, 31
- Service ontime, 48
- Service tables, configuring, 31
- Shipping packaging, removing, 19
- Shutdown
 - After extended, 40
 - After limited, 40
 - Local (with HMI), 18
 - Preparation for extended, 40
- Software configuration, 28
- Standing vacuum test, 22
- Start-Up
 - Accidental, preventing, 37
 - Before initial, 19
 - Chiller dehydration, 24
 - Control test (quick test), 35
 - Equipment required, 19
 - Field set up and verification, 35
 - Gasketed joints, tightening, 19
 - Initial, 36
 - Inspecting water piping, 25
 - Job data required, 19
 - Leak test, 22
 - Safety valves, checking, 25
 - Schedule, inputting local occupied, 31
 - Service configurations, inputting, 31
 - Shipping packaging, removing, 19
 - Software configuration, 28
 - Standing vacuum test, 22
 - Timing sequence, 17
 - Tracer, 22
- Start-up/shutdown/recycle sequence, 16
- Surge prevention, 37
- System components, 4
- Temperature sensors, checking, 51
- Thermistor temperature vs. resistance/voltage drop (C) 53
- Thermistor temperature vs. resistance/voltage drop (F) 52
- Time and date, inputting, 31
- Troubleshooting guide, 51
- Water
 - Leaks, 50
 - Treatment, 50
- Wiring
 - Bearing temperature sensors, 54
 - CCN for multiple chillers, 88
 - Control panel IOB layer, 63
 - HMI panel, 62

INITIAL START-UP CHECKLIST
FOR 19DV SEMI-HERMETIC TWO-STAGE CENTRIFUGAL LIQUID CHILLER
 (Remove and use for job file.)

NOTE: To avoid injury to personnel and damage to equipment or property when completing the procedures listed in this start-up checklist, use good judgment, follow safe practices, and adhere to the safety considerations/information as outlined in preceding sections of this Start-Up, Operation, and Maintenance Instructions document.

MACHINE INFORMATION:

NAME _____ SALES ORDER NO. _____
 ADDRESS _____ MODEL _____
 CITY _____ STATE _____ ZIP _____ S/N _____

DESIGN CONDITIONS:

	TONS (kW)	BRINE	FLOW RATE	TEMPERATURE IN	TEMPERATURE OUT	PRESSURE DROP	PASS	SUCTION TEMPERATURE	CONDENSER TEMPERATURE
EVAPORATOR									*****
CONDENSER								*****	

CHILLER LINE SIDE: Volts _____ FLA _____ OLTA _____

REFRIGERANT: Type: _____ Charge _____

CARRIER OBLIGATIONS:

Disassembled at Job Site	Yes <input type="checkbox"/>	No <input type="checkbox"/>
Assemble	Yes <input type="checkbox"/>	No <input type="checkbox"/>
Leak Test	Yes <input type="checkbox"/>	No <input type="checkbox"/>
Dehydrate	Yes <input type="checkbox"/>	No <input type="checkbox"/>
Charging	Yes <input type="checkbox"/>	No <input type="checkbox"/>
Operating Instructions _____ Hrs.		

**START-UP TO BE PERFORMED IN ACCORDANCE WITH APPROPRIATE MACHINE START-UP INSTRUCTIONS
 JOB DATA REQUIRED:**

- | | | |
|---|------------------------------|-----------------------------|
| 1. Machine Installation Instructions | Yes <input type="checkbox"/> | No <input type="checkbox"/> |
| 2. Machine Assembly, Wiring and Piping Diagrams | Yes <input type="checkbox"/> | No <input type="checkbox"/> |
| 3. Starting Equipment Details and Wiring Diagrams | Yes <input type="checkbox"/> | No <input type="checkbox"/> |
| 4. Applicable Design Data (see above) | Yes <input type="checkbox"/> | No <input type="checkbox"/> |
| 5. Diagrams and Instructions for Special Controls | Yes <input type="checkbox"/> | No <input type="checkbox"/> |

INITIAL MACHINE PRESSURE: _____

	YES	NO
Was Machine Tight?		
If Not, Were Leaks Corrected?		
Was Machine Dehydrated After Repairs?		

RECORD ACTUAL PRESSURE DROPS Evaporator _____ Condenser _____

CHARGE REFRIGERANT: Initial Charge _____ Final Charge After Trim _____

INSPECT WIRING AND RECORD ELECTRICAL DATA:

RATINGS:

Motor Voltage _____ Motor RLA _____ Chiller LRA Rating _____
Actual Line Voltages: VFD _____ Refrigerant (1TB L1/L2/L3) Pump _____ Controls (1TB LL1/LL2) _____
Verify 6-in. clearance surrounding all VFD enclosure louvers. Yes No
Record:

L1 to ground _____
L2 to ground _____
L3 to ground _____
L1 to L2 _____
L1 to L3 _____
L2 to L3 _____

NOTE: The % of voltage imbalance should be the same for the two different measurements
Visually inspect the top of the starter cabinet for penetrations and internally for metal particulate: Yes No
VFD Manufacturer _____ VFD Nameplate I.D. Number _____
VFD Serial Number _____ VFD Nameplate Input Rating _____
Mfd in _____ on _____

CONTROLS: SAFETY, OPERATING, ETC.

Perform Quick Calibration (Yes/No) _____

COMPRESSOR MOTOR AND CONTROL PANEL **MUST** BE PROPERLY AND INDIVIDUALLY CONNECTED BACK TO THE EARTH GROUND IN THE VFD (IN ACCORDANCE WITH CERTIFIED DRAWINGS). THE TRANSFORMER SUPPLYING POWER TO THE UNIT SHOULD BE A WYE SECONDARY WITH SOLIDLY GROUNDED NEUTRAL.

Yes _____

WATER/BRINE PUMP CONTROL: Can the Carrier controls independently start the pumps?

Condenser Water Pump Yes No
Chilled Water Pump Yes No

RUN MACHINE: Do these safeties shut down machine?

Condenser Water Flow Yes No
Chilled Water Flow Yes No
Pump Interlocks (optional) Yes No

INITIAL START:

Line up all valves in accordance with instruction manual: _____
Start water pumps and establish water flow: _____
Check refrigerant pump rotation-pressure: _____
Check compressor motor rotation (first stage suction housing sight glass) and record: Clockwise _____
Restart compressor, bring up to speed (operating for at least 2 minutes), and shut down.
Any abnormal coastdown noise? If yes, determine cause: Yes No

START MACHINE AND OPERATE. COMPLETE THE FOLLOWING:

- A: Trim charge and record under Charge Refrigerant section on page CL-1.
- B: Take at least two sets of operational log readings and record.
- C: Give operating instructions to owner's operating personnel. Given at: _____ Hours
- D: Call your Carrier factory representative to report chiller start-up.
- E: Return a copy of this checklist to the local Carrier Service office.

SIGNATURES:

CARRIER TECHNICIAN _____

CUSTOMER REPRESENTATIVE _____

DATE _____

DATE _____

CUT ALONG DOTTED LINE

CUT ALONG DOTTED LINE

19DV PIC6 SET POINT TABLE CONFIGURATION SHEET

DESCRIPTION	RANGE	UNITS	DEFAULT	VALUE
Cooling ECW Set point	-9.4 to 48.9	°C	15.6	
EWT Control Option	DISABLE/ENABLE	—	DSABLE	
Ice Build Set point	-9.4 to 15.6	°C	4.4	
Cooling LCW Set point	-12.2 to 48.9	°C	7.2	
Base Demand Limit	10.0 to 100.0	%	100.0	

PIC6 TOUCH SCREEN Software Version Number: _____

PIC6 TOUCH SCREEN Controller Identification: BUS: _____ ADDRESS: _____

19DV PIC6 TIME SCHEDULE CONFIGURATION SHEET PERIOD 1

	DAY FLAG								OCCUPIED TIME				UNOCCUPIED TIME			
	M	T	W	T	F	S	S	H								
Period 1:																
Period 2:																
Period 3:																
Period 4:																
Period 5:																
Period 6:																
Period 7:																
Period 8:																

19DV PIC6 TIME SCHEDULE CONFIGURATION SHEET PERIOD 2

	DAY FLAG								OCCUPIED TIME				UNOCCUPIED TIME			
	M	T	W	T	F	S	S	H								
Period 1:																
Period 2:																
Period 3:																
Period 4:																
Period 5:																
Period 6:																
Period 7:																
Period 8:																

19DV PIC6 TIME SCHEDULE CONFIGURATION SHEET PERIOD 3

	DAY FLAG								OCCUPIED TIME				UNOCCUPIED TIME			
	M	T	W	T	F	S	S	H								
Period 1:																
Period 2:																
Period 3:																
Period 4:																
Period 5:																
Period 6:																
Period 7:																
Period 8:																

19DV PIC6 FACTORY TABLE CONFIGURATION SHEET

DESCRIPTION	RANGE	UNITS	DEFAULT	VALUE
Chiller Type 19XR6/7=0,19XR2-E/D/V=1, 19DV=2	0 to 2		0	
Unit Type Cool Only=0,Heat Mach=1	0 to 1		0	
Comp(Single=0,Dual=1)	0 to 1		0	
Chilled Medium Type Water =0, Brine =1	0 to 1		0	
19DV Comp Design Press 44PSI=0 72PSI=1	0 to 1		0	
Free Cooling Option	0 to 1		0	
VFD Option No=0,FS VFD=1,Carrier=2 Rockwell LF2=3, Eaton=4 Rockwell STD=5	0 to 5		0	
IOB4 Option	0 to 1		0	
Guide Vane1 Type Digital=0 Analog=1	0 to 1		0	
Marine Option	0 to 1		0	
Power Request Option	0 to 1		0	
Cont. Power Request	0 to 1		0	
Purge System Option	0 to 1		0	
Liquid Bypass Option	0 to 1		0	

19DV PIC6 CFG_19DV CONFIGURATION TABLE CONFIGURATION SHEET

DESCRIPTION	RANGE	UNITS	DEFAULT	VALUE
Motor Pole Pair Single=1 Double=2	1 to 2		1	
IGV2 Travel Limit	30 to 100	%	96.0	
IGV2 Minimum Degree	0 to 20	Deg.	2.0	
IGV2 Fully Open Degree	10 to 100	Deg.	90.0	
IGV2 Actuator Max	90 to 120	Deg.	94.0	
IGV2 Position @IGV1 20°	10 to 30	Deg.	28.1	
IGV2 Position @IGV1 30°	10 to 50	Deg.	37.2	
IGV2 Position @IGV1 50°	10 to 80	Deg.	71.6	
VFD Rate Speed Hz	10 to 200	Hz	80.5	
Purge Regen Lasting Time	0 to 65535	min	120	
Daily PG Pumpout Limit	20 to 200	min	50	

19DV PIC6 CFGSURGE_SURGE CORRECTION CONFIG TABLE CONFIGURATION SHEET

DESCRIPTION	RANGE	UNITS	DEFAULT	VALUE
Surge Line Configuration PR = 0, Delta T = 1	0 to 1		0	
IGV1 POS Configuration Degree =0, Percentage =1	0 to 1		0	
Surge Delta Tmax	0 to 150	°F	70	
Surge Delta Tmin	0 to 150	°F	45	
IGV1 Full Load Open Deg.	80.0 to 120.0	Deg.	88.0	
IGV1 Minimum Open Deg.	0.0 to 10.0	Deg.	2.0	
IGV1 Actuator Max Deg.	90.0 to 120.0	Deg.	109.0	
IGV1 Minimum Position	0.0 to 100.0	%	5.0	
IGV1 Full Load Position	0.0 to 100.0	%	100.0	
Envelope Line Offset	0.1 to 3.0	°F	2.0	
Envelope Speed Factor	0.00 to 3.00		2.0	
Surge Line Shape Factor	-1.000 to 0.000		-0.01	

19DV PIC6 CFGGEVFD_GENERAL VFD CONFIG TABLE CONFIGURATION SHEET

DESCRIPTION	RANGE	UNITS	DEFAULT	VALUE
VFD Max Speed Per	90 to 110	%	100	
VFD Min Speed Per	65 to 89	%	70	
VFD Start Speed Per	45 to 100	%	100	
VFD Current Limit	0 to 99999	AMPS	250	

CUT ALONG DOTTED LINE

CUT ALONG DOTTED LINE

19DV PIC6 CFGUMVFDUM VFD CONFIGURATION TABLE CONFIGURATION SHEET

DESCRIPTION	RANGE	UNITS	DEFAULT	VALUE
Compressor Speed 100%	47 to 200	Hz	50	
Motor Rated Line Voltage	200 to 13800	Volts	460	
Motor Nameplate Current	10 to 2000	AMPS	200	
Motor Rated Load Current	10 to 2000	AMPS	200	
Motor Nameplate Voltage	200 to 13800	Volts	460	
Motor Nameplate RPM	1500 to 5000	rpm	3000	
Motor Nameplate KW	0 to 5600	KW	1500	
Skip Frequency 1	0.0 to 102	Hz	30	
Skip Frequency 2	0.0 to 102	Hz	30	
Skip Frequency 3	0.0 to 102	Hz	30	

19DV PIC6 SERVICE PARAMETERS TABLE CONFIGURATION SHEET

DESCRIPTION	RANGE	UNITS	DEFAULT	VALUE
Atmospheric Pressure	8.000 to 15.000	PSI	14.5	
GV1 Travel Limit	30 to 100	%	80.7	
GV1 Closure at Startup	0 to 40	%	4	
Controlled Fluid DB	0.5 to 2	^F	1	
Demand Limit At 20 mA	10 to 100	%	40	
Demand Limit Prop Band	3 to 15	%	10	
Amps or KW Ramp per Min	5 to 20	%	5	
Temp Ramp per Min	1 to 10	^F	3	
Recycle Shutdown Delta T	0.5 to 4	^F	1	
Recycle Restart Delta T	2 to 10	^F	5	
Soft Stop Amps Threshold	40 to 100	%	70	
Water Flow Verify Time	0.5 to 5	min	5	
Power Calibration Factor	0.5 to 2	—	1	
Enable Excessive Starts	0 to 1	—	0	
Purge Active Temp SP	30 to 90	—	65	

19DV PIC6 OPTION CONFIGURATION TABLE (CONF_OPT) CONFIGURATION SHEET

DESCRIPTION	RANGE	UNITS	DEFAULT	VALUE
Auto Restart Option	0 to 1		0	
Common Sensor Option	0 to 1		0	
EC Valve Option No=0, Cont.=1 ON/OFF=2, mA=3	0 to 3		0	
EC Selection Disable=0, Surge=1 Low Load=2, Comb=3	0 to 3		0	
Ice Build Option	0 to 1		0	
Water Flow Determination	0 to 1		0	
Liquid Bypass Selection	0 to 1		0	
Purge On Idle Option	0 to 1		0	

19DV PIC6 GENERAL PARAMETERS TABLE (GENUNIT) CONFIGURATION SHEET

DESCRIPTION	RANGE	UNITS	DEFAULT	VALUE
Cooling/Heating Select	0 to 1			

19DV PIC6 SETPOINT TABLE CONFIGURATION SHEET

DESCRIPTION	RANGE	UNITS	DEFAULT	VALUE
Cooling ECW Setpoint	15 to 120	°F	60	
Cooling LCW Setpoint	-12.2 to 48.9	°F	45	
ICE Build Setpoint	-9.4 to 15.6	°F	104	
Heating ECDW Setpoint	17.2 to 65.6	°F	113	
Heating LCDW Setpoint	20 to 65.6	°F	40	
Base Demand Limit	10.0 to 100.0	%	100.0	

ALARM SHUTDOWN STATE RECORD SHEET

PRIMARY MESSAGE	DATE	TIME	CHW IN	CHW OUT	EVAP REF	CDW IN	CDW OUT	COND REF	AMPS%

CUT ALONG DOTTED LINE

CUT ALONG DOTTED LINE