

Viper 650/850 Robot with eMB-60R

User's Guide



Copyright Notice

The information contained herein is the property of Omron Adept Technologies, Inc., and shall not be reproduced in whole or in part without prior written approval of Omron Adept Technologies, Inc. The information herein is subject to change without notice and should not be construed as a commitment by Omron Adept Technologies, Inc. The documentation is periodically reviewed and revised.

Omron Adept Technologies, Inc., assumes no responsibility for any errors or omissions in the documentation. Critical evaluation of the documentation by the user is welcomed. Your comments assist us in preparation of future documentation. Please submit your comments to: techpubs@adept.com.

Copyright © 2007, 2010 - 2012, 2016 - 2019 by Omron Adept Technologies, Inc.
All rights reserved.

Any trademarks from other companies used in this publication are the property
of those respective companies.

Created in the United States of America

Table of Contents

Chapter 1: Introduction	9
1.1 Product Description	9
SmartController EX (Option)	10
eMotionBlox-40/60R	10
1.2 How Can I Get Help?	11
Corporate Web Site	11
Related Manuals	12
Chapter 2: Safety	13
2.1 Dangers, Warnings, and Cautions	13
Alert Levels	13
Alert Icons	13
Falling Hazards	13
Special Information	14
2.2 What to Do in an Emergency or Abnormal Situation	14
Releasing the Brakes	14
Releasing an E-Stop	14
2.3 Safety Precautions	15
User's Responsibilities	15
General Hazards	16
Qualification of Personnel	16
2.4 Robot Behavior	17
Hardstops	17
Limiting Devices	17
Singularities	17
2.5 Intended and Non-intended Use	17
Intended Use	17
Non-Intended Use	17
Robot Modifications	18
2.6 Additional Safety Information	18
Manufacturer's Declaration of Incorporation	18
Robot Safety Guide	18
Manual Control Pendant (option)	18
2.7 Disposal	19
Chapter 3: Robot Installation	21
3.1 Unpacking and Inspecting the Equipment	21
3.2 Repacking for Relocation	21

3.3 Environmental and Facility Requirements	22
3.4 Transporting the Robot	23
Precautions when Transporting Robot	23
Transport Procedure	24
3.5 Mounting the Robot	26
3.6 Grounding the Robot	27
3.7 Mounting the Front Panel	27
3.8 Description of Connectors on Robot Interface Panel	28
3.9 Air Lines and Signal Wiring	28
Optional Solenoid Cable	30
Solenoid Valve Specifications	32
External Mounting Locations on Robot	33
3.10 Designing End-Effectors	33
Continuous Turn on J6	33
Mass of End-Effector	33
Center of Gravity Position of End-Effector	34
Moment of Inertia Around J4, J5, and J6	34
Chapter 4: eMotionBlox-40/60R	39
4.1 Introduction	39
4.2 Connectors on eMB-40/60R Interface Panel	40
4.3 eMB-40/60R Operation	41
Status LED	41
Status Panel	42
Brake Release Button	43
Brake Release Connector	44
4.4 Connecting Digital I/O to the System	45
4.5 Using Digital I/O on eMB-40/60R XIO Connector	46
Optional I/O Products	48
XIO Input Signals	48
XIO Output Signals	50
XIO Breakout Cable	52
4.6 Mounting the eMB-40/60R	54
Dimensions and Mounting Holes	54
Mounting Clearances	55
Chapter 5: System Installation	57
5.1 System Cables, without SmartController EX	57
List of Cables and Parts	58
Cable Installation Overview	59
5.2 System Cables, with SmartController EX	61

Installing a SmartController EX Motion Controller	61
List of Cables and Parts	62
Cable Installation Overview	63
5.3 Optional Cables	64
XIO Breakout Cable	64
DB9 Splitter Cable	64
eAIB XBELT IO Adapter Cable	64
SmartController EX Belt Encoder Y-Adapter Cable	64
5.4 ACE Software	68
5.5 Connecting Cables from the eMB-40/60R to the Robot	69
5.6 Connecting 24 VDC Power to eMB-40/60R Servo Controller	70
Specifications for 24 VDC Power	70
Details for 24 VDC Mating Connector	71
Procedure for Creating 24 VDC Cable	71
Installing the 24 VDC Cable	72
5.7 Connecting 200-240 VAC Power to eMB-40/60R	73
Specifications for AC Power	73
Facility Overvoltage Protection	74
AC Power Diagrams	75
Details for AC Mating Connector	76
Procedure for Creating 200-240 VAC Cable	76
Installing AC Power Cable to eMB-40/60R	77
5.8 Grounding the Robot System	77
Ground Point on Robot Base	78
Ground Point on eMotionBlox-40/60R	78
Robot-Mounted Equipment Grounding	79
5.9 Installing User-Supplied Safety Equipment	79
Emergency Stop Circuits	85
Remote Manual Mode	87
User Manual/Auto Indication	87
User High Power On Indication	88
Remote High Power On/Off Control	88
High Power On/Off Lamp	88
Remote Front Panel or User-Supplied Control Panel Usage	88
Remote Pendant Usage	89
Chapter 6: System Operation	91
6.1 Status Panel Codes	91
6.2 Brakes	91
Installing and Using the Brake Release Box	91
Using the Brake Release Switch on UL Robots	92
6.3 Front Panel	93
6.4 Starting the System for the First Time	95
Verifying Installation	95

System Start-up Procedure	96
Running the ACE Software	96
Verifying E-Stop Functions	97
Verify Robot Motions	98
6.5 Learning to Program the Robot	98
6.6 Installing Joint Labels	99
6.7 Caution Label on Robot	100
Chapter 7: Maintenance	101
7.1 Field-replaceable Parts	101
7.2 Periodic Maintenance Schedule	101
7.3 Checking Safety Systems	102
7.4 Checking Robot Mounting Bolts	102
7.5 Replacing Encoder Backup Batteries	102
Battery Replacement Intervals	102
Battery Replacement Procedure	102
7.6 Replacing the eMB-40/60R Amplifier	106
Remove the eMB-40/60R Amplifier	106
Installing a New eMB-40/60R	107
7.7 Commissioning a System with an eMB-40/60R	107
Safety Commissioning Utilities	108
E-Stop Configuration Utility	109
E-Stop Verification Utility	110
Teach Restrict Configuration Utility	110
Teach Restrict Verification Utility	111
7.8 Changing the Lamp in the Front Panel High-Power Indicator	112
Chapter 8: Technical Specifications	115
8.1 Robot Dimensions	115
8.2 Robot Flange Dimensions	119
8.3 Specifications	120
Physical	120
Performance	121
Stopping Distances and Times	122
Chapter 9: IP54/65 Option	129
9.1 Introduction	129
9.2 Differences from the Standard Robot Model	130
Installation Environment	130
Robot Connector Panel	130
Cable Clearance	131

Replacing Encoder Backup Battery	131
Chapter 10: Cleanroom Option	133
10.1 Introduction	133
10.2 Differences from Standard Robot Model	133
Cleanroom Technical Specifications	134
Robot Connector Panel	134
10.3 Air Lines and Signal Wiring	135
10.4 Cleanroom Cover at J6 Flange	137
10.5 Cable Clearance	138
10.6 Replacing Encoder Backup Battery	138
Chapter 11: Status Codes	139
11.1 Introduction	139
Status Panel Display	139
Status Panel	139

Revision History

Revision code	Date	Revised Content
01	April, 2016	Original release
02	January, 2017	Added ISO-required text for stopping distances and times.
03	July, 2017	<ul style="list-style-type: none"> • Added photos showing good and bad connections for the Arm Power/Signal Cable; added to related text. • Noted how Cleanroom Arm Power/Signal Cable connects in Options chapter. • Corrected ambient temperature to 5 to 40°C.
04	October, 2018	<ul style="list-style-type: none"> • Changed transport and lift position of joints to match what the user will receive. • Updated Safety chapter to newer format. • Added WEEE information. • Changed eAIB to eMB-40/60R in several places. • Added graphics of display panel LED to eMB-40/60R chapter. • Added display panel codes chapter.
05	March, 2019	<ul style="list-style-type: none"> • Copyright date updated to include 2019. • Corrected bore hole distance. • Revised encoder battery replacement procedure. • Updated Safety chapter with latest information. • Removed duplicated chapter 5. • System Installation chapter added as chapter 5. • Changed XMCP jumper plug P/N from 04737-000 to 10052-000. • Changed T20 Pendant P/N from 10055-000 to 10054-010. • Removed references to obsolete sDIO units from table 4-5 (optional sDIO Module, connects to controller), figure 4-4, table 4-6, and table 1-1. • Dual robot configuration guide renamed to single and multiple robot configuration guide. • Added call outs to figures. • Added humidity range of 5% to 90% to table 3-1; previously it noted 90% or less. • Moved optional cable information and System Cables, with Two Conveyor Encoders section to new section 5.3 Optional Cables. This section includes new details and figures to illustrate all encoder cable configurations and pinouts. • Minor text changes to Line E-Stop Input and Emergency Stop Circuits sections in Chapter 5: System Installation. • Added part number for IEEE 1394 cable in Chapter 5: System Installation. • Changed ACE software disk to ACE software media. • Added a note about typical IO Blox configurations in Chapter 4: eMotionBlox-40/60R.

Chapter 1: Introduction

1.1 Product Description

The Viper 650 robot and Viper 850 robots are high-performance, six-joint robots designed specifically for assembly applications. The speed and precision of the Viper robots also make them ideal for material handling, packaging, machine tending, and many other operations requiring fast and precise automation.

NOTE: The descriptions and instructions in this manual apply to both the Viper 650 and the Viper 850 robots, except for instances where there is a difference, as in dimension and work envelope drawings. In those cases, the information is presented for both robots. The robot motors are powered by an eMB-40/60R servo-controller/amplifier. Either robot can be controlled by the eMB-40/60R, running eV+, or an optional SmartController EX motion controller.

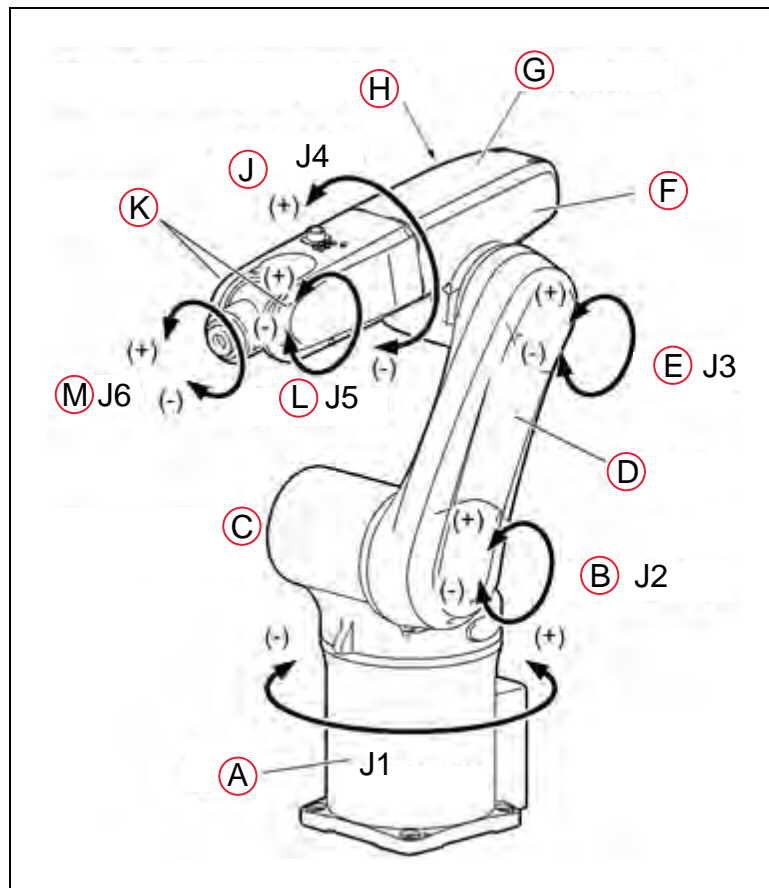

Figure 1-1. Robot Joint Identification

Key	Meaning	Key	Meaning
A	Base (1st Joint)	G	2nd Arm
B	2nd Joint	H	3rd joint motor cover (rear side)
C	3rd joint motor cover (rear side)	J	4th Joint
D	1st Arm	K	2nd arm cover
E	3rd Joint	L	5th Joint
F	4th joint cover	M	6th Joint

SmartController EX (Option)

The SmartController EX motion controller is the foundation of our family of high-performance distributed motion and vision controllers. The SmartController EX is designed for use with:

- eCobra robots
- Quattro robots
- Viper robots
- Hornet robots

The SmartController EX supports a conveyor tracking option, as well as other options. The SmartController EX uses the eV+ Operating System (as does the eMB-40/60R). It offers scalability and support for IEEE 1394-based digital I/O and general motion expansion modules. The IEEE 1394 interface is the backbone of SmartServo, the distributed controls architecture supporting our products. The SmartController also includes Fast Ethernet and DeviceNet.

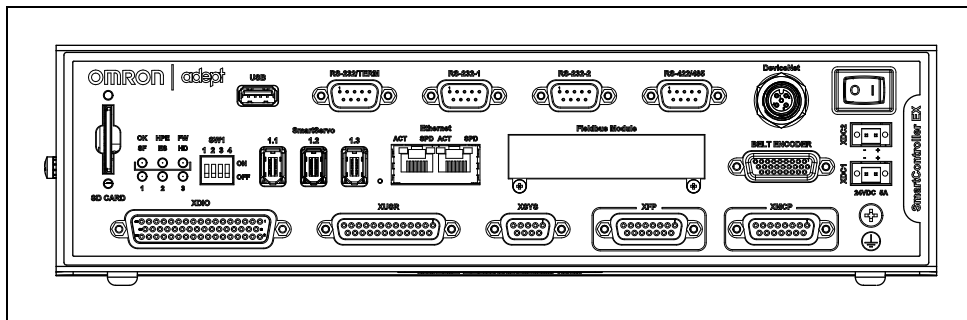

Figure 1-2. SmartController EX Motion Controller

eMotionBlox-40/60R

The eMotionBlox-40/60R (eMB-40/60R) distributed servo controller contains the amplifiers to power the high-power motors of the Viper 650/850 robots, and runs the eV+ operating system for motion control.

The eMB-40/60R features:

- Six AC servo motor amplifiers
- Emergency stop circuitry

- High servo rate, to deliver low positional errors and superior path following
- Sine wave commutation, for low cogging torque and improved path following
- Digital feed-forward design, to maximizes efficiency, torque, and velocity
- Integral temperature sensors and status monitoring for maximum reliability
- Dual-digit diagnostics display for easy troubleshooting

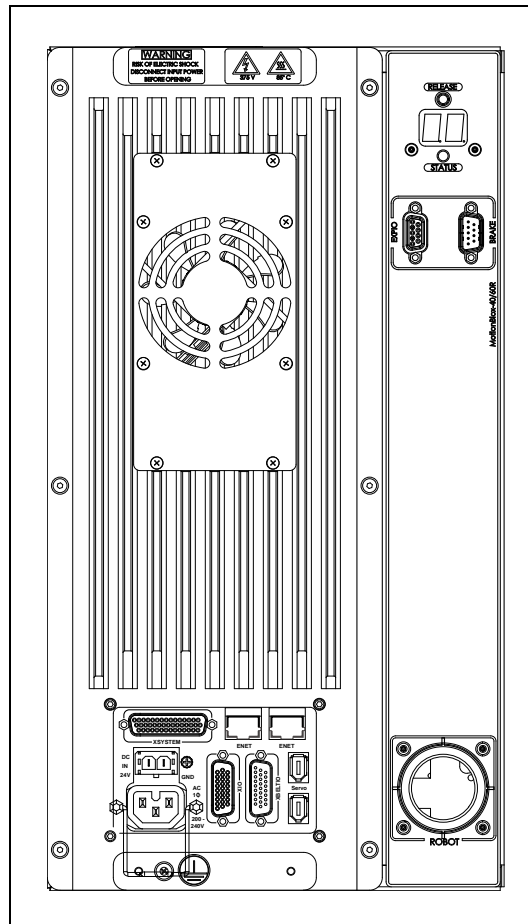

Figure 1-3. eMotionBlox-40/60R (eMB-40/60R)

1.2 How Can I Get Help?

Corporate Web Site

You can access information sources on our corporate web site:

<http://www.ia.omron.com>

Related Manuals

This manual covers the installation, operation, and maintenance of a Viper 650/850 robot system. There are additional manuals that cover programming the system, reconfiguring installed components, and adding other optional components. See the following table.

Table 1-1. Related Manuals

Manual Title	Description
<i>Robot Safety Guide</i>	Contains general safety information for all of our robots. A printed copy of this guide ships with each robot.
<i>SmartController EX User's Guide</i>	Contains complete information on the installation and operation of the optional SmartController EX.
<i>T20 Pendant User's Guide</i>	Describes the T20 pendant.
<i>IO Blox User's Guide</i>	Describes the IO Blox product.
<i>ACE User's Guide</i>	Describes the installation and use of the ACE software.
<i>Single and Multiple Robot Configuration Guide</i>	Contains cable diagrams and configuration procedures for a single and multi-robot system.

2.1 Dangers, Warnings, and Cautions

Alert Levels

There are three levels of alert notation used in our manuals. In descending order of importance, they are:



DANGER: Identifies an imminently hazardous situation which, if not avoided, is likely to result in serious injury, and might result in fatality or severe property damage.



WARNING: Identifies a potentially hazardous situation which, if not avoided, will result in minor or moderate injury, and might result in serious injury, fatality, or significant property damage.



CAUTION: Identifies a potentially hazardous situation which, if not avoided, might result in minor injury, moderate injury, or property damage.

Alert Icons

The icon that starts each alert can be used to indicate the type of hazard. These will be used with the appropriate signal word - Danger, Warning, or Caution - to indicate the severity of the hazard. The text following the signal word will specify what the risk is, and how to avoid it.

Icon	Meaning	Icon	Meaning
	This is a generic alert icon. Any specifics on the risk will be in the text following the signal word.		This identifies a hazardous electrical situation.

Falling Hazards



WARNING: PERSONAL INJURY OR PROPERTY DAMAGE RISK
If mounted incorrectly, the robot can fall over and cause serious injury to personnel or damage to itself or other equipment.

Safety Barriers

To protect personnel from coming in contact with robot unintentionally or objects entering robot's operation zone, install user-supplied safety barriers in the workcell.

Special Information

There are several types of notation used to call out special information.

IMPORTANT: Information to ensure safe use of the product.

NOTE: Information for more effective use of the product.

Additional Information: Offers helpful tips, recommendations, and best practices.

Version Information: Information on differences in specifications for different versions of hardware or software.

2.2 What to Do in an Emergency or Abnormal Situation

Press any E-Stop button (a red push-button on a yellow background) and then follow the internal procedures of your company or organization for an emergency or abnormal situation. If a fire occurs, use CO₂ to extinguish the fire.

Releasing the Brakes

In case of an emergency or abnormal situation, the joints of the robot can be manually moved without high voltage. However, only qualified personnel who have read and understood the robot user's guide and *Robot Safety Guide* should manually move the robot into a safe state. See Brakes on page 91.



WARNING: PERSONAL INJURY RISK

Viper robots are not collaborative robots. They require a dedicated work area that will prevent personnel from coming into contact with them during operation.

Releasing an E-Stop



CAUTION: PERSONAL INJURY OR PROPERTY DAMAGE RISK

If the robot's E-Stop is triggered, ensure that the cause of the E-Stop is resolved, before releasing the E-Stop.

After the E-Stop button has been manually released, the robot will wait until the motors are manually enabled.

There are two ways to enable the motors:

- Enable power through ACE software installed on your PC
- Press the ROBOT POWER button on the Pendant

Once the motors are enabled, the robot will wait two seconds and then resume commanded motion, if there is adequate space to maneuver.

2.3 Safety Precautions



WARNING: PERSONAL INJURY OR PROPERTY DAMAGE RISK
A Viper robot can cause serious injury or death, or damage to itself and other equipment, if the safety precautions in this manual are not observed.



WARNING: ELECTROCUTION RISK
During maintenance, disconnect AC power from the robot, and install a lock-out tag-out to prevent anyone from reconnecting power.

User's Responsibilities

Safe use of Viper robots is your responsibility. To ensure compliance with safety rules and regulations:

- All personnel who install, operate, teach, program, or maintain a Viper system must read this guide, read the *Robot Safety Guide*, and complete a training course for their responsibilities in regard to the robot.
- All personnel who design a Viper robot system must read this guide, read the *Robot Safety Guide*, and must comply with all local and national safety regulations for the location in which the robot is installed.



Figure 2-1. Read Manual and Impact Warning Labels

- The Viper system must not be used for purposes other than described in Intended Use on page 17. Contact your local Omron support if you are not sure of the suitability for your application.
- The environment must be suitable for safe operation of the robot.
- The user is responsible for providing safety barriers around the robot to prevent anyone from accidentally coming into contact with the robot when it is in motion.
- Power to the robot and its power supply must be locked out and tagged out before any maintenance is performed.

- The Vipers must be well maintained, so that their control and safety functions continue to work properly.

General Hazards

IMPORTANT: The following situations could result in injury or damage to the equipment.

- Do not place objects on the robot.
- Do not exceed the maximum payload capacity.
- Do not exceed the maximum limits given in technical specifications. See Technical Specifications on page 115.
- Do not drop the robot, put weights on it or otherwise operate it irresponsibly.
- Do not use unauthorized parts.

Qualification of Personnel

It is the end-user's responsibility to ensure that all personnel who will work with or around robots have attended an appropriate Omron training course and have a working knowledge of the system. The user must provide the necessary additional training for all personnel who will be working with the system.

As noted in this and the Robot Safety Guide, certain procedures should be performed only by skilled or instructed persons. For a description of the level of qualification, we use the standard terms:

- **Skilled persons** have technical knowledge or sufficient experience to enable them to avoid the dangers, electrical and/or mechanical
- **Instructed persons** are adequately advised or supervised by skilled persons to enable them to avoid the dangers, electrical and/or mechanical

All personnel must observe industry-prescribed safety practices during the installation, operation, and testing of all electrically-powered equipment.

IMPORTANT: Before working with the robot, every entrusted person must confirm that they:

- Have the necessary qualifications
- Have received the guides (both this user's guide, and the Robot Safety Guide)
- Have read the guides
- Understand the guides
- Will work in the manner specified by the guides

2.4 Robot Behavior

Hardstops

If the Viper runs into one of its hardstops, the robot's motion will stop completely, an envelope error will be generated, and power will be cut to the robot motors.

The robot cannot continue to move after hitting a hardstop until the error has been cleared.

The Viper's hardstops are capable of stopping the robot at any speed, load, and maximum or minimum extension.

Limiting Devices

There are no dynamic or electro-mechanical limiting devices provided by Omron Adept Technologies, Inc. The robot does not have safety-rated soft axis or space limiting.

However, the user can install their own safety rated (category 0 or 1) dynamic limiting devices if needed, that comply with ISO 10218-1, Clause 5.12.2.

Singularities

There are no singularities with a Viper robot that cause a hazard.

2.5 Intended and Non-intended Use

Intended Use

The normal and intended use of these robots does not create hazards. The Viper robots have been designed and constructed in accordance with the relevant requirements of IEC 60204-1.

The Viper robots are intended for use in parts assembly and material handling for payloads less than 5 kg (11 lb). See Specifications on page 120 for complete information on the robot specifications. Refer to the *Robot Safety Guide* for details on the intended use of robots.



WARNING: PERSONAL INJURY RISK

Viper robots are not collaborative robots. They require a dedicated work area that will prevent personnel from coming into contact with them during operation.

Guidelines for safe use:

- Clean, dry mounting surfaces — The robot shall not be installed in an environment where it will be directly exposed to water, oil, or cutting chips.
- Temperature — 5 to 40°C (41 to 104°F), with a recommended humidity range of 5% to 90%, non-condensing.

Non-Intended Use

Viper robots are not intended for use in any of the following situations:

- Use in the presence of ionizing or non-ionizing radiation
- Use in potentially explosive atmospheres

- Use in medical or life saving applications
- Use in a residential setting. They are for industrial use only
- Use before performing a risk assessment
- Where the equipment will be subject to extremes of heat or humidity

Non-intended use of Vipers can:

- Cause injury to personnel
- Damage itself or other equipment
- Reduce system reliability and performance

If there is any doubt concerning the application, ask your your local Omron support to determine if it is an intended use or not.

Robot Modifications

If the user or integrator makes any changes to the robot, it is their responsibility to ensure that there are no sharp edges, corners, or protrusions.

Note that any change to the robot can lead to loss in safety or functionality. The user or integrator must ensure that all safety features are operational after modifications.

2.6 Additional Safety Information

Contact your local Omron support for other sources of safety information:

Manufacturer's Declaration of Incorporation

This lists all standards with which the robot complies. The Manufacturer's Declarations for the Viper robot and other products are in the *Manufacturer's Declarations Guide*.

Robot Safety Guide

The *Robot Safety Guide* provides detailed information on safety for fixed robots. It also gives resources for more information on relevant standards. It ships with each robot.

Manual Control Pendant (option)

The E-Stop provided in the T20 Pendant complies with ISO 10218-1 (per clause 5.5.2), with stop category 1 (per IEC 60204). The E-stop button complies with ISO 13850. The E-Stop meets the requirements of PL-d per ISO 13849.

The protective stop category for the pendant enable switch is category 1, which complies with the requirements of ISO 10218-1.

NOTE: Omron Adept Technologies, Inc. does not offer a cableless (wireless) pendant.

The manual control pendant can only move one robot at a time, even if multiple robots are connected to a SmartController, and the pendant is connected to the SmartController.

2.7 Disposal



Dispose of in accordance with applicable regulations.

Customers can contribute to resource conservation and protecting the environment by the proper disposal of WEEE (Waste Electronics and Electrical Equipment). All electrical and electronic products should be disposed of separately from the municipal waste system via designated collection facilities. For information about disposal of your old equipment, contact your local Omron support.

Chapter 3: Robot Installation

3.1 Unpacking and Inspecting the Equipment

Carefully inspect all shipping crates for evidence of damage during transit. If any damage is apparent, request that the carrier's agent be present at the time the container is unpacked.

Before signing the carrier's delivery sheet, please compare the actual items received (not just the packing slip) with your equipment purchase order and verify that all items are present and that the shipment is correct and free of visible damage.

If the items received do not match the packing slip, or are damaged, do **not** sign the receipt. Contact your local Omron support as soon as possible.

If the items received do not match your order, please contact your local Omron support immediately.

Inspect each item for external damage as it is removed from its container. If any damage is evident, contact your local Omron support.

Retain all containers and packaging materials. These items may be necessary to settle claims or, at a later date, to relocate equipment.

3.2 Repacking for Relocation

If the robot or other equipment needs to be relocated, reverse the steps in the installation procedures that follow in this chapter. Reuse all original packing containers and materials and follow all safety notes used for installation. Improper packaging for shipment will void your warranty. Specify this to the carrier if the robot is to be shipped.



CAUTION: Before transportation, set the robot in a transport position by manually moving the second, third, and fourth axes. See the following figure.

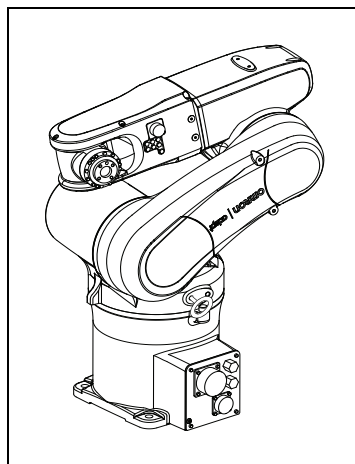

Figure 3-1. Robot in Transport Position

3.3 Environmental and Facility Requirements

The robot system installation must meet the operating environment requirements shown in the following table.

Table 3-1. Robot System Operating Environment Requirements

Item	Condition
Flatness of the mounting surface	0.1 mm/500 mm
Installation type	Floor-mount or Overhead-mount
Ambient temperature	During operation: 5 to 40°C (41 to 104° F) During storage and transportation: -25 to 60°C
Humidity	During operation: 5% to 90% (Non-condensing) During storage and transportation: 75% or less (Non-condensing)
Altitude	up to 1000 m
Vibration	During operation: 4.9 m/s ² (0.5 G) or less During storage and transportation: 29.4 m/s ² (3 G) or less
Safe Installation Environment	The robot should not be installed in an environment where: <ul style="list-style-type: none"> • There are flammable gases or liquids • There are any acidic, alkaline, or other corrosive gases • There is sulfuric or other types of cutting or grinding oil mist • There are any large-sized inverters, high output/high frequency transmitters, large contractors, welders, or other sources of electrical noise • There are any shavings from metal processing or other conductive material flying about • It may be directly exposed to water, oil, or cutting chips
Working space, etc.	<ul style="list-style-type: none"> • Sufficient service space must be available for inspection and disassembly. • Keep wiring space (230 mm or more) behind the robot, and fasten the wiring to the mounting face or beam so that the weight of the cables will not be directly applied to the connectors.
Protective Earth Ground	Grounding resistance: 10 Ω or less See Robot Installation on page 21.

3.4 Transporting the Robot

Precautions when Transporting Robot

- The robots weigh 34 and 36 kg (74 and 79 lb). Use a crane suitable for the robot weight.
- Have at least two workers handle this job.
- Workers should wear hardhats, safety shoes, and gloves during transport.
- Do not hold the first arm, elbow, either side of the 2nd arm, 2nd-joint cover, or 3rd-joint cover, or apply force to any of them. See Robot Joint Identification on page 9.



WARNING: Do not attempt to lift the robot at any points other than the eye-bolts provided. Do not attempt to move any robot links until the robot has been secured in position. Failure to comply could result in the robot falling and causing either personnel injury or equipment damage.

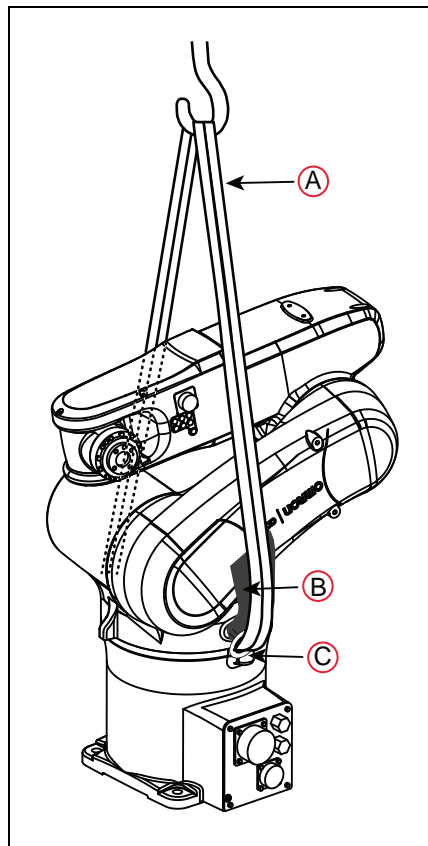
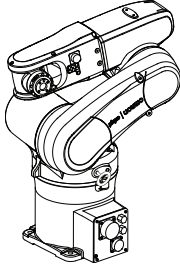
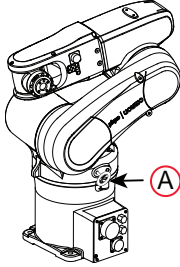
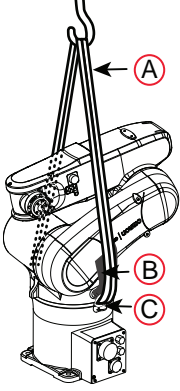



Figure 3-2. Robot in Hoisting Sling

Key	Meaning	Key	Meaning
A	Sling	C	Eyebolt
B	Waste Cloth		

Transport Procedure

Step	Procedure	Drawing												
1	<p>Before transportation, set the robot in a transport position as shown at right by manually moving the second, third, and fourth joints.</p> <p>When initially unpacked, the robot is in the transport position, so this step is not required.</p>	<div style="text-align: center;">  </div> <p style="text-align: center;">Transport Position</p> <table border="1" style="width: 100%; border-collapse: collapse;"> <thead> <tr> <th style="width: 60%;">Joint</th> <th>Angle</th> </tr> </thead> <tbody> <tr> <td>First joint (J1)</td> <td>90°</td> </tr> <tr> <td>Second joint (J2)</td> <td>-155°</td> </tr> <tr> <td>Third joint (J3)</td> <td>+245°</td> </tr> <tr> <td>Fourth joint (J4)</td> <td>-90°</td> </tr> <tr> <td>Fifth joint (J5)</td> <td>-90°</td> </tr> </tbody> </table>	Joint	Angle	First joint (J1)	90°	Second joint (J2)	-155°	Third joint (J3)	+245°	Fourth joint (J4)	-90°	Fifth joint (J5)	-90°
Joint	Angle													
First joint (J1)	90°													
Second joint (J2)	-155°													
Third joint (J3)	+245°													
Fourth joint (J4)	-90°													
Fifth joint (J5)	-90°													
2	<p>Disconnect the robot control cable, air hoses, and user signal cables from the robot.</p> <p>When the robot is first unpacked, this step is not required.</p>													
3	<p>As shown at right, mount the eye-bolts.</p> <p>When delivered, the robot is packed with eyebolts attached, so this step is not required.</p> <p>(A) is one of two eyebolts.</p>	<div style="text-align: center;">  </div>												

Step	Procedure	Drawing
4	<p>As shown at right, place a waste cloth on the second joint and pass the sling through the two eyebolts.</p> <p>Note: Before transporting the robot, check that the path to the mounting location is free of obstacles. Callouts are defined following Figure 3-2. (A) is the sling, (B) is a waste cloth for padding, (C) is one of two eyebolts.</p>	
5	Worker A: Remove the four bolts while supporting the robot to prevent it from tipping over.	
6	Worker B: Operate the crane and move the robot to the mounting location.	
7	<p>Worker B: Put the robot down in the mounting location.</p> <p>Worker A: Temporarily secure the robot base with four bolts.</p>	
8	Secure the robot according to the instructions in Mounting the Robot on page 26.	
9	Remove the eyebolts from the robot.	 <p>WARNING: Before running the robot, be sure to remove the eyebolts. Otherwise, the robot arm will strike these eyebolts.</p>

3.5 Mounting the Robot

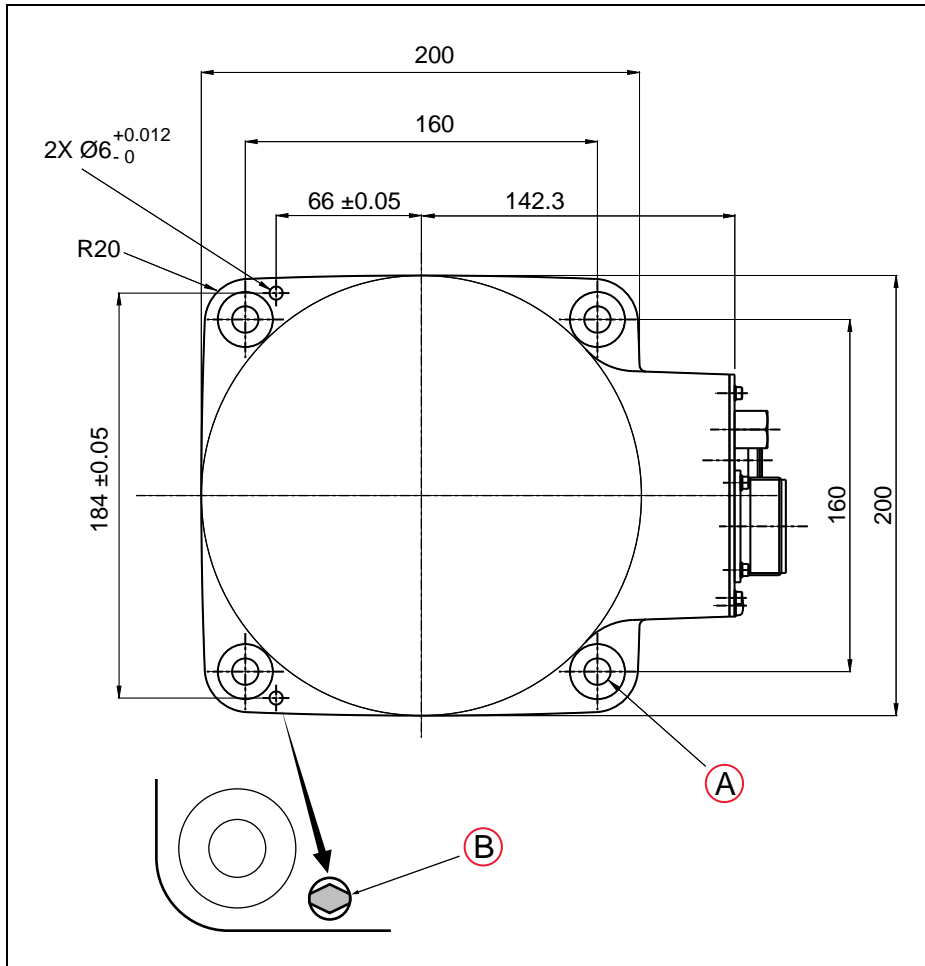

Figure 3-3. Mounting Hole Pattern for Robot. Units are mm.

Key	Meaning
A	4x Ø12 for Thru, or tap for M10
B	Diamond-shaped pin

- See the preceding figure for the location and dimensions of the robot mounting holes.
 - Drill four bolt holes (M10), 20 mm deep or more.
 - These either need to be tapped for M10, or you can drill 12 mm thru-holes, and use nuts on the other side of the mounting surface.
 - Drill a dowel pin hole Ø4 mm, H7 for the diamond-shaped pin, 10 mm deep or more.

NOTE: The diamond-shaped pin has a Ø6 mm diamond-shaped section, but the shank is only Ø4 mm. The hole in the base of the Viper is Ø6, but you need to drill a Ø4 hole in your mounting surface for the shank of that pin.

- Drill a dowel pin hole $\text{Ø}6$ mm, H7 for the internally threaded positioning pin, 10 to 15 mm deep.
2. Locate two alignment pins, one round and one diamond-shaped, supplied as part of the robot bundle.
 3. Drive the diamond-shaped pin into one $\text{Ø}6$, H7 hole in the robot base so that it is oriented as shown in the preceding figure.
 4. Drive the internally threaded alignment pin into the other $\text{Ø}6$, H7 hole in the robot base.

NOTE: Be sure to use the alignment pins. It can minimize positional deviations that may be caused by the removal/installation of the robot for maintenance and reduce vibration during operation.

5. Set the robot into place on the robot mount. When transporting the robot, follow the instructions given in Transporting the Robot on page 23.
6. Secure the robot to the mount with four bolts:
 - Bolt: M10, strength class: 12.9
 - Tightening torque: 70 ± 14 N·m (52 ± 10 ft-lbf)

For threaded M10 holes, use plain washers and 30 mm M10 bolts.

For 12 mm thru holes, use plain and lock washers on both sides.

3.6 Grounding the Robot

Ground the grounding terminal of the robot with a wire of 12 AWG or larger. Ground resistance must be less than 10 Ohms. See Grounding the Robot System on page 77.

3.7 Mounting the Front Panel

The Front Panel must be installed outside of the workspace.

NOTE: European standards require that the remote High Power push-button be located outside of the workspace of the robot.

3.8 Description of Connectors on Robot Interface Panel

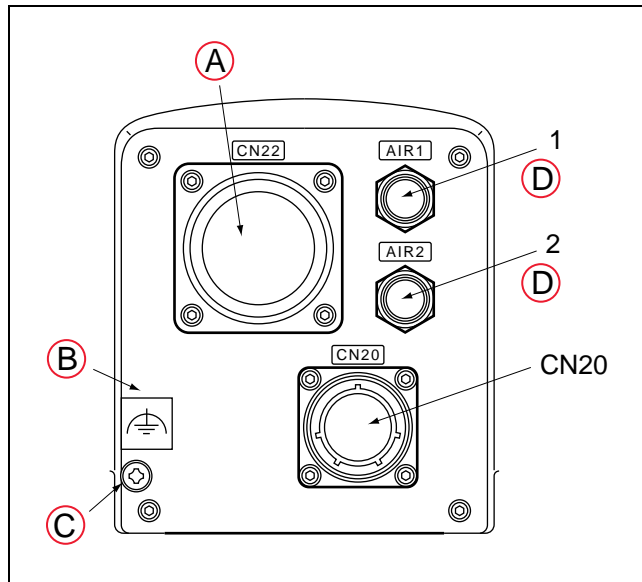

Figure 3-4. Robot Interface Panel

Key	Meaning	Key	Meaning
A	CN22 Power/Signal Cable to eMB-40/60R	C	Grounding Terminal, M5
B	Ground Label	D	Air 1 and Air 2

Table 3-2. Robot Interface Connections

CN22	The Arm Power/Signal cable from the eMB-40/60R is installed at this connector.
CN20	Pins 1 to 10 are wired directly to corresponding pins 1 to 10 on CN21 on the upper arm. Pins 12 to 18 are for solenoid control. See Air Lines and Signal Wiring on page 28.
AIR 1	Air line connector (BSPT1/4) for three solenoids in robot. Air Lines and Signal Wiring on page 28.
AIR 2	Air line connector (BSPT1/4), connects directly to AIR 2 on the second (upper) arm.
Grounding Terminal	Protective earth ground point on the robot. See Grounding the Robot on page 27.

3.9 Air Lines and Signal Wiring

The robot is equipped with seven air lines. Six lines, from AIR1 input, are controlled by the three internal solenoid valves. One line, from AIR2 input, is connected directly to AIR2 on the second arm. There are ten user electric lines. See the following figures and tables.

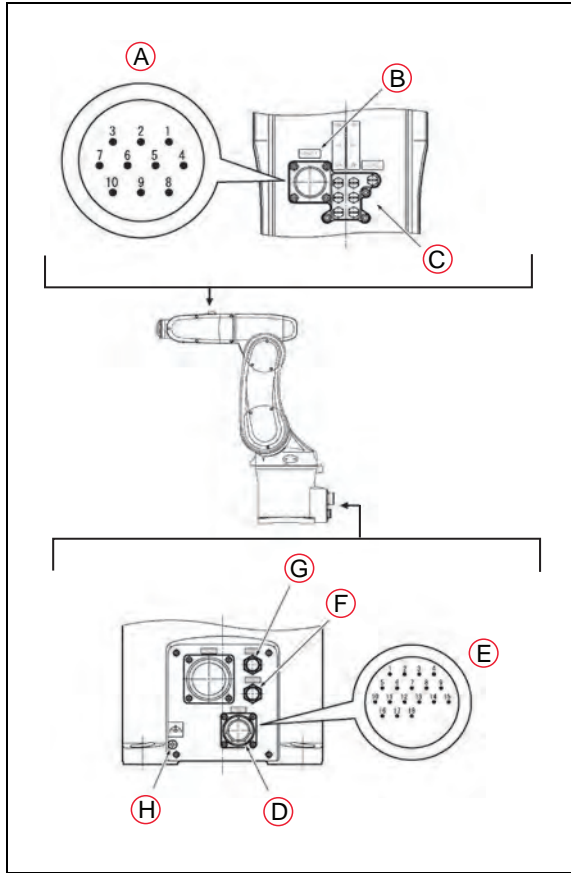

Note 1: Pins #1 to #10 on CN21 and those on CN20 are connected with each other. The allowable current per line is 1 A.

Note 2: Use the supplied mating connector sets for CN20 and CN21. See Cleanroom Option on page 133 for information about the mating connectors on Cleanroom and IP54/65 robots.

Key	Meaning
A	CN21 pin layout
B	Connector CN21
C	Air lines (x7)
D	Connector CN20
E	CN20 pin layout
F	AIR1 (BSPT ¼) - Air line
G	AIR2 (BSPT ¼) - Air line
H	Ground terminal, M5

Air intake/Exhaust States.



Air tubing joint		Valve Signal			
AIR1	Air intake	Exhaust	Solenoid valve	Solenoid	
				A	B
	1A	1B	1	ON	OFF
	1B	1A	1	OFF	ON
	2A	2B	2	ON	OFF
	2B	2A	2	OFF	ON
	3A	3B	3	ON	OFF
3B	3A	3	OFF	ON	
AIR2					

CN20 Pin Assignments
NPN type (source IN, sink OUT)

CN20 pin No.	Used for:
12	0 V
13	Solenoid 1A (solenoid valve 1)
14	Solenoid 1B (solenoid valve 1)
15	Solenoid 2A (solenoid valve 2)
16	Solenoid 2B (solenoid valve 2)
17	Solenoid 3A (solenoid valve 3)
18	Solenoid 3B (solenoid valve 3)

NPN type (source IN, sink OUT)

CN20 pin No.	Used for:
12	0 V
13	Solenoid 1A (solenoid valve 1)
14	Solenoid 1B (solenoid valve 1)
15	Solenoid 2A (solenoid valve 2)
16	Solenoid 2B (solenoid valve 2)
17	Solenoid 3A (solenoid valve 3)
18	Solenoid 3B (solenoid valve 3)

Connector set part No.	Connector No.	Model and part name	Appearance
05019-000	for CN20	SRCN6A25-24S (round type connector) Japan Aviation Electronics Industry Ltd.	
	for CN21	JMLP1610M (L type plug connector) DDK Electronics, Inc.	

Optional Solenoid Cable

An optional 4 meter solenoid cable is available that connects between the XDIO connector on the SmartController and the CN20 connector on the robot. The part number is 05739-040.

NOTE: The optional solenoid cable does not work with the IP54/65 or the Clean-room robots.

Installing this cable allows you to control the three internal robot solenoids directly from either the ACE software, using the digital outputs, or programmatically, with eV+. Refer to the following screen shots:

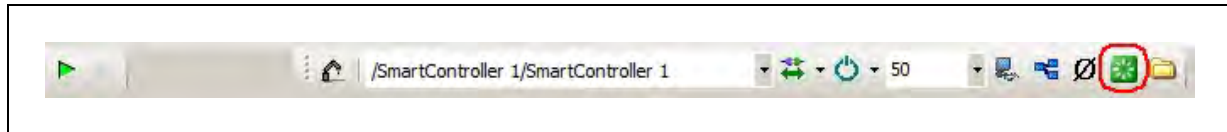

Figure 3-5. ACE Digital I/O Icon

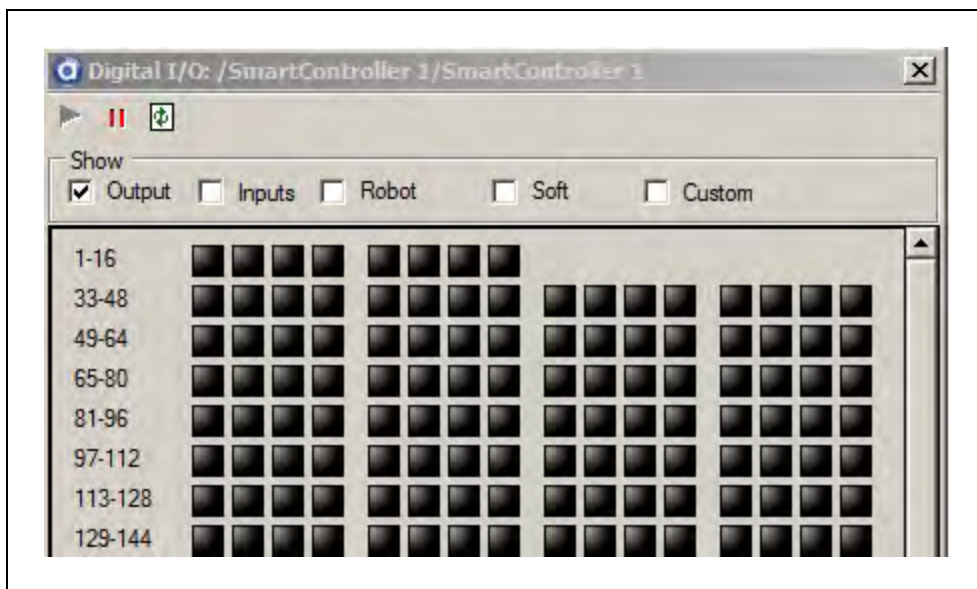

Figure 3-6. ACE Digital I/O Box (Output Shown)

See the following section for the details on activating the individual ports on each solenoid.

Table 3-3. Viper Solenoid Control

	Active Output Port	Signal States ¹	
Solenoid 1	A	0001	-0002
	B	-0001	0002
Solenoid 2	A	0003	-0004
	B	-0003	0004
Solenoid 3	A	0005	-0006
	B	-0005	0006
¹ The two-position, double solenoids require both signal states to be activated. Invalid states will result in indeterminate outputs.			

In addition to controlling the internal robot solenoids, the Solenoid cable brings a portion of the other XDIO signals out to the CN21 connector at the top of the robot. See the following table for details of which signals are available at CN21. See the SmartController EX User's Guide's for the electrical specifications for the signals from the XDIO connector.

Table 3-4. CN21 Signal List When Using Solenoid Cable

CN21 Pin #	Signal from XDIO on SmartController	CN21 Pin #	Signal from XDIO on SmartController
1	Input 1001 ^a	6	Not connected
2	Input 1002 ^a	7	Output 0007 ^b
3	Input 1003 ^a	8	Output 0008 ^b
4	Input 1004 ^a	9	24 V Output ^c
5	Input 1005 ^a	10	Ground
^a Inputs 1001 to 1005 are preconfigured as low-active (sinking) inputs. ^b Outputs 0007 and 0008 are preconfigured as high-side (sourcing) outputs. ^c Limited to a combined total of 1A of current.			

Solenoid Valve Specifications

Table 3-5. Solenoid Valve Specifications

	Item	Specifications
Valve	Switching system	2-position double
	Applicable fluid	Air
	Operating system	Pilot type
	Effective cross section (Cv value)	1.2 mm ²
	Lubrication	Oilless
	Operating pressure range	0.1 to 0.7 MPa (14 to 101 psi) ^a
	Response time	15 ms or less at 0.5 MPa (72.5 psi)
	Maximum operating frequency	10 Hz
	Ambient temperature	-5 to 50° C (Dry air, non-condensing)
Solenoid	Operating voltage	24 V ±10%
	Power consumption (current)	0.5 W (21 mA)
	Surge voltage protection circuit	Zener diode
^a Note that the robot is rated at 0.1 to 0.39 MPa, 0.49 Max (14 - 56.6 psi, 71.1 Max). This upper limit is lower than the solenoid's upper limit.		

External Mounting Locations on Robot

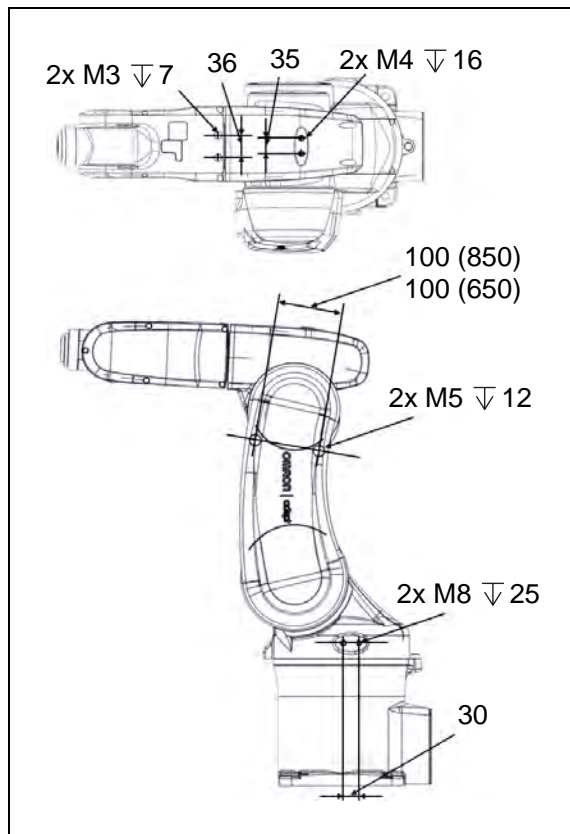

Figure 3-7. External Mounting Holes on Robot. Units are mm.

3.10 Designing End-Effectors

Design an end-effector such that it is in compliance with items described in this section.



CAUTION: If the end-effector design precautions are not observed, the clamped parts of the robot may become loose, rattle, or be out of position. The mechanical parts of the robot and robot controller may become damaged.

Continuous Turn on J6

As an option, the Viper 650/850 can be ordered so that Joint 6 (J6) is programmed for continuous turn. Note that if J6 is programmed for continuous turn, it may lose its calibration. However, the other robot joints (J1 - J5) will not be affected.

Mass of End-Effector

Design the end-effector so that the total mass of the end-effector (including workpiece) will be lighter than the maximum payload capacity of the robot (5 kg). The total mass includes the wiring, tubing, etc.

Center of Gravity Position of End-Effector

Design an end-effector so that the center of gravity of the end-effector (including workpiece) is within the range shown in the following figure.

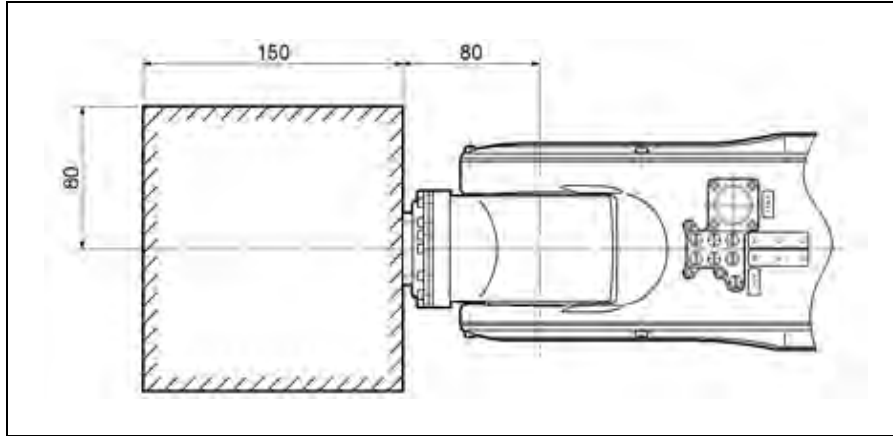

Figure 3-8. Allowable Range of Center of Gravity of End-effector. Units are mm.

Moment of Inertia Around J4, J5, and J6

Design an end-effector so that its moments of inertia around J4, J5, and J6 (including mass of workpiece) do not exceed the maximum allowable moments of inertia of the robot.

- Maximum allowable moment of inertia around J4 and J5: 0.295 kgm²
- Maximum allowable moment of inertia around J6: 0.045 kgm²

When calculating the moment of inertia around J4, J5, and J6 of the end-effector, use the formulas given in the following table. See Robot Installation on page 21.

Table 3-6. Moment of Inertia Formulas

<p>(A)</p>	<p>(B)</p> $I = \frac{mr^2}{2}$	<p>(G)</p>	<p>(H)</p> $I = \frac{2mr^2}{5}$
<p>(C)</p>	<p>(D)</p> $I = \frac{m}{4} \left(r^2 + \frac{l^2}{3} \right)$	<p>(J)</p>	<p>(K)</p> $I = I_c + ml^2$
<p>(E)</p>	<p>(F)</p> $I = \frac{m}{12} (b^2 + c^2)$		

Key	Meaning
A	Cylinder 1
B	Axis of rotation = Center axis
C	Cylinder 2
D	Axis of rotation passes through the center of gravity
E	Rectangular Parallelepiped
F	Axis of rotation passes through the center of gravity
G	Sphere
H	Axis of rotation = Center axis
J	Center of gravity not on the axis of rotation
K	I_g : Inertia moment around center of gravity (kgm^2)
	I = Moment of inertia (kgm^2)
	m = Mass (kg)
	r = Radius (m)
	b, c, ℓ = Length (m)

Calculation Example

When calculating the moment of inertia of a complicated shape, divide the shape into simple parts as much as possible for easier calculations.

The following diagrams and tables use an example end-effector shape to demonstrate how to calculate the moment of inertia.

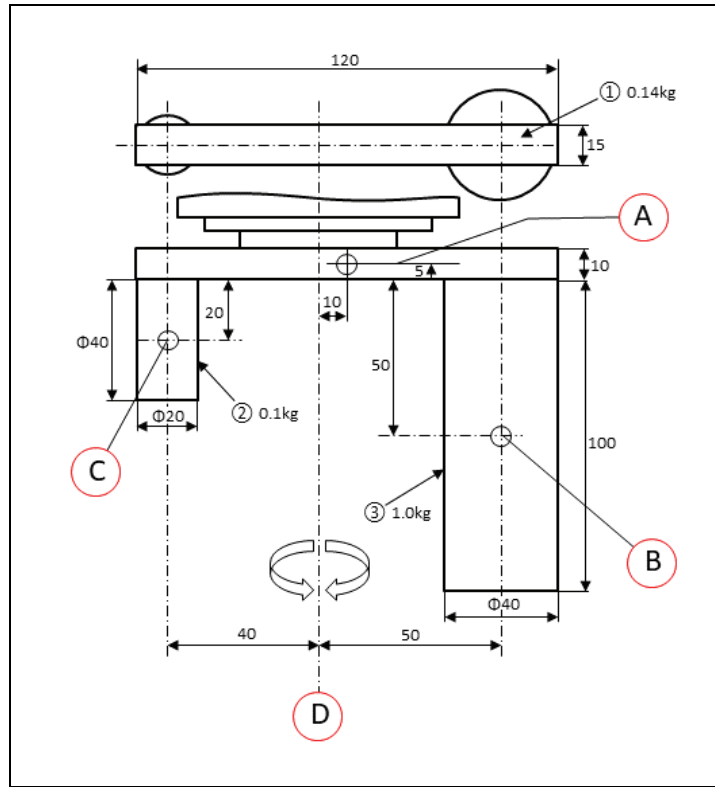

Figure 3-9. Moment of Inertia Around J6

Key	Meaning	Key	Meaning
Moment of Inertia around J6			
A	Center of gravity of ①	C	Center of gravity of ③
B	Center of gravity of ②	D	Rotation around J6

- Moment of inertia around J6 of ①: I_1 (from 3 and 5 in previous table)

$$I_1 = \frac{0.14}{12} (0.12^2 + 0.015^2) + 0.14 \times 0.01^2$$

$$= 1.85 \times 10^{-4} \text{ [kgm}^2\text{]}$$

- Moment of inertia around J6 of ②: I_2 (from 1 and 5 in previous table)

$$I_2 = \frac{0.1 \times 0.01^2}{2} + 0.1 \times 0.04^2$$

$$= 1.65 \times 10^{-4} \text{ [kgm}^2\text{]}$$

- Moment of inertia around J6 of ③: I_3 (from 1 and 5 in previous table)

$$I_3 = \frac{1.0 \times 0.02^2}{2} + 1.0 \times 0.05^2$$

$$= 2.7 \times 10^{-3} \text{ [kgm}^2\text{]}$$

- Moment of inertia around J6 of entire end-effector: I_{J6}

$$I_{J6} = I_1 + I_2 + I_3 = 0.003 \text{ [kgm}^2\text{]}$$

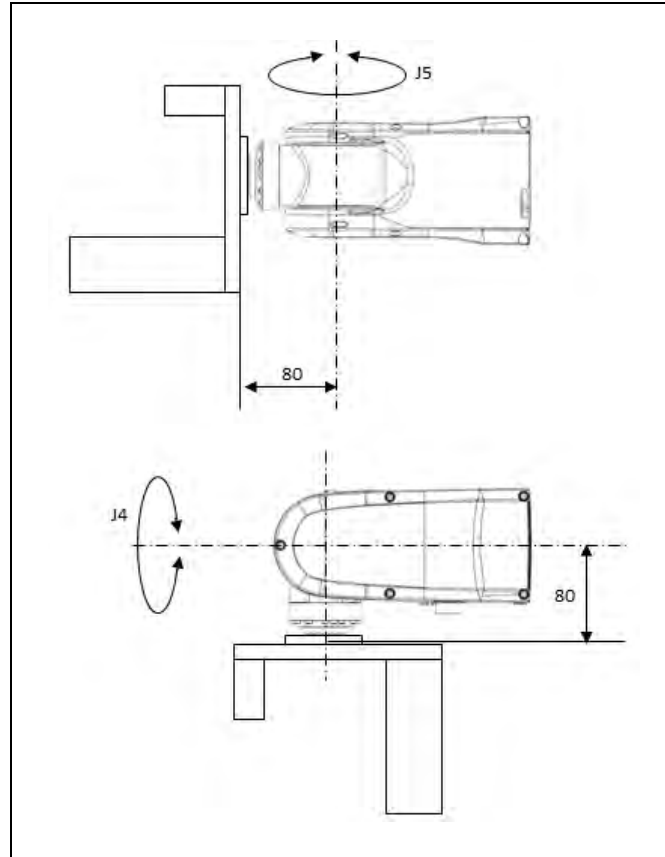

Figure 3-10. Moment of Inertia Around J4 and J5

For the end effector shown above, the moment of inertia around J4 and J5 can be calculated according to the same formula.

- Moment of inertia around J4 and J5 of ①: I_1 (from 3 and 5 in previous table)

$$I_1 = \frac{0.14}{12} (0.015^2 + 0.01^2) + 0.14 \times ((0.08 + 0.005)^2 + 0.01^2) \\ = 1.03 \times 10^{-3} \text{ [kgm}^2\text{]}$$

- Moment of inertia around J4 and J5 of ②: I_2 (from 2 and 5 in previous table)

$$I_2 = \frac{0.1}{4} \left(0.01^2 + \frac{0.04^2}{3} \right) + 0.1 \times ((0.08 + 0.01 + 0.02)^2 + 0.04^2) \\ = 1.39 \times 10^{-3} \text{ [kgm}^2\text{]}$$

- Moment of inertia around J4 and J5 of ③: I_3 (from 2 and 5 in previous table)

$$I_3 = \frac{1.0}{4} \left(0.02^2 + \frac{0.1^2}{3} \right) + 1.0 \times ((0.08 + 0.01 + 0.05)^2 + 0.05^2) \\ = 2.30 \times 10^{-3} \text{ [kgm}^2\text{]}$$

- Moment of inertia around J4 and J5 of entire end-effector: $I_{J4} I_{J5}$

$$I_{J4} = I_{J5} = I_1 + I_2 + I_3 = 2.54 \times 10^{-2} \text{ [kgm}^2\text{]}$$

Chapter 4: eMotionBlox-40/60R

4.1 Introduction

The eMotionBlox-40/60R (eMB-40/60R) is a distributed servo controller and amplifier. It is designed with a dedicated digital signal processor to communicate, coordinate, and execute servo commands. It is the platform on which the eV+ operating system runs.

NOTE: The eMB-40/60R has in previous manuals been referred to as both an eMB-60R and an eMB-40R. They are, in fact, the same exact component.

The eMB-40/60R consists of:

- a distributed servo amplifier
- a RISC processor for servo loop control
- a node on the IEEE 1394 network
- a power controller that uses single-phase AC power, 200-240 Volts
- a status panel with 2-digit alpha-numeric display to show operating status and fault codes

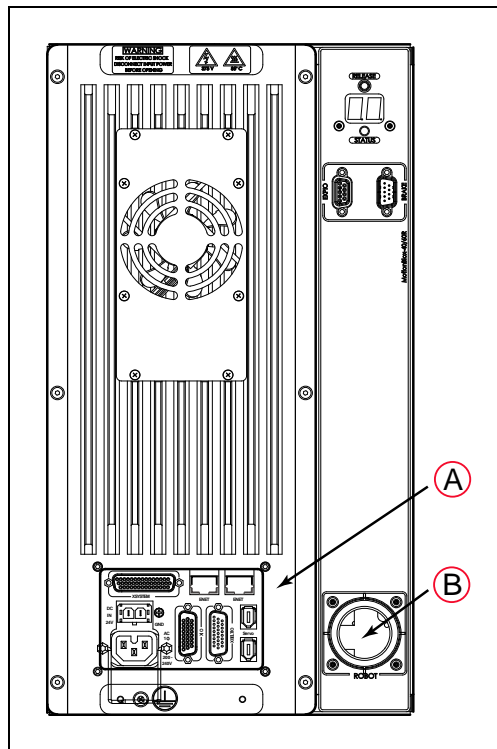

Figure 4-1. (A) Robot Interface Panel and (B) Robot Connector on eMB-40/60R

4.2 Connectors on eMB-40/60R Interface Panel

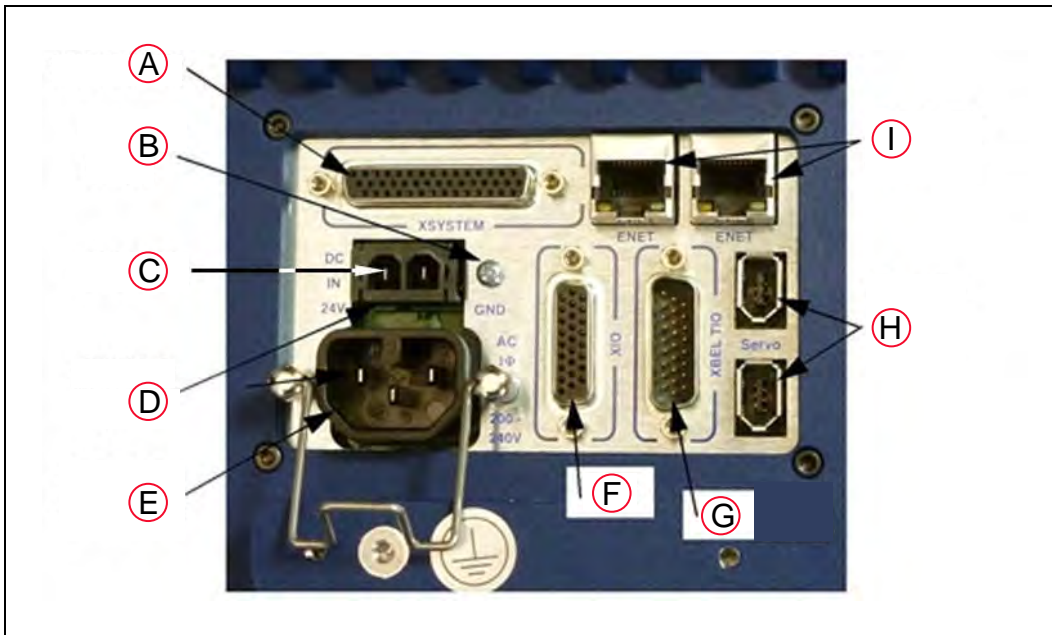

Figure 4-2. eMB-40/60R Interface Panel

Key	Name	Meaning
A	XSYSTEM	Connects to the eAIB XSYSTEM cable or the eAIB XSYS cable (for SmartController EX).
B	Ground Point	For cable shield from user-supplied 24 VDC cable.
C	+24 V Pin	+24 V pin of the 24 VDC connector.
D	24 VDC	For user-supplied 24 VDC power. The mating connector is provided.
E	200/240 VAC	For 200-240 VAC, single-phase, input power. The mating connector is provided.
F	XIO	For user I/O signals for peripheral devices. Provides 8 outputs and 12 inputs. See eMotionBlox-40/60R on page 39 for connector pin allocations for inputs and outputs. That section also contains details on how to access these I/O signals. (DB-26, high density, female)
G	XBELTIO	Adds two belt encoders, Force or EXPPIO, and an RS-232 interface, which is reserved for future use.
H	Smart-Servo	For the IEEE 1394 cable from the controller.
I	ENET	Two Ethernet ports are available. One will be needed to connect to a PC running ACE software.

Table 4-1. Connectors on the eMB-40/60R Interface Panels

24 VDC	For connecting user-supplied 24 VDC power. The mating connector is provided.
Ground Point	For connecting cable shield from user-supplied 24 VDC cable.
200/240 VAC	For connecting 200-240 VAC, single-phase, input power. The mating connector is provided.
SmartServo	For connecting the IEEE 1394 cable from the controller SmartServo to a SmartServo on the eMB-40/60R.
XIO	For user I/O signals for peripheral devices. This connector provides 8 outputs and 12 inputs. See Connecting Digital I/O to the System on page 45 for connector pin allocations for inputs and outputs. That section also contains details on how to access these I/O signals. (DB-26, high density, female)
XSYSTEM	Includes the functions of the XPANEL and XSLV on the legacy MB-40/60R. Connects to the controller XSYS connector. This requires either an eAIB XSLV Adapter cable to connect to the XSYS cable, or an eAIB XSYS cable (HDB44-to-DB9, male), which replaces the XSYS cable.
ENET	Reserved for future use.
XBELTIO	Adds two belt encoders, EXPIO, and an RS-232 interface (which is reserved for future use).

4.3 eMB-40/60R Operation

Status LED

The Status LED Indicator is located near the top of the eMB-40/60R. See the following figure. This is a bi-color, red and green LED. The color and blinking pattern indicates the status of the robot. See the following table.

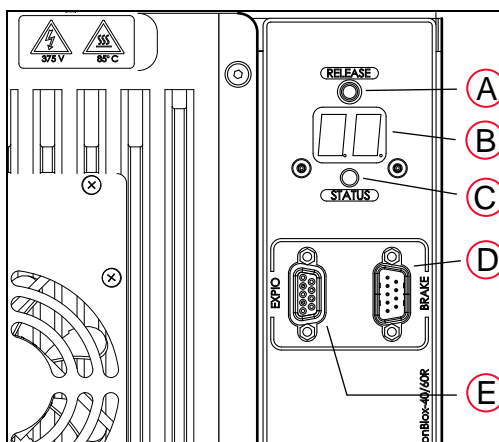

Figure 4-3. Controls and Indicators on eMB-40/60R

Key	Meaning	Key	Meaning
A	Brake Release Button	D	Brake Connector
B	Status Panel Display	E	EXPIO Connector
C	Status LED Indicator		

Table 4-2. Status LED Definition

LED Status	Description
Off	24 VDC not present
Green, Slow Blink	High Power Disabled
Green, Fast Blink	High Power Enabled
Green/Red Blink	Selected Configuration Node
Red, Fast Blink	Fault - refer to the following table
Solid Green or Red	Initialization or Robot Fault

Status Panel

The status panel, shown in the preceding figure, displays alpha-numeric codes that indicate the operating status of the eMB-40/60R. These codes provide details for quickly isolating problems during troubleshooting.

In the Status Panel Codes table, the '#' in the LED column represents a single digit. The digits will be displayed as one of the following:

0	1	2	3	4	5	6	7	8	9
0	1	2	3	4	5	6	7	8	9

Table 4-3. Status Panel Codes

LED	Text	Status Code	LED	Text	Status Code
OK	OK	No Fault	h#	h#	High Temp Amp (Joint #)
ON	ON	High Power ON Status	H#	H#	High Temp Encoder (Joint #)
MA	MA	Manual Mode	HV	HV	High Voltage Bus Fault
24	24	24 V Supply Fault	I#	I#	Initialization Stage (Step #)
A#	A#	Amp Fault (Joint #)	M#	M#	Motor Stalled (Joint #)
AC	AC	AC Power Fault	P#	P#	Power System Fault (Code #)
BA	BA	Backup Battery Low Voltage	PR	PR	Processor Overloaded
B#	B#	IO Blox Fault (Address #)	RC	RC	RSC Fault
D#	D#	Duty Cycle Exceeded (Joint #)	S#	S#	Safety System Fault (Code #)
E#	E#	Encoder Fault (Joint #)	SE	SE	E-Stop Delay Fault
ES	ES	E-Stop	SW	SW	Watchdog Timeout
F#	F#	External Sensor Stop	T#	T#	Safety System Fault (Code 10 + #)
FM	FM	Firmware Mismatch	TR	TR	Teach Restrict Fault
FW	FW	1394 Fault	V#	V#	Hard Envelope Error (Joint #)

NOTE: Due to the nature of the Viper 650/850 robot's bus line encoder wiring, a single encoder wiring error may result in multiple channels of displayed encoder errors. Reference the lowest encoder number displayed.

Brake Release Button

A Brake Release button is located at the top right of the eMB-40/60R. See Controls and Indicators on eMB-40/60R on page 41. When pressed, the button will disable High Power and display "BK" on the eMB-40/60R, but no brakes will be released.

NOTE: If this button is pressed while high power is on, high power will automatically shut down.

For manual release of the brakes on the Viper 650/850 robot, a Brake Release connector is provided on the eMB-40/60R for connecting a manual brake release box. See the following section for more details. Also, an integrated brake release switch is provided on UL robots. See Brakes on page 91.

Brake Release Connector

The 9-pin Brake Release connector provides an interface for connecting a manual brake release box.

Table 4-4. Brake Release Connector Pinouts

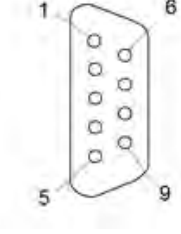
Pin #	Description	Pin Location
1	Release1_N	 <p>DB-9 Female Brake Connector</p>
2	Release2_N	
3	Release3_N	
4	Release4_N	
5	Release5_N	
6	Release6_N	
7	GND	
8	Not connected	
9	24 V	
Mating Connector: D-Subminiature 9-Pin Male		

4.4 Connecting Digital I/O to the System

You can connect digital I/O to the system in several different ways. See the following table and figure.

NOTE: A typical IO Blox configuration is shown in Figure 4-4. Other configurations may be possible. Contact your local Omron support for more information.

Table 4-5. Digital I/O Connection Options

Product	I/O Capacity	For more details
XIO Connector on eMB-40/60R	12 inputs 8 outputs	see Using Digital I/O on eMB-40/60R XIO Connector on page 46
XDIO Connector on optional SmartController EX	12 inputs 8 outputs	see <i>SmartController EX User's Guide</i>
Optional IO Blox Devices, connect to EXPPIO connector on the eMB-40/60R	8 inputs, 8 outputs per device; up to four IO Blox devices per system	see <i>IO Blox User's Guide</i>

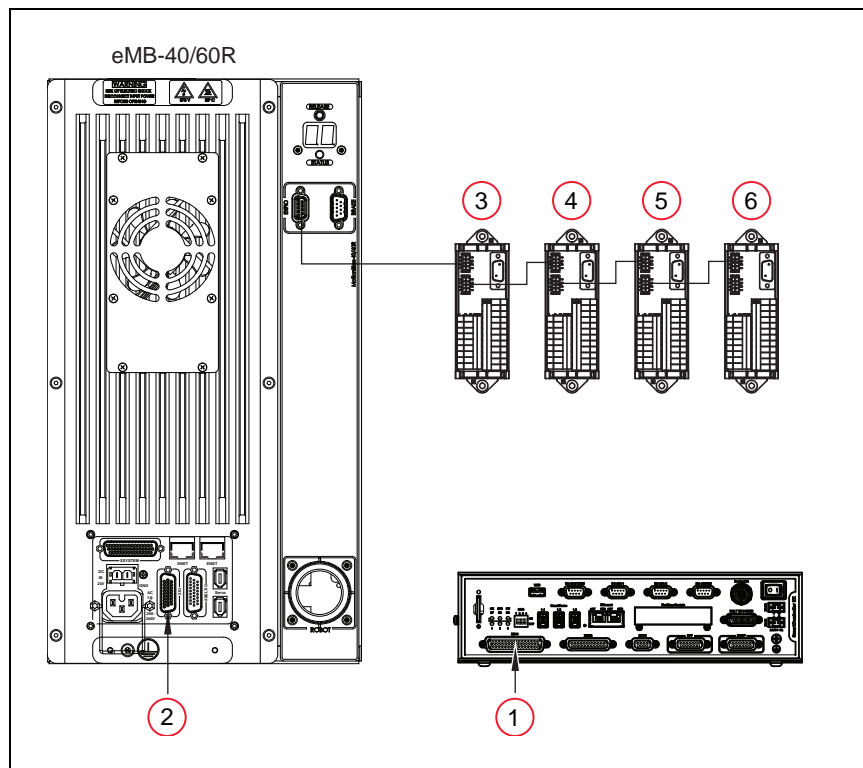

Figure 4-4. Connecting Digital I/O to the System

Table 4-6. Digital I/O Signal Ranges

Item	Description	Type	Signal Range
1	SmartController XDIO connector	Inputs	1001 - 1012
		Outputs	0001 - 0008
2	eMB-40/60R XIO connector	Inputs	1097 - 1108
		Outputs	0097 - 0104
3	IO Blox 1	Inputs	1113 - 1120
		Outputs	0105 - 0112
4	IO Blox 2	Inputs	1121 - 1128
		Outputs	0113 - 0120
5	IO Blox 3	Inputs	1129 - 1136
		Outputs	0121 - 0128
6	IO Blox 4	Inputs	1137 - 1144
		Outputs	0129 - 0136

4.5 Using Digital I/O on eMB-40/60R XIO Connector

The XIO connector on the eMB-40/60R interface panel offers access to digital I/O, 12 inputs and 8 outputs. These signals can be used by eV+ to perform various functions in the workcell. See the following table for the XIO signal designations.

- 12 Inputs, signals 1097 to 1108
- 8 Outputs, signals 0097 to 0104

Table 4-7. XIO Signal Designations

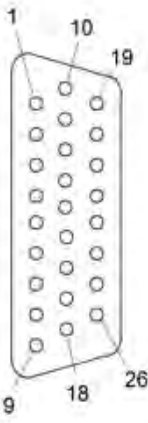
Pin No.	Designation	Signal Bank	eV+ Signal Number	Pin Locations
1	GND			 <p>XIO 26-pin female connector on eMB-40/60R Interface Panel</p>
2	24 VDC			
3	Common 1	1		
4	Input 1.1	1	1097	
5	Input 2.1	1	1098	
6	Input 3.1	1	1099	
7	Input 4.1	1	1100	
8	Input 5.1	1	1101	
9	Input 6.1	1	1102	
10	GND			
11	24 VDC			
12	Common 2	2		
13	Input 1.2	2	1103	
14	Input 2.2	2	1104	
15	Input 3.2	2	1105	
16	Input 4.2	2	1106	
17	Input 5.2	2	1107	
18	Input 6.2	2	1108	
19	Output 1		0097	
20	Output 2		0098	
21	Output 3		0099	
22	Output 4		0100	
23	Output 5		0101	
24	Output 6		0102	
25	Output 7		0103	
26	Output 8		0104	

Optional I/O Products

These optional products are also available for use with digital I/O:

- **XIO Breakout Cable**, 5 meters long, with flying leads on user's end. See XIO Breakout Cable on page 52 for information. This cable is not compatible with the XIO Termination Block mentioned below.
- **XIO Termination Block**, with terminals for user wiring, plus input and output status LEDs. Connects to the XIO connector with 6-foot cable. See the *XIO Termination Block Installation Guide* for details.

XIO Input Signals

The 12 input channels are arranged in two banks of six. Each bank is electrically isolated from the other bank and is optically isolated from the eMB-40/60R ground. The six inputs within each bank share a common source/sink line.

The inputs are accessed through direct connection to the XIO connector (see the following table), or through the optional XIO Termination Block. See the documentation supplied with the Termination Block for details.

The XIO inputs cannot be used for REACTI programming, high-speed interrupts, or vision triggers. Refer to the eV+ user guides on the corporate website.

XIO Input Specifications

Table 4-8. XIO Input Specifications

Parameter	Value
Operational voltage range	0 to 30 VDC
OFF state voltage range	0 to 3 VDC
ON state voltage range	10 to 30 VDC
Typical threshold voltage	$V_{in} = 8$ VDC
Operational current range	0 to 7.5 mA
OFF state current range	0 to 0.5 mA
ON state current range	2.5 to 6 mA
Typical threshold current	2.0 mA
Impedance (V_{in}/I_{in})	3.9 K Ω minimum
Current at $V_{in} = +24$ VDC	$I_{in} \leq 6$ mA
Turn on response time (hardware) Software scan rate/response time	5 μ sec maximum 16 ms scan cycle/ 32 ms max response time
Turn off response time (hardware) Software scan rate/response time	5 μ sec maximum 16 ms scan cycle/ 32 ms max response time

NOTE: The input current specifications are provided for reference. Voltage sources are typically used to drive the inputs.

Typical Input Wiring Example

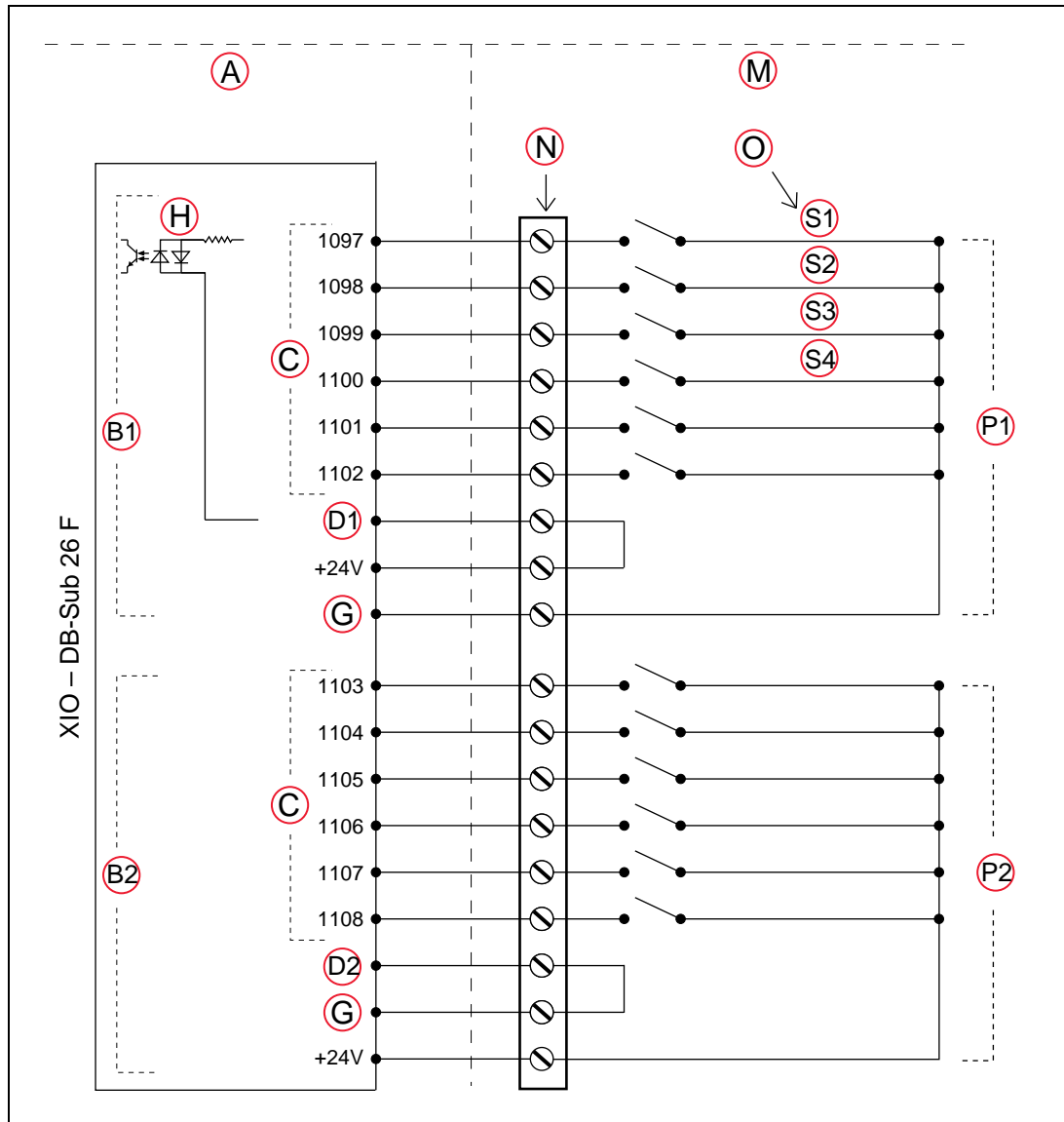

Figure 4-5. Typical User Wiring for XIO Input Signals

NOTE: The off-state current range exceeds the leakage current of XIO outputs. This guarantees that the inputs will not be turned on by the leakage current from the outputs. This is useful in situations where the outputs are looped-back to the inputs for monitoring purposes.

Key	Meaning
A	Supplied Equipment
B1	Input Bank 1
B2	Input Bank 2
C	Signals
D1	Bank 1 Common
D2	Bank 2 Common
G	Ground
H	(equivalent circuit)
M	User-Supplied Equipment
N	Wiring Terminal Block
O	Typical User Input Signals
P1	Bank 1 configured for Sinking (NPN) Inputs
P2	Bank 2 configured for Sourcing (PNP) Inputs
	Note: All Input signals can be used for either sinking or sourcing configurations.
S1	Part Present Sensor
S2	Feeder Empty Sensor
S3	Part Jammed Sensor
S4	Sealant Ready Sensor

XIO Output Signals

The eight digital outputs share a common, high-side (sourcing) Driver IC. The driver is designed to supply any kind of load with one side connected to ground. It is designed for a range of user-provided voltages from 10 to 24 VDC and each channel is capable of up to 0.7 A of current. This driver has overtemperature protection, current limiting, and shorted load protection. In the event of an output short or other overcurrent situation, the affected output of the Driver IC turns off and back on automatically to reduce the temperature of the IC. The Driver draws power from the primary 24 VDC input to the robot through a self-resetting polyfuse.

The outputs are accessed through direct connection to the XIO connector (see Table 4-7.), or through the optional XIO Termination Block. See the documentation supplied with the Termination Block for details.

XIO Output Specifications

Table 4-9. XIO Output Circuit Specifications

Parameter	Value
Power supply voltage range	See System Operation
Operational current range, per channel	$I_{out} \leq 700 \text{ mA}$
Total Current Limitation, all channels on	$I_{total} \leq 1.0 \text{ A @ } 50^\circ \text{ C ambient}$ $I_{total} \leq 1.5 \text{ A @ } 25^\circ \text{ C ambient}$
On-state resistance ($I_{out} = 0.5 \text{ A}$)	$R_{on} \leq 0.32 \Omega @ 85^\circ \text{ C}$
Output leakage current	$I_{out} \leq 25 \mu\text{A}$
Turn-on response time	125 μsec max., 80 μsec typical (hardware only)
Turn-off response time	60 μsec . max., 28 μsec typical (hardware only)
Output voltage at inductive load turnoff ($I_{out} = 0.5 \text{ A}$, Load = 1 mH)	$(+V - 65) \leq V_{demag} \leq (+V - 45)$
DC short circuit current limit	$0.7 \text{ A} \leq I_{LIM} \leq 2.5 \text{ A}$
Peak short circuit current	$I_{ovpk} \leq 4 \text{ A}$

Typical Output Wiring Example

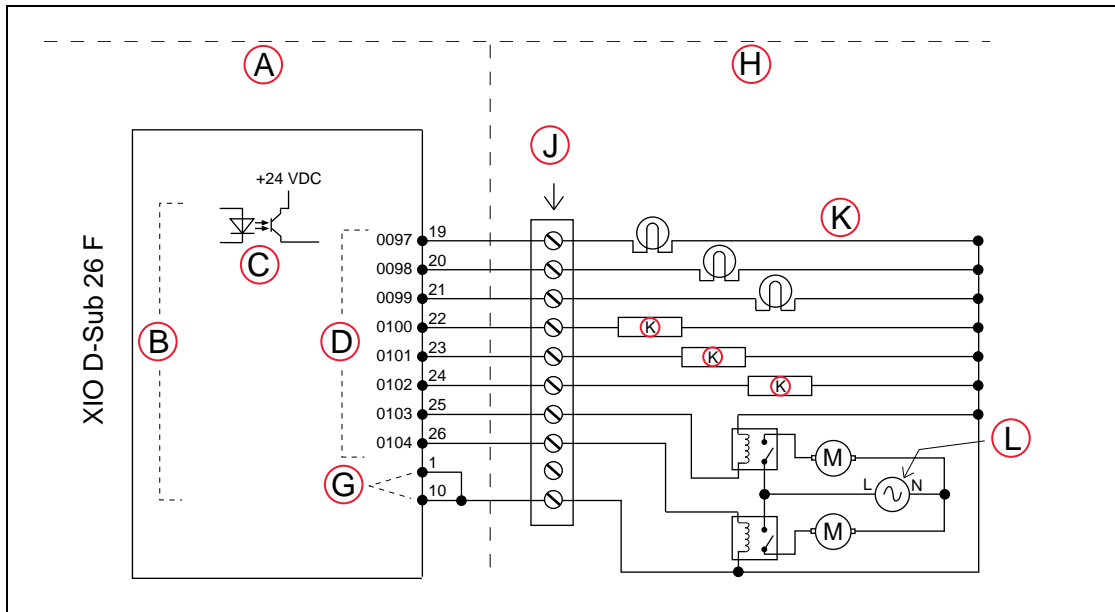

Figure 4-6. Typical User Wiring for XIO Output Signals

Key	Meaning	Key	Meaning
A	Supplied Equipment	H	User-Supplied Equipment
B	Outputs 1-8	J	Wiring Terminal Block
C	(equivalent circuit)	K	Typical User Loads
D	Signal	L	Customer AC Power 10 Supply
G	Ground	M	Motor (example of a load)

XIO Breakout Cable

The XIO Breakout cable is available as an option - see the following figure. This cable connects to the XIO connector on the eMB-40/60R, and provides flying leads on the user's end, for connecting input and output signals in the workcell. The part number for the cable is 04465-000, and the length is 5 M (16.4 ft).

See the following table for the wire chart on the cable.

NOTE: This cable is not compatible with the XIO Termination Block.



Figure 4-7. Optional XIO Breakout Cable

Table 4-10. XIO Breakout Cable Wire Chart

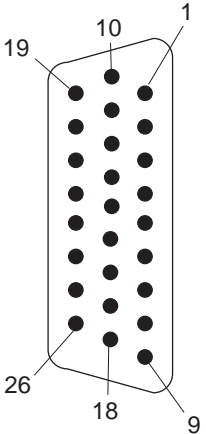
Pin No.	Signal Designation	Wire Color	Pin Locations
1	GND	White	 <p>26-pin male connector on XIO Breakout Cable</p>
2	24 VDC	White/Black	
3	Common 1	Red	
4	Input 1.1	Red/Black	
5	Input 2.1	Yellow	
6	Input 3.1	Yellow/Black	
7	Input 4.1	Green	
8	Input 5.1	Green/Black	
9	Input 6.1	Blue	
10	GND	Blue/White	
11	24 VDC	Brown	
12	Common 2	Brown/White	
13	Input 1.2	Orange	
14	Input 2.2	Orange/Black	
15	Input 3.2	Gray	
16	Input 4.2	Gray/Black	
17	Input 5.2	Violet	
18	Input 6.2	Violet/White	
19	Output 1	Pink	
20	Output 2	Pink/Black	
21	Output 3	Light Blue	
22	Output 4	Light Blue/Black	
23	Output 5	Light Green	
24	Output 6	Light Green/Black	
25	Output 7	White/Red	
26	Output 8	White/Blue	
Shell		Shield	

4.6 Mounting the eMB-40/60R

Dimensions and Mounting Holes

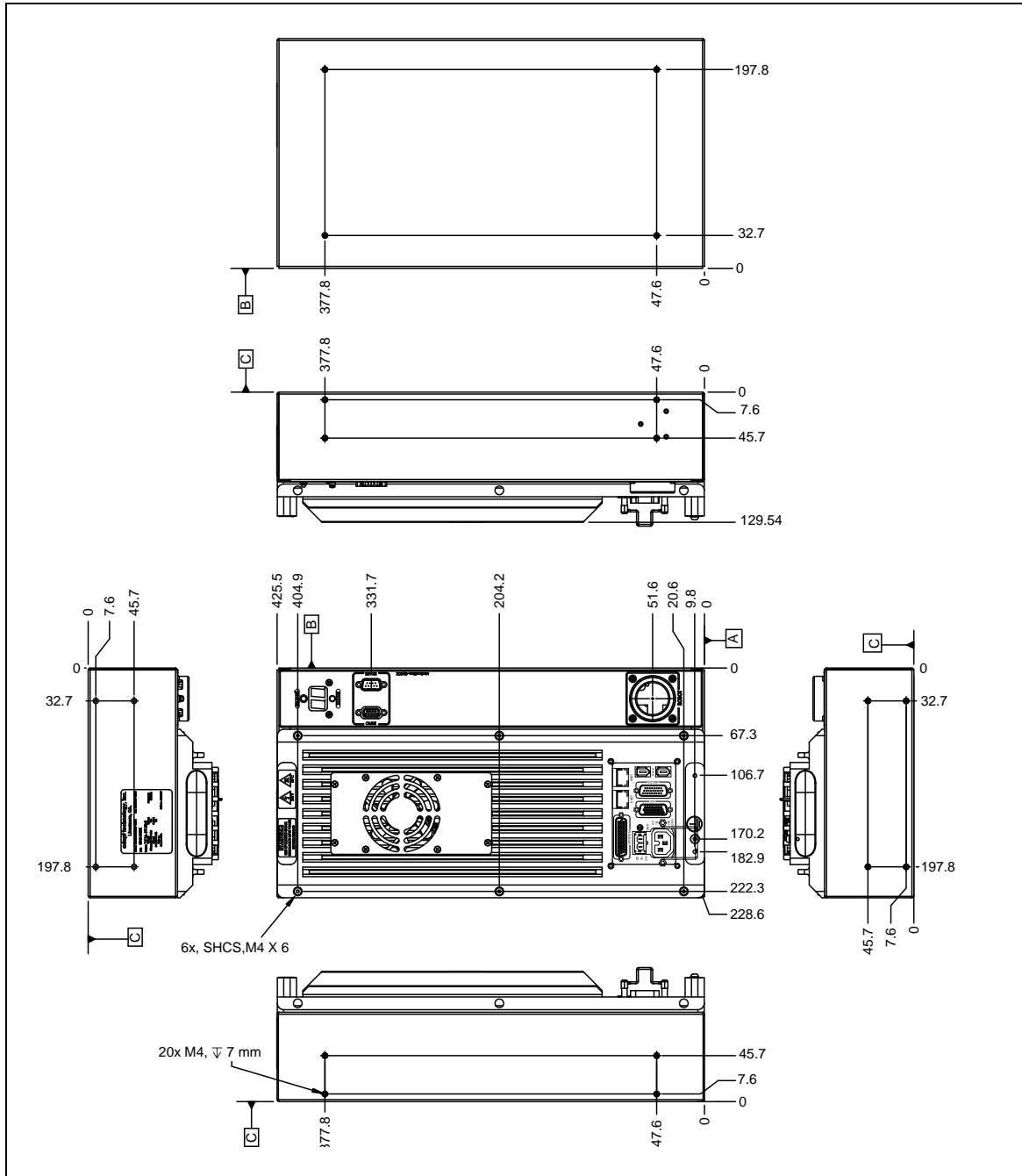

Figure 4-8. eMB-40/60R Mounting Dimensions. Units are mm.

NOTE: 112 mm clearance required in front of unit to remove amps from box enclosure.

Mounting Clearances

NOTE: The mounting of the eMB-40/60R and all terminations at the eMB-40/60R must be performed in accordance with all local and national standards.

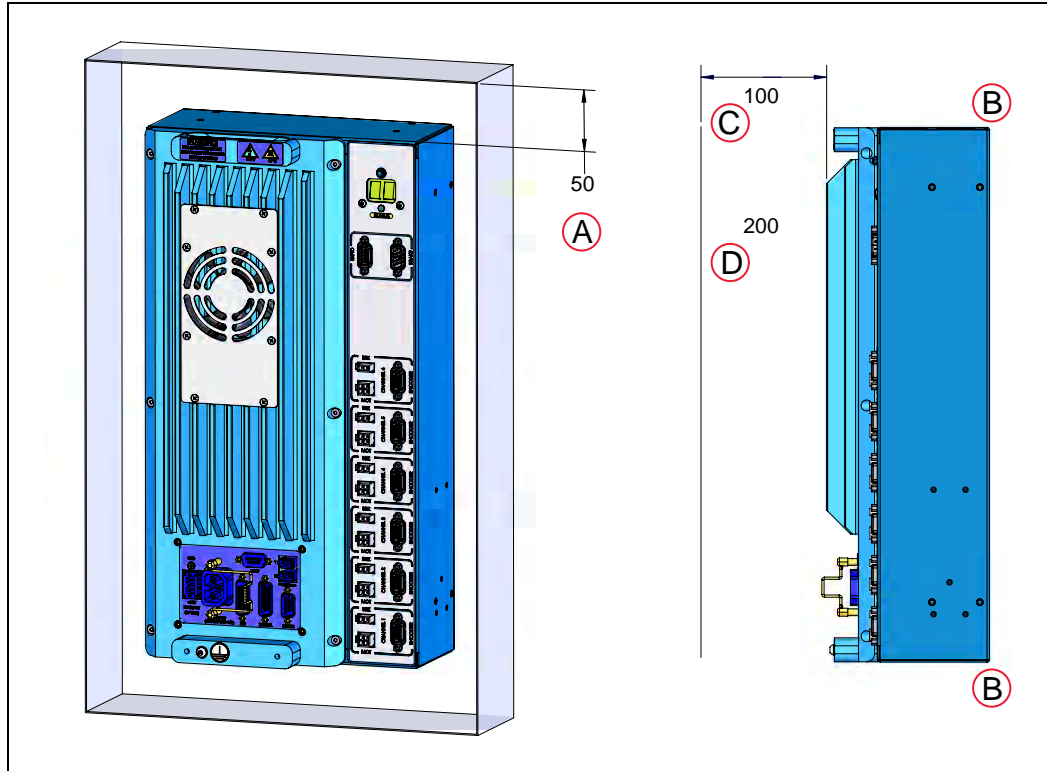

Figure 4-9. Clearance for the eMB-40/60R. Units are mm.

Surface	Air Gap
(A) Sides	50 mm (2 inches)
(B) Back	0 mm
The following two dimensions are from the front of the heat sink.	
(C) Front, when wall-mounted	100 mm (4 inches)
(D) Front, when flat-mounted	200 mm (8 inches)

NOTE: These dimensions assume the eMB-40/60R has exposure to outside air, rather than being in a sealed container. Any sealed container would need to provide sufficient cooling for the eMB-40/60R's internal fan to be effective.

Chapter 5: System Installation

5.1 System Cables, without SmartController EX

The letters in the following figure correspond to the letters in the table of cables and parts. The numbers correspond to the steps in the cable installation overview table. The tables are on the pages following the figure.

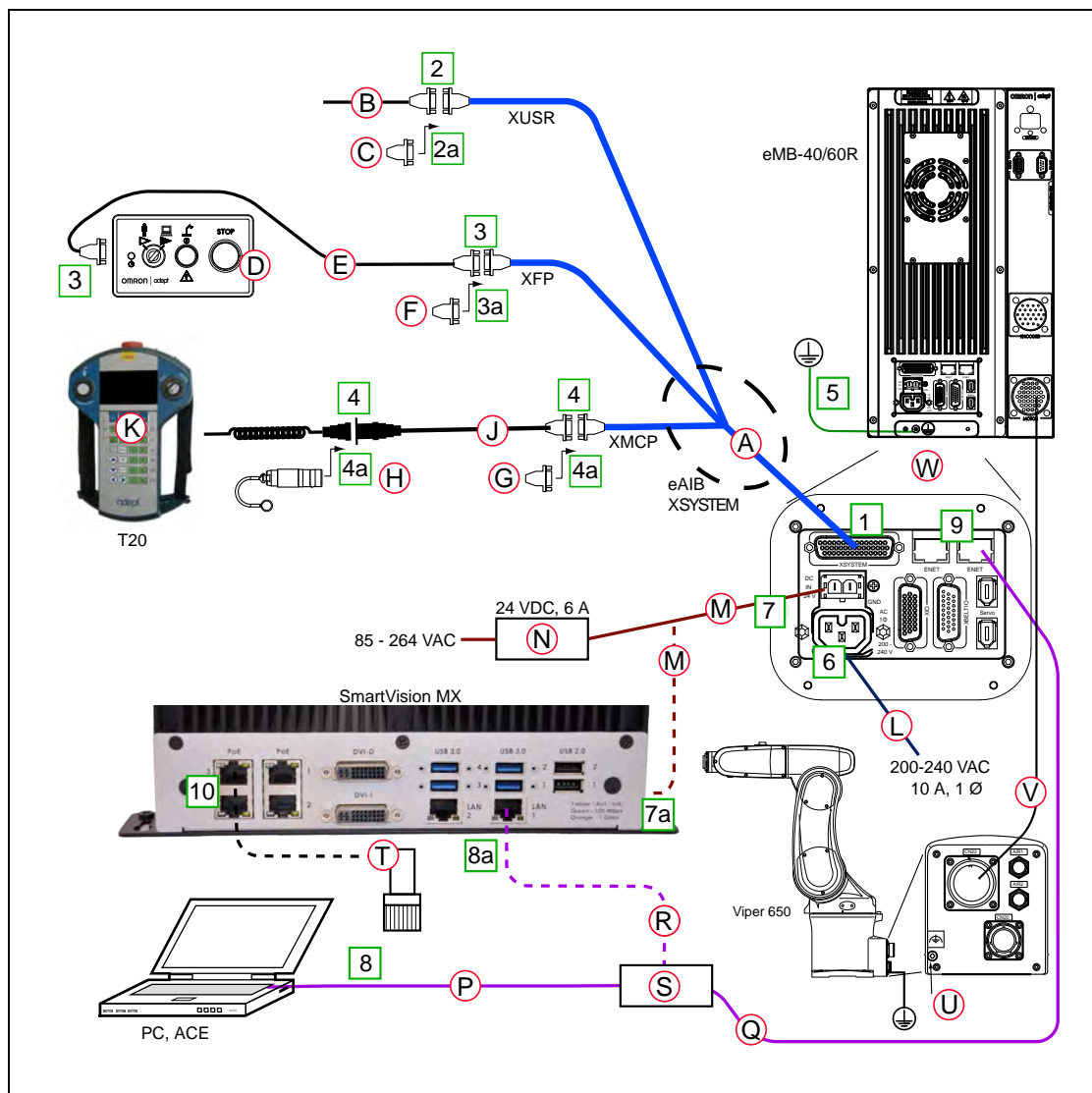

Figure 5-1. System Cable Diagram for Viper 650/850 Robots with eMB-40/60R, Pendant, and Vision

The figure includes the optional T20 pendant and optional SmartVision MX industrial PC.

NOTE: See Installing the 24 VDC Cable on page 72 for additional system grounding information.

List of Cables and Parts

Locate the eAIB XSYSTEM cable in the Accessory box. Connect the cables and peripherals as shown in the preceding figure. Parts and steps are covered in the following two tables.

Part	Cable and Parts List	Part #	Standard	Option	User-Supplied
A	eAIB XSYSTEM Cable Assembly	13323-000	X		
B	User E-Stop, Safety Gate	n/a			X
C	XUSR Jumper Plug	04736-000	X		
D	Front Panel	90356-10358	X		
E	Front Panel Cable	10356-10500	X		
F	Front Panel Jumper Plug	10053-000	X		
G	XMCP Jumper Plug	10052-000	X		
H	T20 Pendant Bypass Plug	10048-000	X		
J	T20 Pendant Adapter Cable	10051-003	X		
K	T20 Pendant Assembly Optional T20 Pendant Kit (10046-010) includes items H, J, and K.	10054-010		X	
Items L, M and N below are available, as an option, in the power supply/cable kit 90565-010.					
L	AC Power Cable	04118-000		X	X
M	24 VDC Power Cable	04120-000		X	X
N	24 VDC, 6 A Power Supply	04536-000		X	X
P	Ethernet Cable - PC ->Switch, if used	n/a			X
Q	Ethernet Cable - switch -> eMB-40/60R	n/a			X
R	Ethernet Cable - switch -> SmartVision MX	n/a			X

Part	Cable and Parts List	Part #	Standard	Option	User-Supplied
S	Ethernet switch, if used	n/a		X	X
T	Camera and cable	n/a		X	X
U	Grounding Terminal, M5	n/a			X
V	Arm Power/Signal Cable	05438-000	X		
W	eMB-40/60R Interface Panel	n/a	X		

The XUSR, XMCP, and XFP jumpers intentionally bypass safety connections so you can test the system functionality during setup.

The XUSR is for a User E-Stop/Safety Gate or a Muted Safety Gate. The jumper plug is required if neither of these is used.

Either the Front Panel or the Front Panel plug must be used.

Either the T20 Pendant , T20 Bypass Plug, or XMCP Jumper Plug must be used.



WARNING: Under no circumstances should you run a Viper system, in production mode, with all three jumpers installed. This would leave the system with no E-Stops.

Cable Installation Overview

Power requirements for the SmartVision MX industrial PC are covered in that user guide. For 24 VDC, both the Viper robot and a SmartVision MX can usually be powered by the same power supply.

Step	Connection	Part
1	Connect eAIB XSYSTEM cable to XSYSTEM on eMB-40/60R.	A
2	Connect a user E-Stop or Muted Safety Gate to the eAIB XSYSTEM cable XUSR connector or	B
2a	verify XUSR jumper plug is installed in eAIB XSYSTEM cable XUSR connector.	C
3	Connect Front Panel cable to Front Panel and eAIB XSYSTEM cable XFP connector or	D, E
3a	if no Front Panel, install FP jumper on eAIB XSYSTEM cable XFP connector. See NOTE after table.	F
4	Connect T20 Pendant adapter cable to eAIB XSYSTEM cable XMCP connector or	J, K
4a	if no T20 Pendant, install XMCP jumper or	G or

Step	Connection	Part
	T20 Pendant Adapter Cable with T20 Pendant bypass plug.	H
5	Connect user-supplied ground to robot. See System Installation on page 57.	n/a
6	Connect 200-240 VAC to AC Input on eMB-40/60R Interface Panel; secure with clamp.	L
7	Connect 24 VDC to DC Input on Interface Panel.	N, M
7a	Connect 24 VDC and shield ground to SmartVision MX, if used. See SmartVision MX user's guide for location.	N, M
8	Connect Ethernet cable from PC to switch, if a switch is used.	S
8a	Connect Ethernet cable from SmartVision MX to switch, if used.	R, S
9	Connect Ethernet cable from switch to eMB-40/60R.	Q, S
10	Connect optional camera and cable to SmartVision MX, if used.	T

NOTE: A front panel ships with each Viper robot system, but you can choose not to use it if you replace its functionality with equivalent circuits. That is beyond the scope of this guide.

5.2 System Cables, with SmartController EX

When the optional SmartController EX is included in the system, the Pendant, Front Panel, and XUSR connections must connect to the SmartController EX.

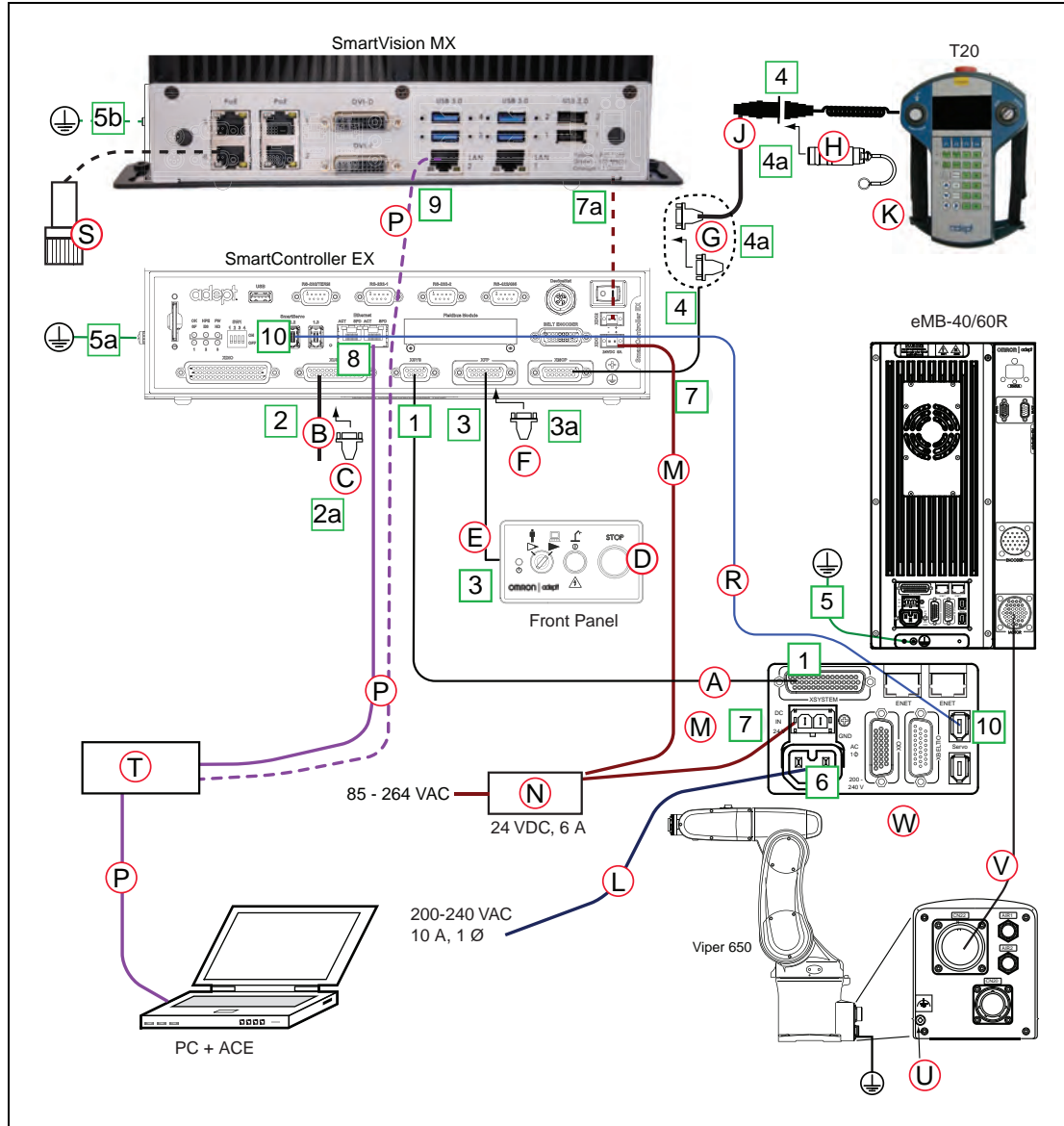

Figure 5-2. System Cable Diagram with SmartController EX

Installing a SmartController EX Motion Controller

Refer to the *SmartController EX User's Guide* for complete information on installing the optional SmartController EX. This list summarizes the main steps.

1. Mount the SmartController EX and Front Panel.
2. Connect the Front Panel to the SmartController EX.

3. Connect the pendant (if purchased) to the SmartController EX.

Connect a jumper plug, if no pendant is being used.

4. Connect user-supplied 24 VDC power to the controller.

Instructions for creating the 24 VDC cable, and power specification, are covered in the *SmartController EX User's Guide*.

5. Install a user-supplied ground wire between the SmartController EX and ground.

List of Cables and Parts

Part	Cable and Parts List	P/N	Standard	Option	User-Supplied
A	eAIB XSYS Cable		X		
B	User E-Stop, Safety Gate	n/a			X
C	XUSR Jumper Plug	04736-000	X		
D	Front Panel	90356-10358	X		
E	Front Panel Cable	10356-10500	X		
F	Front Panel Jumper Plug	10053-000	X		
G	XMCP Jumper Plug	10052-000	X		
H	T20 Pendant Bypass Plug	10048-000	X		
J	T20 Pendant Adapter Cable	10051-003		X	
K	T20 Pendant Assembly Optional T20 Pendant Kit (10046-010) includes items H, J and K.	10054-010		X	
Items L, M and N below are available, as an option, in the power supply/cable kit 90565-010.					
L	AC Power Cable	04118-000		X	X
M	24 VDC Power Cable	04120-000		X	X
N	24 VDC, 6 A Power Supply	04536-000		X	X
P	Ethernet Cable, PC - SmartController EX,	n/a			X

Part	Cable and Parts List	P/N	Standard	Option	User-Supplied
	SmartVision MX if used				
R	IEEE 1394 cable	13632-045	X		
S	Camera and cable	n/a		X	X
T	Switch, if used	n/a			X
U	M5 Grounding Terminal		X		
V	Arm Power/Signal Cable		X		
W	Robot Interface Panel		X		

The XUSR, XMCP, and XFP jumpers intentionally bypass safety connections so you can test the system functionality during setup.

The XUSR is for a User E-Stop/Safety Gate or a Muted Safety Gate. The jumper plug is required if neither of these is used.

Either the Front Panel or the Front Panel plug must be used.

Either the T20 Pendant , T20 Bypass Plug, or XMCP Jumper Plug must be used.



WARNING: Under no circumstances should you run a Viper system, in production mode, with all three jumpers installed. This would leave the system with no E-Stops.

Cable Installation Overview

Step	Connection	Part
1	Connect eAIB XSYS cable to XSYSTEM on eMB-40/60R	A
2	Connect a user E-Stop or Muted Safety Gate to the XUSR connector or	B
2a	verify XUSR jumper plug is installed in XUSR connector.	C
3	Connect Front Panel cable to Front Panel and XFP connector or	D, E
3a	if no Front Panel, install FP jumper on XFP connector.	F
4	Connect Pendant adapter cable to XMCP connector or	J, K
4a	if no Pendant, install XMCP jumper or bypass plug.	G or H
5	Connect user-supplied ground to robot. See robot user's guide for location.	n/a
5a	Connect user-supplied ground to SmartController EX. See SmartController EX user's guide for location.	n/a
5b	Connect user-supplied ground to SmartVision MX, if used. See SmartVision MX user's guide for location.	n/a

Step	Connection	Part
6	Connect 200-240 VAC to AC Input on eMB-40/60R; secure with clamp.	L
7	Connect 24 VDC to DC Input on eMB-40/60R and SmartController EX.	N,M
7a	Connect 24 VDC to SmartVision MX, if used.	N,M
8	Connect Ethernet cable from PC to SmartController EX.	P
9	Connect Ethernet cable to SmartVision MX, if used.	Q
10	Connect IEEE 1394 cable between SmartController EX and eMB-40/60R SmartServo.	R
11	Connect optional camera and cable to SmartVision MX, if used.	S

5.3 Optional Cables

XIO Breakout Cable

The XIO Breakout cable is for using the I/O on the eAIB. This cable provides access to 12 inputs and 8 outputs (5 m). Refer to XIO Breakout Cable on page 52 for more information.

DB9 Splitter Cable

An optional Y cable attaches at the SmartController EX XSYS connector and splits it into two XSYS connectors. This is part number 00411-000. See the Single and Multiple Robot Configuration Guide.

eAIB XBELT IO Adapter Cable

The optional eAIB XBELT IO Adapter cable split the eAIB XBELTIO port into a belt encoder lead, an Intelligent Force Sensor or IO Blox lead, and an RS-232 lead. If the system has a SmartController EX, this is only needed for Intelligent Force Sensing.

Find the pin connection diagrams in the figures below.

SmartController EX Belt Encoder Y-Adapter Cable

The optional SmartController EX Belt Encoder Y-Adapter cable split the SmartController EX BELT ENCODER port into two belt encoder leads for encoders 1 and 2 and encoders 3 and 4.

Find the pin connection diagrams in the figures below.

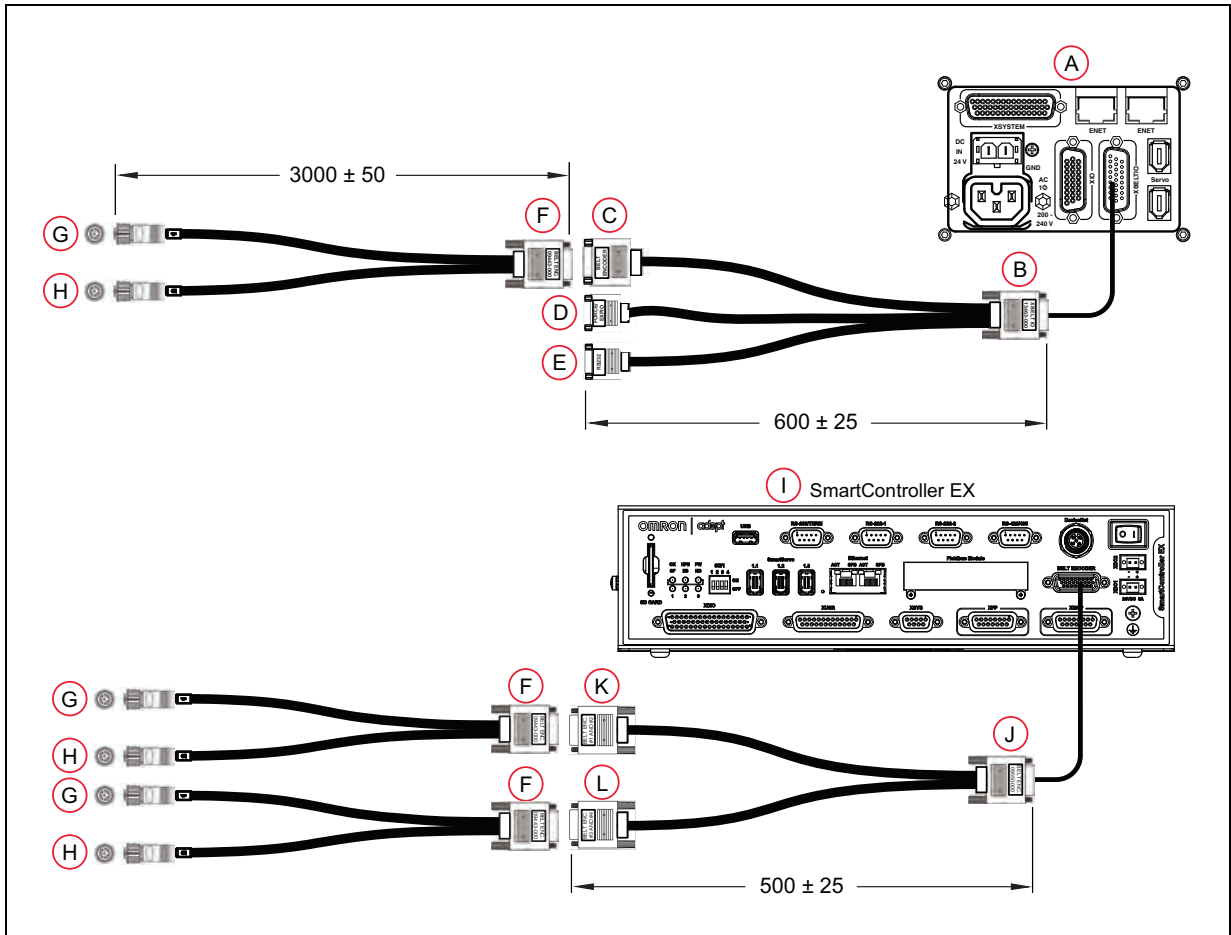

Figure 5-3. System Cable Diagram with Belt Encoders (Units in mm)

Table 5-1. Conveyor Belt Encoder Cables Description

Item	Description	Part #	Standard	Option	User-supplied	Notes
A	Robot Interface Panel	n/a	X			
B	eAIB XBELT IO Adapter Cable Connector	13463-000		X	X	HDB26 Female
C	Belt Branch Connector					DB 15 Male
D	Force / EXPIO Branch Connector					DB9 Male
E	RS232 Branch Connector					DB9 Male
F	Belt Y Splitter Cable Connector	09443-000		X	X	DB15 Female
G	Belt Encoder 1 Connector					M12 Female, 8-pin

5.3 Optional Cables

Item	Description	Part #	Standard	Option	User-supplied	Notes
H	Belt Encoder 2 Connector					M12 Female, 8-pin
I	SmartController EX (optional)	19300-000		X		
J	SmartController EX Belt Encoder Y Adapter Cable Connector	09550-000		X	X	HDB26 Female
K	Belt Branch Connector, Encoder 1 and 2		DB15 Male			
L	Belt Branch Connector, Encoder 3 and 4		DB15 Male			

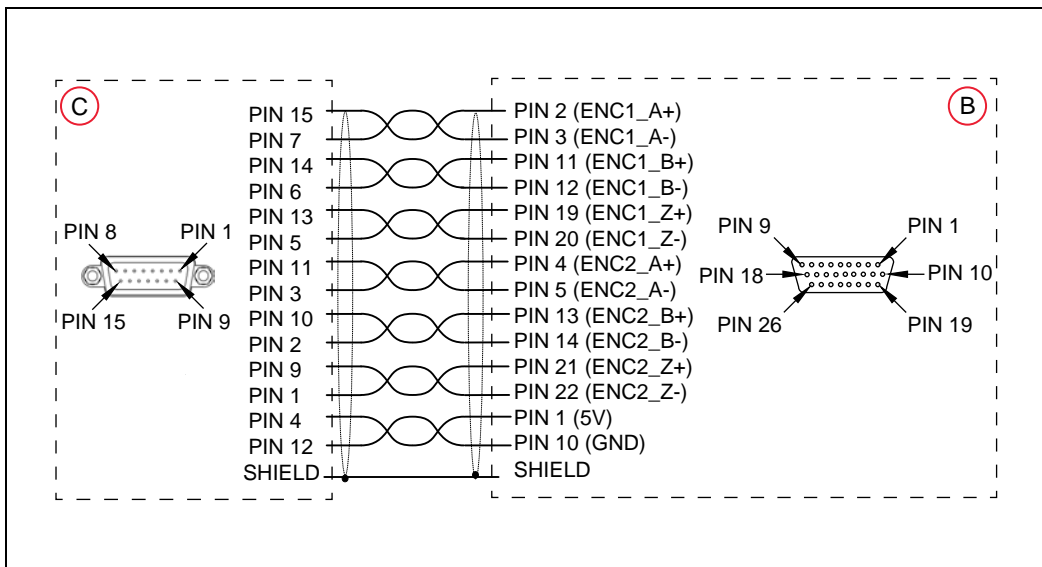

Figure 5-4. eAIB XBELT IO Adapter Cable Pinout - Encoder 1 and 2 Connections

NOTE: Cable shields connected to DSUB shell.

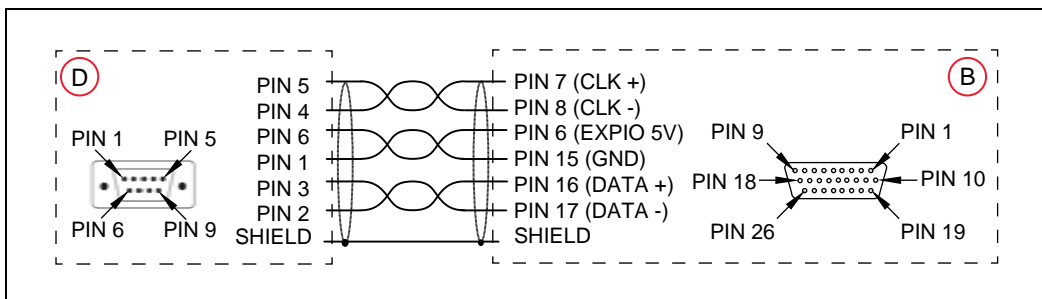

Figure 5-5. eAIB XBELT IO Adapter Cable Pinout - Force / EXPIO Connections

NOTE: Cable shields connected to DSUB shell.

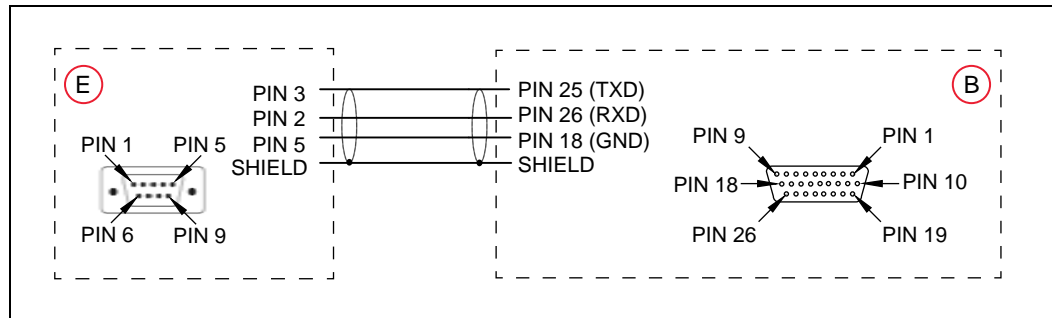

Figure 5-6. eAIB XBELT IO Adapter Cable Pinout - RS232 Connections

NOTE: Cable shields connected to DSUB shell.

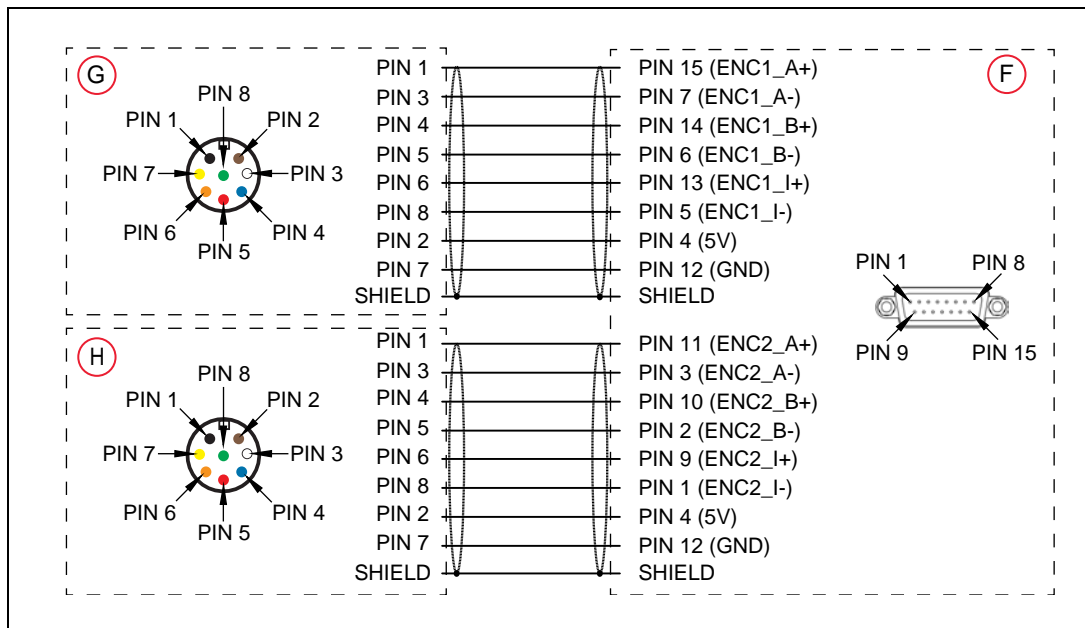

Figure 5-7. Belt Y Splitter Cable Pinout - 2 Encoder Connections

NOTE: Cable shields connected to DSUB shell.

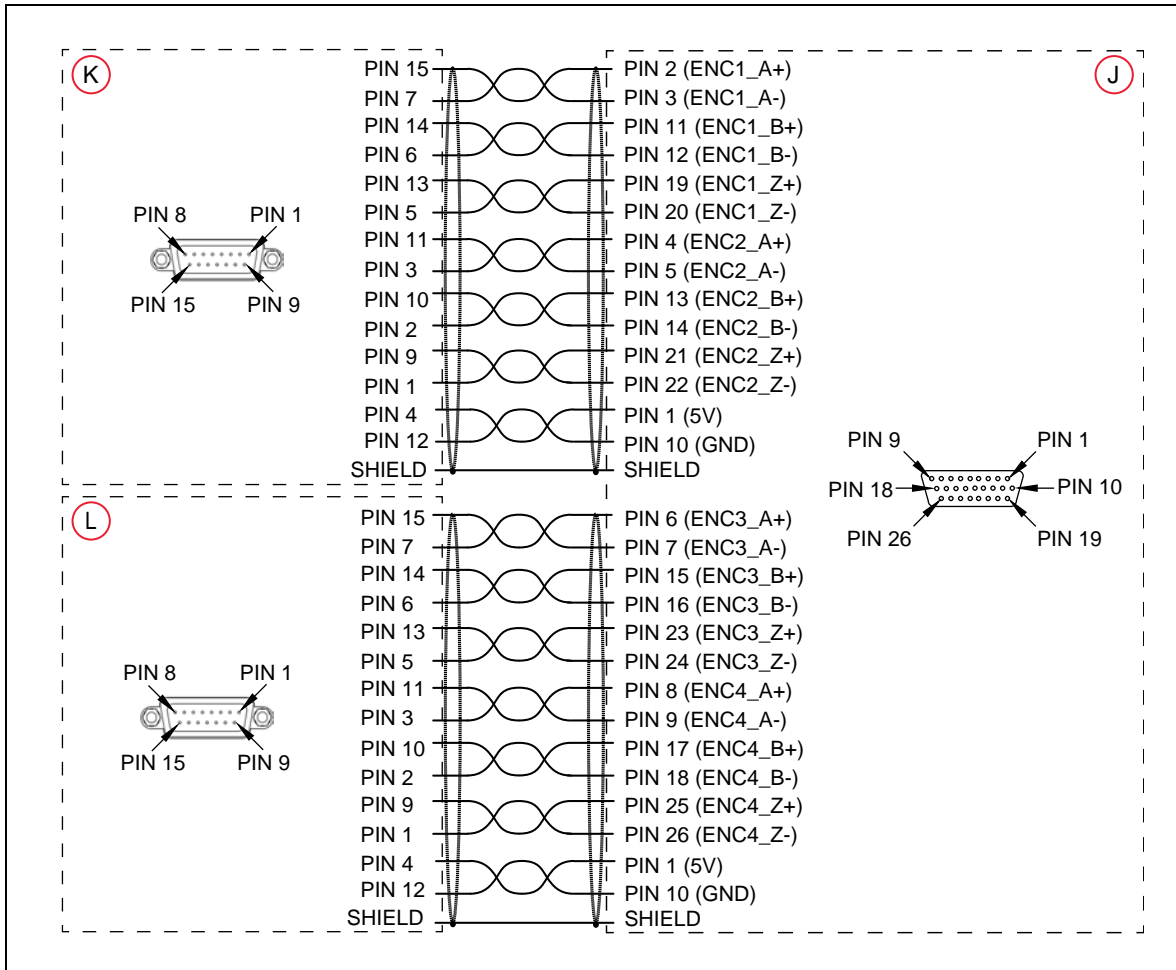

Figure 5-8. SmartController EX Belt Encoder Y Adapter Cable Connections

NOTE: Cable shields connected to DSUB shell.

5.4 ACE Software

Load the ACE software onto the PC and connect it to the eMB-40/60R via an Ethernet cable. Your system may have an Ethernet switch between the two.

The ACE software is installed from the ACE software media.

1. Insert the media into your PC.
If Autoplay is enabled, the ACE software menu is displayed. If Autoplay is disabled, you will need to manually start the disk.
2. Especially if you are upgrading your ACE software installation: from the ACE software media menu, click Read Important Information.
3. From the ACE software media menu, select:

Install the ACE Software

The ACE Setup wizard opens.

4. Follow the online instructions as you step through the installation process.
5. When the installation is complete, click Finish.
6. After closing the ACE Setup wizard, click Exit to close the menu.

NOTE: You will have to restart the PC after installing ACE software.

5.5 Connecting Cables from the eMB-40/60R to the Robot

The cable between the robot and the eMB-40/60R is called the Arm Power/Signal cable.

1. Connect one end of the Arm Power/Signal cable to the CN22 connector on the back plate of the robot. Tighten the thumb-screw securely.

For both ends of the cable, line up the slot with the matching key in the connector, apply firm pressure straight in, and thread the lock ring fully onto the connector. There should be no visible threads when connected.

2. Connect the other end of the cable to the large, circular connector on the eMB-40/60R. See Figure 5-1.



WARNING: Verify that all connectors are fully-inserted and screwed down. Failure to do this could cause unexpected robot motion. Also, a connector could get pulled out or dislodged unexpectedly.

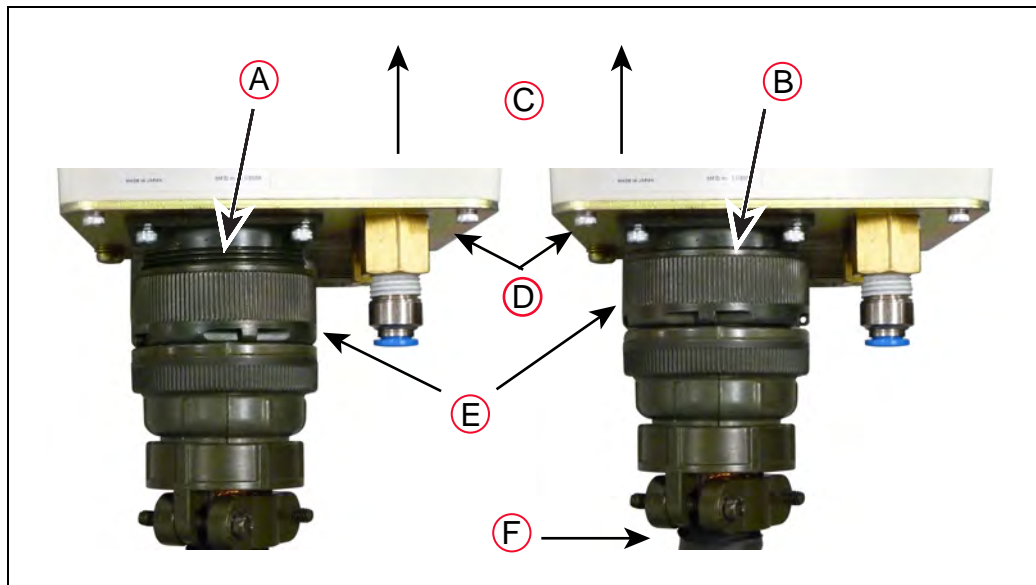

Figure 5-9. Incorrect and Correct Arm Power/Signal Cable Insertion

Key	Meaning	Key	Meaning
A	Incorrect Assembly:No threads should be visible!	D	Viper Interface Panel
B	Correct Assembly:No threads are visible	E	Lock Ring
C	Viper Bodies	F	Arm Power/Signal Cable

5.6 Connecting 24 VDC Power to eMB-40/60R Servo Controller

Specifications for 24 VDC Power

Table 5-2. Specifications for 24 VDC User-Supplied Power Supply

Customer-Supplied Power Supply	24 VDC ($\pm 10\%$), 150 W (6 A) ($21.6 \text{ V} < V_{in} < 26.4 \text{ V}$)
Circuit Protection ¹	Output must be less than 300 W peak or 8 Amp in-line fuse
Power Cabling	1.5 – 1.85 mm ² (16-14 AWG)
Shield Termination	Cable shield connected to frame ground on power supply and ground point on eMB-40/60R. See User-Supplied 24 VDC Cable on page 72.
¹ User-supplied 24 VDC power supply must incorporate overload protection to limit peak power to less than 300 W, or 8 A in-line fuse protection must be added to the 24 V power source.	

NOTE: Fuse information is located on the eMB-40/60R electronics.

The power requirements for the user-supplied power supply will vary depending on the configuration of the robot and connected devices. We recommend a 24 V, 6 A power supply to allow for startup current draw and load from connected user devices, such as digital I/O loads.



CAUTION: Make sure you select a 24 VDC power supply that meets the specifications in the preceding table. Using an underrated supply can cause system problems and prevent your equipment from operating correctly. See the following table for a recommended power supply.

Table 5-3. Recommended 24 VDC Power Supplies

Vendor Name	Model	Ratings	Mount
OMRON	S8FS-G15024C	24 VDC, 6.5 A, 150 W	Front Mount
OMRON	S8FS-G15024CD	24 VDC, 6.5 A, 150 W	DIN-Rail Mount
OMRON	S8VK-S24024C	24 VDC, 10 A, 240 W	Front Mount
OMRON	S8VK-S24024CD	24 VDC, 10 A, 240 W	DIN-Rail Mount

Details for 24 VDC Mating Connector

The 24 VDC mating connector and two pins are supplied with each system. They are shipped in the cable/accessories box.

Table 5-4. 24 VDC Mating Connector Specs

Connector Details  A: Ground (pin 1, labeled on under side) B : +24 VDC	Connector receptacle, 2 position, type: Molex Saber, 18 A, 2-Pin
	Molex P/N 44441-2002
	Digi-Key P/N WM18463-ND
Pin Details 	Molex connector crimp terminal, female, 14-18 AWG
	Molex P/N 43375-0001
	Digi-Key P/N WM18493-ND
Recommended crimping tool, Molex Hand Crimper	Molex P/N 63811-0400
	Digi-Key P/N WM9907-ND

NOTE: The 24 VDC cable is not supplied with the system, but is available in the optional Power Cable kit. See List of Cables and Parts on page 58.

Procedure for Creating 24 VDC Cable

1. Locate the connector and pins from the preceding table.
2. Use shielded two-conductor cable with 14-16 AWG wire to create the 24 VDC cable. Select the wire length to safely reach from the user-supplied 24 VDC power supply to the eMB-40/60R base.

NOTE: You also must create a separate 24 VDC cable for the SmartController EX. That cable uses a different style of connector. See the *SmartController EX User's Guide*.

3. Crimp the pins onto the wires using the recommended crimping tool.
4. Insert the pins into the connector. Confirm that the +24 V and ground wires are in the correct terminals in the plug.
5. Install a user-supplied ring lug (for an M3 screw) on the shield at the eMB-40/60R end of the cable.
6. Prepare the opposite end of the cable for connection to the user-supplied 24 VDC power supply, including a terminal to attach the cable shield to frame ground.

Installing the 24 VDC Cable

Do not turn on the 24 VDC power until instructed to do so in the next chapter.

1. Connect one end of the shielded 24 VDC cable to your user-supplied 24 VDC power supply. See User-Supplied 24 VDC Cable on page 72. The cable shield should be connected to frame ground on the power supply.
2. Plug the mating connector end of the 24 VDC cable into the 24 VDC connector on the interface panel on the back of the eMB-40/60R. The cable shield should be connected to the ground point on the interface panel.

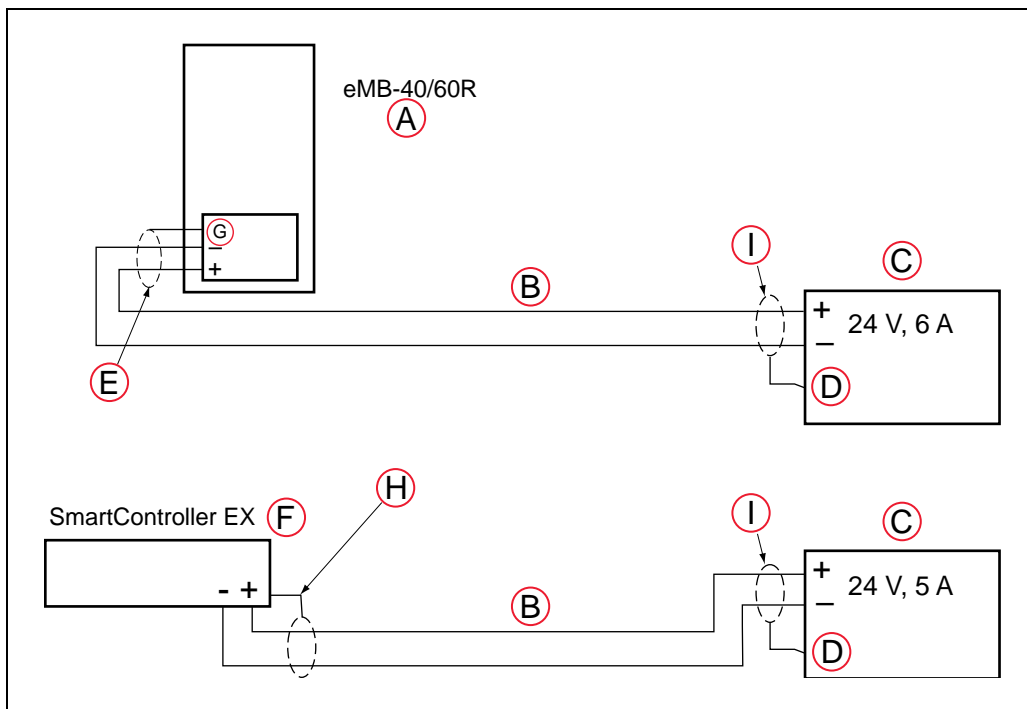

Figure 5-10. User-Supplied 24 VDC Cable

Key	Meaning	Key	Meaning
A	eMB-40/60R	F	SmartController EX Option
B	User-Supplied Shielded Power Cable	G	Ground
C	User-Supplied Power Supply 24 VDC	H	Attach shield from user-supplied cable to side of controller using star washer and M3 x 6 screw.
D	Attach shield from user supplied cables to frame ground on power supply.	I	Attach shield from user-supplied cables to frame ground on power supply.
E	Attach shield from user-supplied cable to ground screw on eMB-40/60R Interface Panel.		

NOTE: We recommend that DC power be delivered over shielded cables, with the shield connected to frame ground at the power supply, and to the ground points shown in the diagram above for the eMB-40/60R and SmartController. The length of the wire from the cable shield to the ground points should be less than 50 mm.

5.7 Connecting 200-240 VAC Power to eMB-40/60R



WARNING: ELECTROCUTION RISK

Ensure compliance with all local and national safety and electrical codes for the installation and operation of the robot system.



WARNING: ELECTROCUTION RISK

Appropriately-sized Branch Circuit Protection and Lockout / Tagout Capability must be provided in accordance with the National Electrical Code and any local codes.

Specifications for AC Power

Table 5-5. Specifications for 200/240 VAC User-Supplied Power Supply

Auto-Ranging Nominal Voltage Ranges	Minimum Operating Voltage ¹	Maximum Operating Voltage	Frequency / Phasing	Recommended External Circuit Breaker, User-Supplied
200 to 240 V	180 V	264 V	50/60 Hz 1-phase	10 Amps

¹Specifications are established at nominal line voltage. Low line voltage can affect robot performance.

NOTE: The robot system is intended to be installed as a piece of equipment in a permanently-installed system.

Table 5-6. Typical Robot Power Consumption¹

Robot	Move	Average Power	Peak Power ²
Viper 650	No load - Adept cycle ³	371 W	947 W
	5.0 kg - Adept cycle ³	477 W	1526 W
	5.0 kg - all joints move	834 W	2088 W
Viper 850	No load - Adept cycle ³	358 W	1237 W
	5.0 kg - Adept cycle ³	407 W	1202 W
	5.0 kg - all joints move	704	2090

1Typical power data is with 220 VAC, 60 Hz, 1-phase nominal input.

2For short durations (100 ms).

3Adept cycle: The robot tool performs continuous path, straight-line motions 25 mm (1 inch) up, 305 mm (12 inches) over, 25 mm (1 inch) down, and back along the same path, at 20° C ambient. COARSE is enabled and BREAKs are used at each end location. Not achievable over all paths.

**DANGER: ELECTROCUTION RISK**

AC power installation must be performed by a skilled and instructed person - refer to the *Robot Safety Guide*. During installation, unauthorized third parties must be prevented from turning on power through the use of fail-safe lockout measures, as mandated by ISO 10218-1, Clause 5.2.4.

Failure to use appropriate power (less than or more than the rated voltage range of 200-240 VAC) can lead to malfunction or failures of the robot or hazardous situations.

Facility Overvoltage Protection

The user must protect the robot from excessive overvoltages and voltage spikes. If the country of installation requires a CE-certified installation, or compliance with IEC 1131-2, the following information may be helpful: IEC 1131-2 requires that the installation must ensure that Category II overvoltages (i.e., line spikes not directly due to lightning strikes) are not exceeded. Transient overvoltages at the point of connection to the power source shall be controlled not to exceed overvoltage Category II, i.e., not higher than the impulse voltage corresponding to the rated voltage for the basic insulation. The user-supplied equipment or transient suppressor shall be capable of absorbing the energy in the transient.

In the industrial environment, non-periodic over-voltage peaks may appear on mains power supply lines as a result of power interruptions to high-energy equipment (such as a blown fuse on one branch in a 3-phase system). This will cause high-current pulses at relatively low voltage levels. The user shall take the necessary steps to prevent damage to the robot system (such as by interposing a transformer). See IEC 1131-4 for additional information.

AC Power Diagrams

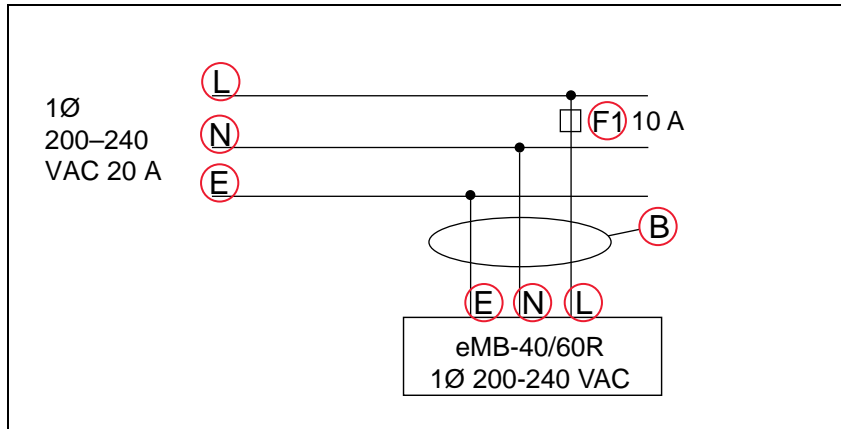

Figure 5-11. Typical AC Power Installation with Single-Phase Supply

Key	Meaning	Key	Meaning
B	User-Supplied AC Power Cable	L	Line
E	Earth Ground	N	Neutral
F1	Fuse, 10A		
NOTE: F1 is user-supplied, must be slow-blow.			

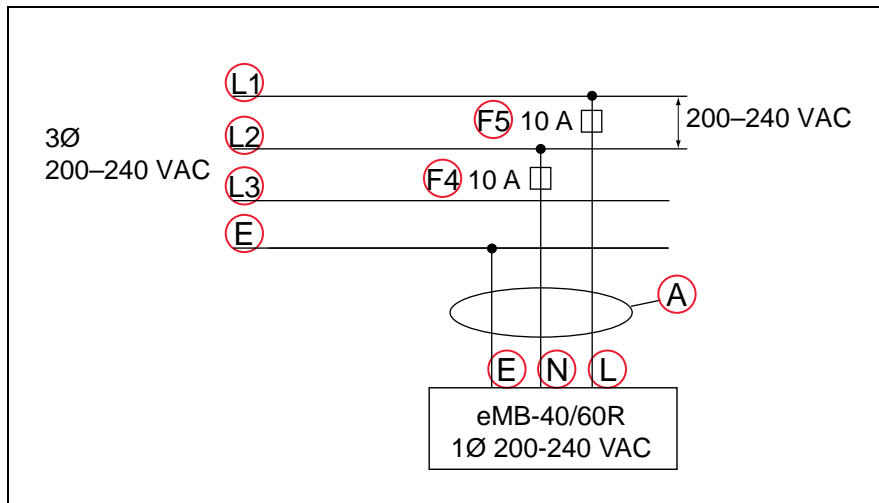

Figure 5-12. Single-Phase Load across L1 and L2 of a Three-Phase Supply

Key	Meaning	Key	Meaning
A	User-Supplied AC Power Cable	L1	Line 1
E	Earth Ground	L2	Line 2
F4	Fuse, 10A	L3	Line 3
F5	Fuse, 10A	N	Neutral
L	Line 1		
NOTE: F1 is user-supplied, must be slow-blow.			

Details for AC Mating Connector

The AC mating connector is supplied with each system. It is shipped in the cable/accessories box. The supplied plug is internally labeled for the AC power connections (L, E, N).

Table 5-7. AC Mating Connector Details

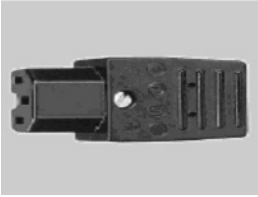
AC Connector details 	AC in-line power plug, straight, female, screw terminal, 10 A, 250 VAC
	Qualtek P/N 709-00/00
	Digi-Key P/N Q217-ND

NOTE: The AC power cable is not supplied with the system, but is available in the optional Power Cable kit.

Procedure for Creating 200-240 VAC Cable

1. Locate the AC mating connector shown in the preceding table.
2. Open the connector by unscrewing the screw on the shell and removing the cover.
3. Loosen the two screws on the cable clamp. See AC Power Mating Connector on page 77.
4. Use 18 AWG wire to create the AC power cable. Select the wire length to safely reach from the user-supplied AC power source to the eMB-40/60R base.
5. Strip approximately 18 to 24 mm of insulation from each of the three wires.
6. Insert the wires into the connector through the removable bushing.
7. Connect each wire to the correct terminal screw, and tighten the screw firmly.
8. Tighten the screws on the cable clamp.

9. Replace the cover and tighten the screw to seal the connector.
10. Prepare the opposite end of the cable for connection to the facility AC power source.

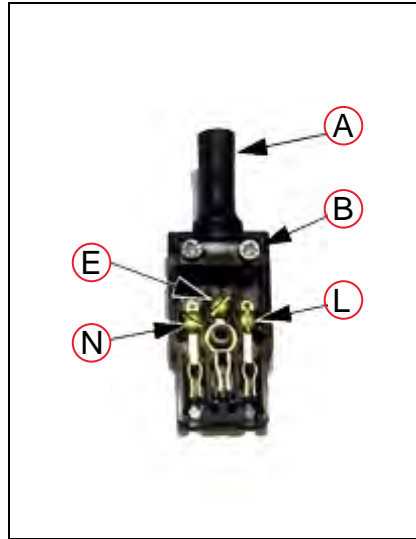

Figure 5-13. AC Power Mating Connector

Key	Meaning	Key	Meaning
A	Removable Bushing	E	Earth
B	Cable Clamp	N	Neutral
L	Line		

Installing AC Power Cable to eMB-40/60R

1. Connect the unterminated end of the AC power cable to your facility AC power source. See Figure 5-11. and Figure 5-12.

Do not turn on AC power at this time.

2. Plug the AC connector into the AC power connector on the interface panel on the eMB-40/60R.
3. Secure the AC connector with the locking latch.

5.8 Grounding the Robot System

Proper grounding is essential for safe and reliable robot operation. Follow these recommendations to properly ground your robot system.



WARNING: ELECTROCUTION RISK

Wiring must be performed by authorized or certified personnel. Failure to observe this precaution may result in fire or electric shock.

NOTE: Ground the grounding terminal of the robot with a wire of 12 AWG or larger. Ground resistance must be $\leq 10 \Omega$.

NOTE: Use a dedicated grounding wire and grounding electrode. Do not share them with any other electric power or power equipment, such as a welder.

Ground Point on Robot Base

The user can install a protective earth ground wire at the robot base to ground the robot. See the following figure. The ground wire is user-supplied.

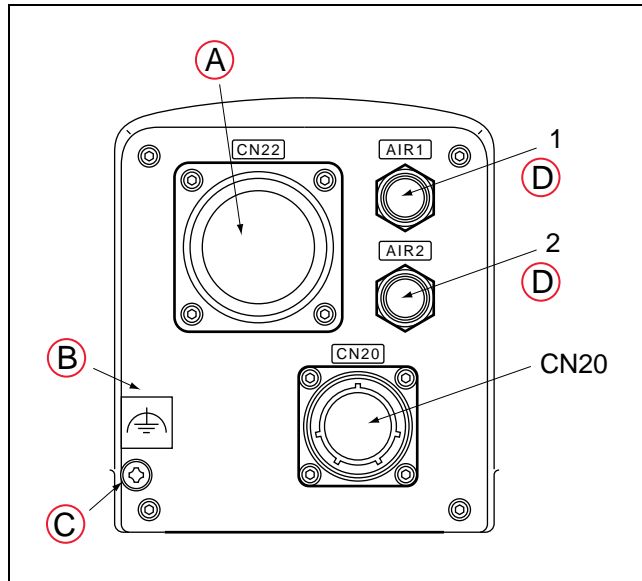

Figure 5-14. Ground Point on Robot Base

Key	Meaning	Key	Meaning
A	CN22 Power/Signal Cable to eMB-40/60R	C	Grounding Terminal, M5
B	Ground Label	D	Air 1 and Air 2

Ground Point on eMotionBlox-40/60R

The user can install a ground wire at the eMB-40/60R chassis. Use the hole below the eMB-40/60R interface panel. See the following figure. The user should provide a ground wire and use the provided M4 screw and external tooth lock washer to connect to earth ground. Make sure to tighten the screw on the ground wire to create a proper ground connection. Optionally, two tapped holes are provided to attach user-supplied strain relief.

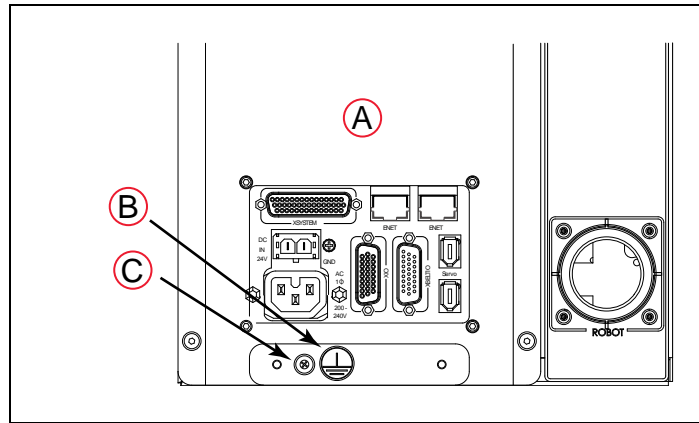

Figure 5-15. User Ground Location

Key	Meaning	Key	Meaning
A	eMB-40/60R Interface Panel	C	Ground Screw
B	Ground Label		

Robot-Mounted Equipment Grounding

The robot tool flange is not reliably grounded to the robot base. If hazardous voltages are present at any user-supplied robot-mounted equipment or tooling, you must install a ground connection from that equipment/tooling to the ground point on the robot base. Hazardous voltages can be considered anything in excess of 30 VAC (42.4 VAC peak) or 60 VDC.



DANGER: Failing to ground robot-mounted equipment or tooling that uses hazardous voltages could lead to injury or death of a person touching the end-effector when an electrical fault condition exists.

5.9 Installing User-Supplied Safety Equipment

The user is responsible for installing safety barriers to protect personnel from coming in contact with the robot unintentionally. Depending on the design of the workcell, safety gates, light curtains, and emergency stop devices can be used to create a safe environment. Read the *Robot Safety Guide* for a discussion of safety issues.

The user-supplied safety and power-control equipment connects to the system through the XUSR and XFP connectors on the eMB-40/60R XSYSTEM cable. The XUSR connector (25-pin) and XFP (15-pin) connector are both female D-sub connectors. Refer to the following table for the XUSR pin-out descriptions, and Table 5-9. for the XFP pin-out descriptions. See the figure E-Stop Circuit on XUSR and XFP Connectors on page 83 for the XUSR wiring diagram.

Table 5-8. Contacts Provided by the XUSR Connector

Pin Pairs	Description	Comments
Voltage-Free Contacts Provided by Customer		
1, 14	User E-Stop CH 1 (mushroom push-button, safety gates, etc.)	N/C contacts, Shorted if NOT Used
2, 15	User E-Stop CH 2 (same as pins 1, 14)	N/C contacts, Shorted if NOT Used
3, 16	Line E-Stop (used for other robot or assembly line E-Stop inter-connection. Does not affect E-Stop indication (pins 7, 20))	N/C contacts, Shorted if NOT Used
4, 17	Line E-Stop (same as pins 3, 16)	N/C contacts, Shorted if NOT Used
5, 18	Muted safety gate CH 1 (causes E-Stop in Automatic mode only)	N/C contacts, Shorted if NOT Used
6, 19	Muted Safety Gate CH 2 (same as pins 5, 18)	N/C contacts, Shorted if NOT Used
Voltage-Free Contacts provided by Viper		
7, 20	E-Stop indication CH 1	Contacts are closed when Front Panel, pendant, and customer E-Stops are <i>not</i> tripped
8, 21	E-Stop indication CH 2 (same as pins 7, 20)	Contacts are closed when Front Panel, pendant, and customer E-Stops are <i>not</i> tripped
9, 22	Manual/Automatic indication CH 1	Contacts are closed in Automatic mode
10, 23	Manual/Automatic indication CH 2	Contacts are closed in Automatic mode
11, 12, 13, 24, 25	No connection	

Table 5-9. Contacts Provided by the XFP Connector

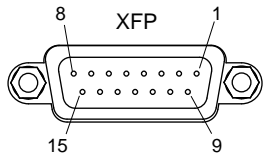
Pin Pairs	Description	Requirements for User-Supplied Front Panel
Voltage-Free Contacts Provided by Customer		
1, 9	Front Panel E-Stop CH 1	User must supply N/C contacts
2, 10	Front Panel E-Stop CH 2	User must supply N/C contacts
3, 11	Remote Manual/Automatic switch CH 1. Manual = Open Automatic = Closed	Optional - jumper closed for Auto Mode-only operation
4, 12	Remote Manual/Automatic switch CH 2. Manual = Open Automatic = Closed	Optional - jumper closed for Auto Mode-only operation
6, 14	Remote High Power on/off momentary push-button	User must supply momentary push-button to enable High Power to system
Non-voltage-Free Contacts		
5, 13	System-Supplied 5 VDC and GND for High Power On/Off Switch Lamp	User must supply lamp, or use 1 W, 47 ohm resistor - system will not operate if not present
7, 15 ^a	Controller system 5 V power on LED, 5 V, 20 mA	Optional - indicator only
8	No connection	
 <p>The diagram shows a rectangular XFP connector with two mounting lugs on the sides. It has 15 pins in total, arranged in two rows of 8 and 7. Pin 1 is at the top right, pin 8 is at the top left, pin 9 is at the bottom right, and pin 15 is at the bottom left.</p>		
See the figure Front Panel Schematic on page 85 for a schematic diagram of the Front Panel.		
^a Users must exercise caution to avoid inadvertently connecting 24 V signals to these pins, because this will damage the electronics.		

NOTE: The system was evaluated by Underwriters Laboratory with a Front Panel. Using a substitute front panel could void UL compliance.

Table 5-10. Remote Pendant Connections on the XMCP Connector

Pin XMCP (15-Pin D-Sub)	Description
1, 9	Pendant E-Stop Push-button CH 1
2, 10	Pendant E-Stop Push-button CH 2
3, 11	Pendant Enable CH 1 (Hold-to-run)
4, 12	Pendant Enable CH 2 (Hold-to-run)
13	Serial GND/Logic GND
7	Pendant TXD: "eV+ to Pendant TXD"
8	Pendant RXD: "eV+ to Pendant RXD"
14	No connection
15	No connection
Shield	Shield GND
6	24 V
5	No connection

The following figure shows an E-Stop diagram for the system. See Emergency Stop Circuits on page 85 for a description of the functionality of this circuit.

Key	Meaning	Key	Meaning
A	ESTOP 24 V Source	K	Auto/Manual Output
B	Bulb, 6 V, 1.2 W	L	T20 Pendant Enable
C	Front Panel High Power ON/OFF	M	Muted Safety Gate - Active in Auto mode only (Jumper closed when not used)
D	Front Panel ESTOP Pushbutton	N	Manual Mode Path
E	T20 ESTOP Push-button	O	Auto Mode Path
F	Front Panel Auto/Manual Key-switch	P	Force-Guided Relay Cycle Check Control Circuit
G	ESTOP Ground	Q	User ESTOP Output
H	User E-Stop and Gate Interlock NOTE: Jumper closed when not used, MUST open both channels independently if used.		
I	Coil	R	Single-Phase AC Input, 200-240 VAC
J	LINE E-Stop (External User E-Stop System)	S	High Power to Amplifiers (Internal Connections)

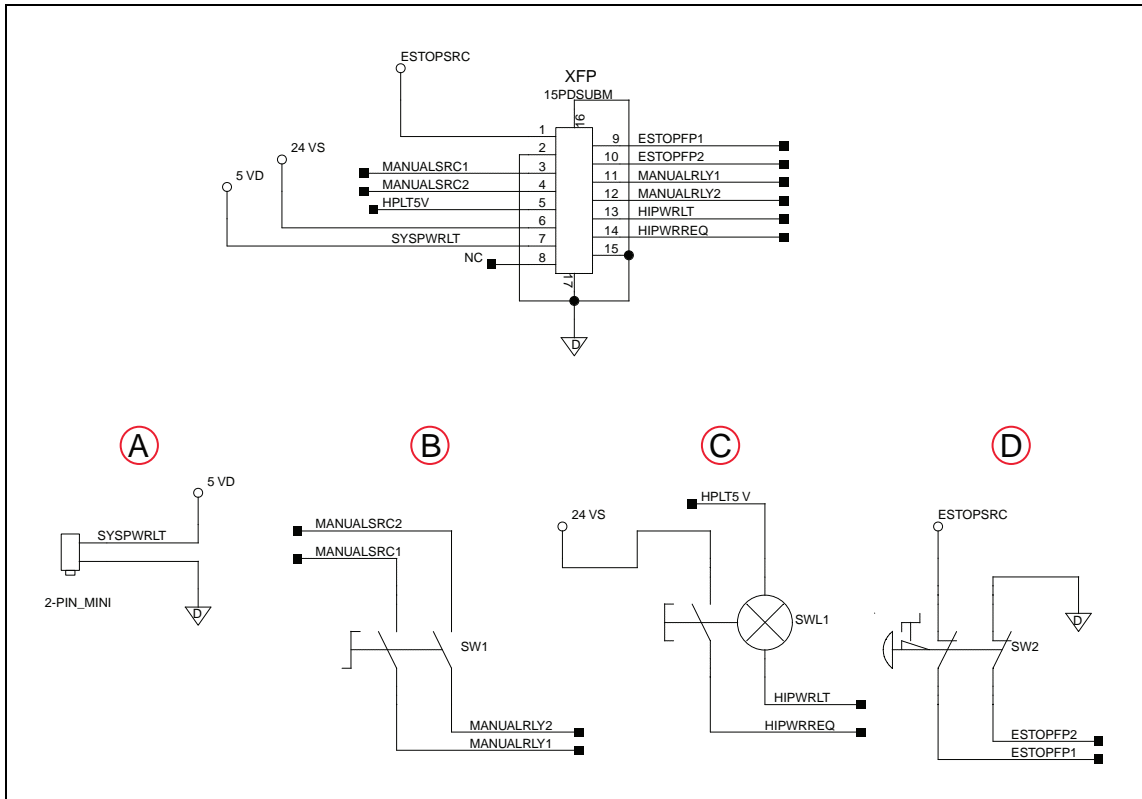

Figure 5-17. Front Panel Schematic

Key	Meaning	Key	Meaning
A	Front Panel Schematic	D	HIGH POWER ON/OFF
B	System Power LED	E	EMERGENCY STOP
C	MANUAL/AUTO		

Emergency Stop Circuits

The eMB-40/60R XSYSTEM cable provides connections for Emergency Stop (E-Stop) circuits on the XUSR and XFP connectors. This gives the controller system the ability to duplicate E-Stop functionality from a remote location using voltage-free contacts. See Figure 5-16.

The XUSR connector provides external two-channel E-Stop input on pin pairs 1, 14 and 2, 15. The XFP connector provides two-channel E-Stop input on pin pairs 1, 9 and 2, 10.

NOTE: These pin pairs must be shorted if not used. Both channels must open independently if used. The controller will flag an error state if one channel is jumpered closed and the other channel is opened, although an Emergency Stop will still occur. It will also flag an error state if the independent channels are crossed, meaning one line from each channel is accidentally connected to the other channel.

User E-Stop Indication Contacts - Remote Sensing of E-Stop

These contacts provide a method to indicate the status of the ESTOP chain, inclusive of the Front Panel Emergency Stop push-button, the pendant Emergency Stop push-button, and the User Emergency Stop Contacts.

NOTE: These contacts do not indicate the status of any connections below the User E-Stop contacts. Thus, they will NOT indicate the status of the Line E-Stop, MCP ENABLE, or the Muted Safety gate. If you have a specific need in this area, contact your local Omron support for information on alternate indicating modes.

Two pairs of pins on the XUSR connector (pins 7, 20 and 8, 21) provide voltage-free contacts, one for each channel, to indicate whether the E-Stop chain, as described above, on that channel is closed. Both switches are closed on each of the redundant circuits in normal operation (no E-Stop). The user may use these contacts to generate an E-Stop for other equipment in the workcell. The load on the contacts must not exceed 40 VDC or 30 VAC at a maximum of 1 A.

These voltage-free contacts are provided by a redundant, cyclically-checked, positive-drive, safety relay circuit for Category 3 PL-d per ISO 13849 operation (see Figure 5-16. and the table Contacts Provided by the XFP Connector on page 81 for the customer E-Stop circuitry).

Line E-Stop Input

The XUSR connector on the controller contains a two-channel Line E-Stop input for workcell, production line, or other equipment emergency-stop inputs. Generally, the customer E-Stop Indication contact outputs are used to generate an emergency stop in such external equipment. Thus, if one were to wire the same equipment's outputs into the customer E-Stop input (that is, in series with the local robot's E-Stop push-buttons), a lock-up situation could occur.

The Line E-Stop input comes into the circuit at a point where it cannot affect the customer E-Stop indication relays and will not cause such a lock-up situation. For any situation where two systems should be cross-coupled, for example, the customer E-Stop indication of one controller is to be connected to the input of another controller, the Line E-Stop input is the point to bring in the other controller's output contacts. See the figure E-Stop Circuit on XUSR and XFP Connectors on page 83 for more information.

Do not use the Line E-Stop for such devices as local E-Stop push-buttons, since their status should be reported to the outside on the local user E-Stop indication output contact while the Line E-Stop inputs will not.

Muted Safety Gate E-Stop Circuitry

Two pairs of pins on the XUSR connector (pins 5, 18 and 6, 19) provide connections for a safety gate designed to yield an E-Stop allowing access to the workspace of the robot in Manual mode only, not in Automatic mode. It is up to the customer to determine if teaching the robot in Manual Mode, by a skilled programmer (See Qualification of Personnel in the *Robot Safety Guide*), wearing safety equipment and carrying a pendant, is allowable under local regulations. The E-Stop is said to be "muted" in Manual mode (for the customer E-Stop circuitry, see the figures and tables at the beginning of this section).

The muted capability is useful for a situation where a shutdown must occur if the cell gate is opened in Automatic mode, but you need to open the gate in Manual mode. If the mute gate is opened in Automatic mode, the robot defaults to Manual mode operation when power is re-enabled. In muted mode, the gate can be left open for personnel to work in the robot cell. However, safety is maintained because of the speed restriction.

**WARNING: PERSONAL INJURY RISK**

Whenever possible, manual mode operations should be performed with all personnel outside the workspace.

**CAUTION: PERSONAL INJURY RISK**

If you want the cell gate to always cause a robot shutdown, wire the gate switch contacts in series with the user E-Stop inputs. Do not wire the gate switch into the muted safety gate inputs.

Remote Manual Mode

The Front Panel provides for a Manual Mode circuit. See Remote High Power On/Off Control on page 88 for further details about the customer Remote Manual Mode circuitry.

The Front Panel, or the user-supplied panel, must be incorporated into the robot workcell to provide a “Single Point of Control” (the pendant) when the controller is placed in Manual mode. Certain workcell devices, such as PLCs or conveyors, may need to be turned off when the operating mode switch is set to Manual mode. This is to ensure that the robot controller does not receive commands from devices other than from the pendant, the single point of control.

If the user needs to control the Manual/Automatic mode selection from other control equipment, then a custom splitter cable or complete replacement of the Front Panel may be required. See Front Panel Schematic on page 85. In this situation, a pair of contacts should be wired *in series* with the Front Panel Manual/Automatic mode contacts. Thus, both the Front Panel and the customer contacts need to be closed to allow Automatic mode.

**WARNING: PERSONAL INJURY RISK**

Do not wire user-supplied Manual/Automatic contacts in parallel with the Front Panel switch contact. This would violate the “Single Point of Control” principle and might allow Automatic (high-speed) mode to be selected while an operator is in the cell.

User Manual/Auto Indication

Two pairs of pins on the XUSR connector (pins 9, 22 and 10, 23) provide a voltage-free contact to indicate whether the Front Panel and/or remote Manual/Automatic switches are closed. The user may use these contacts to control other mechanisms (for example, conveyor, linear modules, etc.) when Manual mode is selected. The load on the contacts should not exceed 40 VDC or 30 VAC at a maximum of 1 A.

**WARNING: PERSONAL INJURY RISK**

Any safeguards that were suspended must be returned to full functionality prior to selecting Automatic Mode.

User High Power On Indication

In the optional SmartController EX, eV+ controls a normally-open relay contact on the XDIO connector (pins 45, 46, see the table XDIO Digital I/O Connector Pin Assignments in the SmartController EX manual), that will close when high power has been enabled. The user can use this feature to power an indicator lamp or other device, that signals High Power is On. The limit on these contacts is 1 A at 30 VDC or 30 VAC.

Remote High Power On/Off Control

The easiest and most effective way to provide the high power on/off control in a remote location is to mount the Front Panel in the desired location with an extension cable.

However, if the user needs to control high power on/off from other control equipment or from a location other than the Front Panel, then a custom splitter cable will be required. See the Front Panel schematic (Front Panel Schematic on page 85) for details of the Front Panel's wiring. In this situation, a second momentary contact for high power on/off would be placed *in parallel with* the Front Panel push-button contact. This second contact should be suppressed when in Manual mode (see the note on "Single Point of Control" below).

This method allows relocating the push-button switch to a more convenient location. Implementation of this method must conform to EN standard recommendations.

NOTE: European standards require that the remote High Power push-button be located outside of the workspace of the robot.

Pins 6, 14 and 5, 13 of the XFP connector provide this remote capability. Pins 5, 13 provide power for the lamp, +5 VDC and ground, respectively. Pins 6, 14 are inputs for voltage-free normally-open contacts from a user-supplied momentary push-button switch.



WARNING: PERSONAL INJURY RISK

To fulfill the "Single Point of Control" requirement, do not place the Manual/Automatic and High Power On controls in multiple locations. After putting the robot into Manual mode, the operator should remove the key for safety purposes. The system should not be wired so that a PLC or another operator can put the system back into Automatic mode.

High Power On/Off Lamp

The Front Panel High Power On/Off Lamp (p/n: 27400-29006) will cause an error, from eV+, if the lamp burns out. This error prevents High Power from being turned on. This safety feature prevents a user from not realizing that High Power is enabled because the High Power indicator is burned out. See Changing the Lamp in the Front Panel High-Power Indicator on page 112 for information on changing this lamp.

Remote Front Panel or User-Supplied Control Panel Usage

Users can mount the Front Panel remotely by using an extension cable or by wiring a user-supplied Front Panel (control panel) to the controller using the 15-pin XFP connector. The Front Panel contains no active components, only switches and lights. Customers should be able to adapt the Front Panel's functionality into their own Front Panel design. To automatically control the Front Panel's signals, use relay contacts instead of switches. See the figure Front Panel

Schematic on page 85 for a schematic drawing of the Front Panel, and see the table System Installation on page 57 for a summary of connections and pin numbers.

NOTE: The system was evaluated by Underwriters Laboratory with our Front Panel. If you provide a substitute front panel, the system may no longer be UL compliant.

Users can build an extension cable to place the Front Panel in a remote location. The extension cable must conform to the following specifications:

- Wire Size: must be larger than 26 AWG.
- Connectors: must be 15-pin, standard D-sub male and female.
- Maximum cable length is 10 meters.

NOTE: The XMCP and XFP connectors can be interchanged without electrical damage. However, neither the Front Panel nor the pendant will work properly unless they are plugged into the correct connector.

Remote Pendant Usage

Customers can build an extension cable to place the pendant in a remote location. The extension cable must conform to the following specifications:

- Wire Size: must be larger than 26 AWG.
- Connectors: must be 15-pin, standard D-sub male and female.
- Maximum cable length is 10 meters.



CAUTION: PERSONAL INJURY OR PROPERTY DAMAGE RISK
Do not modify the cable that is attached to the pendant. This could cause unpredictable behavior from the robot system.

Chapter 6: System Operation

6.1 Status Panel Codes

The status panel display on the eMB-40/60R displays alpha-numeric codes that indicate the operating status of the robot, including detailed fault codes. The chapter on eMotionBlox-40/60R gives definitions of the fault codes. These codes provide details for quickly isolating problems during troubleshooting. See Status Panel on page 42.

6.2 Brakes

UL robots have an integrated brake-release switch located on the robot. On non-UL robots, you can install a manual brake-release box. In both cases, you can release the brakes on a specific joint.



WARNING: Pressing the Brake Release button may cause robot arms and the tool flange to fall.

Secure the robot prior to releasing the brakes on joints 2 or 3, to prevent injury to personnel or equipment damage.

Installing and Using the Brake Release Box

This procedure describes how to install and use a manual brake release box on non-UL robots. See the following figure.

1. Make sure that high power is disabled (off).
2. Connect the 9-pin male D-sub connector into the 9-pin female D-sub connector marked Brake on the eMB-40/60R.
3. Press one of the E-Stops (Pendant, Front Panel, or external).

NOTE: An E-Stop must be activated in order for the brake release box to work.

4. Using the joint selector switch, select the joint for which you want to release the brake.
5. Depress the Brake Release push button to release the brake.
6. Repeat steps 4 and 5 above for releasing the brake on another joint.

NOTE: When the Status LED (Green) is on, it indicates that the circuit is enabled, when the Brake Release push button is pressed.

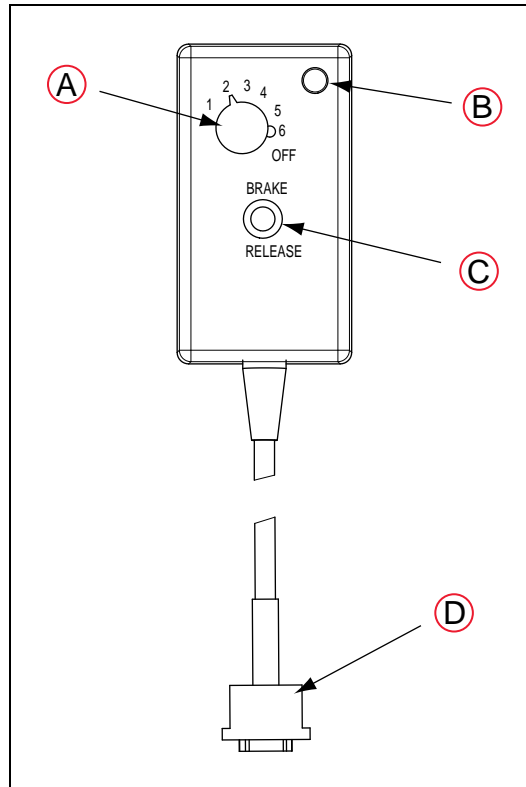

Figure 6-1. Manual Brake-Release Box

Key	Meaning
A	Joint selector switch
B	Status LED
C	Brake Release Push Button
D	9-pin male D-Sub connector

Using the Brake Release Switch on UL Robots

This procedure describes how to use the brake release switch on the base of UL robots. See the following figure.

1. Make sure that high power is disabled (off).
2. Press one of the E-Stops (Pendant, Front Panel, or external).

NOTE: An E-Stop must be activated in order for the brake release to work.

3. Using the joint selector switch, select the joint for which you want to release the brake.
4. Depress the Brake Release push button to release the brake.
5. Repeat steps 3 and 4 above to release the brake on another joint.

NOTE: When the Status LED (Green) is on, it indicates that the circuit is enabled, when the Brake Release push button is pressed.



Figure 6-2. Brake Release Switch on UL Robots

6.3 Front Panel

NOTE: The factory-supplied Front Panel E-Stop is designed in accordance with the requirements of IEC 60204-1 and ISO 13849.



WARNING: PERSONAL INJURY RISK

Any user-supplied front panel E-Stop must be designed in accordance with the requirements of IEC 60204-1 and ISO 13849. The push button of the E-Stop must comply with ISO 13850 (Clause 5.5.2).

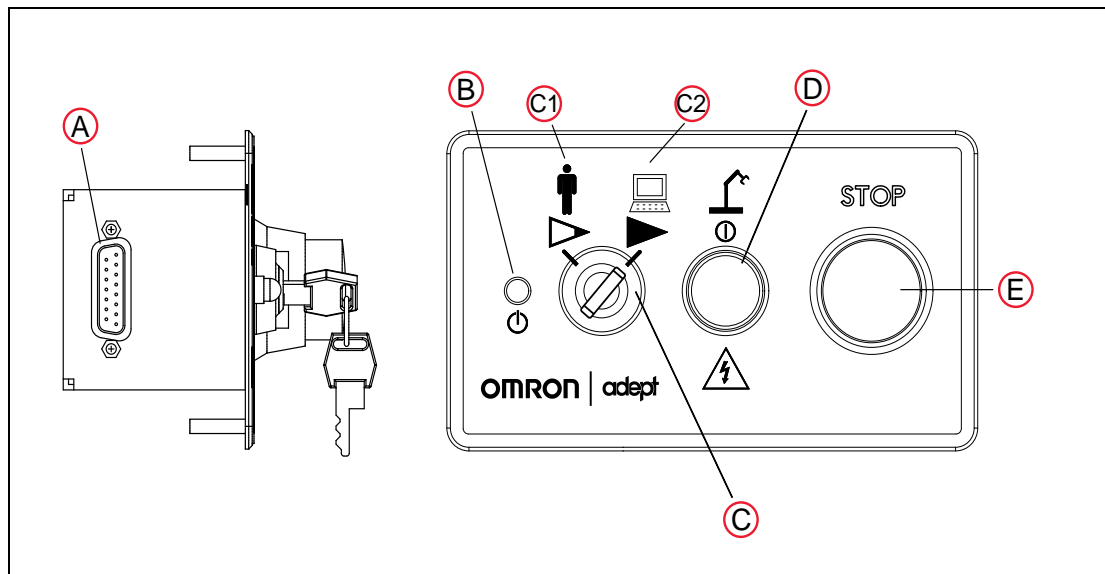

Figure 6-3. Front Panel

A. XFP connector

Connects to the XFP connector on the eAIB XSYSTEM cable (or the optional SmartController EX, if one is being used).

B. System 5 V Power-On LED

Indicates whether or not power is connected to the robot.

C. Manual/Automatic Mode Switch

Switches between Manual and Automatic mode. In Automatic mode, executing programs control the robot, and the robot can run at full speed. In Manual mode, the system limits robot speed and torque so that an operator can safely work in the cell. Manual mode initiates hardware and software restrictions on robot speed, commanding no more than 250 mm/sec.

C1. Manual Mode

C2. Auto Mode

There is no high speed mode in manual mode.

**WARNING: PERSONAL INJURY RISK**

If an operator is going to be in the work cell in manual mode, it is strongly recommended that the operator carry an enabling device. The Enable button on the manual control pendant is such a device.

**WARNING: PERSONAL INJURY RISK**

Whenever possible, manual mode operations should be performed with all personnel outside the workspace.

D. High Power On/Off Switch and Lamp

Controls high power, which is the flow of current to the robot motors. Enabling high power is a two-step process. An “Enable Power” request must be sent from the user-supplied PC, an executing program, or a pendant. Once this request has been made and the High Power On/Off lamp/button is blinking, the operator must press and release this button, and high power will be enabled.

NOTE: The use of the blinking High Power button can be configured (or eliminated) in software. Your system may not require this step.

**WARNING: PERSONAL INJURY RISK**

Disabling the High Power button violates IEC 60204-1. It is strongly recommended that you not alter the use of the High Power button.

NOTE: If enabled, the Front Panel button must be pressed while blinking (default time-out is 10 seconds). If the button stops blinking, you must enable power again.

E. Emergency Stop Switch

The E-Stop is a multi-channel, passive E-Stop that supports Category 3 CE safety requirements. Pressing this button turns off high power to the robot motors.

NOTE: The Front Panel must be installed to be able to Enable Power to the robot. To operate without a Front Panel, the user must supply the equivalent circuits.

6.4 Starting the System for the First Time

The first time you power-up the system, you must follow the steps in this section to safely bring up your robot system. The tasks include:

- Verifying installation, to confirm all tasks have been performed correctly.
- Starting up the system by turning on power for the first time.
- Verifying all E-Stops in the system function correctly.
- Moving each joint of the robot (typically with the pendant) to confirm it moves in the proper directions.

Verifying Installation

Verifying that the system is correctly installed and that all safety equipment is working correctly is an important process. Before using the robot, make the following checks to ensure that the robot and controller have been properly installed.



DANGER: PERSONAL INJURY OR PROPERTY DAMAGE RISK
After installing the robot, you must test it before you use it for the first time. Failure to do this could cause death, serious injury or equipment damage.

Mechanical Checks

- Verify that the robot is mounted level and that all fasteners are properly installed and tightened.
- Verify that any end-of-arm tooling is properly installed.
- Verify that all other peripheral equipment is properly installed and in a state where it is safe to turn on power to the robot system.

System Cable Checks

Verify the following connections:

NOTE: The first three connections are made via the eAIB XSYSTEM cable if you are not using an optional SmartController EX motion controller.

- Front Panel to the XSYSTEM on the eMB-40/60R.
- Pendant to the XSYSTEM on the eMB-40/60R.
- XUSR to the XSYSTEM on the eMB-40/60R.
- User-supplied 24 VDC power to the eMB-40/60R 24 VDC connector.
- User-supplied 200/240 VAC power to the eMB-40/60R 200/240 VAC connector.

NOTE: If you are using an optional SmartController EX, you should check the following:

- eAIB XSYS cable between the robot interface panel XSYSTEM connector and XSYS connector on the SmartController, and the latching screws tightened.
- Front Panel to the SmartController EX.
- Optional pendant to the SmartController EX.
- User-supplied 24 VDC power to the controller.
- User-supplied ground wire between the SmartController EX and ground.
- One end of the IEEE 1394 cable into a SmartServo port connector on the SmartController EX, and the other end into a SmartServo connector on the eMB-40/60R.

User-Supplied Safety Equipment Checks

Verify that all user-supplied safety equipment and E-Stop circuits are installed correctly.

System Start-up Procedure

Once the system installation has been verified (see Verifying Installation on page 95), you are ready to start up the system.

1. Switch on AC power to the eMB-40/60R.
2. Switch on the 24 VDC power to the controller (if used) and the eMB-40/60R.
3. Follow the instructions, beginning with Starting the ACE Software, in the following section.

Running the ACE Software

Starting the ACE Software

The robot should be on, and the status panel should display OK before proceeding.

1. Turn on the PC and start the ACE software.
 - Double-click the ACE icon on your Windows desktop or, from the Windows Start menu bar,
 - Select **Start > Programs > Omron > ACE x.y**
x.y where x is the ACE major version, and y is the ACE minor version.
For example, for ACE 3.6, it would be: Start > Programs > Omron > ACE 3.6
2. On the ACE Startup menu, click New SmartController Workspace.
3. Click-select the SmartController you want to use, and click OK.

Enabling High Power

After you have started the ACE software and connected to the controller, enable high power to the robot motors:

1. From the ACE main menu, click the Enable High Power icon: 
2. If the High Power button on the Front Panel is blinking, press and release it.

NOTE: The use of the blinking High Power button can be configured (or eliminated) in software. Your system may not require this step.

The Front Panel, which is mounted just outside the workcell safety barrier, is shown in the following figure. If enabled, the High Power button must be pressed while blinking (default time-out is 10 seconds). If the button stops blinking, you must enable power again.

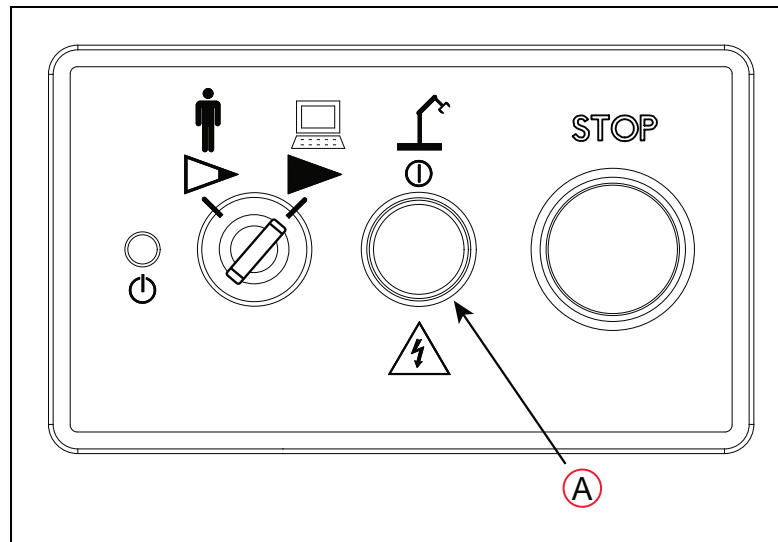

Figure 6-4. High Power Button on Front Panel

Key	Meaning
A	Press High Power Enable Button when Blinking

This step turns on high power to the robot motors and calibrates the robot.

- The amplifier status LED blinks green rapidly (a slow green blink has a different meaning).

In addition, for IP65 Viper robots, the lamps on the robot glow solid amber.

- The status panel on the robot or amplifier chassis displays ON.

Verifying E-Stop Functions

Verify that all E-Stop devices are functional (pendant, Front Panel, and user-supplied). Test each mushroom button, safety gate, light curtain, etc., by enabling high power and then opening the safety device. The High Power push button/light on the Front Panel should go out.

Verify Robot Motions

Use the pendant (or jog control) to test the motion of each joint on the robot to confirm it moves in the proper directions.

Refer to the *T20 Pendant User's Guide* for instructions on using the pendant.

If the optional pendant is not installed in the system, you can move the robot using the Robot Jog Control in the ACE software. For details, see the *ACE User's Guide*.

NOTE: When using a pendant with a Viper robot, the Free mode is disabled for safety reasons.

6.5 Learning to Program the Robot

To learn how to use and program the robot, see the *ACE User's Guide*, which provides information on robot configuration, control and programming through the ACE software “point and click” user interface.

For eV+ programming information, refer to the eV+ user and reference guides.

6.6 Installing Joint Labels

The system includes a set of joint directional labels that can be installed on the robot. See the following table. Also refer to Robot Joint Identification on page 9 for a drawing of the joint identification. The yellow X-Y label can be used to indicate the X and Y axes in the World coordinate system in your workcell.

Table 6-1. Joint and Axes Directional Labels

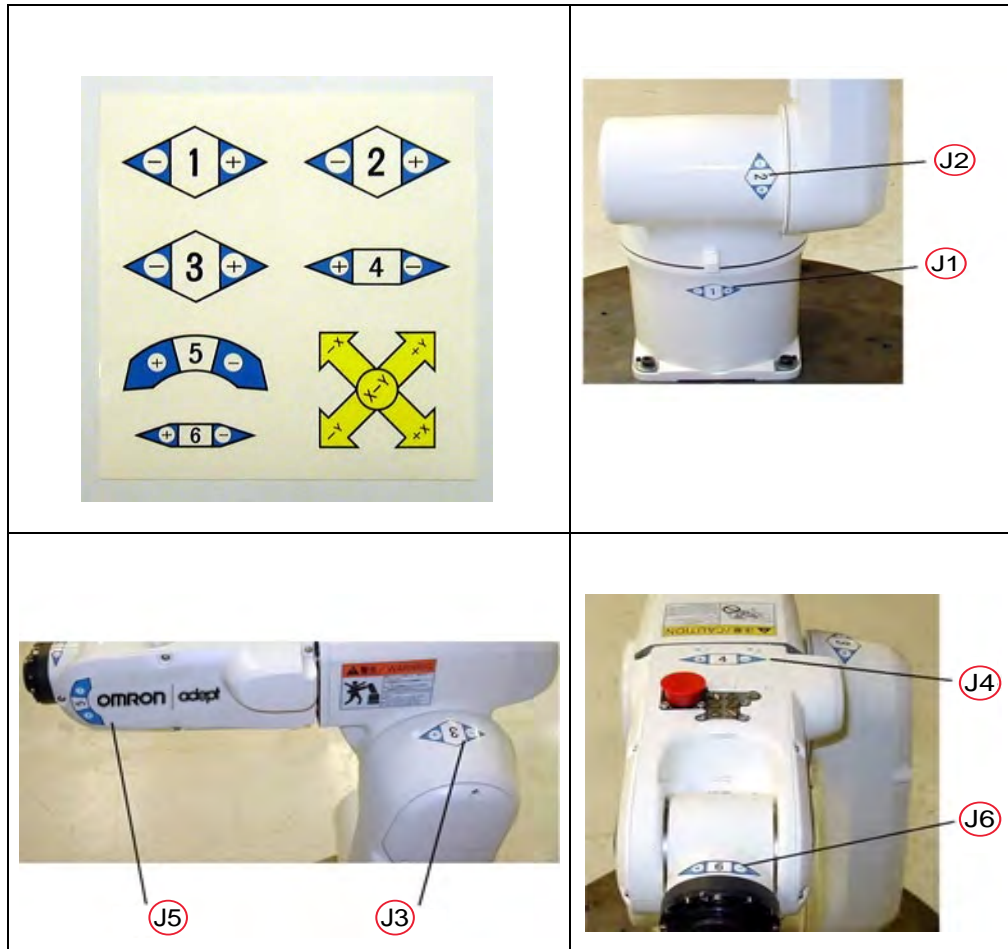

6.7 Caution Label on Robot

The Caution label shown in the following figure refers to rotation of Joint 4. When power is turned off, **do not** manually rotate Joint 4 more than the Joint Limits of $\pm 190^\circ$. If Joint 4 is rotated beyond these limits, the internal wiring can be damaged.



Figure 6-5. Caution Label on Joint 4 Rotation

NOTE: There is no CALSET operation on the Viper robot, and there is no Installation and Maintenance Guide.

Chapter 7: Maintenance

7.1 Field-replaceable Parts



WARNING: PERSONAL INJURY OR PROPERTY DAMAGE RISK
Only qualified service personnel may install or service the robot system. All maintenance work must be performed by skilled and instructed personnel - refer to the Robot Safety Guide. The access covers on the robot are not inter-locked - turn off and disconnect power if covers have to be removed.



WARNING: PERSONAL INJURY RISK
During maintenance, user-supplied fail-safe lock-out measures must be used to prevent unauthorized third parties from turning on power.

This is mandated by Clause 5.2.4 of ISO 10218-1.

The only field-replaceable parts on the Viper 650/850 robots are the encoder battery and the eMB-40/60R.

The part number for the battery is 05234-000.

7.2 Periodic Maintenance Schedule

The following table gives a summary of the preventive maintenance procedures and guidelines on frequency.

Also, for cleanroom robots, see Cleanroom Option on page 133. For IP54/65 robots, see IP54/65 Option on page 129.

Item	Period	Reference
Check E-Stop, enable and key switches, and barrier interlocks	6 months	Checking Safety Systems on page 102
Check robot mounting bolts	6 months	Checking Robot Mounting Bolts on page 102
Replace encoder battery	2 to 7 years	Replacing Encoder Backup Batteries on page 102

NOTE: The frequency of these procedures will depend on the particular system, its operating environment, and amount of usage. Use the times given here as guidelines and modify the schedule as needed.

7.3 Checking Safety Systems

These tests should be done every six months.

1. Test operation of:
 - E-Stop button on Front Panel
 - E-Stop button on pendant
 - Enabling switch on pendant
 - Auto/Manual switch on Front Panel

NOTE: Operating **any** of the above switches should disable high power.

2. Test operation of any external (user-supplied) E-Stop buttons.
3. Test operation of barrier interlocks, etc.

7.4 Checking Robot Mounting Bolts

Check the tightness of the base mounting bolts every 6 months. Tighten to 70 ± 14 N·m (52 ± 10 ft-lbf).

7.5 Replacing Encoder Backup Batteries



CAUTION: Replace the batteries only with 3.6 V, 8.5 Ah lithium batteries, part number: 05234-000. Battery information is located in the base of the robot.

Battery Replacement Intervals

The encoder backup batteries should be replaced according to the intervals that follow.

- If the robot is kept in storage and not in production, or the robot is turned off (no 24 VDC supply) most of the time, then the batteries should be replaced every two years.
- If the robot is turned on with 24 VDC supplied to the robot half the time, the batteries should be replaced every four years.
- If the robot is turned on with 24 VDC more than half the time, then you can increase the replacement interval to seven years. If, for example, a robot is typically turned off only on weekends, the batteries would need to be replaced every seven years.

Battery Replacement Procedure

NOTE: Dispose of the batteries according to all local and national environmental regulations regarding electronic components.

Replace the batteries according to the following procedure:

1. Prepare a new set of three backup batteries for replacement.
2. Turn off AC power to the eMB-40/60R.
3. DC power must be supplied to eMB-40/60R, otherwise encoder data could be lost.
4. Remove the cover from the robot. See the following figure.

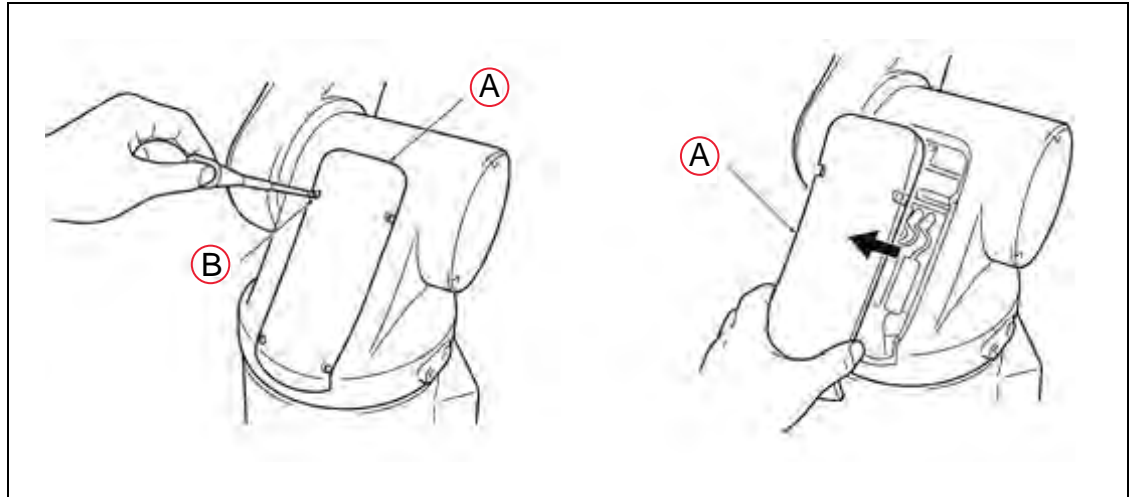

Figure 7-1. Removing Cover to Replace Encoder Batteries

Key	Meaning
A	Cover
B	Cross pan-head screw
	Note: IP54/65 and Cleanroom robots use hex socket-head screws.

5. Remove the dummy connector cap from the battery board. See the following figure.

NOTE: Some robots have PCAs with only three battery connections, therefore, they do not have dummy connectors. For those robots, remove and replace all three batteries one at a time.

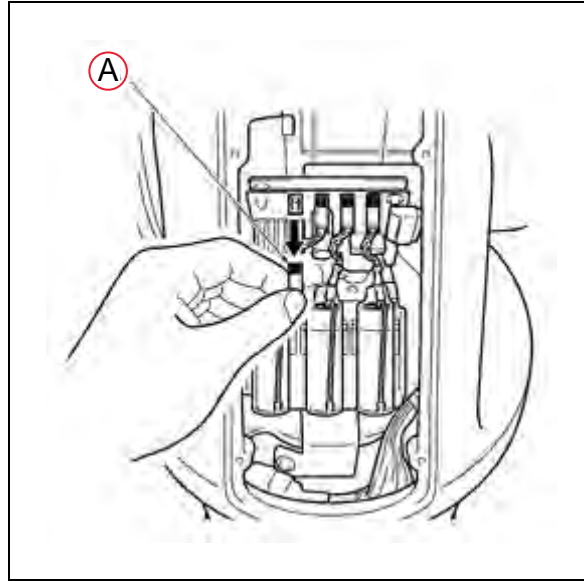

Figure 7-2. Removing (A) Dummy Connector Cap

6. Connect a new battery (1st one) to the pin from which you disconnected the dummy connector cap in the previous step. See the following figure.

NOTE: Do not disconnect the old backup battery before connecting a new one to the pin from which the dummy connector cap is removed. If you do so, the encoder positional data may be lost.

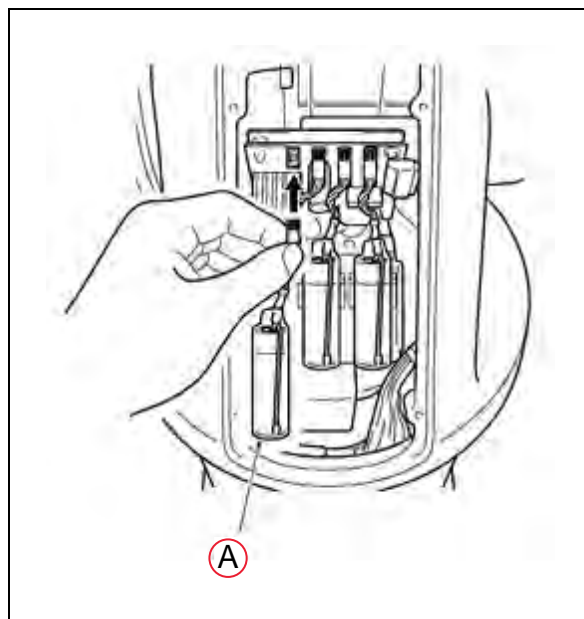

Figure 7-3. Connecting (A) First New Battery

7. Disconnect the old backup battery that is next to the new battery connected in the

previous step, and then connect a new battery (2nd one). See the following figure.

NOTE: Be sure to replace all of three batteries with new ones at one time. Otherwise, the battery service life will be reduced.

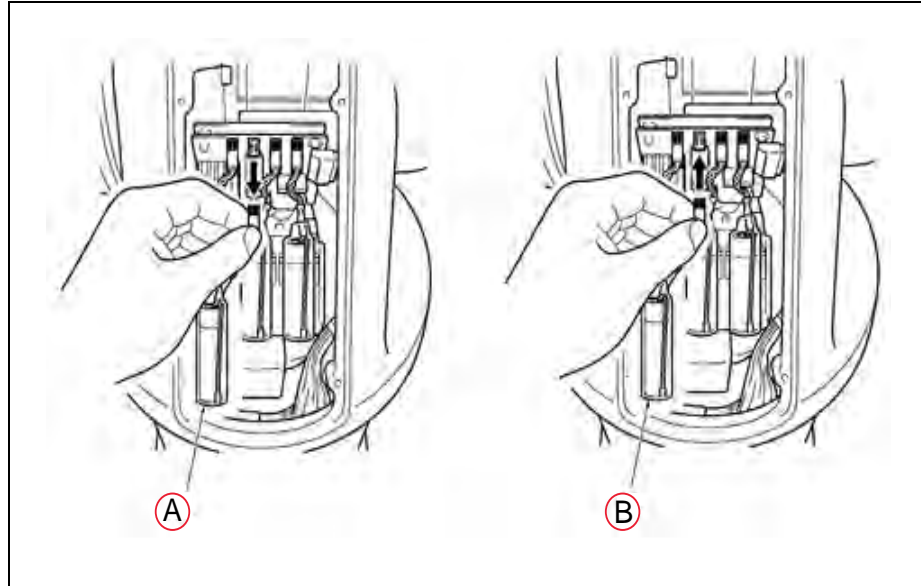

Figure 7-4. Connecting Second New Battery

- A. Old backup
- B. New backup battery

8. Disconnect the old backup battery that is next to the new battery connected in the previous step, and then connect a new battery (3rd one). See the following figure.

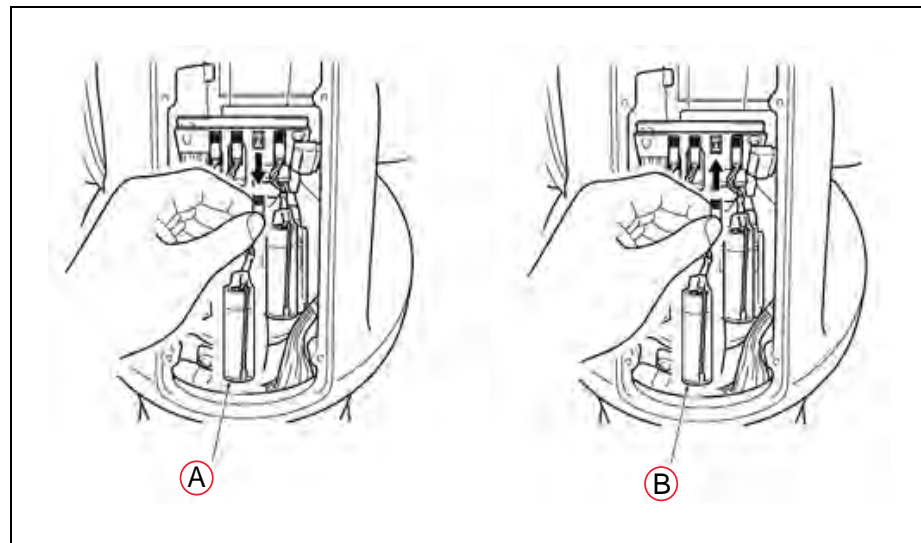

Figure 7-5. Connecting Third New Battery

- A. Old backup
 - B. New backup battery
9. Remove the last old battery and connect the dummy connector cap disconnected in Step 4. See the following figure.

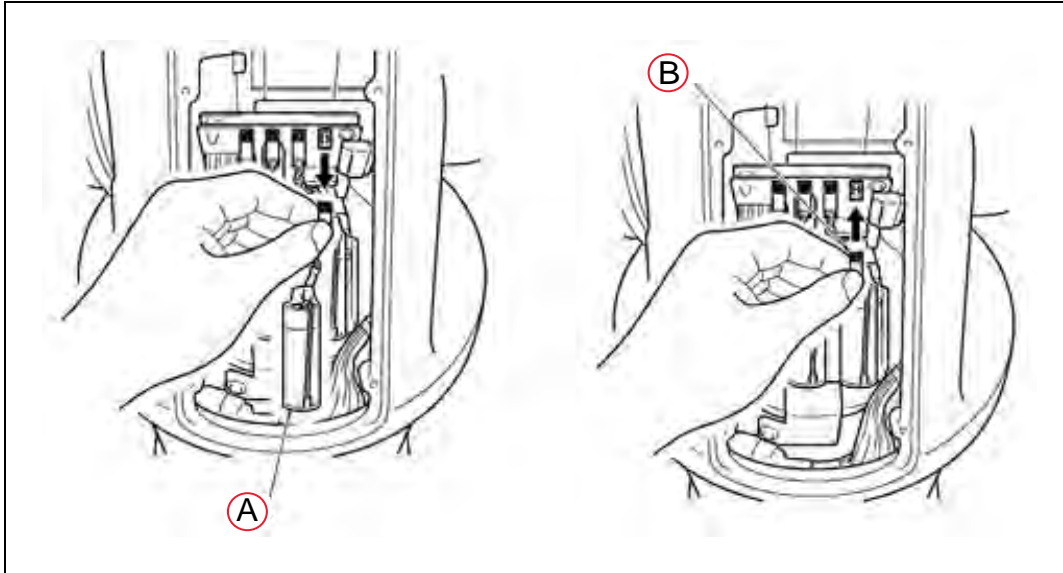

Figure 7-6. Reconnecting Dummy Connector Cap

- A. Old backup
 - B. Dummy connector cap
10. Replace the cover on the robot.
- Tightening torque: IP54/65 models - Hex socket bolt: 2.0 N·m (1.5 ft-lbf)
 - Tightening torque: Standard models - cross pan-head screw: 0.59 N·m (0.4 ft-lbf)

7.6 Replacing the eMB-40/60R Amplifier

Remove the eMB-40/60R Amplifier

1. Switch off the SmartController EX.
2. Switch off the 24 VDC and 200/240 VAC input supplies to the eMB-40/60R.
3. Disconnect the 24 VDC supply cable from the eMB-40/60R +24 VDC connector.
See Connectors on eMB-40/60R Interface Panel on page 40 for locations of connectors.
4. Disconnect the 200/240 VAC supply cable from the eMB-40/60R AC connector.
5. Disconnect the eAIB XSYS cable from the eMB-40/60R XSYSTEM connector.

If the system was upgraded from an MB-40/60R to an eMB-40/60R, you may need to disconnect the XSYS cable and eAIB XSLV Adapter from the XSYSTEM connector.

6. Disconnect the IEEE 1394 cable from the eMB-40/60R SmartServo connector.
7. Disconnect any other cables, which are connected to the eMB-40/60R, such as XIO.

Installing a New eMB-40/60R

1. Carefully remove the new eMB-40/60R from its packaging, check it for any signs of damage, and remove any foreign packing materials or debris.
2. Carefully place the eMB-40/60R next to the robot.
3. Connect the 200/240 VAC supply cable to the eMB-40/60R AC input connector.
4. Connect the eAIB XSYS cable to the eMB-40/60R XSYSTEM connector.

If you are upgrading from an MB-40/60R to an eMB-40/60R, connect the existing XSYS cable to the eAIB XSLV Adapter, which connects to the eMB-40/60R XSYSTEM connector.

5. Connect the IEEE 1394 cable to the eMB-40/60R SmartServo connector.
6. Connect any other cables, which were connected to the eMB-40/60R, such as XIO.
7. Connect the 24 VDC supply cable to the eMB-40/60R +24 VDC input connector.
8. Switch on the 200/240 VAC input supply to the eMB-40/60R.
9. Switch on the 24 VDC input supply to the eMB-40/60R.
10. Switch on the SmartController EX.
11. Once the system has completed booting:
 - Verify that the new eMB-40/60R has been commissioned. The initial commissioning utility screen will tell you which functions are commissioned. Refer to Commissioning Status on page 108.
 - Test the system for proper operation.

7.7 Commissioning a System with an eMB-40/60R

Commissioning a system involves synchronizing the robot with the eMB-40/60R.

NOTE: This section only applies to robots that have an eMB-40/60R amplifier. A robot with an MB-40/60R amplifier does not need the ACE commissioning.

For a new system with an eMB-40/60R, the robot and the eMB-40/60R will have been commissioned at the factory and should not need commissioning.

If you are replacing an MB-40/60R with an eMB-40/60R, you will need to commission the system.

In rare cases with a new robot with an eMB-40/60R, you may need to commission the system.

- If the system will not power up, and the robot status display shows SE, you need to commission the system.

- If the system will not power up in Manual mode, and the robot status display shows TR, you need to commission the system.

Safety Commissioning Utilities

The eMB-40/60R adds two functions that implement safety in hardware:

- **E-Stop** serves as a backup to the standard software E-Stop process. The system will always try to stop the robot using the software E-Stop first. The hardware E-Stop will take over in the event of a failure of the software E-Stop.
- **Teach Restrict** limits the maximum speed of the robot when it is operated in Manual mode. As with the E-Stop, this is a hardware backup to software limits on robot speed. If the software fails to limit the robot speed during manual operation, the hardware Teach Restrict will disable power to the system.

These two functions are only in the eMB-40/60R amplifiers. They were not implemented in hardware in the MB-40/60R amplifiers, so these utilities do not apply to those amplifiers.

These two functions are supported by four wizards:

- E-Stop Configuration
This sets the E-Stop hardware delay to factory specifications.
- E-Stop Verification
This verifies that the hardware E-Stop is functioning correctly.
- Teach Restrict Configuration
This sets the hardware Teach Restrict maximum speed to factory specifications.
- Teach Restrict Verification
This verifies that the hardware Teach Restrict is functioning correctly.

Commissioning Status

The initial utility screen will tell you which functions are commissioned. If a function is not commissioned, its verification wizard will not be displayed. Any displayed verification wizard can be run at any time, to ensure that its function is working properly.

Prerequisites

- The robot must be set up and functional.
- The robot must use eMB-40/60R amplifiers.
The MB-40/60R amplifiers do not support these hardware functions, and these wizards will not run.
- A PC with ACE software version 3.3.2.10 or later must be connected to the eMB-40/60R.
- The Front Panel keyswitch must be in Auto mode. See (A) in following graphic.

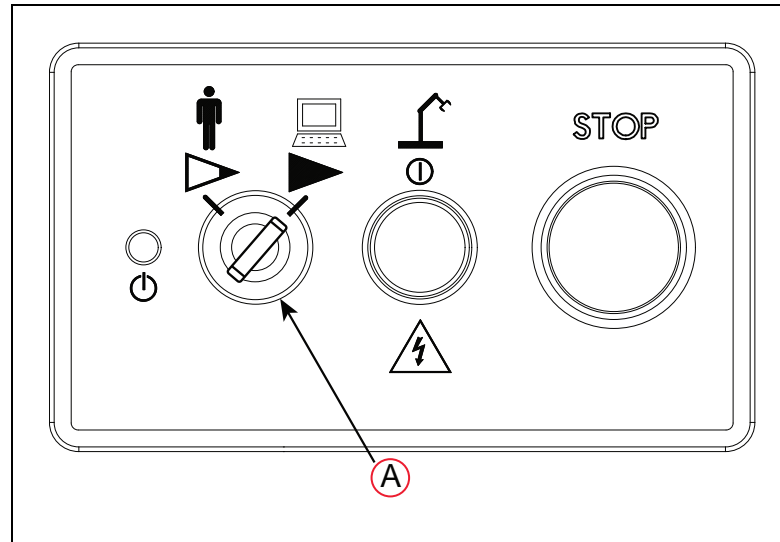

Figure 7-7. Front Panel

- A manual control pendant is required for the Teach Restrict verification.
- No E-Stops can be activated.
- For Configuration (E-Stop and Teach Restrict), the eAIB Commissioning Jumper must be plugged into the XBELTIO jack on the eMB-40/60R.

NOTE: This is the only time that this jumper will be used. It is part number 11901-000, and must be removed for Verification and normal operation.



Figure 7-8. eAIB Commissioning Jumper

E-Stop Configuration Utility

This utility sets the E-Stop hardware delay to factory specifications.

NOTE: Ensure that the commissioning jumper is plugged into the XBELTIO jack on the eMB-40/60R before you start this procedure.

Procedure

From within the ACE software:

1. Open the robot object editor.
Double-click on the robot object in the tree structure, usually the left pane.
2. Select **Configure > Safety Settings > Configure ESTOP Hardware Delay**, then click Next.
This procedure will configure Channel A and then Channel B.
It will then report the delay that it set for each.
3. If the SmartController does not reboot, cycle power on the SmartController.
4. Cycle power on the eMB-40/60R.

E-Stop Verification Utility

This utility verifies that the hardware E-Stop parameters are set correctly and that the hardware E-Stop is working.

The hardware E-Stop must have already been configured for this wizard to run.

NOTE: If the commissioning jumper is plugged into the XBELTIO jack on the eMB-40/60R, remove it before you start this procedure.

Procedure

From within the ACE software:

1. Open the robot object editor.
Double-click on the robot object in the tree structure, usually the left pane.
2. Select **Configure > Safety Settings > Verify ESTOP Hardware Delay**, then click Next.
3. Enable high power, if not already enabled, then click Next.
4. Press an E-Stop button (on the Front Panel), then click Next.
The utility will confirm that the hardware delay has been verified for this robot, and display the delay times for channels A and B.
5. If the SmartController does not reboot, cycle power on the SmartController.

Teach Restrict Configuration Utility

This utility sets the hardware Teach Restrict maximum speed parameter to factory specifications.

NOTE: Ensure that the commissioning jumper is plugged into the XBELTIO jack on the eMB-40/60R before you start this procedure.

Procedure

NOTE: This procedure takes 2 or 3 minutes to complete.

From within the ACE software:

1. Open the robot object editor.
Double-click on the robot object in the tree structure, usually the left pane.
2. Select **Configure > Safety Settings > Configure Teach Restrict**, then click Next.
3. From the Prerequisite screen, click Next.

The wizard will go through all of the robot's motors, and display messages that it is configuring Channel A and B for each.

It will then record the configuration, and display the target times that it set.

4. Click Finish.
5. If the SmartController does not reboot, cycle power on the SmartController.

Teach Restrict Verification Utility

This utility verifies that the Teach Restrict parameters are set correctly and that the hardware Teach Restrict maximum speed control is working.

This is a two-part wizard. The first is run in Auto mode. The second is run in Manual mode.

Before running this verification utility, the Teach Restrict must be configured.

NOTE: If the commissioning jumper is plugged into the XBELTIO jack on the eMB-40/60R, remove it before you start this procedure.

Automatic Mode Procedure



WARNING: The robot will move during this wizard. Ensure that personnel stay clear of the robot work area.

From within the ACE software:

1. Open the robot object editor.
Double-click on the robot object in the tree structure, usually the left pane.
2. Select **Configure > Safety Settings > Verify Teach Restrict**, then click Next.
3. Teach a Start Position.

NOTE: This procedure will move the robot approximately ± 5 degrees from the starting point of each joint.

This can be any position that does not conflict with obstacles or the limits of joint movements.

- If the robot is already in such a position, you can just click Next.
 - Otherwise, move the robot to such a position, then click Next.
 - The screen will display the number of degrees that each joint is expected to move during the verification process.
 - You can click Preview Motions on this screen to view the motions at slow speed. The default speed is 10, but you can change that speed with this screen's speed control.
 - You can click Move to Ready, to move the robot to the Ready position.
The robot will move each joint, in succession. It will generate an over-speed condition for each, and verify that the hardware detected the over-speed condition.
4. Click Next, to proceed to the Manual Mode Procedure.

If the Automatic Mode Procedure fails, you will not be allowed to proceed with the Manual Mode.

Manual Mode Procedure

The manual mode of this verification requires the use of a manual control pendant.

For this verification, the Front Panel keyswitch must be in Manual mode.

1. From the Introduction screen, click Next.
 - Set the pendant to Joint mode.
 - Set the pendant manual control speed to 100.
2. Click Next.
3. Using the pendant, jog any of the robot's joints until power is disabled.
This indicates that the Teach Restrict function is working.
4. Click Next.
The results of the verification will be displayed.
5. Click Finish.
6. If the SmartController does not reboot, cycle power on the SmartController.
7. Reset the Front Panel keyswitch to Auto mode.

7.8 Changing the Lamp in the Front Panel High-Power Indicator

The system is equipped with circuitry to detect the potentially dangerous condition of a burned-out High Power indicator on the Front Panel. If this lamp is burned out, you cannot enable high power until the lamp has been replaced. Follow this procedure to replace the High Power indicator lamp. The part number for the lamp is 27400-29006.



WARNING: ELECTROCUTION RISK
Lockout and tagout power before servicing.

**WARNING: ELECTROCUTION RISK**

The procedures and replacement of parts mentioned in this section should be performed only by trained, authorized personnel. The access covers on the Front Panel are not interlocked – turn off and disconnect power before removing the cover.

1. Turn off system power to the robot.
2. Turn off power to the optional SmartController EX, if you are using one.
3. Disconnect the cable between the Front Panel and the eMB-40/60R (or controller).
4. Remove the Front Panel from its mounting location.
5. Remove the two screws on the back of the Front Panel.

Save the screws for re-installation.

6. Carefully pull the front cover away from the body of the Front Panel.

You will encounter some resistance, as there are three plug-type connectors that you need to disconnect as you pull the front cover away from the body.

NOTE: Separate the cover from the body slowly to avoid damaging the two wires that go between the LED and the PC board inside the body. Pull the front cover as straight out as possible. You do not have to disconnect the wires from the PC board, although you can if needed.

7. Locate the lamp body in the center of the back side of the front cover. Turn the lamp body approximately 20° in either direction and then pull straight back.
8. The lamp body is now free. You can remove the old lamp and insert a new one.
9. Re-install the lamp body by pushing it straight into the lamp housing receptacle. Make sure the contacts on the lamp body are properly oriented, as shown in the following figure.
10. Make sure to reconnect the wires from the LED if you disconnected them earlier.
11. Push the front cover into the body, taking care to align all of the plug-type connectors. Verify that the wires do not get crimped as you reinstall the cover.
12. Re-install the two screws on the back of the body.
13. Re-install the Front Panel in its mounting.
14. Reconnect the cable between the Front Panel and the eMB-40/60R (or controller).

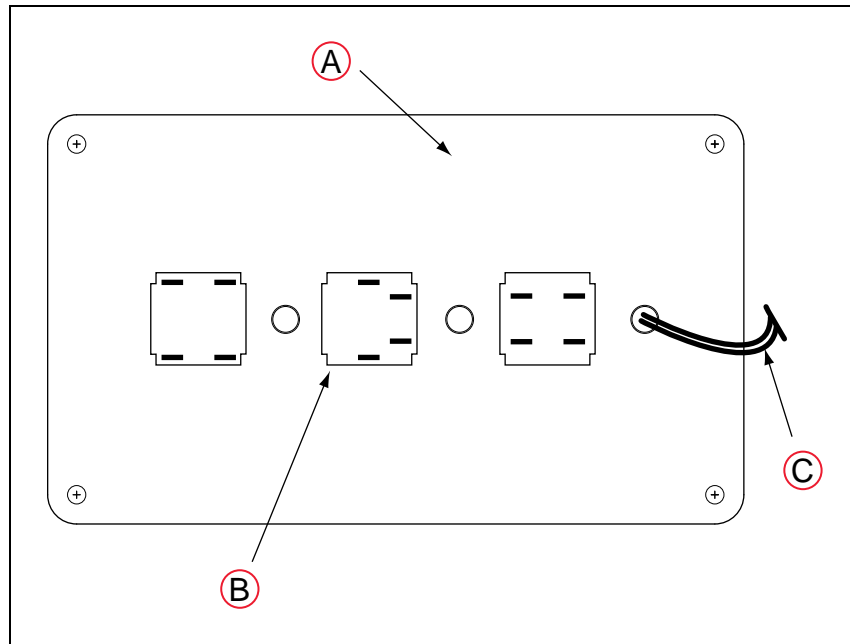

Figure 7-9. Lamp Body Contact Alignment

Key	Meaning
A	Back side of front cover
B	High Power On/Off Lamp Body
C	Wires between LED and body of Front Panel. Be careful when separating front cover from body to avoid damaging the wires.

Chapter 8: Technical Specifications

8.1 Robot Dimensions

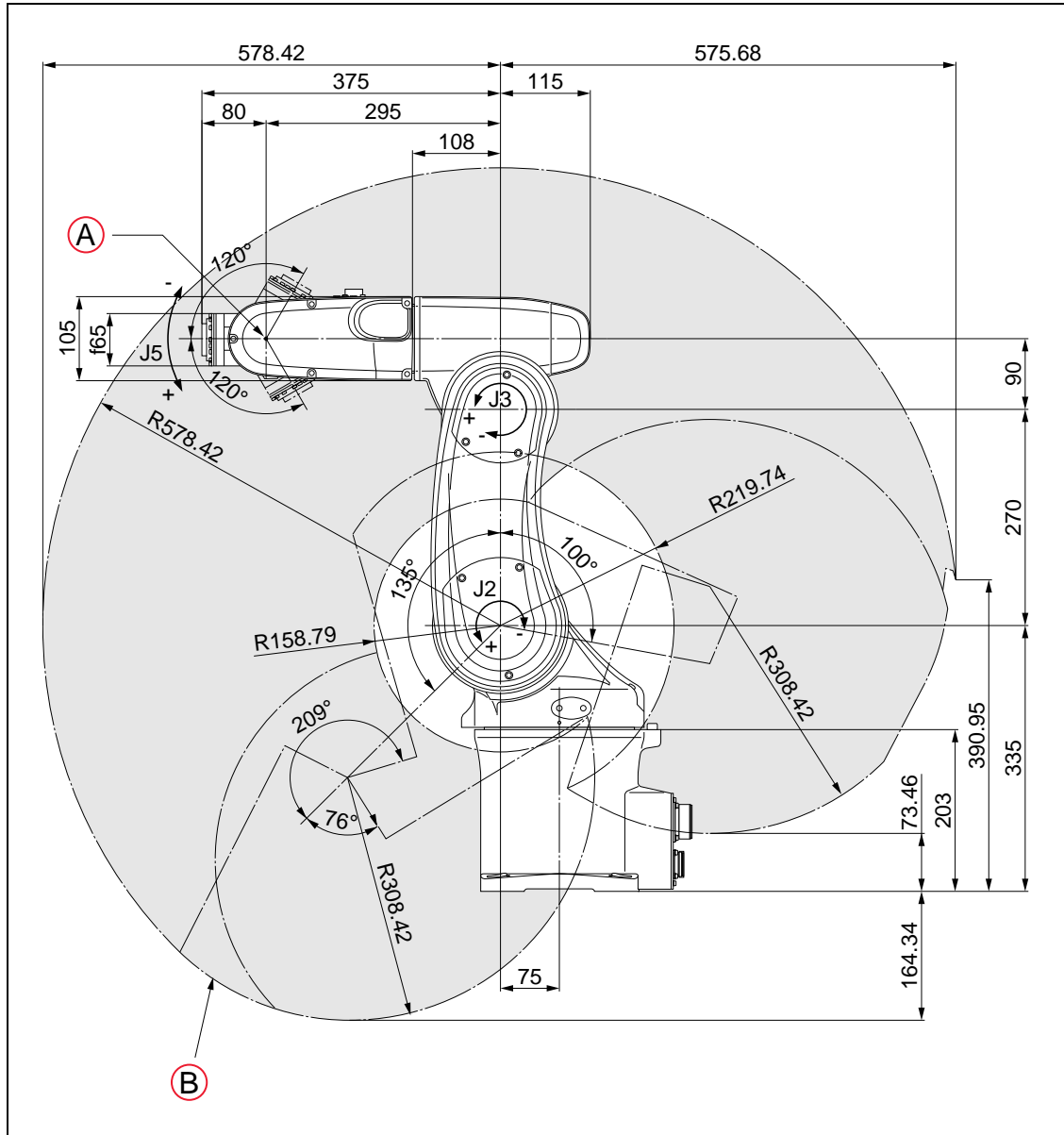

Figure 8-1. Viper 650 Side Dimensions and Work Envelope. Units are mm.

Key	Meaning	Key	Meaning
A	Point P	B	Workable space defined by point P

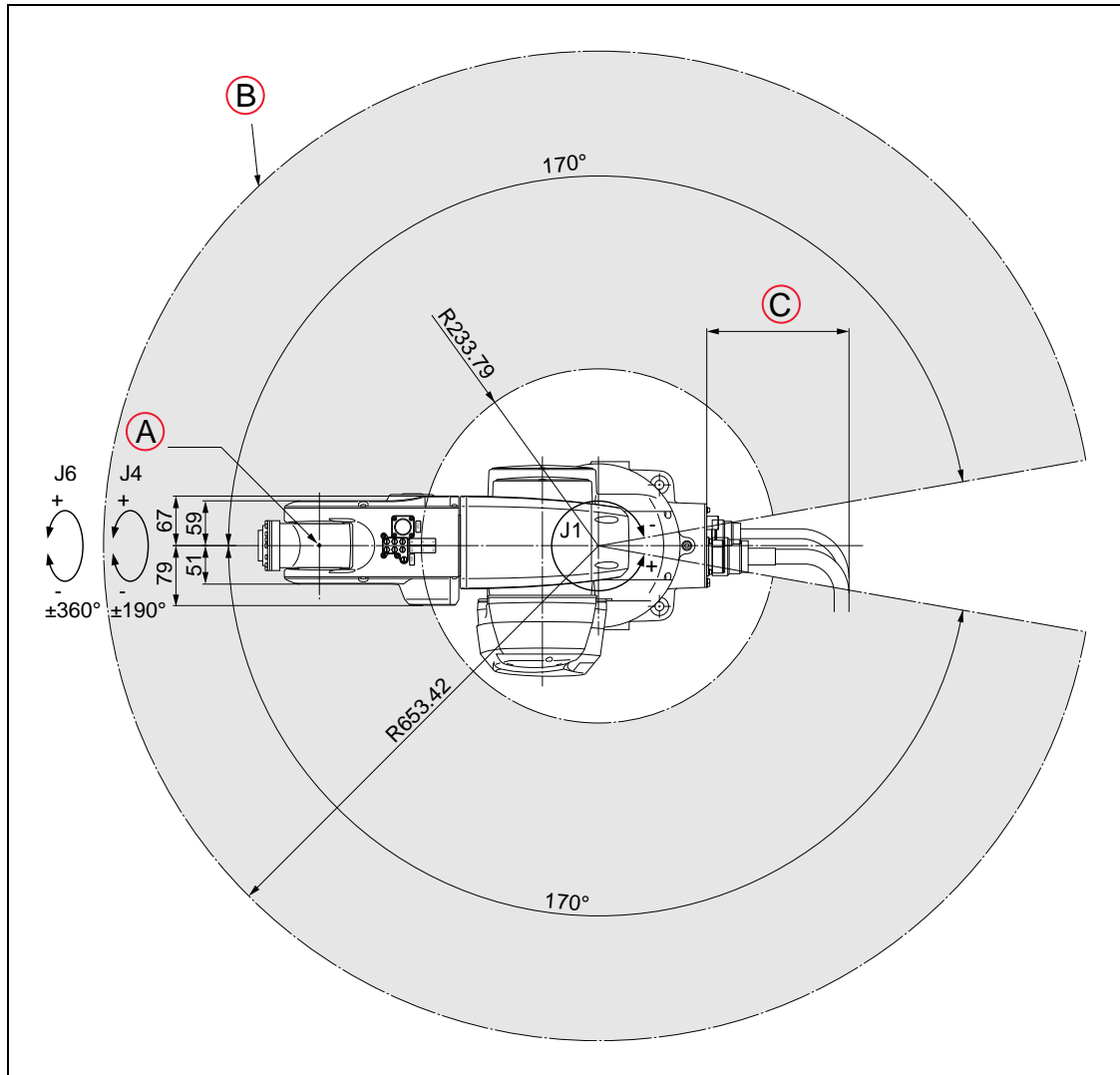

Figure 8-2. Viper 650 Top Dimensions and Work Envelope. Units are mm.

Key	Meaning
A	Point P
B	Workable space defined by point P
C	187.7 (standard cable clearance) 222 (IP54/65 and Cleanroom)

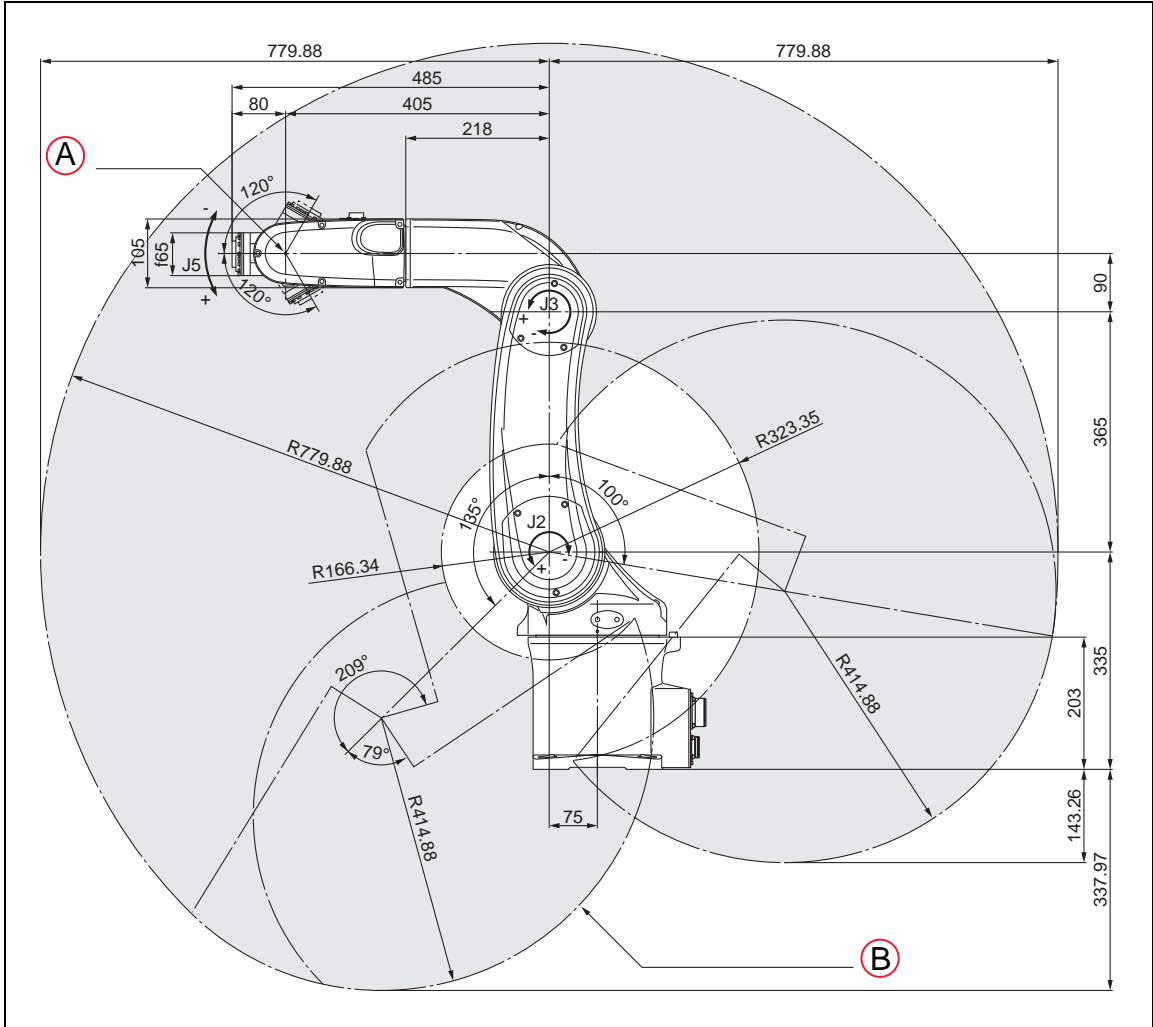

Figure 8-3. Viper 850 Side Dimensions and Work Envelope. Units are mm.

Key	Meaning	Key	Meaning
A	Point P	B	Workable space defined by point P

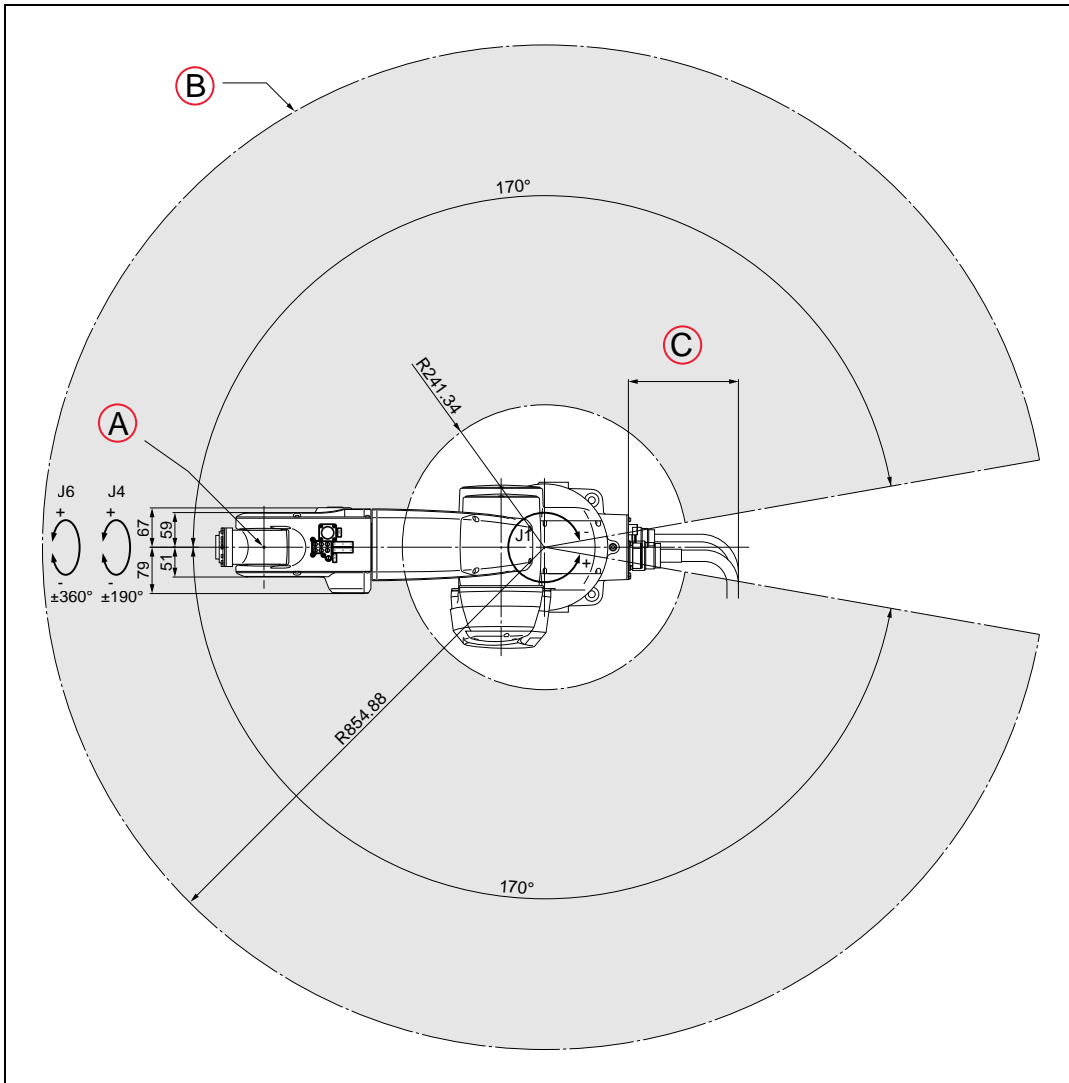

Figure 8-4. Viper 850 Top Dimensions and Work Envelope. Units are mm.

Key	Meaning
A	Point P
B	Workable space defined by point P
C	187.7 (standard cable clearance) 222 (IP54/65 and Cleanroom)

NOTE: Dimension drawings for the eMB-40/60R are shown in Dimensions and Mounting Holes on page 54.

8.2 Robot Flange Dimensions

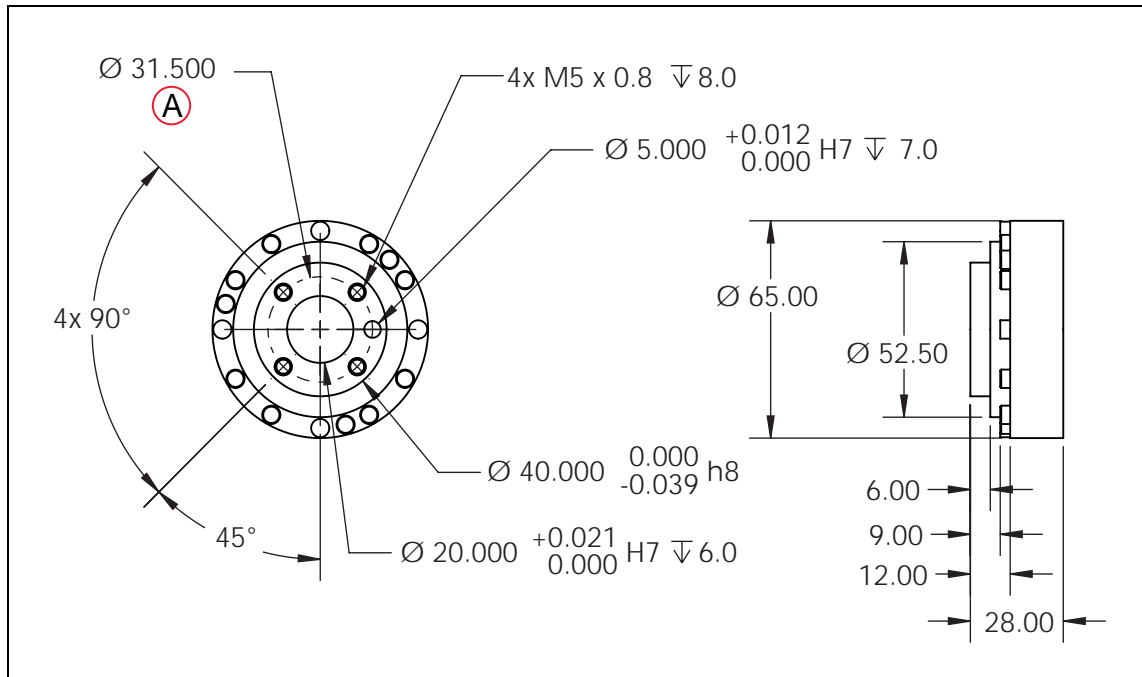

Figure 8-5. Robot Flange Dimensions. (A) Bolt Circle. Units are mm.

Tolerances, if not specified:

1 Place Decimals: ± 0.50

2 Place Decimals: ± 0.10

3 Place Decimals: ± 0.05

Angular Dimensions: $\pm 0.5^\circ$

8.3 Specifications

Physical

Table 8-1. Robot Specifications

Specification	Viper 650	Viper 850
Overall arm length	270 (first link) + 295 (second link) = 565 mm	365 (first link) + 405 (second link) = 770 mm
Arm offset	J1 (swing): 75 mm, J3 (front link): 90 mm	
Maximum motion area	R = 733 mm (end-effector mounting face) R = 653 mm (Point P: J4, J5, J6 center)	R = 934 mm (end-effector mounting face) R = 854 mm (Point P: J4, J5, J6 center)
Motion range	J1: $\pm 170^\circ$ J2: $-190^\circ, +45^\circ$ J3: $-29^\circ, +256^\circ$ J4: $\pm 190^\circ$ J5: $\pm 120^\circ$ J6: $\pm 360^\circ$	
Position detection	Simplified absolute encoder	Simplified absolute encoder
Drive motor and brake	AC servomotors for all joints, Brakes for joints J2 to J6	
User air lines (Note 1)	7 systems ($\varnothing 4 \times 6, \varnothing 6 \times 1$), 3 solenoid valves (2-position, double solenoid) contained.	
User signal line	10 (for proximity sensor signals, etc.)	
Air source - Operating pressure	0.1 to 3.9 MPa (14.5 to 56.6 psi)	
Air source - Maximum allowable pressure	0.49 MPa (71.1 psi)	
Degree of Protection	IP40 (IP54/65 w/ option)	IP40 (IP54/65 w/ option)
Weight	Approx. 34 kg	Approx. 36 kg
Note 1: Only the $\varnothing 4 \times 6$ air tubing system may be controlled by built-in solenoid valves.		

Performance

Specification	Viper 650	Viper 850
Maximum joint speed	J1: 328°/sec J2: 300°/sec J3: 375°/sec J4: 375°/sec J5: 375°/sec J6: 600°/sec	J1: 250°/sec J2: 250°/sec J3: 250°/sec J4: 375°/sec J5: 375°/sec J6: 600°/sec
Maximum composite speed (at the center of an end-effector mounting face)	8200 mm/s	7600 mm/s
Maximum payload	5 kg	
Position repeatability (Note 2)	In each of X, Y and Z directions: ± 0.02 mm	In each of X, Y and Z directions: ± 0.03 mm
Maximum allowable inertia moment	Around J4: 0.295 kgm^2 Around J5: 0.295 kgm^2 Around J6: 0.045 kgm^2	
Note 2: Position repeatability is the value at constant ambient temperature.		

Stopping Distances and Times

NOTE: Where lines overlap (and might not be visible), differences are not significant.

Key to Graphs

Item	Meaning
Blue line	33% max. Payload
Red line	66% max. Payload
Green line	100% max. Payload
A	Stopping Time in s
B	Stopping Distance in degrees
C	Speed as %

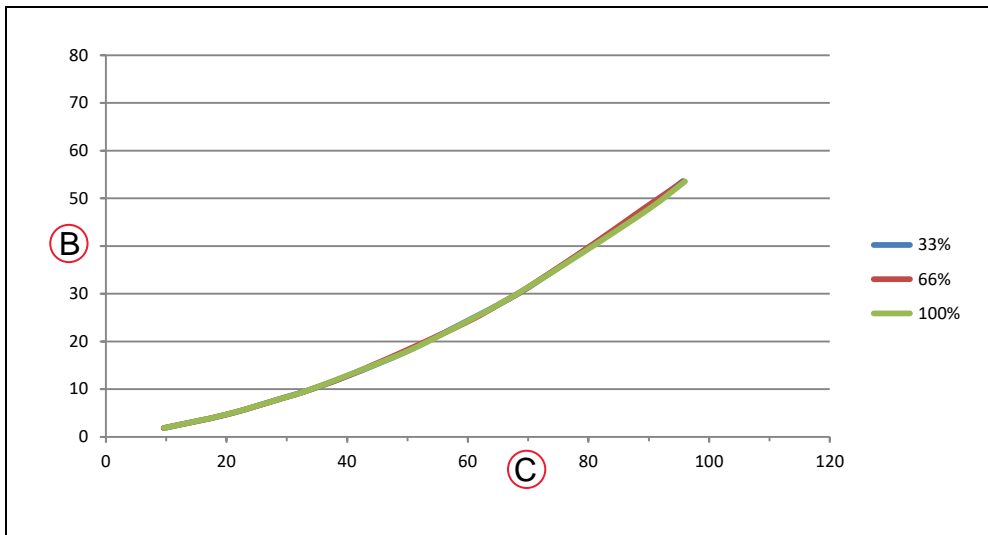

Figure 8-6. Joint 1 Stopping Distance for Viper 650, in Degrees

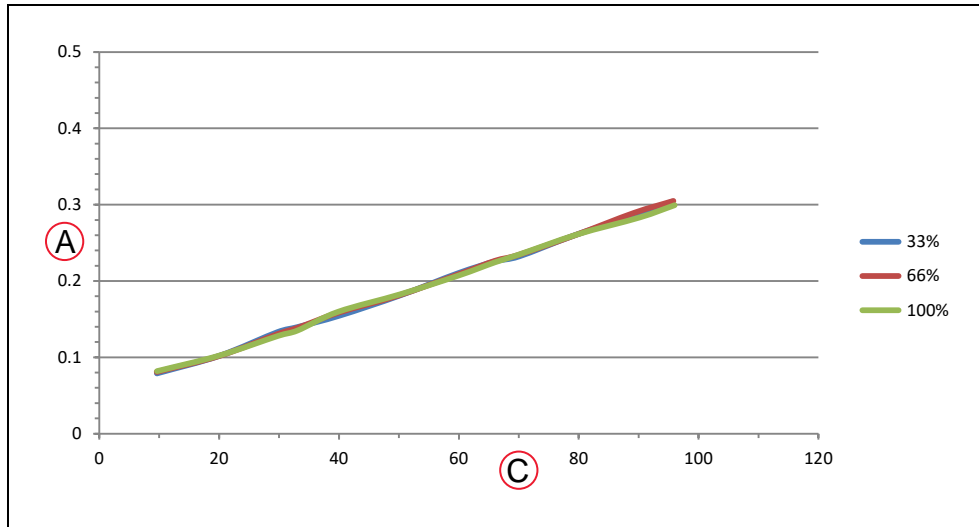

Figure 8-7. Joint 1 Stopping Time for Viper 650, in Seconds

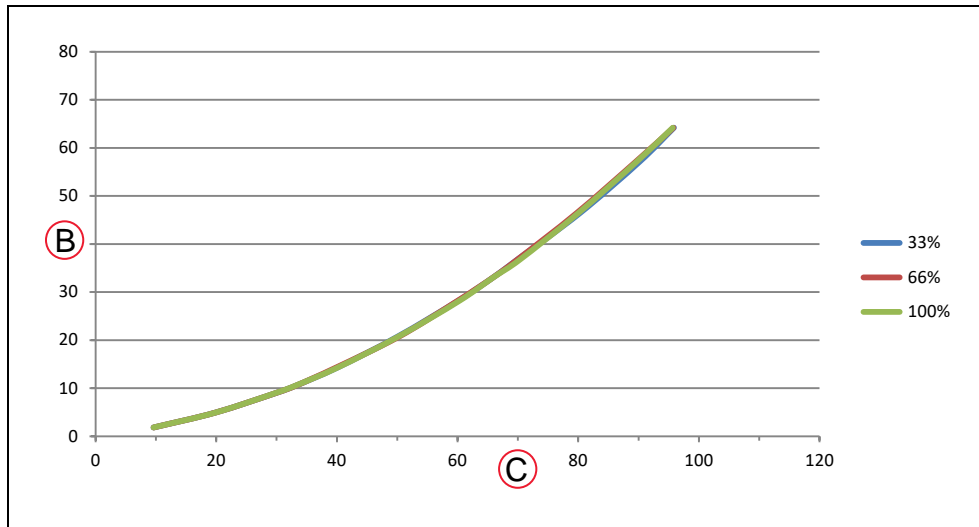

Figure 8-8. Joint 2 Stopping Distance for Viper 650, in Degrees

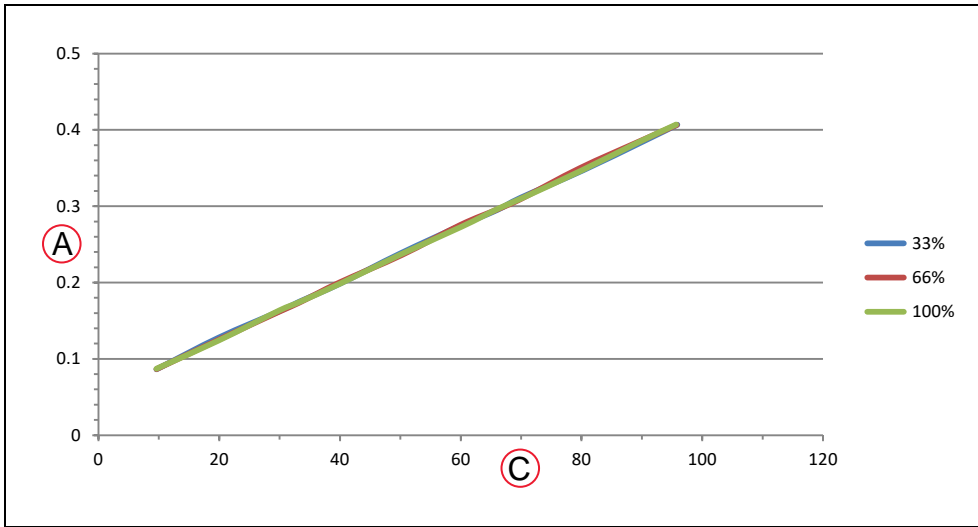

Figure 8-9. Joint 2 Stopping Time for Viper 650, in Seconds

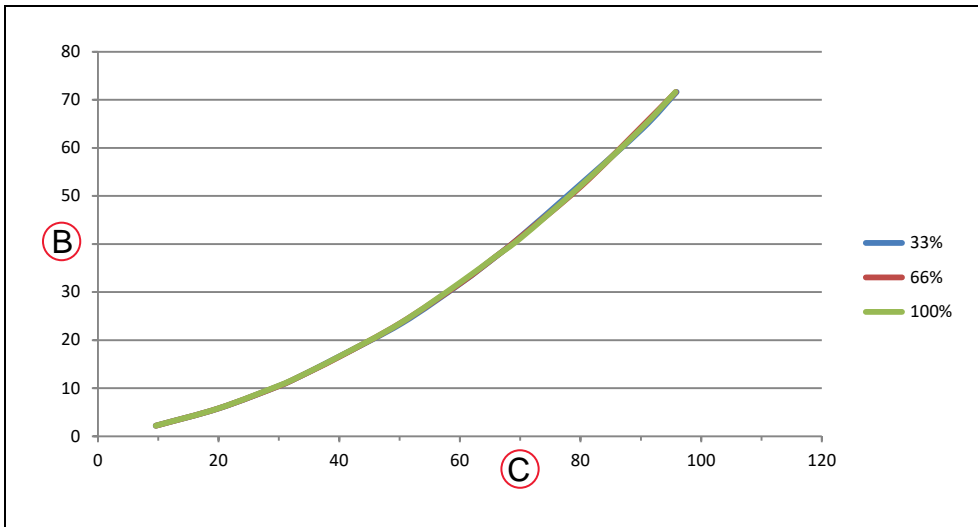

Figure 8-10. Joint 3 Stopping Distance for Viper 650, in Degrees

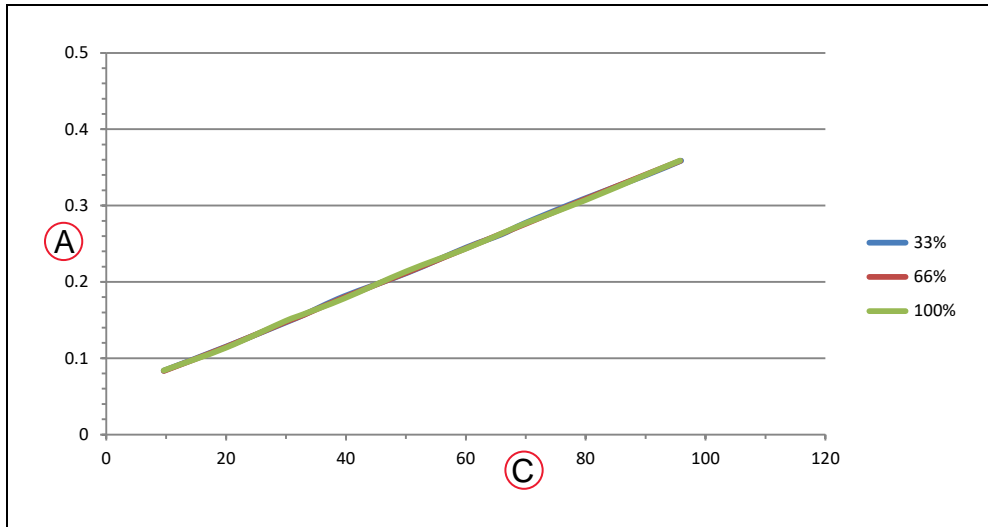

Figure 8-11. Joint 3 Stopping Time for Viper 650, in Seconds

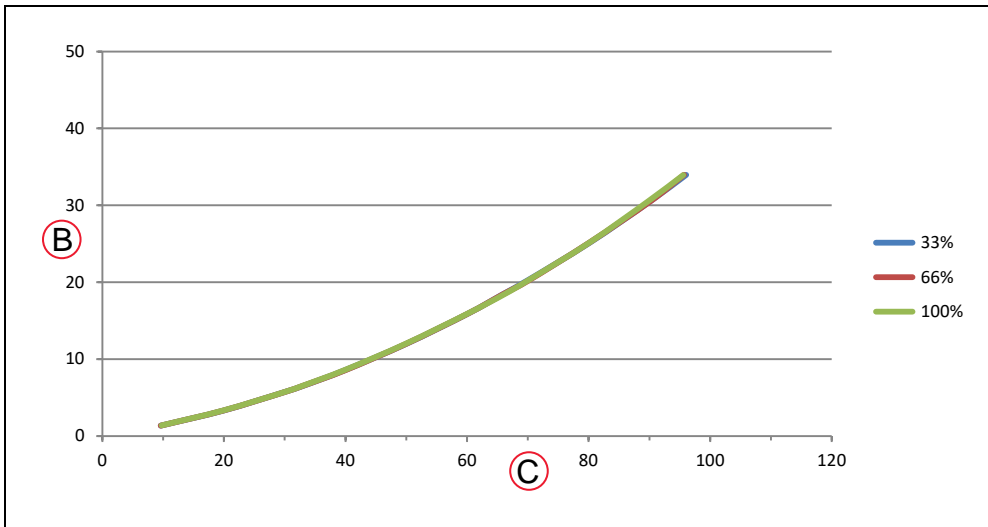

Figure 8-12. Joint 1 Stopping Distance for Viper 850, in Degrees

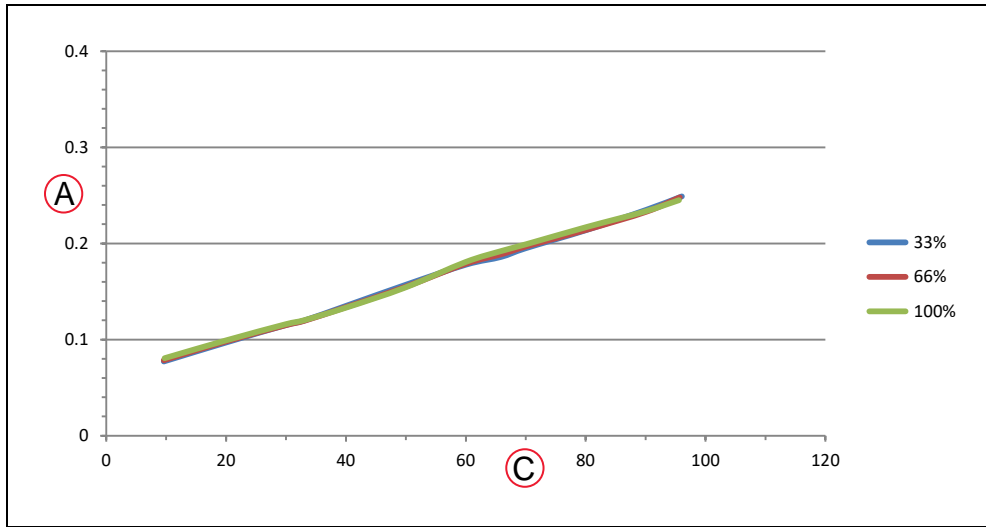

Figure 8-13. Joint 1 Stopping Time for Viper 850, in Seconds

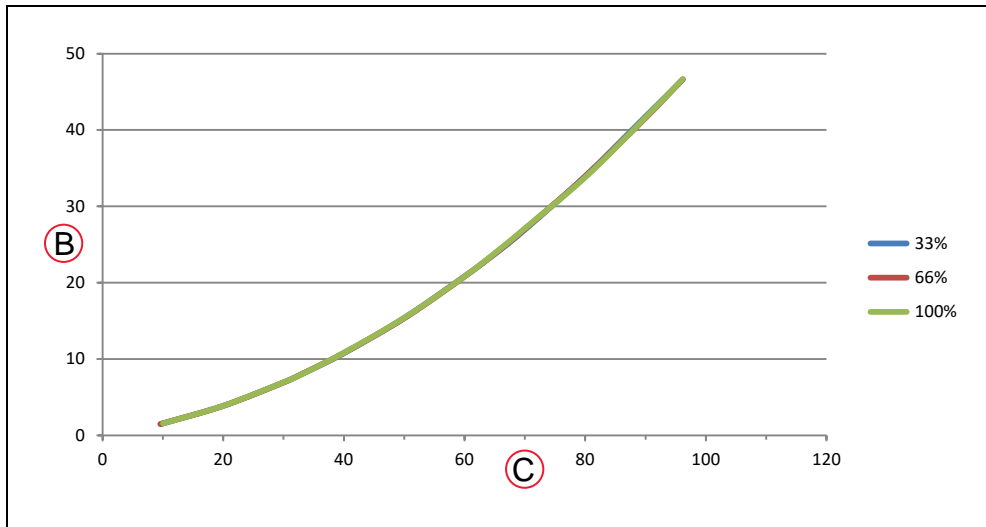

Figure 8-14. Joint 2 Stopping Distance for Viper 850, in Degrees

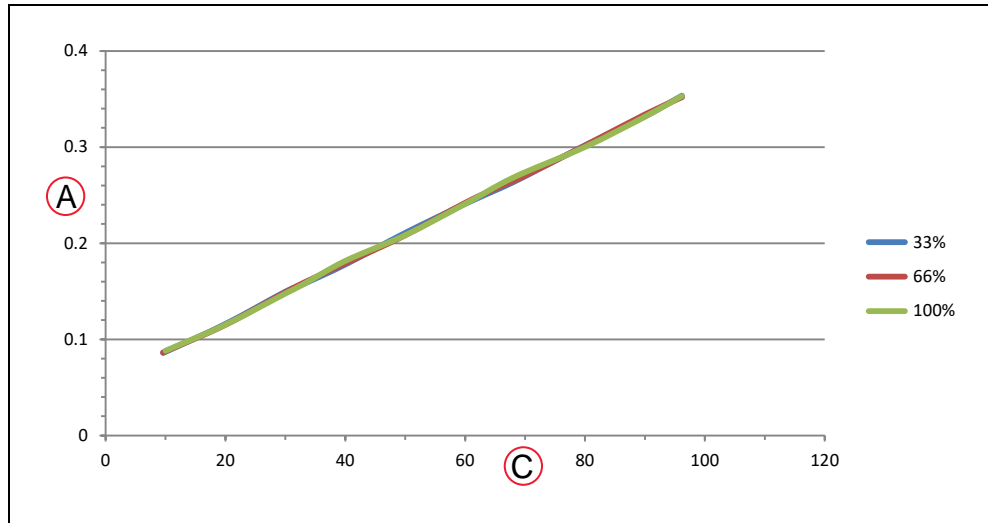

Figure 8-15. Joint 2 Stopping Time for Viper 850, in Seconds

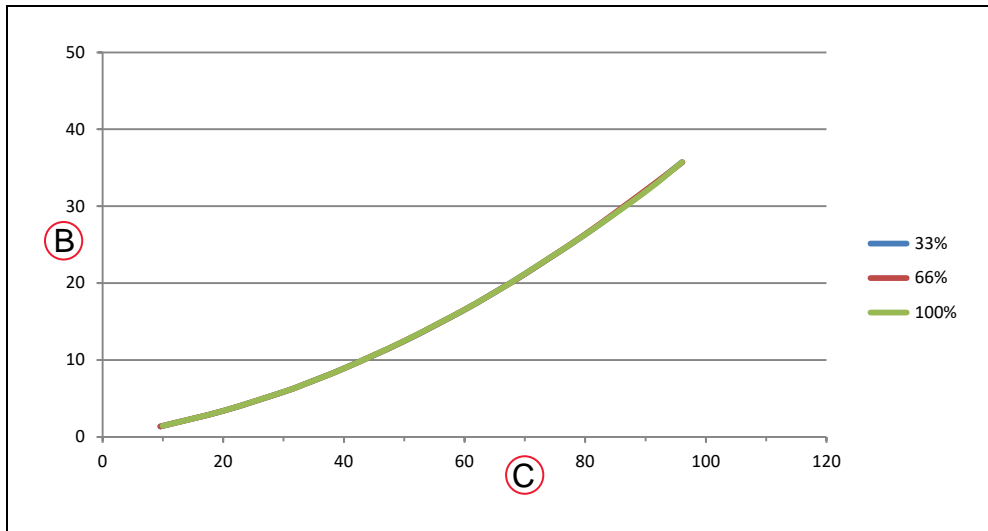

Figure 8-16. Joint 3 Stopping Distance for Viper 850, in Degrees

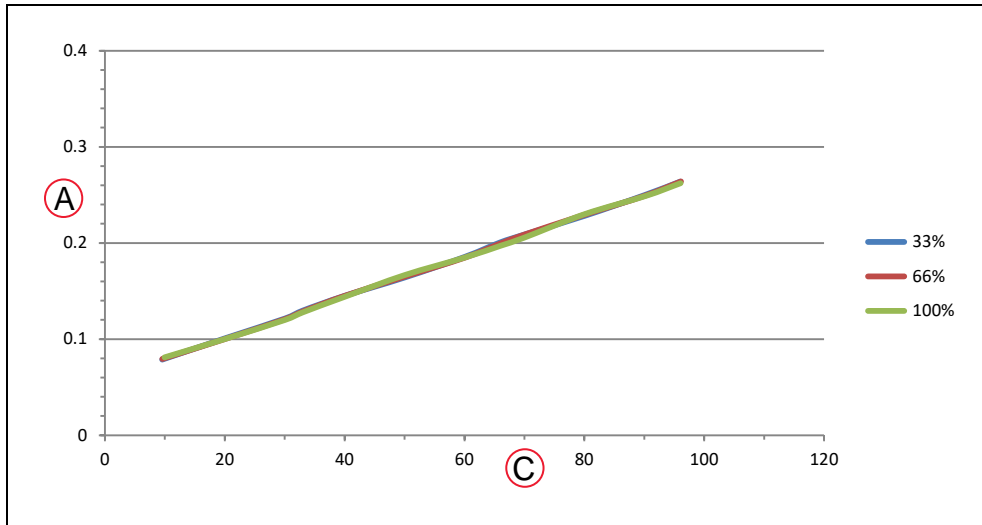

Figure 8-17. Joint 3 Stopping Time for Viper 850, in Seconds

Aging and normal use will not degrade stopping distances and times. Stopping distances will vary only if there is an actuating mechanism failure, which could require replacing the failed component.

If an integrator wants to measure stopping distances and times in a real cell with a real robot and with real tools and loads, they should contact their local Omron support.

Chapter 9: IP54/65 Option

9.1 Introduction

The Viper 650 and 850 robots can be ordered with an IP54/65 option that is a dust-proof, splash-proof model. With the IP54/65 option, the main body of the robot is rated IP54, and Joints 4, 5, 6 are rated IP65. Without this option, the robots have a rating of IP40.



CAUTION: The SmartController and eMB-40/60R are not dust- or splash-proof. Therefore, when using these products in an environment exposed to dust or mist, put them in protective enclosures.



Figure 9-1. Viper 650 Robot with IP54/65 Option

9.2 Differences from the Standard Robot Model

The installation, operation, and specifications of the IP54/65 robot are the same as the standard robot, except for issues noted in this section.

Installation Environment

The IP54/65 robot should not be installed in any environment where:

- there are any flammable gases or liquids,
- there are any acidic, alkaline, or other corrosive gases,
- there are any large-sized inverters, high output/high frequency transmitters, large contactors, welders, or other sources of electrical noise,
- it may likely be submerged in fluid,
- there is sulfuric cutting or grinding oil mist.

NOTE: Any machining oil used around the robot must be compatible with NBR (nitrile) and a polyurethane resin paint.

Robot Connector Panel

For the IP54/65 robot, the robot connector panel is different than the standard robot. The panel is shown in the following figure.

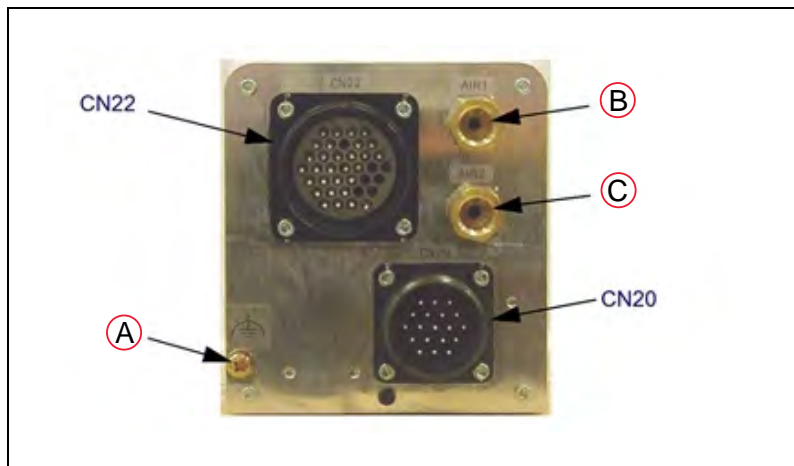

Figure 9-2. IP54/65 Robot Connector Panel

Key	Meaning	Key	Meaning
A	Ground Terminal	C	Air 2
B	Air 1		

NOTE: On the IP54/65 robot, the CN20 and CN21 connectors are IP65 rated. Also, the robot cable has a splash-proof connector on the robot end.

NOTE: The mating connector sets for CN20 and CN21 are different for IP54/65 and Cleanroom robots. See Cleanroom Option on page 133.

NOTE: For IP54/65 compliance, keep the factory-installed plugs over I/O connectors in place.

Cable Clearance

For the IP54/65 robot, the cable clearance dimension at the back of the robot is 222 mm. See Technical Specifications on page 115 for dimension drawings.

Replacing Encoder Backup Battery

For the IP54/65 robot, the procedure to replace the encoder battery is the same as the standard robot, except the cover uses hex socket-head bolts instead of screws. Removing Cover to Replace Encoder Batteries on page 103. Tightening torque: Hex socket bolt: 2.0 N·m (1.5 ft-lbf).

Chapter 10: Cleanroom Option

10.1 Introduction

The Viper 650 and 850 robots are available in Class 10 Cleanroom models.



Figure 10-1. Viper 850 Robot - Cleanroom Model

10.2 Differences from Standard Robot Model

The installation, operation, and specifications of the Cleanroom robot are the same as the standard robot, except for issues noted in this section.

Cleanroom Technical Specifications

Table 10-1. Cleanroom Robot Specifications

Viper 650/850	
Clean Class for Cleanroom Robot	Class 10
Recommended vacuum flow rate	130 liters/minute (4.6 SCFM)
User air lines	6 systems (Ø4x6), 3 solenoid valves (2-position, double solenoid) contained.

Robot Connector Panel

For the Cleanroom robot, the robot connector panel is different than the standard robot.

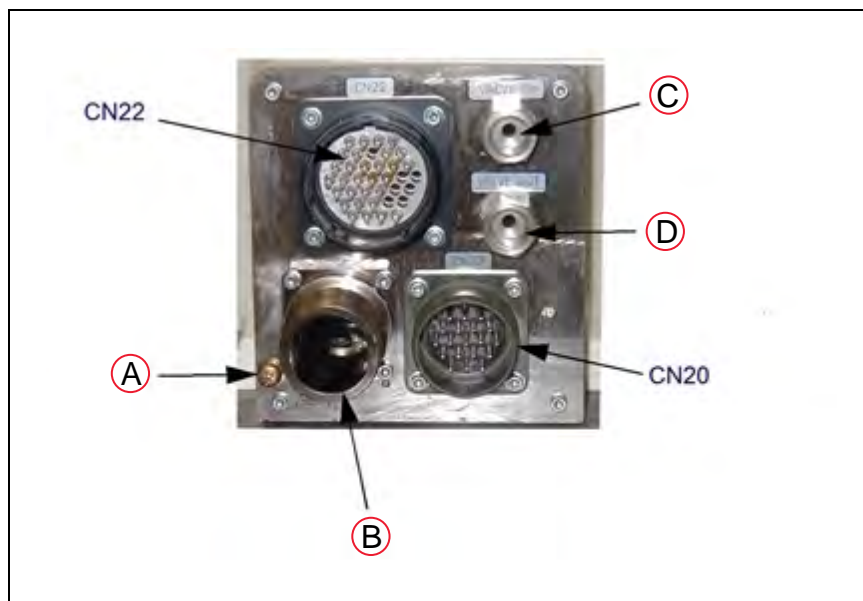

Figure 10-2. Cleanroom Robot Connector Panel

Key	Meaning	Key	Meaning
A	Ground Terminal	C	Valve In Air Intake for Solenoids (¼ inch BSPT)
B	Vacuum Connection, OD Ø 32, ID Ø 25	D	Valve Out Exhaust from Solenoids (¼ inch BSPT)

For the end of the cable, line up the slot in the cable end with the matching key in the connector, apply firm pressure straight in, and thread the lock ring fully onto the connector. There should be no visible threads when connected.

For the robot end of the cable, line up the keys (1 large, 4 small) on the cable end with the grooves in the connector, apply firm pressure straight in, and twist the locking ring a quarter turn. You should hear and feel a click as it latches into place.

See Cleanroom Technical Specifications on page 134 for the recommended vacuum flow rate.

10.3 Air Lines and Signal Wiring

The Cleanroom robot is equipped with six air lines. The six lines, from Valve In input, are controlled by the three internal solenoid valves. There are ten user electric lines. The air lines and signal wiring are shown in the following figures and tables.

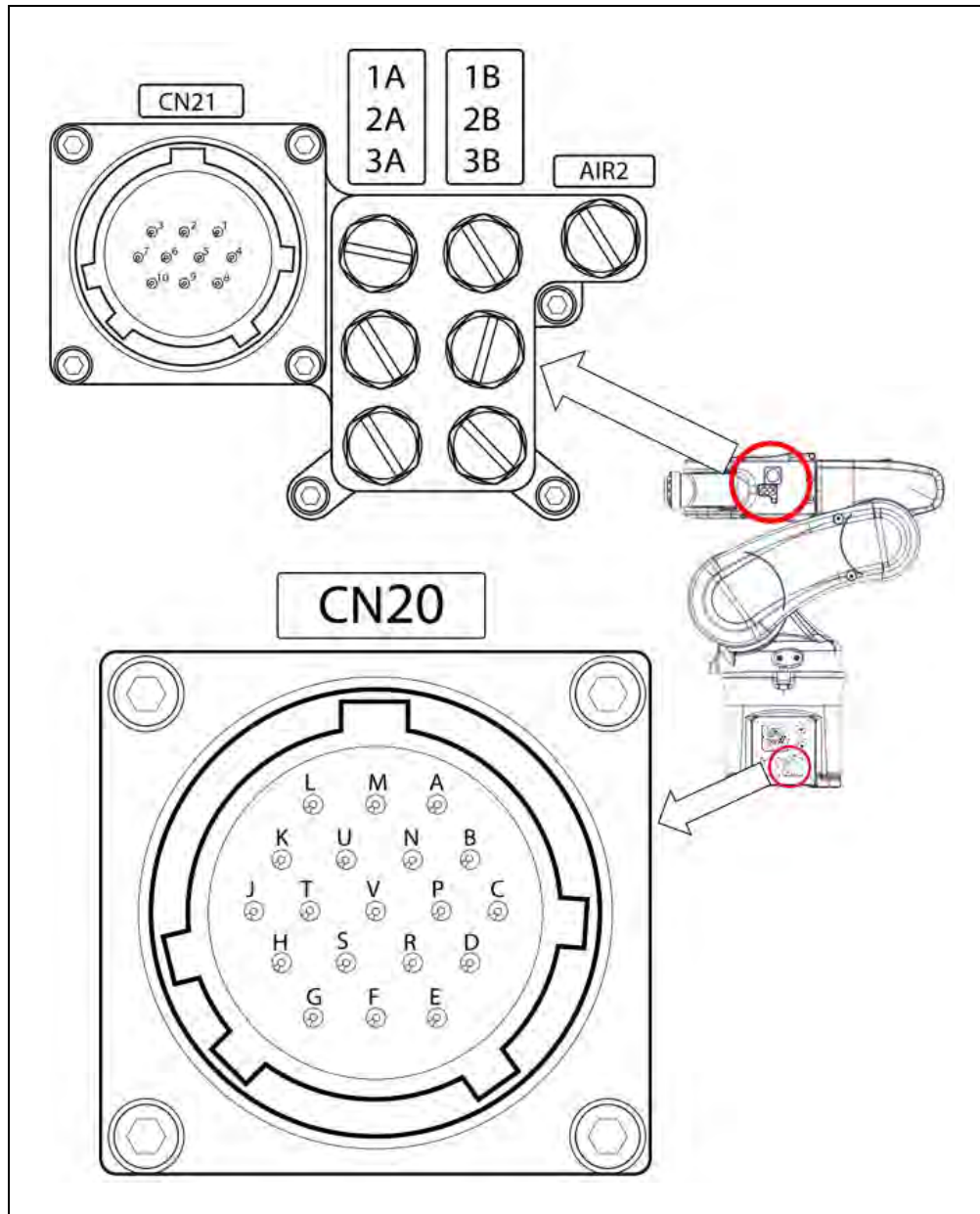

Figure 10-3. Air Intake/Exhaust Connections and Signals

Table 10-2. Air Intake/Exhaust States

Air Connections		Valve Signal		
Intake (Valve in)	Exhaust (Valve out)	Solenoid Valve	Solenoid	
			A	B
1A	1B	1	ON	OFF
1B	1A	1	OFF	ON
2A	2B	2	ON	OFF
2B	2A	2	OFF	ON
3A	3B	3	ON	OFF
3B	3A	3	OFF	ON
AIR 2 - Not used on Cleanroom robot				

Table 10-3. CN20 Pin Assignments, M to U

NPN type (source IN, sink OUT)		PNP type (sink IN, source OUT)	
CN20 pin	Used for:	CN20 pin	Used for:
M	+24 V	M	0 V
N	Solenoid 1A (solenoid valve 1)	N	Solenoid 1A (solenoid valve 1)
P	Solenoid 1B (solenoid valve 1)	P	Solenoid 1B (solenoid valve 1)
R	Solenoid 2A (solenoid valve 2)	R	Solenoid 2A (solenoid valve 2)
S	Solenoid 2B (solenoid valve 2)	S	Solenoid 2B (solenoid valve 2)
T	Solenoid 3A (solenoid valve 3)	T	Solenoid 3A (solenoid valve 3)
U	Solenoid 3B (solenoid valve 3)	U	Solenoid 3B (solenoid valve 3)



Pins A to K on CN20 and #1 to #10 on CN21 are connected with each other as shown below. The allowable current per line is 1 A.

CN20	A	B	C	D	E	F	G	H	J	K
CN21	1	2	3	4	5	6	7	8	9	10

Use the supplied mating connector sets shown in the table below for CN20 and CN21.

CN20 and CN21 Mating Connectors

Table 10-4. CN20 and CN21 Mating Connectors

Connector Set Part No.	Connector No.	Model and Part Name	Appearance	Connector Set Part No.
05584-000	for CN20	H/M3106A22-14S (straight plug) (HIROSE ELECTRIC CO., LTD.)		
	for CN20	H/MS3057-12A (cord clamp) (HIROSE ELECTRIC CO., LTD.)	Applicable wire diameter 11.4 to 15.9	
	for CN20	H/MS3057-12A1 (cord clamp) (HIROSE ELECTRIC CO., LTD.)	Applicable wire diameter 8 to 11.6	
	for CN21	EBLP1610M (L type plug connector) (Dai-ichi Electronic Industry)		

NOTE: The mating connectors are the same for Cleanroom and IP54/65 robots.

10.4 Cleanroom Cover at J6 Flange

The Cleanroom robot has a J6 Cleanroom Cover that is not present on the standard robot. See the following figure.

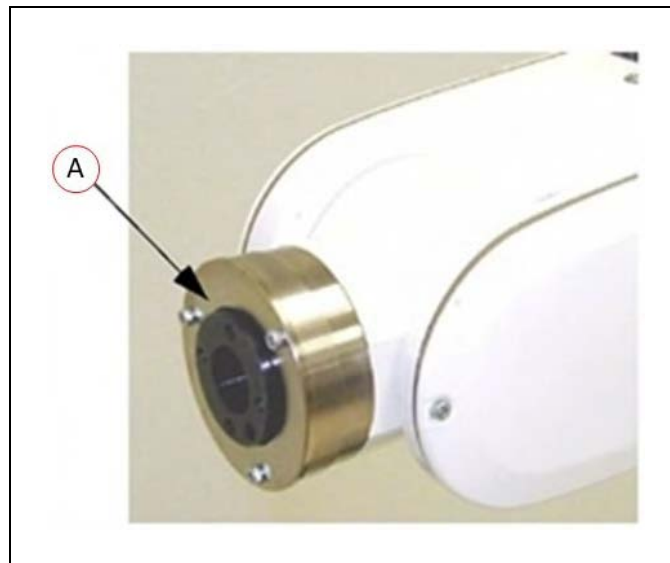

Figure 10-4. (A) Viper 850 J6 Cleanroom Cover

Any user tooling at the flange must allow for clearance. See the following figure.

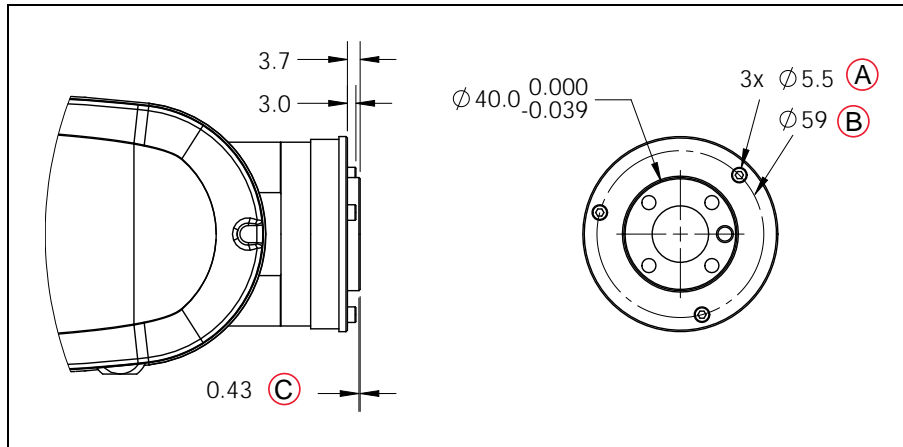

Figure 10-5. J6 Cleanroom Cover Dimensions

Key	Meaning	Key	Meaning
A	M3 Bolt Head	C	Chamfer
B	Bolt Circle (BC)		

NOTE: Clearance must be made between the J6 Cleanroom Cover and user tooling.

10.5 Cable Clearance

For the Cleanroom robot, the cable clearance dimension at the back of the robot is 222 mm. Technical Specifications on page 115 for dimension drawings.

10.6 Replacing Encoder Backup Battery

For the Cleanroom robot, the procedure to replace the encoder battery is the same as the standard robot, except the cover uses hex socket-head bolts instead of screws. See Battery Replacement Procedure on page 102. Tightening torque: Hex socket bolt: 2.0 N·m (1.5 ft-lbf).

Chapter 11: Status Codes

11.1 Introduction

Status Panel Display

The Status Panel Display is located near the top of the eMB-40/60R and typically on the robot itself for eAIB robots. See the following figure.

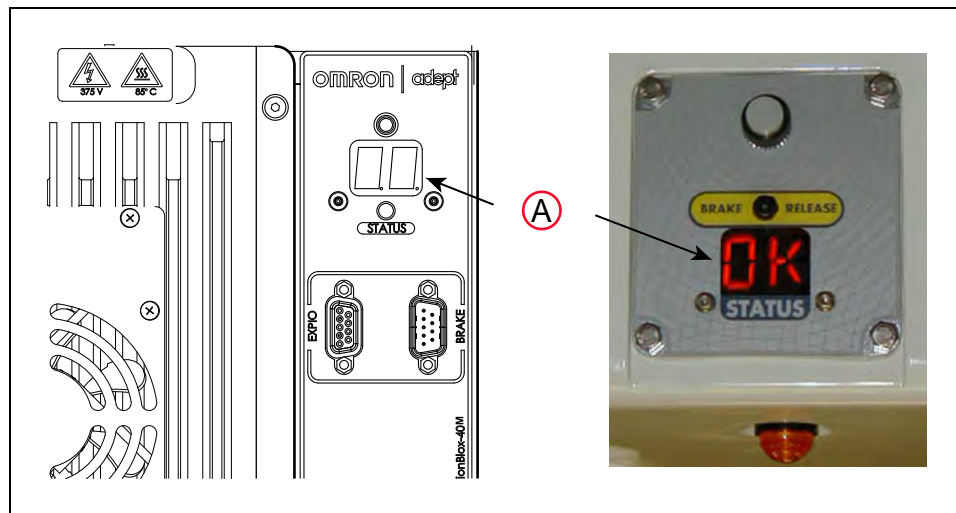

Figure 11-1. (A) Status Panel Displays on eMB-40/60R and Viper

Status Panel

The status panel, shown in the preceding figure, displays alpha-numeric codes that indicate the operating status of the eMB-40/60R. These codes provide details for quickly isolating problems during troubleshooting.

In the Status Panel Codes table, the '#' in the LED column represents a single digit. The digits will be displayed as one of the following:

0	1	2	3	4	5	6	7	8	9
0	1	2	3	4	5	6	7	8	9

Table 11-1. Status Panel Codes

LED	Text	Status Code	LED	Text	Status Code
OK	OK	No Fault	h#	h#	High Temp Amp (Joint #)
ON	ON	High Power ON Status	H#	H#	High Temp Encoder (Joint #)
MA	MA	Manual Mode	HV	HV	High Voltage Bus Fault
24	24	24 V Supply Fault	I#	I#	Initialization Stage (Step #)
A#	A#	Amp Fault (Joint #)	M#	M#	Motor Stalled (Joint #)
AC	AC	AC Power Fault	P#	P#	Power System Fault (Code #)
BA	BA	Backup Battery Low Voltage	PR	PR	Processor Overloaded
B#	B#	IO Blox Fault (Address #)	RC	RC	RSC Fault
D#	D#	Duty Cycle Exceeded (Joint #)	S#	S#	Safety System Fault (Code #)
E#	E#	Encoder Fault (Joint #)	SE	SE	E-Stop Delay Fault
ES	ES	E-Stop	SW	SW	Watchdog Timeout
F#	F#	External Sensor Stop	T#	T#	Safety System Fault (Code 10 + #)
FM	FM	Firmware Mismatch	TR	TR	Teach Restrict Fault
FW	FW	1394 Fault	V#	V#	Hard Envelope Error (Joint #)

NOTE: Due to the nature of the Viper 650/850 bus line encoder wiring, a single encoder wiring error may result in multiple channels of displayed encoder errors. Reference the lowest encoder number displayed.

LED	Status Code	V+ Error Message	V+ Error Code	Explanation	User Action
OK	OK	None	N/A	STATUS message-High Power OFF.	None
ON	ON	None	N/A	STATUS message-High Power ON.	None
MA	MA	None	N/A	STATUS message-Robot is in Manual Mode.	None
24	24	*RSC power failure*	-670	The 24 VDC input voltage is out of bounds (too high or low).	Check connections and voltage level from the user-supplied 24 VDC power supply.
A#	A#	*Motor Amplifier Fault*	-1018	A power amplifier fault is indicated on axis #.	Check user motor power connections for shorts or opens. Turn high power back on and restart the program. If the error persists, contact your local Omron support.
AC	AC	*RSC Power Failure*	-670	A loss of AC power was detected	Check user AC power connections for shorts or opens. Turn high power back on and restart the program. If the error persists, contact your local Omron support.
B#	B#	None	N/A	IO-Blox communications error with IO-Blox (#).	Check user IOBlox connections for shorts or opens. Check IOBlox address switches for proper configuration. Cycle power to the control system. If the error persists, contact your local Omron support.
BA	BA	None	N/A	The encoder backup battery is low.	Replace the encoder backup battery.
D#	D#	*Duty-cycle exceeded*	-1021	The indicated motor (#) has been driven hard for	Turn high power back on; reduce the

LED	Status Code	V+ Error Message	V+ Error Code	Explanation	User Action
		Mtr #		too long a period of time. The servo system has disabled power to protect the robot hardware.	speed and/or acceleration for the motion that was in progress or for motions that preceded that motion. Repeat the motion that failed.
E#	E#	*Encoder Fault*	-1025	The servo system has detected an encoder fault.	User actions vary by product. Please reference individual robot manuals for appropriate actions.
ES	ES	*E-STOP detected by robot*	-643	An E-STOP condition has been detected by the robot.	This is a normal response to many E-STOP conditions. Remove the source of the ESTOP and re-enable high power.
F1	F1	*E-STOP detected by robot*	-643	The End-Of-Arm Break-away Sensor has tripped (open circuit). Reporting of this error can be enabled / disabled via ACE.	Re-close the break-away circuit and re-enable high power.
F2	F2	*E-STOP detected by robot*	-643	The End-Of-Arm "SHOCK" Sensor has tripped (open circuit). Reporting of this error can be enabled / disabled via ACE. The shock sensor is an option on the AdeptSix robot line.	This is an expected response to impact with an obstacle on robots with the shock sensor option installed. Move the robot away from the obstacle and re-enable high power.
F3	F3	*E-STOP detected by robot*	-643	The "LIMIT" Sensor has tripped. Reporting of this error can be enabled / disabled via a SPEC option. A single common sensor is used to report a limit condition on J1 and J2/J3 if the option is installed.	This is an expected response when the joint limit switch has been activated. Move the robot away from the limit position and re-enable high power.
FM	FM	None	N/A	Firmware version mismatch.	Contact your local Omron support.

LED	Status Code	V+ Error Message	V+ Error Code	Explanation	User Action
FW	FW	*1394 communications timeout*	-927	The IEEE 1394 communications system has failed to initialize or has lost communications with the SmartController.	This will occur normally if the SmartController is powered down separately from the robot systems. If it occurs unexpectedly, check the connections and integrity of the 1394 cabling.
h#	h#	*Robot overheated*	-606	The temperature sensor on the embedded processor board has reached its temperature limit. It may be necessary to slow the motion or insert pauses to reduce overall heating.	Check for excessive ambient temperature, inadequate ventilation, and proper function of any cooling fans.
H#	H#	*Motor overheating* Mtr #	-1016	The motor encoder temperature sensor indicates an overtemperature.	Reduce the speed, acceleration and/or deceleration of the robot motions, or introduce delays in the application cycle to give the motor an opportunity to cool.
hV	hV	*RSC power failure*	-670	The high-voltage DC bus for the amplifiers is out of bounds (too high or low).	This may occur when AC power is unexpectedly removed. Check AC connections and re-enable high power. If the error persists, contact your local Omron support.
I#	I#	None	N/A	Servo initialization stages. These steps normally sequence (I0, I1, ...) on the display during normal system boot.	None, unless an initialization code persists longer than 30 seconds. This may indicate servo initialization has failed. Contact your local Omron support.
M#	M#	*Motor stalled* Mtr #	-1007	A motor stall occurs when the maximum	Check for obstacles and free movement

LED	Status Code	V+ Error Message	V+ Error Code	Explanation	User Action
				allowed torque for a given motor was applied for longer than the defined timeout period. This typically occurs when an obstacle is encountered.	of all joints. Turn high power back on and repeat the motion that failed.
<i>NV</i>	NV	None	N/A	Communication to a Non-Volatile memory device failed.	On MB-10 units, clean the contacts to the signature card mounted on the T-bracket and check for proper mounting of the MB-10. If the error persists, contact your local Omron support.
<i>P0</i>	P0	*Power system failure* Code 0	-1115	The dual-channel brake circuit has reported a cyclic check error.	Contact your local Omron support.
<i>P1</i>	P1	*Power system failure* Code 1	-1115	The power system has unexpectedly turned off power.	On PA-4 chassis, further information may be indicated on the PA-4 status lights. Refer to Adept PA-4 Power Chassis User's Guide for details. Contact your local Omron support if the error persists.
<i>P2</i>	P2	*Power system failure* Code 2	-1115	The high-voltage DC bus to the regenerative energy dump circuit has experienced an over-voltage.	Contact your local Omron support.
<i>P3</i>	P3	*Power system failure* Code 3	-1115	The regenerative energy dump circuit has exceeded its max short-term dump rating.	Contact your local Omron support.
<i>P4</i>	P4	*Power system failure* Code 4	-1115	The high-voltage DC bus did not discharge its voltage when expected. (Note: This error is only relevant to legacy Cobra AIB systems.)	Contact your local Omron support.

LED	Status Code	V+ Error Message	V+ Error Code	Explanation	User Action
PS	P5	*Power system failure* Code 5	-1115	An inrush error was detected by the power sequencer. This means the high-voltage DC bus failed to rise at the expected rate when power was enabled.	This can occur if AC power is abruptly removed during the high-power enable sequence. If it occurs unexpectedly, contact your local Omron support.
	P6	*Power system failure* Code 6	-1115	The MAI-2 / sMAI / sDAI regenerative energy circuit temperature sensor indicates an overtemp condition.	Contact your local Omron support.
PR	PR	None	N/A	A servo task has overrun its allotted execution window.	If the problem persists, contact your local Omron support.
RC	RC	*RSC communications failure*	-651	There is a failure to communicate with the Robot Signature Card.	Contact your local Omron support.
S0	S0	*Safety System Fault* Code 0	-1109*	The robot hardware did not detect that the front-panel high-power button was pressed prior to the servo system attempting to enable power.	Contact your local Omron support.
S1	S1	*Safety System Fault* Code 1	-1109*	The SmartController has signaled a power off condition to the robot via the HIPWR_DIS line on the XSYS interface. This fault indication typically accompanies other fault conditions that cause "fatal error" on the Smart-Controller error (such as a loss in IEEE-1394 communication).	Check for other messages on the SmartController that may indicate a fatal error. If the error source can be eliminated, re-enable power.
S2	S2	*Safety System Fault* Code 2	-1109*	The safety system experienced a failure on channel 1 during the cyclic check of dual-channel power system. This may indicate a welded relay	If the problem persists, contact your local Omron support.

LED	Status Code	V+ Error Message	V+ Error Code	Explanation	User Action
				contact or other hardware failure.	
S3	S3	*Safety System Fault* Code 3	-1109*	The safety system experienced a failure on channel 2 during the cyclic check of dual-channel power system. This may indicate a welded relay contact or other hardware failure.	If the problem persists, contact your local Omron support.
S4	S4	*Safety System Fault* Code 4	-1109*	The internal E-STOP delay timer timed out and power has been turned off. Under normal circumstances, software sequences the shutdown prior to the timeout, averting this message.	If the problem persists, contact your local Omron support.
S5	S5	*Safety System Fault* Code 5	-1109*	The power system was not properly unlocked by software during a power sequence while in manual mode.	Contact your local Omron support.
S6	S6	*Safety System Fault* Code 6	-1109*	The CAT-3 hardware safety system detected an encoder OVERSPEED and power has been turned off. This circuitry is active in manual mode only, on select robots which have the CAT-3 teach mode option installed.	This fault is triggered on purpose during specific commissioning tests for the CAT-3 system. If the fault occurs during normal operation, contact your local Omron support.
S9	S9	*Safety System Fault* Code 9	-1109*	A watchdog circuit that cross-checks the clocks for the dual-channel safety system is reporting an error.	Contact your local Omron support.
SE	SE	*Safety System Not Commissioned*	-648	The E-Stop Delay has not been commissioned and verified.	Commission and verify the E-Stop Delay.
SW	SW	None	N/A	Software watchdog timer timeout. On some products it is normal for	If the problem persists, contact your local Omron support.

LED	Status Code	V+ Error Message	V+ Error Code	Explanation	User Action
				this to occur momentarily during a servo reset.	
T0	T0	*Safety System Fault* Code 10	-1109	An error was detected during a software self test of a secondary safety and monitoring circuit (SRV_DIRECT / SRV_STAT).	Contact your local Omron support.
T1	T1	*Safety System Fault* Code 11	-1109	A failure (open circuit) of the arm-mounted high power lamp has been detected. The lamp is probably burned out. This is considered a safety hazard and high power cannot be enabled until the lamp is replaced. The arm-mounted high power lamp is currently only an option on the Adept-Six 600 robot.	Replace the bulb in the arm-mounted high power lamp.
TR	TR	*Safety System Not Commissioned*	-648	The Teach Restrict feature has not been commissioned and verified.	Commission and verify the Teach Restrict feature.
V#	V#	*Hard envelope error* Mtr #	-1027	The indicated motor was not tracking the commanded position with sufficient accuracy as set by ACE.	Turn on high power and try to perform the motion at a slower speed. Make sure that nothing is obstructing the robot's motion. If the error recurs, contact your local Omron support.

OMRON Corporation Industrial Automation Company

Kyoto, JAPAN

Contact: www.ia.omron.com

Regional Headquarters

OMRON EUROPE B.V.

Wegalaan 67-69, 2132 JD Hoofddorp
The Netherlands
Tel: (31)2356-81-300/Fax: (31)2356-81-388

OMRON ASIA PACIFIC PTE. LTD.

No. 438A Alexandra Road # 05-05/08 (Lobby 2),
Alexandra Technopark,
Singapore 119967
Tel: (65) 6835-3011/Fax: (65) 6835-2711

OMRON ELECTRONICS LLC

2895 Greenspoint Parkway, Suite 200 Hoffman Estates,
IL 60169 U.S.A.
Tel: (1) 847-843-7900/Fax: (1) 847-843-7787

OMRON ADEPT TECHNOLOGIES, INC.

4550 Norris Canyon Road, Suite 150, San Ramon, CA 94583 U.S.A.
Tel: (1) 925-245-3400/Fax: (1) 925-960-0590

OMRON (CHINA) CO., LTD.

Room 2211, Bank of China Tower, 200 Yin Cheng Zhong Road,
PuDong New Area, Shanghai, 200120, China
Tel: (86) 21-5037-2222/Fax: (86) 21-5037-2200

Authorized Distributor:

© OMRON Corporation 2016-2019 All Rights Reserved.
In the interest of product improvement,
specifications are subject to change without notice.

Cat. No. I599-E-05

Printed in USA
0319 (0416)

05173-060M