

SIEMENS



Motion Control Drives

SINAMICS Converters for Single-Axis Drives



SINAMICS G120XA infrastructure converters
for standard pumps/fans

Catalog
D 31.6

Edition
January
2019

siemens.com.cn/sinamics-g120xa

Related catalogs

<p>Motion Control Drives D 31.1 SINAMICS Inverters for Single-Axis Drives Built-In Units</p> <p>E86060-K5531-A111-A1-7600</p>		<p>Industrial Controls IC 10 SIRIUS</p> <p>PDF (E86060-K1010-A101-A9-7600)</p>	
<p>Motion Control Drives D 31.2 SINAMICS Inverters for Single-Axis Drives Distributed Inverters</p> <p>E86060-K5531-A121-A1-7600</p>		<p>Industrial Controls IC 10 AO SIRIUS Classic</p> <p>PDF (E86060-K1010-A191-A5-7600)</p>	
<p>SINAMICS S120 D 21.3 Chassis Format Converter Units Cabinet Modules</p> <p>SINAMICS S150 Converter Cabinet Units E86060-K5521-A131-A6-7600</p>		<p>Low-Voltage Power Distribution and Electrical Installation Technology LV 10 SENTRON • SIVACON • ALPHA Protection, Switching, Measuring and Monitoring Devices, Switchboards and Distribution Systems PDF (E86060-K8280-A101-A7-7600) Print (E86060-K8280-A101-A6-7600)</p>	
<p>Motion Control Drives D 21.4 SINAMICS S120 and SIMOTICS</p> <p>E86060-K5521-A141-A1-7600</p>		<p>SIMATIC ST 70 Products for Totally Integrated Automation</p> <p>E86060-K4670-A101-B6-7600</p>	
<p>SIMOTICS S-1FG1 D 41 Servo geared motors Helical, Parallel shaft, Bevel and Helical worm geared motors</p> <p>E86060-K5541-A101-A3-7600</p>		<p>SIMATIC ST 70 N Products for Totally Integrated Automation</p> <p>E86060-K4670-A151-A9-7600</p>	
<p>SIMOTICS GP, SD, XP, DP D 81.1 Low-Voltage Motors Type series 1FP1, 1LE1, 1LE5, 1MB1 and 1PC1 Frame sizes 63 to 355 Power range 0.09 to 500 kW E86060-K5581-A111-B2-7600</p>		<p>SIMATIC HMI / PC-based Automation ST 80/ST PC Human Machine Interface Systems PC-based Automation</p> <p>E86060-K4680-A101-C6-7600</p>	
<p>FLENDER Couplings MD 10.1 Standard Couplings</p> <p>E86060-K5710-A111-A5-7600</p>		<p>Industrial Communication IK PI SIMATIC NET</p> <p>E86060-K6710-A101-B8-7600</p>	
<p>SIMOGEAR MD 50.1 Geared Motors Helical, parallel shaft, bevel, helical worm and worm geared motors</p> <p>E86060-K5250-A111-A5-7600</p>		<p>Products for Automation and Drives CA 01 Interactive Catalog Download</p> <p>www.siemens.com/ca01download</p>	
<p>Motion Control System PM 21 SIMOTION Equipment for Production Machines</p> <p>E86060-K4921-A101-A4-7600</p>		<p>Industry Mall Information and Ordering Platform on the Internet:</p> <p>www.siemens.com/industrymall</p>	

The Siemens logo is displayed in a white rectangular box. The logo itself is the word "SIEMENS" in a bold, teal, sans-serif font.

SINAMICS Converters for Single-Axis Drives

SINAMICS G120XA infrastructure converters
for standard pumps/fans
Catalog D 31.6 · January 2019

Dear Customer,

We are happy to present you with the PDF version of the new Catalog D 31.6 · January 2019.

The catalog provides a comprehensive overview of the new SINAMICS G120XA infrastructure converter system for standard pump and fan applications. With an available power range from 0.75 kW to 560 kW, the new series masters every challenge here.

The products listed in this Catalog are also included in the Industry Mall.
Please contact your local Siemens office for additional information.

Up-to-date information about SINAMICS G120XA is available online at
www.siemens.com.cn/sinamics-g120xa

You can access our Interactive Catalog and our Industry Mall on the Internet at:
www.siemens.com/industrymall

Your personal contact will be glad to receive your suggestions and recommendations for improvement. You can find your representative in our personal contacts database at
www.siemens.com/automation-contact

We hope that you will often enjoy using Catalog D 31.6 as a selection and ordering reference document and wish you every success with our products and solutions.

With kind regards,

A handwritten signature in blue ink, appearing to read "Achim Peltz".

Achim Peltz
Vice President
General Motion Control
Siemens AG, Digital Factory, Motion Control

SINAMICS Converters for Single-Axis Drives

SINAMICS G120XA infrastructure converters for standard pumps/fans

Motion Control Drives



Catalog D 31.6 · January 2019

Refer to the Industry Mall for current updates of this catalog:

www.siemens.com/industrymall

Please contact your local Siemens branch.

© Siemens AG 2019

System overview

1

SINAMICS G120XA infrastructure converters for standard pumps/fans

2

Engineering tools

3

Services and documentation

4

Appendix

5



The products and systems described in this catalog are manufactured/distributed under application of a certified quality management system in accordance with EN ISO 9001. The certificate is recognized by all IQNet countries.

Digital Enterprise

The building blocks that ensure everything works together perfectly in the digital enterprise

Digitalization is already changing all areas of life and existing business models. It is placing greater pressure on industry while at the same time creating new business opportunities. Today, thanks to scalable solutions from Siemens, companies can already become a digital enterprise and ensure their competitiveness.



Industry faces tremendous challenges



Reduce time-to-market

Today manufacturers have to bring products to market at an ever-increasing pace despite the growing complexity of these products. In the past, a major manufacturer would push aside a small one, but now it is a fast manufacturer that overtakes a slow one.



Boost flexibility

Consumers want customized products, but at a price they would pay for a mass-produced item. That only works if production is more flexible than ever before.



Improve quality

To ensure a high level of quality while meeting legal requirements, companies have to establish closed quality loops and enable the traceability of products.



Boost efficiency

Today the product itself needs to be sustainable and environmentally friendly, while energy efficiency in production has become a competitive advantage.



Increase security

Increasing networking escalates the threat to production facilities of cyberattacks. Today more than ever, companies need suitable security measures.



The digital enterprise has already become a reality

To fully benefit from all the advantages of digitalization, companies first have to achieve complete consistency of their data. Fully digitally integrated business processes, including those of suppliers, can help to create a digital representation of the entire value chain. This requires

- the integration of industrial software and automation,
- expansion of the communication networks,
- security in automation,
- and the use of business-specific industrial services.

MindSphere

The cloud-based open IoT operating system from Siemens

With MindSphere, Siemens offers a cost-effective and scalable cloud platform as a service (PaaS) for the development of applications. The platform, designed as an open operating system for the Internet of Things, makes it possible to improve the efficiency of plants by collecting and analyzing large volumes of production data.

Totally Integrated Automation (TIA)

Where digitalization becomes reality

Totally Integrated Automation (TIA) ensures the seamless transition from the virtual to the real world. It already encompasses all the necessary conditions for transforming the benefits of digitalization into true added value. The data that will form the digital twin for actual production is generated from a common base.

Digital Plant

Learn more about the digital enterprise for the process industry
www.siemens.com/digitalplant

Digital Enterprise Suite

Learn more about the digital enterprise for the discrete industry
www.siemens.com/digital-enterprise-suite

Integrated Drive Systems

Faster on the market and in the black with Integrated Drive Systems

Integrated Drive Systems are Siemens' trendsetting answer to the high degree of complexity that characterizes drive and automation technology today. The world's only true one-stop solution for entire drive systems is characterized in particular by its threefold integration: Horizontal, vertical, and lifecycle integration ensure that every drive system component fits seamlessly into the whole system, into any automation environment, and even into the entire lifecycle of a plant.

The outcome is an optimal workflow – from engineering all the way to service that entails more productivity, increased efficiency, and better availability. That's how Integrated Drive Systems reduce time to market and time to profit.

Horizontal integration

Integrated drive portfolio: The core elements of a fully integrated drive portfolio are frequency converters, motors, couplings, and gear units. At Siemens, they're all available from a single source. Perfectly integrated, perfectly interacting. For all power and performance classes. As standard solutions or fully customized. No other player in the market can offer a comparable portfolio. Moreover, all Siemens drive components are perfectly matched, so they are optimally interacting.

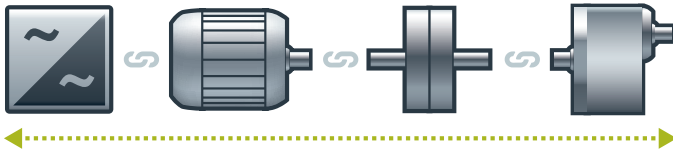

You can boost the availability of your application or plant to up to

99%*

*e.g., conveyor application

Vertical integration

Thanks to **vertical integration**, the complete drive train is seamlessly integrated in the entire automation environment – an important prerequisite for production with maximum value added. Integrated Drive Systems are part of Totally Integrated Automation (TIA), which means that they are perfectly embedded into the system architecture of the entire industrial production process. This enables optimal processes through maximum communication and control.

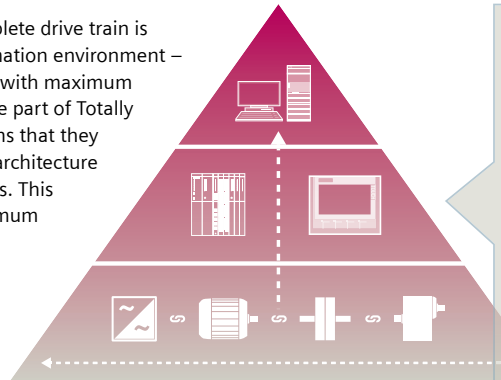

With TIA Portal you can cut your engineering time by up to

30%

Lifecycle integration

Lifecycle integration adds the factor of time: Software and service are available for the entire lifecycle of an Integrated Drive System. That way, important optimization potential for maximum productivity, increased efficiency, and highest availability can be leveraged throughout the system's lifecycle – from planning, design, and engineering to operation, maintenance, and all the way even to modernization.

With Integrated Drive Systems, assets become important success factors. They ensure shorter time to market, maximum productivity and efficiency in operation, and shorter time to profit.

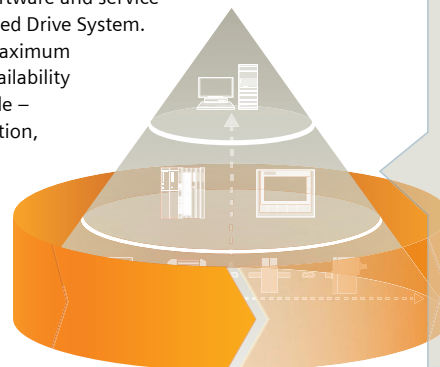

With Integrated Drive Systems you can reduce your maintenance costs by up to

15%

System overview



1/2	The SINAMICS drives family
1/6	Drive selection
1/7	SIMOTICS motors
1/8	SIMOTICS low-voltage motors for line and converter operation
1/9	Energy efficiency classes in accordance with EN 50598
1/12	SINAMICS G120XA Starter Kit

Further information about SINAMICS and SIMOTICS can be found on the Internet at
www.siemens.com/sinamics
www.siemens.com/simotics

System overview

The SINAMICS drives family

Overview

Integration in automation

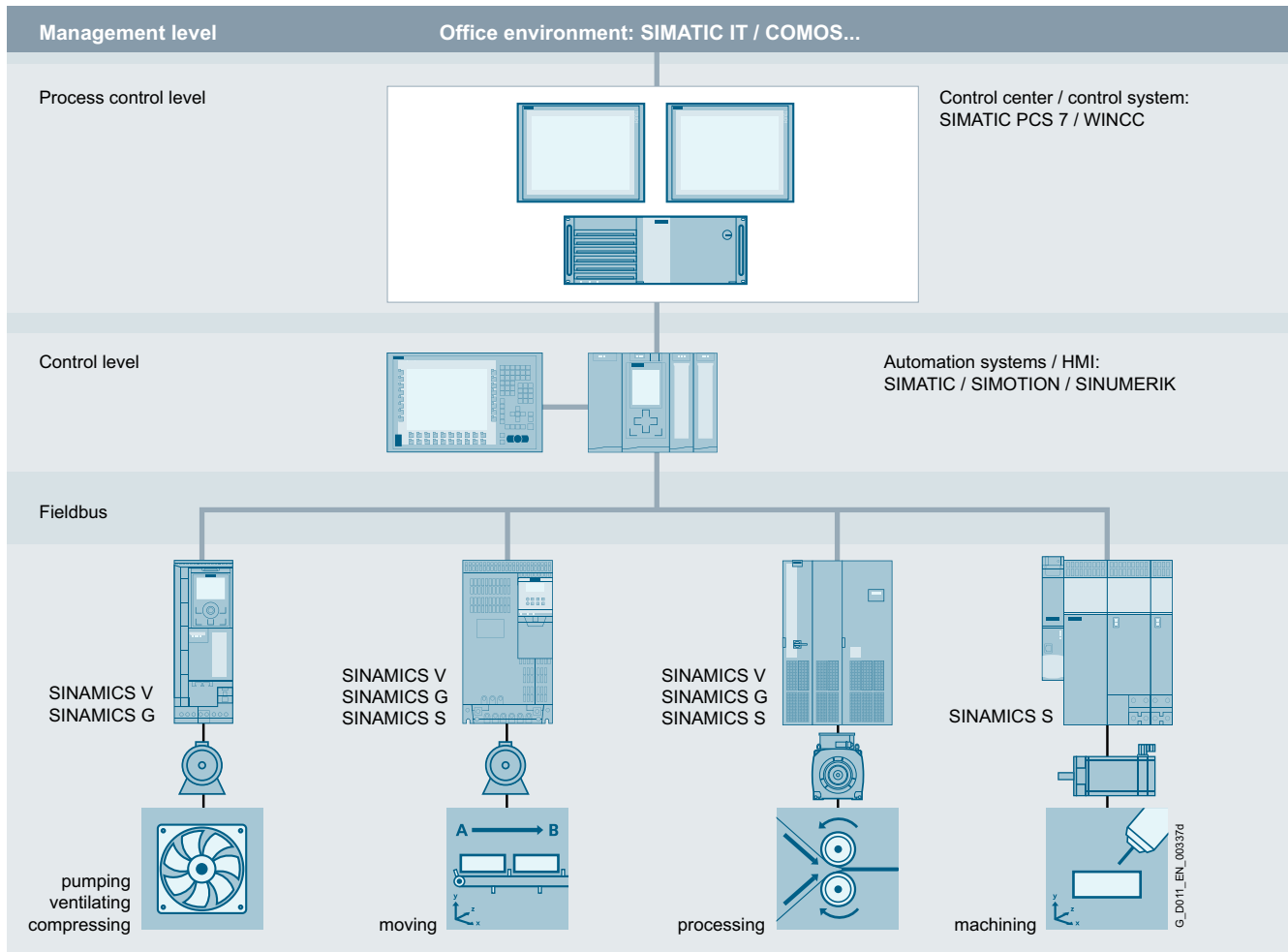

Totally Integrated Automation and communication

SINAMICS is an integral component of the Siemens "Totally Integrated Automation" concept. Integrated SINAMICS systems covering configuration, data storage, and communication at automation level ensure low-maintenance solutions with the SIMATIC, SIMOTION and SINUMERIK control systems.

Depending on the application, the appropriate variable frequency drives can be selected and incorporated in the automation concept. With this in mind, the drives are clearly subdivided into their different applications. A wide range of communication options (depending on the drive type) are available for establishing a communication link to the automation system:

- PROFINET
- PROFIBUS
- EtherNet/IP
- Modbus TCP
- Modbus RTU
- AS-Interface
- BACnet MS/TP

Applications

SINAMICS is the comprehensive family of drives from Siemens designed for machine and plant engineering applications. SINAMICS offers solutions for all drive tasks:

- Simple pump and fan applications in the process industry
- Demanding single drives in centrifuges, presses, extruders, elevators, as well as conveyor and transport systems
- Drive line-ups in textile, plastic film, and paper machines as well as in rolling mill plants
- Highly dynamic servo drives for machine tools, as well as packaging and printing machines

Overview (continued)*SINAMICS as part of the Siemens modular automation system****Innovative, energy-efficient and reliable drive systems and applications as well as services for the entire drive train***

The solutions for drive technology place great emphasis on the highest productivity, energy efficiency and reliability for all torque ranges, performance and voltage classes.

Siemens offers not only the right innovative variable frequency drive for every drive application, but also a wide range of energy-efficient low-voltage motors, geared motors, explosion-protected motors and high-voltage motors for combination with SINAMICS.

Furthermore, Siemens supports its customers with global pre-sales and after-sales services, with over 295 service points in 130 countries – and with special services e.g. application consulting or motion control solutions.

Energy efficiency***Energy management process***

Efficient energy management consultancy identifies the energy flows, determines the potential for making savings and implements them with focused activities.

Almost two thirds of the industrial power requirement is from electric motors. This makes it all the more important to use drive technology permitting energy consumption to be reduced effectively even in the configuration phase, and consequently to optimize plant availability and process stability. With SINAMICS, Siemens offers powerful energy efficient solutions which, depending on the application, enable a significant reduction in electricity costs.

System overview

The SINAMICS drives family

Overview (continued)

Up to 70 % potential for savings using variable-speed operation

SINAMICS enables great potential for savings to be realized by controlling the motor speed. In particular, huge potential savings can be recovered from pumps, fans and compressors which are operated with mechanical throttle and valves. Here, changing to variable-speed drives brings enormous economic advantages. In contrast to mechanical control systems, the power consumption at partial load operation is always immediately adjusted to the demand at that time. So energy is no longer wasted, permitting savings of up to 60 % – in exceptional cases even up to 70 %. Variable-speed drives also offer clear advantages over mechanical control systems when it comes to maintenance and repair. Current spikes when starting up the motor and strong torque surges become things of the past – and the same goes for pressure waves in pipelines, cavitation or vibrations which cause sustainable damage to the plant. Smooth starting and ramp-down relieve the load on the mechanical system, ensuring a significantly longer service life of the entire drive train.

Regenerative feedback of braking energy

In conventional drive systems, the energy produced during braking is converted to heat using braking resistors. Energy produced during braking is efficiently recovered to the supply system by versions of SINAMICS G and SINAMICS S drives with regenerative feedback capability and these devices do not therefore need a braking resistor. This permits up to 60 % of the energy requirement to be saved, e.g. in lifting applications. Energy which can be reused at other locations on a machine. Furthermore, this reduced power loss simplifies the cooling of the system, enabling a more compact design.

Energy transparency in all configuration phases

Early on, in the configuration phase, the SIZER for Siemens Drives engineering tool provides information on the specific energy requirement. The energy consumption across the entire drive train is visualized and compared with different plant concepts.

SINAMICS in combination with energy-saving motors

Engineering integration stretches beyond the SINAMICS drive family to higher-level automation systems, and to a broad spectrum of energy-efficient motors with a wide range of performance classes, which, compared to previous motors, are able to demonstrate up to 10 % greater efficiency.

Variants

Depending on the application, the SINAMICS range offers the ideal variant for any drive task.

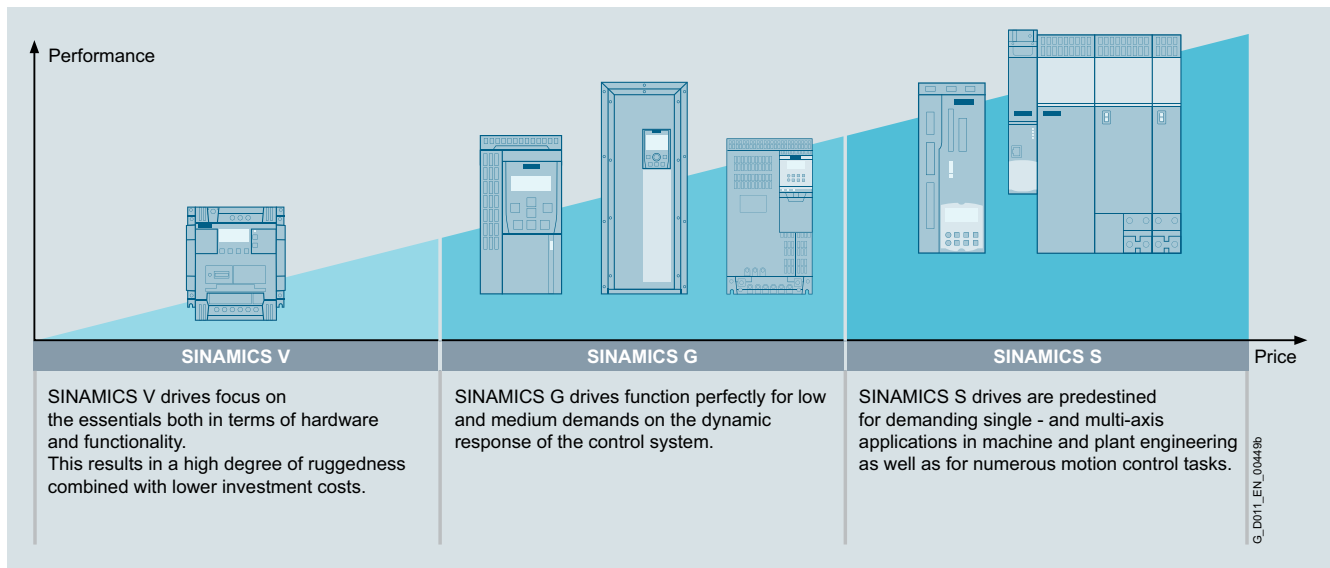

Overview (continued)**Platform concept**

All SINAMICS variants are based on a platform concept. Joint hardware and software components, as well as standardized tools for dimensioning, configuration, and commissioning tasks ensure high-level integration across all components. SINAMICS handles a wide variety of drive tasks with no system gaps. The different SINAMICS variants can be easily combined with each other.









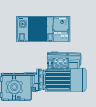

Quality management according to EN ISO 9001

SINAMICS conforms to the most exacting quality requirements. Comprehensive quality assurance measures in all development and production processes ensure a consistently high level of quality.

Of course, our quality management system is certified by an independent authority in accordance with EN ISO 9001.

IDS – Integration at its very best

The Siemens Integrated Drive Systems (IDS) solution offers perfectly matched drive components with which you can meet your requirements. The drive components reveal their true strengths as an Integrated Drive System over the full range from engineering and commissioning through to operation: Integrated system configuration is performed using the Drive Technology Configurator: Just select a motor and an converter and design them with the SIZER for Siemens Drives engineering tool. The STARTER and SINAMICS Startdrive commissioning tools integrate the motor data and at the same time simplify efficient commissioning. Integrated Drive Systems are incorporated in the TIA Portal – this simplifies engineering, commissioning and diagnostics.

Low voltage										DC voltage	Medium voltage
Basic performance		General performance					High performance			DC applications	Applications with high outputs
											
SINAMICS V20	SINAMICS V90	SINAMICS G120C G120 G120X G120XA	SINAMICS G110D G120D G120M G110M SIMATIC ET 200pro FC-2	SINAMICS G130 G150	SINAMICS G180	SINAMICS S110	SINAMICS S210	SINAMICS S120 S120M	SINAMICS S150	SINAMICS DCM	SINAMICS GH150 GH180 GM150 SM150 GL150 SL150 SM120CM
0.12 kW to 30 kW	0.05 kW to 7 kW	0.37 kW to 630 kW	0.37 kW to 7.5 kW	75 kW to 2700 kW	2.2 kW to 6600 kW	0.55 kW to 132 kW	0.05 kW to 7 kW	0.55 kW to 5700 kW	75 kW to 1200 kW	6 kW to 30 MW	0.15 MW to 85 MW
Pumps, fans, compressors, conveyor belts, mixers, mills, spinning machines, textile machines, refrigerated display counters, fitness equipment, ventilation systems	Handling machines, packaging machines, automatic assembly machines, metal forming machines, printing machines, winding and unwinding units	Pumps, fans, compressors, conveyor belts, mixers, mills, extruders, building management systems, process industry, HVAC, single-axis positioning applications in machine and plant engineering	Conveyor technology, single-axis positioning applications (G120D)	Pumps, fans, compressors, conveyor belts, mixers, mills, extruders	Sector-specific for pumps, fans, compressors, conveyor belts, extruders, mixers, mills, kneaders, centrifuges, separators	Single-axis positioning applications in machine and plant engineering	Packaging machines, handling equipment, feed and withdrawal devices, stacking units, automatic assembly machines, laboratory automation, wood, glass and ceramics industry, digital printing machines	Production machines (packaging, textile and printing machines, paper machines, plastic processing machines), machine tools, plants, process lines and rolling mills, marine drives, test bays	Test bays, cross cutters, centrifuges	Rolling mill drives, wire-drawing machines, extruders and kneaders, cableways and lifts, test bay drives	Pumps, fans, compressors, mixers, extruders, mills, crushers, rolling mills, conveyor technology, excavators, test bays, marine drives, blast furnace fans, retrofit
Catalog D 31.1	Catalog D 33	Catalogs D 31.1, D 31.5, D 31.6	Catalog D 31.2	Catalog D 11	Catalog D 18.1	Catalog D 31.1	Catalog D 32	Catalogs D 21.3, D 21.4, NC 62	Catalog D 21.3	Catalog D 23.1	Catalogs D 15.1, D 12
Engineering tools (e.g. Drive Technology Configurator, SIZER for Siemens Drives, STARTER and SINAMICS Startdrive)											

G_D011_EN_00450m

System overview

Drive selection

1

Overview

SINAMICS selection guide – typical applications

Use	Requirements for torque accuracy/speed accuracy/position accuracy/coordination of axes/functionality					
	Continuous motion			Non-continuous motion		
	Basic	Medium	High	Basic	Medium	High
Pumping, ventilating, compressing 	Centrifugal pumps Radial / axial fans Compressors V20 G120C G120X, G120XA	Centrifugal pumps Radial / axial fans Compressors G120X, G120XA G130/G150 G180 ¹⁾	Eccentric screw pumps S120	Hydraulic pumps Metering pumps G120	Hydraulic pumps Metering pumps S110	Descaling pumps Hydraulic pumps S120
Moving 	Conveyor belts Roller conveyors Chain conveyors V20 G110D G110M G120C ET 200pro FC-2 ²⁾	Conveyor belts Roller conveyors Chain conveyors Lifting/ lowering devices Elevators Escalators/ moving walkways Indoor cranes Marine drives Cable railways G120 G120D G130/G150 G180 ¹⁾	Elevators Container cranes Mining hoists Excavators for open-cast mining Test bays S120 S150 DCM	Acceleration conveyors Storage and retrieval machines V90 G120 G120D	Acceleration conveyors Storage and retrieval machines Cross cutters Reel changers S110 S210 DCM	Storage and retrieval machines Robotics Pick & place Rotary indexing tables Cross cutters Roll feeds Engagers/ disengagers S120 S210 DCM
Processing 	Mills Mixers Kneaders Crushers Agitators Centrifuges V20 G120C	Mills Mixers Kneaders Crushers Agitators Centrifuges Extruders Rotary furnaces G120 G130/G150 G180 ¹⁾	Extruders Winders/unwinders Lead/follower drives Calenders Main press drives Printing machines S120 S150 DCM	Tubular bagging machines Single-axis motion control such as • Position profiles • Path profiles V90 G120	Tubular bagging machines Single-axis motion control such as • Position profiles • Path profiles S110 S210	Servo presses Rolling mill drives Multi-axis motion control such as • Multi-axis positioning • Cams • Interpolations S120 S210 DCM
Machining 	Main drives for • Turning • Milling • Drilling S110	Main drives for • Drilling • Sawing S110 S120	Main drives for • Turning • Milling • Drilling • Gear cutting • Grinding S120	Axis drives for • Turning • Milling • Drilling S110	Axis drives for • Drilling • Sawing S110 S120	Axis drives for • Turning • Milling • Drilling • Lasering • Gear cutting • Grinding • Nibbling and punching S120

Using the SINAMICS selection guide

The varying range of demands on modern variable frequency drives requires a large number of different types. Selecting the optimum drive has become a significantly more complex process. The application matrix shown simplifies this selection process considerably, by suggesting the ideal SINAMICS drive for examples of typical applications and requirements.

- The application type is selected from the vertical column
 - Pumping, ventilating, compressing
 - Moving
 - Processing
 - Machining
- The quality of the motion type is selected from the horizontal row
 - Basic
 - Medium
 - High

More information





Further information about SINAMICS is available on the Internet at www.siemens.com/sinamics

Practical application examples and descriptions are available on the Internet at www.siemens.com/sinamics-applications

¹⁾ Industry-specific converters.

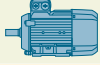
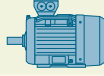
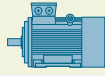
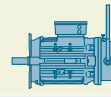
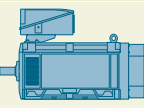
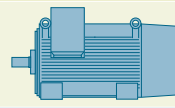
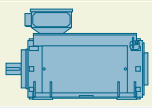
²⁾ Information on the SIMATIC ET 200pro FC-2 frequency converter is available in Catalog D 31.2 and at www.siemens.com/et200pro-fc

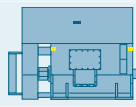
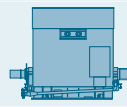
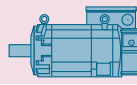
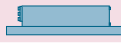
Overview

SIMOTICS						
Low-voltage motors for line and converter operation						
General Purpose SIMOTICS GP	Severe Duty SIMOTICS SD	Explosion-proof SIMOTICS XP	Definite Purpose SIMOTICS DP	Flexible Duty SIMOTICS FD	Non standard SIMOTICS TN	High Torque SIMOTICS HT
						
DC motors		High-voltage motors				
Direct current SIMOTICS DC		High Voltage SIMOTICS HV				
						
Motors for motion control						
SIMOTICS S servomotors		SIMOTICS M main motors		SIMOTICS L linear motors		SIMOTICS T torque motors
Servomotors	Servo geared motors					

G.D011_EN_09491

SIMOTICS stands for

- 150 years of experience in building electric motors
- The most comprehensive range of motors worldwide
- Optimum solutions in all industries, regions and power/performance classes
- Innovative motor technologies of the highest quality and reliability
- Highest dynamic performance, precision and efficiency together with the optimum degree of compactness
- Our motors can be integrated into the drive train as part of the overall system
- A global network of skill sets and worldwide service around the clock

A clearly structured portfolio

The entire SIMOTICS product portfolio is transparently organized according to application-specific criteria in order to help users select the optimum motor for their application.

The product range extends from standard motors for pumps, fans and compressors to highly dynamic, precise motion control motors for positioning tasks and motion control in handling applications, as well as production machinery and machine tools, to DC motors and powerful high-voltage motors. Whatever it is that you want to move – we can supply the right motor for the task.

www.siemens.com/simotics

An outstanding performance for any job

A key characteristic of all SIMOTICS motors is their quality. They are robust, reliable, dynamic and precise to assure the requisite performance level for any process and deliver exactly the capabilities demanded by the application in hand. Thanks to their compact design, they can be integrated as space-saving units into installations. Furthermore, their impressive energy efficiency makes them effective as a means of reducing operating costs and protecting the environment.

A dense network of skill sets and servicing expertise around the world

SIMOTICS offers not only a wealth of sound experience gleaned from a development history which stretches back over around 150 years, but also the know-how of hundreds of engineers. This knowledge and our worldwide presence form the basis for a unique proximity to industries which feeds through in tangible terms to the specific motor configuration which is tailored to suit your application.

Our specialists are available to answer all your queries regarding any aspect of motor technology. At any time – wherever you are in the world. When you choose SIMOTICS, therefore, you reap the benefits of a global service network which is continuously accessible, thereby helping to optimize response times and minimize downtimes.







Perfection of the complete drive train

SIMOTICS is perfectly coordinated with other Siemens product families. In combination with the SINAMICS integrated drives family and the SIRIUS complete portfolio of industrial controls, SIMOTICS fits seamlessly as part of the complete drive train into automation solutions which are based on the SIMATIC, SIMOTION and SINUMERIK control systems.

System overview

SIMOTICS low-voltage motors for line and converter operation

Overview

Low-voltage motors for mains and converter operation						
General Purpose SIMOTICS GP	Severe Duty SIMOTICS SD	Explosion Proof SIMOTICS XP	Definite Purpose SIMOTICS DP	Transnom SIMOTICS TN	Flexible Duty SIMOTICS FD	High Torque SIMOTICS HT
						
IEC: 0.09 ... 45 kW Reluctance: 0.55 ... 48 kW NEMA: 1 ... 20 hp	IEC: 0.09 ... 315 kW Reluctance: 0.55 ... 48 kW NEMA: 1 ... 400 hp	IEC: 0.09 ... 1 000 kW NEMA: 1 ... 300 hp	IEC: 0.09 ... 481 kW NEMA: 1 ... 250 hp	200 ... 3 500 kW	200 ... 1 800 kW	150 ... 2 100 kW
IEC: 0.61 ... 293.8 Nm Reluctance: 3.5 ... 191 Nm NEMA: 1.5 ... 60 lb-ft	IEC: 1.3 ... 2 070 Nm Reluctance: 3.5 ... 191 Nm NEMA: 1.5 ... 1 483 lb-ft	IEC: 0.61 ... 8 090 Nm NEMA: 1.5 ... 1 187 lb-ft	IEC: 2.5 ... 3 142 Nm NEMA: 1.5 ... 1 104 lb-ft	800 ... 22 500 Nm	610 ... 14 600 Nm	6 000 ... 42 000 Nm
IEC: 750 ... 3 000 rpm (at 50 Hz) Reluctance: 1 500/1 800/2 610 rpm NEMA: 900 ... 3 600 rpm (at 60 Hz)	IEC: 750 ... 3 000 rpm (at 50 Hz) Reluctance: 1500/1800/2610 /3000/3600 rpm NEMA: 900 ... 3 600 rpm (at 60 Hz)	IEC: 750 ... 3 000 rpm (at 50 Hz) NEMA: 900 ... 3 600 rpm (at 60 Hz)	IEC: 750 ... 3 000 rpm (at 50 Hz) NEMA: 900 ... 3 600 rpm (at 60 Hz)	IEC: 750 ... 3 000 rpm (at 50 Hz)	IEC: 750 ... 3 000 rpm (at 50 Hz)	IEC: 200 ... 800 rpm (at 50 Hz)
Pumps, fans and compressors with especially low weight requirements	Pumps, fans, compressors, mixers, mills, extruders and rollers with special demands in terms of ruggedness, particularly in the chemical and petrochemical industries	General industrial applications with special requirements regarding explosion protection for use in Zones 1, 2, 21, and 22 such as in the process industry	Ships, work and transport roller tables, tunnels, multi-story car parks, shopping malls, dockside cranes, container terminals as well as motors customized for special applications	Pumps, fans, compressors, conveyor belts, mixers, extruders in the chem. and petrochem. industry, paper-making machines, mining, cement, steel industry, and marine applications including propulsion	Pumps, fans, compressors, conveyor belts, centrifuges, extruders, winders, hoisting gear in cranes, presses, paper machines, rolling mills, marine applications including propulsion	High-torque gearless motors for paper-making machines, low-speed pumps, mills, steel shears, bow thrusters, winches or main drives on ships
IEC: D 81.1 NEMA: D 81.2	IEC: D 81.1 NEMA: D 81.2	IEC: D 81.1, D 83.1 NEMA: D 81.2	IEC: D 81.1 NEMA: D 81.2	D 81.1, D 84.1	D 81.8	D 86.2

G_D011_EN_00565

SIMOTICS GP and SIMOTICS SD

SIMOTICS GP General Purpose motors with an aluminum housing are suitable for a wide range of standard drive tasks in industrial environments. SIMOTICS SD Severe Duty motors with a cast-iron housing are extremely rugged and are therefore the first choice for applications in harsh environmental conditions.

SIMOTICS GP and SIMOTICS SD are fundamentally optimized for line operation. In addition, two converter-optimized motor lines are available for variable-speed converter-fed operation.

• Induction technology (VSD10 line)

The VSD10 line converter motors are designed exclusively for use on converters and are specially optimized for SINAMICS frequency converters. In terms of economy, efficiency and reliability, they are perfectly matched to SINAMICS G120 standard converters over the complete life cycle.

• Synchronous reluctance technology (VSD4000 line)

VSD4000 line reluctance motors are designed exclusively for use on converters and are specially optimized for SINAMICS G120. Compared to systems with induction motors, synchronous reluctance technology is characterized by particularly high efficiency levels, especially in the partial load range, and by high dynamics. The vector control of the frequency converter ensures optimal operating characteristics. More information on the reluctance drive system is available at

www.siemens.com/reluctance-drive-system

Overview

Step by step to more efficiency

One of the core objectives of the European Union is a sustainable power industry. In industrial plants today, around 70 % of the power demand is from electrically driven systems. This high percentage contains huge potential for saving energy in electrical drives. For that reason, the European Union introduced minimum requirements for the energy efficiency of electric motors in the form of a statutory motor regulation as early as 2011.

However, measures aimed solely at the motor are not enough to achieve the mandatory energy-saving targets. The European legislation fills this gap with the standard series EN 50598 and extends the focus from individual drive components to entire drive systems, even enabling consideration of specific use cases.

The European standard series EN 50598 defines the ecodesign requirements for drive systems in the low-voltage range with an electrically driven machine. It consists of definitions for energy efficiency (parts 1 and 2) and an ecobalance calculation (part 3).

To take account of the different use cases, consideration of eight application-relevant operating points has been introduced as mandatory for the first time. Determination of loss values at these eight points and definition of efficiency classes are laid down by the standard in a uniform way. This enables data relevant to operation, such as application-specific load profiles, to now be taken into account more easily in the energy efficiency analysis.

The standard is especially important for variable-speed drives of the following types:

- for AC/AC converters without energy recovery functionality
- for motors with integrated converters
- for supply voltages of 100 V to 1000 V
- for power ratings of 0.12 kW to 1000 kW

To cover all applications of driven machines, the new standard defines operating points in full-load and partial-load operation, at which the losses of the motor and drive systems have to be determined. Based on the loss data at the operating points in partial-load operation, variable-speed drives can be explicitly considered in more detail. This makes their advantages especially clear.

Centrifugal pumps, fans

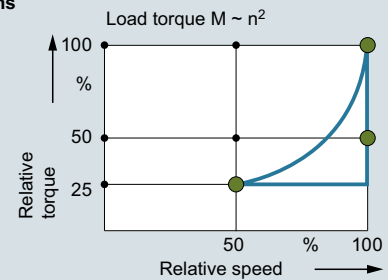

Hoisting gear, extruders, conveyor belts

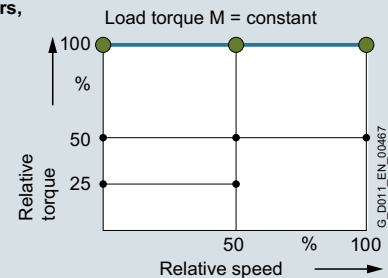

Winders, coilers

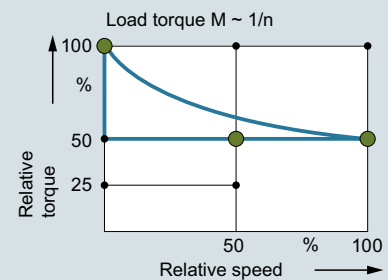

Duty cycles for different driven machines

Moreover, frequency converters and motor systems are classified in efficiency classes, which permit an initial rough estimate of the potential saving. Definition of reference systems is a key aspect of this because they provide standard reference values. The positioning of these reference systems defines the efficiency class. The relative distance from the reference system can be used as an absolute measure of the efficiency at the operating point in question.

System overview

1

Energy efficiency classes in accordance with EN 50598

Overview (continued)

Advantages of the detailed loss consideration of EN 50598 over the previous consideration of efficiencies and maximum loss values

For motors, the efficiency consideration was previously only defined for operation without a converter at 50/60 Hz. It provides a good way of comparing the energy efficiency of motors from different manufacturers for this use case.

The more detailed loss analysis of EN 50598, on the other hand, is aimed at speed-controlled operation and therefore now also includes motors especially designed for converter operation in the energy analysis. These were previously not covered by the applicable standards.

Moreover, a loss analysis over the entire setting and load range of the motor is possible. This is done in accordance with the standard EN 50598 with typical values.

For holistic consideration, it is essential to include all the relevant components of a drive system. The EN 50598 standard defines this in detail. The standardized expression of power loss data as a percentage makes comparison considerably easier and more transparent.

The method also makes it possible to consider a motor that produces a holding torque at speed zero, for example. In this case, the efficiency is zero, but a power loss from current producing magnetization and holding torque does occur. In summary, the key advantage of standard EN 50598 is the ability to perform the energy analysis of an electrical drive system based on standardized load profiles in all operating ranges due to uniform general conditions. This provides the user with complete transparency irrespective of the manufacturer.

Establishing efficiency classes of frequency converters (Complete Drive Modules CDM)

To avoid overmodulation and to ensure comparability between makes, which cannot be achieved otherwise, the efficiency classes of CDMs refer to the 90/100 operating point (90 % motor stator frequency, 100 % torque current).

Standard EN 50598-2 defines the relative losses of a CDM in efficiency classes IE0 to IE2. With reference to the value of a CDM of efficiency class IE1 (reference converter), a CDM of efficiency class IE2 has 25 % lower losses and a CDM of efficiency class IE0 has 25 % higher losses.

Operating points for CDMs

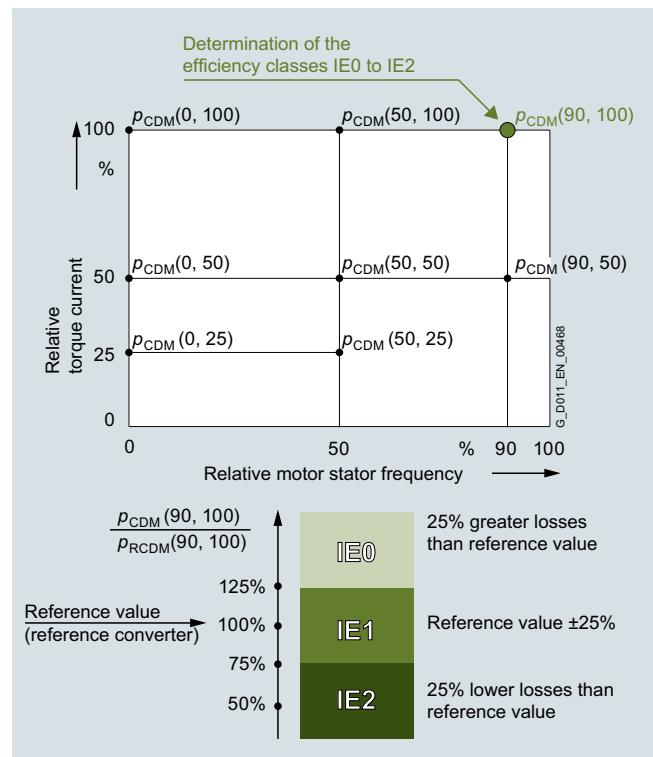

Complete Drive Module (CDM) – determining the efficiency class

Establishing the efficiency classes of drive systems (Power Drive Systems PDS)

What is possible for the individual systems, of course, also applies to the entire electrical PDS (frequency converter plus motor). Detailed comparisons are now possible at this level, too. The reference values for the reference system provide clear indications of the energy performance of the PDS.

Because targeted matching of the motor and CDM provides additional potential for optimization in electrical drive systems, it is especially important for the user to consider the entire drive system.

For the efficiency class of a PDS, too, a specific load point is defined. In this case, the reference point used is the 100/100 operating point (100 % motor stator frequency, 100 % torque).

Standard EN 50598-2 defines the relative losses of a PDS in efficiency classes IES0 to IES2. With reference to the value of a PDS of efficiency class IES1 (reference drive), a PDS of efficiency class IES2 has 20 % lower losses and a PDS of efficiency class IES0 has 20 % higher losses.

Energy efficiency classes in accordance with EN 50598

Overview (continued)

Operating points for PDS

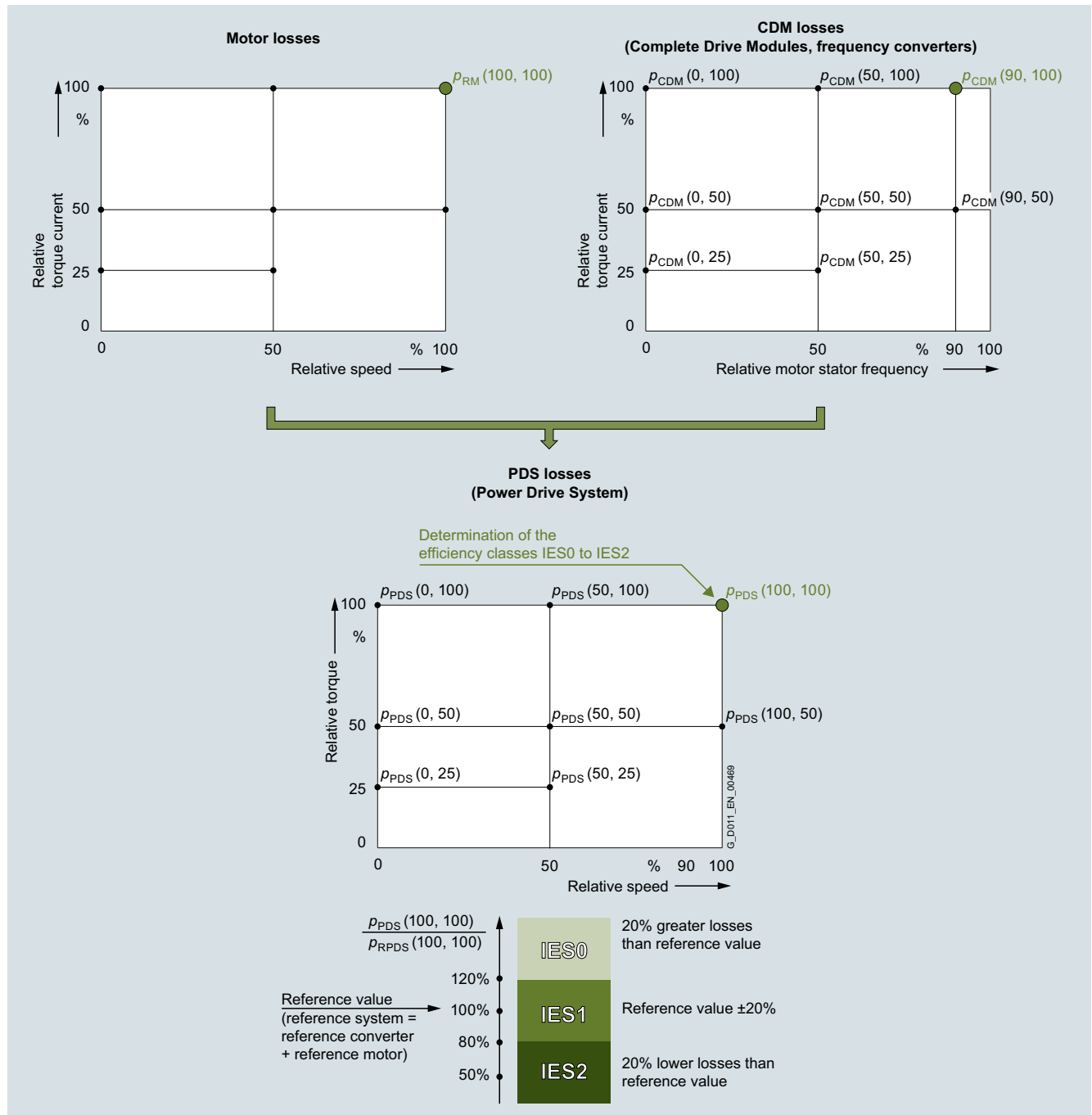

Power Drive System (PDS) – determining the efficiency class

More information

An example of a highly efficient drive system with efficiency class IES2 is the new synchronous inductance drive system with SIMOTICS reluctance motors and SINAMICS drives. More information is available on the Internet at www.siemens.com/drivesystem-reluctance, www.siemens.com/simotics-gp, www.siemens.com/simotics-sd

Power loss data of SINAMICS converters for single-axis drives are available on the Internet at <https://support.industry.siemens.com/cs/document/94059311>

More information on current laws and standards, new standards, and mandatory guidelines is available on the Internet at www.siemens.com/legislation-and-standards

System overview

SINAMICS G120XA Starter Kit

Overview

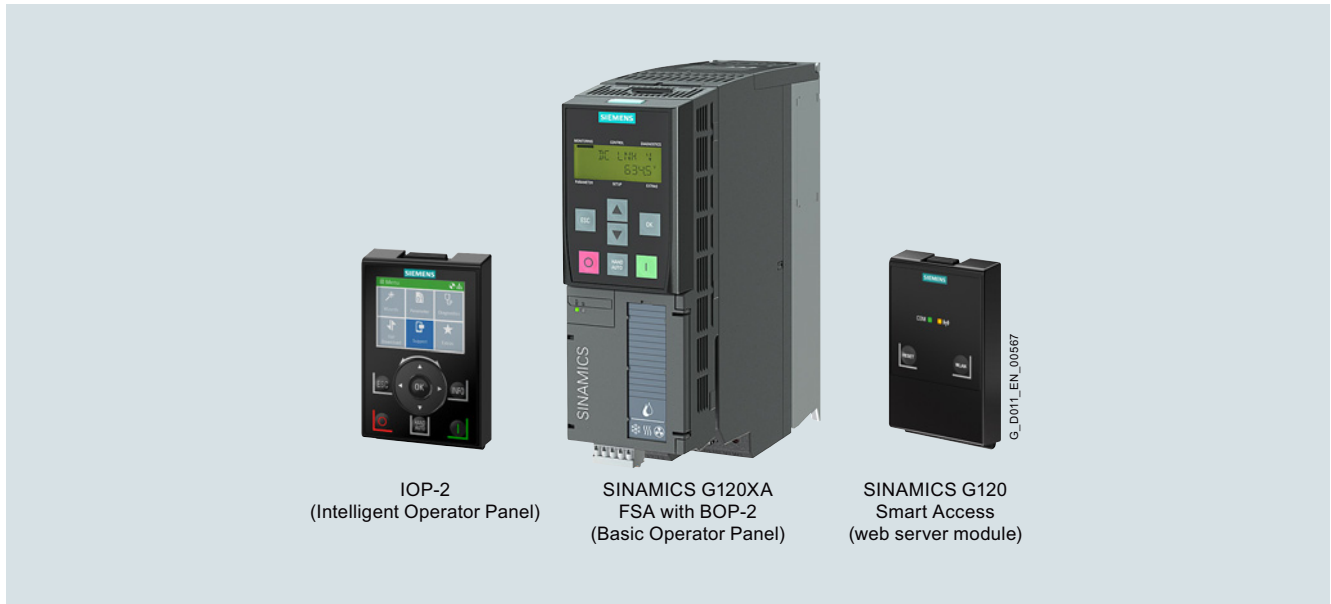

IOP-2
(Intelligent Operator Panel)

SINAMICS G120XA
FSA with BOP-2
(Basic Operator Panel)

SINAMICS G120
Smart Access
(web server module)

SINAMICS G120XA Starter Kit

The SINAMICS G120XA Starter Kit comprises a SINAMICS G120XA converter (380 ... 440 V 3 AC, USS, Modbus RTU, BACnet MS/TP, FSA, 0.75 kW) with a BOP-2 Basic Operator Panel, an IOP-2 Intelligent Operator Panel and a web server module SINAMICS G120 Smart Access.

The delivery quantity is limited to three per customer.

The SINAMICS G120XA Starter Kits can be perfectly combined with the SIMATIC Starter Kits. In this way simple drive tasks up to motion control applications can be quickly implemented.

Further information on SIMATIC Starter Kits can be found at:
www.siemens.com/s7-1200-starterkits
www.siemens.com/s7-1500-starterkits

Selection and ordering data

Description	Article No.
SINAMICS G120XA Starter Kit (available soon) <ul style="list-style-type: none"> • 380 ... 440 V 3 AC converter, USS, Modbus RTU, BACnet MS/TP, FSA, 0.75 kW • BOP-2 • IOP-2 • SINAMICS G120 Smart Access 	6SL3200-0AE71-0AA0

SINAMICS G120XA infrastructure converters for standard pumps/fans

0.75 kW to 560 kW

2



2/2

SINAMICS G120XA infrastructure converters for standard pumps/fans

2/2 Integration

2/4 Selection and ordering data

2/2

- SINAMICS G120XA converters · Degree of protection IP20, IP00 for frame size FSJ · 380 ... 440 V 3 AC
- Configuration with line- and load-side components

2/5

2/6 Technical specifications

2/10 Configuration

2/11 Characteristic curves

2/13 Dimensional drawings

2/13 More information

2/14

Supplementary system components

2/14

Operator Panels

2/15

IOP-2 Intelligent Operator Panel

2/18

BOP-2 Basic Operator Panel

2/19

Memory cards

2/20

SINAMICS G120 Smart Access

2/21

Shield connection kits for Power Module

2/22

Spare parts

2/22

FPI board for frame sizes FSH and FSJ

2/22

PSB board for frame sizes FSH and FSJ

2/22

Current transformers

for frame sizes FSH and FSJ

2/22

Spare parts kit for Control Unit

2/22

Shield connection kit for Control Unit

2/23

Shield connection kits for Power Module

2/23

Mounting set for frame sizes FSD to FSG

2/23

Terminal cover kits

for frame sizes FSD to FSG

2/24

Fan units

Further information about SINAMICS G120XA can be found on the Internet at www.siemens.com.cn/sinamics-g120xa

SINAMICS G120XA infrastructure converters for standard pumps/fans

0.75 kW to 560 kW

SINAMICS G120XA infrastructure converters for standard pumps/fans

Integration

2

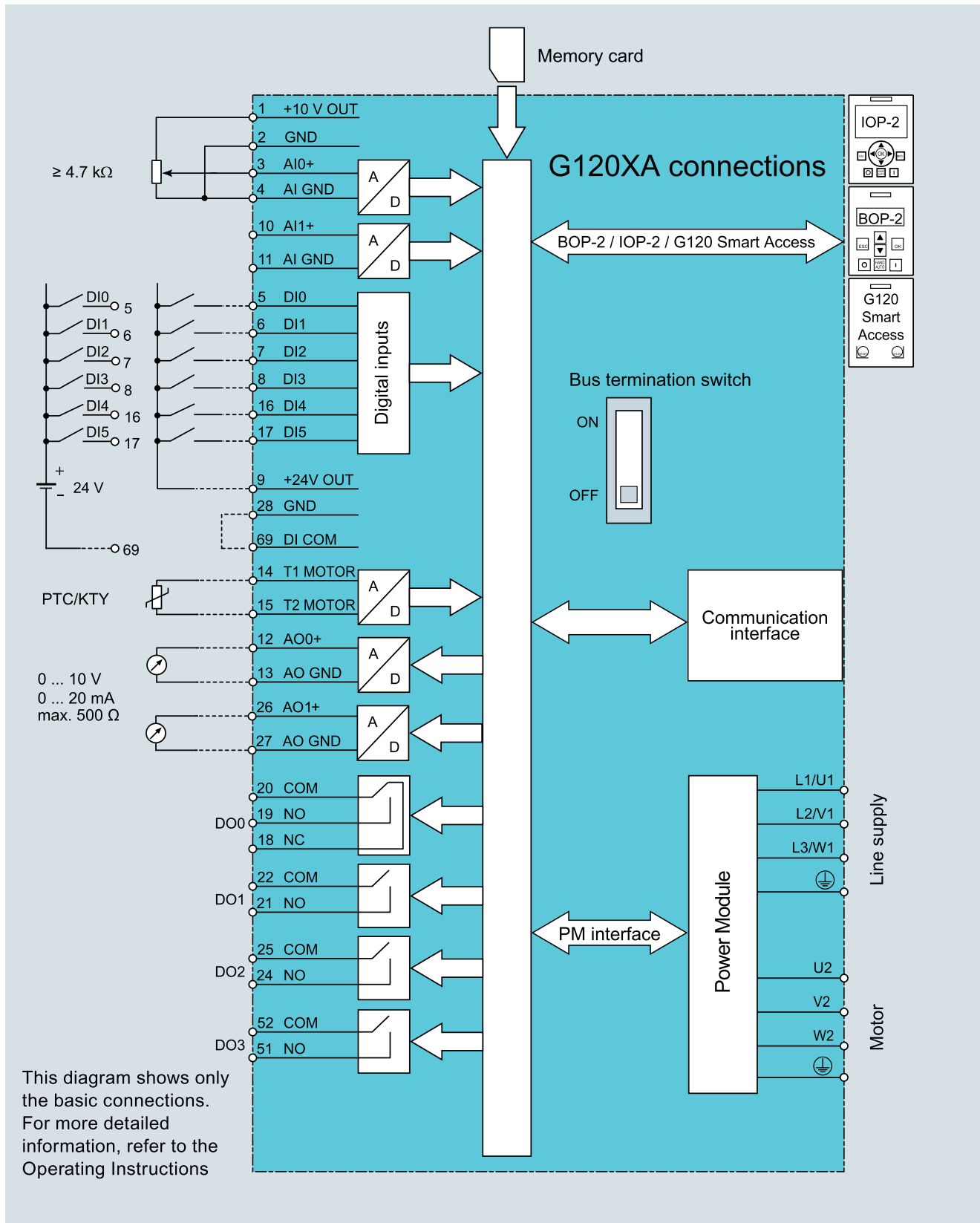

Block diagram SINAMICS G120XA

SINAMICS G120XA infrastructure converters for standard pumps/fans

0.75 kW to 560 kW

SINAMICS G120XA infrastructure converters for standard pumps/fans

Integration (continued)

Control Unit interfaces

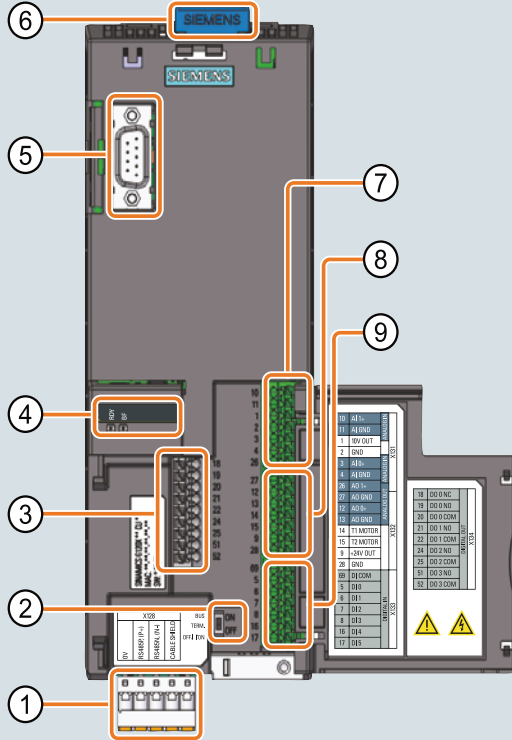

1	USS, Modbus RTU, BACnet MS/TP interfaces
2	Bus termination switch
3	Terminal strip X134
4	Status LEDs
5	Interface X21 to operator panel or SINAMICS G120 Smart Access
6	Memory card slot
7	Terminal strip X131
8	Terminal strip X132
9	Terminal strip X133

USS, Modbus RTU, BACnet MS/TP interfaces

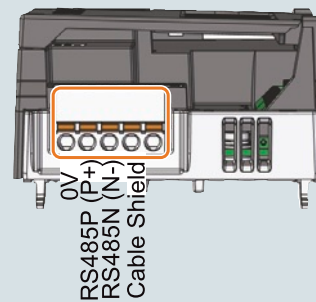

Terminals (factory settings)

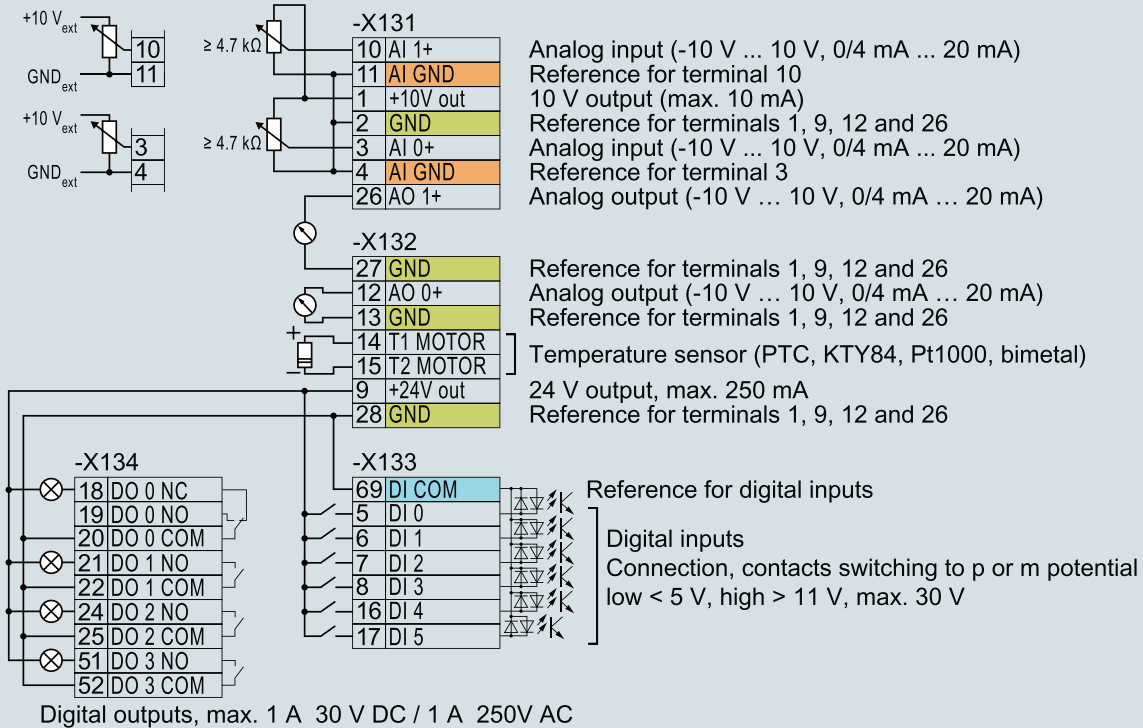

Connection example for SINAMICS G120XA

SINAMICS G120XA infrastructure converters for standard pumps/fans

0.75 kW to 560 kW

SINAMICS G120XA infrastructure converters for standard pumps/fans

Selection and ordering data

SINAMICS G120XA converters · Degree of protection IP20, IP00 for frame size FSJ ⇒ Configuration with line- and load-side components (see right page)

Rated power ¹⁾ 400 V kW	Rated output current I_{rated} ²⁾ 400 V A	Rated input current ³⁾ 400 V A	Frame size	SINAMICS G120XA Degree of protection IP20, IP00 for frame size FSJ without integrated line filter	SINAMICS G120XA Degree of protection IP20, IP00 for frame size FSJ with integrated line filter
				Converters up to 132 kW delivery ex stock	Converters up to 15 kW delivery ex stock
				10 ... 48 Article No. ↓↓	10 ... 28 Article No. ↓↓
380 ... 440 V 3 AC · Rated pulse frequency 4 kHz ≤ 90 kW and 2 kHz ≥ 110 kW · Input frequency 47 ... 63 Hz					
0.75	2.2	2.1	FSA	6SL32 2 0- ■ YD10- 0 U B 0	6SL32 2 0- ■ YD10- 0 C B 0
1.1	3.1	2.8	FSA	6SL32 2 0- ■ YD12- 0 U B 0	6SL32 2 0- ■ YD12- 0 C B 0
1.5	4.1	3.6	FSA	6SL32 2 0- ■ YD14- 0 U B 0	6SL32 2 0- ■ YD14- 0 C B 0
2.2	5.6	5.3	FSA	6SL32 2 0- ■ YD16- 0 U B 0	6SL32 2 0- ■ YD16- 0 C B 0
3	7.3	6.6	FSA	6SL32 2 0- ■ YD18- 0 U B 0	6SL32 2 0- ■ YD18- 0 C B 0
4	8.8	8.5	FSB	6SL32 2 0- ■ YD20- 0 U B 0	6SL32 2 0- ■ YD20- 0 C B 0
5.5	12.5	11.5	FSB	6SL32 2 0- ■ YD22- 0 U B 0	6SL32 2 0- ■ YD22- 0 C B 0
7.5	16.5	15.8	FSB	6SL32 2 0- ■ YD24- 0 U B 0	6SL32 2 0- ■ YD24- 0 C B 0
11	25	25.8	FSC	6SL32 2 0- ■ YD26- 0 U B 0	6SL32 2 0- ■ YD26- 0 C B 0
15	31	28.5	FSC	6SL32 2 0- ■ YD28- 0 U B 0	6SL32 2 0- ■ YD28- 0 C B 0
18.5	37	41	FSD	6SL32 2 0- ■ YD30- 0 U B 0	6SL32 2 0- ■ YD30- 0 C B 0
22	43	46	FSD	6SL32 2 0- ■ YD32- 0 U B 0	6SL32 2 0- ■ YD32- 0 C B 0
30	58	56	FSD	6SL32 2 0- ■ YD34- 0 U B 0	6SL32 2 0- ■ YD34- 0 C B 0
37	68	73	FSD	6SL32 2 0- ■ YD36- 0 U B 0	6SL32 2 0- ■ YD36- 0 C B 0
45	82.5	84	FSD	6SL32 2 0- ■ YD38- 0 U B 0	6SL32 2 0- ■ YD38- 0 C B 0
55	103	106	FSE	6SL32 2 0- ■ YD40- 0 U B 0	6SL32 2 0- ■ YD40- 0 C B 0
75	136	143	FSF	6SL32 2 0- ■ YD42- 0 U B 0	6SL32 2 0- ■ YD42- 0 C B 0
90	164	164	FSF	6SL32 2 0- ■ YD44- 0 U B 0	6SL32 2 0- ■ YD44- 0 C B 0
110	201	200	FSF	6SL32 2 0- ■ YD46- 0 U B 0	6SL32 2 0- ■ YD46- 0 C B 0
132	237	234	FSF	6SL32 2 0- ■ YD48- 0 U B 0	6SL32 2 0- ■ YD48- 0 C B 0
160	289	278	FSG	–	6SL32 2 0- ■ YD50- 0 C B 0
200	364	348	FSG	–	6SL32 2 0- ■ YD52- 0 C B 0
250	436	417	FSG	–	6SL32 2 0- ■ YD54- 0 C B 0
315	590	617	FSH	–	6SL32 2 0- ■ YD56- 0 C B 0
355	645	684	FSH	–	6SL32 2 0- ■ YD58- 0 C B 0
400	725	760	FSH	–	6SL32 2 0- ■ YD60- 0 C B 0
450	820	870	FSJ	–	6SL32 2 5- ■ YD62- 0 C B 0
500	895	959	FSJ	–	6SL32 2 5- ■ YD64- 0 C B 0
560	1015	1060	FSJ	–	6SL32 2 5- ■ YD66- 0 C B 0

Article No. supplements

Environmental class/harmful chemical substances acc. to EN 60721-3-3

Class 3C2 – **delivery ex stock**

Operator Panel

Without Operator Panel *

With BOP-2 Basic Operator Panel (numeric 2-line display) – **delivery ex stock**

With IOP-2 Intelligent Operator Panel (graphic color display) *

Line filter

Without integrated line filter – **delivery ex stock**

With integrated line filter Category C3 – **delivery ex stock**

Communication

USS, Modbus RTU, BACnet MS/TP – **delivery ex stock**

* If you select one of these supplements, the delivery time for converters without integrated line filter up to 132 kW or with integrated line filter up to 15 kW will change from "delivery ex stock" to "standard delivery time".

2

1) Rated power based on the rated output current I_{rated} . The rated output current I_{rated} is based on the duty cycle for low overload (LO).
 2) The rated output current I_{rated} is based on the duty cycle for low overload (LO). These current values are valid for 400 V and are specified on the rating plate of the converter.

3) The input current depends on the motor load and line impedance. The input currents apply for a load at rated power (based on I_{rated}) for a line impedance corresponding to $u_k = 1\%$. The current values are specified on the rating plate of the converter.

SINAMICS G120XA infrastructure converters for standard pumps/fans

0.75 kW to 560 kW

SINAMICS G120XA infrastructure converters for standard pumps/fans



Line-side components			Load-side power components	
Line reactors	Recommended line-side overcurrent protection devices		Output reactors	dv/dt filters plus VPL
	Fuses IEC-compliant Further information at https://support.industry.siemens.com/cs/cn/en/view/109762896			
Article No.	Current A	Article No.	Article No.	Article No.
A DC link reactor is integrated for frame sizes FSA to FSG – therefore no line reactor is required.	10	3NA3803	A DC link reactor is integrated for frame sizes FSA to FSC – therefore long cable lengths are possible without output reactors.	–
	16	3NA3805		–
	16	3NA3805		–
	16	3NA3805		–
	16	3NA3805		–
	32	3NA3812		–
	32	3NA3812		–
	32	3NA3812		–
	50	3NA3820		–
	50	3NA3820		–
	63	3NA3822	6SL3202-0AE23-8CA0	–
	80	3NA3824	6SE6400-3TC07-5ED0	–
	100	3NA3830		–
	100	3NA3830		–
	125	3NA3832	6SE6400-3TC14-5FD0	–
160	3NA3836		–	
200	3NA3140		–	
224	3NA3142		–	
300	3NA3250	6SL3000-2BE32-1AA0	–	
315	3NA3252	6SL3000-2BE32-6AA0	–	
355	3NA3254	6SL3000-2BE33-2AA0	–	
400	3NA3260	6SL3000-2BE33-8AA0	–	
630	3NA3372	6SL3000-2BE35-0AA0	–	
6SL3000-0CE36-3AA0	630	3NE1437-2	6SL3000-2AE36-1AA0	6SL3000-2DE38-4AA0
6SL3000-0CE37-7AA0	800	3NE1438-2	6SL3000-2AE38-4AA0	
	850	3NE1448-2		
6SL3000-0CE38-7AA0	2 × 500	3NE1334-2 2 fuses	6SL3000-2AE41-0AA0	6SL3000-2DE41-4AA0
6SL3000-0CE41-0AA0	2 × 560	3NE1435-2 2 fuses		
	2 × 630	3NE1436-2 2 fuses		

Ordering examples

Basic selection	Example 1	Example 2
SINAMICS G120XA converters · degree of protection IP20 · 380 ... 440 V 3 AC, 15 kW · with integrated line filter – converters up to 15 kW delivery ex stock	6SL32 2 0- 2 YD28- 0 C B 0	6SL32 2 0- 3 YD28- 0 C B 0
Article No. supplements		
Environmental class/harmful chemical substances acc. to EN 60721-3-3 Class 3C2 – delivery ex stock	2	2
Operator Panel With BOP-2 Basic Operator Panel (numeric 2-line display) – delivery ex stock With IOP-2 Intelligent Operator Panel (graphic color display) *	2	3
Line filter With integrated line filter Category C3 – delivery ex stock	C	C
Communication USS, Modbus RTU, BACnet MS/TP – delivery ex stock	B	B
Complete Article No.	6SL32 2 0- 2 YD28- 0 C B 0 Delivery ex stock	6SL32 2 0- 3 YD28- 0 C B 0 Standard delivery time

* If you select one of these supplements, the delivery time for converters without integrated line filter up to 132 kW or with integrated line filter up to 15 kW will change from "delivery ex stock" to "standard delivery time".

SINAMICS G120XA infrastructure converters for standard pumps/fans

0.75 kW to 560 kW

SINAMICS G120XA infrastructure converters for standard pumps/fans

Technical specifications

Unless explicitly specified otherwise, the following technical specifications are valid for all SINAMICS G120XA converters.

General technical specifications	
Mechanical specifications	
Shock and vibration load	
<ul style="list-style-type: none"> Frame sizes FSA to FSG <ul style="list-style-type: none"> Transport in transport packaging acc. to EN 61800-5-1 and EN 60068-2-6 Vibration during operation acc. to EN 60721-3-3: 1995 Frame sizes FSH and FSJ <ul style="list-style-type: none"> Vibration during operation: Test Fc acc. to EN 60068-2-6 Shock during operation: Test acc. to EN 60068-2-27 Vibration in product packaging: Test Fc acc. to EN 60068-2-64 Shock in product packaging: Test Fc acc. to EN 60068-2-27 	Class 2M3 Class 3M1 0.075 mm at 10 ... 58 Hz 9.81 m/s ² (1 × g) at > 58 ... 200 Hz 100 m/s ² (10 × g)/11 ms 30 min/axis, 3 axes 10 ... 200 Hz ASD 1.0 (m ² /s ³) 10 × g/11 ms
Degree of protection	
<ul style="list-style-type: none"> Frame sizes FSA to FSH Frame size FSJ 	IP20/ UL Open Type IP00/ UL Open Type
Permissible mounting position	Vertical wall mounting
Ambient conditions	
Protection class According to EN 61800-5-1	Class III (PELV1) for Power Module Class II (PELV1) for Control Unit
Touch protection According to EN 61800-5-1	Class I (with protective conductor system)
Humidity, max.	<95 %, condensation not permissible
Ambient temperature	
<ul style="list-style-type: none"> Storage acc. to EN 60068-2-1 <ul style="list-style-type: none"> Frame sizes FSA to FSG Frame sizes FSH and FSJ Transport acc. to EN 60068-2-1 Operation acc. to EN 60068-2-2 <ul style="list-style-type: none"> Frame sizes FSA to FSG Frame sizes FSH and FSJ All frame sizes with operator panel 	-40 ... +70 °C (-40 ... +158 °F) -25 ... +55 °C (-13 ... +131 °F) -40 ... +70 °C (-40 ... +158 °F) -20 °C ... +60 °C (-4 ... +140 °F) with a side clearance of 5 cm or -20 °C ... +55 °C (-4 ... +131 °F) for side-by-side mounting, >40 °C (104 °F) with derating 0 ... 50 °C (32 ... 122 °F) with derating Current derating as a function of the ambient temperature 0 ... 50 °C (32 ... 122 °F) <i>see also derating characteristics</i>
Environmental class in operation	
<ul style="list-style-type: none"> Harmful chemical substances Organic/biological pollutants Degree of pollution 	Class 3C2 acc. to EN 60721-3-3 Class 3B1 acc. to EN 60721-3-3 2 acc. to EN 61800
Standards	
Compliance with standards ¹⁾	CE, RCM, RoHS II, EAC
CE marking, according to	EMC Directive 2014/30/EU Low Voltage Directive 2014/35/EU
EMC Directive ¹⁾ acc. to EN 61800-3	
<ul style="list-style-type: none"> Interference immunity Interference emissions <ul style="list-style-type: none"> Frame sizes FSA to FSF without integrated line filter Frame sizes FSA to FSJ with integrated line filter Category C3 	The SINAMICS G120XA converters are tested according to the interference immunity requirements for environments according to Category C3. 2) Observance of the limit values according to Category C3
Note: The EMC product standard EN 61800-3 does not apply directly to a frequency converter but to a PDS (Power Drive System), which comprises the complete circuitry, motor and cables in addition to the converter. The frequency converters on their own do not generally require identification according to the EMC Directive.	

¹⁾ Additional information is available in the operating instructions on the Internet at: www.siemens.com/sinamics-g120xa/documentation

²⁾ Non-filtered devices are designed for operation in IT systems or in conjunction with an RCD. The customer must provide suitable RI suppression equipment to ensure that these devices comply with the limits defined for Category C3.

SINAMICS G120XA infrastructure converters for standard pumps/fans

0.75 kW to 560 kW

SINAMICS G120XA infrastructure converters for standard pumps/fans**Technical specifications** (continued)

SINAMICS G120XA converters	
Integrated bus interface	
Fieldbus protocols	<ul style="list-style-type: none"> • USS • Modbus RTU • BACnet MS/TP
Hardware	RS485 connected at a terminal, isolated, USS: max. 187.5 kBaud Modbus RTU: 19.2 kBaud, BACnet MS/TP: max. 187.5 kBaud, bus terminating resistor can be switched in
I/O interfaces	
Signal cable cross-section	0.15 ... 1.5 mm ² (28 ... 16 AWG)
Digital inputs	6 isolated inputs Optically isolated; Free reference potential (own potential group) NPN/PNP logic can be selected using the wiring
<ul style="list-style-type: none"> • Switching level: 0 → 1 • Switching level: 1 → 0 	11 V 5 V
Digital outputs	1 relay changeover contact 250 V AC, 1 A (inductive load), 30 V DC, 1 A (ohmic load) 3 relay NO contacts 250 V AC, 1 A (inductive load), 30 V DC, 1 A (ohmic load)
Analog inputs	2 analog inputs Differential input Switchable between voltage (-10 ... +10 V) and current (0/4 ... 20 mA) using a DIP switch 12-bit resolution Can be used as additional digital input
<ul style="list-style-type: none"> • Switching threshold: 0 → 1 • Switching threshold: 1 → 0 	4 V 1.6 V
Analog outputs	2 analog outputs Non-isolated output Switchable between voltage (0 ... 10 V) and current (0/4 ... 20 mA) using a parameter Voltage mode: 10 V, min. burden 10 kΩ Current mode: 20 mA, max. burden 500 Ω The analog outputs have short-circuit protection
PTC/KTY interface	1 motor temperature sensor input Connectable sensors PTC, Pt1000, KTY and bimetal, accuracy ±5 °C
Voltage supply for the integrated Control Unit	24 V DC via the Power Module
Tool interfaces	
Memory card	Optional SINAMICS SD card
Operator panels	Optional BOP-2 Basic Operator Panel or IOP-2 Intelligent Operator Panel or SINAMICS G120 Smart Access

SINAMICS G120XA infrastructure converters for standard pumps/fans

0.75 kW to 560 kW

SINAMICS G120XA infrastructure converters for standard pumps/fans

Technical specifications (continued)

SINAMICS G120XA converters

Open-loop/closed-loop control techniques

V/f linear/quadratic/parameterizable ✓

V/f with flux current control (FCC) ✓

V/f ECO linear/quadratic ✓

Vector control, sensorless ✓

Software functions

Setpoint input, can be parameterized ✓

Fixed frequencies 16, parameterizable

JOG ✓

Digital motorized potentiometer (MOP) ✓

Ramp smoothing ✓

Extended ramp-function generator (with ramp smoothing OFF3) ✓

Slip compensation ✓

Switchable drive data sets (DDS) ✓ (4)

Switchable command data sets (CDS) ✓ (2)

Flying restart ✓

Automatic restart after line supply failure or operating fault (AR) ✓

Technology controller (internal PID) ✓

Energy saving display ✓

3 additional, free PID controllers ✓

Hibernation mode with internal/external PID controller ✓

Belt monitoring with and without sensor (load torque monitoring) ✓

Dry-running/overload protection monitoring (load torque monitoring) ✓

Deragging ✓

Thermal motor protection ✓ (I^2t , sensor: PTC, Pt1000, KTY and bimetal)

Thermal converter protection ✓

Motor identification ✓

Auto-ramping (V_{dc_max} controller) ✓Kinetic buffering (V_{dc_min} controller) ✓

Braking functions

• DC braking ✓

• Compound braking ✓

2

SINAMICS G120XA infrastructure converters for standard pumps/fans

0.75 kW to 560 kW

SINAMICS G120XA infrastructure converters for standard pumps/fans

Technical specifications (continued)

General technical specifications of the power electronics

System operating voltage	
• Frame sizes FSA to FSG	380 ... 440 V 3 AC +10 % -20 %
• Frame sizes FSH and FSJ	380 ... 440 V 3 AC +10 % -15 %
Line supply requirements	
Line impedance u_K	
• Frame sizes FSA to FSG	2 %
• Frame sizes FSD to FSG	No restriction
• Frame sizes FSH and FSJ	A line reactor ($u_K = 2 %$) must be connected in series, if the short-circuit power ratio $R_{SC} > 33$ (315 ... 500 kW) or $R_{SC} > 20$ (560 kW)
Input frequency	47 ... 63 Hz
Output frequency	
• Frame sizes FSA to FSG	Control mode V/f: 0 ... 550 Hz Control mode Vector: 0 ... 240 Hz
• Frame sizes FSH and FSJ	Control mode V/f: 0 ... 100 Hz Control mode Vector: 0 ... 100 Hz
Pulse frequency	
• Frame sizes FSA to FSG	4 kHz for converters with a rated power ≤ 90 kW 2 kHz for converters with a rated power ≥ 110 kW Higher pulse frequencies up to 16 kHz see derating data
• Frame sizes FSH and FSJ	2 kHz Self-adjusting up to 4 kHz see derating data
Power factor λ	
• Frame sizes FSA to FSG	0.75 ... 0.93
• Frame sizes FSH and FSJ	0.75 ... 0.93 (with line reactor $u_K = 2 %$)
Offset factor $\cos \varphi$	0.99
Output voltage, max. as % of line voltage	97 %
Overload capability	
• Low overload LO	1.1 × base-load current I_L (i. e. 110 % overload) for 60 s within a cycle time of 600 s
Cooling	Air cooling using an integrated fan
Installation altitude	Up to 1000 m (3281 ft) above sea level without derating, >1000 m (3281 ft) see derating characteristics
Short Circuit Current Rating (SCCR), max.	100 kA see Recommended line-side overcurrent protection devices – the value depends on the fuses and circuit breakers used For more information, see: https://support.industry.siemens.com/cs/cn/en/view/109762896
Protection functions	<ul style="list-style-type: none"> • Undervoltage • Overvoltage • Overcurrent/overload • Ground fault • Short-circuit • Stall protection • Motor blocking protection • Motor overtemperature • Converter overtemperature • Parameter locking

Maximum permissible motor cable lengths SINAMICS G120XA

The values specified in the table below apply with low-capacitance CY cables and with pulse frequencies set in the factory.

	Maximum permissible motor cable lengths (shielded/unshielded) in m (ft)			
	FSA to FSC	FSD and FSE	FSF and FSG	FSH and FSJ
Without compliance to the EMC category				
Converters without optional power components	100/150 (328/492)	200/300 (656/984)	300/450 (984/1476)	150/200 (492/656)
Converters with optional output reactor	–	200/300 (656/984) ¹⁾	300/450 (984/1476) ¹⁾	300/450 (984/1476)
Converters with optional dv/dt filter plus VPL	–	–	–	300/450 (984/1476)
With compliance to the EMC category				
Converters with integrated line filter Category C3 to comply with radio interference emissions according to EN 61800-3 EMC Category C3	50/– (164/–)	100/– (328/–)	150/– (492/–)	100/– (328/–)

¹⁾ For frame sizes FSD to FSG the maximum permissible cable lengths are not increased with an output reactor. By means of the output reactor, the loading of the motor windings is reduced by lower rates of voltage rise (dv/dt). By means of two output reactors connected in series, the maximum permis-

sible cable lengths for frame sizes FSD and FSE are increased to 350 m (1148 ft) (shielded) and 525 m (1723 ft) (unshielded), and for frame sizes FSF and FSG to 525 m (1723 ft) (shielded) and 800 m (2625 ft) (unshielded).

SINAMICS G120XA infrastructure converters for standard pumps/fans

0.75 kW to 560 kW

SINAMICS G120XA infrastructure converters for standard pumps/fans

Configuration

The following electronic configuring aids and engineering tools are available for the SINAMICS G120XA:

Drive Technology Configurator (DT Configurator)

Drive Technology Configurator (DT Configurator) within the CA 01

The Interactive Catalog CA 01 - the offline Industry Mall of Siemens - contains over 100000 products with approximately 5 million possible drive system product variants. The Drive Technology Configurator (DT Configurator) has been developed to facilitate selection of the correct motor and/or converter from the wide spectrum of drives. It is integrated as a selection tool in Catalog CA 01.

Online DT Configurator

In addition, the DT Configurator can be used on the Internet without requiring any installation. The DT Configurator can be found in the Siemens Industry Mall at the following address:

www.siemens.com.cn/dt-configurator

You can find further information on the Drive Technology Configurator (DT Configurator) in the section Engineering tools.

SinaSave energy efficiency tool

Use SinaSave to calculate potential energy savings

The web-based tool SinaSave can be used to estimate the potential savings which can be achieved over the entire lifecycle, e.g. for pump and fan applications, thanks to SINAMICS. The tool takes into consideration all important plant-specific quantities, such as the power and load data of the application, the relevant control mode and the operation profile for the application in question. The result delivered by the tool specifies the potential energy savings which can be achieved with the specific application in conjunction with the Integrated Drive System or the drive component. The tool also provides a monetary evaluation of the potential savings and estimates the payback period.

For more information about the amortization calculator for energy-efficient drive systems, visit

www.siemens.com/sinasave

You can find further information on the SinaSave energy efficiency tool in the section Engineering tools.

SINAMICS Web server for SINAMICS G120XA via SINAMICS G120 Smart Access

Web server for efficient commissioning, diagnostics and maintenance

Thanks to the optionally available SINAMICS G120 Smart Access, the SINAMICS G120XA drive system offers a web server for efficient commissioning, diagnostics and maintenance options. The web server provides access to a multi-faceted range of new options for parameter assignment and drive diagnostics for laptops, tablets and smartphones.

You can find further information on the SINAMICS Web server for SINAMICS G120XA via SINAMICS G120 Smart Access in the section Engineering tools.

SINAMICS G120XA infrastructure converters for standard pumps/fans

0.75 kW to 560 kW

SINAMICS G120XA infrastructure converters for standard pumps/fans

Characteristic curves

Derating data

Pulse frequency

Frame size	Rated power ¹⁾ at 50 Hz 400 V 3 AC kW	Rated output current in A (at an ambient temperature of 40 °C (104 °F)) for a pulse frequency of							
		2 kHz	4 kHz	6 kHz	8 kHz	10 kHz	12 kHz	14 kHz	16 kHz
FSA	0.75	2.2	2.2	1.87	1.54	1.32	1.1	0.99	0.88
	1.1	3.1	3.1	2.64	2.17	1.86	1.55	1.4	1.24
	1.5	4.1	4.1	3.49	2.87	2.46	2.05	1.85	1.64
	2.2	5.6	5.6	4.76	3.92	3.36	2.8	2.52	2.24
	3	7.3	7.3	6.21	5.11	4.38	3.65	3.29	2.92
FSB	4	8.8	8.8	7.48	6.16	5.28	4.4	3.96	3.52
	5.5	12.5	12.5	14.03	8.75	7.5	6.25	5.63	5
	7.5	16.5	16.5	15.3	11.48	9.9	8.25	7.43	6.6
FSC	11	25	25	21.25	17.5	15	12.5	11.25	10
	15	31	31	26.35	21.7	18.6	15.5	13.95	12.4
FSD	18.5	37	37	31.4	25.9	22.2	18.5	16.6	14.8
	22	43	43	36.5	30.1	25.8	21.5	19.3	17.2
	30	58	58	49.3	40.6	34.8	29	26.1	23.2
	37	68	68	57.8	47.6	40.8	34	30.6	27.2
	45	82.5	82.5	70.1	57.7	49.4	41.2	37.1	33
FSE	55	103	103	87.5	72.1	61.8	51.5	46.3	41.2
FSF	75	136	136	115.6	95.2	81.6	68	61.2	54.4
	90	164	164	139.4	114.8	98.4	82	73.8	65.6
	110	201	141	101	80.4	–	–	–	–
	132	237	166	119	94.8	–	–	–	–
FSG	160	289	194	139	111	–	–	–	–
	200	364	244	174	139	–	–	–	–
	250	436	305	218	174	–	–	–	–
FSH ²⁾	315	590	472	–	–	–	–	–	–
	355	645	516	–	–	–	–	–	–
	400	725	580	–	–	–	–	–	–
FSJ ²⁾	450	820	656	–	–	–	–	–	–
	500	895	716	–	–	–	–	–	–
	560	1015	812	–	–	–	–	–	–

The rated output currents indicated in **bold** are valid for the standard pulse frequency.

¹⁾ Rated power based on the rated output current I_{rated} . The rated output current I_{rated} is based on the duty cycle for low overload (LO).

²⁾ With the factory setting these converters start at a pulse frequency of 4 kHz and automatically reduce the pulse frequency under load to the corresponding required frequencies. The pulse frequency increases automatically up to 4 kHz with decreasing load. The rated current values refer to a pulse frequency of 2 kHz and are reached at any time by automatic adaptation of the output pulse frequency.

SINAMICS G120XA infrastructure converters for standard pumps/fans

0.75 kW to 560 kW

SINAMICS G120XA infrastructure converters for standard pumps/fans

Characteristic curves (continued)

Ambient temperature

Frame sizes FSA to FSG:

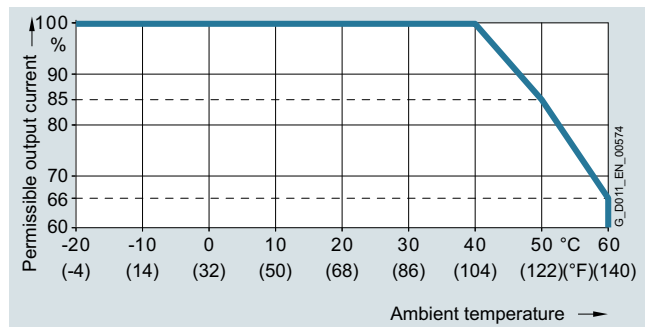

Permissible output current as a function of the ambient temperature for SINAMICS G120XA, frame sizes FSA to FSG, for low overload (LO)

Frame sizes FSH and FSJ:

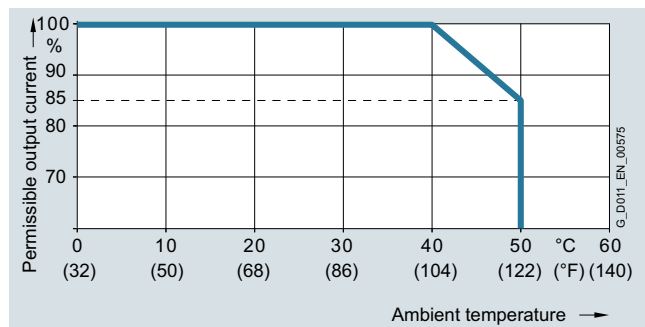

Permissible output current as a function of the ambient temperature for SINAMICS G120XA, frame sizes FSH and FSJ, for low overload (LO)

The operating temperature ranges of the Operator Panels should be taken into account.

Installation altitude

Frame sizes FSA to FSJ:

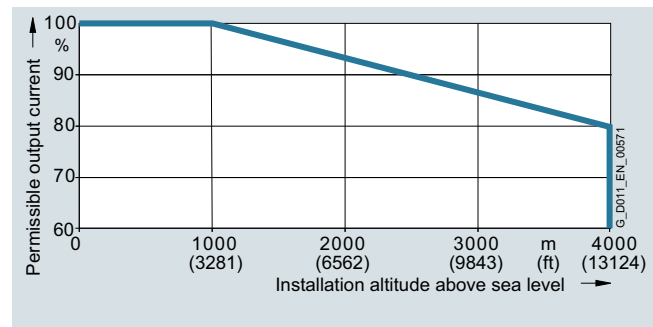

Permissible output current as a function of the installation altitude for SINAMICS G120XA for low overload (LO)

The connected motors, power elements and components must be considered separately.

Permissible line supplies as a function of the installation altitude

- Installation altitude up to 2000 m (6562 ft) above sea level
 - Connection to every supply system permitted for the converter
- Installation altitudes between 2000 m (6562 ft) and 4000 m (13124 ft) above sea level
 - Connection only to a TN system with grounded neutral point
 - TN systems with grounded line conductor are not permitted
 - The TN line system with grounded neutral point can also be supplied using an isolation transformer
 - The phase-to-phase voltage does not have to be reduced

System operating voltage

Frame sizes FSA to FSG:

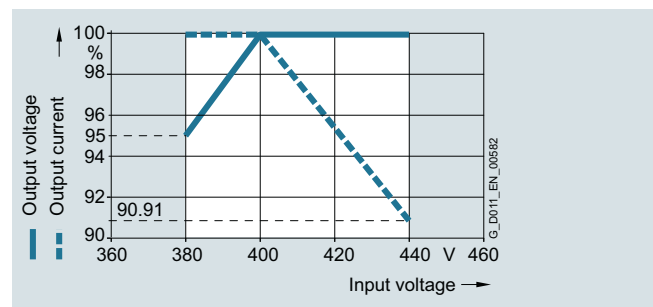

Permissible output current and output voltage as a function of the input voltage for SINAMICS G120XA, frame sizes FSA to FSG, for low overload (LO)

Frame sizes FSH and FSJ:

Frame size	Rated power ¹⁾ kW	Rated output current A	Base-load current ²⁾ A	Rated output current in % at a line voltage of			
				380 V	400 V	415 V	440 V
FSH	315	605	590	100 %	96.3 %	93.5 %	88.8 %
	355	670	645	100 %	96.1 %	93.2 %	88.3 %
	400	750	725	100 %	96.3 %	93.6 %	89 %
FSJ	450	840	820	100 %	95.6 %	92.3 %	86.8 %
	500	925	895	100 %	95.3 %	91.7 %	85.8 %
	560	1035	1015	100 %	95.8 %	92.7 %	87.5 %

¹⁾ Rated power based on the rated output current I_{rated} . The rated output current I_{rated} is based on the duty cycle for low overload (LO).

²⁾ The base-load current is based on the duty cycle for low overload (LO).

SINAMICS G120XA infrastructure converters for standard pumps/fans

0.75 kW to 560 kW

SINAMICS G120XA infrastructure converters for standard pumps/fans

Dimensional drawings

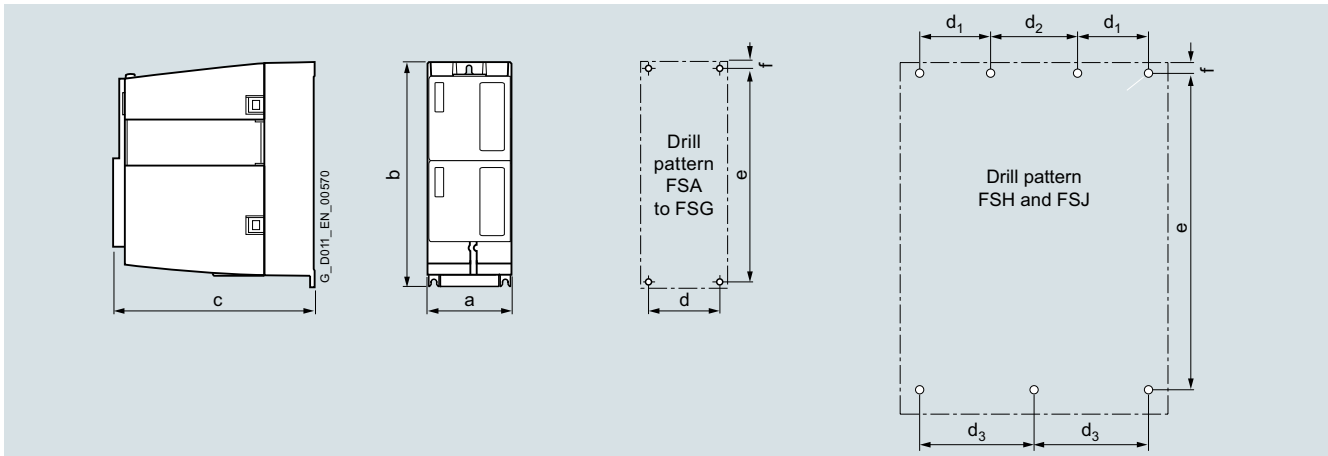

Principle dimension drawing and drill pattern for SINAMICS G120XA

Frame size	Dimensions in mm (inches)			Drilling dimensions in mm (inches)						Cooling clearance ²⁾ in mm (inches)			Mounting With screws (plus washers and nuts)
	a (width)	b (height)	c (depth) ¹⁾	d	d ₁	d ₂	d ₃	e	f	top	bottom	front	
FSA	73 (2.87)	232 (9.13)	209 (8.23)	55 (2.17)	–	–	–	221.5 (8.72)	5.5 (0.22)	80 (3.15)	100 (3.94)	0 (0)	4 × M4
FSB	100 (3.94)	275 (10.83)	209 (8.23)	80 (3.15)	–	–	–	265 (10.43)	7 (0.28)	80 (3.15)	100 (3.94)	0 (0)	4 × M4
FSC	140 (5.51)	295 (11.61)	209 (8.23)	118 (4.65)	–	–	–	283 (11.14)	7 (0.28)	80 (3.15)	100 (3.94)	0 (0)	4 × M5
FSD	200 (7.87)	472 (18.58)	239 (9.41)	170 (6.69)	–	–	–	430 (16.93)	15 (0.59)	300 (11.81)	350 (13.78)	0 (0)	4 × M5
FSE	275 (10.83)	551 (21.69)	239 (9.41)	230 (9.06)	–	–	–	509 (20.04)	11 (0.43)	300 (11.81)	350 (13.78)	0 (0)	4 × M6
FSF	305 (12.01)	709 (27.91)	360 (14.17)	270 (10.63)	–	–	–	680 (26.77)	16.6 (0.65)	300 (11.81)	350 (13.78)	0 (0)	4 × M8
FSG	305 (12.01)	999 (39.33)	360 (14.17)	265 (10.43)	–	–	–	970.5 (38.21)	18.5 (0.73)	300 (11.81)	350 (13.78)	0 (0)	4 × M10
FSH	548 (21.57)	1487 (58.54)	410 (16.14)	–	150 (5.91)	150 (5.91)	225 (8.86)	1444 (56.85)	21 (0.83)	200 (7.87)	200 (7.87)	100 (3.94)	7 × M8
FSJ	801 (31.54)	1438 (56.61)	410 (16.14)	–	200 (7.87)	290 (11.42)	345 (13.58)	1399 (55.08)	21 (0.83)	200 (7.87)	200 (7.87)	100 (3.94)	7 × M8

More information

Compact Installation Instructions are supplied in hard copy form in English and Chinese with every SINAMICS G120XA. Further documentation, such as the operating instructions, is available free on the Internet at:

www.siemens.com/sinamics-g120xa/documentation

Detailed information on the SINAMICS G120XA infrastructure converters for standard pumps/fans, including the latest technical documentation (brochures, tutorials, dimensional drawings, certificates and operating instructions), is available on the Internet at:

www.siemens.com.cn/sinamics-g120xa

and is also available via the Drive Technology Configurator (DT Configurator) on the Internet.

The DT Configurator can be found in the Siemens Industry Mall at the following address:

www.siemens.com.cn/dt-configurator

¹⁾ Increased depth for frame sizes FSA to FSG:

- When the operator panel is plugged on, the depth increases by 9 mm (0.35 in)
- When the SINAMICS G120 Smart Access is plugged on, the depth increases by 7 mm (0.28 in)

²⁾ The converters with frame sizes FSA to FSG can be mounted side by side. A side clearance of 1 mm (0.04 in) is recommended for tolerance-related reasons. For frame sizes FSH and FSJ, a side clearance of 30 mm (1.18 in) between the converters is required.

SINAMICS G120XA infrastructure converters for standard pumps/fans

0.75 kW to 560 kW

Supplementary system components > Operator panels

Overview

Operator panel	IOP-2 and IOP-2 Handheld Intelligent Operator Panel	BOP-2 Basic Operator Panel
Description		
	<p>Thanks to the high-contrast color display, menu-based operation and the wizards, commissioning of the standard drives is easy. Application wizards guide the user through the commissioning of important applications such as pumps, fans, compressors, or conveyor systems.</p>	<p>Commissioning of standard drives is easy with the menu-prompted dialog on a 2-line display. Simultaneous display of the parameter and parameter value, as well as parameter filtering, means that basic commissioning of a drive can be performed easily and, in most cases, without a printed parameter list.</p>
Possible applications	<ul style="list-style-type: none"> • Can be mounted directly on the converter • Can be mounted in a control cabinet door using a door mounting kit (achievable degree of protection is IP55/UL Type 12 enclosure) • Available as handheld version • The following languages are integrated in the IOP-2: English, German, French, Italian, Spanish, Portuguese, Dutch, Swedish, Finnish, Russian, Czech, Polish, Turkish, Chinese Simplified 	<ul style="list-style-type: none"> • Can be mounted directly on the converter • Can be mounted in the control cabinet door using a door mounting kit (achievable degree of protection is IP55/UL Type 12)
Quick commissioning without expert knowledge	<ul style="list-style-type: none"> • Standard commissioning using the clone function • For quicker access, the parameter block names can be directly entered respectively changed on the IOP-2 using the virtual keyboard. • User-defined parameter list with a reduced number of self-selected parameters • Simple commissioning of standard applications using application-specific wizards; it is not necessary to know the parameter structure • Simple local commissioning using the handheld version • Commissioning is possible largely without documentation 	<ul style="list-style-type: none"> • Standard commissioning using the clone function
High degree of operator friendliness and intuitive operation	<ul style="list-style-type: none"> • Intuitive navigation by operating with a sensor control field • Graphic color display to show status values such as pressure or flow rate in the form of scalar values, bar-type diagrams, or trend displays • Status display with freely selectable units to specify physical values • Direct manual operation of the drive – you can simply toggle between the automatic and manual modes • Simple cloning of specific settings of the IOP-2 user interface. 	<ul style="list-style-type: none"> • 2-line display for showing up to 2 process values with text • Status display of predefined units • Direct manual operation of the drive – you can simply toggle between the automatic and manual modes
Minimization of maintenance times	<ul style="list-style-type: none"> • Diagnostics using plain text display, can be used locally on-site without documentation • The support function is used to determine the drive data for the Power Module, Control Unit and IOP-2 and makes this available as a two-dimensional code (data matrix/QR code) • Easily upgradable to new functional status via USB interface 	<ul style="list-style-type: none"> • Diagnostics with menu prompting with 7-segment display

Overview**IOP-2 Intelligent Operator Panel**

IOP-2 Intelligent Operator Panel

The Intelligent Operator Panel IOP-2 is a very user-friendly and powerful operator panel for the SINAMICS G120, SINAMICS G120C, SINAMICS G120X, SINAMICS G120XA, SINAMICS G110D, SINAMICS G120D, SINAMICS G110M and SIMATIC ET 200pro FC-2.

The IOP-2 supports both newcomers and drive experts. Thanks to the membrane keyboard with a central sensor control field, high-contrast color displays, menu-based operation and application wizards, it is easy to commission drives. A drive can be essentially commissioned without having to use a printed parameter list – as the parameters are displayed in plain text, and explanatory help texts and the parameter filtering function are provided.

Application wizards interactively guide you when commissioning important applications such as conveyor technology, pumps, fans and compressors. There is a basic commissioning wizard for general commissioning.

Up to two process values can be graphically visualized and up to four process values can be numerically visualized on the status screen/display. Process values can also be displayed in technological units.

The IOP-2 supports standard commissioning of identical drives. For this purpose, a parameter list can be copied from a converter into the IOP-2 and downloaded into other drive units of the same type as required.

The IOP-2 can be installed in control cabinet doors using the optionally available door mounting kit.

Updating the IOP-2

The IOP-2 can be updated and expanded using the integrated USB interface.

Data to support future drive systems can be transferred from the PC to the IOP-2. Further, the USB interface allows user languages and wizards that will become available in the future to be subsequently downloaded and the firmware to be updated for the IOP-2¹⁾.

The IOP-2 is supplied with power via the USB interface during an update.

IOP-2 Handheld

IOP-2 Handheld

A handheld version of the IOP-2 can be ordered for mobile use. In addition to the IOP-2, it includes a housing with rechargeable batteries, a charging unit, an RS232 connecting cable, and a USB cable. The charging unit is supplied with connector adapters for Europe, the US and UK. When the batteries are fully charged, the operating time is up to 10 hours.

To connect the IOP-2 Handheld to SINAMICS G110D, SINAMICS G120D, SINAMICS G110M and SIMATIC ET 200pro FC-2, the RS232 connecting cable with optical interface is required in addition.

¹⁾ Information on updates for the IOP-2 is available at <https://support.industry.siemens.com/cs/document/67273266>

SINAMICS G120XA infrastructure converters for standard pumps/fans

0.75 kW to 560 kW

Supplementary system components > IOP-2 Intelligent Operator Panel

Selection and ordering data

Description	Article No.
<p>IOP-2 Intelligent Operator Panel</p> <p>For use with SINAMICS G120 SINAMICS G120C SINAMICS G120X SINAMICS G120XA SINAMICS G110D SINAMICS G120D SINAMICS G110M SIMATIC ET 200pro FC-2</p> <p>Operating languages: English, German, French, Italian, Spanish, Portuguese, Dutch, Swedish, Finnish, Russian, Czech, Polish, Turkish, Chinese Simplified</p>	6SL3255-0AA00-4JA2
<p>IOP-2 Handheld</p> <p>For use with SINAMICS G120 SINAMICS G120C SINAMICS G120X SINAMICS G120XA SINAMICS G110D SINAMICS G120D SINAMICS G110M SIMATIC ET 200pro FC-2</p> <p>Included in the scope of delivery:</p> <ul style="list-style-type: none"> • IOP-2 • Handheld housing • Rechargeable batteries (4 × AA) • Charging unit (international) • RS232 connecting cable¹⁾ 3 m (9.84 ft) long, can be used in combination with SINAMICS G120 SINAMICS G120C SINAMICS G120X SINAMICS G120XA • USB cable 1 m (3.28 ft) long 	6SL3255-0AA00-4HA1
Accessories	
<p>Door mounting kit</p> <p>For mounting an operator panel in control cabinet doors with sheet steel thicknesses of 1 ... 3 mm (0.04 in ... 0.12 in) Degree of protection IP55 Included in the scope of delivery:</p> <ul style="list-style-type: none"> • Seal • Mounting material • Connecting cable 5 m (16.4 ft) long, also supplies voltage to the IOP-2 directly via the converter 	6SL3256-0AP00-0JA0
<p>RS232 connecting cable</p> <p>2.5 m (8.20 ft) long, with optical interface for connecting the IOP-2 Handheld to SINAMICS G110D SINAMICS G120D SINAMICS G110M SIMATIC ET 200pro FC-2</p>	3RK1922-2BP00

Benefits

- New device design
 - Intuitive user interface – membrane keyboard with central sensor control field
 - High-contrast color display with a range of display options
 - IOP-2 device design open for future functional expansions (e.g. device functions, wizards, languages)
 - Easily upgradable to new functional status via USB interface
- Commissioning
 - Simple commissioning via wizards
 - The "Fieldbus Interface Settings" wizard is used for easy configuration of the Ethernet interface
 - Fast standard commissioning of converters thanks to cloning function
 - For quicker access, the parameter block names can be directly entered respectively changed on the IOP-2 using the virtual keyboard.
 - Simple local commissioning on-site using the handheld version
- Operator control and monitoring
 - Simple, individual local drive control (start/stop, setpoint value specification, change in direction of rotation)
 - Application-specific scenarios such as operator concepts with additional external operating elements can be implemented easily
 - Simple cloning of specific settings of the IOP-2 user interface, such as status screen, language settings, lighting duration, date/time settings, parameter backup mode and "My Parameters" – settings made once can such be easily transferred to many further IOP-2 Intelligent Operator Panels
- Diagnostics
 - Rapid diagnostics thanks to on-site plain text display
 - Integrated plain text help function for local display and resolution of fault messages
- Support function
 - Used to determine the drive data for the Power Module, Control Unit and IOP-2 (article number, serial number, firmware version, error statuses) and makes this available as a two-dimensional code (data matrix/QR code)
 - Allows easy contact with Customer Support via a data matrix/QR code generated on the IOP-2
 - Quick access via mobile devices (e.g. smartphones, tablets) to product information, documentation, FAQs, contact persons via a two-dimensional code generated on the IOP-2 (data matrix/QR code)
 - Scanning and evaluating of the two-dimensional data matrix code using the Industry Online Support app (<https://support.industry.siemens.com/cs/ww/en/sc/2067>), see also: <https://support.industry.siemens.com/cs/document/109748340>

¹⁾ For use in conjunction with SINAMICS G110D, SINAMICS G120D, SINAMICS G110M and SIMATIC ET 200pro FC-2, the RS232 connecting cable with optical interface is required (Article No.: **3RK1922-2BP00**). The cable must be ordered separately.

SINAMICS G120XA infrastructure converters for standard pumps/fans

0.75 kW to 560 kW

Supplementary system components > IOP-2 Intelligent Operator Panel

Integration

Using the IOP-2 with the converters

	<ul style="list-style-type: none"> • SINAMICS G120 with CU230P-2, CU240E-2 or CU250S-2 • SINAMICS G120C • SINAMICS G120X and SINAMICS G120XA 	<ul style="list-style-type: none"> • SINAMICS G110D • SINAMICS G120D • SINAMICS G110M • SIMATIC ET 200pro FC-2
Plugging the IOP-2 onto the converter (Voltage supply via converter)	✓	–
Door mounting of the IOP-2 with the door mounting kit (Voltage supply via converter. For this purpose, the IOP-2 must be connected up by means of the connecting cable supplied with the door mounting kit.)	✓	–
Mobile use of the IOP-2 Handheld (supplied from rechargeable batteries)	✓	✓ (RS232 connecting cable with optical interface required, article number 3RK1922-2BP00)

Door mounting

Using the optionally available door mounting kit, an operator panel can be simply mounted in a control cabinet door with just a few manual operations. In the case of door mounting, the IOP-2 Operator Panel achieves degree of protection IP55/UL Type 12 enclosure.

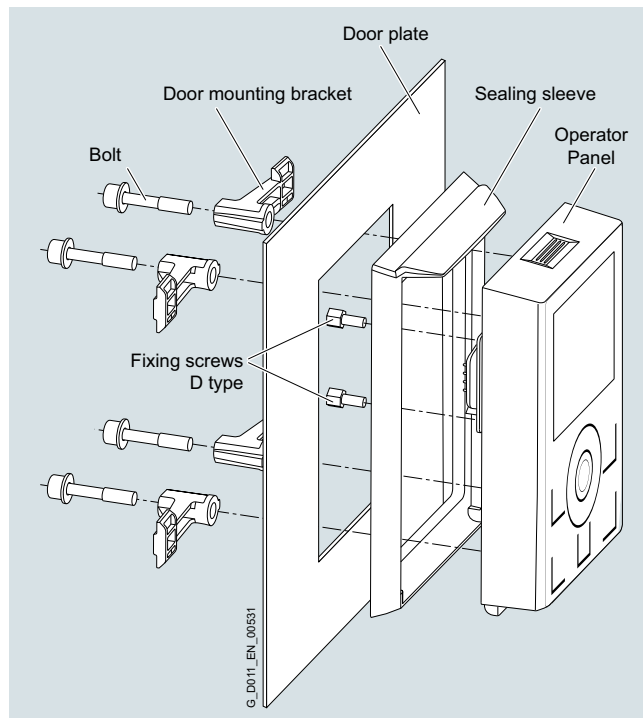

Door mounting kit with plugged-on IOP-2

Technical specifications

	IOP-2 6SL3255-0AA00-4JA2	IOP-2 Handheld 6SL3255-0AA00-4HA1
Display	High-contrast color display, a variety of display options	
• Resolution	320 × 240 pixels	
Operator panel	Membrane keyboard with central sensor control field	
Operating languages	English, German, French, Italian, Spanish, Portuguese, Dutch, Swedish, Finnish, Russian, Czech, Polish, Turkish, Chinese Simplified	
Ambient temperature		
• During transport and storage	-40 ... +70 °C (-40 ... +158 °F)	-20 ... +55 °C (-4 ... +131 °F)
• During operation	For direct mounting on the converter: 0 ... 50 °C (32 ... 122 °F) For installation with door mounting kit: 0 ... 55 °C (32 ... 131 °F)	0 ... 40 °C (32 ... 104 °F)
Humidity	Relative humidity < 95 %, non-condensing	
Degree of protection	For direct mounting on the converter: IP20 For installation with door mounting kit: IP55, UL Type 12 enclosure	IP20
Dimensions (H × W × D)	106.86 × 70 × 19.65 mm (4.21 × 2.76 × 0.77 in)	195.04 × 70 × 37.58 mm (7.68 × 2.76 × 1.48 in)
Weight, approx.	0.134 kg (0.3 lb)	0.724 kg (1.6 lb)
Compliance with standards	CE, RCM, cULus, EAC, KC-REM-S49-SINAMICS	

SINAMICS G120XA infrastructure converters for standard pumps/fans

0.75 kW to 560 kW

Supplementary system components > BOP-2 Basic Operator Panel

Overview



BOP-2 Basic Operator Panel

The Basic Operator Panel BOP-2 can be used to commission drives, monitor drives in operation and input individual parameter settings.

Commissioning of standard drives is easy with the menu-prompted dialog on a 2-line display. Simultaneous display of the parameter and parameter value, as well as parameter filtering, means that basic commissioning of a drive can be performed easily and, in most cases, without a printed parameter list.

The drives are easily controlled manually using directly assigned navigation buttons. The BOP-2 has a dedicated switchover button to switch from automatic to manual mode.

Diagnostics can easily be performed on the connected converter by following the menus.

Up to two process values can be numerically visualized simultaneously.

BOP-2 supports standard commissioning of identical drives. For this purpose, a parameter list can be copied from a converter into the BOP-2 and when required, downloaded into other drive units of the same type.

The operating temperature of the BOP-2 is 0 °C ... 50 °C (32 °F ... 122 °F).

Selection and ordering data

Description	Article No.
BOP-2 Basic Operator Panel	6SL3255-0AA00-4CA1
Accessories	
Door mounting kit For mounting an operator panel in control cabinet doors with sheet steel thicknesses of 1 ... 3 mm (0.04 ... 0.12 in) Degree of protection IP55	6SL3256-0AP00-0JA0
Included in the scope of delivery:	
<ul style="list-style-type: none"> • Seal • Mounting material • Connecting cable (5 m/16.4 ft long, also supplies voltage to the operator panel directly via the converter) 	

Benefits

- Shorten commissioning times – Easy commissioning of standard drives using basic commissioning wizards (setup)
- Minimize standstill times – Fast detection and rectification of faults (Diagnostics)
- Greater transparency in the process – The status display of the BOP-2 makes process variable monitoring easy (Monitoring)
- Direct mounting on the converter
- User-friendly user interface:
 - Easy navigation using clear menu structure and clearly assigned control keys
 - Two-line display

SINAMICS G120XA infrastructure converters for standard pumps/fans

0.75 kW to 560 kW

Supplementary system components > Memory cards

Overview



SINAMICS SD memory card

The parameter settings for a converter can be stored on the SINAMICS SD memory card. When service is required, e.g. after the converter has been replaced and the data have been downloaded from the memory card, the drive system is immediately ready for use again.

- Parameter settings can be written from the memory card to the converter or saved from the converter to the memory card.
- Up to 100 parameter sets can be stored.
- The memory card supports standard commissioning without the use of an operator panel such as the IOP-2 or BOP-2.
- If firmware is stored on the memory card, the firmware can be upgraded/downgraded during power-up.

Note:

The memory card is not required for operation and does not have to remain inserted.

Selection and ordering data

Description	Article No.
SINAMICS SD card 512 MB, empty	6SL3054-4AG00-2AA0

SINAMICS G120XA infrastructure converters for standard pumps/fans

0.75 kW to 560 kW

Supplementary system components > SINAMICS G120 Smart Access

Overview



SINAMICS G120 Smart Access

It is also easy and convenient to commission and operate the SINAMICS G120, SINAMICS G120C, SINAMICS G120X and SINAMICS G120XA converters of firmware V4.7 SP6 and higher using the web server module SINAMICS G120 Smart Access and a connected smartphone, tablet or laptop.

Benefits

- Wireless commissioning, operation and diagnostics via mobile device or laptop thanks to the optional SINAMICS G120 Smart Access
- Easy access to the converter in difficult-to-access areas
- Intuitive user interface and commissioning wizard
- Free choice of terminal devices as the web server works with all common web browsers, such as iOS, Android, Windows, Linux and Mac OS

Function

- Commissioning using commissioning wizard
- Setting and saving parameters
- Testing motor in JOG mode
- Monitoring of converter data
- Quick diagnostics
- Saving the settings and restoring to factory settings

Selection and ordering data

Description	Article No.
SINAMICS G120 Smart Access For wireless commissioning, operation and diagnostics of the following converters using a smartphone, tablet or laptop <ul style="list-style-type: none"> • SINAMICS G120C • SINAMICS G120 together with the CU230P-2 and CU240E-2 Control Units (without fail-safe versions) • SINAMICS G120X and SINAMICS G120XA 	6SL3255-0AA00-5AA0

Technical specifications

SINAMICS G120 Smart Access	
6SL3255-0AA00-5AA0	
Operating system	iOS, Android, Windows, Linux, Mac OS
Languages	Support of six languages: English, French, German, Italian, Spanish, Chinese
Ambient temperature	
• During storage and transport	-40 ... +70 °C (-40 ... +158 °F)
• During operation	0 ... 50 °C (32 ... 122 °F) if the Smart Access is plugged directly into the converter
Humidity	< 95 %, non-condensing
Degree of protection	Depending on the degree of protection of the converter, max. IP55/UL Type 12 enclosure
Dimensions	
• Width	70 mm (2.76 in)
• Height	108.9 mm (4.29 in)
• Depth	17.3 mm (0.68 in)
Weight, approx.	0.08 kg (0.18 lb)
Compliance with standards	CE, FCC, SRRG, WPC, ANATEL, BTK

Integration



SINAMICS G120XA frame size FSD with plugged-on SINAMICS G120 Smart Access

The optional SINAMICS G120 Smart Access is simply plugged onto the converter and is available for the following converters of firmware V4.7 SP6 and higher.

- SINAMICS G120C
- SINAMICS G120 together with the CU230P-2 and CU240E-2 Control Units (without fail-safe versions)
- SINAMICS G120X and SINAMICS G120XA

SINAMICS G120XA infrastructure converters for standard pumps/fans

0.75 kW to 560 kW

Supplementary system components > Shield connection kits for Power Module**Overview**

A shield connection kit is supplied with the SINAMICS G120XA converters, frame size FSA. It is advisable to install the supplied shield connection kit for EMC-compliant configuration of the converter.

The shield connection kits for the Power Module are not included in the scope of delivery for the SINAMICS G120XA converters, frame sizes FSB to FSG, but they can be ordered as an option.

Please observe the notes included in the operating instructions for the SINAMICS G120XA converters, frame sizes FSH and FSJ.

www.siemens.com/sinamics-g120xa/documentation

Selection and ordering data

Description	Article No.
Shield connection kits for Power Module for SINAMICS G120XA	
• Frame size FSA	Included in the scope of delivery of the converters, can be ordered as spare part
• Frame size FSB (available soon)	6SL3262-1AB01-0DA0
• Frame size FSC (available soon)	6SL3262-1AC01-0DA0
• Frame size FSD	6SL3262-1AD01-0DA0
• Frame size FSE	6SL3262-1AE01-0DA0
• Frame size FSF	6SL3262-1AF01-0DA0
• Frame size FSG	6SL3262-1AG01-0DA0

2

SINAMICS G120XA infrastructure converters for standard pumps/fans

0.75 kW to 560 kW

Spare parts > FPI board for frame sizes FSH and FSJ

Overview

The FPI board (freely-programmable interface board) is available as a spare part for the SINAMICS G120X and SINAMICS G120XA converters, frame sizes FSH and FSJ. This is an interface board between Control Unit and Power Module with additional customer terminals (X9, X41).

Selection and ordering data

Description	Article No.
FPI board (available soon) for SINAMICS G120X and SINAMICS G120XA frame sizes FSH and FSJ	available soon

Spare parts > PSB board for frame sizes FSH and FSJ

Overview

The PSB board (power supply board) is available as a spare part for the SINAMICS G120X and SINAMICS G120XA converters, frame sizes FSH and FSJ. This is an internal power supply with ± 24 V for the electronics and 56 V for a power unit fan.

Selection and ordering data

Description	Article No.
PSB board (available soon) for SINAMICS G120X and SINAMICS G120XA frame sizes FSH and FSJ	available soon

Spare parts > Current transformers for frame sizes FSH and FSJ

Overview

Current transformers are available as spare parts for the SINAMICS G120X and SINAMICS G120XA converters, frame sizes FSH and FSJ. These are 2000 A or 1000 A current transformers for measuring the motor current at the device output. The current transformers are used for motor control and converter protection.

Selection and ordering data

Description	Article No.
Current transformers (available soon) for SINAMICS G120X and SINAMICS G120XA	
• 2000 A for frame sizes FSH and FSJ	6SL3200-0SE01-0AA0
• 1000 A for frame size FSJ	6SL3200-0SE02-0AA0

Spare parts > Spare parts kit for Control Unit

Overview

The spare parts kit contains small parts for the SINAMICS G120X and SINAMICS G120XA Control Unit:

Included in the scope of delivery:

- 1x STO connecting plug for frame sizes FSA to FSC
- 3x replacement doors for the Control Unit
- 4x I/O terminals
- 1x screw for RS485 terminal
- 1x blanking cover
- Label set

Selection and ordering data

Description	Article No.
Spare parts kit for Control Unit (available soon) for SINAMICS G120X and SINAMICS G120XA	6SL3200-0SK10-0AA0

Spare parts > Shield connection kit for Control Unit

Overview

A shield connection kit for the Control Unit is supplied with the SINAMICS G120X and SINAMICS G120XA converters, frame sizes FSD to FSG. It is advisable to install the supplied shield connection kit for EMC-compliant configuration of the converter. This shield connection kit can be ordered as a spare part.

The shield connection kit offers optimum shield connection and strain relief for all signal and communication cables.

The kit contains the following:

- a matching shield connection plate
- all of the necessary connecting and retaining elements for mounting

Selection and ordering data

Description	Article No.
Shield connection kit for Control Unit (available soon) for SINAMICS G120X and SINAMICS G120XA frame sizes FSD to FSG	6SL3264-1EA00-0YA0

SINAMICS G120XA infrastructure converters for standard pumps/fans

0.75 kW to 560 kW

Spare parts > Shield connection kits for Power Module

Overview

A shield connection kit is supplied with the SINAMICS G120XA converters, frame size FSA. It is advisable to install the supplied shield connection kit for EMC-compliant configuration of the converter. This shield connection kit can also be ordered as spare part.

The shield connection kits for the Power Module are not included in the scope of delivery for the SINAMICS G120XA converters, frame sizes FSB to FSG, but they can be ordered as an option or as spare parts.

Please observe the notes included in the operating instructions for the SINAMICS G120XA converters, frame sizes FSH and FSJ.

www.siemens.com/sinamics-g120xa/documentation

Selection and ordering data

Description	Article No.
Shield connection kits for Power Module for SINAMICS G120XA	
• Frame size FSA (available soon)	6SL3262-1AA01-0DA0
• Frame size FSB (available soon)	6SL3262-1AB01-0DA0
• Frame size FSC (available soon)	6SL3262-1AC01-0DA0
• Frame size FSD	6SL3262-1AD01-0DA0
• Frame size FSE	6SL3262-1AE01-0DA0
• Frame size FSF	6SL3262-1AF01-0DA0
• Frame size FSG	6SL3262-1AG01-0DA0

2

Spare parts > Mounting set for frame sizes FSD to FSG

Overview

A **mounting set** can be ordered for SINAMICS G120 PM240-2 Power Modules, SINAMICS G120C, SINAMICS G120X and SINAMICS G120XA. It contains the following parts:

- 1 SUB-D connector with mounting material
- 1 motor connector and 1 power supply connector
- 2 serrated strips including mounting material for connecting the shield
- 3 sleeves for inserting in the cutouts for the signal cables of the cable bonding plate
- Ferrite cores
(only necessary for devices with integrated line filter class B)
- Screws for fixing the cable bonding plate and the cover

Selection and ordering data

Description	Article No.
Mounting set for SINAMICS G120 PM240-2 Power Modules, SINAMICS G120C, SINAMICS G120X and SINAMICS G120XA in frame sizes FSD to FSG	6SL3200-0SK08-0AA0

Spare parts > Terminal cover kits for frame sizes FSD to FSG

Overview

The terminal cover kit includes a replacement cover for the connecting terminals.

Terminal cover kits, which are suitable for the following converters in frame sizes FSD to FSG, are available:

- SINAMICS G120 PM240-2 Power Modules
- SINAMICS G120 PM250 Power Modules
- SINAMICS G120C
- SINAMICS G120X and SINAMICS G120XA

Selection and ordering data

Description	Article No.
Terminal cover kits for SINAMIC G120 PM240-2 Power Modules	
• for frame size FSD	6SL3200-0SM13-0AA0
• for frame size FSE	6SL3200-0SM14-0AA0
• for frame size FSF	6SL3200-0SM15-0AA0
• for frame size FSG	6SL3200-0SM16-0AA0
Terminal cover kits for SINAMICS G120 PM250 Power Modules	
• for frame sizes FSD and FSE	6SL3200-0SM11-0AA0
• for frame size FSF	6SL3200-0SM12-0AA0
Terminal cover kits for SINAMICS G120C	
• for frame size FSD	6SL3200-0SM13-0AA0
• for frame size FSE	6SL3200-0SM14-0AA0
• for frame size FSF	6SL3200-0SM15-0AA0
Terminal cover kits for SINAMICS G120X and SINAMICS G120XA	
• for frame size FSD	6SL3200-0SM13-0AA0
• for frame size FSE	6SL3200-0SM14-0AA0
• for frame size FSF	6SL3200-0SM15-0AA0
• for frame size FSG	6SL3200-0SM16-0AA0

SINAMICS G120XA infrastructure converters for standard pumps/fans

0.75 kW to 560 kW

Spare parts > Fan units

Overview

The fans of the SINAMICS G120XA converters are designed for extra long service life. For special requirements, replacement fans are available that can be exchanged quickly and easily.

Selection and ordering data

Description	Article No.
External fan units for SINAMICS G120XA	
• Frame size FSA (available soon)	6SL3200-0SF52-0AA0
• Frame size FSB (available soon)	6SL3200-0SF53-0AA0
• Frame size FSC (available soon)	6SL3200-0SF54-0AA0
• Frame size FSD	6SL3200-0SF15-0AA0
• Frame size FSE	6SL3200-0SF16-0AA0
• Frame size FSF	6SL3200-0SF17-0AA0
• Frame size FSG	6SL3200-0SF18-0AA0
• Frame size FSH (available soon)	6SL3200-0SF55-0AA0
• Frame size FSJ (available soon)	6SL3200-0SF56-0AA0
Internal fan unit (available soon) for SINAMICS G120XA	
• Frame sizes FSH and FSJ	6SL3200-0SF51-0AA0
Accessories	
SITOP power supply for the external fan unit for SINAMICS G120XA, frame sizes FSH and FSJ	6EP3446-8SB00-0AY0
Fuse for the external fan unit for SINAMICS G120XA, frame sizes FSH and FSJ	6SY7000-0AC46

Engineering tools



3/2 **Drive Technology Configurator**

3/3 **SinaSave energy efficiency tool**

3/4 **SINAMICS web server for
SINAMICS G120XA via
SINAMICS G120 Smart Access**

Security information

Siemens provides products and solutions with industrial security functions that support the secure operation of plants, systems, machines and networks.

In order to protect plants, systems, machines and networks against cyber threats, it is necessary to implement – and continuously maintain – a holistic, state-of-the-art industrial security concept. Siemens' products and solutions constitute one element of such a concept.

Customers are responsible for preventing unauthorized access to their plants, systems, machines and networks. Such systems, machines and components should only be connected to an enterprise network or the internet if and to the extent such a connection is necessary and only when appropriate security measures (e.g. firewalls and/or network segmentation) are in place.

For additional information on industrial security measures that may be implemented, please visit

<https://www.siemens.com/industrialsecurity>

Siemens' products and solutions undergo continuous development to make them more secure. Siemens strongly recommends that product updates are applied as soon as they are available and that the latest product versions are used. Use of product versions that are no longer supported, and failure to apply the latest updates may increase customer's exposure to cyber threats.

To stay informed about product updates, subscribe to the Siemens Industrial Security RSS Feed under

<https://www.siemens.com/industrialsecurity>

Engineering tools

Drive Technology Configurator

Overview

The Drive Technology Configurator (DT Configurator) helps you to configure the optimum drive technology products for your application – starting with gear units, motors, converters as well as the associated options and components and ending with controllers, software licenses and connection systems. Whether with little or detailed knowledge of products: preselected product groups, deliberate navigation through selection menus and direct product selection through entry of the article number support quick, efficient and convenient configuration.

In addition, comprehensive documentation comprising technical data sheets, 2D dimensional drawings/3D CAD models, operating instructions, certificates, etc. can be selected in the DT Configurator. Immediate ordering is possible by simply transferring a parts list to the shopping cart of the Industry Mall.

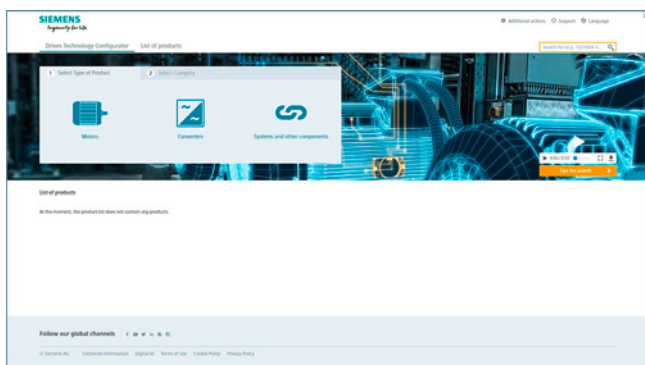

Drive Technology Configurator for efficient drive configuration with the following functions

- Quick and easy configuration of drive products and associated components – gear units, motors, converters, controllers, connection systems
- Configuration of drive systems for pumps, fans and compressor applications from 1 kW to 2.6 MW
- Retrievable documentation for configured products and components, such as
 - Data sheets in up to 9 languages in PDF or RTF format
 - 2D dimensional drawings/3D CAD models in various formats
 - Terminal box drawing and terminal connection diagram
 - Operating instructions
 - Certificates
 - Start-up calculation for SIMOTICS motors
 - EPLAN macros
- Support with retrofitting in conjunction with Spares On Web (www.siemens.com/sow)
- Ability to order products directly through the Siemens Industry Mall

Access to the Drive Technology Configurator

The Drive Technology Configurator can be called up without registration and without a login:
www.siemens.com.cn/dt-configurator

Selection and ordering data

Description	Article No.
Interactive Catalog CA 01 including Drive Technology Configurator	
• German (DVD-ROM – Edition Germany)	E86060-D4001-A500-D9
• German, English, French, Spanish (Download – without prices)	E86060-D4001-A510-D8-7500

More information

Online access to the Drive Technology Configurator

More information about the Drive Technology Configurator is available on the Internet at
www.siemens.com/dtconfigurator

Offline access to the Drive Technology Configurator in the Interactive Catalog CA 01

In addition, the Drive Technology Configurator is also included in the Interactive Catalog CA 01 – the offline version of the Siemens Industry Mall.

The Interactive Catalog CA 01 can be ordered from the relevant Siemens sales office or via the Internet:
www.siemens.com/automation/CA01

Overview

The SinaSave energy efficiency tool calculates potential energy savings and amortization times based on your individual conditions of use and therefore offers practical assistance in making decisions about investments in energy-efficient technologies.

From SinaSave Version 6.0 and higher, the drive systems to be compared and the relevant drive component parameters are displayed graphically. An additional expansion are the numerous comparison possibilities for different control types and comprehensive product combinations for drive solutions for pump and fan applications. In addition to SIMOTICS motors and SINAMICS drives, the product portfolio comprises SIRIUS switching devices, offering a comprehensive range of comparison possibilities – according to your individual requirements.



SinaSave offers numerous comparison scenarios:

- Comparison of drive systems for pump and fan applications in the output range from 0.55 kW (low voltage) to 5.5 MW (medium voltage) for
 - Reactor control (fixed speed; motor and switching device)
 - Bypass control (fixed speed; motor and switching device)
 - Speed control (variable speed; motor and frequency converter)
- Comparison and evaluation of standard motors (incl. ignition protection motors) in different energy efficiency classes

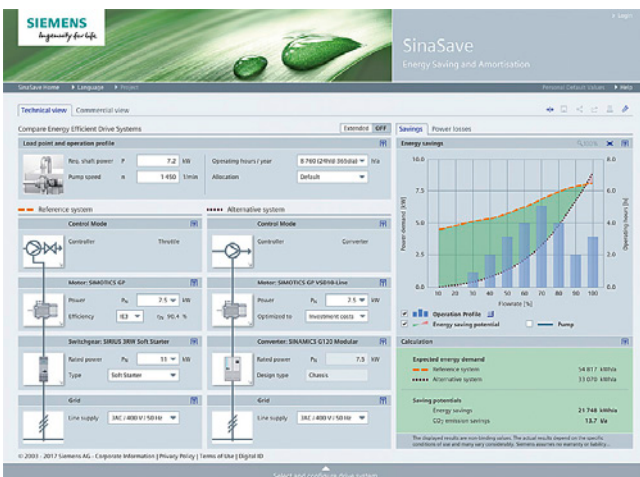

SinaSave supports the evaluation of the various comparisons of product and system by

- Displaying the potential savings for energy and energy costs, as well as CO₂ emissions
- Estimation of the amortization time
- Estimation of the individual total lifecycle costs
- Representation of the system power losses according to EN 50598-2 for full load and partial load
- Direct comparison of Siemens drives with the reference Power Drive System (PDS) described in EN 50598-2

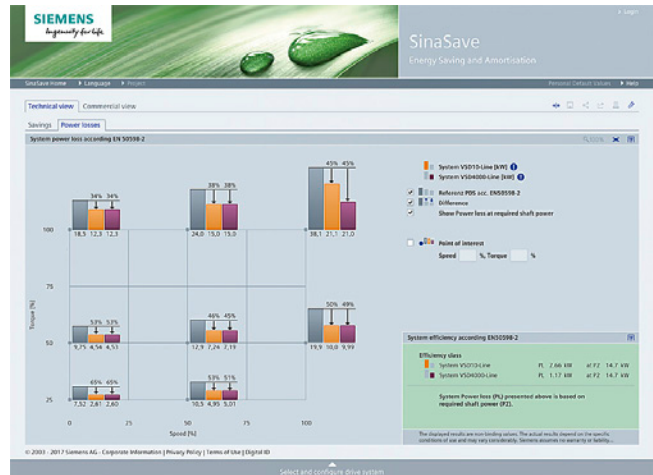

Access to the SinaSave energy efficiency tool

SinaSave can be accessed without the need for registration or logging in:
www.automation.siemens.com/sinasave

More information

For more information about the amortization calculator for energy-efficient drive systems, visit
www.siemens.com/sinasave

More information about services for energy saving is available on the Internet at
www.siemens.com/energysaving

Engineering tools

SINAMICS web server for SINAMICS G120XA via SINAMICS G120 Smart Access

Overview

Web server for efficient commissioning, diagnostics and maintenance

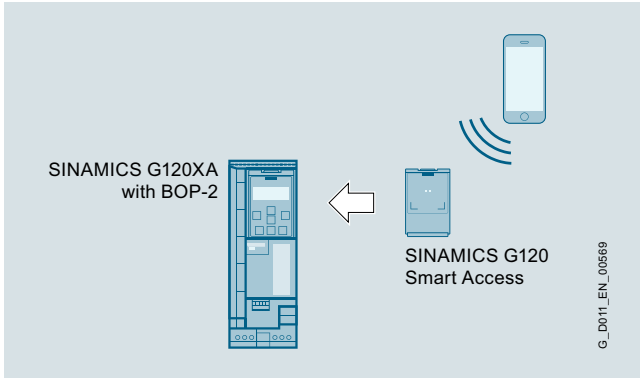

SINAMICS G120XA with BOP-2 and SINAMICS G120 Smart Access

Thanks to the optionally available SINAMICS G120 Smart Access, the SINAMICS G210XA drive system offers a web server for efficient commissioning, diagnostics and maintenance options. The web server provides access to a multi-faceted range of new options for parameter assignment and drive diagnostics for laptops, tablets and smartphones, including:

- Simple and fast commissioning
- Drive traversing via the control panel
- Downloading/uploading a configuration
- Providing a status overview of the drive
- Evaluating warnings and fault messages
- Monitoring and adapting parameter settings

Benefits

Simple and fast commissioning

- No installation of additional commissioning software
- Standard pages for limit values and settings
- Comprehensive fault diagnosis

Direct language selection

- English, German, French, Italian, Spanish, Chinese

Accessibility

- Free choice of terminal devices as the web server works with all common web browsers, such as iOS, Android, Windows, Linux and Mac OS

Diagnostic functions

- Quick overview of the current configuration and the state of the drive
- Understandable diagnostic information and messages, including the causes of issues and possible remedies, are displayed in plain text in multiple languages

Freely configurable parameter lists

- Monitoring parameters for diagnostic purposes, for example for operating personnel
- Adjustment of the parameter lists using filters, parameter groups and the configuration of personal lists

Access security

- Protection against unauthorized access to the drive information

Application

The web server is ideal for applications in which special commissioning software or version dependencies are not desired. Easy commissioning, diagnostics and maintenance are possible locally, provided appropriate security measures are applied.

Services and documentation



4/3	Partner · Industry Mall and Interactive Catalog CA 01
4/3	Information and Download Center
4/4	Industry Services
4/5	Industry Services – Portfolio overview
4/6	Online Support
4/7	Training
4/7	SITRAIN – Training for Industry
4/8	Training courses for SINAMICS low-voltage converters
4/9	SINAMICS G120XA training case
4/10	Control cabinets
4/12	Repair service contract RSC
4/14	Types of contract for production machines
4/15	Applications
4/16	Spare parts services
4/16	Spare parts services during the lifecycle
4/16	Delivery of spare parts
4/17	Delivery as exchange product
4/17	Repair
4/18	Product upgrade service
4/18	General overhaul
4/19	Function check
4/19	Return of diagnostic parts
4/20	Stock reduction in spare parts store
4/20	Extended spare part availability
4/21	Spares on Web
4/22	Product Partner – Drives Options
4/23	mySupport documentation
4/24	Documentation
4/24	General documentation
4/25	SINAMICS G120XA documentation

Services and documentation

Partner · Industry Mall and Interactive Catalog CA 01

Partner at Siemens

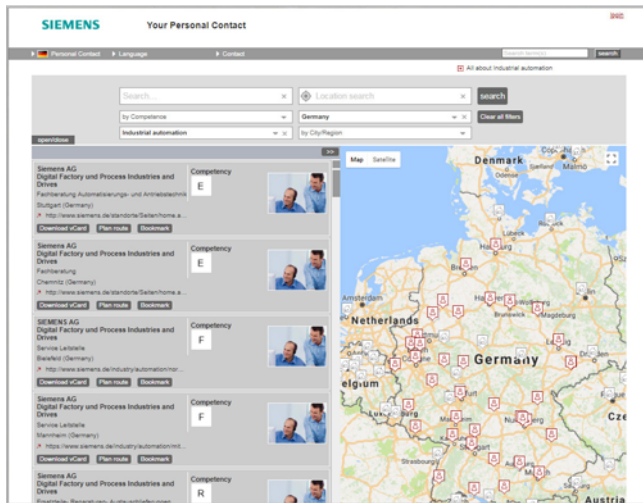

At your service locally, around the globe for consulting, sales, training, service, support, spare parts on the entire portfolio of Digital Factory and Process Industries and Drives.

Your partner can be found in our Personal Contacts Database at: www.siemens.com/automation-contact

You start by selecting

- the required competence,
 - products and branches,
 - a country and a city
- or by a
- location search or free text search.

Easy product selection and ordering in the Industry Mall and with the Interactive Catalog CA 01

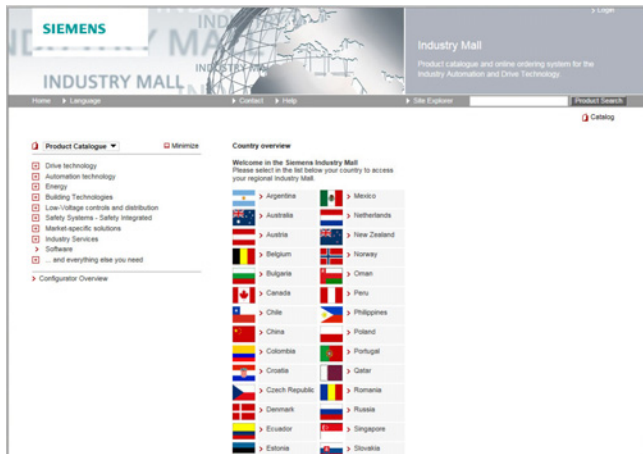

Industry Mall

The Industry Mall is a Siemens Internet ordering platform. Here you have a clear and informative online access to a huge range of products.

Powerful search functions make it easy to select the required products. Configurators enable you to configure complex product and system components quickly and easily. CAx data types are also provided here.

Data transfer allows the whole procedure, from selection through ordering to tracking and tracing, to be carried out online. Availability checks, customer-specific discounts and bid creation are also possible.

www.siemens.com/industrymall

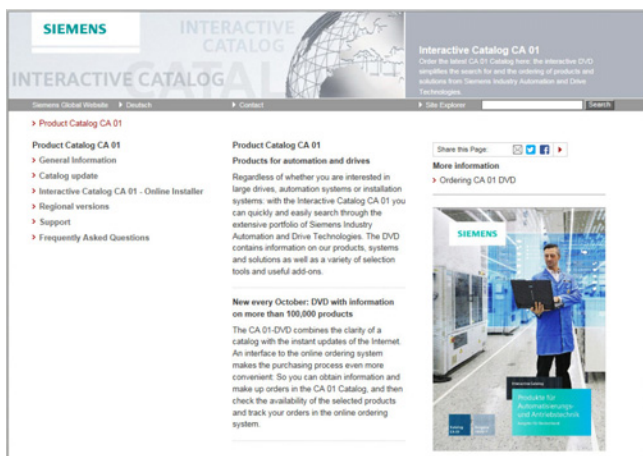

Interactive Catalog CA 01 - Products for Automation and Drives

The Interactive Catalog CA 01 combined with the Siemens Industry Mall unites the benefits of offline and online media in one application – the performance of an offline catalog with the availability of manifold and up-to-date information on the Internet.

Select products and assemble orders with the CA 01, determine the availability of the selected products and track & trace via the Industry Mall.

More information and download: www.siemens.com/automation/ca01

Downloading catalogs

The screenshot displays the Siemens Information and Download Center interface. At the top, there is a navigation bar with the Siemens logo and links for 'Home', 'Language', 'Contact', and 'Search'. Below this, the main content area is titled 'Information and Download Center'. It features a search bar with a 'Text Size' dropdown and a 'Share this Page' button. A navigation menu includes 'Catalogs (362)', 'Brochures (810)', 'Customer Magazines (8)', and 'Demo Software (15)'. A filter section allows users to search for 'Promotion packages (12)' with a filter input field set to '10' and a language dropdown set to 'English'. The main list shows two catalog entries: 'Catalog D 11 - 2015 (13 MB)' and 'Catalog D 12 - 2017 with dimension drawings'. Each entry includes an order number and a list of products. On the right side, there is a 'Products & Services' section with a list of categories such as 'Building Technologies (2)', 'Drive technology (294)', 'Energy (11)', 'Industrial automation (922)', 'Low-voltage controls and distribution (32)', 'Safety systems - Safety Integrated (31)', 'Services (8)', and 'Software (1)'. Below this is an 'All about Products & Services' section with links for 'Press releases', 'Catalog and ordering system online', 'Technical info', 'Support', and 'Service offer'.

In the Information and Download Center you can download catalogs and brochures in PDF format without having to register. The filter dialog makes it possible to carry out targeted searches.

www.siemens.com/industry/infocenter

Services and documentation

Industry Services

Overview

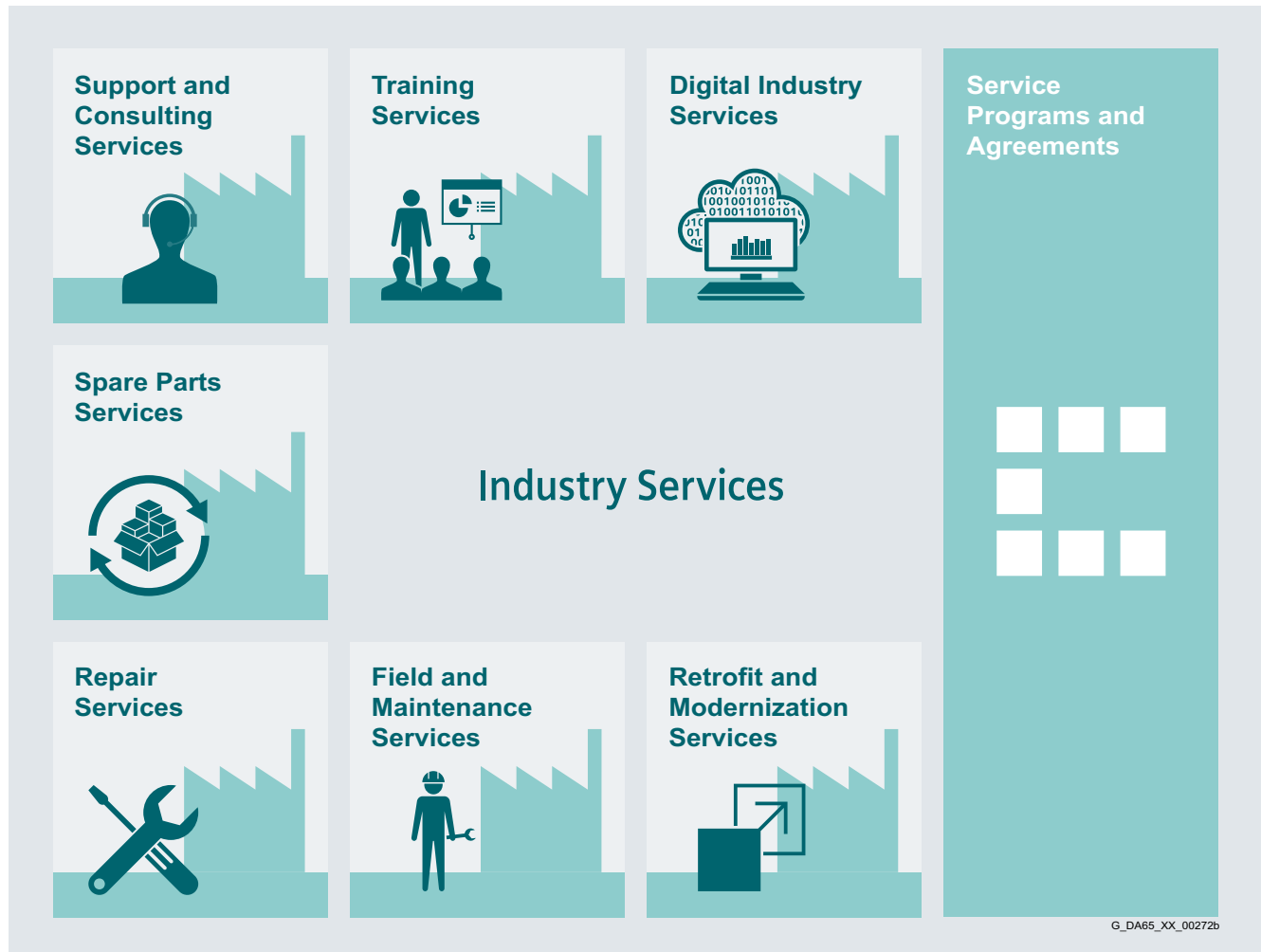

Keep your business running and shaping your digital future – with Industry Services

Optimizing the productivity of your equipment and operations can be a challenge, especially with constantly changing market conditions. Working with our service experts makes it easier. We understand your industry's unique processes and provide the services needed so that you can better achieve your business goals.

You can count on us to maximize your uptime and minimize your downtime, increasing your operations' productivity and reliability. When your operations have to be changed quickly to meet a new demand or business opportunity, our services give you the flexibility to adapt. Of course, we take care that your production is protected against cyber threats. We assist in keeping your operations as energy and resource efficient as possible and reducing your total cost of ownership. As a trendsetter, we ensure that you can capitalize on the opportunities of digitalization and by applying data analytics to enhance decision making: You can be sure that your plant reaches its full potential and retains this over the longer lifespan.

You can rely on our highly dedicated team of engineers, technicians and specialists to deliver the services you need – safely, professionally and in compliance with all regulations. We are there for you, where you need us, when you need us.

www.siemens.com/industrieservices

Overview



Digital Industry Services

Digital Industry Services

Digital Industry Services make your industrial processes transparent to gain improvements in productivity, asset availability, and energy efficiency.

Production data is generated, filtered and translated with intelligent analytics to enhance decision-making.

This is done whilst taking data security into consideration and with continuous protection against cyber-attack threats.

<https://www.siemens.com/global/en/home/products/services/industry/digital-services.html>

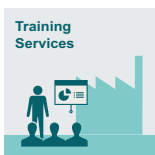

Training Services

Training Services

From the basics and advanced to specialist skills, SITRAIN courses provide expertise right from the manufacturer – and encompass the entire spectrum of Siemens products and systems for the industry.

Worldwide, SITRAIN courses are available wherever you need a training course in more than 170 locations in over 60 countries.

<https://support.industry.siemens.com/cs/ww/en/sc/2226>

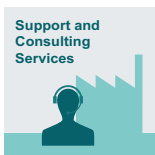

Support and Consulting Services

Support and Consulting Services

Industry Online Support site for comprehensive information, application examples, FAQs and support requests.

Technical and Engineering Support for advice and answers for all inquiries about functionality, handling, and fault clearance. The Service Card as prepaid support for value added services such as Priority Call Back or Extended Support offers the clear advantage of quick and easy purchasing.

Information & Consulting Services, e.g. SIMATIC System Audit; clarity about the state and service capability of your automation system or Lifecycle Information Services; transparency on the lifecycle of the products in your plants.

<https://support.industry.siemens.com/cs/ww/en/sc/2235>



Spare Parts Services

Spare Parts

Spare Parts Services are available worldwide for smooth and fast supply of spare parts – and thus optimal plant availability. Genuine spare parts are available for up to ten years. Logistic experts take care of procurement, transport, custom clearance, storage and order management.

Reliable logistics processes ensure that components reach their destination as needed.

Since not all spare parts can be kept in stock at all times, Siemens offers a preventive measure for spare parts provisioning on the customer's premises with optimized **Spare Parts Packages** for individual products, custom-assembled drive components and entire integrated drive trains – including risk consulting.

Asset Optimization Services help you design a strategy for parts supply where your investment and carrying costs are reduced and the risk of obsolescence is avoided.

<https://support.industry.siemens.com/cs/ww/en/sc/2110>



Repair Services

Repair Services

Repair Services are offered on-site and in regional repair centers for fast restoration of faulty devices' functionality.

Also available are extended repair services, which include additional diagnostic and repair measures, as well as emergency services.

<https://support.industry.siemens.com/cs/ww/en/sc/2154>



Field and Maintenance Services

Field and Maintenance Services

Siemens specialists are available globally to provide expert field and maintenance services, including commissioning, functional testing, preventive maintenance and fault clearance.

All services can be included in customized service agreements with defined reaction times or fixed maintenance intervals.

<https://support.industry.siemens.com/cs/ww/en/sc/2265>



Retrofit and Modernization Services

Retrofit and Modernization Services

Provide a cost-effective solution for the expansion of entire plants, optimization of systems or upgrading existing products to the latest technology and software, e.g. migration services for automation systems.

Service experts support projects from planning through commissioning and, if desired over the entire extended lifespan, e.g. Retrofit for Integrated Drive Systems for an extended lifetime of your machines and plants.

<https://support.industry.siemens.com/cs/ww/en/sc/2286>



Service Programs and Agreements

Service Programs and Agreements

A technical Service Program or Agreement enables you to easily bundle a wide range of services into a single annual or multi-year agreement.

You pick the services you need to match your unique requirements or fill gaps in your organization's maintenance capabilities.

Programs and agreements can be customized as KPI-based and/or performance-based contracts.

<https://support.industry.siemens.com/cs/ww/en/sc/2275>

Services and documentation

Industry Services

Online Support

Overview

Online Support – fast, intuitive, whenever you want, wherever you need

Web

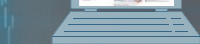

support.industry.siemens.com

App

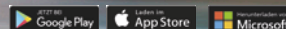

Scan the QR code for information on our Online Support app.



FAQ / Application examples

Information about industrial products, programming and configuration as well as application examples



Technical information

Videos, documentation, manuals, updates, product notes, compatibility tool, certificates, planning data such as dimensional drawings, product data, 3D models



Forum

Exchange information and experience with other users and experts

Online Support for Siemens Products for Industry

Siemens Industry and Online Support with some 1.7 million visitors per month is one of the most popular web services provided by Siemens. It is the central access point for comprehensive technical know-how about products, systems and services for automation and drives applications as well as for process industries.

In connection with the challenges and opportunities related to digitalization you can look forward to continued support with innovative offerings.

Overview



Your benefit from practical training directly from the manufacturer

SITRAIN – Training for Industry – provides you with comprehensive support in solving your tasks.

Training directly from the manufacturer enables you to make correct decisions with confidence.

Increased profits and lower costs:

- Shorter times for commissioning, maintenance and servicing
- Optimized production operations
- Reliable configuration and commissioning
- Shortened startup times, reduced downtimes, and faster troubleshooting
- Exclude expensive faulty planning right from the start.
- Flexible plant adaptation to market requirements
- Compliance with quality standards in production
- Increased employee satisfaction and motivation
- Shorter familiarization times following changes in technology and staff

Contact

Visit our site on the Internet at:
www.siemens.com/sitrain

or let us advise you personally.

SITRAIN – Training for Industry
SITRAIN Customer Support Germany:

Tel.: +49 911 895-7575

Fax: +49 911 895-7576

Email: info@sitrain.com

Your benefits with SITRAIN – Training for Industry

Certified top trainers

Our trainers are skilled specialists with practical experience. Course developers have close contact with product development, and pass on their knowledge to the trainers and then to you.

Practical application with practice

Practice, practice, practice! We have designed the trainings with an emphasis on practical exercises. They take up to half of the course time in our trainings. You can therefore implement your new knowledge in practice even faster.

300 courses in more than 60 countries

We offer a total of about 300 classroom-based courses. You can find us at more than 50 locations in Germany, and in 62 countries worldwide. You can find which course is offered at which location at:

www.siemens.com/sitrain

Skills development

Do you want to develop skills and fill in gaps in your knowledge? Our solution: We will provide a program tailored exactly to your personal requirements. After an individual requirements analysis, we will train you in our training centers near you or directly at your offices. You will practice on the most modern training equipment with special exercise units. The individual training courses are optimally matched to each other and help with the continuous development of knowledge and skills. After finishing a training module, the follow-up measures make success certain, as well as the refreshment and deepening of the knowledge gained.

Services and documentation

Training

Training courses for SINAMICS low-voltage converters

Overview

Training courses for SINAMICS drive system



This provides an overview of the training courses available for the SINAMICS drive system.

The courses are modular in design and are directed at a variety of target groups as well as individual customer requirements.

The system overview will acquaint decision-makers and sales personnel with the system very quickly.

The engineering course provides all the information you need to configure the drive system.

The courses dedicated to diagnostics and servicing, parameterization and commissioning, communication as well as extended functions such as Safety Integrated are sure to provide all the technical knowledge service engineers will need.

All courses contain as many practical exercises as possible to enable intensive and direct training on the drive system and with the tools in small groups.

Please also take note of the training options available for SIMOTICS motors. You will find more information about course contents and dates in Catalog ITC and on the Internet.

Title (all courses are available in English and German)	Target group			Duration	Order code
	Planners, decision-makers, sales personnel	Commissioning engineers, configuring engineers	Service personnel, maintenance technicians		
Courses Fundamentals and overview					
SINAMICS and SIMOTICS – Basics of drive technology	✓	✓	✓	5 days	DR-GAT
SINAMICS and SIMOTICS – System overview	✓	–	–	3 days	DR-SYS
SINAMICS System Overview	✓	–	–	2 days	DR-SN-UEB
Courses SINAMICS S120					
Planning and engineering	✓	–	–	5 days	DR-S12-PL
Parameterizing and commissioning	–	✓	–	5 days	DR-S12-PM
Parameterization Advanced Course	–	✓	–	5 days	DR-S12-PA
Parameterizing and optimizing	–	✓	–	3 days	DR-S12-OPT
Parameterizing Safety Integrated	–	✓	–	4 days	DR-S12-SAF
Diagnostics and service	–	–	✓	5 days	DR-S12-DG
Diagnostics at chassis and cabinet units	–	✓	✓	3 days	DR-S12-CHA
Diagnostics PROFINET and PROFIBUS	–	✓	✓	3 days	DR-S12-NET
Courses SINAMICS G120					
Planning and engineering	✓	–	–	2 days	DR-G12-PL
Parameterizing and commissioning	–	✓	–	2 days	DR-G12-PM
Parameterization Advanced Course	–	✓	–	3 days	DR-G12-PA
Parameterizing Safety Integrated	–	✓	–	2 days	DR-G12-SAF
Courses SINAMICS G120X					
Parameterizing and commissioning	–	✓	✓	1 day	DR-G12X-PM
Courses SINAMICS G130/G150/G180/S150					
DYNAVERT – commissioning and diagnostics	–	✓	✓	2 days	DR-DYNA
SINAMICS G150/G130/S150 – diagnostics and service	–	✓	✓	5 days	DR-G15-DG
SINAMICS G180 – diagnostics and service	–	–	✓	2.5 days	DR-G18-DG

Overview

SINAMICS G120XA training case

The SINAMICS G120XA training case is a convincing demonstration system thanks to its compact design. It is suitable for direct customer presentations as well as for tests in technical departments. It enables the functions of SINAMICS G120XA to be demonstrated and tested quickly and easily.

It contains the following components:

- SINAMICS G120XA frequency converter, USS, Modbus RTU, BACnet MS/TP, 0.75 kW
- Operator panels IOP-2 and BOP-2
- SINAMICS G120 Smart Access
- SIMOTICS GP asynchronous (induction) motor

The SINAMICS G120XA training case is supplied as a trolley with a hood.

Technical specifications

SINAMICS G120XA training case	
	6AG1067-2AA00-0AC2
Supply voltage	230 V 1 AC
Dimensions	
• Width	290 mm (11.42 in)
• Height	470 mm (18.50 in)
• Depth	300 mm (11.81 in)
Weight, approx.	16.9 kg (37.26 lb)

Selection and ordering data

Description	Article No.
SINAMICS G120XA training case	6AG1067-2AA00-0AC2

Services and documentation

Control cabinets

Overview

Complete equipment for machine tools and production systems

Our supplied range of products and services also includes complete equipment for machine tools and production systems with all services in the process chain from consulting through to after-sales service.

We support you in the areas of engineering, production and logistics.

Engineering support

Siemens supports you with advice on design in accordance with standards and concepts for drive systems, control, operation and safety.

Our engineers configure for you in EPLAN P8 and other commonly used CAD systems, execute projects designed to cost and adapt your documents where necessary to UL or new systems.

Our Technical Competence Center Cabinets in Chemnitz supports you with selecting and optimizing the suitable control cabinet air-conditioning system. Apart from calculation and simulation, we also use instrumentation testing in our heat laboratory with load simulation.

We also offer the following services:

- Vibration measurements and control cabinet certification in the field
- Measurement of conducted interference voltages in our laboratory



Cabinet engineering

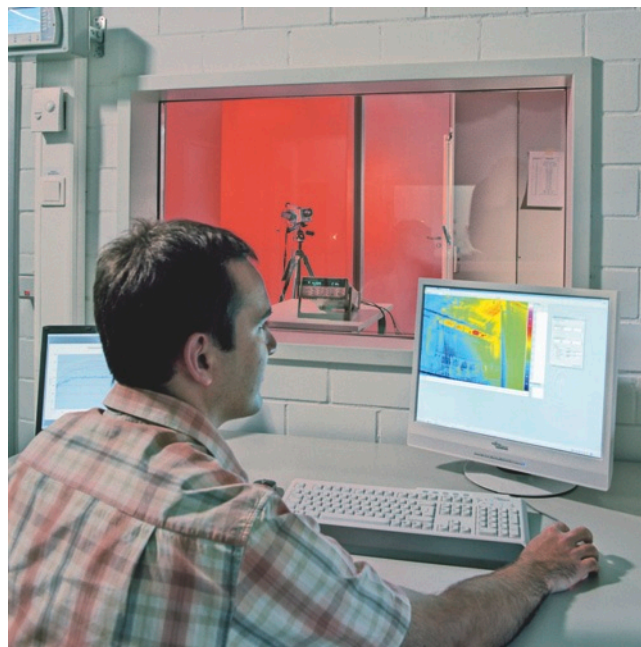

Testing in the heat laboratory

Production at a high level of quality

Complete equipment is manufactured at a high industrial level. This means:

- Examining consistency of the order documentation
- Checking for adherence to current regulations
- Collision check in 3D layout, taking into account the free space required thermally and electrically
- Automatic preparation of enclosures, cables and cable bundles
- Automated inspection and shipment free of faults
- Documentation and traceability
- Declaration of conformity regarding the Low-Voltage Directive and manufacturer's declaration on machinery directive
- UL label on request

Superior logistics

Everything from a single source offers you the following advantages:

- Cost savings for procurement, stockkeeping, financing
- Reduction in throughput times
- Just-in-time delivery

Individual support and maximum flexibility

Our technical consultants for complete equipment support customers and sales departments in the various regions. Our control cabinet customers are supported in the Systems Engineering Plant Chemnitz (WKC) by ordering centers and production teams that are permanently assigned to customers.

Distance does not present a problem; we also use web cams for consulting our customers.

Overview (continued)



Worldwide repair service

Customer-specific logistics models, flexible production capacity and production areas as well as change management in all process phases ensure maximum flexibility.

Customized supplementary products

As part of its complete equipment program, Siemens also offers the development and construction of customized supplementary products, e.g. special operator panels and power supply systems.

Liability for defects

Of course we accept the same liability for defects for our complete equipment as for our SINUMERIK and SINAMICS products.

Furthermore, you can use our worldwide repair service anywhere and at any time.

Your benefits

One partner, one quotation, one order, one delivery, one invoice, and one contact partner for liability of defects.

For series production or individual items, Siemens is your competent partner for complete equipment.

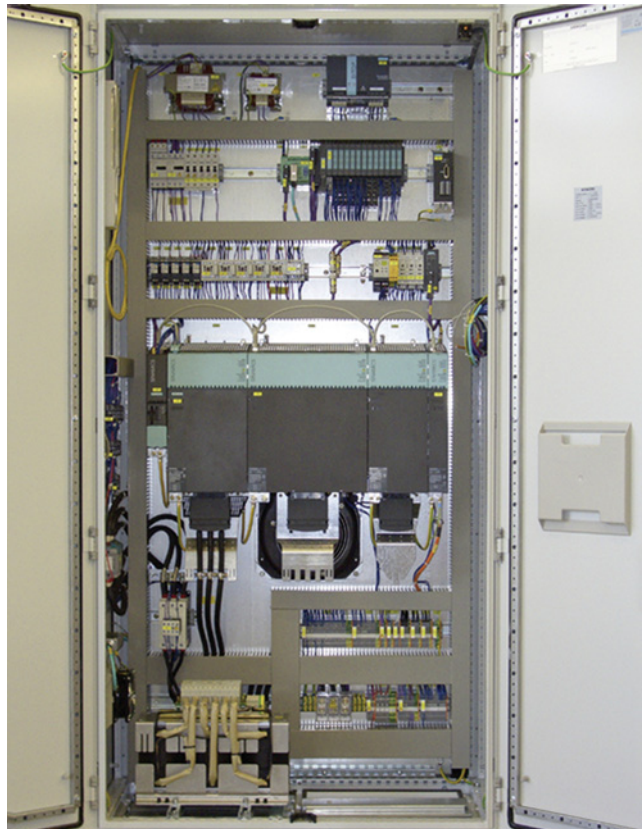

Control cabinet with SINAMICS S120 in booksize format

Services and documentation

Repair service contract RSC

Overview

RSC description of performance

Siemens provides for the machine manufacturer and dealer (in the following referred to as the "Customer") at the installation site of the machine the services specified below under Scope of services for components from Siemens DF & PD contained in the parts list of the RSC Certificate.

The RSC is ordered by the Customer who states the required article numbers that can be obtained from the Siemens sales partners or found in catalogs and the Industry Mall. The Customer receives from Siemens a certificate of delivery, which thus signifies the conclusion of the RSC.

After the Customer has provided the final destination notification, Siemens sends the Customer an RSC Certificate detailing the place of performance and the service period.

The services to be provided by Siemens are requested via a service order from the Customer. The service order must be submitted within the service period of the RSC.

Place of performance

The specified service is provided at the installation site of the machine (hereinafter referred to as "on-site"). This corresponds to the country of the end customer and the latter's full address, as specified in the final destination notification. Services covered by this RSC shall only be provided in those countries named in the RSC country list.

Scope of services

The following services shall be provided:

- Provision of service personnel
Siemens provides qualified personnel for the purpose of fault diagnostics and/or fault correction. The services are provided during the normal regional working hours in the country of installation.
- On-site fault diagnostics
Fault diagnostics applies to components from Siemens DF & PD as stated in the parts list in the RSC Certificate.
- Fault correction on-site
Fault correction is carried out by repairing and/or replacing defective components from Siemens DF & PD.
- Documentation of the fault correction
A service report is prepared on-site in the language of the end customer and shall be signed by the end customer. A copy of the report remains with the end customer.

Contract periods/service period

The RSC is offered for the period of liability (warranty period) of the Siemens customers to their end customers. Different RSC periods permit various market requirements to be addressed.

The service period of the RSC begins on the date notified to Siemens in the final destination notification when commissioning has been completed at the end customer's site and ends on expiry of the selected RSC term. The beginning and end of the performance period are stated in the RSC Certificate ¹⁾.

RSC Certificate

The Customer is provided with an RSC Certificate once the final destination notification has been handed over. This certificate shall contain the contract number and essential contract data such as machine number, machine type, parts list, beginning and end of the service period and the place of performance (address for the provision of services).

Service exclusions

The following is not included in the services:

- Complete motor spindles
- Services cannot be provided for wearing parts after the first 12 months of the contract period.
- Machine commissioning or optimization
- Masonry work, metalwork, breaking work and other non-electrical work
- Fault diagnostics and fault correction relating to faults that have occurred as a result of:
 - Non-compliance with the Siemens engineering and user guidelines, e.g. incorrect installation or grounding and incorrect operation or other improper treatment
 - Function-critical contamination, e.g. oil, conductive materials, rust
 - Mechanical damage
 - External electrical influences, for example, effects of overvoltage, non-reactor-protected power factor correction systems and/or line harmonics
 - Wanton destruction
 - Force majeure

¹⁾ For example, in the case of an RSC with 12 months contract period, maximum of 24 months from the transfer of risk (delivery of the components).

Overview (continued)

Country list

A repair service is offered for the following countries:

Continent	Country/region
Country group 1	
Americas	Mexico, USA
Asia	China, India, Japan, South Korea, Taiwan, Thailand
Australia	Australia
Europe	Andorra, Austria, Belgium, Czech Republic, Denmark, Finland, France, Germany, Great Britain, Hungary, Italy, Liechtenstein, Luxembourg, Monaco, the Netherlands, Poland, Portugal, Rumania, Slovak Republic, Spain, Sweden, Switzerland, Turkey
Country group 2	
Africa	South Africa
Americas	Brazil, Canada
Asia	Indonesia, Israel, Malaysia, Singapore
Australia	New Zealand
Europe	Bosnia-Herzegovina, Bulgaria, Croatia, Estonia, Ireland, Latvia, Lithuania, Norway, Slovenia
Country group 3	
Africa	Egypt
Americas	Argentina, Chile, Columbia, Ecuador, Peru, Venezuela
Asia	Bahrain, Hong Kong, Kuwait, Oman, Qatar, Saudi Arabia, United Arab Emirates (Dubai), Vietnam
Europe	Belarus, Greece, Malta, Russia, Serbia and Montenegro, Ukraine

Countries not listed, for customers with framework contracts only.

Response time

The following response times apply in general whenever services are provided under the RSC in the event of a machine standstill:

Country groups	
CG 1	Next working day
CG 2	Within two working days
CG 3	Depending on country-specific conditions
Countries not listed	Depending on country-specific conditions, only for customers with framework contracts for the price of the individual contract.

The response time is defined as the time between Siemens receiving the service order, technically clarified in advance by the Customer, and the Siemens service personnel commencing his travel to the place of performance or until troubleshooting commences using teleservice. The response times given apply to technically clarified service orders within the normal working hours of the region (e.g. Monday to Friday 8:00 to 17:00) excluding public holidays.

Spare parts

Spare parts are provided from our central spare parts warehouse or from regional spare parts warehouses using our worldwide spare parts logistics infrastructure. All of the essential spare parts are stocked in our central spare parts stores. Regional spare parts warehouses are adapted to include the components specified in the final destination certificate¹⁾.

The following components are not defined as spare parts:

- Motors: They are repaired at an authorized repair workshop. For selected motors, Siemens in Germany stocks components for express delivery. These motors can be manufactured and delivered within a few working days. You can obtain the current list from your Siemens sales partner.
- Cables: The delivery times known to you usually apply.
- Special or customer-specific modules and components not available from Siemens as spare parts.

The RSC shall only be processed in accordance with the terms and conditions applying to repair service contracts (RSC).

www.siemens.com/automation/rscagb

Benefits

- Protection against unknown costs for a fixed price
- RSC can be synchronized with the machine warranty period
- Planning certainty and calculable costs
- Easier processing in service cases
- High machine availability thanks to a fast response to machine faults (contract priority)
- Reduced downtimes thanks to stored product, final destination and contract information
- RSC can be ordered for machine deliveries to numerous countries
- Worldwide service infrastructure with experienced service staff

¹⁾ Since the export of standard versions (components/system) is subject to a time-consuming official approval procedure, which applies in equal measure to the supply of such components for the purpose of servicing and spare parts supply, we offer **an export version** for individual components. This has usually less options than the standard version of the component and is not subject to an export authorization. Please note the **information about export**.

Services and documentation

Repair service contract RSC

Types of contract for production machines

Overview



Data handling

To improve the service availability, Siemens DF & PD offers users the opportunity to register machines online and to save what is known as a identSNAPSHOT file. In addition to the component list and the software requirements of machines, this also includes information on machine manufacturers, and where relevant, dealers and end customers.

To simplify data handling, information about the final destination certificate can be saved using the XML function of identSNAPSHOT and transferred to Siemens using an online registration. This data can also be kept with the machine as data backup.

www.siemens.com/identsnapshot

Selection and ordering data

Description	Article No.
Repair service contract RSC	
For Siemens DF & PD components on production machines for countries in country groups 1 to 3	
• 12 month contract period ¹⁾	6FC8507-0RX12-■■■■0
• 24 month contract period ²⁾	6FC8507-0RX24-■■■■0
Equipment value in €	↑
0.–	0
100000.–	1
200000.–	2
300000.–	3
400000.–	4
500000.–	5
600000.–	6
700000.–	7
800000.–	8
900000.–	9
	↑
0.–	A
10000.–	B
20000.–	C
30000.–	D
40000.–	E
50000.–	F
60000.–	G
70000.–	H
80000.–	J
90000.–	K
	↑
0.–	A
1000.–	B
2000.–	C
3000.–	D
4000.–	E
5000.–	F
6000.–	G
7000.–	H
8000.–	J
9000.–	K

Ordering example:

Contract period of 12 months and equipment value €96000
6FC8507-0RX12-0KG0

¹⁾ Max. 24 months from the transfer of risk (delivery of components).

²⁾ Max. 36 months from the transfer of risk (delivery of components).

Overview



Our understanding of an application is the customer-specific solution of an automation task based on standard hardware and software components. In this respect, industry knowledge and technological expertise are just as important as expert knowledge about how our products and systems work. We are setting ourselves this challenge with more than 280 application engineers in 20 countries.

Application centers

We currently have application centers in:

- Germany: Head Office in Erlangen and in other German regions, e.g. in Munich, Nuremberg, Stuttgart, Mannheim, Frankfurt, Chemnitz, Cologne, Bielefeld, Bremen, Hanover, Hamburg
- Belgium: Brussels
- Brazil: Sao Paulo
- China: Beijing and 12 regions
- Denmark: Ballerup
- France: Paris
- Great Britain: Manchester
- India: Mumbai
- Italy: Bologna, Milan
- Japan: Tokyo, Osaka
- The Netherlands: The Hague
- Austria: Vienna
- Poland: Warsaw
- Sweden: Göteborg
- Switzerland: Zurich, Lausanne
- Spain: Madrid
- South Korea: Seoul
- Taiwan: Taipei
- Turkey: Istanbul
- USA: Atlanta

These application centers specialize in the use of SIMATIC/SIMOTION/SINAMICS. You therefore can rely on automation and drive specialists for implementing successful applications. By involving your personnel at an early stage in the process, we can provide a solid basis for rapid knowledge transfer, maintenance and further development of your automation solution.

Advice on applications and implementation

We offer a variety of consultation services to help you find the optimum solution for the SIMATIC/SIMOTION/SINAMICS application you want to implement:

The quotation phase includes

- clarification of technical questions,
- discussion of machine concepts and customer-specific solutions,
- selection of suitable technology and
- suggestions for implementation.

A technical feasibility study is also performed at the outset. In this way, difficult points of the application can be identified and solved early on. We can also configure and implement your application as a complete solution from a single source.

A large number of proven standard applications are available for use during the implementation phase. This saves engineering costs.

The system can be commissioned by experienced, competent personnel, if required. This saves time and trouble.

If servicing is required, we can support you on site or remotely. For further information about servicing, please see the section "Industry Services".

On-site application training

Training for the implemented applications can also be organized and carried out on site. This training for machine manufacturers and their customers does not deal with individual products, but the entire hardware and software system (for example, automation, drives and visualization).

From an initial concept to successful installation and commissioning: We provide complete support for SIMATIC/SIMOTION/SINAMICS! Contact your Siemens representative.

You can find further information at www.siemens.com/machinebuilding

Services and documentation

Spare parts services

Spare parts services during the lifecycle

Overview

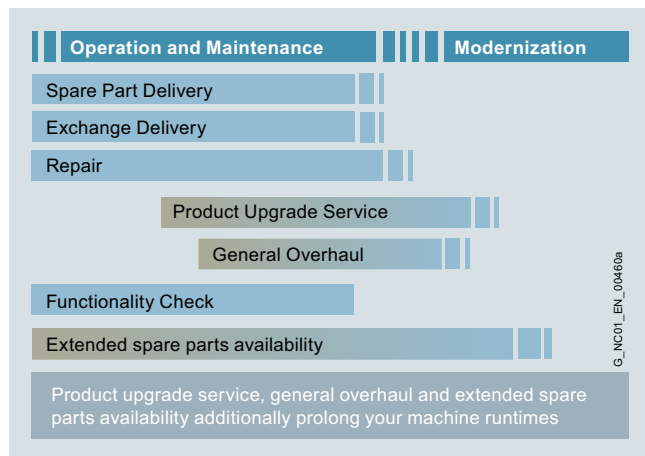

Spare parts services during the lifecycle

Siemens also provides constant support to customers after delivery of the machines or plant. This includes spare parts, repairs, as well as other supplementary services, and has a positive effect on machine operating times, inventories and costs.

When customers purchase a high-quality machine or plant, they intend to use it as intensively as possible, preferably for three shifts a day over many years. Under such circumstances, it is normal for parts to fail eventually. It is essential to replace the part as quickly as possible, because every hour of a plant stoppage costs money. To satisfy the multi-faceted requirements in the different areas, we have created comprehensive spare parts services.

Overview (continued)

You can sign up for the spare parts service that suits your requirements perfectly:

- Delivery of spare parts
- Delivery as exchange product
- Repair
- Product upgrade service
- General overhaul
- Function check
- Return of diagnostic parts
- Stock reduction of your spare parts store
- Extended spare parts availability

Benefits

- Optimum price/performance ratio and top quality
- Lifecycle management over the complete lifecycle
- Outstanding quality and availability of your machines and plant using Siemens original spare parts
- Global network and optimized logistics chains – 24 hours a day, 365 days a year
- Additional services from Siemens

More information

More information is available on the Internet at:

www.siemens.com/motioncontrol/spareparts

For further information, please approach your contact at your local Siemens office.

Contact information is available on the Internet at:

www.siemens.com/automation-contact

Delivery of spare parts

Overview

In every industry worldwide, plants and systems are required to operate with constantly increasing reliability. Lack of a specific spare part can result in considerable costs. We will provide you with the support you need to prevent a standstill from occurring in the first place: with a worldwide network and optimum logistics chains.

Ordering mode	Logistics service	Note
Standard	Cost-optimized: Contracted shipping company	Delivery within the normal national delivery times through the contracted shipping company
Plant stoppage	Time-optimized: Express, courier, collection	You choose the shortest possible delivery time for your own benefit: <ul style="list-style-type: none"> • Delivery by means of collection or courier service • Delivery by express service
Emergency service	Special logistics: Courier	You can also order the spare parts from us outside normal working hours, as well as on weekends or national holidays round-the-clock. <ul style="list-style-type: none"> • Your delivery will arrive by courier

Benefits

- New liability for defects for the spare part
- Long-term spare parts availability
- Optimum system compatibility

Overview

In addition to the simple delivery of spare parts, with many products, we also offer you the option of an exchange. This has the advantage that you not only receive the spare part quickly, but are able to return the defective device to us for a credit. You therefore receive our spare part at the lower exchange price.

A credit will be awarded on condition that the repair code indicates that repurchasing is admissible, a replacement is obtained from the spare parts store, and that the returned product is repairable.

The ordering mode and logistics service determine the delivery of spare parts:

Ordering mode	Logistics service	Note
Standard	Cost-optimized: Contracted shipping company	Delivery within the normal national delivery times through the contracted shipping company
Plant stoppage	Time-optimized: Express, courier, collection	You choose the shortest possible delivery time for your own benefit: <ul style="list-style-type: none"> • Delivery by means of collection or courier service • Delivery by express service
Emergency service	Special logistics: Courier	You can also order the spare parts from us outside normal working hours, as well as on weekends or national holidays round-the-clock. <ul style="list-style-type: none"> • Your delivery will arrive by courier

Overview (continued)

Return

For returns, we require the following information:

- Reason for return
- If defective: detailed description of the fault
- Machine number
- Machine/system manufacturer
- End customer

We will then be able to provide you with additional information in the repair report/inspection report regarding the diagnosis/inspection as well as information about the completed repair.

Benefits

- Savings thanks to the option of returning defective parts
- A spare part is available immediately in the event of failure
- New liability for defects for the spare part
- Long-term spare parts availability
- Optimum system compatibility

Repair

Overview

Downtimes cause problems in the plant as well as unnecessary costs. We can help you to reduce both to a minimum – with our worldwide repair facilities. The advantage for you: Defects can be rectified before they cause further harm.

Repair is a favorable option when you have specific reasons for not replacing the defective device or part with a new one (delivery as exchange product).

We maintain a global network of Siemens repair shops and certified partners to ensure that we will always be able to process your repairs quickly.

We can offer you different types of repair depending on your requirements:

Normal repair

Normal repair at standard conditions normally takes 10 working days following receipt of the defective item at our repair shop.

Fast repair

In particularly urgent cases, we offer you the option of a fast repair within 1 or 2 working days for many products at additional cost.

Turnaround repair

With a turnaround repair, we organize on your behalf collection of the device/component to be repaired.

Mobile repair service

We come to you and perform the required repairs on site, for example, when the device/component cannot be removed due to its weight.

Overview (continued)

Function repair

A function repair is the same as a normal repair but excludes the repair of cosmetic defects, e.g. scratches, labels, discoloration. The conditions applicable to function repairs should be observed in this case. The function repair service is only available for machine manufacturers or machine operators. Please ask your regional Siemens contact.

For repairs, we require the following information:

- Reason for return
- If defective: detailed fault report
- Machine number
- Machine/system manufacturer
- End customer

Benefits

- Short downtimes for machines and plants
- Only certified original parts are used
- Additional services from Siemens:
 - Longer availability of your machine/plant through the preventive replacement of wear parts and aging parts
 - Highest standards of quality
 - Use of the comprehensive test concept of series production, including software, firmware, ASICs, complex function blocks, etc.
 - Implementation of all the hardware and software/firmware enhancements known by development, production, service and quality management departments, as well as suppliers
- Information supplied by repair report/inspection report

Services and documentation

Spare parts services

Product upgrade service

Overview

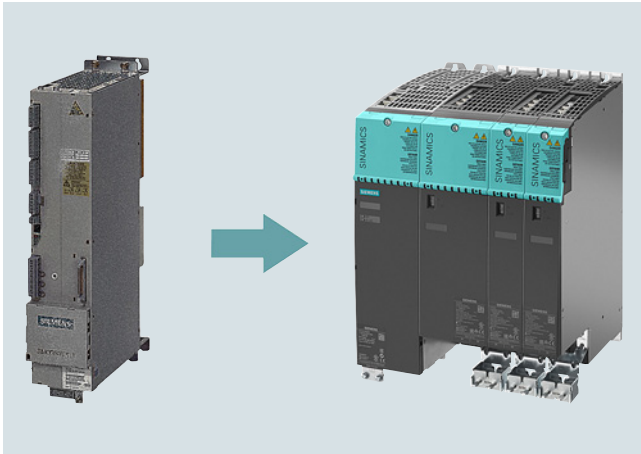

Product upgrade service: From OLD to NEW

A long service life is expected from machines and plants. The service life of the electronic components is, however, limited and normally shorter than the planned machine/plant operating times. To ensure that the required extended availability of the machine/plant is achieved, we offer you the product upgrade service at an attractive price.

In the course of their lifecycle, electronic components are normally redesigned/upgraded several times. With the product upgrade service, you will always receive the latest technology.

Overview (continued)

A planned product upgrade from OLD to NEW helps to prevent unplanned machine stoppages and supports a safer and longer machine/plant availability. The upgrade service is mainly offered for older components that will soon be discontinued.

For information about potential upgrades from the latest upgrade list, please ask your regional Siemens contact. The product upgrade service is only available for machine manufacturers or machine operators.

Benefits

- Price benefit through upgrade service
- New liability for defects for the new component
- Extended availability of your machine/plant
- Prevention of component failures due to wear and aging
- Prevention of machine stoppages due to unavailability of spare parts
- Reduced spare parts inventories
- Latest technology
- Easier servicing due to fewer variants
- Industry Services through Siemens are assured for the future

General overhaul

Overview

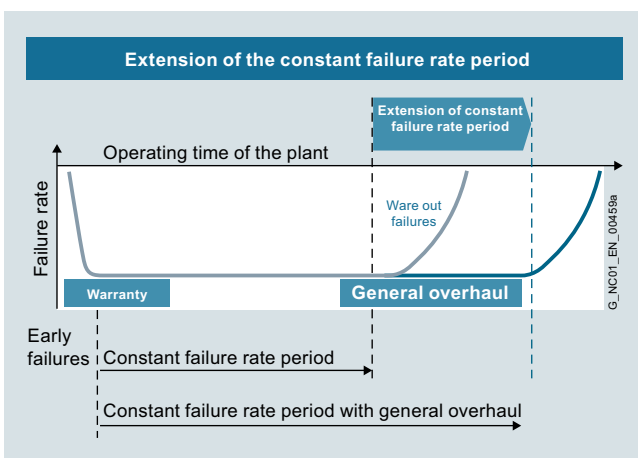

Extension of the period with a constant failure rate

A long service life is expected from machines and plants. The service life of electronic components and mechanical parts is, however, limited and normally shorter than the planned machine/plant operating times. For higher availability of the machines or plants, we offer a general overhaul (preventive maintenance) for electronic components and motors at favorable conditions.

Overview (continued)

During the planned general overhaul, wear parts and aging parts are replaced in accordance with their stated service life so as to reduce unplanned downtimes. In the case of motors, in addition to a general overhaul, replacement of bearings and encoders is also offered.

If a fault is detected during a general overhaul, troubleshooting and repair will be performed at the repair price without requesting confirmation or interrupting the process. In the case of extensive wear or damage, a general overhaul/repair will not be performed. A fixed lump sum for expenses will be charged in this case.

Benefits

- Preventive replacement of wear parts and aging parts in accordance with their stated service life
- Reduction in unplanned plant stoppages
- Enhanced production reliability
- Extended availability of your machine/plant
- New liability for defects for 12 months for the components subjected to a general overhaul
- Low price

Overview

It is checked that the components function reliably.

The first step involves cleaning the component. Then all the hardware and software/firmware enhancements are implemented that are known by development, production, service and quality management departments, as well as suppliers. Using the comprehensive test concept of series production, all the functions of the software, firmware, ASICs, complex and less complex function blocks are checked.

If a fault is detected during the function check, troubleshooting and repair will be performed at the repair price without requesting confirmation or interrupting the process. In the case of extensive wear or damage, no repairs will be performed. A fixed lump sum for expenses will be charged.

Benefits

- The component is checked and can be deployed again
- The component contains all the known improvements
- The customer's own spare parts stock is up-to-date
- Low price

Return of diagnostic parts

Overview



Spare parts used for diagnostic purposes from the spare parts store can be returned within 3 months and a credit note for up to 85 % is issued.

For unused spare parts in their original packaging, you will receive a credit of 100 % in which case you will be charged a fixed price for handling.

Benefits

- Can be used for diagnostics
- Reduced spare parts inventories
- Low costs

Services and documentation

Spare parts services

Stock reduction in spare parts store

Overview



Thanks to fast delivery of spare parts from Siemens, manufacturers and plant operators are able to reduce their spare parts inventories. Siemens offers an analysis for this purpose to indicate exactly which parts must be available in the customer's stores for a specific combination of machines and which should be obtained directly from Siemens.

Benefits

- Reduced costs
- Stock optimization
- Minimization of fault downtimes

4

Extended spare part availability

Overview

We normally retain spare parts for all products and systems for a period of 10 years after discontinuation of product marketing.

In individual cases, when we do not carry spare parts, we will offer a repair.

For a wide range of products and systems, we extend the availability of spare parts. We can provide you with the current spare parts availability for your machine/plant as a service once you have registered online with identSNAPSHOT.

www.siemens.com/identsnapshot

If you require longer availability of spare parts, please contact your regional sales representative.

Benefits

- Higher plant availability
- Investment protection
- Reduction of lifecycle costs



Overview

Spares on Web – online identification of spare parts

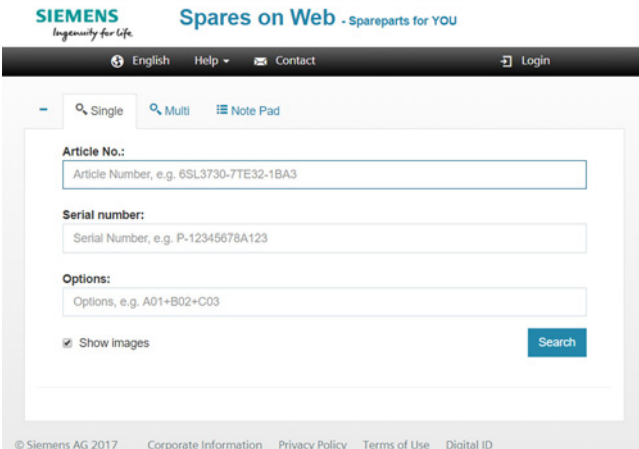

The screenshot displays the Siemens Spares on Web interface. At the top left is the Siemens logo with the tagline 'Ingenuity for Life'. The main heading is 'Spares on Web - Spareparts for YOU'. Below this is a navigation bar with 'English', 'Help', 'Contact', and 'Login'. The main content area has three tabs: 'Single', 'Multi', and 'Note Pad'. The 'Single' tab is active. It contains three input fields: 'Article No.' with a placeholder 'Article Number, e.g. 6SL3730-7TE32-1BA3', 'Serial number' with a placeholder 'Serial Number, e.g. P-12345678A123', and 'Options' with a placeholder 'Options, e.g. A01+B02+C03'. There is a 'Show images' checkbox and a 'Search' button. At the bottom, there is a footer with '© Siemens AG 2017' and links for 'Corporate Information', 'Privacy Policy', 'Terms of Use', and 'Digital ID'.

Spares on Web is a web-based tool for identifying spare parts. After you have entered the Article No. and serial number, the spare parts available for the relevant unit are displayed.

www.siemens.com/sow

Services and documentation

Product Partner – Drives Options

Overview

Siemens Product Partners for Drives Options

Individual options for our drives

In order to meet as many customer requirements as possible in the field of drive technology, in addition to its own products, Siemens also relies on the individual and complementary services of selected partners.

We are increasingly focusing on the standard drive options, and our Siemens Product Partners for Drives Options supplement our drives with individual drive options.

This gives Siemens a unique flexibility to meet all application requirements. Naturally, we support our Siemens Product Partners for Drives Options in tailoring their options perfectly to our drives.

For you as our customer, there are multiple benefits:

- The Siemens Product Partners for Drives Options meet the same high standards of quality and performance that we place on our own products
- Drive options can be adapted to individual requirements/designs
- The Siemens Product Partners for Drives Options know our Siemens converter portfolio and can advise you individually and quickly

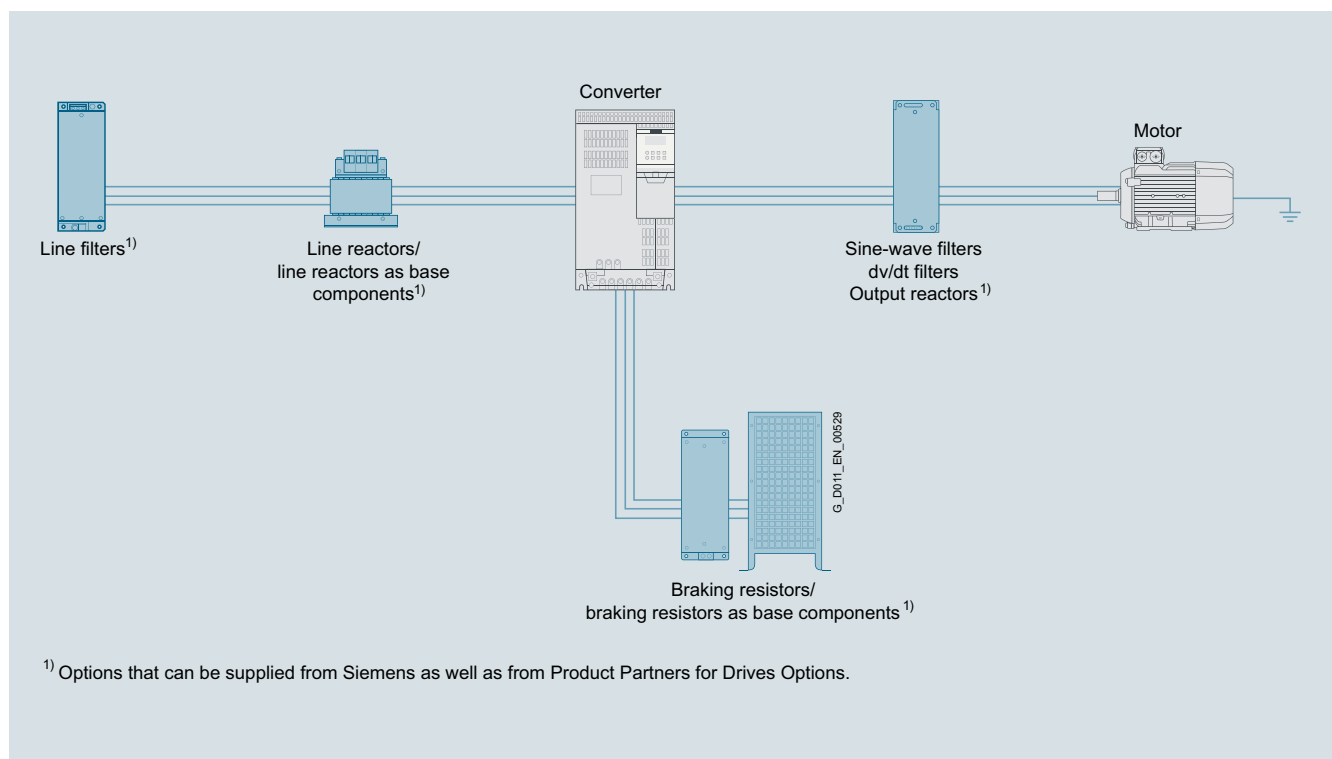

More information

You can find more information on the Internet at www.siemens.com/drives-options-partner

Overview

mySupport documentation – Compiling personal documents

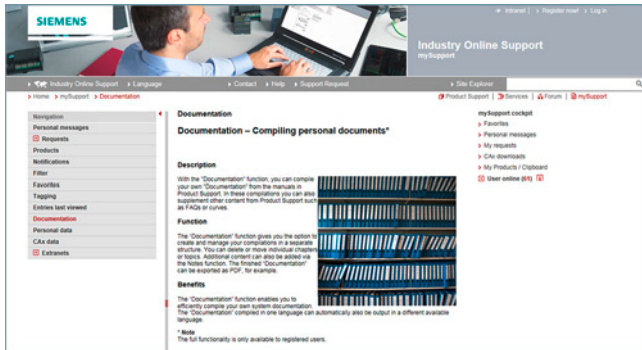

mySupport documentation is a web-based system for generating personalized documentation based on standard documents and is part of the Siemens Industry Online Support portal.

In mySupport, a personal document library can be created in the "Documentation" category. This library can be accessed online in mySupport or also be generated in various formats for offline use.

Previously, this functionality was available in the My Documentation Manager for configurable manuals. Due to the integration in mySupport, all entries of the Industry Online Support can now be imported into the personal document library, including FAQs or product notifications.

If you have already worked with the My Documentation Manager, all of the previously created libraries will continue to be available without restrictions in mySupport.

In addition, the personal library in mySupport can be shared with other mySupport users. In this way, a collection of relevant documents can be created very effectively and used together with other mySupport users all over the world.

You must register/log in for configuring and generating/managing.

Benefits

- Display
View, print or download standard documents or personalized documents
- Configure
Transfer standard documents or parts of them to personalized documents
- Generate/Manage
Generate and manage personalized documents in the formats PDF, RTF or XML in all available languages

Function

Opening mySupport documentation in the Industry Online Support portal

- About the product support, entry type "Manual":
<https://support.industry.siemens.com/cs/ww/en/ps/manual>
By clicking on the required version of the manual and then "Show and configure", the manual opens in a modular view, where you can navigate from topic to topic. Here the direct link to a topic can be used and made available to other users. The selected document can be added to the personal library via "mySupport Cockpit" > "Add to mySupport documentation".
- Via the direct link
<https://support.industry.siemens.com/my/ww/en/documentation/advanced>
After login/registration, the online help is displayed as the current document.

More information

You can find additional information on the Internet at

- <https://support.industry.siemens.com/my/ww/en/documentation>
- https://support.industry.siemens.com/cs/helpcenter/en/index.htm?#persoenliche_bibliothek_aufbauen.htm

Services and documentation

Documentation

General documentation

Overview

A high-quality programmable control or drive system can be used to maximum effect only if the user is aware of the performance of the products used as a result of intensive training and good technical documentation.

This is becoming more important due to the shorter innovation cycles of modern automation products and the convergence of electronics and mechanical engineering.

A comprehensive range of documentation is available which includes a Getting Started guide, operating instructions, installation manuals and a list manual.

The documents are available in hardcopy form or as a PDF file for downloading from the Internet.

Information and documentation relating to SINUMERIK, SINAMICS, SIMOTION and SIMOTICS are available on the Internet at

<https://support.industry.siemens.com/cs/document/109476679>

In addition to many other useful documents, the Information and Download Center also contains catalogs about the following systems:

- SINUMERIK: NC 62, NC 81.1, NC 82
- SINAMICS: D 11, D 12, D 21.3, D 21.4, D 23.1, D 23.2, D 31.1, D 31.2, D 31.5, D 32, D 33, D 35
- SIMOTION: PM 21
- SIMOTICS: D 21.4, D 41, D 81.1, D 81.8, D 83.1

You can download these catalogs in PDF format – you don't need to log on. You can perform a targeted search using the filter box above the first displayed catalog. By entering the search term "NC 8", for example, you can locate Catalog NC 81.1 and Catalog NC 82, and by entering "ST 70" you will find Catalog ST 70 as well as the relevant news and add-ons (if available).

www.siemens.com/industry/infocenter

Application

Explanations of the manuals:

- **Operating Instructions**
contain all the information needed to install the device and make electrical connections, information about commissioning and a description of the converter functions.
Phases of use: Control cabinet construction, commissioning, operation, maintenance and servicing.
- **Hardware Installation Manual**
contains all relevant information about the intended use of the components of a system (technical specifications, interfaces, dimensional drawings, characteristics, or possible applications), information about installation and electrical connections and information about maintenance and servicing.
Phases of use: Control cabinet configuration/construction, maintenance and servicing.
- **Operating and Installation Instructions**
(for converter and accessories)
contain all relevant information about the intended use of the components, such as technical specifications, interfaces, dimensional drawings, characteristics, or possible applications.
Phases of use: Control cabinet configuration/construction.
- **Manual/Configuration Manual**
contains all necessary information about the intended use of the components of a system, e.g. technical specifications, interfaces, dimensional drawings, characteristics, or possible applications.
Phases of use: Cabinet configuration/setup, circuit diagram configuration/drawing.
- **Commissioning Manual**
contains all information relevant to commissioning after installation and wiring. It also contains all safety and warning notices relevant to commissioning in addition to overview drawings.
Phases of use: Commissioning of components that have already been connected, configuration of system functions.
- **List Manual**
contains all parameters, function diagrams, and faults/alarms for the product/system as well as their meanings and setting options. It contains parameter data and fault/alarm descriptions with functional correlations.
Phases of use: Commissioning of components that have already been connected, configuration of system functions, fault cause/diagnosis.
- **Getting Started**
provides information about getting started for the first-time user as well as references to additional information. It contains information about the basic steps to be taken during commissioning. The information in the other documentation should be carefully observed for all of the other work required.
Phases of use: Commissioning of components that have already been connected.
- **Function Manual Drive Functions**
contains all the relevant information about individual drive functions: Description, commissioning and integration in the drive system.
Phases of use: Commissioning of components that have already been connected, configuration of system functions.

Selection and ordering data

Description	Article No.
Configuration Manual EMC Installation Guideline SIMOCRANE, SIMOTICS, SIMOTION, SINAMICS, SINUMERIK <ul style="list-style-type: none"> • German • English • Italian • French • Spanish • Chinese Simplified 	6FC5297-0AD30-0AP3 6FC5297-0AD30-0BP3 6FC5297-0AD30-0CP3 6FC5297-0AD30-0DP3 6FC5297-0AD30-0EP3 6FC5297-0AD30-0RP3

SINAMICS G120XA documentation

Overview

Compact Installation Instructions are supplied in hard copy form in German and English with every SINAMICS G120XA. Further documentation, such as the operating instructions, is available free on the Internet at:
www.siemens.com/sinamics-g120xa/documentation

Detailed information on the SINAMICS G120XA infrastructure converters for standard pumps/fans, including the latest technical documentation (brochures, tutorials, dimensional drawings, certificates and operating instructions), is available on the Internet at:

www.siemens.com.cn/sinamics-g120xa

and is also available via the Drive Technology Configurator (DT Configurator) on the Internet.

The DT Configurator can be found in the Siemens Industry Mall at the following address:

www.siemens.com.cn/dt-configurator

Services and documentation

Documentation

Notes

4

Appendix



5/2	Certificates of suitability (approvals)
5/4	Software licenses
5/6	Conversion tables
5/8	Metal surcharges
5/11	Conditions of sale and delivery

Appendix

Certificates of suitability (approvals)







Overview

Many of the products in this catalog fulfill requirements, e.g. for UL, CSA or FM and are labeled with the corresponding approval designation.

All of the certificates of suitability, approvals, certificates, declarations of conformity, test certificates, e.g. CE, UL, Safety Integrated etc. have been performed with the associated system components as they are described in the Catalogs and Configuration Manuals.

The certificates are only valid if the products are used with the described system components, are installed according to the Installation Guidelines and used for their intended purpose.

In other cases, the vendor of these products is responsible for arranging for the issue of new certificates.

Test code	Tested by	Device series/ Component	Test standard	Product category/ File No.
UL: Underwriters Laboratories Independent public testing body in North America				
	UL according to UL standard	SINUMERIK	Standard UL 508, CSA C22.2 No. 142	NRAQ/7.E164110 NRAQ/7.E217227
		SIMOTION	Standard UL 508, CSA C22.2 No. 142	NRAQ/7.E164110
	UL according to CSA standard	SINAMICS	Standard UL 508, 508C, 61800-5-1 CSA C22.2 No. 142, 274	NRAQ/7.E164110, NMMS/2/7/8.E192450, NMMS/7.E203250, NMMS/7.E214113, NMMS/7.E253831
	UL according to UL and CSA standards			NMMS/2/7/8.E121068 NMMS/7.E355661 NMMS/7.E323473
	UL according to UL standard	SIMODRIVE	Standard UL 508C, CSA C22.2 No. 274	NMMS/2/7/8.E192450 NMMS/7.E214113
	UL according to CSA standard	SIMOTICS	Standard UL 1004-1, 1004-6, 1004-8, CSA C22.2 No. 100	PRGY2/8.E227215 PRHZ2/8.E93429 PRHJ2/8.E342747 PRGY2/8.E253922 PRHZ2/8.E342746
	UL according to UL and CSA standards			
		Line/motor reactors	Standard UL 508, 506, 5085-1, 5085-2, 1561, CSA C22.2 No. 14, 47, 66.1-06, 66.2-06	XQNX2/8.E257859 NMTR2/8.E219022 NMMS2/8.E333628 XPTQ2/8.E257852 XPTQ2/8.E103521 NMMS2/8.E224872 XPTQ2/8.E354316 XPTQ2/8.E198309 XQNX2/8.E475972
		Line filters, dv/dt filters, sine-wave filters	UL 1283, CSA C22.2 No. 8	FOKY2/8.E70122
		Resistors	UL 508, 508C, CSA C22.2 No. 14, 274	NMTR2/8.E224314 NMMS2/8.E192450 NMTR2/8.E221095 NMTR2/8.E226619
TUV: TÜV Rheinland of North America Inc. Independent public testing body in North America, Nationally Recognized Testing Laboratory (NRTL)				
TÜV: TÜV SÜD Product Service Independent public testing body in Germany, Nationally Recognized Testing Laboratory (NRTL) for North America				
	TUV according to UL and CSA standards	SINAMICS	NRTL listing according to standard UL 508C	U7V 12 06 20078 013 U7 11 04 20078 009 U7 11 04 20078 010 U7 11 04 20078 011
		SIMOTION	NRTL listing according to standard UL 508	U7V 13 03 20078 01
		SIMODRIVE	NRTL listing according to standard UL 508C, CSA C22.2. No. 14	CU 72090702
		Motion Control Encoder	NRTL listing according to UL 61010-1 CSA C22.2 No. 61010-1	U8V 10 06 20196 024

Certificates of suitability (approvals)

Overview (continued)

Test code	Tested by	Device series/ Component	Test standard	Product category/ File No.
CSA: Canadian Standards Association Independent public testing body in Canada				
	CSA according to CSA standard	SINUMERIK	Standard CSA C22.2 No. 142	2252-01 : LR 102527
FMRC: Factory Mutual Research Corporation Independent public testing body in North America				
	FM according to FM standard	SINUMERIK	Standard FMRC 3600, FMRC 3611, FMRC 3810, ANSI/ISA S82.02.1	–
EAC: Ivanovo-Certificate Independent public testing body in the Russian Federation				
	EAC in accordance with the EAC Directive	SINAMICS SINUMERIK SIMOTION	Standard IEC 61800-5-1/-2, IEC 61800-3	–
RCM: Australian Communications and Media Authority Independent public testing body in Australia				
	RCM according to EMC standard	SINAMICS SINUMERIK SIMOTION	Standard IEC AS 61800-3, EN 61800-3	–
KC: National Radio Research Agency Independent public testing body in South Korea				
	KC according to EMC standard	SINAMICS SINUMERIK SIMOTION	Standard KN 11	–
BIA Federal Institute for Occupational Safety				
–	Functional safety	SINAMICS SINUMERIK SIMOTION	Standard EN 61800-5-2	–
TÜV SÜD Rail				
–	Functional safety	SINAMICS SINUMERIK SIMOTION	Standard EN 61800-5-2	–

More information about certificates can be found online at:
<https://support.industry.siemens.com/cs/ww/en/ps/cert>

Appendix

Software licenses

Overview

Software types

Software requiring a license is categorized into types. The following software types have been defined:

- Engineering software
- Runtime software

Engineering software

This includes all software products for creating (engineering) user software, e.g. for configuring, programming, parameterizing, testing, commissioning or servicing.

Data generated with engineering software and executable programs can be duplicated for your own use or for use by third-parties free-of-charge.

Runtime software

This includes all software products required for plant/machine operation, e.g. operating system, basic system, system expansions, drivers, etc.

The duplication of the runtime software and executable programs created with the runtime software for your own use or for use by third-parties is subject to a charge.

You can find information about license fees according to use in the ordering data (e.g. in the catalog). Examples of categories of use include per CPU, per installation, per channel, per instance, per axis, per control loop, per variable, etc.

Information about extended rights of use for parameterization/configuration tools supplied as integral components of the scope of delivery can be found in the readme file supplied with the relevant product(s).

License types

Siemens Industry Automation & Drive Technologies offers various types of software license:

- Floating license
- Single license
- Rental license
- Rental floating license
- Trial license
- Demo license
- Demo floating license

Floating license

The software may be installed for internal use on any number of devices by the licensee. Only the concurrent user is licensed. The concurrent user is the person using the program. Use begins when the software is started. A license is required for each concurrent user.

Single license

Unlike the floating license, a single license permits only one installation of the software per license.

The type of use licensed is specified in the ordering data and in the Certificate of License (CoL). Types of use include for example per instance, per axis, per channel, etc.

One single license is required for each type of use defined.

Rental license

A rental license supports the "sporadic use" of engineering software. Once the license key has been installed, the software can be used for a specific period of time (the operating hours do not have to be consecutive).

One license is required for each installation of the software.

Rental floating license

The rental floating license corresponds to the rental license, except that a license is not required for each installation of the software. Rather, one license is required per object (for example, user or device).

Trial license

A trial license supports "short-term use" of the software in a non-productive context, e.g. for testing and evaluation purposes. It can be transferred to another license.

Demo license

The demo license support the "sporadic use" of engineering software in a non-productive context, for example, use for testing and evaluation purposes. It can be transferred to another license. After the installation of the license key, the software can be operated for a specific period of time, whereby usage can be interrupted as often as required.

One license is required per installation of the software.

Demo floating license

The demo floating license corresponds to the demo license, except that a license is not required for each installation of the software. Rather, one license is required per object (for example, user or device).

Certificate of License (CoL)

The CoL is the licensee's proof that the use of the software has been licensed by Siemens. A CoL is required for every type of use and must be kept in a safe place.

Downgrading

The licensee is permitted to use the software or an earlier version/release of the software, provided that the licensee owns such a version/release and its use is technically feasible.

Delivery versions

Software is constantly being updated. The following delivery versions

- PowerPack
- Upgrade

can be used to access updates.

Existing bug fixes are supplied with the ServicePack version.

PowerPack

PowerPacks can be used to upgrade to more powerful software. The licensee receives a new license agreement and CoL (Certificate of License) with the PowerPack. This CoL, together with the CoL for the original product, proves that the new software is licensed.

A separate PowerPack must be purchased for each original license of the software to be replaced.

Overview (continued)**Upgrade**

An upgrade permits the use of a new version of the software on the condition that a license for a previous version of the product is already held.

The licensee receives a new license agreement and CoL with the upgrade. This CoL, together with the CoL for the previous product, proves that the new version is licensed.

A separate upgrade must be purchased for each original license of the software to be upgraded.

ServicePack

ServicePacks are used to debug existing products. ServicePacks may be duplicated for use as prescribed according to the number of existing original licenses.

License key

Siemens Industry Automation & Drive Technologies supplies software products with and without license keys.

The license key serves as an electronic license stamp and is also the "switch" for activating the software (floating license, rental license, etc.).

The complete installation of software products requiring license keys includes the program to be licensed (the software) and the license key (which represents the license).

Software Update Service (SUS)

As part of the SUS contract, all software updates for the respective product are made available to you free of charge for a period of one year from the invoice date. The contract will automatically be extended for one year if it is not canceled three months before it expires.

The possession of the current version of the respective software is a basic condition for entering into an SUS contract.

You can download explanations concerning license conditions from

www.siemens.com/automation/salesmaterial-as/catalog/en/terms_of_trade_en.pdf

Appendix

Conversion tables

Rotary inertia (to convert from A to B, multiply by entry in table)

A \ B	lb-in ²	lb-ft ²	lb-in-s ²	lb-ft-s ² slug-ft ²	kg-cm ²	kg-cm-s ²	gm-cm ²	gm-cm-s ²	oz-in ²	oz-in-s ²
lb-in ²	1	6.94×10^{-3}	2.59×10^{-3}	2.15×10^{-4}	2.926	2.98×10^{-3}	2.92×10^3	2.984	16	4.14×10^{-2}
lb-ft ²	144	1	0.3729	3.10×10^{-2}	421.40	0.4297	4.21×10^5	429.71	2304	5.967
lb-in-s ²	386.08	2.681	1	8.33×10^{-2}	1.129×10^3	1.152	1.129×10^6	1.152×10^3	6.177×10^3	16
lb-ft-s ² slug-ft ²	4.63×10^3	32.17	12	1	1.35×10^4	13.825	1.355×10^7	1.38×10^4	7.41×10^4	192
kg-cm ²	0.3417	2.37×10^{-3}	8.85×10^{-4}	7.37×10^{-5}	1	1.019×10^{-3}	1000	1.019	5.46	1.41×10^{-2}
kg-cm-s ²	335.1	2.327	0.8679	7.23×10^{-2}	980.66	1	9.8×10^5	1000	5.36×10^3	13.887
gm-cm ²	3.417×10^{-4}	2.37×10^{-6}	8.85×10^{-7}	7.37×10^{-8}	1×10^{-3}	1.01×10^{-6}	1	1.01×10^{-3}	5.46×10^{-3}	1.41×10^{-5}
gm-cm-s ²	0.335	2.32×10^{-3}	8.67×10^{-4}	7.23×10^{-5}	0.9806	1×10^{-3}	980.6	1	5.36	1.38×10^{-2}
oz-in ²	0.0625	4.34×10^{-4}	1.61×10^{-4}	1.34×10^{-5}	0.182	1.86×10^{-4}	182.9	0.186	1	2.59×10^{-3}
oz-in-s ²	24.13	0.1675	6.25×10^{-2}	5.20×10^{-3}	70.615	7.20×10^{-2}	7.09×10^4	72.0	386.08	1

Torque (to convert from A to B, multiply by entry in table)

A \ B	lb-in	lb-ft	oz-in	N-m	kg-cm	kg-m	gm-cm	dyne-cm
lb-in	1	8.333×10^{-2}	16	0.113	1.152	1.152×10^{-2}	1.152×10^3	1.129×10^6
lb-ft	12	1	192	1.355	13.825	0.138	1.382×10^4	1.355×10^7
oz-in	6.25×10^{-2}	5.208×10^{-3}	1	7.061×10^{-3}	7.200×10^{-2}	7.200×10^{-4}	72.007	7.061×10^4
N-m	8.850	0.737	141.612	1	10.197	0.102	1.019×10^4	1×10^7
kg-cm	0.8679	7.233×10^{-2}	13.877	9.806×10^{-2}	1	10^{-2}	1000	9.806×10^5
kg-m	86.796	7.233	1.388×10^3	9.806	100	1	1×10^5	9.806×10^7
gm-cm	8.679×10^{-4}	7.233×10^{-5}	1.388×10^{-2}	9.806×10^{-5}	1×10^{-3}	1×10^{-5}	1	980.665
dyne-cm	8.850×10^{-7}	7.375×10^{-8}	1.416×10^{-5}	10^{-7}	1.0197×10^{-6}	1.019×10^{-8}	1.019×10^{-3}	1

Length (to convert from A to B, multiply by entry in table)

A \ B	inches	feet	cm	yd	mm	m
inches	1	0.0833	2.54	0.028	25.4	0.0254
feet	12	1	30.48	0.333	304.8	0.3048
cm	0.3937	0.03281	1	1.09×10^{-2}	10	0.01
yd	36	3	91.44	1	914.4	0.914
mm	0.03937	0.00328	0.1	1.09×10^{-3}	1	0.001
m	39.37	3.281	100	1.09	1000	1

Force (to convert from A to B, multiply by entry in table)

A \ B	lb	oz	gm	dyne	N
lb	1	16	453.6	4.448×10^5	4.4482
oz	0.0625	1	28.35	2.780×10^4	0.27801
gm	2.205×10^{-3}	0.03527	1	1.02×10^{-3}	N.A.
dyne	2.248×10^{-6}	3.59×10^{-5}	980.7	1	0.00001
N	0.22481	3.5967	N.A.	100000	1

Mass (to convert from A to B, multiply by entry in table)

A \ B	lb	oz	gm	kg	slug
lb	1	16	453.6	0.4536	0.0311
oz	6.25×10^{-2}	1	28.35	0.02835×10^{-3}	1.93×10^{-3}
gm	2.205×10^{-3}	3.527×10^{-2}	1	10^{-3}	6.852×10^{-5}
kg	2.205	35.27	10^3	1	6.852×10^{-2}
slug	32.17	514.8	1.459×10^4	14.59	1

Rotation (to convert from A to B, multiply by entry in table)

A \ B	rpm	rad/s	degrees/s
rpm	1	0.105	6.0
rad/s	9.55	1	57.30
degrees/s	0.167	1.745×10^{-2}	1

Temperature Conversion

°F	°C	°C	°F
0	-17.8	-10	14
32	0	0	32
50	10	10	50
70	21.1	20	68
90	32.2	30	86
98.4	37	37	98.4
212	100	100	212
subtract 32 and multiply by $\frac{5}{9}$		multiply by $\frac{9}{5}$ and add 32	

Mechanism Efficiencies

Acme-screw with brass nut	~0.35–0.65
Acme-screw with plastic nut	~0.50–0.85
Ball-screw	~0.85–0.95
Chain and sprocket	~0.95–0.98
Preloaded ball-screw	~0.75–0.85
Spur or bevel-gears	~0.90
Timing belts	~0.96–0.98
Worm gears	~0.45–0.85
Helical gear (1 reduction)	~0.92

Friction Coefficients

Materials	μ
Steel on steel (greased)	~0.15
Plastic on steel	~0.15–0.25
Copper on steel	~0.30
Brass on steel	~0.35
Aluminum on steel	~0.45
Steel on steel	~0.58
Mechanism	μ
Ball bushings	<0.001
Linear bearings	<0.001
Dove-tail slides	~0.2++
Gibb ways	~0.5++

Material Densities

Material	lb-in ³	gm-cm ³
Aluminum	0.096	2.66
Brass	0.299	8.30
Bronze	0.295	8.17
Copper	0.322	8.91
Hard wood	0.029	0.80
Soft wood	0.018	0.48
Plastic	0.040	1.11
Glass	0.079–0.090	2.2–2.5
Titanium	0.163	4.51
Paper	0.025–0.043	0.7–1.2
Polyvinyl chloride	0.047–0.050	1.3–1.4
Rubber	0.033–0.036	0.92–0.99
Silicone rubber, without filler	0.043	1.2
Cast iron, gray	0.274	7.6
Steel	0.280	7.75

Wire Gauges¹⁾

Cross-section mm ²	Standard Wire Gauge (SWG)	American Wire Gauge (AWG)
0.2	25	24
0.3	23	22
0.5	21	20
0.75	20	19
1.0	19	18
1.5	17	16
2.5	15	13
4	13	11
6	12	9
10	9	7
16	7	6
25	5	3
35	3	2
50	0	1/0
70	000	2/0
95	00000	3/0
120	0000000	4/0
150	–	6/0
185	–	7/0

¹⁾ The table shows approximate SWG/AWG sizes nearest to standard metric sizes; the cross-sections do not match exactly.

Appendix

Metal surcharges

Explanation of the raw material/metal surcharges ¹⁾

Surcharge calculation

To compensate for variations in the price of the raw materials silver, copper, aluminum, lead, gold, dysprosium ²⁾ and/or neodym ²⁾, surcharges are calculated on a daily basis using the so-called metal factor for products containing these raw materials. A surcharge for the respective raw material is calculated as a supplement to the price of a product if the basic official price of the raw material in question is exceeded.

The surcharges are calculated in accordance with the following criteria:

- Basic official price of the raw material
Basic official price from the day prior to receipt of the order or prior to release order (daily price) for ³⁾
- Silver (sales price, processed)
- Gold (sales price, processed)
and for ⁴⁾
- Copper (lower DEL notation + 1 %)
- Aluminum (aluminum in cables)
- Lead (lead in cables)
- Metal factor of the products
Certain products are displayed with a metal factor. The metal factor determines the official price (for those raw materials concerned) as of which the metal surcharges are applied and the calculation method used (weight or percentage method). An exact explanation is given below.

Structure of the metal factor

The metal factor consists of several digits; the first digit indicates whether the percentage method of calculation refers to the list price or a possible discounted price (customer net price) (L = list price / N = customer net price).

The remaining digits indicate the method of calculation used for the respective raw material. If no surcharge is added for a raw material, a "-" is used.

1st digit	List or customer net price using the percentage method
2nd digit	for silver (AG)
3rd digit	for copper (CU)
4th digit	for aluminum (AL)
5th digit	for lead (PB)
6th digit	for gold (AU)
7th digit	for dysprosium (Dy) ²⁾
8th digit	for neodym (Nd) ²⁾

Weight method

The weight method uses the basic official price, the daily price and the raw material weight. In order to calculate the surcharge, the basic official price must be subtracted from the daily price. The difference is then multiplied by the raw material weight.

The basic official price can be found in the table below using the number (1 to 9) of the respective digit of the metal factor. The raw material weight can be found in the respective product descriptions.

Percentage method

Use of the percentage method is indicated by the letters A-Z at the respective digit of the metal factor.

The surcharge is increased - dependent on the deviation of the daily price compared with the basic official price - using the percentage method in "steps" and consequently offers surcharges that remain constant within the framework of this "step range". A higher percentage rate is charged for each new step. The respective percentage level can be found in the table below.

Metal factor examples

L E A - - - - -	Basis for % surcharge: List price Silver Basis 150 €, Step 50 €, 0.5 % Copper Basis 150 €, Step 50 €, 0.1 % No surcharge for aluminum No surcharge for lead No surcharge for gold No surcharge for dysprosium No surcharge for neodym
N - A 6 - - - - -	Basis for % surcharge: Customer net price No surcharge for silver Copper Basis 150 €, Step 50 €, 0.1 % Aluminum acc. to weight, basic offic. price 225 € No surcharge for lead No surcharge for gold No surcharge for dysprosium No surcharge for neodym
- - - 3 - - - - -	No basis necessary No surcharge for silver Copper acc. to weight, basic official price 150 € No surcharge for aluminum No surcharge for lead No surcharge for gold No surcharge for dysprosium No surcharge for neodym

1) Refer to the separate explanation on the next page regarding the raw materials dysprosium and neodym (= rare earths).

2) For a different method of calculation, refer to the separate explanation for these raw materials on the next page.

3) Source: Umicore, Hanau (www.metalsmanagement.umicore.com).

4) Source: Schutzvereinigung DEL-Notiz e.V. (www.del-notiz.org).

Explanation of the raw material/metal surcharges for dysprosium and neodym (rare earths)

Surcharge calculation

To compensate for variations in the price of the raw materials silver ¹⁾, copper ¹⁾, aluminum ¹⁾, lead ¹⁾, gold ¹⁾, dysprosium and/or neodym, surcharges are calculated on a daily basis using the so-called metal factor for products containing these raw materials. The surcharge for dysprosium and neodym is calculated as a supplement to the price of a product if the basic official price of the raw material in question is exceeded.

The surcharge is calculated in accordance with the following criteria:

- Basic official price of the raw material ²⁾
Three-month basic average price (see below) in the period before the quarter in which the order was received or the release order took place (= average official price) for
- dysprosium (Dy metal, 99 % min. FOB China; USD/kg)
- neodym (Nd metal, 99 % min. FOB China; USD/kg)
- Metal factor of the products
Certain products are displayed with a metal factor. The metal factor indicates (for those raw materials concerned) the basic official price as of which the surcharges for dysprosium and neodym are calculated using the weight method. An exact explanation of the metal factor is given below.

Three-month average price

The prices of rare earths vary according to the foreign currency, and there is no freely accessible stock exchange listing. This makes it more difficult for all parties involved to monitor changes in price. In order to avoid continuous adjustment of the surcharges, but to still ensure fair, transparent pricing, an average price is calculated over a three-month period using the average monthly foreign exchange rate from USD to EUR (source: European Central Bank). Since not all facts are immediately available at the start of each month, a one-month buffer is allowed before the new average price applies.

Examples of calculation of the average official price:

Period for calculation of the average price:	Period during which the order/release order is effected and the average price applies:
Sep 2012 - Nov 2012	Q1 in 2013 (Jan - Mar)
Dec 2012 - Feb 2013	Q2 in 2013 (Apr - Jun)
Mar 2013 - May 2013	Q3 in 2013 (Jul - Sep)
Jun 2013 - Aug 2013	Q4 in 2013 (Oct - Dec)

Structure of the metal factor

The metal factor consists of several digits; the first digit is not relevant to the calculation of dysprosium and neodym.

The remaining digits indicate the method of calculation used for the respective raw material. If no surcharge is added for a raw material, a "-" is used.

1st digit	List or customer net price using the percentage method
2nd digit	for silver (AG) ¹⁾
3rd digit	for copper (CU) ¹⁾
4th digit	for aluminum (AL) ¹⁾
5th digit	for lead (PB) ¹⁾
6th digit	for gold (AU) ¹⁾
7th digit	for dysprosium (Dy)
8th digit	for neodym (Nd)

Weight method

The weight method uses the basic official price, the average price and the raw material weight. In order to calculate the surcharge, the basic official price must be subtracted from the average price. The difference is then multiplied by the raw material weight.

The basic official price can be found in the table below using the number (1 to 9) of the respective digit of the metal factor. Your Sales contact can inform you of the raw material weight.

Metal factor examples

-----71	No basis necessary
	No surcharge for silver
	No surcharge for copper
	No surcharge for aluminum
	No surcharge for lead
	No surcharge for gold
	Dysprosium acc. to weight, basic official price 300 €
	Neodym acc. to weight, basic official price 50 €

1) For a different method of calculation, refer to the separate explanation for these raw materials on the previous page.

2) Source: Asian Metal Ltd (www.asianmetal.com)

Appendix

Metal surcharges

Values of the metal factor

Percentage method	Basic official price in €	Step range in €	% surcharge 1st step	% surcharge 2nd step	% surcharge 3rd step	% surcharge 4th step	% surcharge per additional step	
			Price in € 150.01 - 200.00	Price in € 200.01 - 250.00	Price in € 250.01 - 300.00	Price in € 300.01 - 350.00		
A	150	50	0.1	0.2	0.3	0.4	0.1	
B	150	50	0.2	0.4	0.6	0.8	0.2	
C	150	50	0.3	0.6	0.9	1.2	0.3	
D	150	50	0.4	0.8	1.2	1.6	0.4	
E	150	50	0.5	1.0	1.5	2.0	0.5	
F	150	50	0.6	1.2	1.8	2.4	0.6	
G	150	50	1.0	2.0	3.0	4.0	1.0	
H	150	50	1.2	2.4	3.6	4.8	1.2	
I	150	50	1.6	3.2	4.8	6.4	1.6	
J	150	50	1.8	3.6	5.4	7.2	1.8	
			175.01 - 225.00	225.01 - 275.00	275.01 - 325.00	325.01 - 375.00		
O	175	50	0.1	0.2	0.3	0.4	0.1	
P	175	50	0.2	0.4	0.6	0.8	0.2	
R	175	50	0.5	1.0	1.5	2.0	0.5	
			225.01 - 275.00	275.01 - 325.00	325.01 - 375.00	375.01 - 425.00		
S	225	50	0.2	0.4	0.6	0.8	0.2	
U	225	50	1.0	2.0	3.0	4.0	1.0	
V	225	50	1.0	1.5	2.0	3.0	1.0	
W	225	50	1.2	2.5	3.5	4.5	1.0	
			150.01 - 175.00	175.01 - 200.00	200.01 - 225.00	225.01 - 250.00		
Y	150	25	0.3	0.6	0.9	1.2	0.3	
			400.01 - 425.00	425.01 - 450.00	450.01 - 475.00	475.01 - 500.00		
Z	400	25	0.1	0.2	0.3	0.4	0.1	
Price basis (1st digit)								
L	Calculation based on the list price							
N	Calculation based on the customer net price (discounted list price)							
Weight method	Basic official price in €							
1	50	Calculation based on raw material weight						
2	100							
3	150							
4	175							
5	200							
6	225							
7	300							
8	400							
9	555							
Miscellaneous								
-	No metal surcharge							

1. General Provisions

By using this catalog you can acquire hardware and software products described therein from Siemens AG subject to the following Terms and Conditions of Sale and Delivery (hereinafter referred to as "T&C"). Please note that the scope, the quality and the conditions for supplies and services, including software products, by any Siemens entity having a registered office outside Germany, shall be subject exclusively to the General Terms and Conditions of the respective Siemens entity. The following T&C apply exclusively for orders placed with Siemens Aktiengesellschaft, Germany.

1.1 For customers with a seat or registered office in Germany

For customers with a seat or registered office in Germany, the following applies subordinate to the T&C:

- for installation work the "General Conditions for Erection Works – Germany"¹⁾ ("Allgemeine Montagebedingungen – Deutschland" (only available in German at the moment)) and/or
- for Plant Analytics Services the "Standard Terms and Conditions for Plant Analytics Services – for Customer in Germany"¹⁾ ("Allgemeine Geschäftsbedingungen für das Plant Analytics Services – für Kunden in Deutschland" (only available in German at the moment)) and/or
- for stand-alone software products and software products forming a part of a product or project, the "General License Conditions for Software Products for Automation and Drives for Customers with a Seat or registered Office in Germany"¹⁾ and/or
- for other supplies and/or services the "General Conditions for the Supply of Products and Services of the Electrical and Electronics Industry"¹⁾.
In case such supplies and/or services should contain Open Source Software, the conditions of which shall prevail over the "General Conditions for the Supply of Products and Services of the Electrical and Electronics Industry"¹⁾. A notice will be contained in the scope of delivery in which the applicable conditions for Open Source Software are specified. This shall apply mutatis mutandis for notices referring to other third party software components.

1.2 For customers with a seat or registered office outside Germany

For customers with a seat or registered office outside Germany, the following applies subordinate to the T&C:

- for Plant Analytics Services the "Standard Terms and Conditions for Plant Analytics Services"¹⁾ and/or
- for services the "International Terms & Conditions for Services"¹⁾ supplemented by "Software Licensing Conditions"¹⁾ and/or
- for other supplies of hard- and/or software the "International Terms & Conditions for Products"¹⁾ supplemented by "Software Licensing Conditions"¹⁾.

1.3 For customers with master or framework agreement

To the extent our supplies and/or services offered are covered by an existing master or framework agreement, the terms and conditions of that agreement shall apply instead of T&C.

2. Prices

The prices are in € (Euro) ex point of delivery, exclusive of packaging.

The sales tax (value added tax) is not included in the prices. It shall be charged separately at the respective rate according to the applicable statutory legal regulations.

Prices are subject to change without prior notice. We will charge the prices valid at the time of delivery.

To compensate for variations in the price of raw materials (e.g. silver, copper, aluminum, lead, gold, dysprosium and neodym), surcharges are calculated on a daily basis using the so-called metal factor for products containing these raw materials. A surcharge for the respective raw material is calculated as a supplement to the price of a product if the basic official price of the raw material in question is exceeded.

The metal factor of a product indicates the basic official price (for those raw materials concerned) as of which the surcharges on the price of the product are applied, and with what method of calculation.

You will find a detailed explanation of the metal factor on the page headed "Metal surcharges".

To calculate the surcharge (except in the cases of dysprosium and neodym), the official price from the day prior to that on which the order was received or the release order was effected is used.

3. Additional Terms and Conditions

The dimensions are in mm. In Germany, according to the German law on units in measuring technology, data in inches apply only to devices for export.

Illustrations are not binding.

Insofar as there are no remarks on the individual pages of this catalog – especially with regard to data, dimensions and weights given – these are subject to change without prior notice.

¹⁾ The text of the Terms and Conditions of Siemens AG can be downloaded at www.siemens.com/automation/salesmaterial-as/catalog/en/terms_of_trade_en.pdf

Appendix

Conditions of sale and delivery

4. Export regulations

We shall not be obligated to fulfill any agreement if such fulfillment is prevented by any impediments arising out of national or international foreign trade or customs requirements or any embargoes and/or other sanctions.

Export may be subject to license. We shall indicate in the delivery details whether licenses are required under German, European and US export lists.

Our products are controlled by the U.S. Government (when labeled with "ECCN" unequal "N") and authorized for export only to the country of ultimate destination for use by the ultimate consignee or end-user(s) herein identified. They may not be resold, transferred, or otherwise disposed of, to any other country or to any person other than the authorized ultimate consignee or end-user(s), either in their original form or after being incorporated into other items, without first obtaining approval from the U.S. Government or as otherwise authorized by U.S. law and regulations.

The export indications can be viewed in advance in the description of the respective goods on the Industry Mall, our online catalog system. Only the export labels "AL" and "ECCN" indicated on order confirmations, delivery notes and invoices are authoritative.

Products labeled with "AL" unequal "N" are subject to European / national export authorization. Products without label, with label "AL:N" / "ECCN:N", or label "AL:9X9999" / "ECCN: 9X9999" may require authorization from responsible authorities depending on the final end-use, or the destination.

If you transfer goods (hardware and/or software and/or technology as well as corresponding documentation, regardless of the mode of provision) delivered by us or works and services (including all kinds of technical support) performed by us to a third party worldwide, you must comply with all applicable national and international (re-)export control regulations.

If required for the purpose of conducting export control checks, you (upon request by us) shall promptly provide us with all information pertaining to the particular end customer, final disposition and intended use of goods delivered by us respectively works and services provided by us, as well as to any export control restrictions existing in this relation.

The products listed in this catalog may be subject to European/German and/or US export regulations. Any export requiring approval is therefore subject to authorization by the relevant authorities.

Errors excepted and subject to change without prior notice.

Further information can be obtained from our branch offices listed at www.siemens.com/automation-contact

Interactive Catalog	<i>Catalog</i>	Process Instrumentation and Analytics	<i>Catalog</i>
Products for Automation and Drives	CA 01	<i>Digital: Field Instruments for Process Automation</i>	FI 01
Building Control		<i>Digital: Display Recorders SIREC D</i>	MP 20
GAMMA Building Control	ET G1	<i>Digital: SIPART Controllers and Software</i>	MP 31
Drive Systems		Products for Weighing Technology	WT 10
SINAMICS G130 Drive Converter Chassis Units	D 11	<i>Digital: Process Analytical Instruments</i>	AP 01
SINAMICS G150 Drive Converter Cabinet Units		<i>Digital: Process Analytics, Components for Continuous Emission Monitoring</i>	AP 11
<i>Digital: SINAMICS PERFECT HARMONY GH180 Medium-Voltage Air-Cooled Drives (Germany Edition)</i>	D 15.1	Low-Voltage Power Distribution and Electrical Installation Technology	
SINAMICS G180 Converters – Compact Units, Cabinet Systems, Cabinet Units Air-Cooled and Liquid-Cooled	D 18.1	SENTRON · SIVACON · ALPHA Protection, Switching, Measuring and Monitoring Devices, Switchboards and Distribution Systems	LV 10
SINAMICS S120 Chassis Format Converter Units	D 21.3	Electrical Components for the Railway Industry	LV 12
SINAMICS S120 Cabinet Modules		Power Monitoring Made Simple	LV 14
SINAMICS S150 Converter Cabinet Units		Components for Industrial Control Panels according to UL Standards	LV 16
SINAMICS S120 and SIMOTICS	D 21.4	<i>Digital: Air circuit breakers and molded case circuit breakers with UL certification</i>	LV 18
SINAMICS DCM DC Converter, Control Module	D 23.1	3WT Air Circuit Breakers up to 4000 A	LV 35
SINAMICS Inverters for Single-Axis Drives · Built-In Units	D 31.1	3VT Molded Case Circuit Breakers up to 1600 A	LV 36
SINAMICS Inverters for Single-Axis Drives · Distributed Inverters	D 31.2	<i>Digital: SIVACON System Cubicles, System Lighting and System Air-Conditioning</i>	LV 50
<i>Digital: SINAMICS Converters for Single-Axis Drives · SINAMICS G120X</i>	D 31.5	<i>Digital: ALPHA Distribution Systems</i>	LV 51
<i>Digital: SINAMICS S210 Servo Drive System</i>	D 32	ALPHA FIX Terminal Blocks	LV 52
<i>Digital: SINAMICS V90 Basic Servo Drive System</i>	D 33	SIVACON S4 Power Distribution Boards	LV 56
<i>Digital: SINAMICS G120P and SINAMICS G120P Cabinet pump, fan, compressor converters</i>	D 35	SIVACON 8PS Busbar Trunking Systems	LV 70
LOHER VARIO High Voltage Motors	D 83.2	<i>Digital: DELTA Switches and Socket Outlets</i>	ET D1
Flameproof, Type Series 1PS4, 1PS5, 1MV4 and 1MV5 Frame Size 355 to 1000, Power Range 80 to 7100 kW		Vacuum Switching Technology and Components for Medium Voltage	HG 11.01
<i>Digital: Three-Phase Induction Motors SIMOTICS HV, SIMOTICS TN</i>	D 84.1	Power Supply	
<i>Digital: Three-Phase Induction Motors SIMOTICS HV</i>	D 84.3	SITOP Power supply	KT 10.1
High Voltage Three-phase Induction Motors	D 84.9	Safety Integrated	
SIMOTICS HV Series A-compact PLUS		Safety Technology for Factory Automation	SI 10
<i>Digital: Modular Industrial Generators SIGENTICS M</i>	D 85.1	SIMATIC HMI / PC-based Automation	
Synchronous Motors with Permanent-Magnet Technology, HT-direct	D 86.2	Human Machine Interface Systems/ PC-based Automation	ST 80/ ST PC
DC Motors	DA 12	SIMATIC Ident	
SIMOVERT PM Modular Converter Systems	DA 45	Industrial Identification Systems	ID 10
MICROMASTER 420/430/440 Inverters	DA 51.2	SIMATIC Industrial Automation Systems	
MICROMASTER 411/COMBIMASTER 411	DA 51.3	Products for Totally Integrated Automation	ST 70
<u>Low-Voltage Three-Phase-Motors</u>		SIMATIC PCS 7 Process Control System	ST PCS 7
SIMOTOCS S-1FG1 Servo geared motors	D 41	System components	
SIMOTICS Low-Voltage Motors	D 81.1	SIMATIC PCS 7 Process Control System	ST PCS 7 T
SIMOTICS FD Low-Voltage Motors	D 81.8	Technology components	
LOHER Low-Voltage Motors	D 83.1	Add-ons for the SIMATIC PCS 7 Process Control System	ST PCS 7 AO
<i>Digital: MOTOX Geared Motors</i>	D 87.1	SIMATIC S7-400 advanced controller	ST 400
SIMOGEAR Geared Motors	MD 50.1	SIMATIC NET	
SIMOGEAR Electric-monorail geared motors	MD 50.8	Industrial Communication	IK PI
Light-load and heavy-load applications		SIRIUS Industrial Controls	
SIMOGEAR Gearboxes with adapter	MD 50.11	<i>Digital: SIRIUS Industrial Controls</i>	IC 10
<u>Mechanical Driving Machines</u>			
FLENDER Standard Couplings	MD 10.1		
FLENDER High Performance Couplings	MD 10.2		
FLENDER Backlash-free Couplings	MD 10.3		
FLENDER SIP Standard industrial planetary gear units	MD 31.1		
Motion Control			
SINUMERIK 840 Equipment for Machine Tools	NC 62		
SINUMERIK 808 Equipment for Machine Tools	NC 81.1		
SINUMERIK 828 Equipment for Machine Tools	NC 82		
SIMOTION Equipment for Production Machines	PM 21		
<i>Digital: Drive and Control Components for Cranes</i>	CR 1		

*Digital: These catalogs are only available as a PDF.***Information and Download Center**

Digital versions of the catalogs are available on the Internet at:
www.siemens.com/industry/infocenter
 There you'll find additional catalogs in other languages.

Get more information

SINAMICS G120XA infrastructure converters for standard pumps/fans:

www.siemens.com.cn/sinamics-g120xa

SIMOTICS electric motors:

www.siemens.com/simotics

Motion Control Systems and Solutions for production machine and machine tool equipment:

www.siemens.com/motioncontrol

Local partners worldwide:

www.siemens.com/automation-contact

Siemens AG
Digital Factory Division
Motion Control
Postfach 31 80
91050 ERLANGEN
GERMANY

© Siemens AG 2019
Subject to change without prior notice
(Article No. E86060-K5531-A161-A1-7600)
V6.MKKATA.GMC.108
KG 0119 84 En
Produced in Germany

The information provided in this catalog contains merely general descriptions or characteristics of performance which in case of actual use do not always apply as described or which may change as a result of further development of the products. An obligation to provide the respective characteristics shall only exist if expressly agreed in the terms of contract. Availability and technical specifications are subject to change without notice.

All product designations may be trademarks or product names of Siemens AG or supplier companies whose use by third parties for their own purposes could violate the rights of the owners.

Security information

Siemens provides products and solutions with industrial security functions that support the secure operation of plants, systems, machines and networks.

In order to protect plants, systems, machines and networks against cyber threats, it is necessary to implement – and continuously maintain – a holistic, state-of-the-art industrial security concept. Siemens' products and solutions constitute one element of such a concept.

Customers are responsible for preventing unauthorized access to their plants, systems, machines and networks. Such systems, machines and components should only be connected to an enterprise network or the internet if and to the extent such a connection is necessary and only when appropriate security measures (e.g. firewalls and/or network segmentation) are in place.

For additional information on industrial security measures that may be implemented, please visit

<https://www.siemens.com/industrialsecurity>

Siemens' products and solutions undergo continuous development to make them more secure. Siemens strongly recommends that product updates are applied as soon as they are available and that the latest product versions are used. Use of product versions that are no longer supported, and failure to apply the latest updates may increase customer's exposure to cyber threats.

To stay informed about product updates, subscribe to the Siemens Industrial Security RSS Feed under

<https://www.siemens.com/industrialsecurity>

Discover the
advantages of
Integrated Drive
Systems at a glance

