



Liebert®

DSE™ Thermal Management System

Installer/User Guide

Downflow 50 to 165 kW (14 to 47 ton) Capacity; Upflow 80 to 85 kW (23 to 24 ton)
Capacity, 50 and 60 Hz

The information contained in this document is subject to change without notice and may not be suitable for all applications. While every precaution has been taken to ensure the accuracy and completeness of this document, Vertiv assumes no responsibility and disclaims all liability for damages resulting from use of this information or for any errors or omissions. Refer to other local practices or building codes as applicable for the correct methods, tools, and materials to be used in performing procedures not specifically described in this document.

The products covered by this instruction manual are manufactured and/or sold by Vertiv. This document is the property of Vertiv and contains confidential and proprietary information owned by Vertiv. Any copying, use or disclosure of it without the written permission of Vertiv is strictly prohibited.

Names of companies and products are trademarks or registered trademarks of the respective companies. Any questions regarding usage of trademark names should be directed to the original manufacturer.

Technical Support Site

If you encounter any installation or operational issues with your product, check the pertinent section of this manual to see if the issue can be resolved by following outlined procedures. Visit <https://www.Vertiv.com/en-us/support/> for additional assistance.

TABLE OF CONTENTS

Important Safety Instructions	1
1 Nomenclature and Components	9
1.1 Liebert DSE Model-number Nomenclature	9
1.2 Component Location	11
2 Pre-installation Preparation and Guidelines	13
2.1 Planning Dimensions	14
2.2 Air-distribution Considerations for Downflow Units	14
2.3 Air-distribution Considerations for Upflow Units	16
2.4 Connections and System Setup	16
2.5 Operating Conditions	17
2.5.1 Cooling, Dehumidification and Humidification	17
2.5.2 Heating	19
2.5.3 Humidification Control	19
2.6 Shipping Dimensions and Unit Weights	19
3 Equipment Inspection and Handling	21
3.1 Packaging Material	22
3.2 Handling the Unit while Packaged	22
3.3 Unpacking the Unit	23
3.3.1 Removing the Unit from the Skid with a Forklift	23
3.3.2 Removing the Unit from the Skid Using Rigging	24
3.3.3 Moving the Unit to the Installation Location Using Piano Jacks	26
3.4 Placing the Unit on a Floor Stand	28
4 Piping and Refrigerant Requirements	29
4.1 Drain and Humidifier Fluid Piping	30
4.1.1 Field-installed, Gravity-fed Drain Line Requirements	31
4.1.2 Condensate-pump Drain Line Requirements	33
4.1.3 Water Supply-line Requirements for the Optional Humidifier	33
4.2 Refrigerant Piping and Charging	34
4.2.1 Refrigerant Piping Guidelines for Air-cooled Systems	35
4.2.2 Refrigerant Line Sizes and Equivalent Lengths	36
4.2.3 Refrigerant Charge Requirements for Air-cooled Systems	36
4.2.4 Additional Oil Requirements for Scroll and Digital-scroll Compressors	38
4.2.5 Evacuation, Leak-testing, and Charging Air-cooled Systems with Receivers	40
5 Electrical Connections	43
6 EC Fans and Plenums	45
6.1 Downflow Units with EC Fans	45
6.1.1 Lowering the EC Fans into the Floor Stand on Downflow Models	45
6.2 Downflow Unit Filter Plenums	48

6.3 Upflow-unit Plenums with EC Fans	51
6.3.1 Assembly Inspection	52
6.3.2 Assemble plenum rear and side panels	57
6.3.3 Wire the EC Fans	60
6.3.4 Install front panels on plenum	63
6.3.5 Assemble and Install compressor-section plenum	73
7 Checklist for Completed Installation	77
7.1 Moving and Placing Equipment	77
7.2 Electrical Installation Checks	77
7.3 Piping Installation Checks	77
7.4 Other Installation Checks	77
8 Initial Start-up Checks and Commissioning Procedure for Warranty Inspection	79
9 Maintenance	81
9.1 Filters	82
9.1.1 Filter-replacement for Downflow Units	82
9.1.2 Filter-replacement for Upflow Units	83
9.2 Blower Drive System—EC Fans	85
9.2.1 Protective Features	85
9.2.2 Fan Impellers and Bearings Maintenance	86
9.2.3 Fan Assembly Troubleshooting	86
9.2.4 Removing EC Fans from Downflow Units	90
9.2.5 Removing EC Fans from Upflow Units	94
9.3 Infrared Humidifier Maintenance	98
9.3.1 Cleaning Humidifier Pan and Float Switch	98
9.3.2 Changing Humidifier Lamps	99
9.4 Condensate-drain and Condensate-pump System Maintenance	100
9.4.1 Condensate Drain	100
9.4.2 Condensate Pump	100
9.5 Electric Reheat Maintenance	100
9.6 Electronic Expansion Valve (EEV) Maintenance	101
9.7 Compressor Maintenance	102
9.7.1 Compressor Oil	102
9.7.2 Replacement Compressors	102
9.7.3 Rotalock Valve on Digital-Scroll Compressors	103
9.7.4 Unloading Solenoid(s) on a Digital-scroll Compressor	103
9.7.5 Compressor Electrical Failure (Motor Burnout)	104
9.7.6 Replacing a Compressor with Electrical Failure (Motor Burnout)	104
9.7.7 Compressor Mechanical Failure	105
9.7.8 Replacing a Compressor with Mechanical Failure	105
9.8 Evaporator Coil Performance	105

9.9 Air-Cooled Condenser Maintenance	106
10 Preventive Maintenance Checklist	107
Appendices	113
Appendix A: Technical Support and Contacts	113
Appendix B: Disassembling the DSE for Transport	115
Appendix C: Submittal Drawings	127

This page intentionally left blank

IMPORTANT SAFETY INSTRUCTIONS

SAVE THESE INSTRUCTIONS

This manual contains important safety instructions that should be followed during the installation and maintenance of the Liebert® DSE. Read this manual thoroughly before attempting to install or operate this unit.

Only qualified personnel should move, install or service this equipment.

Adhere to all warnings, cautions, notices and installation, operating and safety instructions on the unit and in this manual. Follow all installation, operation and maintenance instructions and all applicable national and local building, electrical and plumbing codes.



WARNING! Arc flash and electric shock hazard. Open all local and remote electric power-supply disconnect switches, verify with a voltmeter that power is Off and wear appropriate, OSHA-approved personal protective equipment (PPE) per NFPA 70E before working within the electric control enclosure. Failure to comply can cause serious injury or death. Customer must provide earth ground to unit, per NEC, CEC and local codes, as applicable. Before proceeding with installation, read all instructions, verify that all the parts are included and check the nameplate to be sure the voltage matches available utility power. The Liebert® controller does not isolate power from the unit, even in the "Unit Off" mode. Some internal components require and receive power even during the "Unit Off" mode of the controller. The factory-supplied disconnect switch is inside the unit. The line side of this switch contains live high-voltage. The only way to ensure that there is NO voltage inside the unit is to install and open a remote disconnect switch. Refer to unit electrical schematic. Follow all local codes.



WARNING! Risk of electric shock. Can cause equipment damage, injury or death. Open all local and remote electric power supply disconnect switches and verify with a voltmeter that power is off before working within any electric connection enclosures. Service and maintenance work must be performed only by properly trained and qualified personnel and in accordance with applicable regulations and manufacturers' specifications. Opening or removing the covers to any equipment may expose personnel to lethal voltages within the unit even when it is apparently not operating and the input wiring is disconnected from the electrical source.



WARNING! Risk of electric shock. Can cause serious injury or death. The Liebert® iCOM microprocessor does not isolate power from the unit, even in the "Unit Off" mode. Some internal components require and receive power even during the "unit off" mode of the Liebert® iCOM control. Open all local and remote electric power disconnect switches and verify with a voltmeter that power is Off before working on any component of the system.



WARNING! Risk of electric shock. Can cause serious injury or death. Open all local and remote electric power supply disconnect switches and verify with a voltmeter that power is off before working within the fan-motor electric-connection enclosures. Fan-motor controls can maintain an electric charge for 10 minutes after power is disconnected. Wait 10 minutes after power is verified as off before working within the fan electric control/connection enclosures. Use only fully-trained and qualified HVAC technicians to perform maintenance on the fans.



WARNING! Risk of electric shock. Can cause injury or death. Open all local and remote electric power-supply disconnect switches and verify that power is Off with a voltmeter before working within the condensate pump electrical connection enclosure. The Liebert® iCOM™ does not isolate power from the unit, even in the “Unit Off” mode. Some internal components require and receive power even during the “Unit Off” mode of the Liebert® iCOM.



WARNING! Risk of electric shock. Can cause serious injury or death. The Liebert® iCOM microprocessor does not isolate power from the unit, even in the "Unit Off" mode. Some internal components require and receive power even during the "unit off" mode of the Liebert® iCOM control. Open all local and remote electric power disconnect switches and verify with a voltmeter that power is Off before working on any component of the system.



WARNING! Risk of over-pressurization of the refrigeration system. Can cause explosive discharge of high-pressure refrigerant, loss of refrigerant, environmental pollution, equipment damage, injury, or death. This unit contains fluids and gases under high pressure. Use extreme caution when charging the refrigerant system. Do not pressurize the system higher than the design pressure marked on the unit's nameplate. For systems requiring EU CE compliance (50 Hz), the system installer must provide and install a pressure relief valve in the high side refrigerant circuit that is rated same as the refrigerant high side “Max Allowable Pressure” rating that is marked on the unit serial tag. Do not install a shutoff valve between the compressor and the field installed relief valve. The pressure relief valve must be CE-certified to the EU Pressure Equipment Directive by an EU “Notified Body.”



WARNING! Risk of very heavy 125-lb (56.7-kg) fan modules dropping downward suddenly. Can cause injury or death.
Support fan modules before removing mounting hardware. Use caution to keep body parts out of the fan modules pathway during repositioning. Only properly trained and qualified personnel should work on this equipment.



WARNING! Risk of improper moving. Can cause equipment damage, injury or death. Use only lifting equipment that is rated for the unit weight by an OSHA-certified rating organization. The center of gravity varies depending on the unit size and selected options. The slings must be equally spaced on either side of the center of gravity indicator.
Shipping weights and unit weights are listed in the tables in [Shipping Dimensions and Unit Weights](#) on page 19.



WARNING! Risk of contact with high-speed rotating fan blades. Can cause serious injury or death. Open all local and remote electric power-supply disconnect switches, verify with a voltmeter that power is off, and verify that all fan blades have stopped rotating before working in the unit cabinet or on the fan assembly. If control voltage is applied, the fan motor can restart without warning after a power failure. Do not operate the unit with any or all cabinet panels removed.



WARNING! Risk of top-heavy unit falling over. Improper handling can cause equipment damage, injury or death. Read all of the following instructions and verify that all lifting and moving equipment is rated for the weight of the unit before attempting to move, lift, remove packaging from or prepare the unit for installation. Unit weights are specified in [Shipping Dimensions and Unit Weights](#) on page 19.



WARNING! Risk of improper wiring, piping, moving, lifting and handling. Can cause equipment damage, serious injury or death. Installation and service of this equipment should be done only by qualified personnel who have been specially-trained in the installation of air-conditioning equipment and who are wearing appropriate, OSHA-approved PPE.



WARNING! Risk of improper wire sizing/rating and loose electrical connections. Can cause overheated wire and electrical connection terminals resulting in smoke, fire, equipment and building damage, injury or death. Use correctly sized copper wire only and verify that all electrical connections are tight before turning power On. Check all electrical connections periodically and tighten as necessary.



WARNING! Risk of wiring damage, short circuits and electric shock. Can cause overheated wiring, smoke, fire, activation of fire suppression systems and EMS personnel and equipment, building and equipment damage, injury or death. Insert CSA certified or UL listed bushings into holes and or knockouts used to route wiring through metal panels to protect the wire insulation from contact with sheet metal edges.



WARNING! Risk of explosive discharge of high-pressure refrigerant. Can cause serious injury. Neutral and service ports on the rotalock valve do not have a valve core. Front-seat the service valves and relieve pressure from the compressor before loosening a part or a component attached to the service valve. Follow local codes to properly reclaim refrigerant.



CAUTION: Risk of excessive refrigerant line pressure. Can cause tubing and component rupture resulting in equipment damage and personal injury. Do not close off the refrigerant-line isolation valve for repairs unless a pressure-relief valve is field- installed in the line between the isolation valve and the check valve. The pressure-relief valve must be rated 5% to 10% higher than the system-design pressure. An increase in ambient temperature can cause the pressure of the isolated refrigerant to rise and exceed the system-design pressure rating (marked on the unit nameplate).



CAUTION: Risk of improper moving, lifting and handling. Can cause equipment damage or injury. Only properly trained and qualified personnel should work on this equipment. Evaporator fan modules weigh in excess of 125-lb (56.7-kg). Use proper lifting techniques and wear appropriate, OSHA-approved PPE to avoid injury and dropping the fan module during removal. Equipment used in handling/lifting, and/or installing the fan assembly must meet OSHA requirements. Use handling/lifting equipment rated for the weight of the fan assembly. Use ladders rated for the weight of the fan assembly and technicians if used during installation. Refer to handling/lifting, and/or installation equipment operating manual for manufacturer's safety requirements and operating procedures.



CAUTION: Risk of improper moving, lifting and handling. Can cause equipment damage or injury. Only properly trained and qualified personnel should work on this equipment. Condenser fan modules weigh in excess of 125-lb (56.7-kg). Use proper lifting techniques and wear appropriate, OSHA-approved PPE to avoid injury and dropping the fan module during removal. Equipment used in handling/lifting, and/or installing the fan assembly must meet OSHA requirements. Use handling/lifting equipment rated for the weight of the fan assembly. Use ladders rated for the weight of the fan assembly and technicians if used during installation. Refer to handling/lifting, and/or installation equipment operating manual for manufacturer's safety requirements and operating procedures.



CAUTION: Risk of contact with sharp edges, splinters, and exposed fasteners. Can cause injury. Only properly trained and qualified personnel wearing appropriate, OSHA-approved PPE should attempt to move, lift, remove packaging from or prepare the unit for installation.



CAUTION: Risk of contact with hot surfaces. Can cause injury. The electronics housing, humidifier components, compressor, refrigerant discharge lines, fan motor, and some electrical components are extremely hot during unit operation. Allow sufficient time for them to cool to a touch-safe temperature before working within the unit cabinet. Use extreme caution and wear appropriate, OSHA-approved PPE when working on or near hot components.



CAUTION: Risk of contact with extremely hot water and part surfaces. Can cause burn injury. The infrared humidifier bulbs, metal enclosure, humidifier water, water reservoir pan and drain tubing are very hot during and shortly after operation. Allow sufficient time for these parts to cool to a touch-safe temperature before handling. Use extreme caution, and wear appropriate, OSHA-approved PPE when performing maintenance on the infrared humidifier.



CAUTION: Risk of handling heavy and lengthy parts. Can cause personal injury and equipment damage. Cabinet panels can exceed 5 ft. (1.5 m) in length and weigh more than 35 lb. (15.9 kg). Follow relevant OSHA lifting recommendations and consider using a two-person lift for safe and comfortable removal and installation of cabinet panels. Only properly trained and qualified personnel wearing appropriate, OSHA-approved PPE should attempt to remove or install cabinet panels.



CAUTION: Risk of smoke generation. Can cause fire suppression and alarm system activation, resulting in injury during building evacuation and mobilization of emergency fire and rescue services. Start-up operation of optional electric reheat elements can create smoke or fumes that can activate the facility alarm and fire suppression system. Prepare and take appropriate steps to manage this possibility. Activating reheat during initial start-up may burn off particulates from electric reheat elements. Before beginning initial start-up checks, make certain that unit was installed according to the instructions in this manual. All exterior panels must be in place.



CAUTION: Risk of exposure to harmful noise levels. Can cause hearing injury or loss. Depending on the installation and operating conditions, a sound pressure level greater than 70 dB(A) may arise. Take appropriate technical safety measures. Operating personnel must wear appropriate, OSHA-approved PPE and observe all appropriate hearing-protection safety requirements.

NOTICE

Risk of improper power-supply connection. Can cause equipment damage and loss of warranty coverage.

Prior to connecting any equipment to a main or alternate power source (for example: back-up generator systems) for start-up, commissioning, testing, or normal operation, ensure that these sources are correctly adjusted to the nameplate voltage and frequency of all equipment to be connected. In general, power-source voltages should be stabilized and regulated to within $\pm 10\%$ of the load nameplate nominal voltage. Also, ensure that no three-phase sources are single-phased at any time.

NOTICE

Risk of oil contamination with water. Can cause equipment damage.

Liebert® DSE systems require the use of POE (polyolester) oil. POE oil absorbs water at a much faster rate when exposed to air than previously used oils. Because water is the enemy of a reliable refrigeration system, extreme care must be used when opening systems during installation or service. If water is absorbed into the POE oil, it will not be easily removed and will not be removed through the normal evacuation process. If the oil is too wet, it may require an oil change. POE oils also have a property that makes them act as a solvent in a refrigeration system. Maintaining system cleanliness is extremely important because the oil will tend to bring any foreign matter back to the compressor.

NOTICE

Risk of improper refrigerant charging. Can cause equipment damage.

Refrigerant charge must be weighed into air-cooled compressorized systems before they are started. Starting scroll and digital scroll compressors without proper refrigerant charging can cause the compressors to operate at less than 5°F (-15°C) evaporator temperature and at less than 52 psig (358 kPa). Operation for extended periods at less than 52 psig (358 kPa) can cause premature compressor failure.

NOTICE

Risk of clogged or leaking drain lines and leaking water-supply lines. Can cause equipment and building damage.

This unit requires a water drain connection. Drain lines must be inspected at start-up and periodically, and maintenance must be performed to ensure that drain water runs freely through the drain system and that lines are clear and free of obstructions and in good condition with no visible sign of damage or leaks. This unit may also require an external water supply to operate.

Improper installation, application and service practices can result in water leakage from the unit. Water leakage can result in catastrophic and expensive building and equipment damage and loss of critical data center equipment.

Do not locate unit directly above any equipment that could sustain water damage.

We recommend installing a monitored fluid-detection system to immediately discover and report coolant-fluid system and condensate drain-line leaks.

NOTICE

Risk of improper water supply. Can reduce humidifier efficiency or obstruct humidifier plumbing.

Do not use a hot water source. It will cause deposits that will eventually block the fill-valve opening.

NOTICE

Risk of water backing up in the drain line. Leaking and overflowing water can cause equipment and building damage.

Do not install an external trap in the drain line. This line already has a factory-installed trap inside the cabinet. Installation of a second trap will prevent drain-water flow and will cause the water to overflow the drain pan.

Sagging condensate drain lines may inadvertently create an external trap.

NOTICE

Risk of doorway/hallway interference. Can cause unit and/or structure damage. The unit may be too large to fit through a doorway or hallway while on the skid. Measure the unit and passageway dimensions, and refer to the installation plans prior to moving the unit to verify clearances.

NOTICE

Risk of damage from forklift. Can cause unit damage. Keep tines of the forklift level and at a height suitable to fit below the skid and/or unit to prevent exterior and/or underside damage.

NOTICE

Risk of improper storage. Can cause unit damage.

Keep the unit upright, indoors and protected from dampness, freezing temperatures and contact damage.

NOTE: The Liebert® indoor cooling unit has a factory-installed, high-pressure safety switch in the high-side refrigerant circuit. Each refrigerant receiver contains a fusible plug for fire-safety purposes. Consult your local building code to determine whether the refrigerant piping will require additional, field-provided pressure-relief devices.

NOTICE TO EUROPEAN UNION CUSTOMERS: DISPOSAL OF OLD APPLIANCES—This product uses components that are dangerous for the environment, such as electronic cards and other electronic components. Any component that is removed must be taken to specialized collection and disposal centers. If this unit must be dismantled, this must be done by a specialized center for collection and disposal of electric and electrical appliances or other dangerous substances.

This product has been supplied from an environmentally aware manufacturer that complies with the Waste Electrical and Electronic Equipment (WEEE) Directive 2012/19/CE.

The “crossed-out wheeled bin” symbol is placed on this product to encourage you to recycle wherever possible. Please be environmentally responsible and recycle this product through your recycling facility at its end of life. Do not dispose of this product as unsorted municipal waste. Follow local municipal waste ordinances for proper disposal provisions to reduce the environmental impact of waste electrical and electronic equipment (WEEE).

For information regarding the scrapping of this equipment, please browse www.Vertiv.com or call our worldwide technical support.

- Toll Free: 00 80011554499
- Toll Number Based in Italy: +39 0298250222

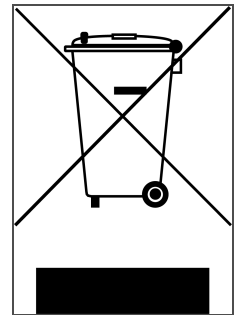

This page intentionally left blank

1 NOMENCLATURE AND COMPONENTS

This section describes the model number for Liebert® DSE units and components.

1.1 Liebert DSE Model-number Nomenclature

Table 1.2 below describes each digit of the model number.

Table 1.1 DSE Model Number Example

Model Number Digits 1 to 10										Model Details											Model Number Digits 11 to 14			
1	2	3	4	5	6	7	8	9	10	11	12	13	14	15	16	17	18	19	20	21	22	23	24	25
D	A	1	2	5	D	P	1	A	T	H	2	0	8	1	1	D	0	B	S	P	1	2	3	S

Table 1.2 DSE Model-number Digit Definitions

Digit	Description
Digits 1 and 2 = Product Family	DA = Liebert® DSE
Digit 3, 4, 5 = Nominal Cooling Capacity, kW	050 = 50 kW 080 = 80 kW 085 = 85 kW 125 = 125 kW 150 = 150 kW 165 = 165 kW
Digit 6 = Air Discharge	D = Downflow U = Upflow
Digit 7 = System Type	A = Air-cooled P = Air-cooled, Econ-O-Phase ready
Digit 8 = Air-flow (Fan Type)	1 = EC plug fans
Digit 9 = Voltage	A = 460 V - 3 ph - 60 Hz B = 575 V - 3 ph - 60 Hz C = 208 V - 3 ph - 60 Hz D = 230 V - 3 ph - 60 Hz 2 = 380 V - 3 ph - 60 Hz M = 380-415 V - 3 ph - 50 Hz

Table 1.2 DSE Model-number Digit Definitions (continued)

Digit	Description
Digit 10 = Cooling System	<p>D = Digital scroll, R-410A</p> <p>T = Tandem with digital scroll, R-410A</p>
Digit 11 = Humidifier	<p>0 = No humidifier</p> <p>H = Infrared Humidifier</p>
Digit 12 = Display	<p>2 = iCOM (High Definition)</p>
Digit 13 = Reheat	<p>0 = None</p> <p>1 = Electric reheat, standard capacity</p> <p>R = Electric reheat, reduced capacity</p>
Digit 14 = Air Filter	<p>8 = MERV 8, 4-in.</p> <p>9 = MERV 11, 4-in.</p> <p>A = MERV 13, 4-in.</p> <p>6 = MERV 11, 2-in. plus MERV 8 pre-filter, 2-in.</p> <p>C = MERV 13, 2-in. plus MERV 8 pre-filter, 2-in.</p>
Digit 15 = Coil Option	<p>1 = Non-coated coil, indoor unit</p>
Digit 16 = Enclosure Option	<p>1 = Color standard</p> <p>2 = Color optional</p> <p>3 = Color standard and IBC/OSHPD bracing</p> <p>4 = Color optional and IBC/OSHPD bracing</p>
Digit 17 = High-voltage option	<p>L = Locking disconnect</p> <p>5 = Locking disconnect, with condensate pump</p>
Digit 18 = Option packages	<p>0 = None</p> <p>L = Option package #1 - low-voltage terminal package</p> <p>H = Reheat and Humidifier lockout</p> <p>R = Remote humidity contact</p> <p>D = Option package #1 plus remote humidifier lockout</p> <p>E = Option package #1 plus reheat/humidifier lockout plus remote contact</p>

Table 1.2 DSE Model-number Digit Definitions (continued)

Digit	Description
Digit 19 = Monitoring	B = Base comms and connectivity
Digit 20 = Sensors	0 = None S = Smoke sensor H = High-temperature sensor F = Smoke and High-temperature sensors C = Compressor-overload sensors D = Compressor, smoke sensors K = Compressor, high-temperature, smoke sensors
Digit 21 = Packaging	P = Domestic C = Export
Digit 22-24 = Factory Configuration Number	
Digit 25 = Configuration Code	A = No SFAs (Any alpha letter except S) S = SFA

1.2 Component Location

The unit component locations are described in the submittal documents included in the [Submittal Drawings](#) on page 127.

The following table lists the relevant documents by number and title.

Table 1.3 Component-location Drawings

Document Number	Title
DPN003452	Component Location, Typical, Downflow Models, DA050 – DA165
DPN003451	Component Location, Typical, Upflow Models, DA080 – DA085

This page intentionally left blank

2 PRE-INSTALLATION PREPARATION AND GUIDELINES

NOTE: Before installing unit, determine whether any building alterations are required to run piping, wiring and duct work. Follow all unit dimensional drawings and refer to the submittal engineering dimensional drawings of individual units for proper clearances.

Refer to **Table 1.2** on page 9, and submittal drawings to determine the type of system being installed and anticipate building alterations, piping and duct work needed.

The unit dimensions, pipe-connection locations, and piping schematics are described in the submittal documents included in the [Submittal Drawings](#) on page 127.

- Verify that the floor is level, solid and sufficient to support the unit. See **2.6** on page 19 for unit weights.
- Confirm that the room is properly insulated and has a sealed vapor barrier.
- For proper humidity control, keep outside or fresh air to an absolute minimum (less than 5% of total air circulated in the room).
- Do not install a Liebert® DSE in an alcove or at the end of a long, narrow room.
- Install the units as close as possible to the largest heat load.
- Allow at least the minimum recommended clearances for maintenance and service. See the appropriate submittal drawings for dimensions.

We recommend installing an under-floor water detection system. Contact your Vertiv representative for information.

2.1 Planning Dimensions

The unit, floor stand, and plenum dimensions are described in the submittal documents included in the [Submittal Drawings](#) on page 127.

The following table lists the relevant documents by number and title.

Table 2.1 Dimension Planning Drawings

Document Number	Title
Downflow Units	
DPN003533	Cabinet Dimensional Data, DA050
DPN004083	Cabinet Dimensional Data, DA080 and DA085
DPN003175	Cabinet and Plenum Dimensional Data, DA125, DA150 and DA165
Upflow Units	
DPN002950	Cabinet Dimensional Data, DA080U and DA085U
Floor Stands	
DPN004079	Floorstand Dimensional Data, Downflow, DA050
DPN004073	Floorstand Dimensional Data, Downflow and Upflow, DA080 and DA085
DPN003177	Floorstand Dimensional Data, Downflow, DA125, DA150 and DA165
Plenums	
DPN003514	Plenum Dimensional Data, Downflow, DA050, DA080 and DA085
DPN004081	Plenum Dimensional Data, Upflow, DA080U and DA085U

2.2 Air-distribution Considerations for Downflow Units

- Verify that the raised floor has been properly sized for the unit's airflow and the room is free of airflow restrictions.
- Perforated floor tiles in the raised floor should ensure minimal pressure loss.
- The raised floor must provide 7-1/2 in. (191 mm) of clearance.
- A minimum of 24 in. (610 mm) is required to operate the fans when they are lowered with the factory-provided jacking mechanism.
- Ensure that there is adequate clearance above the unit for service, such as replacing filters.
- Optional plenums are available for downflow unit ducting.

Figure 2.1 Downflow unit field-installed ducting and plenum ducting for DA125, DA150 and DA165

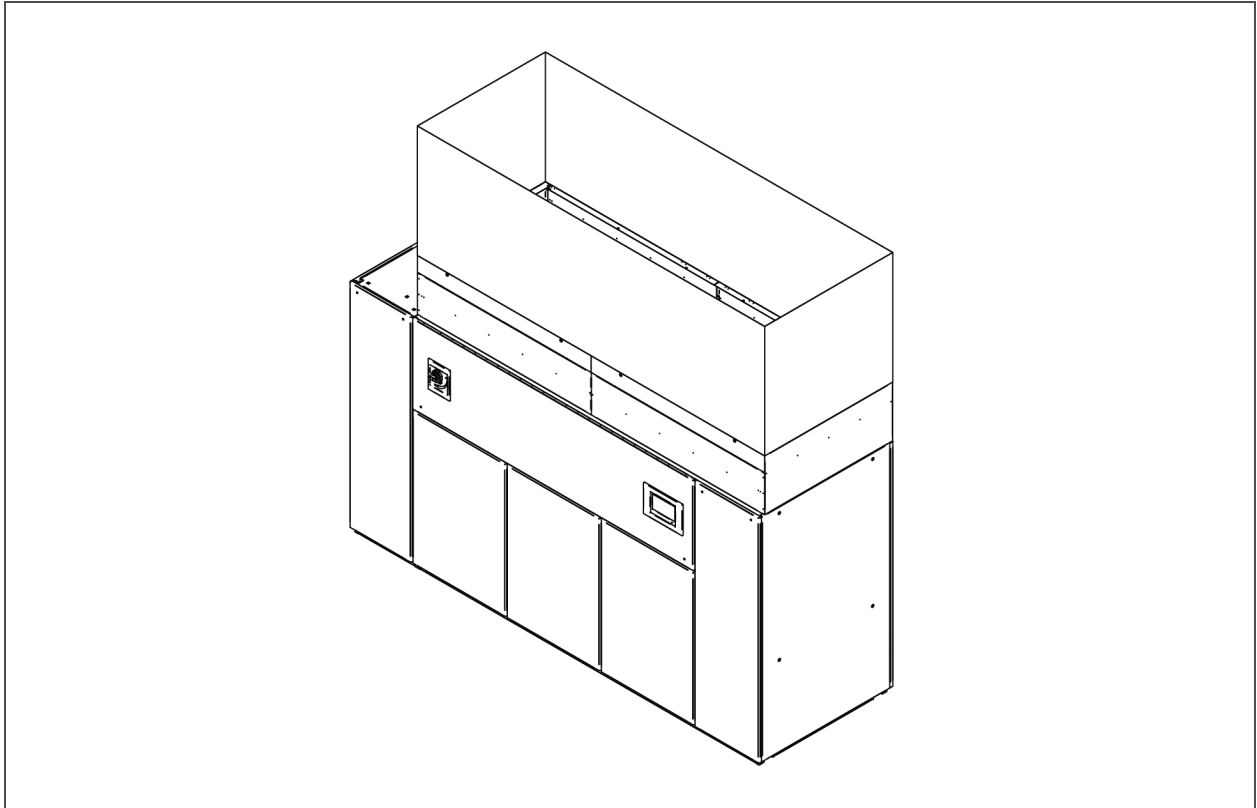

2.3 Air-distribution Considerations for Upflow Units

For in-room applications with supply and return grilles, several feet of clearance must be maintained at the intake and discharge of the unit.

NOTE: Drain traps are qualified to a return duct static of negative 1.5 i.w.g. (-1.5 i.w.g).

Figure 2.2 Upflow ducting configurations for EC fans for DA080 and DA085

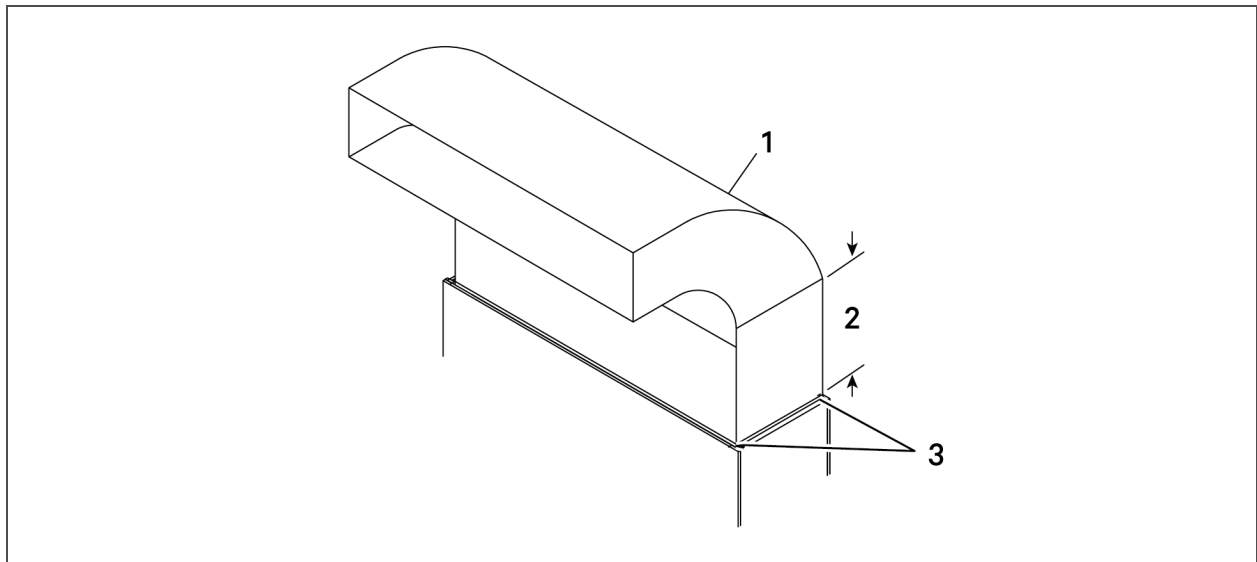

Item	Description
1	Typical ducting. May run to either side.
2	Straight section must be 2.5 times the depth of blower.
3	Ducting only attached to flanges on provided plenum.

NOTE: Follow standard practices in all duct work.

2.4 Connections and System Setup

- Three-phase electrical service is required for all models. Electrical service must conform to national and local electrical codes. See equipment nameplate for details.
- The unit requires a drain, which must comply with all applicable codes. See [Field-installed, Gravity-fed Drain Line Requirements](#) on page 31, for details.
- Plan the routing of wiring, piping and duct work to the unit. Refer to the appropriate piping connection location drawings, piping schematics, and electrical-connection drawings for your system in [Submittal Drawings](#) on page 127.
- If seismic requirements apply, consult your Vertiv representative for information about a seismic-rated floor stand.

NOTE: Seal openings around piping and electrical connection to prevent air leakage. Failure to do so could reduce the unit's cooling performance.

The DSE controls superheat with an electronic expansion valve (EEV). The EEV controller adjusts the orifice based on suction pressure and temperature. The EEV control will drive the valve to maintain the superheat setpoint, set in the Liebert® iCOM, using a Proportional, Integral, Derivative (PID) routine. The PID control values are set at the factory for most applications. These default values PID will allow stable superheat control of the unit.

For DA080/085 the default PID values must be updated to special PID values when the condenser is installed at the same level as the evaporator or +10 feet (3m) above the evaporator. The PID control values (both default and special) are noted **Table 2.2** below.

Table 2.2 EEV control values, default and special settings

Model #	EEV Settings	
	Default Values	Special Values (condenser and evaporator at same level ±10 ft [3 m])
DA050		E144 = MAN
		E160 = 0.6
		E161 = 250
		E162 = 1.0
DA080/085 Downflow Models	E144 = MAN	E144 = MAN
	E160 = 0.7	E160 = 1.5
	E161 = 250	E161 = 250
	E162 = 4.2	E162 = 2.5
DA080/085 Upflow Models		E144 = MAN
		E160 = 2.5
		E161 = 250
		E162 = 4.2
DA125/150 DA165		E144 = MAN
		E160 = 1.8
		E161 = 250
		E162 = 2.5

2.5 Operating Conditions

The Liebert® DSE must be operated in a conditioned space within the operating envelope that ASHRAE recommends for data centers. Operating the DSE outside of this envelope can decrease equipment reliability. Refer to ASHRAE’s publication, “Thermal Guidelines for Data Processing Environments.”

2.5.1 Cooling, Dehumidification and Humidification

The ASHRAE recommended maximum for return-air temperature is 105°F (40°C) and maximum dew point is 59°F (15°C). The recommended minimum return-air temperature setpoint for the DSE is 75°F (24°C).

Operating outside this envelope can decrease equipment reliability.

NOTE: If running in supply-air control, the minimum supply-air setpoint is 64°F (18°C).

DA050 Dehumidification Control

The DA050 is designed to maximize sensible cooling not latent cooling loads.

The room load must be at least 37.6 kW (74% of unit capacity) to prevent over cooling the room at 85°F (29°C) return air temperature while in dehumidification mode. If the room load is too low to maintain the setpoint, the compressor will cycle On and Off. For rooms with multiple units, we recommend performing dehumidification via Teamwork mode to prevent compressor cycling in case of lightly loaded rooms. Liebert® DSE units in dehumidification mode might not hold the temperature setpoint unless there is sufficient room load. This will allow for better dehumidification of the room. The DSE will allow the return air temperature to run down to 68°F (20°C) regardless of the temperature setpoint during dehumidification mode of operation.

DA080 and DA085 Dehumidification Control

The DA080 and DA085 will run at lower evaporator temperatures than a DA125. This will result in a higher percentage of latent cooling than with a DA125 at a given return air temperature. Dehumidification on DA080 and DA085 is possible with only one circuit running. In dehumidification mode, with one circuit running, a single stage 15-kW electric reheat (customer option) is available to help offset cooling for lightly loaded rooms, but over-cooling will be allowed down to 68°F (20°C). If the unit is running in dehumidification mode with both circuits (compressors) running, the electric reheat is not available to offset cooling. All DSE units allow the indoor blower to run at a reduced speed during dehumidification mode to increase the amount of dehumidification being performed.

DA125 Dehumidification Control

The DA125 is designed to maximize sensible cooling not latent cooling loads. With all four compressors running, no reheat will be available at this dehumidification load point (Stage 4).

The room load must be 94.1 kW (74% of unit capacity) to prevent over-cooling the room at 85°F (29°C) return air temperature. If the room load is too low to maintain the setpoint, the compressors will cycle On and Off. During Stage 3, with three of the four compressors running, 10 kW of reheat will be available to offset cooling. During Stage 1 and 2, with one and two compressors running respectively, 30 kW of reheat is available to offset cooling. For rooms with multiple units, We recommend performing dehumidification in Teamwork mode to prevent compressor cycling in case of lightly loaded rooms or by having standard DSE units available to perform dehumidification. DSE units in dehumidification mode might not hold the temperature setpoint unless there is sufficient room load. This will allow for better dehumidification of the room. The DSE will allow the return air temperature to run down to 68°F (20°C) regardless of the temperature setpoint during dehumidification mode of operation.

DA150 and DA165 Dehumidification Control

The DA150 and DA165 are designed to maximize sensible cooling not latent cooling loads. With all four compressors running, no reheat will be available at this dehumidification load point (Stage 4).

The room load must be 94.1 kW (74% of unit capacity) to prevent over-cooling the room at 85°F (29°C) return air temperature. If the room load is too low to maintain the setpoint, the compressors will cycle On and Off. During Stage 3, with three of the four compressors running, 10 kW of reheat will be available to offset cooling. During Stage 1 and 2, with one and two compressors running respectively, 30 kW of reheat is available to offset cooling. For rooms with multiple units, We recommend performing dehumidification via Teamwork mode to prevent compressor cycling in case of lightly loaded rooms. DSE units in dehumidification mode might not hold the temperature setpoint unless there is sufficient room load. This will allow for better dehumidification of the room. The DSE will allow the return air temperature to run down to 68°F (20°C) regardless of the temperature setpoint during dehumidification mode of operation.

2.5.2 Heating

The Liebert® DSE is qualified for heating-only operation at temperatures not exceeding 80°F (27°C).

2.5.3 Humidification Control

To prevent the humidifier from running when not required (especially when return air temperatures exceed 75°F [24°C]), the default control for humidity and dehumidification is based on dew point temperature, not relative humidity. If this default control is changed, adjust the relative humidity setpoint based on return air temperature to prevent from over-humidifying the space.

2.6 Shipping Dimensions and Unit Weights

Table 2.3 Downflow unit domestic and export shipping dimensions and weights

Model #	Domestic Packaging		Export Packaging		Dry Weight, lb (kg)
	Unit Ship Weight, lb (kg)	Shipping Dimensions, in. (mm)	Ship Weight, lb (kg)	Shipping Dimensions, in. (mm)	
DA050*A DA050*P	2012 (913)	97 X 45 X 82 (2464 X 1143 X 2083)	2182 (990)	97 X 45 X 82 (2464 X 1143 X 2083)	1590 (721)
DA080*A DA080*P	2250 (1021)	120 X 45 X 85 (3048 X 1143 X 2159)	2450 (1111)	120 X 45 X 85.5 (3048 X 1143 X 2172)	2200 (998)
DA085*A DA085*P	2350 (1066)	120 X 45 X 85 (3048 X 1143 X 2159)	2550 (1157)	120 X 45 X 85.5 (3048 X 1143 X 2172)	2250 (1021)
DA125*A DA125*P	3450 (1565)	153 X 54 X 85 (3886 X 1372 X 2159)	3650 (1656)	153.5 X 54.5 X 85.5 (3899 X 1384 X 2172)	3465 (1572)
DA150*A DA150*P	3570 (1619)	153 X 54 X 85 (3886 X 1372 X 2159)	3770 (1710)	153.5 X 54.5 X 85.5 (3899 X 1384 X 2172)	3574 (1621)
DA165*A DA165*P	3754 (1703)	153 X 54 X 85 (3886 X 1372 X 2159)	3954 (1794)	153.5 X 54.5 X 83.5 (3899 X 1384 X 2121)	3574 (1621)

Table 2.4 Upflow unit domestic and export shipping dimensions and weights

Model #	Domestic Packaging		Export Packaging		Dry Weight, lb (kg)
	Unit Ship Weight, lb (kg)	Shipping dimensions, in. (mm)	Ship Weight, lb (kg)	Shipping dimensions, in. (mm)	
DA080U*A DA080U*P	2270 (1030)	120 X 45 X 85 (3048 X 1143 X 2159)	2470 (1120)	120 X 45 X 85.5 (3048 X 1143 X 2172)	2150 (975)
DA085U*A DA085U*P	2370 (1075)	120 X 45 X 85 (3048 X 1143 X 2159)	2570 (1166)	120 X 45 X 85.5 (3048 X 1143 X 2172)	2150 (975)

This page intentionally left blank

3 EQUIPMENT INSPECTION AND HANDLING

SAFETY INFORMATION



WARNING! Risk of top-heavy unit falling over. Improper handling can cause equipment damage, injury or death. Read all of the following instructions and verify that all lifting and moving equipment is rated for the weight of the unit before attempting to move, lift, remove packaging from or prepare the unit for installation. Unit weights are specified in [Shipping Dimensions and Unit Weights](#) on page 19.



WARNING! Risk of improper moving. Can cause equipment damage, injury or death. Use only lifting equipment that is rated for the unit weight by an OSHA-certified rating organization. The center of gravity varies depending on the unit size and selected options. The slings must be equally spaced on either side of the center of gravity indicator.

Shipping weights and unit weights are listed in the tables in [Shipping Dimensions and Unit Weights](#) on page 19. Use the center of gravity indicators on the unit to determine the position of the slings.



CAUTION: Risk of contact with sharp edges, splinters, and exposed fasteners. Can cause injury. Only properly trained and qualified personnel wearing appropriate, OSHA-approved PPE should attempt to move, lift, remove packaging from or prepare the unit for installation.

NOTICE

Risk of passageway interference. Can cause unit and/or structure damage. The unit may be too large to fit through a passageway while on or off the skid. Measure the unit and passageway dimensions, and refer to the installation plans prior to moving the unit to verify clearances.

NOTICE

Risk of damage from forklift. Can cause unit damage. Keep tines of the forklift level and at a height suitable to fit below the skid and/or unit to prevent exterior and/or underside damage.

NOTICE

Risk of improper storage. Keep the unit upright, indoors and protected from dampness, freezing temperatures and contact damage.

Upon arrival of the unit and before unpacking:

- Verify that the labeled equipment matches the bill of lading.
- Carefully inspect all items for visible or concealed damage.
- Report damage immediately to the carrier and file a damage claim with a copy sent to Vertiv or to your sales representative.

Equipment Recommended for Handling the Unit:

- Forklift
- Pallet jack
- Piano jacks
- Lift beam
- Slings
- Spreader bars

3.1 Packaging Material



All material used to package this unit is recyclable. Please save for future use or dispose of the material appropriately.

3.2 Handling the Unit while Packaged

If possible, transport the unit with a forklift or pallet jack. If that is not possible, use a crane with slings and spreader bars that are rated for the weight of the unit.

When using a forklift or pallet jack:

- Ensure that the fork length is suitable for the unit length and, if adjustable, spread to the widest allowable distance that will fit under the skid.
- When moving the packaged unit, lift the unit from the "HEAVY SIDE" of the unit, and do not lift the unit any higher than 6 in. (152 mm). All personnel except those moving the unit must be kept or more from the unit while it is being moved.
- If the unit must be lifted higher than 6 in. (152 mm), all personnel not directly involved in moving the unit must be 20 ft (5 m) or farther from the unit.
- Always refer to the location of the center-of-gravity indicators when lifting the unit, see **Figure 3.1** below.

Figure 3.1 Center-of-gravity indicator



3.3 Unpacking the Unit

1. Remove the exterior stretch wrap packaging and two V-shaped boards from around the unit, as shown in **Figure 3.2** below.

NOTE: The bag may remain in place to protect from dust and to protect the unit panels, or it may be removed for immediate installation.

2. Remove the bag from the unit when ready to remove the skid and install the unit.

Figure 3.2 Unpacking the Unit

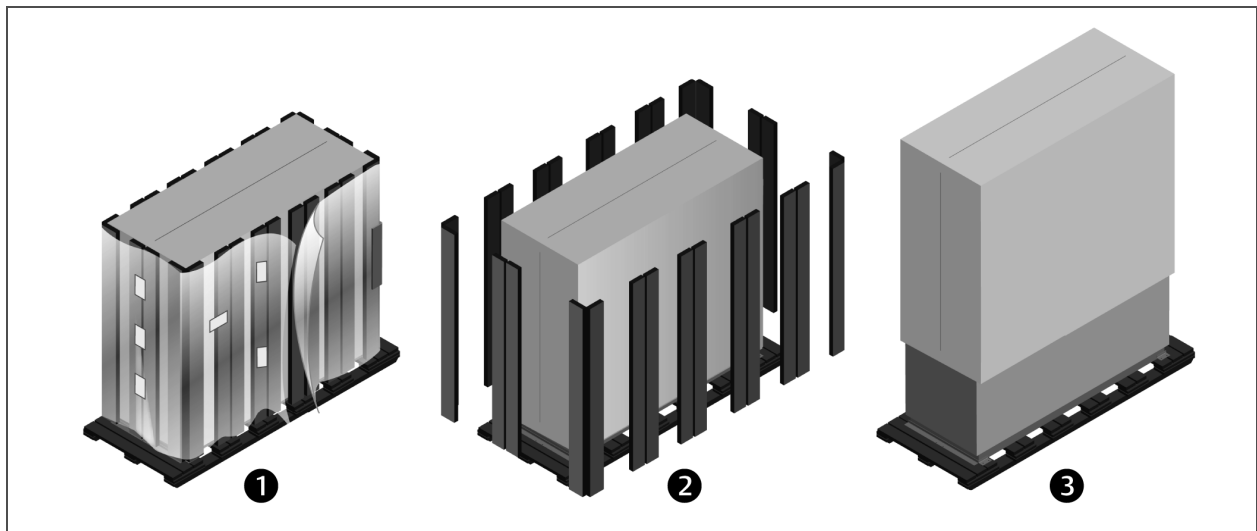

Item	Description
1	Remove exterior wrap from unit
2	Remove corner and side packaging planks
3	Leave the bag on the unit until ready to install.

3.3.1 Removing the Unit from the Skid with a Forklift

Refer to **Figure 3.3** on the next page.

1. Align a forklift with either the front or rear side of the unit.
 - Ensure that the tines of the fork lift are locked to the widest location.
 - Use the center of gravity indicators on the unit panels when determining the entry points for the tines. Center of gravity varies per unit size and selected options.
 - The tines shall be equally spaced on either side of the center of gravity indicator.
2. Insert the tines of the forklift completely under the base of the unit.
 - Ensure that the tines are level, not angled in an upward direction.
 - The tines are to be at a height that will allow proper clearance under the unit.
 - Ensure that the tines extend beyond the opposite side of the unit.

NOTE: If these steps are not followed, damage may occur to the panels and/or base of the unit.

3. Remove the lag bolts from each bracket located around the base, and remove the brackets.
4. Lift the unit off the skid to an elevation point where the skid is not supporting the weight of the unit and remove the skid from under the unit.

Figure 3.3 Removing from skid with a forklift

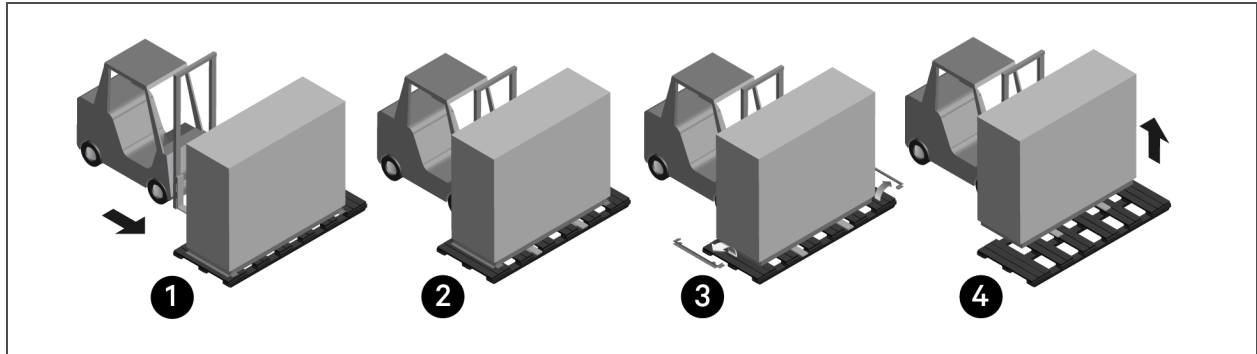

Item	Description
1	Align forklift with front or rear of unit.
2	Insert tines completely under base of unit.
3	Remove lag bolts and brackets
4	Lift unit and remove skid.

3.3.2 Removing the Unit from the Skid Using Rigging

1. Use the center-of-gravity indicators on the unit panels to determine the position of the slings.
 - The slings shall be equally-spaced on either side of the center-of-gravity indicator
2. Place the slings and between the bottom rails of the unit and the skid as shown in **Figure 3.4** on the facing page.

NOTE: Unit is shown without packaging. These instructions may be followed with or without the outer packaging in place.

Figure 3.4 Example sling placement

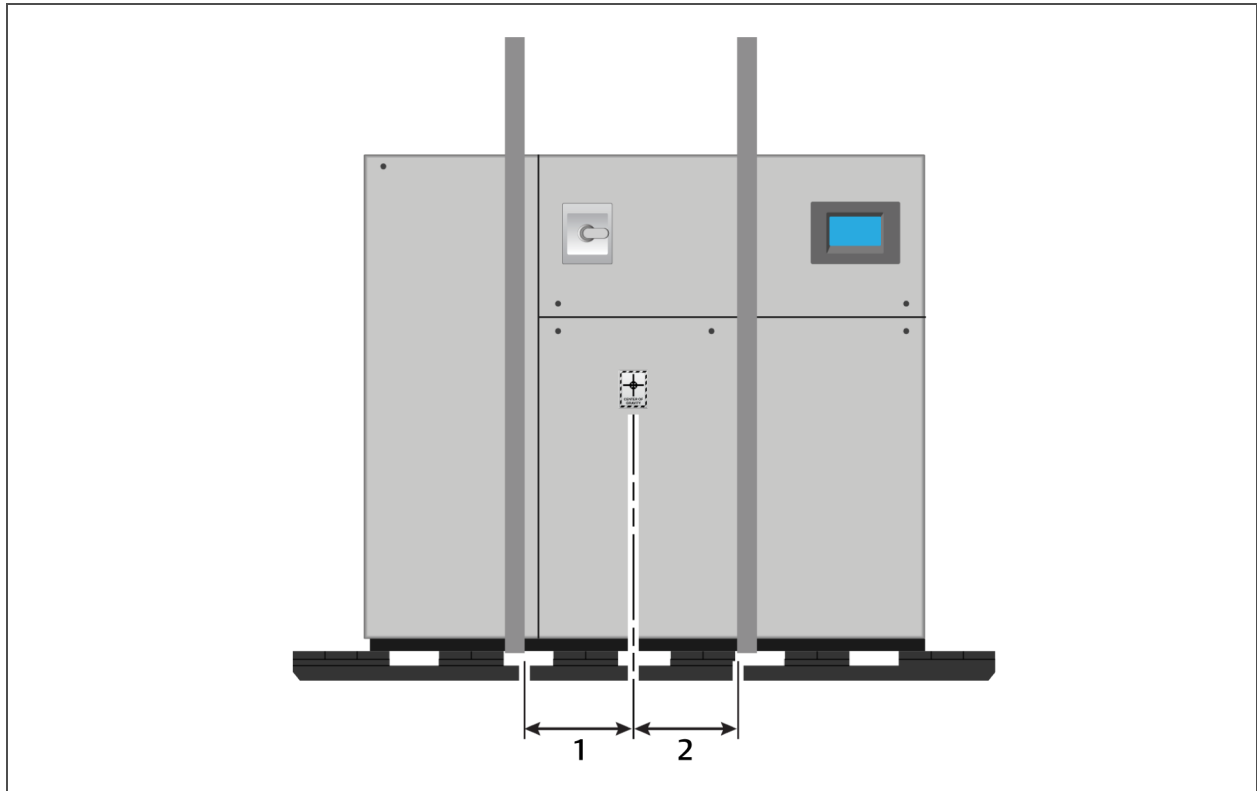

Item	Description
1	Distance between sling and center-of-gravity marker equal to item 2.
2	Distance between sling and center-of-gravity marker equal to item 1.

3. Referring to **Figure 3.5** below:

- Align the slings as described previously.
- Use spreader bars or equivalent device to ensure proper protection of the unit (Item 1).
- Remove the lag bolts from each bracket located around the base, and remove the brackets (Item 2).

NOTE: Depending on final installation location, the skid may need to remain under the unit. Therefore, the lag bolts and brackets would not yet be removed.

- Lift the unit off the skid to an elevation point where the skid is not supporting the weight of the unit and remove the skid from under the unit (Item 3).

Figure 3.5 Moving unit with rigging

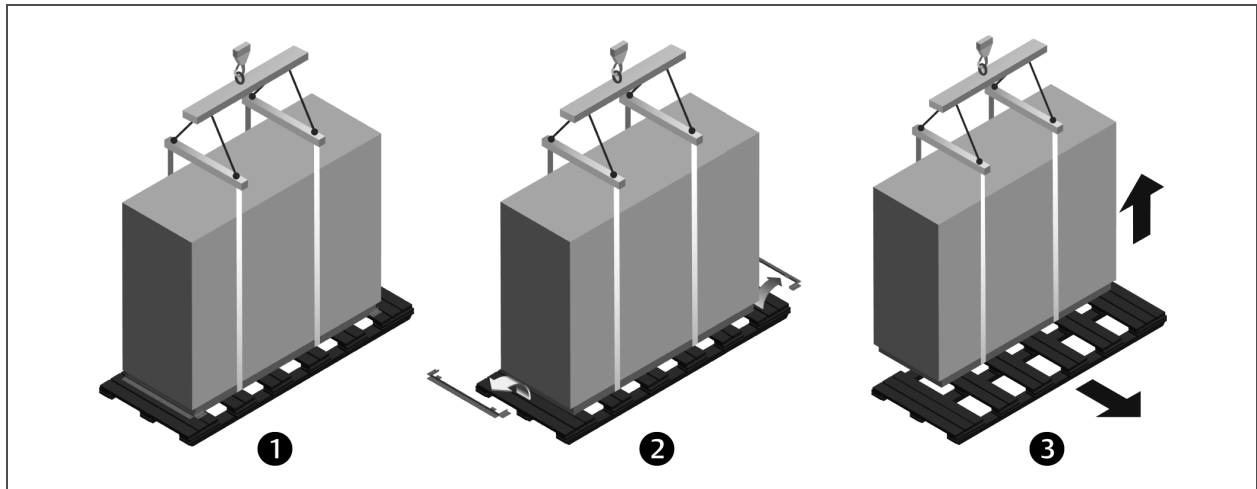

Item	Description
1	Spreader bars and rigging on unit.
2	Remove lag bolts and brackets.
3	Lift the unit and remove the skid.

3.3.3 Moving the Unit to the Installation Location Using Piano Jacks

Refer to **Figure 3.6** on the facing page.

1. With the unit elevated, position piano jacks at each end of the unit.
2. Lower the unit to a height suitable for the piano jacks, place protective material between the unit and the piano jacks and straps.

3. With the unit secured to the piano jacks, move the forklift away from the unit.
4. Using the piano jacks, at least two trained personnel can move the unit to the site for installation.
 - For location considerations, refer to [Pre-installation Preparation and Guidelines](#) on page 13.

Figure 3.6 Moving unit with piano jacks

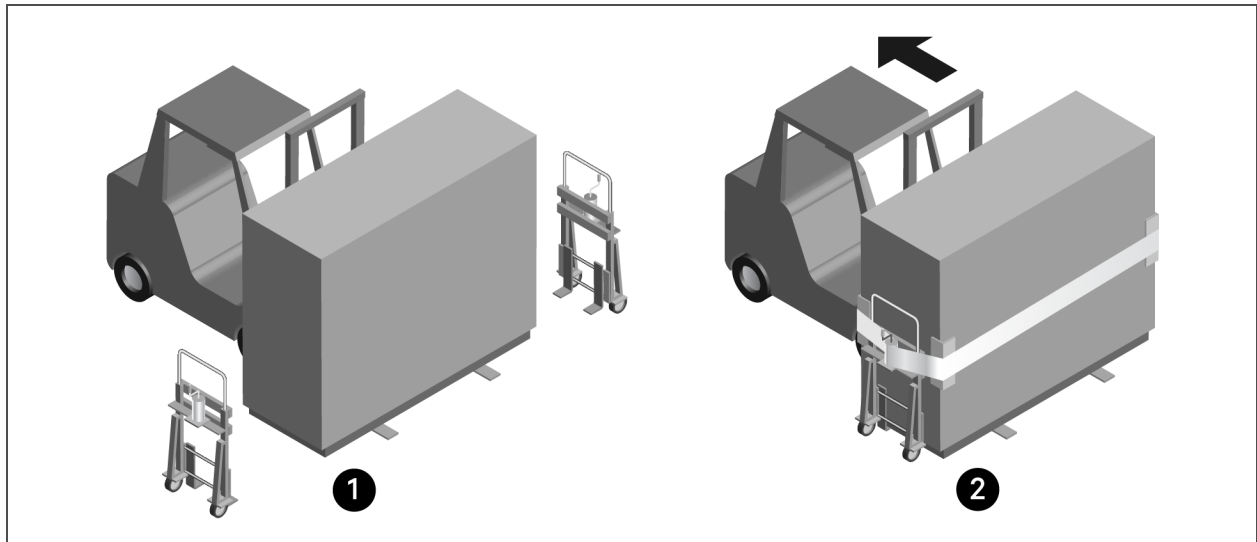

Item	Description
1	Place piano jacks on each end of the unit.
2	Use padding between unit and straps and, with the unit secured to the piano jacks, move the forklift away from the unit.

3.4 Placing the Unit on a Floor Stand

Refer to the floor-stand installation sheet, located inside the floor-stand package. Lower the unit onto the floor stand. Refer to **Figure 3.7** below. Be sure to align the welded tabs on top of the floor stand with the inside of the unit frame base.

NOTE: The floor stand for the units equipped with EC fans is not symmetrical. Its orientation to the unit is critical for lowering the EC fans. Unless the floor stand is installed in the correct position, the fans will not lower into the floor stand.

Figure 3.7 Welded tabs on floor stand

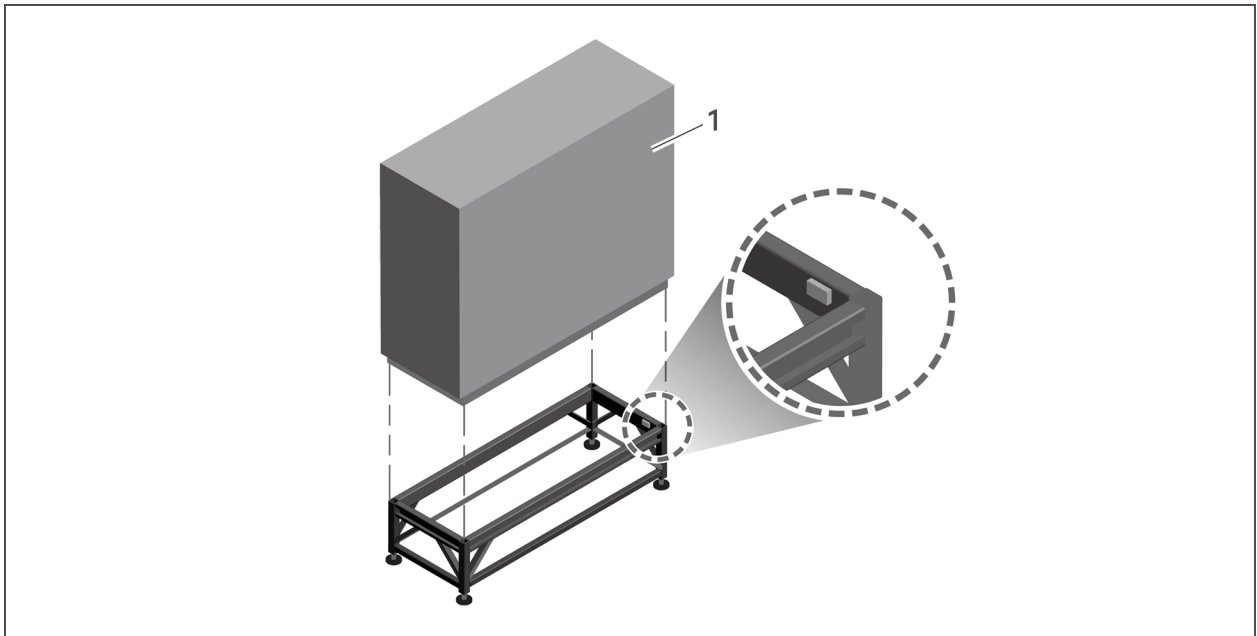

Item	Description
1	Front of unit

4 PIPING AND REFRIGERANT REQUIREMENTS

All fluid and refrigeration connections to the unit, with the exception of the condensate drain, are sweat copper. Factory-installed piping brackets must not be removed. Field-installed piping must be installed in accordance with local codes and must be properly assembled, supported, isolated and insulated. Avoid piping runs through noise-sensitive areas, such as office walls and conference rooms.

Refer to specific text and detailed diagrams in this manual for other unit-specific piping requirements.

All piping below the elevated floor must be located so that it offers the least resistance to air flow. Careful planning of the piping layout under the raised floor is required to prevent the air flow from being blocked. When installing piping on the subfloor, we recommend that the pipes be mounted in a horizontal plane rather than stacked one above the other. Whenever possible, the pipes should be run parallel to the air flow.

The following pipe connections are required:

- A drain line from the unit.
- A drain line from the secondary drain pan (if applicable).
- A water-supply line to the optional humidifier (if applicable).
- Refrigerant piping connections between the evaporator unit, the condensing unit, and the optional economizer unit. See [Refrigerant Piping and Charging](#) on page 34.

The pipe connection locations, piping general arrangement and schematics are described in the submittal documents included in the [Submittal Drawings](#) on page 127.

The following tables list the relevant documents by number and title.

Table 4.1 Piping General-arrangement Drawings

Document Number	Title
DPN002615	Piping Schematic, DA050, DA080 and DA085 with MC Condenser
DPN002340	Piping Schematic, DA125, DA150 and DA165 with MC Condenser
DPN004476	Piping Schematic, DA125, DA150 and DA165 with MCV Condenser
Liebert® MC Condenser and EconoPhase Pump Locations	
DPN003994	Considerations for mounting MC Condenser/EconoPhase Above or at Same Level as DSE
DPN003552	Typical arrangement for single-circuit system
DPN002324	Typical arrangement for dual-circuit system

Table 4.2 Piping Connection Drawings

Document Number	Title
Downflow Units	
DPN003531	Connection Locations, DA050
DPN004080	Connection Locations, DA080 and DA085
DPN002312	Connection Locations, DA125
DPN004037	Connection Locations, DA150 and DA165
Upflow Units	
DPN002951	Connection Locations, DA080U and DA085U

4.1 Drain and Humidifier Fluid Piping

NOTICE

Risk of water leakage. Can cause severe property damage and loss of critical data center equipment.

The Liebert® DSE requires a water drain connection. Improper installation, application and service practices can result in water leakage from the unit.

Do not locate the unit directly above any equipment that could sustain water damage.

We recommend installing monitored leak detection equipment for the water supply lines and the internal unit water lines.

4.1.1 Field-installed, Gravity-fed Drain Line Requirements

NOTICE

Risk of water backing up in the drain line. Leaking and overflowing water can cause equipment and building damage.

Do not install an external trap in the drain line. This line already has a factory-installed trap inside the cabinet. Installation of a second trap will prevent drain-water flow and will cause the water to overflow the drain pan.

Sagging condensate drain lines may inadvertently create an external trap.

A 3/4-in. NPT-Female drain connection is provided on DA050 to DA085 units without an optional condensate pump. A 1-1/8 in. NPT-Female drain connection is provided on DA125 to DA165 units without an optional condensate pump.

Observe the following requirements and refer to **Figure 4.1** on the next page, when installing and routing the drain line:

- The drain line must be sized for 2 gpm (7.6 l/m) flow.
- The drain line must be located so it will not be exposed to freezing temperatures.
- The drain should be the full size of the drain connection.
- The drain line must slope continuously away from the unit. Pitch drain line toward drain a minimum of 1/8 in. (3 mm) per 1 ft (305 mm) of length.
- Drain is trapped internally. Do not externally-trap the drain line.
- The drain line must be rigid enough that it does not sag between supports, which unintentionally creates traps.
- The drain line must comply with all applicable codes.
- On units with the optional, factory-installed condensate pump, see [Factory-installed Condensate Pump](#) on page 33 and [Condensate-pump Drain Line Requirements](#) on page 33.

Figure 4.1 Correct and Incorrect gravity drains for downflow and upflow units

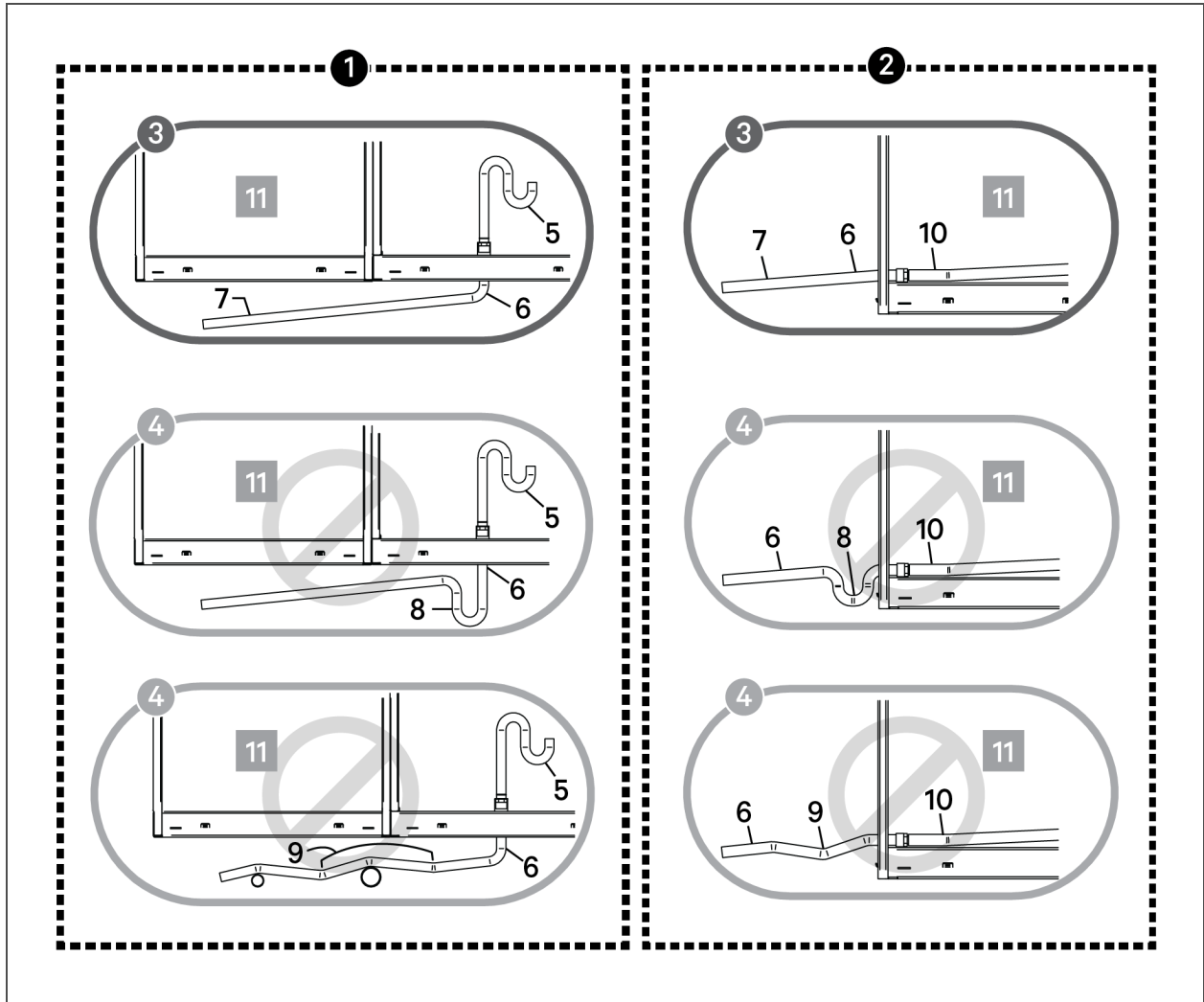

Table 4.3 Gravity-fed Drain Line Figure Descriptions

Item	Description
1	For downflow units
2	For upflow units
3	Correct drain installation
4	Incorrect drain installation
5	Internal drain
6	External drain
7	Continuous downward slope

Table 4.3 Gravity-fed Drain Line Figure Descriptions (continued)

Item	Description
8	External trap. Do not trap externally.
9	External traps, although unintentional. Lines must be rigid enough not to bow over top of other objects.
10	Internal drain
11	DSE unit

4.1.2 Condensate-pump Drain Line Requirements

NOTICE

Risk of water backing up in the drain line. Leaking and overflowing water can cause equipment and building damage.

Do not install an external trap in the drain line. This line already has a factory-installed trap inside the cabinet. Installation of a second trap will prevent drain-water flow and will cause the water to overflow the drain pan.

Sagging condensate drain lines may inadvertently create an external trap.

Observe the following requirements when installing and routing the drain line:

- The drain line must be located so it will not be exposed to freezing temperatures.
- Size the piping based on the available condensate head.
- Drain is trapped internally. Do not externally-trap the drain line.
- The drain line must be rigid enough that it does not sag between supports, which unintentionally creates traps.
- We recommend installing monitored, under-floor leak-detection equipment.

Factory-installed Condensate Pump

If your unit includes an optional condensate pump, the pump is factory-installed inside the unit and a 1/2-in. copper sweat connection is provided on the unit.

4.1.3 Water Supply-line Requirements for the Optional Humidifier

The unit may have an optional humidifier. Refer to the appropriate supply-line piping requirements if a humidifier is included on your unit:

Infrared Humidifier:

- 1/4-in. supply line, maximum water pressure is 150 psi (1034 kPa).
- Size supply line for 1 gpm (3.8 l/m), with a minimum water pressure of 20 psi (138 kPa).
- Do not supply de-ionized water to the humidifier.

4.2 Refrigerant Piping and Charging



WARNING! Risk of over-pressurization of the refrigeration system. Can cause explosive discharge of high-pressure refrigerant, loss of refrigerant, environmental pollution, equipment damage, injury, or death. This unit contains fluids and gases under high pressure. Use extreme caution when charging the refrigerant system. Do not pressurize the system higher than the design pressure marked on the unit's nameplate. For systems requiring EU CE compliance (50 Hz), the system installer must provide and install a pressure relief valve in the high side refrigerant circuit that is rated same as the refrigerant high side “Max Allowable Pressure” rating that is marked on the unit serial tag. Do not install a shutoff valve between the compressor and the field installed relief valve. The pressure relief valve must be CE-certified to the EU Pressure Equipment Directive by an EU “Notified Body.”



CAUTION: Risk of excessive refrigerant line pressure. Can cause tubing and component rupture resulting in equipment damage and personal injury. Do not close off the refrigerant-line isolation valve for repairs unless a pressure-relief valve is field-installed in the line between the isolation valve and the check valve. The pressure-relief valve must be rated 5% to 10% higher than the system-design pressure. An increase in ambient temperature can cause the pressure of the isolated refrigerant to rise and exceed the system-design pressure rating (marked on the unit nameplate).

Consult local building and plumbing codes for installation requirements of additional pressure-relief devices when isolation valves are field installed. Do not isolate any refrigerant circuits from over-pressurization protection.

NOTICE

Risk of oil contamination with water. Can cause equipment damage.

Liebert® DSE systems require the use of POE (polyolester) oil. POE oil absorbs water at a much faster rate when exposed to air than previously used oils. Because water is the enemy of a reliable refrigeration system, extreme care must be used when opening systems during installation or service. If water is absorbed into the POE oil, it will not be easily removed and will not be removed through the normal evacuation process. If the oil is too wet, it may require an oil change. POE oils also have a property that makes them act as a solvent in a refrigeration system. Maintaining system cleanliness is extremely important because the oil will tend to bring any foreign matter back to the compressor.

NOTICE

Risk of improper refrigerant charging. Can cause equipment damage.

Refrigerant charge must be weighed into air-cooled compressorized systems before they are started. Starting scroll and digital scroll compressors without proper refrigerant charging can cause the compressors to operate at less than 5°F (–15°C) evaporator temperature and at less than 52 psig (358 kPa). Operation for extended periods at less than 52 psig (358 kPa) can cause premature compressor failure.

4.2.1 Refrigerant Piping Guidelines for Air-cooled Systems

- Air-cooled units ship with a nitrogen holding charge. Do not vent the charge until all refrigerant piping is in place, ready for connection to the unit and condenser.
- Use copper piping with a brazing alloy with a minimum temperature of 1350°F (732°C), such as Sil-Fos. Avoid soft solders, such as 50/50 or 95/5.
- Use a flow of dry nitrogen through the piping during brazing to prevent formation of copper oxide scale inside the piping. When copper is heated in the presence of air, copper oxide forms. POE oils will dissolve these oxides from inside the copper pipes and deposit them throughout the system, clogging filter driers and affecting other system components.
- A pure dry nitrogen flow of 1-3 ft³/min (0.5-1.5 l/s) inside the pipe during brazing is sufficient to displace the air. Control the flow using a suitable measuring device.
- Ensure that the tubing surfaces to be brazed are clean and that all burrs have been removed from the ends of the tubes.
- Ensure that all loose material has been cleaned from inside the tubing before brazing.
- Protect all refrigerant line components within 18 in. (460 mm) of the brazing site by wrapping them with a wet cloth or with a suitable heat-sink compound.
- Isolate piping from building using vibration-isolating supports.
- Condensers with receivers cannot be installed below the evaporator. The maximum height of the condenser above the evaporator is 60 ft (18.3 m). Consult the factory before installing units, condensers, and receivers outside these parameters.
- Consult factory if piping run exceeds 300 ft (91 m) actual length or 450 ft (137.2 m) equivalent length.
- Install traps on hot-gas (discharge) lines at the base of vertical risers over 5 ft (1.5 m) and then for vertical rises over 25 ft (7.6 m), install a trap in 20-ft (6-m) increments or evenly-divided over the vertical rise.
- Pitch horizontal hot-gas piping down at a minimum rate of 1/2 in. per 10 ft (42 mm per 10 m) so that gravity will aid in moving oil in the direction of refrigerant/oil flow.
- Keep piping clean and dry, especially on units with R-410A refrigerant.
- Avoid piping runs through noise-sensitive areas.
- Do not run piping directly in front of discharge air stream.
- Refrigerant oil – do not mix oil types (see [Compressor Oil](#) on page 102).

Refer to ASHRAE Refrigeration Handbook for general, good-practice refrigeration piping. The indoor cooling unit has a factory-installed high-pressure safety switch in the high side refrigerant circuit. A fusible plug is installed in each Liebert® DSE receiver.

NOTE: All indoor and outdoor field refrigerant piping must be insulated 1/2 in. minimum. All outdoor insulation must be UV and ozone resistant.

- Refer to [Refrigerant Line Sizes and Equivalent Lengths](#) on the next page, for recommended refrigerant piping sizes based on equivalent pipe lengths.
- Refer to [Refrigerant Charge Requirements for Air-cooled Systems](#) on the next page, for the refrigerant-charge requirements of the system.
- Refer to [Charging Air-cooled Systems](#) on page 41, for charging information.

4.2.2 Refrigerant Line Sizes and Equivalent Lengths

Table 4.4 Recommended Refrigerant Line Sizes, OD Copper

Model	DA050		DA080 and DA085		DA125		DA150 and DA165	
	Hot Gas Line, in.	Liquid Line, in.	Hot Gas Line, in.	Liquid Line, in.	Hot Gas Line, in.	Liquid Line, in.	Hot Gas Line, in.	Liquid Line, in.
50 ft (15 m)	1-1/8	7/8	1-1/8	7/8	1-3/8	7/8	1-3/8	7/8
100 ft (30 m)	1-1/8	7/8	1-1/8	7/8	1-3/8	7/8	1-3/8	1-1/8
150 ft (45 m)	1-1/8	7/8	1-1/8	7/8	1-3/8	7/8	1-3/8	1-1/8
300 ft (91 m)	1-1/8	7/8	1-1/8	7/8	1-3/8	7/8	1-3/8	1-1/8
450 ft (137 m)*	1-1/8	7/8	1-1/8	7/8	1-3/8	7/8	1-3/8	1-1/8

*Consult factory when actual pipe length between condenser/EconoPhase and Liebert DSE unit will exceed 300 ft (91 m).
Source: DPN000788 Rev. 13

NOTE: Install a 1-3/8-in. liquid line between the receiver outlet on the condenser and the Liebert EconoPhase™ unit, regardless of line sizes indicated in **Table 4.4** above. See the piping schematics for your system in **Submittal Drawings** on page 127. For installations using pre-fabricated heat-rejection skids, included piping must be factored into total equivalent length calculation. Please consult factory for details.

4.2.3 Refrigerant Charge Requirements for Air-cooled Systems

The following tables provide the refrigerant charge requirements for the Liebert® DSE, connected piping, and condenser options.

Table 4.5 Indoor Unit Approximate Refrigerant Charge for R-410A Per Circuit

Indoor Unit Type	Model	Circuit 1 (Outer circuit), lb (kg)	Circuit 2 (Inner circuit), lb (kg)
Air-cooled	DA050	11 (5)	NA
	DA080	16 (7.3)	14 (6.4)
	DA085	18 (8.2)	16 (7.3)
	DA125	28 (12.7)	25 (11.3)
	DA150	28 (12.7)	25 (11.3)
	DA165	28 (12.7)	25 (11.3)

*System Charge = indoor unit + condenser + refrigerant receiver + refrigerant lines + EconoPhase (PRE).
For system charges over 200 lb. (90.7 kg), consult your Vertiv representative.
See **Table 9.3** on page 102 for the recommended oil for the system.

Table 4.6 MC Condenser Refrigerant Charge for R-410A Per Circuit

Standard Condenser Model	Per circuit with Small Receiver, lb (kg)	Per circuit with Large Receiver, lb (kg)
MCM080E1	17.0 (7.7)	—
MCL110E1	19.5 (8.8)	—
MCL110E2	14.0 (6.4)	—
MCM160E2	17.0 (7.7)	24.0 (10.9)
MCL220E2	21.0 (9.5)	28.0 (12.7)
MCL165E1	—	34.0 (15.4)
MCL220E1	—	42.5 (19.3)

Condenser charge includes receiver.

Small Receiver: 28-in. long, used on DA050, DA080 and DA085.

Large Receiver: 60-in. long, used on DA125, DA150 and DA165.

Table 4.7 MCV Heat-rejection Skid Approximate R-410A refrigerant required per circuit

Heat-rejection Skid*	System #	Circuit Number	Charge per circuit, lb (kg)
MCV330 Single skid with (1) PRE unit	1	1	52 (24.6)
		2	52 (24.6)

*The heat-rejection skid contains MCV condenser(s), DSE receiver(s), EconoPhase (PRE) unit(s), and all internal piping.

Table 4.8 Interconnecting Piping Refrigerant Charge for R-410A, lb per 100 ft (kg per 30 m)

Line Size, O.D., in.	Liquid Line	Hot Gas Line
7/8	19.8 (8.8)	2.3 (1.0)
1-1/8	33.8 (15.1)	3.9 (1.7)
1-3/8	51.5 (23.0)	5.9 (2.6)

Source: DPN003099, Rev. 1

Table 4.9 Liebert Pump Module Refrigerant Charge for R-410A Per Circuit

System Type	Model	Charge per Circuit, lb (kg)
Liebert® EconoPhase™ Pumping Unit	PR125	5.4 (2.5)
	PR085	
	PR050	

4.2.4 Additional Oil Requirements for Scroll and Digital-scroll Compressors

NOTICE

Risk of improper compressor lubrication. Can cause compressor and refrigerant system damage.

Failure to use oil types, viscosities and quantities recommended by the compressor manufacturer may reduce compressor life and void the compressor warranty. See **Table 9.3** on page 102 for the recommended oil for the system.

- Do not mix polyolester (POE) and mineral-based oils.
- Do not mix oils of different viscosities.
- Consult your Vertiv sales representative, visit <https://www.Vertiv.com/en-us/support/>, or contact the compressor manufacturer if questions arise.

See **Table 4.10** on the facing page, for the amount required for various system charge levels.

In addition to oil added based on system charge, additional oil is required for discharge-line field-installed traps. Standard-formed tube traps are required, see **Figure 4.2** below, and **Table 4.11** on page 40, because straight tubes and fittings used as traps require much more oil and the length of the straight tube can vary.

After the system has been fully charged with refrigerant, use a hand pump to add the additional oil at the suction side of the system while the system is running.

The amount of oil added by field service must be recorded on the tag marked "Oil Added Field Service Record," attached to each compressor. The date of oil addition must be included as well.

Figure 4.2 Standard-formed Tube Trap Versus Straight-tubes-and-fittings Trap

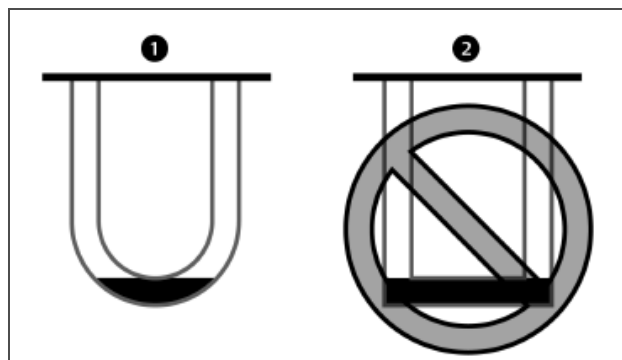

Item	Description
1	Standard-formed tube trap
2	Straight tubes and fittings trap

Table 4.10 Additional Oil Required per Refrigerant Charge

Refrigerant System Charge Per Circuit, lb (kg) *	Model					
	DA050	DA080	DA085	DA125	DA150	DA165
	Additional Oil Required Per Circuit, oz (mD)					
< 40 (18.1)	0	0	0	0	0	0
40 (18.1)	5 (150)	5 (150)	5 (150)	0	10 (300)	10 (300)
50 (22.7)	9 (270)	9 (270)	9 (270)	4 (120)	18 (530)	18 (530)
60 (27.2)	13 (380)	13 (380)	13 (380)	8 (240)	26 (770)	26 (770)
70 (31.8)	17 (500)	17 (500)	17 (500)	11 (330)	34 (1010)	34 (1010)
80 (36.3)	21 (620)	21 (620)	21 (620)	14 (410)	42 (1240)	42 (1240)
90 (40.8)	25 (740)	25 (740)	25 (740)	17 (500)	50 (1480)	50 (1480)
100 (45.4)	29 (860)	29 (860)	29 (860)	20 (590)	58 (1720)	58 (1720)
110 (49.9)	33 (980)	33 (980)	33 (980)	23 (680)	66 (1950)	66 (1950)
120 (54.4)	37 (1090)	37 (1090)	37 (1090)	26 (770)	74 (2190)	74 (2190)
130 (59.0)	41 (1210)	41 (1210)	41 (1210)	29 (860)	82 (2430)	82 (2430)
140 (63.5)	45 (1330)	45 (1330)	45 (1330)	32 (950)	90 (2660)	90 (2660)
150 (68.0)	49 (1450)	49 (1450)	49 (1450)	36 (1060)	98 (2900)	98 (2900)
160 (72.6)	53 (1570)	53 (1570)	53 (1570)	40 (1180)	106 (3130)	106 (3130)
170 (77.1)	57 (1690)	57 (1690)	57 (1690)	43 (1270)	114 (3370)	114 (3370)
180 (81.6)	61 (1800)	61 (1800)	61 (1800)	46 (1360)	122 (3610)	122 (3610)
190 (86.2)	65 (1920)	65 (1920)	65 (1920)	49 (1450)	130 (3840)	130 (3840)
200 (90.7)	69 (2040)	69 (2040)	69 (2040)	52 (1540)	138 (4080)	138 (4080)

*System Charge = indoor unit + condenser + refrigerant receiver + refrigerant lines.

For system charges over 200 lb. (90.7 kg), consult your Vertiv representative.

See **Table 9.3** on page 102, for the recommended oil for the system.

Source: DPN003950 Rev. 5

Table 4.11 Volume of Oil in Standard-form Trap by Pipe Diameter

Pipe diameter, in.	Oil volume, oz (ml)
1/2	0.2 (5.9)
5/8	0.4 (11.8)
3/4	0.6 (17.7)
7/8	0.9 (26.6)
1-1/8	1.8 (53.2)
1-3/8	3.3 (97.6)
1-5/8	5.5 (162.7)

Source: DPN003950, Rev. 5

4.2.5 Evacuation, Leak-testing, and Charging Air-cooled Systems with Receivers

Two discharge lines and two liquid lines (one discharge line and one liquid line for DA050 models) must be field-installed between the indoor unit and the outdoor condenser. See DPN002615 and DPN002340 in [Submittal Drawings](#) on page 127. for additional field-installed piping needed at the condenser.

NOTE: Keep the evaporator unit, EconoPhase, receiver, and condenser closed with their factory charge of dry nitrogen while all field piping is installed. Keep the field piping clean and dry during installation. Do not allow it to stand open to the atmosphere. When all the field interconnecting piping is in place, vent each outdoor unit's dry nitrogen charge and connect to the field piping. Finally, vent the evaporator unit's dry nitrogen charge and make its piping connection last. Follow all proper brazing practices, including a dry nitrogen purge to maintain system cleanliness. The condenser connection pipes must be wrapped with a wet cloth to keep the pressure and temperature sensors cool during any brazing.

Evacuation and Leak-testing Air-cooled Systems

For proper leak-check and evacuation, you must open all system valves and account for all check valves.

NOTE: The system includes a factory-installed check valve and an additional downstream Schrader valve with core in the compressor discharge line. Proper evacuation of the condenser side of the compressor can be accomplished only using the downstream Schrader valve. See the appropriate piping schematic for your system in [Submittal Drawings](#) on page 127.

- Starting with Circuit #1, open the service valves and place a 150 PSIG (1034 kPa) of dry nitrogen with a tracer of refrigerant. Check system for leaks with a suitable leak detector.
- With pressure still in Circuit #1, open the compressor service valves in Circuit #2.
 - If pressure increases in Circuit #2, the system is cross-circuited and must be re-checked for proper piping.
 - If there is no pressure increase, repeat step 1 on Circuit #2.
- After completion of leak testing, release the test pressure, (observe local code) and pull an initial deep vacuum of 500 microns on the system with a suitable pump.
- After 4 hours, check the pressure readings and, if they have not changed, break vacuum with dry nitrogen. Pull a second and third vacuum to 500 microns or less. Re-check the pressure after 2 hours. When the 3 checks are complete, remove the jumper hose from the service-valve fitting and the condenser, and proceed to [Charging Air-cooled Systems](#) on the facing page.

Charging Air-cooled Systems

NOTICE

Risk of improper refrigerant charging. Can cause equipment damage.

R-410A is a blended refrigerant and must be introduced and charged from the cylinder only as a liquid.

When adding liquid refrigerant to an operating system, it may be necessary to add the refrigerant through the compressor suction service valve. Care must be exercised to avoid damage to the compressor. We recommend connecting a sight glass between the charging hose and the compressor suction service valve. This will permit adjustment of the cylinder hand valve so that liquid can leave the cylinder while allowing vapor to enter the compressor.

NOTICE

Risk of improper operation. Can cause compressor failure.

Operating the unit with the EEV closed can cause compressor failure. The reheat and humidifier are disabled. A minimum of 20 psig (138 kPa) must be established and maintained for the compressor to operate. The charging function can be reset as many times as required to complete

To charge the system:

1. Check the nameplate on the indoor unit for refrigerant type to be used. Unit control configurations differ depending on refrigerant type.
2. The unit must be operating during charging, refer to [Checklist for Completed Installation](#) on page 77, the "[Liebert® MC™ Installer/User Guide](#)," and "[Liebert® EconoPhase™ Installer/User Guide](#)."
3. Calculate the amount of charge for the system. See [Refrigerant Charge Requirements for Air-cooled Systems](#) on page 36.
4. Accurately weigh in as much of the system charge as possible before starting the unit. Do not exceed the calculated charge by more than 0.5 lb (0.37 kg).
5. Close the Liebert® MC and Liebert® EconoPhase disconnect switches.
 - We recommend charging the unit with the return-air setpoint between 75°F and 85°F (24°C and 29°C).
 - The return-air temperature to the unit being charged must be stable and must be maintained greater than 65°F (18°C). If this is not possible due to lack of heat load, then the load banks must be used to offset the cooling load during start-up. See [Target Refrigerant-level in Sight Glasses at Outdoor Temperatures](#) on the next page.
6. Close the Liebert® DSE disconnect switch.
7. In the Service menu of the Liebert® iCOM controller, select *Diagnostics/Service > Diagnostics*:
 - a. *Enable Manual Mode*.

NOTE: Manual Mode times-out after 30 minutes.

- b. In Evaporator Fan options set *Motors* to *On* to operate the fan during Manual Mode.
- c. In Compressor Circuit 1 options, set *Compressor Mode* to *Charge* to operate the compressor at full capacity, energize the blower motor, and open the EEV.
- d. Reset the charge function as many times as needed to complete unit charging.

NOTE: You must establish and maintain a minimum 20 psig (138 kPa) for the compressor to operate.

- e. Repeat step 7 for Compressor Circuit 2.

8. Check the refrigerant level in the refrigerant-level sight glasses on each receiver after the unit has been operating for at least 15 minutes.

NOTE: Each receiver at the condenser has 2 sight glasses and the refrigerant level varies with outside temperature.

9. Adjust the refrigerant level in each circuit to meet the level shown in [Target Refrigerant-level in Sight Glasses at Outdoor Temperatures](#) below.
10. After adjusting the refrigerant, allow the system to operate an additional 15 minutes before checking for the need of further adjustment.

NOTE: A digital-scroll compressor can have a clear unit sight glass on the liquid line only when operating at 100% capacity. When operating with a receiver, the unit sight glass might not become clear even when operating at 100% capacity. When operating below 100%, the unit sight glass may show bubbles with each 15-second unloading cycle.

Target Refrigerant-level in Sight Glasses at Outdoor Temperatures

- 40°F (4.5°C) and lower—bottom sight glass is 3/4 full
- 40°F (4.5°C) and higher—bottom sight glass is full

If the return air temperature cannot be maintained between 75°F and 85°F (24°C and 29°C) due to lack of load, then the liquid-level receiver must be adjusted to the following if return air is between 65°F and 75°F (18°C and 24°C):

- 40°F (4.5°C) and lower—Charge to the bottom of the top sight glass.
- 40°F (4.5°C) and higher—top sight glass is 1/4 full

5 ELECTRICAL CONNECTIONS

Three-phase electrical service is required for all models. Electrical service must conform to national and local electrical codes. Refer to equipment nameplate regarding wire size and circuit protection requirements. Refer the appropriate submittal drawing, listed in [Electrical Field-connection Drawings](#) on the next page, for electrical service entrances into unit

A manual electrical disconnect switch should be installed in accordance with local codes and distribution system. Consult local codes for external disconnect requirements.



WARNING! Arc flash and electric shock hazard. Open all local and remote electric power-supply disconnect switches, verify with a voltmeter that power is Off and wear appropriate, OSHA-approved personal protective equipment (PPE) per NFPA 70E before working within the electric control enclosure. Failure to comply can cause serious injury or death. Customer must provide earth ground to unit, per NEC, CEC and local codes, as applicable. Before proceeding with installation, read all instructions, verify that all the parts are included and check the nameplate to be sure the voltage matches available utility power. The Liebert® controller does not isolate power from the unit, even in the “Unit Off” mode. Some internal components require and receive power even during the “Unit Off” mode of the controller. The factory-supplied disconnect switch is inside the unit. The line side of this switch contains live high-voltage. The only way to ensure that there is NO voltage inside the unit is to install and open a remote disconnect switch. Refer to unit electrical schematic. Follow all local codes.



WARNING! Risk of electric shock. Can cause equipment damage, injury or death. Open all local and remote electric power supply disconnect switches and verify with a voltmeter that power is off before working within any electric connection enclosures. Service and maintenance work must be performed only by properly trained and qualified personnel and in accordance with applicable regulations and manufacturers’ specifications. Opening or removing the covers to any equipment may expose personnel to lethal voltages within the unit even when it is apparently not operating and the input wiring is disconnected from the electrical source.



WARNING! Risk of improper wire sizing/rating and loose electrical connections. Can cause overheated wire and electrical connection terminals resulting in smoke, fire, equipment and building damage, injury or death. Use correctly sized copper wire only and verify that all electrical connections are tight before turning power On. Check all electrical connections periodically and tighten as necessary.



WARNING! Risk of wiring damage, short circuits and electric shock. Can cause overheated wiring, smoke, fire, activation of fire suppression systems and EMS personnel and equipment, building and equipment damage, injury or death. Insert CSA certified or UL listed bushings into holes and or knockouts used to route wiring through metal panels to protect the wire insulation from contact with sheet metal edges.

NOTICE

Risk of improper power-supply connection. Can cause equipment damage and loss of warranty coverage.

Prior to connecting any equipment to a main or alternate power source (for example: back-up generator systems) for start-up, commissioning, testing, or normal operation, ensure that these sources are correctly adjusted to the nameplate voltage and frequency of all equipment to be connected. In general, power-source voltages should be stabilized and regulated to within $\pm 10\%$ of the load nameplate nominal voltage. Also, ensure that no three-phase sources are single-phased at any time.

See transformer label for primary tap connections. Installer will need to change transformer primary taps if applied unit voltage is other than pre-wired tap voltage.

NOTICE

Risk of improper electrical connection of three-phase input power. Can cause backward compressor rotation and unit damage. Service technicians should use a gauge set on the system during the initial start up to verify that the three-phase power is connected properly. The EC fans are not a reliable indicator of proper connection. The blowers will rotate the same direction, regardless of the three-phase power input. Three-phase power must be connected to the unit line voltage terminals in the proper sequence so that the compressors rotate in the proper direction. Incoming power must be properly phased to prevent compressors from running backward. We recommend checking the unit's phasing with proper instrumentation to ensure that power connections were made correctly. We also recommend verifying discharge and suction pressures during start up to ensure that the compressors are running in the correct direction.

NOTE: Seal openings around piping and electrical connection to prevent air leakage. Failure to do so could reduce the unit's cooling performance.

The electrical and unit-to-unit connections are described in the submittal documents included in the [Submittal Drawings](#) on page 127.

The following tables list the relevant documents by number and title.

Table 5.1 Electrical Field-connection Drawings

Document Number	Title
DPN004387	Electrical Field Connections, Upflow & Downflow, DA050, DA080, and DA085 Models
DPN004388	Electrical Field Connections, Downflow Models, DA125, DA150, and DA165
DPN003284	CANbus cable connections between indoor unit, 1 Liebert® MC condenser and optional Liebert® EconoPhase pump
DPN002361	CANbus cable connections between indoor unit, 2 Liebert® MC condensers and optional Liebert® EconoPhase pump
DPN003886	CANbus cable connections between indoor unit, Liebert® MCV condenser
Unit-to-Unit Networking	
DPN004351	Liebert® iCOM Unit-to-unit Network Connections

6 EC FANS AND PLENUMS

Depending on the air-distribution options of your unit, you may have EC fans and/or plenums to install.

6.1 Downflow Units with EC Fans

DSE downflow models are equipped with EC fans that may operate in the fully-raised position or lowered into the floor stand for increased efficiency from reduced air resistance.



WARNING! Risk of very heavy 125-lb (56.7-kg) fan modules dropping downward suddenly. Can cause injury or death. Support fan modules before removing mounting hardware. Use caution to keep body parts out of the fan modules pathway during repositioning. Only properly trained and qualified personnel should work on this equipment.



CAUTION: Risk of improper handling of heavy and lengthy parts. Can cause personal injury and equipment damage. Cabinet panels can exceed 5 ft (1.5 m) in length and weigh more than 35 lb (15.9 kg). Follow relevant OSHA lifting recommendations and consider using a two-person lift for safe and comfortable removal and installation of cabinet panels. Only properly trained and qualified personnel wearing appropriate, OSHA-approved PPE should attempt to remove or install cabinet panels.

NOTE: Use fans either in their original raised position or with the fans in their fully-lowered position. Suspension of fans in an intermediate position will directly affect product performance and is not recommended.

6.1.1 Lowering the EC Fans into the Floor Stand on Downflow Models

NOTE: If your floor-stand height is between 9 in. (228.6 mm) and 21 in. (533.5 mm), please contact the factory before attempting to lower the fans into the floor stand. If the floor-stand height is 24 in. (609.6 mm) up to 48 in. (1219.2 mm), the fans can be installed and lowered into the floor stand.

Tools Needed

- 1/2-in. hex socket and wrench
- Factory-supplied jack, crank and jack support
- Cable tie cutter

To lower the fans:

1. Remove the middle and bottom panels from the front of the unit.
2. For ease of fan lowering, We recommend removing the infrared humidifier.
3. Position the factory-supplied jack and jack support under the fan to be lowered.
4. Raise the jack to safely support the fan before removing any hardware.

NOTE: The jack should be centered between the first and second set of tabs on the jack support (see Detail A in **Figure 6.1** on the next page).

5. Cut and remove the cable tie that holds the wiring loop to the blower mounting plate. All other cable ties that route the fan wiring should remain intact.
6. Remove the six 1/2" hex head screws. Retain the hardware for later use.

Figure 6.1 Lowering EC fans into floor stand, steps 1 through 6

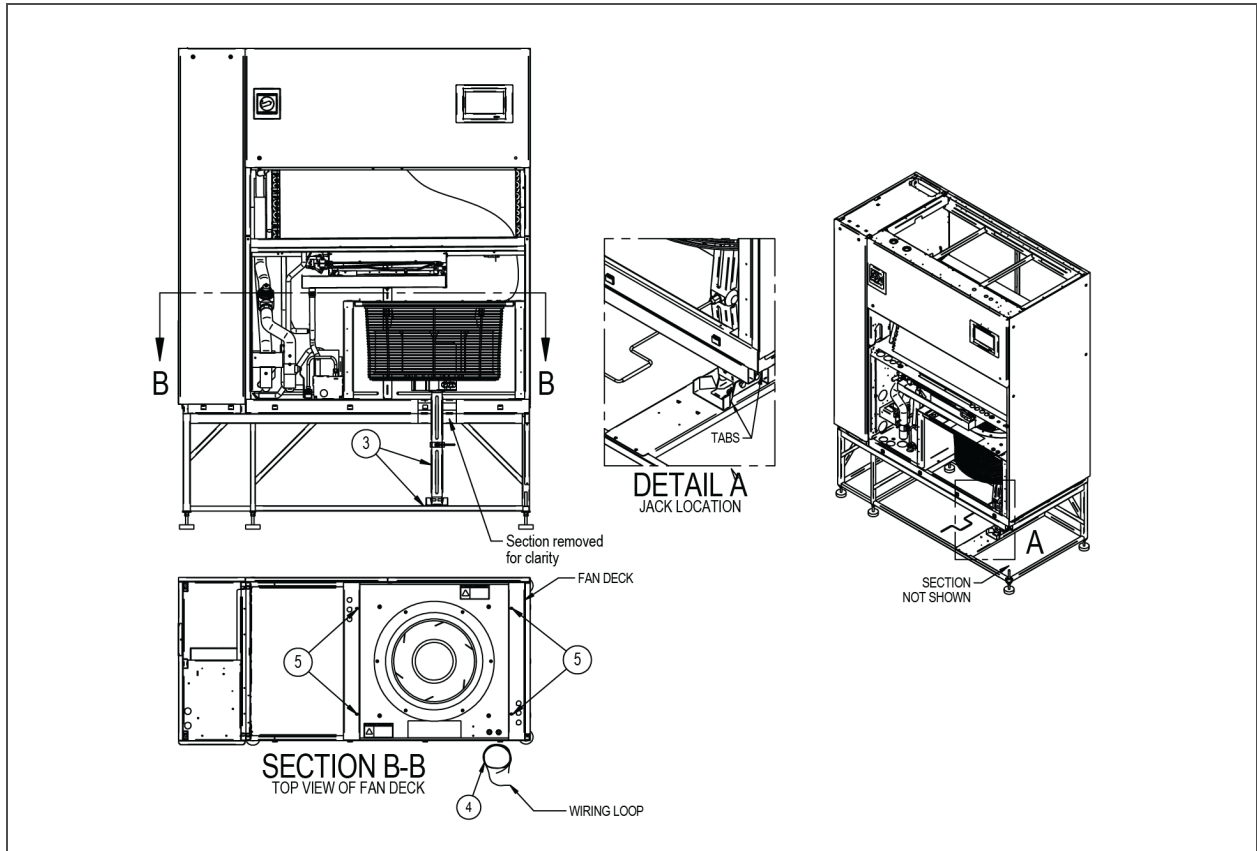

7. Using the jack, lower the fan module slowly until it rests on the frame of the unit.

NOTICE

Risk of equipment snagging cables and wiring. Can damage the unit wiring and components.

Carefully monitor the position of the EC-fan wire harnesses and other parts while lowering the fan to be sure that they are not caught or pinched.

8. Secure the fan module in the fully lowered position by reinstalling the hex head screws directly to the frame. Screw clearance holes are provided in the fan module.

NOTE: Not all hardware retained will be used to secure the fans in the lowered positioned.

9. Repeat steps 3 through 8 to lower remaining fan modules.

Figure 6.2 Lowering EC fans into floor, steps 7 through 8

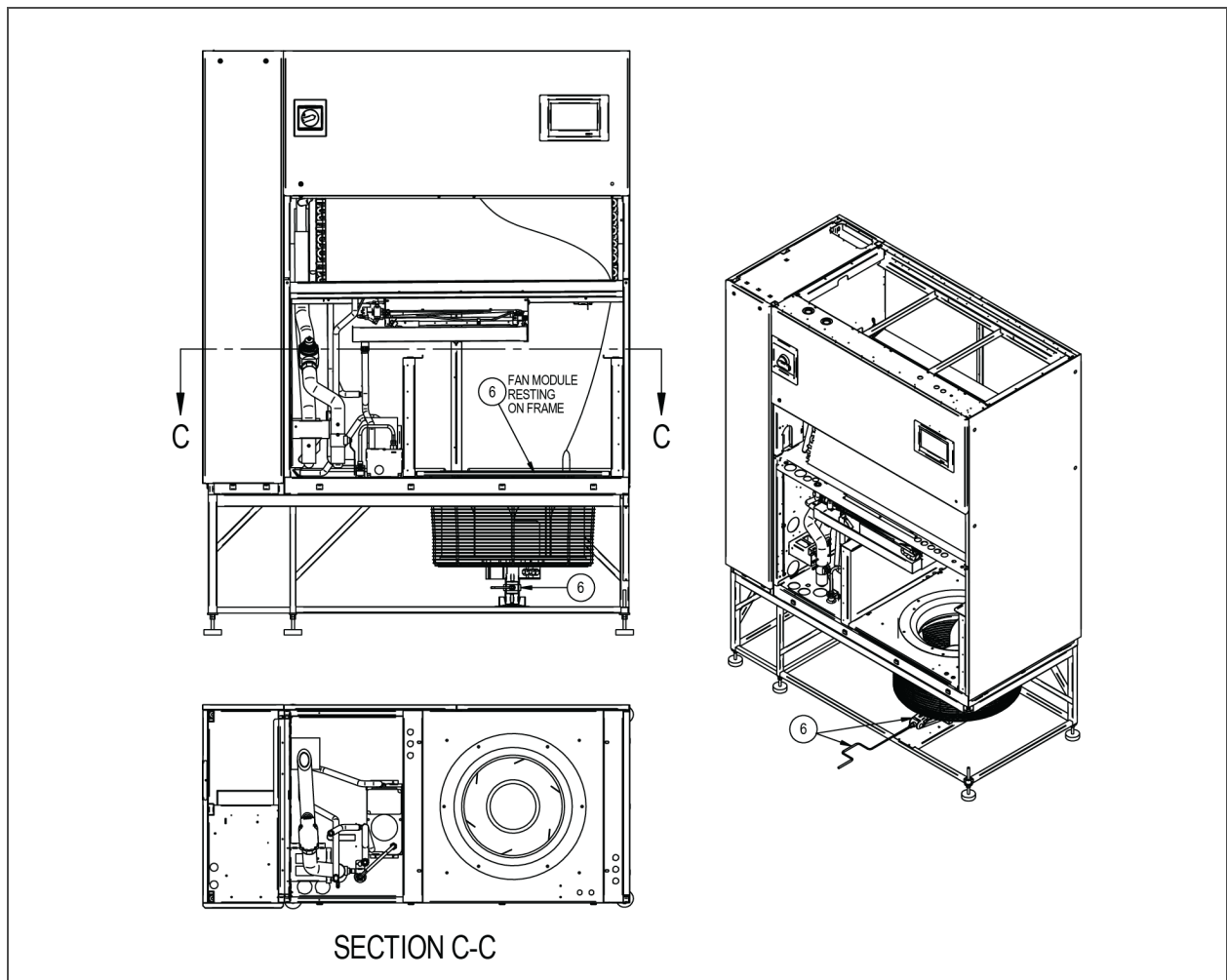

6.2 Downflow Unit Filter Plenums

Filter plenums are installed on DSE downflow models DA125, DA150 and DA165 and are required for operation.

Read all instructions before installing plenums.



WARNING! Arc flash and electric shock hazard. Open all local and remote electric power disconnect switches, verify with a voltmeter that power is off and wear appropriate personal protective equipment per NFPA 70E before working within the electric control enclosure. Failure to comply can cause injury or death.



WARNING! Risk of falling plenum. Can cause injury or death. Attach the plenum to the unit only as described in these instructions.



WARNING! Risk of contact with sharp edges and improper handling of very heavy parts. Can cause equipment damage, injury or death. Use extreme caution and install the plenum to the unit only as described in these instructions. A minimum of two (2) qualified HVAC installation personnel are required to install this plenum. Wear OSHA approved safety headgear, eye protection, gloves, arm protection and shoes when moving, lifting and installing the plenum.

To install the plenum:

1. Apply gasket tape to the top perimeter of the unit's frame, making sure to set-back the tape applied to the front perimeter 2 in. from the front panels.
2. Leaving the filters in the plenum, place the plenum on top of the unit and align it with the back and sides of the unit as shown in **Figure 6.3** below.

Figure 6.3 Place plenum on unit and align

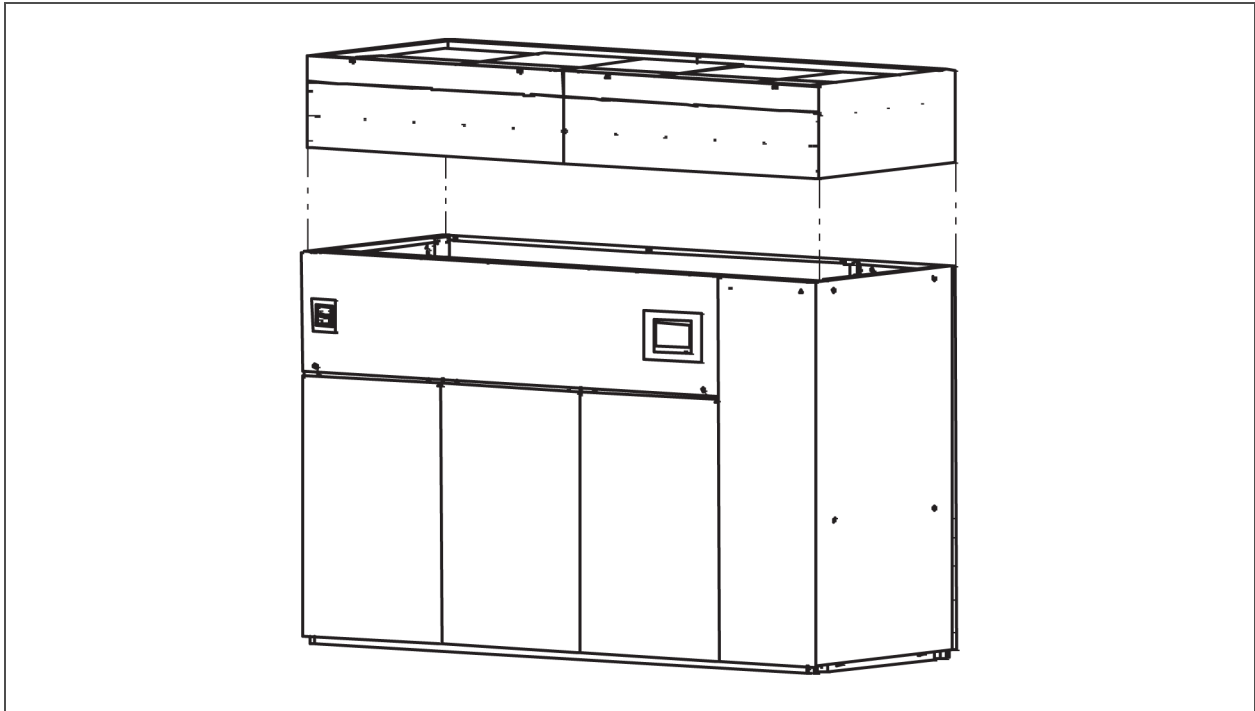

3. Remove the filters and access doors from the plenum.
4. From the inside, align the slots in the plenum with the screw-bite holes in the frame and attach the plenum to the top of the unit using twelve (12) ¼-14 screws in the locations shown in **Figure 6.4** below.

Figure 6.4 Attach filter plenum to unit

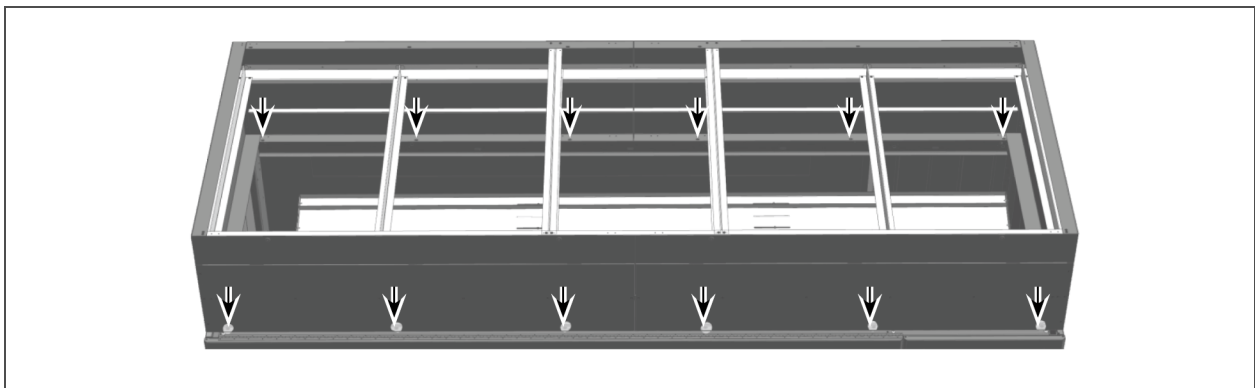

5. Refer to **Figure 6.5** below and route the filter-clog-sensing tube:
 - Cut the cable tie to loosen the bundled tube.
 - Route the tube through the bushing, then to the hole in the filter where it exits the electric box.
6. Replace the filters and attach the doors to complete installation.

Figure 6.5 Routing Filter-Clog-Sensing Tube

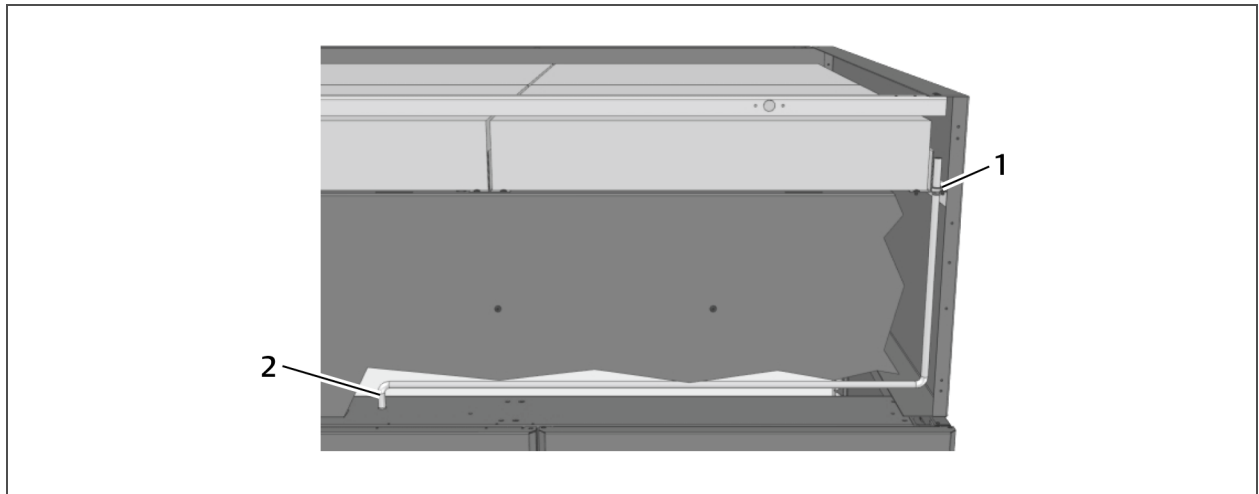

Item	Description
1	Route the tube through the bushing.
2	Tube exits electric box.

6.3 Upflow-unit Plenums with EC Fans

EC fans on upflow units are mounted external to the unit in a factory-provided plenum. The plenum distributes air to the conditioned space through adjustable, double-deflection grilles, or connects with field-supplied duct work.

Read all instructions before installing plenums and EC fans.



WARNING! Risk of electric shock and contact with high-speed moving parts. Open all local and remote electric power-supply disconnect switches, verify with a voltmeter that power is off, and visually verify that all fans have stopped rotating before opening doors, removing panels, and working within the unit cabinet. This unit may start and stop operating automatically. Do not assume that electric power is off when the unit is not operating.



WARNING! Risk of contact with sharp edges, exposed fasteners, and improper handling of very heavy parts. Can cause equipment damage, injury or death. Use extreme caution, wear appropriate, OSHA-approved PPE, and install the EC fan(s) and plenum to the unit only as described in these instructions.

More than one person may be required to complete the assembly and installation. Installer(s) must be properly trained and qualified to lift, move and manipulate very heavy equipment from floor level to the top of the unit.

Wear appropriate, OSHA-approved PPE when moving, lifting and installing the fan(s) and plenum.

Equipment used in moving, lifting and installing the fan(s) and plenum must meet OSHA requirements and be rated for the weight of the fan(s) and plenum. If ladders are used, verify that they are rated for the combined weight of the fan(s), plenum and installer(s) as loaded. EC Fan and plenum weights are specified in **Table 6.1** on the next page and **Table 6.2** on the next page.

Read and follow the lifting equipment and/or ladder manufacturer's operating instructions and safety requirements.

NOTE: Grilled plenums are intended for use in upflow configurations only. Non-grilled plenums provide service access on upflow units with duct work.

NOTE: We recommend using a duct lift or scissors lift when installing the EC-fan assemblies on top of the unit.

Figure 6.6 Equipment recommended to install the upflow plenum and EC fans

- Ladders
- Over-head winch or crane
- Duct lift
- Lift chains with hooks
- Scissor lift

6.3.1 Assembly Inspection

1. Inspect all items for visible or concealed damage. Immediately report any damage to the carrier and file a damage claim, sending a copy of the claim to your local sales representative.
2. Move to the installation location, remove items from packaging and verify that the assembly number is correct:
 - Refer to **Table 6.1** below to verify plenum number by unit length, plenum height, quantity, and grille size.
 - If a compressor-section plenum is included, refer to **Table 6.4** on page 55 to verify plenum number by size.
 - Refer to **Table 6.2** below to verify EC fan number by unit voltage.
 - Verify that the fan-motor voltage rating is appropriate for the marked voltage rating of the cooling unit.
3. Verify that all assembly contents are present:
 - Refer to **Figure 6.7** on the facing page and **Table 6.3** on page 54 to verify plenum parts.
 - If a compressor-section plenum is included, refer to **Figure 6.9** on page 56 and **Table 6.4** on page 55 to verify plenum parts.
 - Refer to on page 55 to verify EC-fan parts.

Table 6.1 Plenum Assembly Numbers, Plenum Heights, Plenum Weights and Unit Lengths

Plenum Height:	24 in. (610 mm)	30 in. (762 mm)	36 in. (917 mm)
Unit Description	Assembly Number and Weight		
DA080U-DA085U			
Non-grilled plenum, length 82 in. (2089 mm)	312208G1 - 112 lb (51 kg)	312208G2 - 136 lb (62 kg)	312208G3 - 156 lb (71 kg)
Front discharge, length 82 in. (2089 mm)	31298G1 - 160 lb (73 kg)	—	—
Rear discharge, length 82 in. (2089 mm)	312411G1 - 173 lb (79 kg)	—	—

Table 6.2 EC-fan Assembly Numbers, Weights and Voltage

Assembly no. and weight	Fan size (Nominal)	Voltage / kW	Unit Size
312583G3 - 102 lb (46 kg)	22 in. (560 mm)	460 V / 3.1 kW	DA080U - DA085U
312583G4 - 102 lb (46 kg)		208 V / 2.9 kW	

Plenum Parts Identification

Figure 6.7 Plenum parts identification

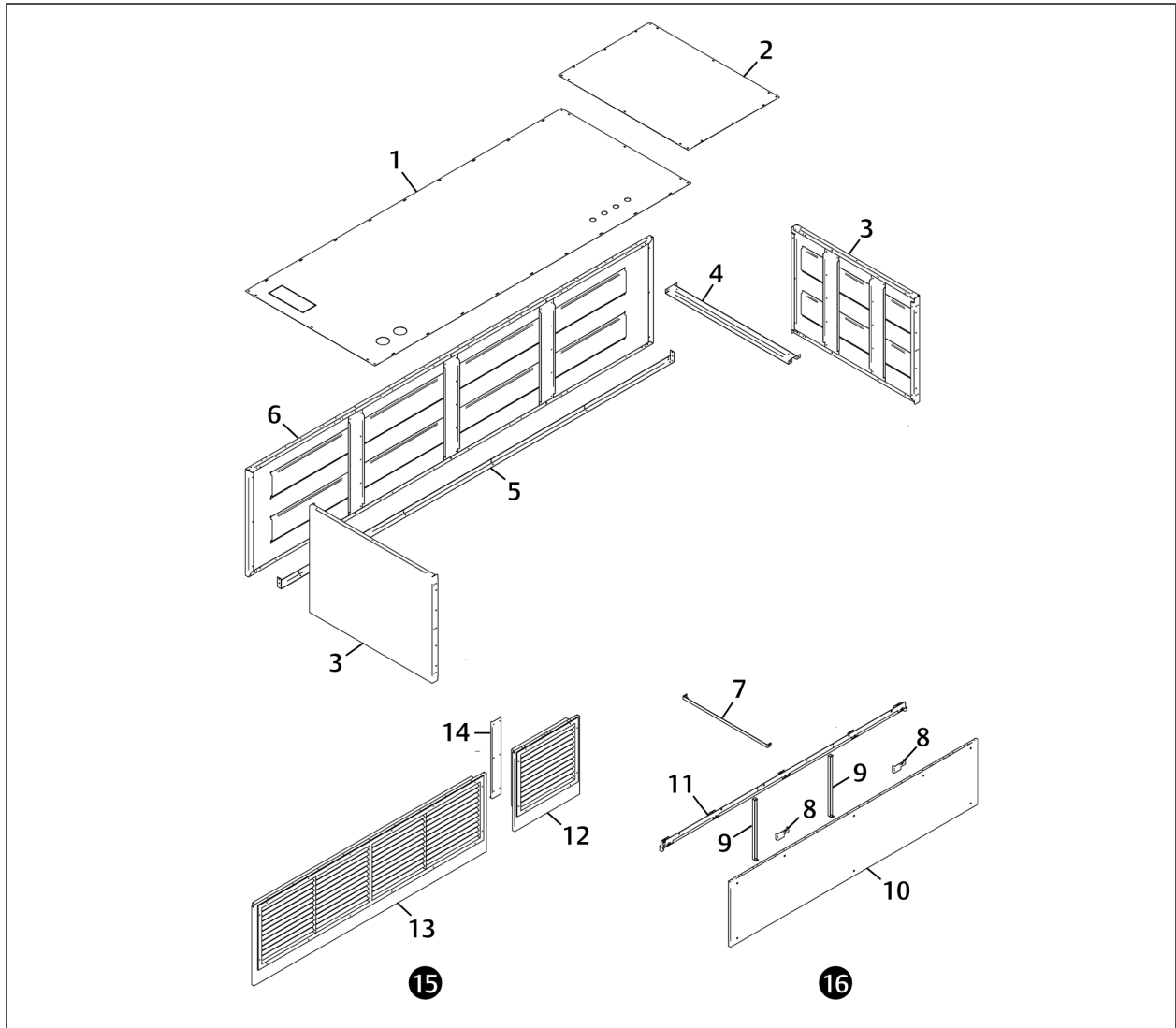

NOTE: Not all parts are used in all models:

NOTE: Units shorter than 132 in. (3353 mm) do not include short front and rear grilled panels or channel panels.

NOTE: Only non-grilled plenums on 132-in. (3353-mm) units include a plenum brace.

NOTE: Units shorter than 132 in. (3353 mm) have only 1 top panel (with holes).

NOTE: Front-discharge units do not include a top frame or channel frames. 86-in. (2184 mm) and 73-in. (1854 mm) units do not include channel frames or panel-mounting brackets.

Table 6.3 Plenum Parts and Quantities

Item	Description	Quantity
1	Top panel (with holes)	1
2	Top panel (plain)	1
3	Side panel	2
4	Top-panel brace (Non-grilled plenum)	1
5	Angle bracket, 59-in. - 105-in.	1
6	Front/Rear solid panel	1
7	Top-panel brace (Rear-discharge plenum)	1
8	Panel mounting bracket	1 or 2
9	Channel frame	varies
10	Front solid panel	1
11	Top frame	1
12	Short front grilled panel	1
13	Front grilled panel	1
14	Channel panel	1 or 2
15	Assembly view of long and short front/rear grilled panels	N/A
16	Assembly view of front solid panel.	N/A
Not shown	Angle bracket	varies
Not shown	Washer 1/4	varies
Not shown	Bolt 1/4-20 x 1	varies
Not shown	Sheet-metal screw #8-18 x 1/2	varies
Not shown	Insulation tape	varies

EC Fan Parts Identification

Figure 6.8 EC-fan assembly

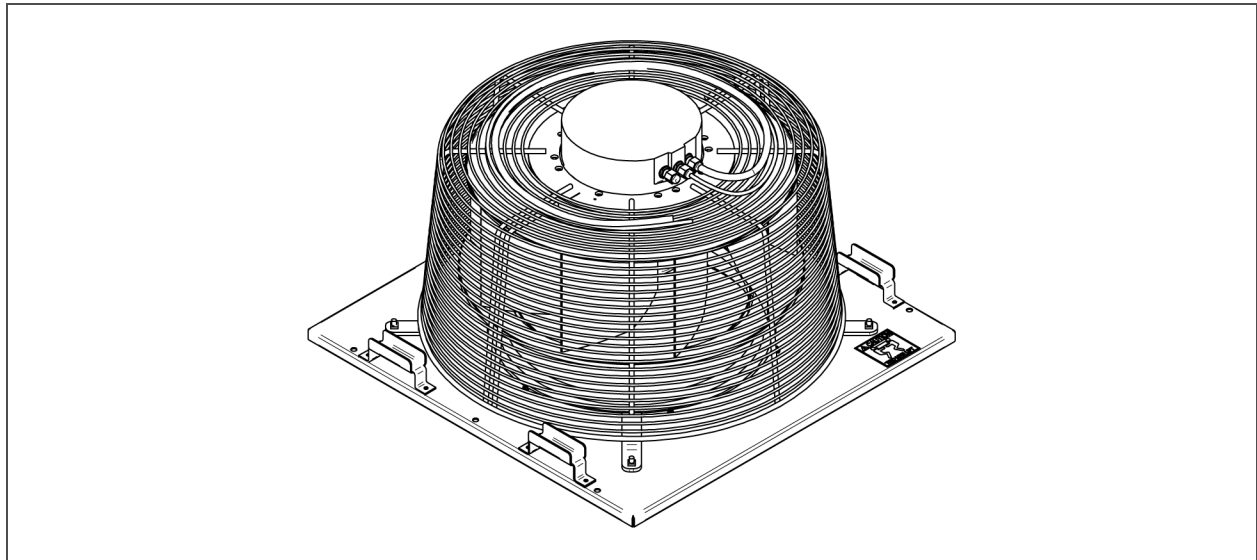

Item	Description	Quantity
Not shown	Washer	6
Not shown	Bolt	6
Not shown	Spacer	6

Compressor-plenum Parts Identification

Table 6.4 Compressor Plenum Assembly Numbers, Weights and Size

Assembly no. and weight	Plenum size, in. (mm)
313202G10 - 27 lb (11 kg)	17 x 24 (432 x 610)
313202G11 - 30 lb (14 kg)	17 x 30 (432 x 762)
313202G12 - 33 lb (15 kg)	17 x 36 (432 x 914)

Figure 6.9 Compressor plenum parts identification

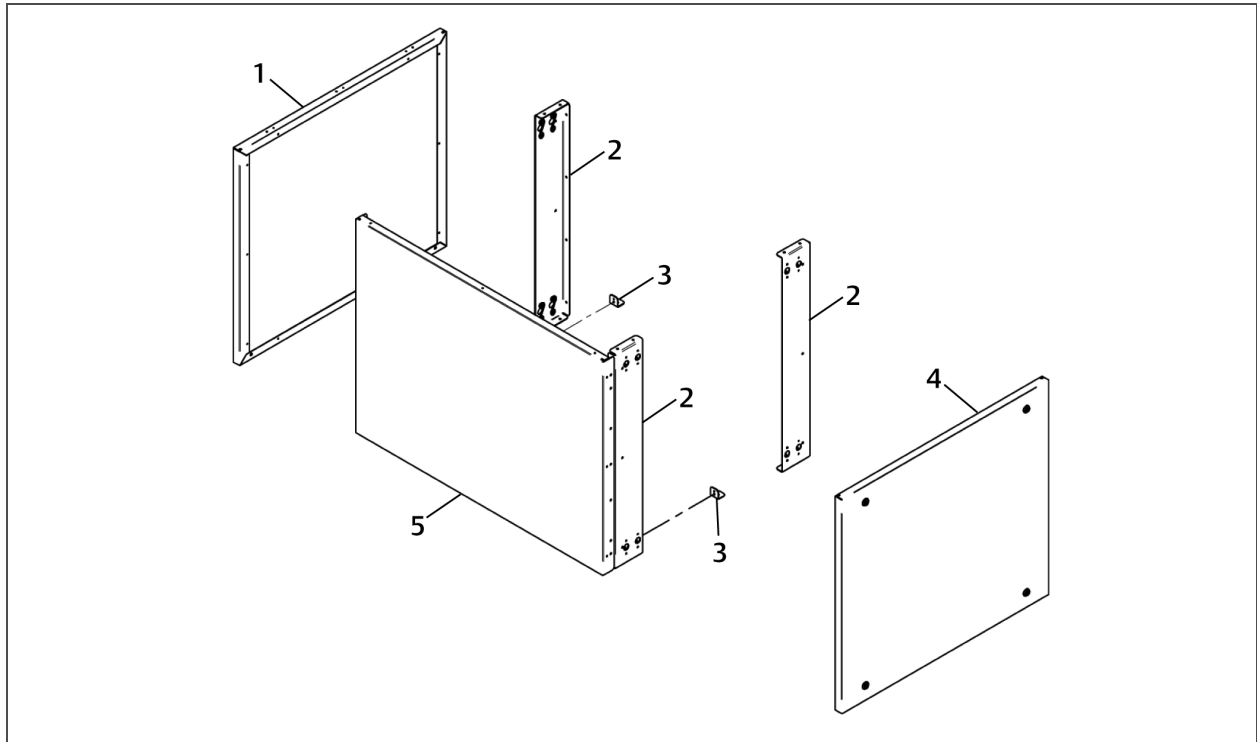

NOTE: Not all parts are used in all plenum sizes: 26-in (660-mm) wide compressor plenums include 3 angle-mounting brackets and a front panel with quarter-turn fasteners.

NOTE: Compressor plenums shorter than 26 in. (660 mm) include 2 angle-mounting brackets and do not include a front panel with quarter-turn fasteners.

Table 6.5 Compressor plenum parts and quantities

Item	Description	Quantity
1	Front/Rear panel	1 or 2
2	Angle-mounting channel	2 or 3
3	Angle-mounting bracket	2
4	Front panel with quarter-turn fasteners	1
5	Side panel	1
Not shown	Sheet-metal screw	varies

6.3.2 Assemble plenum rear and side panels

NOTE: Grilles can be installed on different sides of the plenum depending on discharge configuration. Verify grill location and install according to facility-layout plans.

NOTE: Electrical connections and some piping connections are made through the plenum. Plan accordingly.

1. Apply factory-supplied gasket/insulation tape to plenum panels, **Figure 6.10** on the next page:
 - On front solid panels install the gasketing on the inner edge of the sides, and along the top and bottom edges.
 - On front and rear gridded panels, install the gasketing on the inner edge of the sides, and along the top and bottom edges, except on 105-in. (2673-mm) plenums, do not install gasketing along the edges where the short and long panel connect.
 - On rear solid panels, install the gasketing on the inner edge of the sides and along the bottom edge only.
 - On side panels, install the gasketing along the bottom edge.

Figure 6.10 Apply Gasket/Insulation Tape

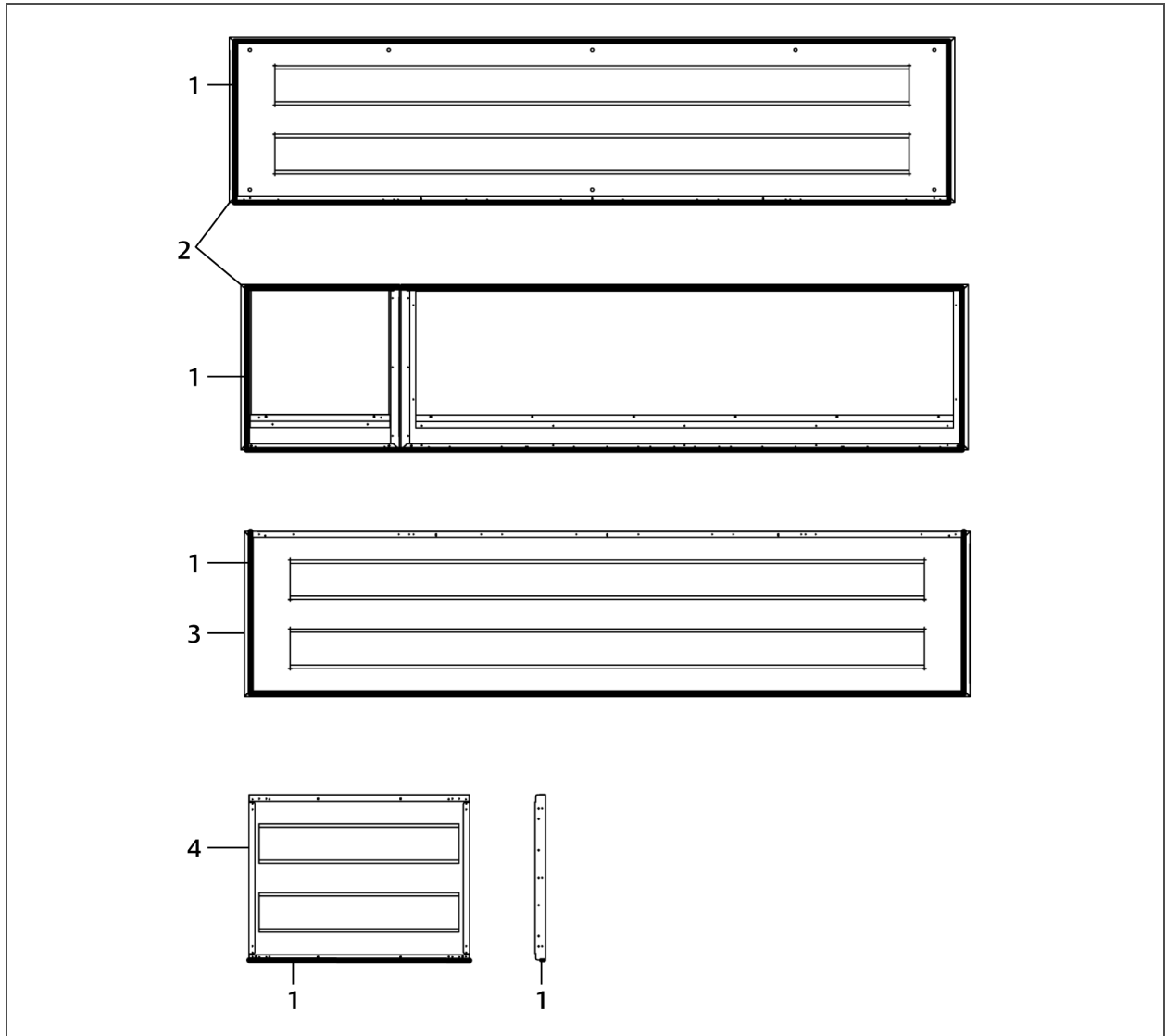

Item	Description
1	Gasketing/Insulation tape
2	Front solid panel, Front and Rear grilled panels
3	Rear solid panel
4	Side panel

2. If assembling a solid rear plenum or a gridded rear plenum shorter than 105 in. (2673 mm), skip to step 3.
– or –
If assembling a 105-in. (2676 mm) gridded, rear plenum, attach the long and short panel together using the channel panel and sheet-metal screws as shown in **Figure 6.11** below.

Figure 6.11 105-in. Gridded Rear-Panel Assembly

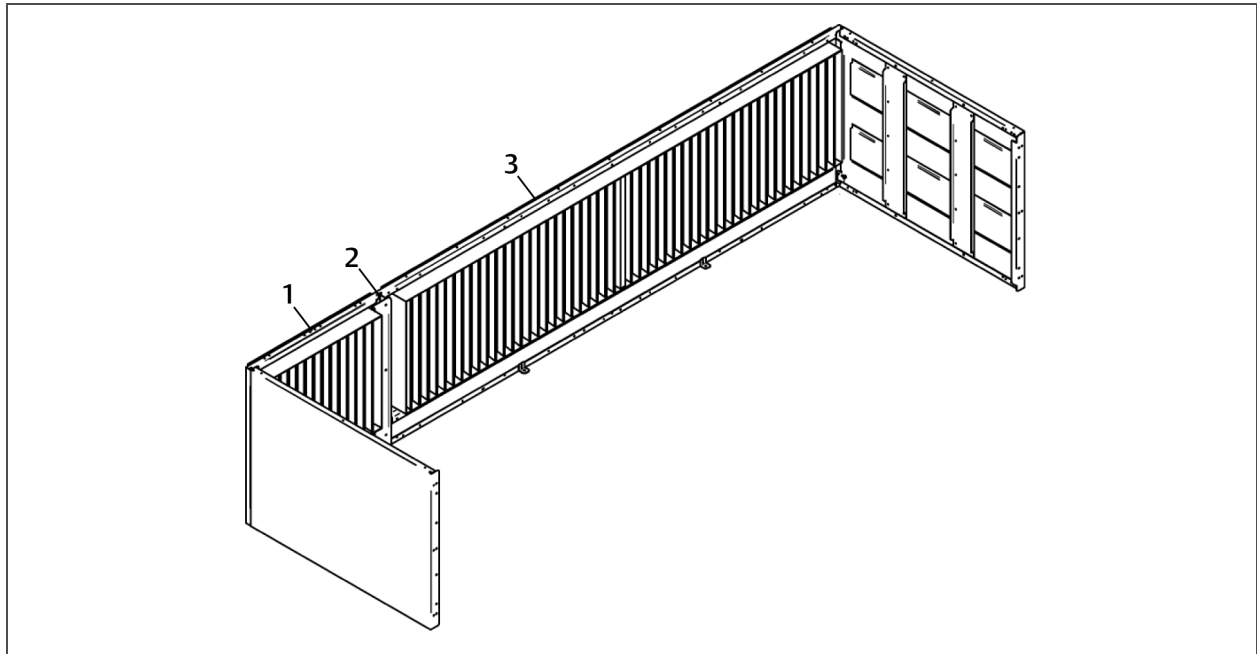

Item	Description
1	Short rear panel
2	Channel panel
3	Long rear panel

3. Attach the 2 side panels to each end of the rear-panel assembly using 10 sheet-metal screws as shown in **Figure 6.12** below.

NOTE: Figure 6.12 below, shows a non-grilled rear plenum as an example. If your unit is rear-discharge, the rear plenum panels have grilles.

Figure 6.12 Attach Side Panels to Rear Panel

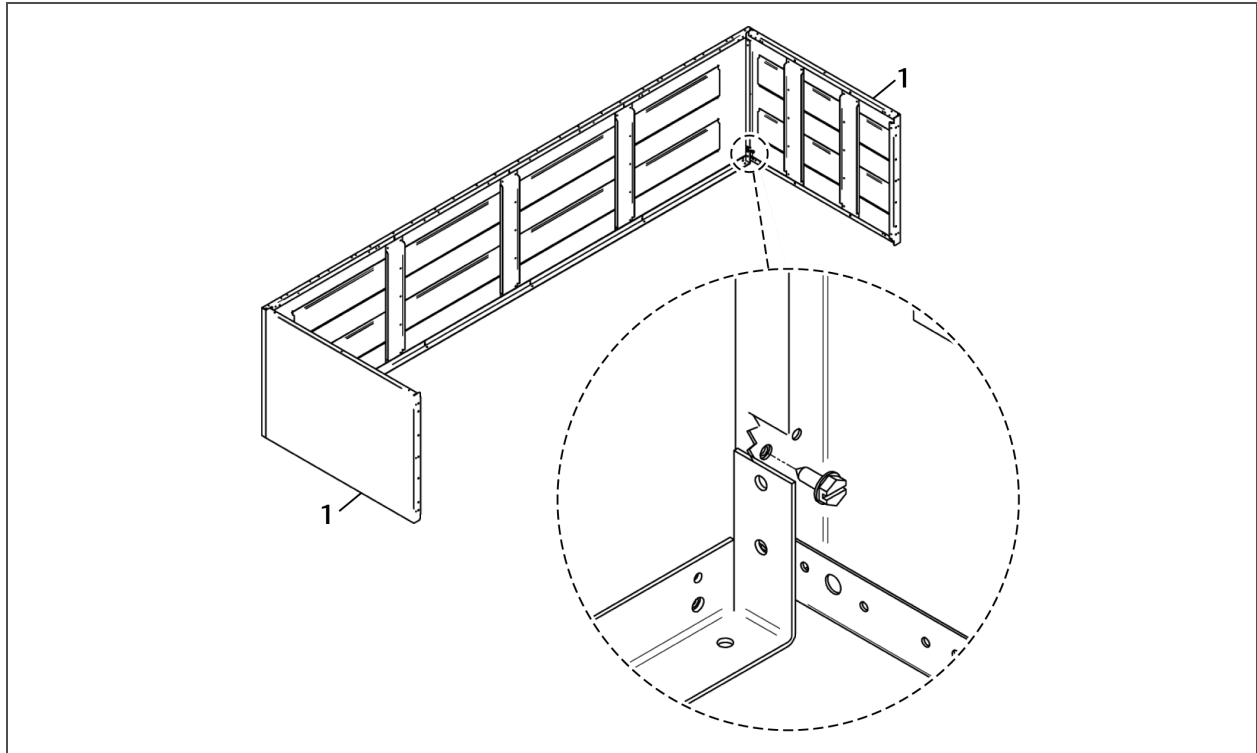

Item	Description
1	Side panel

6.3.3 Wire the EC Fans



WARNING! Risk of cut insulation and damaged wires. Can cause short circuits, overheated wiring, smoke, fire, activation of fire suppression systems and EMS personnel, equipment damage, loss of power to fans, injury or death. Verify that all wiring connections are tight and that all wiring is contained within the junction box prior to closing and securing the cover.

Black-sleeved harness contains fan-control wires. Grey-sleeved harness contains motor high-volt connection.

1. Refer to **Figure 6.13** on the facing page, **Figure 6.14** on page 62, and **Figure 6.15** on page 63, to route the wire harnesses and insert them into the indicated openings on the junction boxes.
 - You may need to remove existing wire ties that hold the harness to the fan cage.

NOTE: Do not route the wiring over the handles on the EC-fan assembly.

2. Connect the wires inside the junction box:
 - Between fan 1 and 2 on 2- and 3-fan units, refer to **Figure 6.14** on the next page.
 - On single-fan or fan 3 of 3-fan units, refer to **Figure 6.15** on page 63.
3. Use provided wire ties to secure the wire harnesses to the fan cage to prevent harness movement when fans are running.

Figure 6.13 EC-fan junction boxes

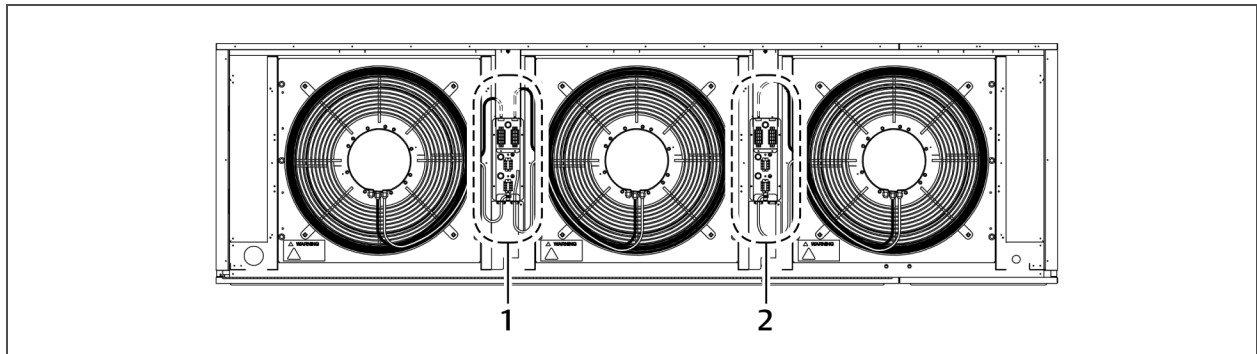

Item	Description
1	Junction box between fans 1 and 2 on 2- and 3-fan unit
2	Junction box for 1- or 3-fan unit

Figure 6.14 Junction box between fans 1 and 2

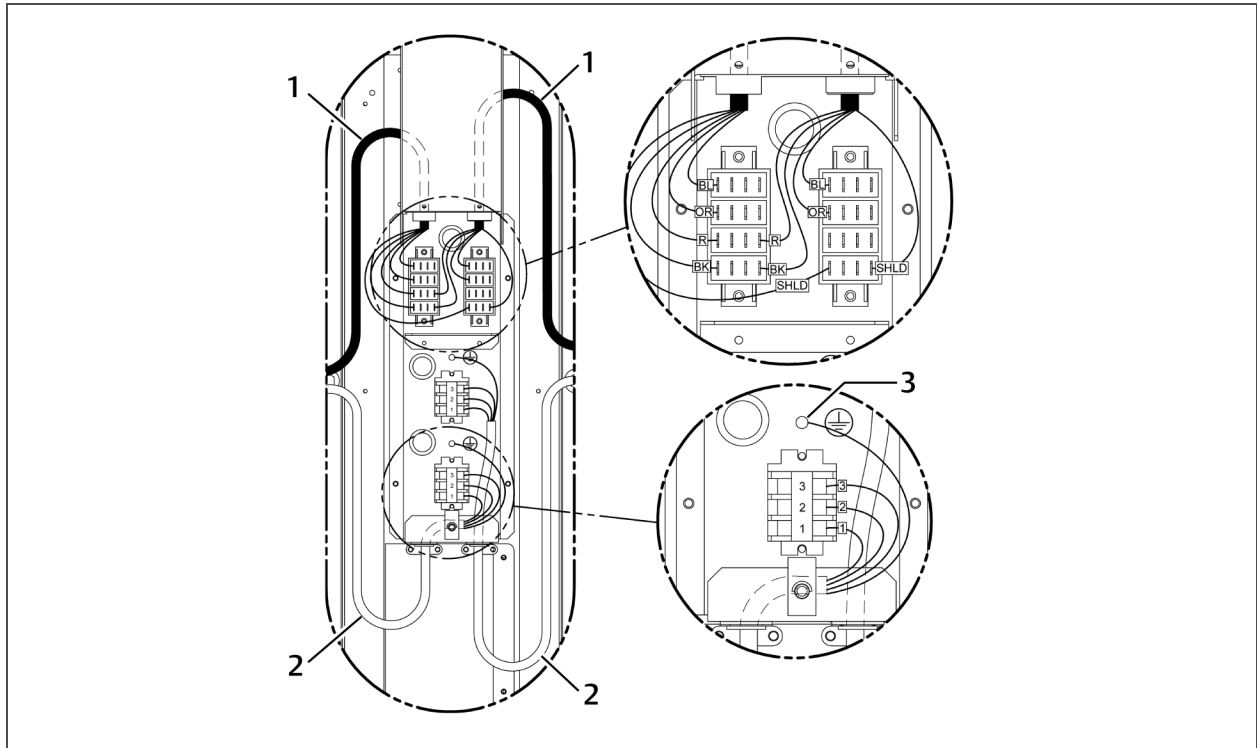

NOTE: For the high-volt terminal blocks, the wire-termination torque is 16-20 in-lbs.

Item	Description
1	Fan (low-volt) wiring
2	Motor (high-volt) wiring
3	Green/Yellow ground wire

Figure 6.15 Junction box for single fan or fan 3

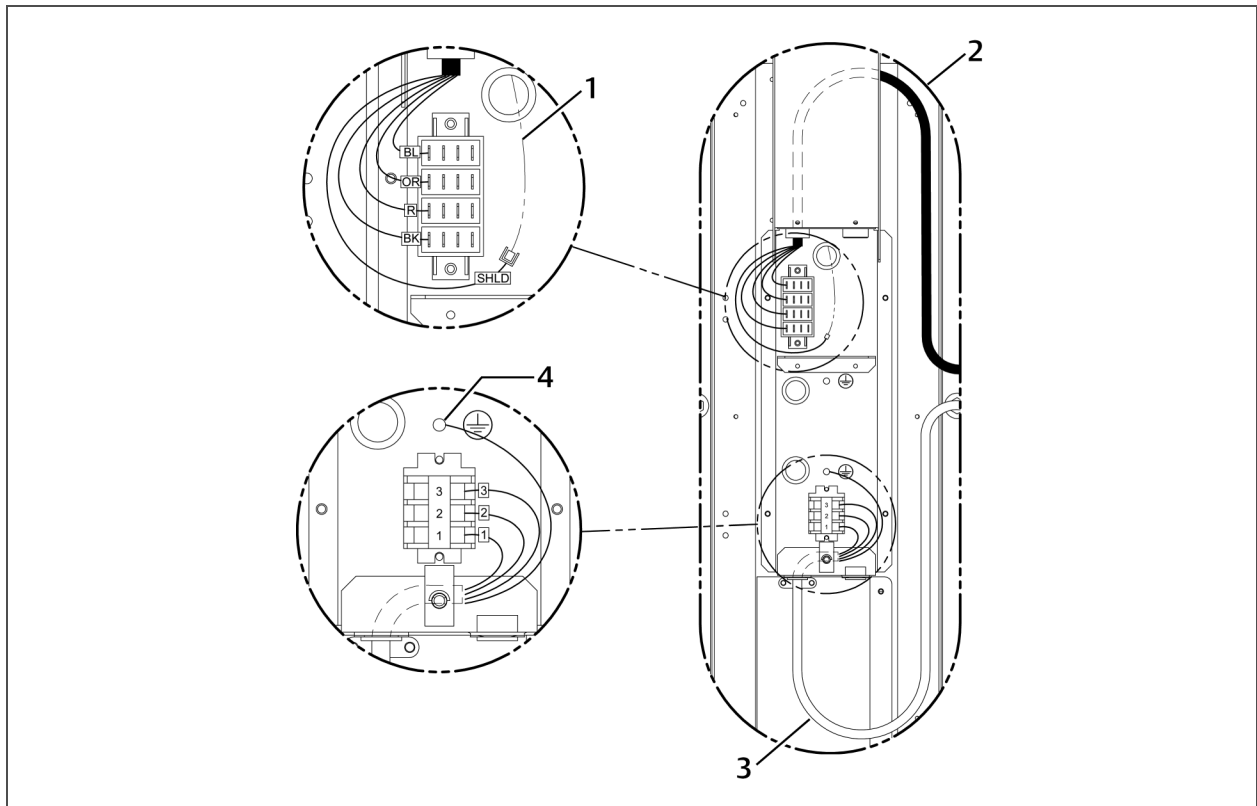

NOTE: For the high-volt terminal blocks, the wire-termination torque is 16-20 in-lbs.

Item	Description
1	SHLD wire from unit harness
2	Fan (low-volt) wiring
3	Motor (high-volt) wiring
4	Green/Yellow ground wire

6.3.4 Install front panels on plenum

Non-grilled plenum front panels require assembly and attachment before mounting the panels, see [Non-grilled and rear-discharge front-panel assembly](#) on the next page.

Grilled plenums do not require a frame assembly, see [Front-discharge front-panel assembly](#) on page 71.

Non-grilled and rear-discharge front-panel assembly

1. Attach the panel-mounting bracket(s), **Figure 6.16** below:
 - Attach the right-side panel-mounting bracket to the top of the unit using 2 bolts and 2 washers and to the side panel using 2 sheet-metal screws as shown in the detail view in **Figure 6.16** below.
 - If a second panel-mounting bracket is included, attach in the center location using 2 bolts and 2 washers.

Figure 6.16 Panel-mounting bracket attachment

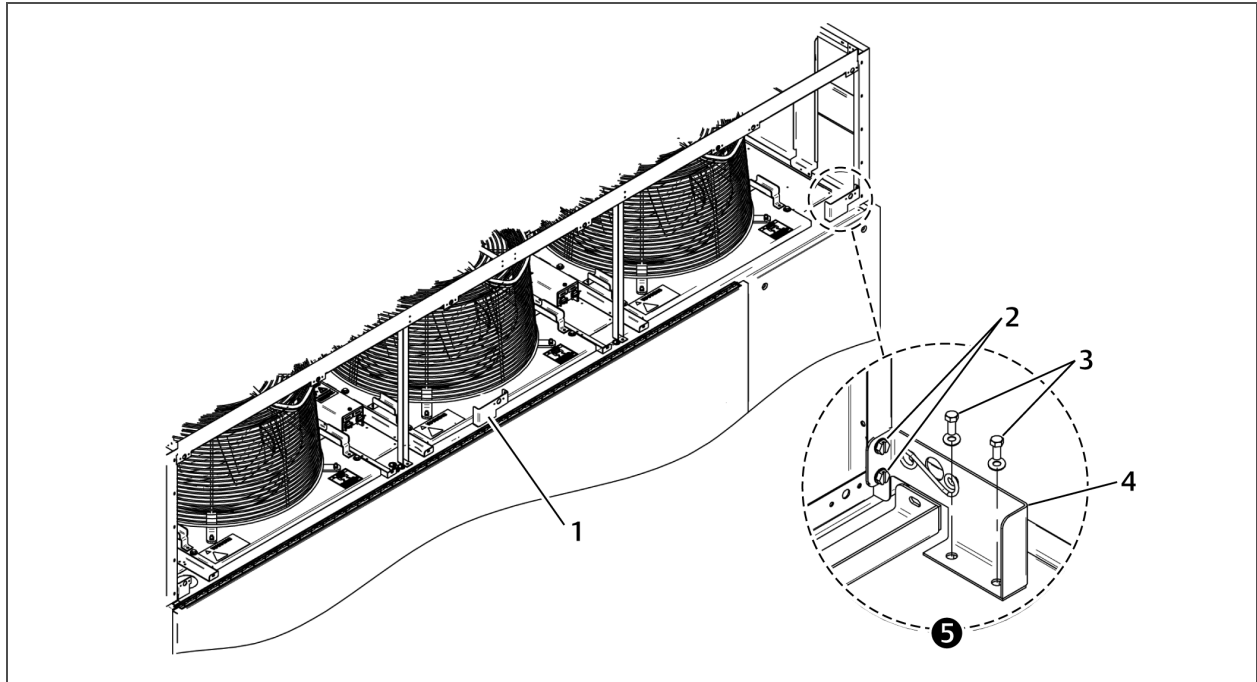

Item	Description
1	Panel mounting bracket
2	Sheet-metal screws
3	Bolt and Washer
4	Panel mounting bracket
5	Detail view of right-side bracket installation. Shown from inside the plenum.

2. Attach the channel frame(s) to the top frame using 3 sheet-metal screws:
 - For non-grilled plenums, make sure the dimple shown in **Figure 6.17** below, is on the bottom flange of the top frame.
 - For rear-discharge plenums, make sure the dimple shown in **Figure 6.17** below, is on the top flange of the top frame.

NOTE: The number of channel frames varies depending on the size of plenum.

Figure 6.17 Channel frame top attachment

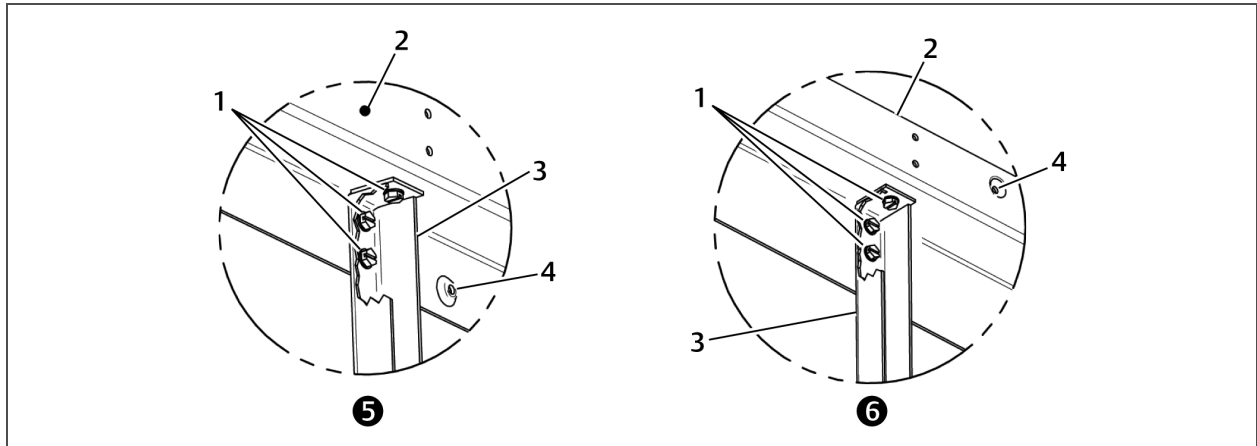

Item	Description
1	Sheet-metal screws
2	Top frame
3	Channel frame
4	Dimple
5	Attachment on non-grilled plenum. Shown from bottom.
6	Attachment on rear-discharge plenum. Shown from bottom.

3. Attach the assembled top/channel frame to the side panels on top of the unit:
 - For non-grilled plenums, refer to **Figure 6.18** below, and use 2 sheet-metal screws on each end.
 - For rear-discharge, refer to [Top frame attachment to sides](#) below, and attach the smaller flange to the side panel using 2 sheet-metal screws on each end.

Figure 6.18 Top frame attachment to sides

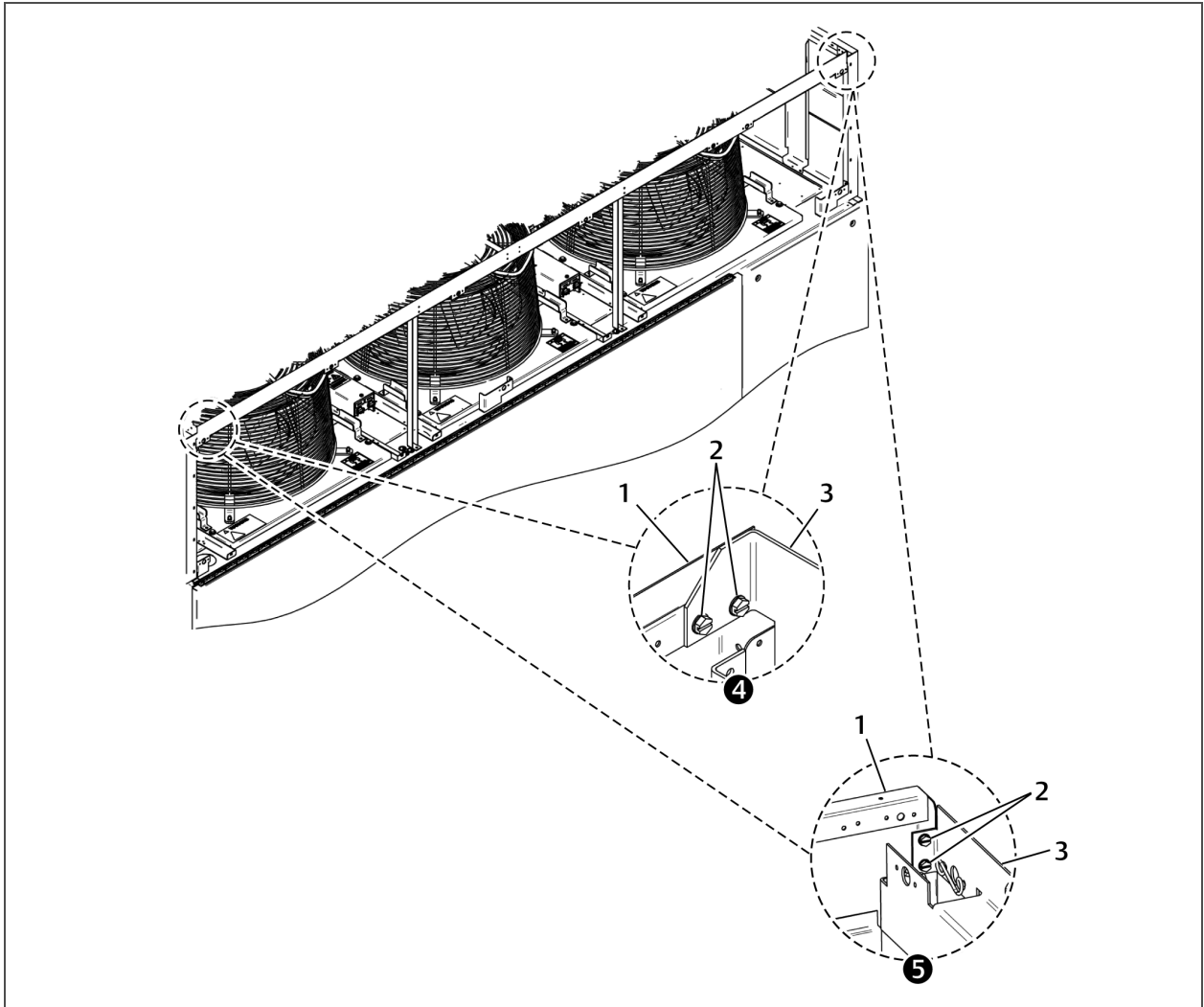

Item	Description
1	Side panel
2	Sheet-metal screws
3	Top frame
4	Attachment for non-grilled plenums. Shown from inside the plenum.
5	Attachment for rear-discharge plenum. Shown from inside the plenum.

4. Attach the bottom of the channel frame(s) to the top of the unit using 1 washer and 1 bolt for each, **Figure 6.19** below.

Figure 6.19 Channel frame bottom attachment

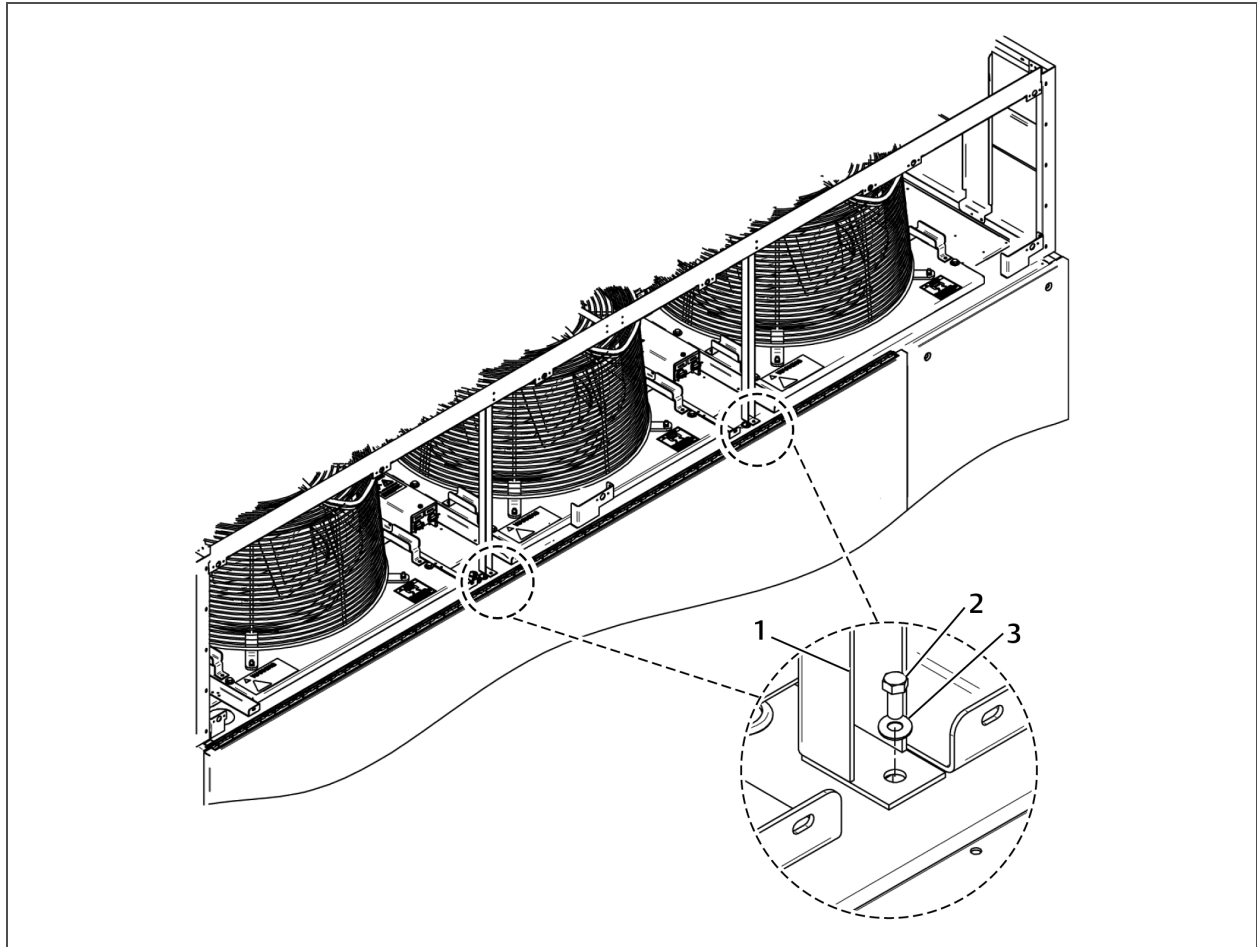

Item	Description
1	Channel frame
2	Bolt
3	Washer

- For non-grilled plenums, refer to **Figure 6.20** below, and attach the plenum brace to the top frame and the rear panel using 2 sheet-metal screws on each end.

Figure 6.20 Non-grilled plenum plenum-brace attachment

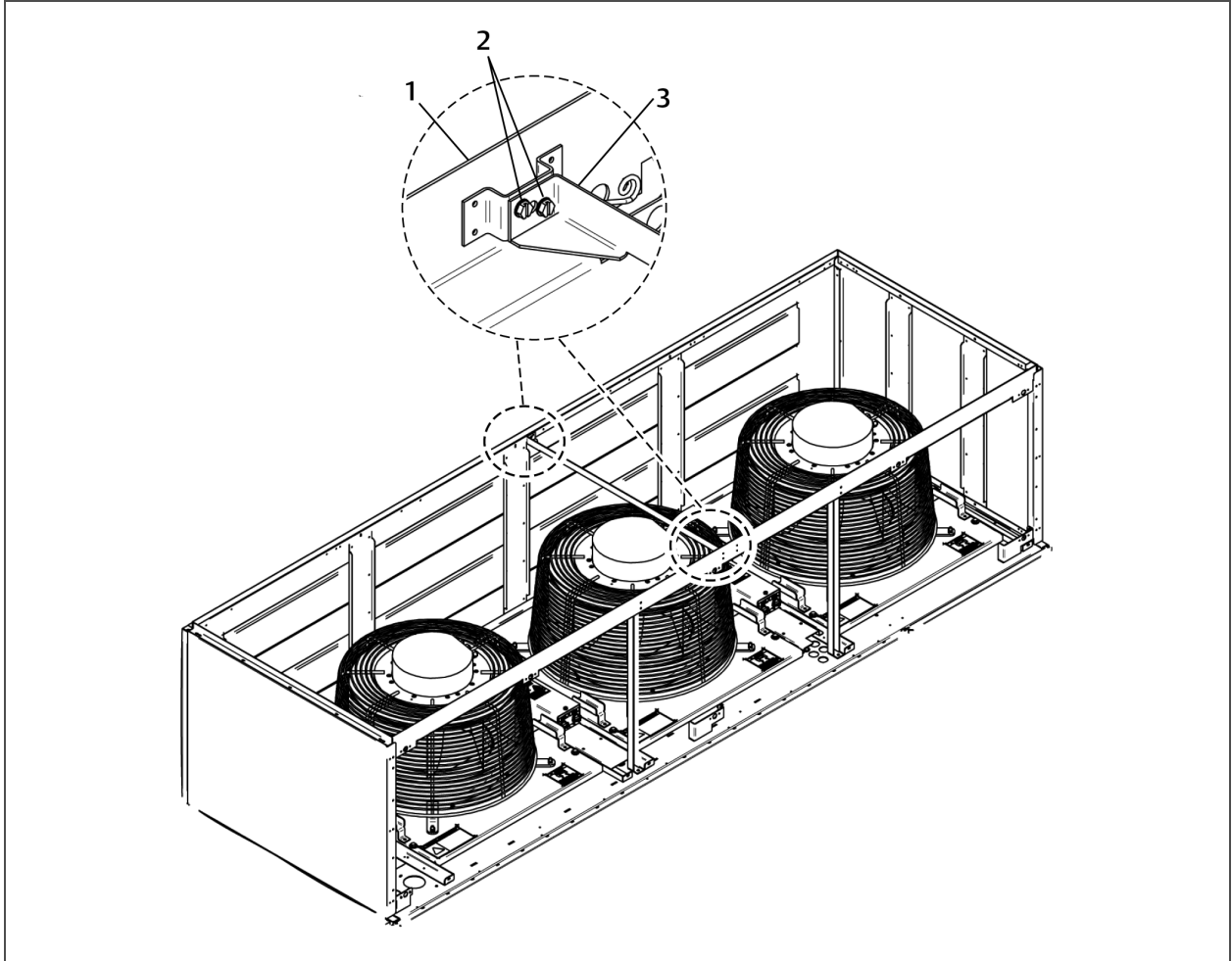

Item	Description
1	Top frame on front of plenum. Shown from inside.
2	Sheet-metal screws
3	Plenum brace

6. For non-grilled plenums, skip to step 7.

– or –

For rear-discharge plenums, assemble and attach the top panels:

- If a top-panel brace and plain top panel is included, attach them to the top panel with holes using 3 sheet-metal screws as shown in **Figure 6.21** below.
- Attach the top panel to the side and rear panels using 18 sheet-metal screws, **Figure 6.21** below.
- Attach the top panel to the top frame using 6 sheet-metal screws, **Figure 6.21** below.

Figure 6.21 Rear-discharge top-panel assembly and attachment

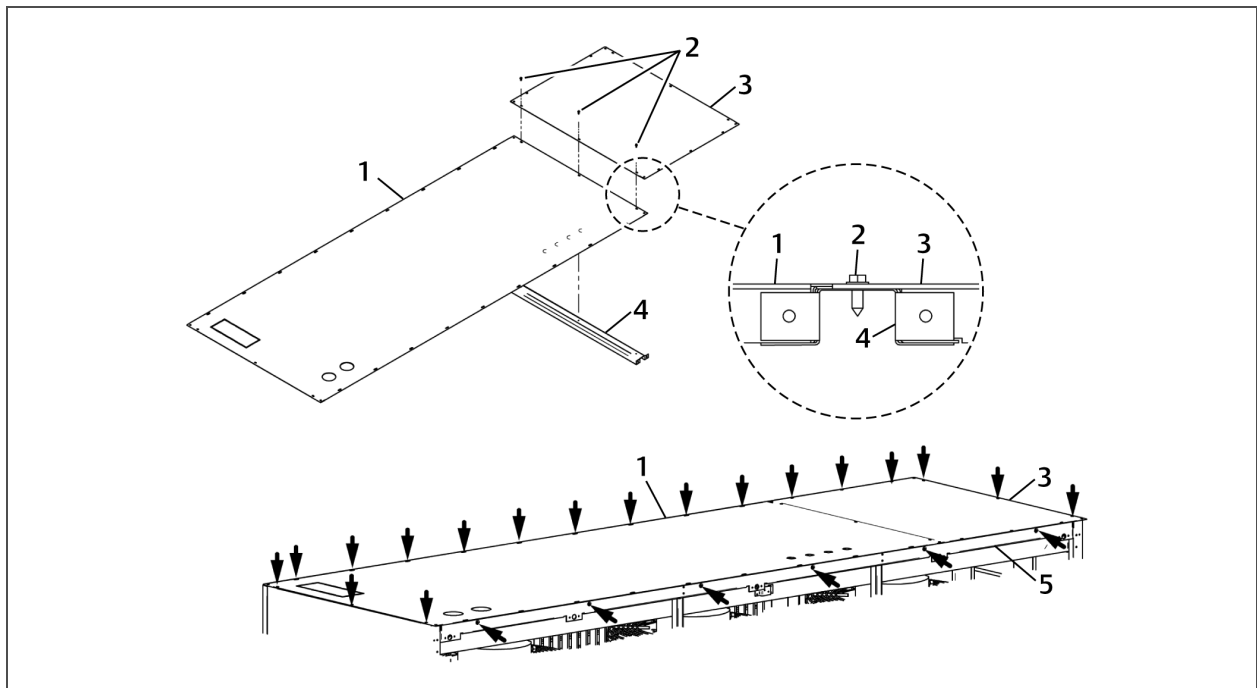

Item	Description
1	Top panel (with holes)
2	Sheet-metal screws
3	Top panel (plain)
4	Top-panel brace
5	Top frame

7. Attach the solid front panel using the quarter-turn fasteners in the panels, **Figure 6.22** below.

Figure 6.22 Front-panel attachment

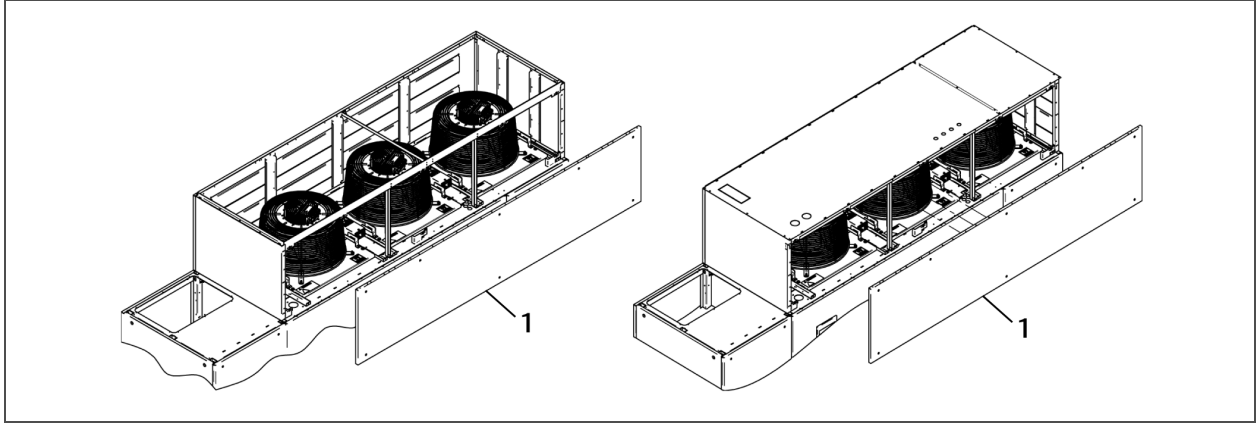

Item	Description
1	Front panel

Front-discharge front-panel assembly

1. Using the channel panel and 10 sheet-metal screws, attach the grilled front panel and the short, grilled front panel, **Figure 6.23** below.
2. Attach the assembled front panels to the plenum sides using 10 sheet-metal screws, 5 on each end.

Figure 6.23 Front-discharge front-panel attachment

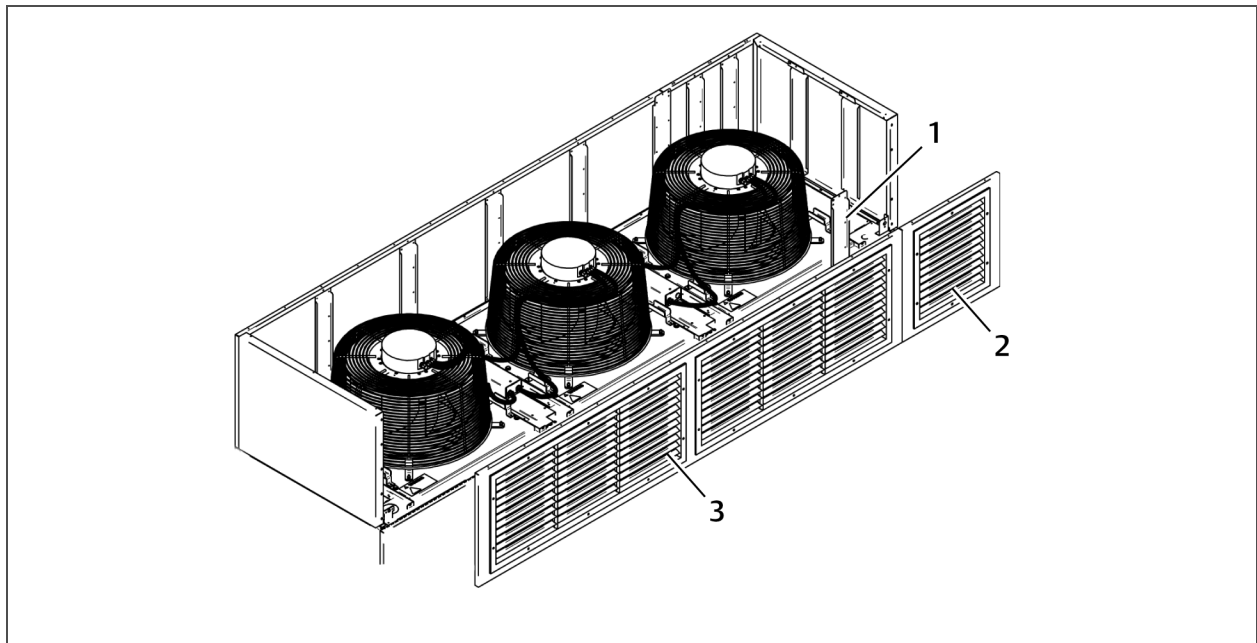

Item	Description
1	Channel panel
2	Short front panel
3	Front panel

3. Assemble and attach the top panels:
 - If a top-panel brace and plain top panel is included, attach them to the top panel with holes using 3 sheet-metal screws as shown in **Figure 6.23** on the previous page.
 - Attach the top panel and to top of the plenum assembly using 39 sheet-metal screws, **Figure 6.24** below.

Figure 6.24 Front-discharge top-panel assembly and attachment

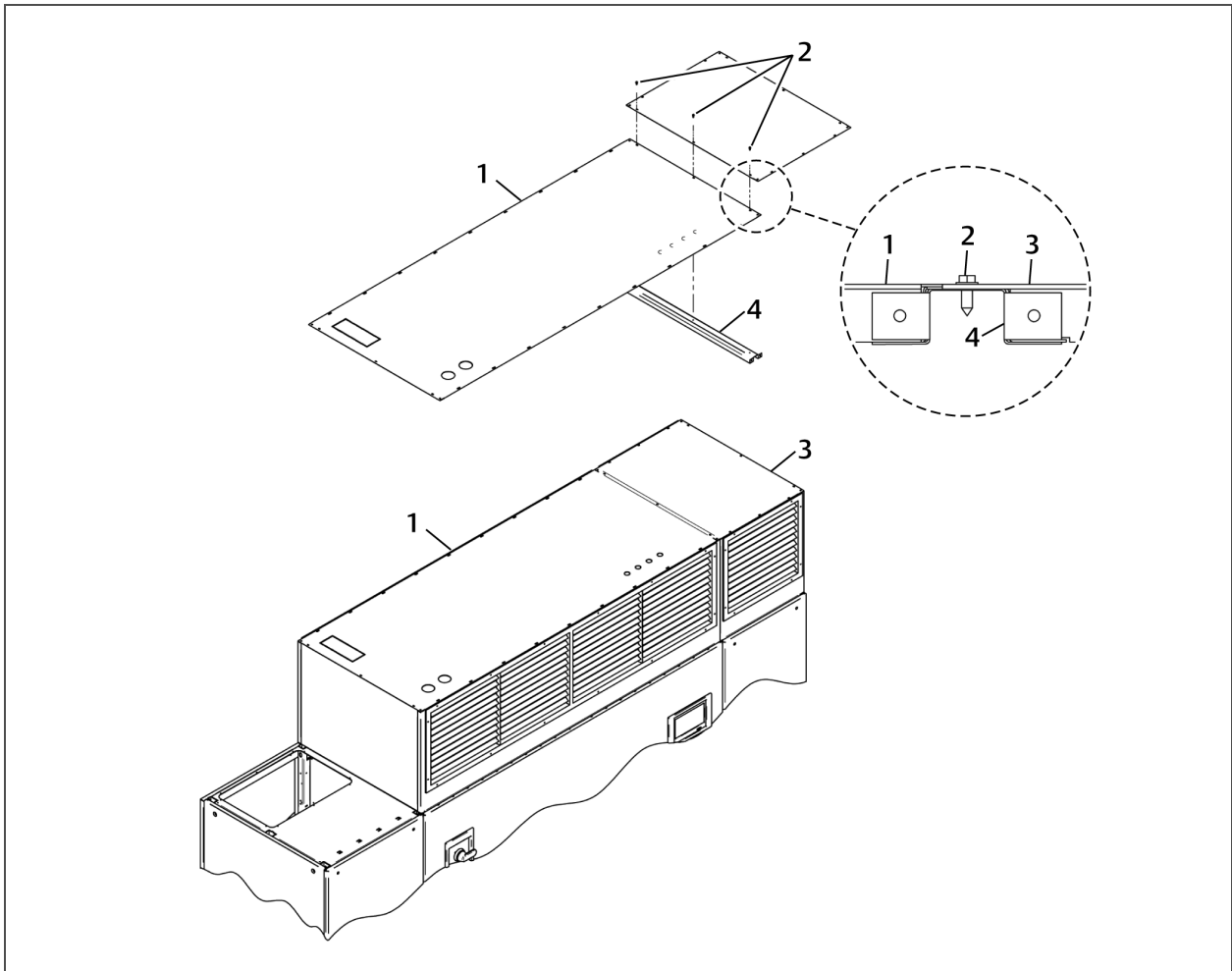

Item	Description
1	Top panel (with holes)
2	Sheet-metal screws
3	Top panel (plain)
4	Top-panel brace

6.3.5 Assemble and Install compressor-section plenum

If included and depending on the size of the unit, the width and depth of the plenum for the compressor section varies. For assembly purposes, the 26-in. (660-mm) wide plenum assembly procedure is slightly different than the other widths. For 13-in. (330-mm), 15-in. (381-mm), and 17-in. (432-mm) wide plenums, the assembly steps are identical.

NOTE: Provide a clearance area of 36 in. (914 mm) from bottom of unit to top of plenum for installation of plenum and component access.

1. For 26-in. plenum:

- Attach the side panel to the rear panel using 3 sheet-metal screws.
- Attach 1 angle-mounting channel to the side panel using 4 sheet-metal screws as shown in **Figure 6.25** on the next page.
- Attach 1 angle-mounting channel to the rear panel using 3 sheet-metal screws as shown in **Figure 6.25** on the next page.

– or –

For a 13-in., 15-in. or 17-in. plenum:

- Attach the front and rear panels to the side panel using 6 sheet-metal screws, 3 screws on each end.
- Attach an angle-mounting channel to the front and rear panels, as shown in **Figure 6.25** on the next page, using 3 sheet-metal screws on each channel.

Figure 6.25 Compressor-Plenum Assembly

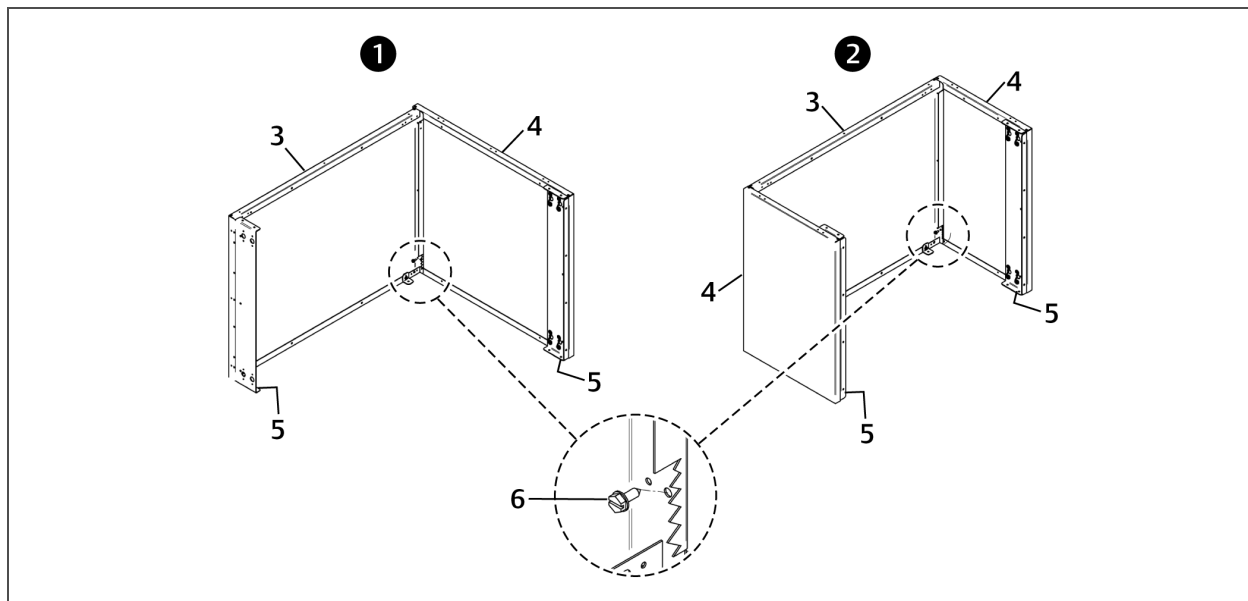

Item	Description
1	26-in. (600-mm) assembly
2	13-in. (330-mm), 15-in. (381 mm), 17-in. (432-mm) plenum assembly
3	Side panel
4	Front/Rear panel
5	Angle mounting channel
6	Sheet-metal screw

2. Place the assembled compressor plenum on the top of the unit, and attach the plenum to the unit using sheet-metal screws in the angle-mounting channel(s) and in angle brackets as shown in **Figure 6.26** below.
3. On 26-in. plenums only, attach the front panel using the quarter-turn fasteners in the panel, **Figure 6.26** below.

Figure 6.26 Compressor-Plenum Attachment

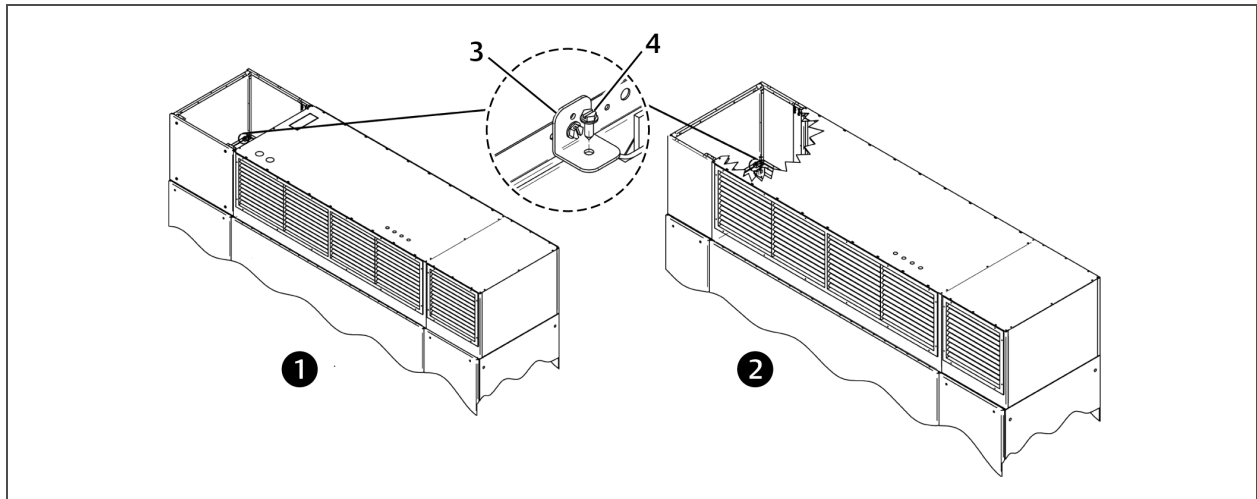

Item	Description
1	26-in. (600-mm) assembly
2	13-in. (330-mm), 15-in. (381 mm), 17-in. (432-mm) plenum assembly
3	Angle mounting bracket
4	Sheet-metal screw

This page intentionally left blank

7 CHECKLIST FOR COMPLETED INSTALLATION

7.1 Moving and Placing Equipment

1. Unpack and check received material.
2. Proper clearance for service access has been maintained around the equipment.
3. Equipment is level and mounting fasteners are tight.
4. If equipment has been disassembled for installation, unit must be reassembled per instructions.

7.2 Electrical Installation Checks

1. Supply voltage and phase matches equipment nameplate.
2. Power wiring connections completed to the disconnect switch, evaporator unit and heat rejection equipment.
3. Power line circuit breakers or fuses have proper ratings for equipment installed.
4. Control wiring connections completed between indoor evaporator and heat-rejection equipment.
5. All internal and external high- and low-voltage wiring connections are tight.
6. Confirm that unit is properly grounded to an earth ground.
7. Control transformer setting matches incoming power.
8. Electrical service conforms to national and local codes.
9. Check blowers and compressors for proper rotation.

7.3 Piping Installation Checks

1. Piping completed to refrigerant loop.
2. Piping has been leak-checked, evacuated and charged.
3. Additional oil has been added for system charges over 40 pounds (18.1kg) per circuit. See [Additional Oil Requirements for Scroll and Digital-scroll Compressors](#) on page 38.
4. Piping is properly sized, sloped and trapped as shown in the piping schematics.
5. Check piping inside and outside of equipment for proper support and adequate spacing to prevent rub-through.
6. Ensure that factory clamps have been reinstalled.
7. Drain line connected, not obstructed, and pitched per local code.
8. Water supply line connected to humidifier and not leaking.
9. Liebert® EconoPhase™ pumping unit has been correctly piped into the liquid line.

7.4 Other Installation Checks

1. Ducting or plenum assembly complete (if required), maintain access to filters.
2. On units with filter plenums, make sure filter-clog tubing is installed.
3. Filters installed.
4. Check fasteners that secure , reheats, humidifier and motors—some may have become loose during shipment.
5. Verify water detection is properly installed around all units (recommended).
6. Blower drive system rotates freely.
7. All fans are free of debris.
8. Remove rubber band from float in optional infrared humidifier.

9. Seal openings around piping and electrical connections.
10. Installation materials and tools have been removed from equipment (literature, shipping materials, construction materials, tools, etc.).
11. Locate blank start-up sheet, ready for completion by installer or start-up technician.

8 INITIAL START-UP CHECKS AND COMMISSIONING PROCEDURE FOR WARRANTY INSPECTION



WARNING! Arc flash and electric shock hazard. Open all local and remote electric power-supply disconnect switches, verify with a voltmeter that power is Off and wear appropriate, OSHA-approved personal protective equipment (PPE) per NFPA 70E before working within the electric control enclosure. Failure to comply can cause serious injury or death. Customer must provide earth ground to unit, per NEC, CEC and local codes, as applicable. Before proceeding with installation, read all instructions, verify that all the parts are included and check the nameplate to be sure the voltage matches available utility power. The Liebert® controller does not isolate power from the unit, even in the “Unit Off” mode. Some internal components require and receive power even during the “Unit Off” mode of the controller. The factory-supplied disconnect switch is inside the unit. The line side of this switch contains live high-voltage. The only way to ensure that there is NO voltage inside the unit is to install and open a remote disconnect switch. Refer to unit electrical schematic. Follow all local codes.



WARNING! Risk of improper wiring, piping, moving, lifting and handling. Can cause equipment damage, serious injury or death. Installation and service of this equipment should be done only by qualified personnel who have been specially-trained in the installation of air-conditioning equipment and who are wearing appropriate, OSHA-approved PPE.



CAUTION: Risk of smoke generation. Can cause fire suppression and alarm system activation, resulting in injury during building evacuation and mobilization of emergency fire and rescue services. Start-up operation of optional electric reheat elements can create smoke or fumes that can activate the facility alarm and fire suppression system. Prepare and take appropriate steps to manage this possibility. Activating reheat during initial start-up may burn off particulates from electric reheat elements. Before beginning initial start-up checks, make certain that unit was installed according to the instructions in this manual. All exterior panels must be in place.

NOTICE

Risk of improper electrical connection of three-phase input power. Can cause backward compressor rotation and unit damage. Service technicians should use a gauge set on the system during the initial start up to verify that the three-phase power is connected properly. The EC fans are not a reliable indicator of proper connection. The blowers will rotate the same direction, regardless of the three-phase power input. Three-phase power must be connected to the unit line voltage terminals in the proper sequence so that the compressors rotate in the proper direction. Incoming power must be properly phased to prevent compressors from running backward. We recommend checking the unit's phasing with proper instrumentation to ensure that power connections were made correctly. We also recommend verifying discharge and suction pressures during start up to ensure that the compressors are running in the correct direction.

- Confirm that all items on [Checklist for Completed Installation](#) on page 77 have been done.
- Locate “Liebert® DSE Warranty Inspection Check Sheet” in the unit’s electric panel.
- Complete “Liebert® DSE Warranty Inspection Check Sheet” during start-up.
- Forward the completed “Liebert® DSE Warranty Inspection Check Sheet” to your local sales office. **This information must be completed and forwarded to validate warranty.**
- Contact your local sales representative or technical support if you have any questions or problems during unit start-up and commissioning. Visit <https://www.Vertiv.com/en-us/support/> or call 1-800-543-2778 for contacts.

9 MAINTENANCE



WARNING! Arc flash and electric shock hazard. Open all local and remote electric power-supply disconnect switches, verify with a voltmeter that power is Off and wear appropriate, OSHA-approved personal protective equipment (PPE) per NFPA 70E before working within the electric control enclosure. Failure to comply can cause serious injury or death. Customer must provide earth ground to unit, per NEC, CEC and local codes, as applicable. Before proceeding with installation, read all instructions, verify that all the parts are included and check the nameplate to be sure the voltage matches available utility power. The Liebert® controller does not isolate power from the unit, even in the "Unit Off" mode. Some internal components require and receive power even during the "Unit Off" mode of the controller. The factory-supplied disconnect switch is inside the unit. The line side of this switch contains live high-voltage. The only way to ensure that there is NO voltage inside the unit is to install and open a remote disconnect switch. Refer to unit electrical schematic. Follow all local codes.



WARNING! Risk of electric shock. Can cause equipment damage, injury or death. Open all local and remote electric power supply disconnect switches and verify with a voltmeter that power is off before working within any electric connection enclosures. Service and maintenance work must be performed only by properly trained and qualified personnel and in accordance with applicable regulations and manufacturers' specifications. Opening or removing the covers to any equipment may expose personnel to lethal voltages within the unit even when it is apparently not operating and the input wiring is disconnected from the electrical source.



WARNING! Risk of improper wiring, piping, moving, lifting and handling. Can cause equipment damage, serious injury or death. Installation and service of this equipment should be done only by qualified personnel who have been specially-trained in the installation of air-conditioning equipment and who are wearing appropriate, OSHA-approved PPE.



WARNING! Risk of electric shock. Can cause serious injury or death. The Liebert® iCOM microprocessor does not isolate power from the unit, even in the "Unit Off" mode. Some internal components require and receive power even during the "unit off" mode of the Liebert® iCOM control. Open all local and remote electric power disconnect switches and verify with a voltmeter that power is Off before working on any component of the system.

The Liebert® DSE is a single component in the facility heat-removal system. The system includes air distribution (raised floors, duct systems), outdoor heat rejection (condensers, pumps) and indoor cooling and humidity loads (equipment load, location, outside air infiltration). Proper application and maintenance of the entire system is critical to the life and reliability of the thermal-management units.

- Good maintenance practices are essential to minimizing operation costs and maximizing product life.
- Read and follow monthly and semi-annual maintenance schedules included in this manual. These MINIMUM maintenance intervals may need to be more frequent based on site-specific conditions.
- See the Liebert®iCOM™ user manual, SL-31075, available at www.Vertiv.com, for instructions on using the controller to predict some service maintenance intervals.
- We recommend the use of trained and authorized service personnel, extended service contracts and factory-specified replacement parts. Contact your Vertiv sales representative.

9.1 Filters

NOTICE

Risk of improper filter installation. Can cause filter collapse and airflow reduction.

Pleat direction is non-standard. Use only short-pleat filters (see **Figure 9.2** on page 84). Long-pleat filters are subject to collapse at high airflows.

To maximize the performance and reliability of the equipment, use only Vertiv filters. Contact your Vertiv representative to order replacement filters.

Verify that filters are installed and positioned so the air-flow direction marked on the filter is the same direction as unit air flow.

Table 9.1 Filter Quantities

Unit Size	Filter Size, Width x Length	Number of Filters	
		4 in. Filter Option, MERV 8, MERV 11 or MERV 13	2-in. Primary/2-in. Pre-filter option, Merv 11 Primary/MERV 8 Pre-filter or MerV 13 Primary/MERV 8 Pre-Filter
DA050	25 x 16	1	1/1
	25 x 20	2	2/2
DA080/085 Downflow	25 x 20	4	4/4
DA080/085 Upflow	25 x 20	6	6/6
DA125/150	21.5 x 24	10	10/10
DA165	21.5 x 24	10	10/10

9.1.1 Filter-replacement for Downflow Units

1. Disconnect power from the unit.
2. Open the front access panel, locate the filter above the electric panel, and slide the filter out the front of the unit.
3. Replace with new filter—install the filter in the proper direction of the airflow.
4. Test the operation of the filter clog switch.
The unit panels must be in place and closed to find this point.

5. Start the blower and turn the switch counterclockwise until the alarm is energized.
6. Turn the adjusting knob one turn clockwise or to the desired filter change point.

Figure 9.1 Proper filter pleat direction

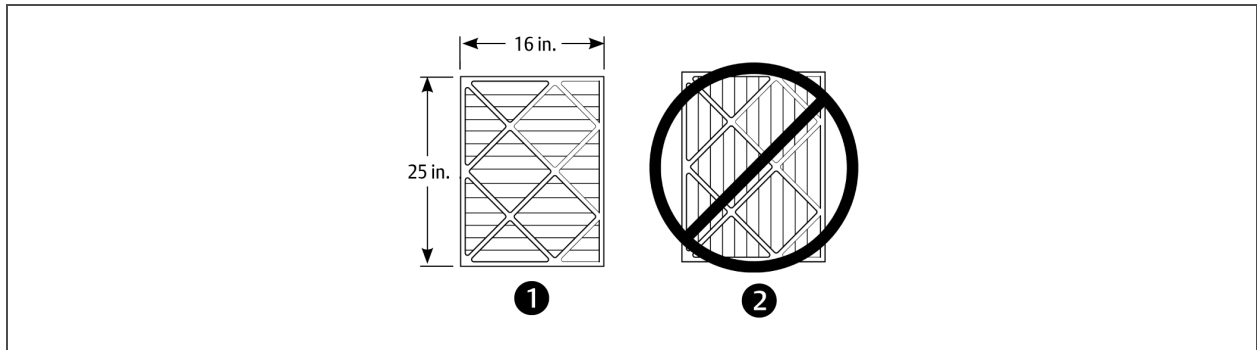

Item	Description
1	Short pleat construction
2	Long pleat construction

9.1.2 Filter-replacement for Upflow Units

1. Disconnect power from the unit.
2. Open the front access panel and remove the filter(s).
 - For upflow front return units, remove the lower front access panels, lift filters to the top of the filter rack and tilt forward for removal.
 - For upflow rear return units, remove filters using filter access door in rear return filter box.
3. Replace with new filter—install the filters in the proper direction of the airflow. The proper direction is marked on the filter.
4. Test the operation of the filter clog switch.
The unit panels must be in place and closed to find this point.

5. Start the blower and turn the switch counterclockwise until the alarm is energized.
6. Turn the adjusting knob one turn clockwise or to the desired filter change point.

Figure 9.2 Proper filter pleat direction

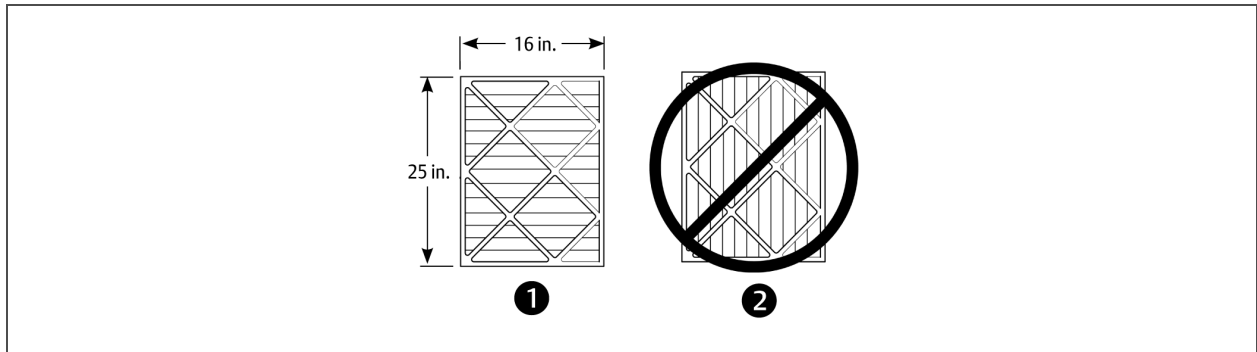

Item	Description
1	Short pleat construction
2	Long pleat construction

9.2 Blower Drive System—EC Fans



WARNING! Risk of electric shock. Can cause serious injury or death. Open all local and remote electric power supply disconnect switches and verify with a voltmeter that power is off before working within the fan-motor electric-connection enclosures. Fan-motor controls can maintain an electric charge for 10 minutes after power is disconnected. Wait 10 minutes after power is verified as off before working within the fan electric control/connection enclosures. Use only fully-trained and qualified HVAC technicians to perform maintenance on the fans.



CAUTION: Risk of contact with hot surfaces. Can cause injury. The electronics housing, humidifier components, compressor, refrigerant discharge lines, fan motor, and some electrical components are extremely hot during unit operation. Allow sufficient time for them to cool to a touch-safe temperature before working within the unit cabinet. Use extreme caution and wear appropriate, OSHA-approved PPE when working on or near hot components.



CAUTION: Risk of improper moving, lifting and handling. Can cause equipment damage or injury. Only properly trained and qualified personnel should work on this equipment. Evaporator fan modules weigh in excess of 125-lb (56.7-kg). Use proper lifting techniques and wear appropriate, OSHA-approved PPE to avoid injury and dropping the fan module during removal. Equipment used in handling/lifting, and/or installing the fan assembly must meet OSHA requirements. Use handling/lifting equipment rated for the weight of the fan assembly. Use ladders rated for the weight of the fan assembly and technicians if used during installation. Refer to handling/lifting, and/or installation equipment operating manual for manufacturer's safety requirements and operating procedures.

NOTICE

Risk of improper power-supply connection. Can cause equipment damage and loss of warranty coverage.

Prior to connecting any equipment to a main or alternate power source (for example: back-up generator systems) for start-up, commissioning, testing, or normal operation, ensure that these sources are correctly adjusted to the nameplate voltage and frequency of all equipment to be connected. In general, power-source voltages should be stabilized and regulated to within $\pm 10\%$ of the load nameplate nominal voltage. Also, ensure that no three-phase sources are single-phased at any time.

NOTICE

Risk of improper installation. Can cause equipment damage.

Only a properly trained and qualified technician should install or open this motor.

Use 60/75°C Class 1 copper wire only.

9.2.1 Protective Features

Monitoring functions protect the motor against overtemperature of electronics, overtemperature of motor and incorrect rotor position detection. With any of these failures, an alarm will display through the Liebert® iCOM controller and the motor stops electronically. There is no automatic restart. The power must be switched off for a minimum of 20 seconds once the motor is at a standstill.

The motor also provides locked rotor protection, undervoltage/phase failure detection and motor current limitation. These conditions will display an alarm through the Liebert® iCOM.

9.2.2 Fan Impellers and Bearings Maintenance

Fan impellers should be periodically inspected and any debris removed. Check to ensure that the impellers can rotate freely and that the fan guards are still properly mounted for sufficient protection against accidentally contacting the impeller. Bearings used on the units are maintenance-free. Consult the factory for more information.

9.2.3 Fan Assembly Troubleshooting

Any safety hazards stemming from the device must be re-evaluated once it is installed in the end device.

Do not make any modifications, additions or conversions to the fan assembly without the approval of Vertiv.



WARNING! Risk of electric shock. Can cause serious injury or death. Open all local and remote electric power-supply disconnect switches and verify with a voltmeter that power is off before opening the fan motor electric-connection enclosure. Use only fully-trained and qualified HVAC technicians to replace or perform maintenance on the EC fans.



WARNING! Risk of contact with high-speed rotating fan blades. Can cause serious injury or death. Open all local and remote electric power-supply disconnect switches, verify with a voltmeter that power is off, and verify that all fan blades have stopped rotating before working in the unit cabinet or on the fan assembly. If control voltage is applied, the fan motor can restart without warning after a power failure. Do not operate the unit with any or all cabinet panels removed.



CAUTION: Risk of exposure to harmful noise levels. Can cause hearing injury or loss. Depending on the installation and operating conditions, a sound pressure level greater than 70 dB(A) may arise. Take appropriate technical safety measures. Operating personnel must wear appropriate, OSHA-approved PPE and observe all appropriate hearing-protection safety requirements.



CAUTION: Risk of contact with hot surfaces. Can cause injury. The fan motor, and some electrical components are extremely hot during unit operation. Allow sufficient time for them to cool to a touch-safe temperature before working within the unit cabinet. Use extreme caution and wear appropriate, OSHA-approved PPE when working on or near hot components.

NOTICE

Risk of improper power-supply connection. Can cause equipment damage and loss of warranty coverage.

Prior to connecting any equipment to a main or alternate power source (for example: back-up generator systems) for start-up, commissioning, testing, or normal operation, ensure that these sources are correctly adjusted to the nameplate voltage and frequency of all equipment to be connected. In general, power-source voltages should be stabilized and regulated to within $\pm 10\%$ of the load nameplate nominal voltage. Also, ensure that no three-phase sources are single-phased at any time.

NOTE: Do not assume that the fan blades will not start to spin. If the motor is in a fault condition, it will safely shut down. Once the fault condition is cleared, there are certain conditions in which the motor will automatically resume operation.

EC-fan Fault Conditions

Table 9.2 EC-fan Fault Conditions

Fault Condition	Reset Trigger	Description
Phase Failure	Automatic	One phase is missing. In this case the motor will come to a stop and then automatically restart when all phases are present.
Locked/Blocked Rotor	Automatic	The rotor is blocked. Once the locking mechanism has been removed, the motor will automatically restart.
Hall Effect Sensor Error	Manual (Mains/Software)	The Hall Effect Sensor is used to monitor fan speed. If there is a hall sensor communication failure with the electronics, the motor will stop. In this case there has to be a manual restart (either with the mains power or software).
Motor Over Temperature	Manual (Mains/Software)	The motor will stop in the event there is a motor over temperature condition. In this case there has to be a manual restart (either with the mains power or software).
Electronics Over Temperature	Manual (Mains/Software)	The motor will stop in the event there is an electronics over temperature condition. In this case there has to be a manual restart (either with the mains power or software).
Line Under-Voltage	Automatic	Once the line voltage returns within permitted operating range, the fan will automatically restart.

EC-fan High-voltage Tests

1. Check Fuses. If fuses are okay, perform the following:
 - Check all connections.
 - Make sure connections are on the wire strand and not on the wire insulation.
 - Cycle Power. Disconnect mains voltage to power down the motor and then re-apply power.
 - Check mains voltage at each phase (phase to ground) at the KL1 connector. Confirm phase failure not present.
 - Check that the voltage is within the acceptable voltage range at the KL1 connector. Confirm line under-voltage is not present.

2. Check Fuses. If fuses are blown, perform the following:

- Check resistances across the phases at the KL1 connector and note them in the following table..

NOTE: Power wires must be removed from the motor for resistance test.

L1 - L2		Ohm
L2 - L3		Ohm
L1 - L3		Ohm

- Resistances should be similar for all 3 readings.
- Resistance readings should be greater than 2 Ohm.
 - Check all connections. Make sure connections are on the wire strand and not on the wire insulation.
 - Replace Fuses.
 - Check mains voltage at each phase (phase to ground) at the KL1 connector. Confirms phase failure not present.

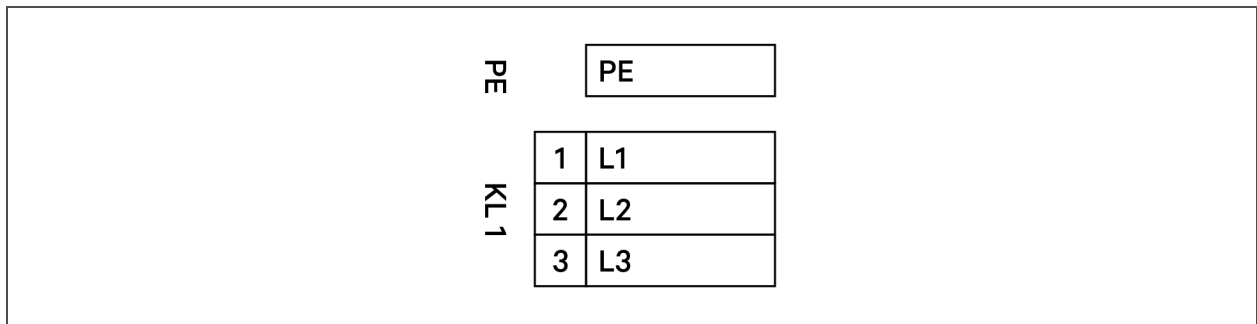

- Check that the voltage is within the acceptable voltage range at the KL1 connector. Confirms line under-voltage is not present.

EC-fan Low-voltage Tests

- Check control input at the KL3 connector (Ain1U to GND). Confirm that there is a control voltage present at the KL3 connector.

NOTE: Use the GND in the KL3 connector. Do not connect the control ground to the PE in KL1!

- Check +10 V output on KL3 connector (between +10 V and GND).

KL3	1	RSA		8	OR	KL3	1	RSA	Din 2	8
	2	RSB	+10V	9			2	RSB	Din 3	9
	3	GND	Ain 1 U	10			3	GND	GND	10
	4			11			4	Ain 1 U	Ain 2 U	11
	5			12			5	+ 10 V	+ 20 V	12
	6			13			6	Ain 1 I	Ain 2 I	13
	7			14			7	Din 1	Aout	14

EC-fan Alarm Contact Tests

Check the alarm contact at KL2 to determine if there are any fault conditions present.

KL2	1	NO
	2	COM
	3	NC

Condition	No Fault Condition	Fault Condition
NO - COM	Open	Closed
NC - COM	Closed	Open

NOTE: The table refers to conditions while the motor is actively energized. When the motor is de-energized, it will be in a fault condition.

- Check EC Control to determine the fault condition.

9.2.4 Removing EC Fans from Downflow Units

The EC fans in Liebert® DSE units can be removed for easier maintenance or for replacement.



WARNING! Risk of electric shock. Can cause serious injury or death. Open all local and remote electric power supply disconnect switches and verify with a voltmeter that power is off before working within the fan-motor electric-connection enclosures. Fan-motor controls can maintain an electric charge for 10 minutes after power is disconnected. Wait 10 minutes after power is verified as off before working within the fan electric control/connection enclosures. Use only fully-trained and qualified HVAC technicians to perform maintenance on the fans.



WARNING! Risk of contact with high-speed rotating fan blades. Can cause serious injury or death. Open all local and remote electric power-supply disconnect switches, verify with a voltmeter that power is off, and verify that all fan blades have stopped rotating before working in the unit cabinet or on the fan assembly. If control voltage is applied, the fan motor can restart without warning after a power failure. Do not operate the unit with any or all cabinet panels removed.



WARNING! Risk of extremely heavy fan modules dropping downward suddenly. Can cause injury or death. Fan modules weigh in excess of 125-lb (56.7-kg) each. Support fan modules before removing mounting hardware. Use caution to keep body parts out of fan module pathway of movement during removal. Only properly trained and qualified personnel should work on this equipment.

Read these instructions and unit labeling before removing fan modules. The instructions show a Liebert® DSE with a 24-in. floor stand. Your unit may look slightly different.

Hardware and Tools Required

- 1/2" hex socket and wrench
- Factory-supplied jack, crank and jack support
- Cable tie cutter
- Field-supplied fan removal device capable of supporting fan assembly weight

To remove an EC fan module:

1. Remove panels from the front of the unit.
2. Remove the humidifier pan. You can remove fans without removing the humidifier pan, but removing it makes fan removal easier, see **Figure 9.3** on the facing page.

Figure 9.3 Humidifier pan removal

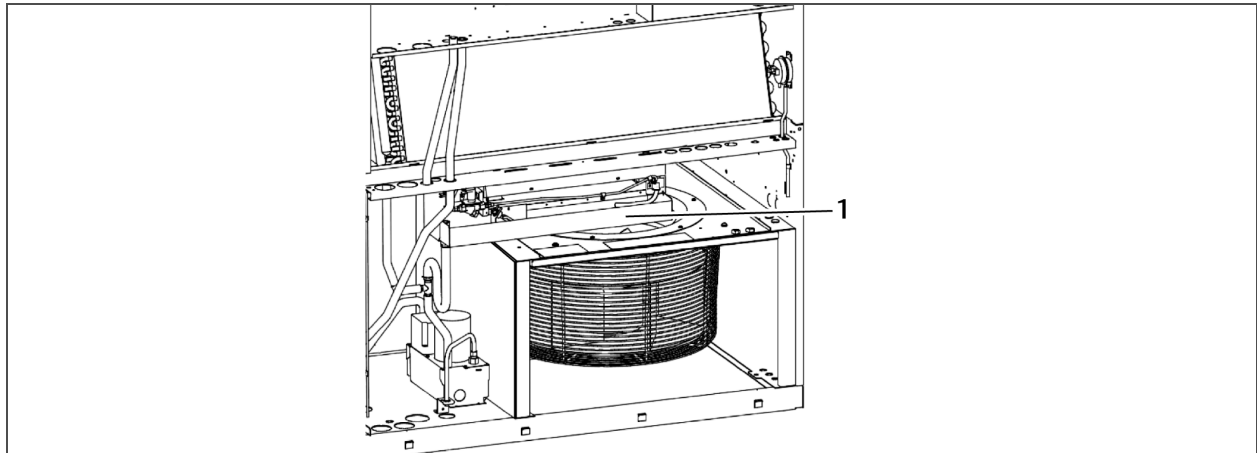

Item	Description
1	Humidifier pan

3. If the fan module is raised and in the unit, proceed to step 6.
– or –

If the fan module is lowered into the floor stand, refer to **Figure 9.4** below and before removing any hardware, center the factory-supplied jack between the tabs on the jack support.

Figure 9.4 Jack placement to support EC fan module

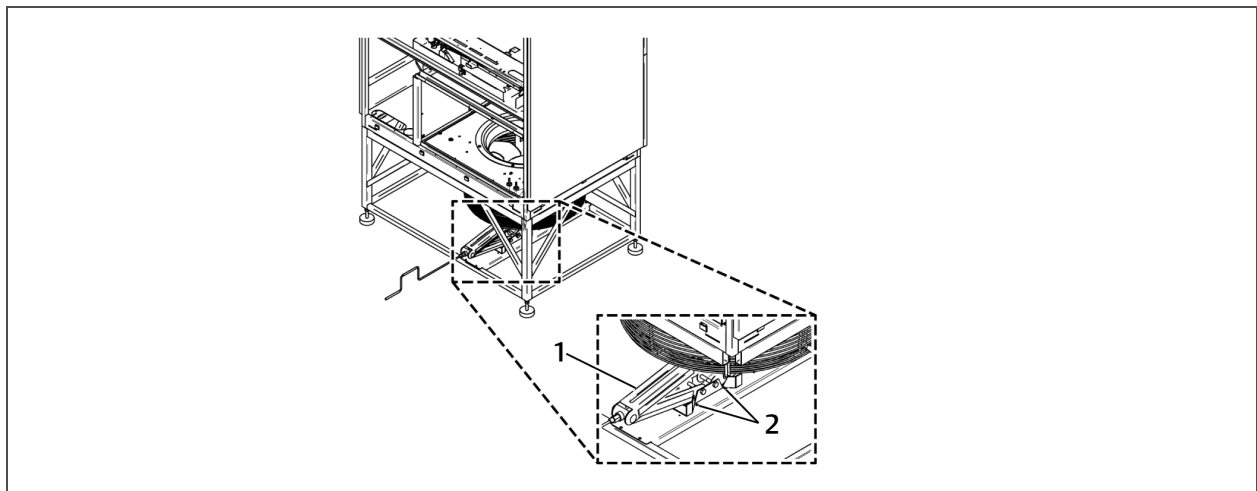

Item	Description
1	Position jack to support fan
2	Tabs

- Remove hardware, **Figure 9.5** below, that retains the fan in the lowered position, and save it for re-installation.

NOTE: Hardware quantity and location varies depending on the type of unit.

Figure 9.5 Hardware removal

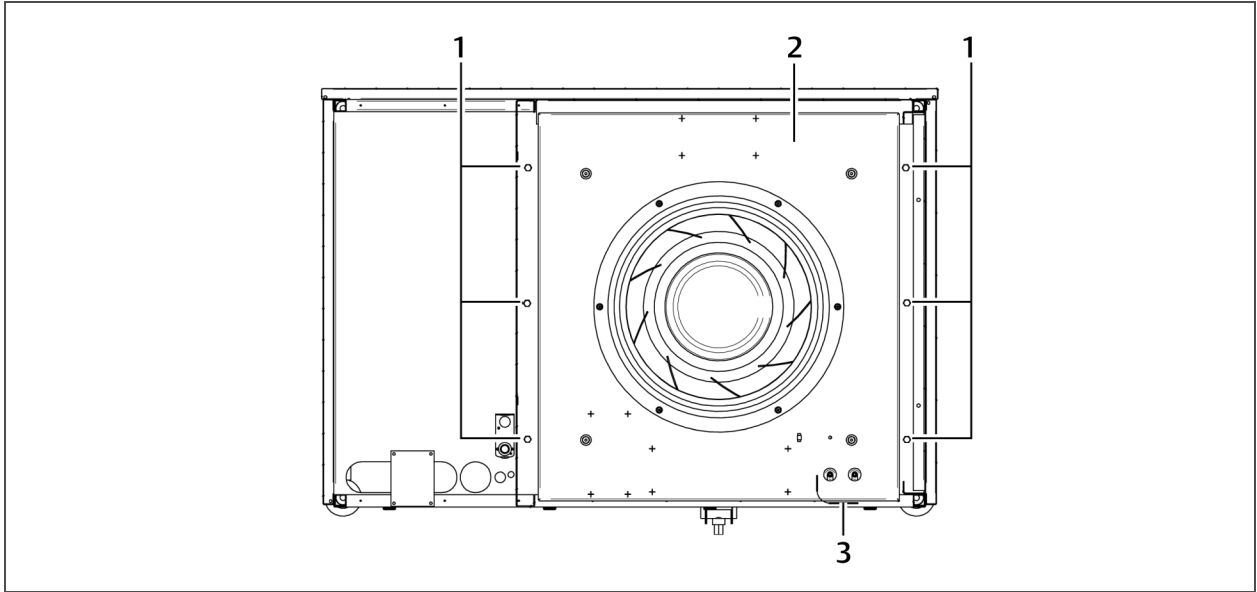

Item	Description
1	1/2-in. (13-mm) Hex-head bolts (typical both sides)
2	Fan deck
3	Wiring loop

- Use the jack to raise the fan module slowly until the fan motor clears the front frame channel.
- Insert a field-supplied fan-removal device securely on the front and rear frame channels under the fan module as shown in **Figure 9.6** on the facing page.
 - A suitable fan-removal device is two lengths of rigid material that is 4 inches (100 mm) wide and strong enough to support the weight of the fan module.

7. Disconnect high-voltage and low-voltage fan-motor wiring from the fan-motor electric component inside the electric panel. Cut cable ties as needed.
8. Using the removal device shown inserted in **Figure 9.6** below, slide the fan module out through the front of the unit.
9. To reinstall the fan module, reverse these steps. Remove the field-supplied fan-removal device before resuming operation.

NOTE: Refer to the unit's electrical schematic for specific wire-attachment points.

Figure 9.6 Slide EC fan out of the unit

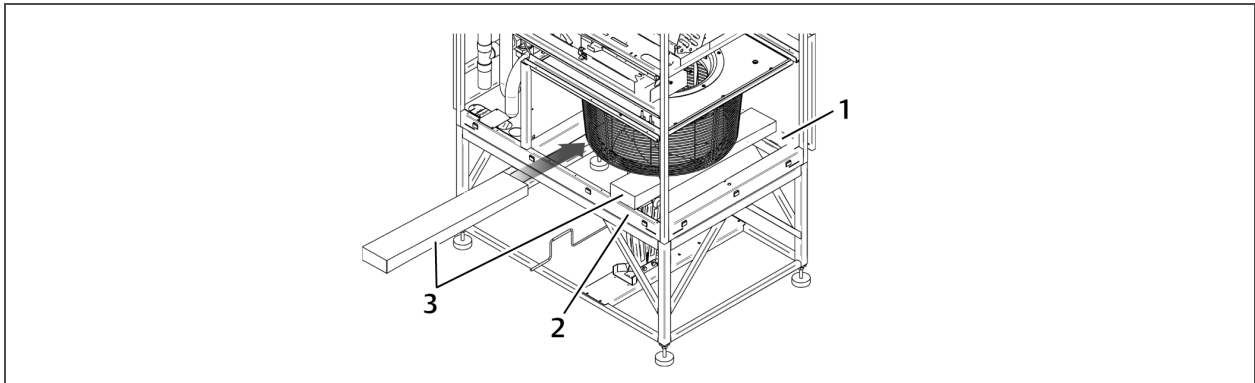

Item	Description
1	Rear frame channel (right-side panel not shown)
2	Front channel
3	Fan-removal devices

9.2.5 Removing EC Fans from Upflow Units



WARNING! Risk of electric shock. Can cause serious injury or death. Open all local and remote electric power supply disconnect switches and verify with a voltmeter that power is off before working within the fan-motor electric-connection enclosures. Fan-motor controls can maintain an electric charge for 10 minutes after power is disconnected. Wait 10 minutes after power is verified as off before working within the fan electric control/connection enclosures. Use only fully-trained and qualified HVAC technicians to perform maintenance on the fans.



WARNING! Risk of contact with high-speed rotating fan blades. Can cause serious injury or death. Open all local and remote electric power-supply disconnect switches, verify with a voltmeter that power is off, and verify that all fan blades have stopped rotating before working in the unit cabinet or on the fan assembly. If control voltage is applied, the fan motor can restart without warning after a power failure. Do not operate the unit with any or all cabinet panels removed.



WARNING! Risk of extremely heavy fan modules dropping downward suddenly. Can cause injury or death. Fan modules weigh in excess of 125-lb (56.7-kg) each. Support fan modules before removing mounting hardware. Use caution to keep body parts out of fan module pathway of movement during removal. Only properly trained and qualified personnel should work on this equipment. More than one person may be required to complete the assembly and installation. Installer(s) must be properly trained and qualified to lift, move and manipulate very heavy equipment from floor level to the top of the unit. Wear appropriate, OSHA-approved PPE when moving, lifting, installing, and removing the fan(s) and plenum. Read and follow the lifting equipment and/or ladder manufacturer's operating instructions and safety requirements.

NOTE: We recommend using a duct lift or scissors lift when installing or removing the EC-fan assemblies on top of the unit.

1. Disconnect the black-sleeved low-voltage harness and the green-sleeved high-voltage harness from the junction box, **Figure 9.7** below.

Figure 9.7 EC-fan junction boxes

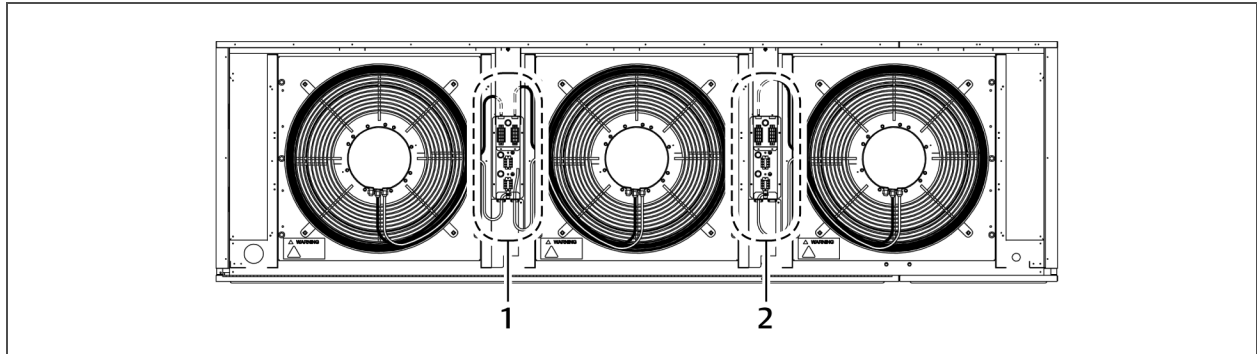

Item	Description
1	Junction box between fans 1 and 2 on 2- and 3-fan unit
2	Junction box for 1- or 3-fan unit

2. Locate the 6 places where the EC-fan assembly attaches to the unit, **Figure 9.8** below, and remove the bolts, washers and spacers, **Figure 9.9** on the next page.

Figure 9.8 Assembly in place on the unit

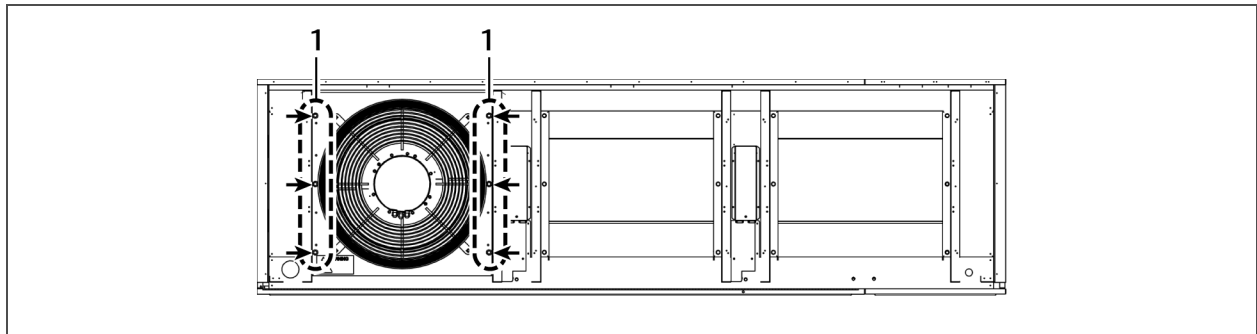

Item	Description
1	Mounting holes

Figure 9.9 Bolts, washers and spacers on EC-fan assembly (6 places)

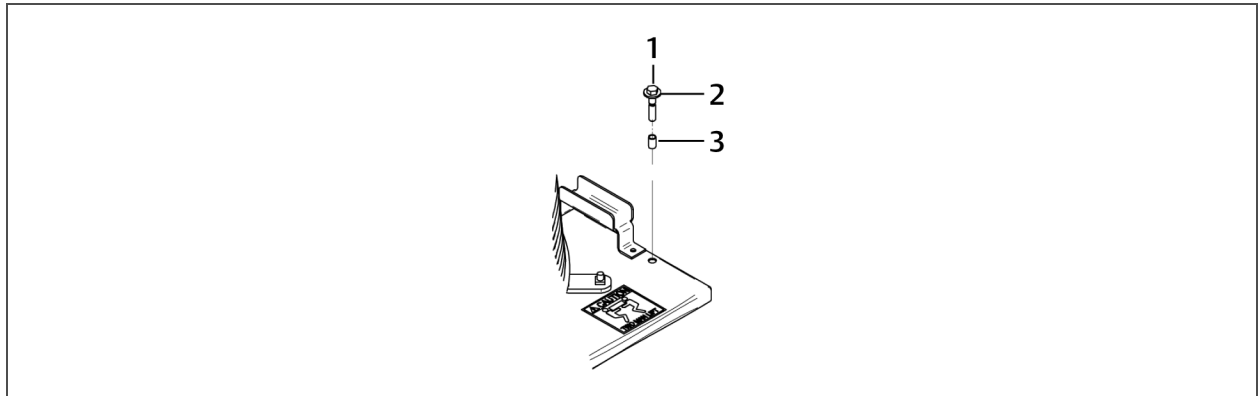

Item	Description
1	Bolt
2	Washer
3	Spacer

3. Position the lifting device so that it lines-up with the EC-fan assembly.

NOTE: A minimum clearance of 36 in. (914 mm) from the bottom of the unit to the top of the plenum is required for component access.

4. Using the handles on the EC-fan assembly, carefully lift the assembly over the hinge along the top of the unit, and slide the assembly onto the lifting device, **Figure 9.10** below.
5. Use the lifting device to lower the EC-fan assembly for transport to service or maintenance area.

Figure 9.10 EC-fan assembly moved onto lifting device

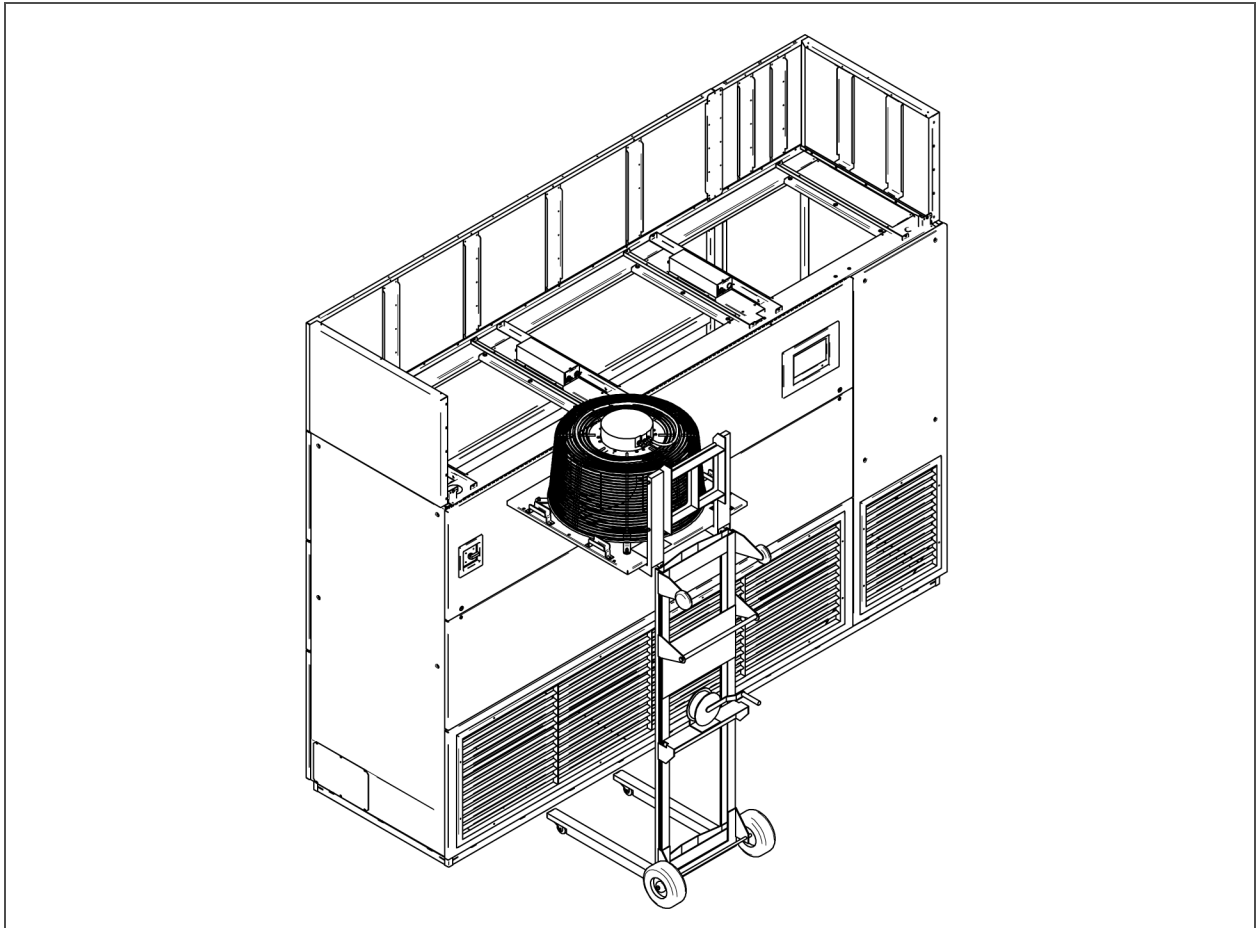

9.3 Infrared Humidifier Maintenance

During normal humidifier operation, deposits of mineral solids will collect in humidifier pan and on the float switch. These must be cleaned periodically to ensure proper operation. Frequency of cleaning must be locally established since it is dependent on humidifier usage and local water quality. A spare pan is recommended to reduce maintenance time at unit. The Liebert® autoflush system can greatly increase the time between cleanings, but does not eliminate the need for periodic checks and maintenance (see Liebert® iCOM™ user manual SL-31075 for autoflush setup). To help reduce excessive scaling in locations with difficult water quality, the use of Vapure™ is recommended (contact your local sales representative).



WARNING! Arc flash and electric shock hazard. Open all local and remote electric power-supply disconnect switches, verify with a voltmeter that power is Off and wear appropriate, OSHA-approved personal protective equipment (PPE) per NFPA 70E before working within the electric control enclosure. Failure to comply can cause serious injury or death. Customer must provide earth ground to unit, per NEC, CEC and local codes, as applicable. Before proceeding with installation, read all instructions, verify that all the parts are included and check the nameplate to be sure the voltage matches available utility power. The Liebert® controller does not isolate power from the unit, even in the “Unit Off” mode. Some internal components require and receive power even during the “Unit Off” mode of the controller. The factory-supplied disconnect switch is inside the unit. The line side of this switch contains live high-voltage. The only way to ensure that there is NO voltage inside the unit is to install and open a remote disconnect switch. Refer to unit electrical schematic. Follow all local codes.



CAUTION: Risk of contact with extremely hot water and part surfaces. Can cause burn injury. The infrared humidifier bulbs, metal enclosure, humidifier water, water reservoir pan and drain tubing are very hot during and shortly after operation. Allow sufficient time for these parts to cool to a touch-safe temperature before handling. Use extreme caution, and wear appropriate, OSHA-approved PPE when performing maintenance on the infrared humidifier.

9.3.1 Cleaning Humidifier Pan and Float Switch

Before turning the unit Off:

1. With unit operating, remove call for humidification at the Liebert® iCOM control.
2. Let the blower operate 5 minutes to allow the humidifier and water to cool.
3. If unit has a condensate pump, turn unit OFF at Liebert® iCOM control.
4. Pull out the humidifier standpipe in pan.
5. Inspect the O-ring (replace if necessary).
6. Let the pan drain and condensate pump operate (if applicable).
7. Disconnect power from the unit.
8. Disconnect the drain coupling from the bottom of the pan.
9. Remove the thermostat from the bottom of the pan and the retaining screws from the sides of the pan.
10. Slide the pan out.
11. Loosen scale on side and bottom of pan with a stiff nylon brush or plastic scraper.
12. Flush with water.
13. Carefully clean scale off float switch (make sure to reinstall correctly (see **Figure 9.11** on the facing page).

14. Reinstall the pan, thermostat, standpipe, drain coupling and screws into the humidifier.
15. Operate the humidifier and check for leaks.

Figure 9.11 Correct float switch orientation

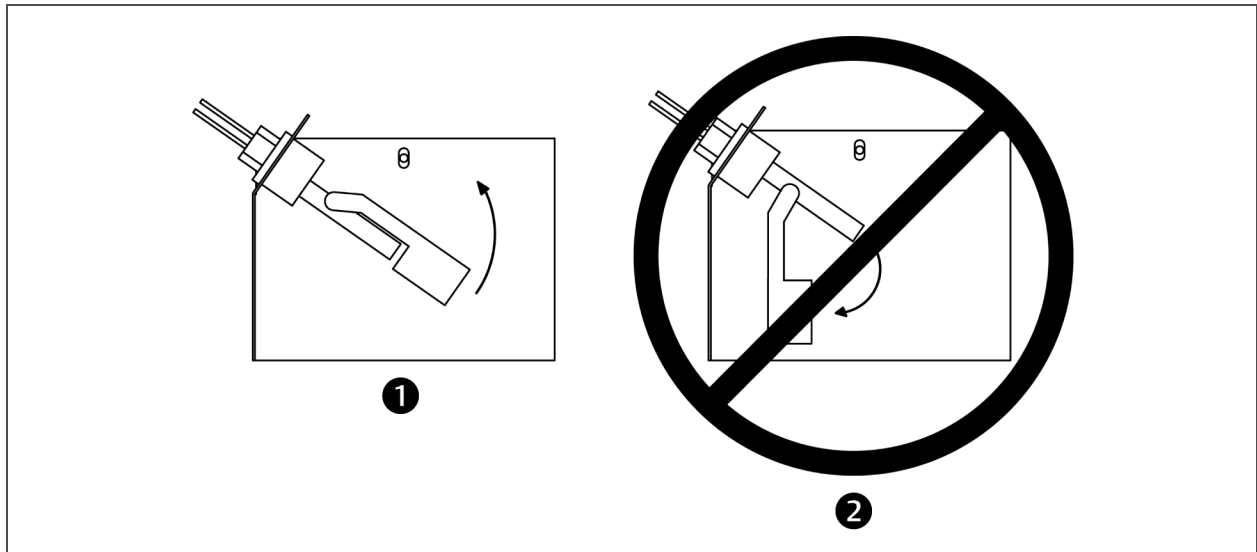

Item	Description
1	Correct switch orientation
2	Incorrect switch orientation

9.3.2 Changing Humidifier Lamps

NOTE: Touching quartz lamps with bare hands will severely shorten bulb life. Skin oils create hot spots on lamp surface. Wear clean cotton gloves when handling lamps.

The lamps are shown in **Figure 9.12** on the next page.

1. Remove humidifier pan (see [Cleaning Humidifier Pan and Float Switch](#) on the previous page, steps 1 through 10).
2. Disconnect power from unit.
3. At humidifier, remove screws and cover from high-voltage compartment.
4. Disconnect one end of purple jumper wires.
5. Using a continuity meter, locate burned out lamp.
6. Remove lamp brackets under lamps.
7. Loosen two screws securing lamp lead wires to junction block.
8. Pull bulb straight down and discard.
9. Wrap lead wires once around new lamp's metal ends. This will support lamp and allow for thermal expansion. Insert lead wires into junction block and torque screws to 30 in-lb.
10. Reassemble by reversing steps 1 through 9.

Figure 9.12 Infrared humidifier lamps

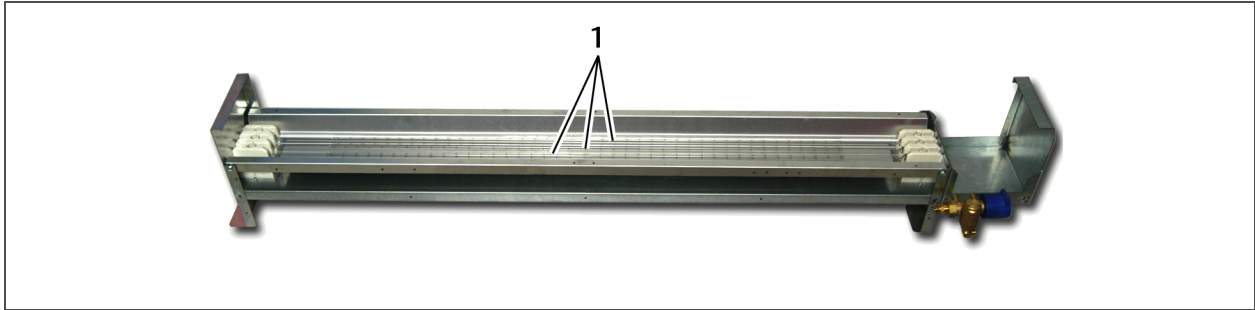

Item	Description
1	Infrared bulbs

9.4 Condensate-drain and Condensate-pump System Maintenance

9.4.1 Condensate Drain

Check for and clear obstructions in tubing during routine maintenance.

9.4.2 Condensate Pump



WARNING! Risk of electric shock. Can cause injury or death. Open all local and remote electric power-supply disconnect switches and verify that power is Off with a voltmeter before working within the condensate pump electrical connection enclosure. The Liebert® iCOM™ does not isolate power from the unit, even in the “Unit Off” mode. Some internal components require and receive power even during the “Unit Off” mode of the Liebert® iCOM.

To maintain the condensate pump:

1. Disconnect power to the unit using the disconnect switch.
2. Check for and clear obstructions in gravity lines leading to the condensate pump.
3. Remove the sump, clean with a stiff nylon brush and flush with water.
4. Inspect and clear clogs in the discharge check valve and float mechanism.
5. Reassemble and check for leaks.

9.5 Electric Reheat Maintenance

- Inspect and clean reheat elements.
- Inspect and tighten support hardware.

9.6 Electronic Expansion Valve (EEV) Maintenance

The EEV controls superheat through the Liebert® iCOM™ controls by actively measuring suction pressure via a transducer attached to the suction-line rotalock and suction temperature via a thermister strapped to the suction line. The EEV actively adjusts the orifice size and resulting mass flow of refrigerant to maintain the superheat setpoint (set in Liebert® iCOM). The EEV is used in place of the standard thermal expansion valve (TXV).



WARNING! Risk of electric shock. Can cause serious injury or death. The Liebert® iCOM microprocessor does not isolate power from the unit, even in the "Unit Off" mode. Some internal components require and receive power even during the "unit off" mode of the Liebert® iCOM control. Open all local and remote electric power disconnect switches and verify with a voltmeter that power is Off before working on any component of the system.

NOTE: Intermittent loss of subcooling may result in EEV/superheat instability. If superheat instability is observed, check for proper refrigerant level in receiver (see [Refrigerant Piping Guidelines for Air-cooled Systems](#) on page 35 for the proper charge level). If proper charge is observed in receiver, and superheat remains unstable, then increase superheat setting in the Liebert® iCOM to 15°F (8.49°C).

9.7 Compressor Maintenance



WARNING! Risk of over-pressurization of the refrigeration system. Can cause explosive discharge of high-pressure refrigerant, loss of refrigerant, environmental pollution, equipment damage, injury, or death. This unit contains fluids and gases under high pressure. Use extreme caution when charging the refrigerant system. Do not pressurize the system higher than the design pressure marked on the unit's nameplate. For systems requiring EU CE compliance (50 Hz), the system installer must provide and install a pressure relief valve in the high side refrigerant circuit that is rated same as the refrigerant high side “Max Allowable Pressure” rating that is marked on the unit serial tag. Do not install a shutoff valve between the compressor and the field installed relief valve. The pressure relief valve must be CE-certified to the EU Pressure Equipment Directive by an EU “Notified Body.”

9.7.1 Compressor Oil

NOTICE

Risk of improper compressor lubrication. Can cause compressor and refrigerant system damage.

Failure to use oil types, viscosities and quantities recommended by the compressor manufacturer may reduce compressor life and void the compressor warranty.

See oil types specified in **Table 9.3** below.

- Do not mix polyolester (POE) and mineral-based oils.
- Do not mix oils of different viscosities.
- Consult Vertiv technical support or the compressor manufacturer if questions arise.

Table 9.3 Compressor oil types for R-410A Refrigerant

Compressor Type	Oil Type
Copeland Scroll and Digital Scroll	POE Oil - ISO 32 Centistoke Viscosity ¹
1. Use Copeland POE Oil ULTRA 32-3MAF or other Copeland-approved oils.	
Source: DPN003950. Rev.5	

NOTE: See [Additional Oil Requirements for Scroll and Digital-scroll Compressors](#) on page 38, for additional oil based on the system's refrigerant charge.

9.7.2 Replacement Compressors

Replacement compressors are available through your Vertiv sales office. If the unit is under warranty, the replacement compressor must be obtained from and the original compressor returned to your local Vertiv sales office. Compressors are shipped in reusable packaging, and the original compressor should be returned in the same packaging.

9.7.3 Rotalock Valve on Digital-Scroll Compressors



WARNING! Risk of explosive discharge of high-pressure refrigerant. Can cause serious injury. Neutral and service ports on the rotalock valve do not have a valve core. Front-seat the service valves and relieve pressure from the compressor before loosening a part or a component attached to the service valve. Follow local codes to properly reclaim refrigerant.

- The Neutral port remains open to the compressor side in all positions of the valve stem, see **Figure 9.13** below. A high-pressure cut-out switch or low-pressure switch/transducer will be connected to this port.
- The Service port is closed to the system when valve stem is back-seated, see **Figure 9.13** below. It is open to the system as soon as the valve is adjusted away from the back-seated position.

Figure 9.13 Rotalock valve

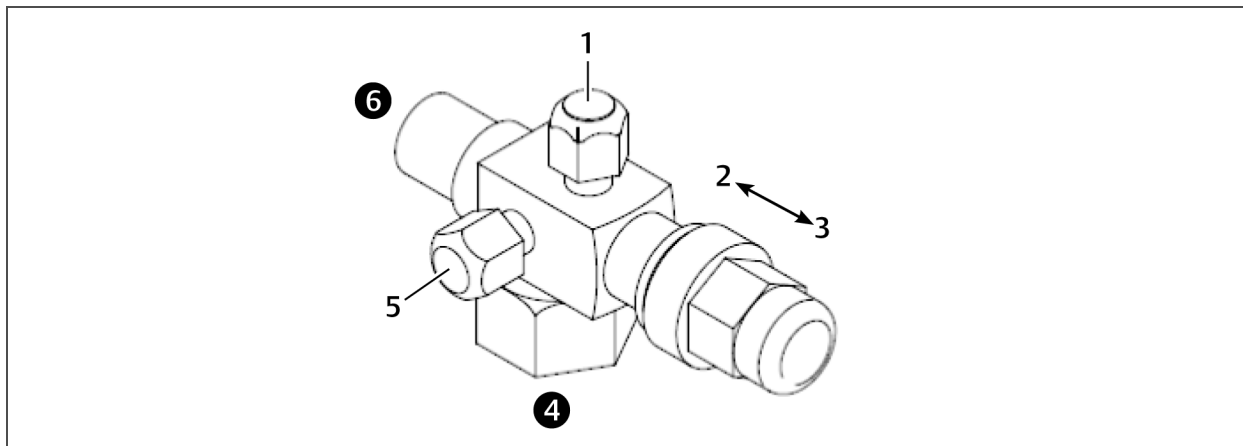

Item	Description
1	Service port (gauge)
2	Front seat
3	Back seat
4	Compressor side of valve
5	Neutral port
6	System side of valve

9.7.4 Unloading Solenoid(s) on a Digital-scroll Compressor

When replacing a digital-scroll compressor, the digital solenoid valve and coil must be replaced. The compressor and valve kit are shipped separately. The valve kit must be field-brazed to the top of the compressor in proper orientation and supported with the original factory bracket.

9.7.5 Compressor Electrical Failure (Motor Burnout)

If a burnout has occurred, a full system clean-out is required. If not cleaned, compressor and system problems will continue.

Consult the factory for compressor maintenance. Do not attempt to remove the compressor without first contacting Vertiv support at 1-800-543-2778.

9.7.6 Replacing a Compressor with Electrical Failure (Motor Burnout)



WARNING! Risk of electric shock. Can cause serious injury or death. The Liebert® iCOM microprocessor does not isolate power from the unit, even in the "Unit Off" mode. Some internal components require and receive power even during the "unit off" mode of the Liebert® iCOM control. Open all local and remote electric power disconnect switches and verify with a voltmeter that power is Off before working on any component of the system.



WARNING! Risk of over-pressurization of the refrigeration system. Can cause explosive discharge of high-pressure refrigerant, loss of refrigerant, environmental pollution, equipment damage, injury, or death. This unit contains fluids and gases under high pressure. Use extreme caution when charging the refrigerant system. Do not pressurize the system higher than the design pressure marked on the unit's nameplate. For systems requiring EU CE compliance (50 Hz), the system installer must provide and install a pressure relief valve in the high side refrigerant circuit that is rated same as the refrigerant high side "Max Allowable Pressure" rating that is marked on the unit serial tag. Do not install a shutoff valve between the compressor and the field installed relief valve. The pressure relief valve must be CE-certified to the EU Pressure Equipment Directive by an EU "Notified Body."

NOTE: Release of refrigerant to the atmosphere is harmful to the environment. Refrigerant must be recycled or discarded in accordance with federal, state, and local regulations.

1. Attach suction and discharge gauges to access fittings.
2. Front-seat service valves to isolate the compressor. Recover refrigerant using an approved recovery procedure and equipment. Use a filter drier when charging the system with recovered refrigerant.
3. Remove marked pressure transducer and discharge pressure switch. Disconnect all electrical connections.
4. Detach service valves from compressor.
5. Remove failed compressor.
6. Follow compressor manufacturer's suggested clean-out procedures.
7. Install replacement compressor and make all connections. Replace gaskets or seals on service valves. Replace unloading solenoid.
8. Evacuate, charge and operate per the appropriate procedure per local codes:
 - [Evacuation, Leak-testing, and Charging Air-cooled Systems with Receivers](#) on page 40

NOTICE

Risk of improper component re-installation. Can cause equipment damage.

Identify and mark location of suction pressure transducer and discharge pressure switch. These devices look similar and they must be reinstalled in their original location.

9.7.7 Compressor Mechanical Failure

If mechanical failure of the compressor has occurred, only the compressor needs replaced. A full system clean-out is not required..

9.7.8 Replacing a Compressor with Mechanical Failure



WARNING! Risk of electric shock. Can cause serious injury or death. The Liebert® iCOM microprocessor does not isolate power from the unit, even in the "Unit Off" mode. Some internal components require and receive power even during the "unit off" mode of the Liebert® iCOM control. Open all local and remote electric power disconnect switches and verify with a voltmeter that power is Off before working on any component of the system.



WARNING! Risk of over-pressurization of the refrigeration system. Can cause explosive discharge of high-pressure refrigerant, loss of refrigerant, environmental pollution, equipment damage, injury, or death. This unit contains fluids and gases under high pressure. Use extreme caution when charging the refrigerant system. Do not pressurize the system higher than the design pressure marked on the unit's nameplate. For systems requiring EU CE compliance (50 Hz), the system installer must provide and install a pressure relief valve in the high side refrigerant circuit that is rated same as the refrigerant high side "Max Allowable Pressure" rating that is marked on the unit serial tag. Do not install a shutoff valve between the compressor and the field installed relief valve. The pressure relief valve must be CE-certified to the EU Pressure Equipment Directive by an EU "Notified Body."

NOTE: Release of refrigerant to the atmosphere is harmful to the environment. Refrigerant must be recycled or discarded in accordance with federal, state, and local regulations.

1. Front-seat service valves to isolate the compressor. Recover refrigerant using an approved recovery procedure and equipment
2. Remove failed compressor.
3. Keep the replacement compressor sealed until installation is complete to the point that the system isolation valves are ready to be engaged. Keep exposure of the POE oil in compressor to atmosphere to a minimum.
4. Install replacement compressor, replace gaskets or seals on service valves, and make all connections. Replace unloading solenoid if equipped.
5. Once the compressor is completely installed, keep isolation valves closed to the system and open to compressor. Add dry nitrogen to compressor and check all connections for leaks. With no leaks confirmed, evacuate the isolated compressor prior to introducing to the rest of the system.
6. When evacuating the isolated compressor volume, pull a vacuum of 500 microns with no decay above 1000 microns within 20 minutes.
Once evacuation requirements of compressor are met, open the valves to open the compressor to the system.
7. Check compressor and system operation. Make any necessary adjustments for proper equipment operation.

9.8 Evaporator Coil Performance

The DA080, 085, 125, 150, and 165 units contain nested A-frame coils. This results in different evaporator (suction) temperatures between System 1 and System 2. The outer A-coil (System 1) will operate at a higher evaporator temperature than the inner A-coil (System 2) when operating at the same compressor loading.

The DA050 is a single-circuit A-frame coil.

9.9 Air-Cooled Condenser Maintenance

Restricted airflow will reduce operating efficiency and could result in high compressor-head pressure and loss of cooling.

- Clear coil surface of all debris that will inhibit airflow.
- Check for bent or damaged coil fins and correct.
- Do not permit snow to accumulate around or under outdoor unit.
- Periodically consider commercial cleaning of coil surface
- Inspect fans, motors and controls for proper operation.
- Check all piping and capillaries for proper support.
- Inspect for leaks.
- Check contactors for pitting. Replace if pitted.

10 PREVENTIVE MAINTENANCE CHECKLIST

Source: DPN002952, Rev. 4

Inspection Date	Job Name
Indoor Unit Model #	Indoor Unit Serial Number #
Condenser/Drycooler Model #	Condenser/Drycooler Serial #
Room Temperature/Humidity ° %	Ambient Temperature °

Not all units will have all components. To determine your unit's configuration, compare the [Indoor Unit Model #](#) above and the information in the Components and Nomenclature section.

Good maintenance practices are essential to minimizing operation cost and maximizing product life. Read and follow all applicable maintenance checks listed below. At a minimum, these checks should be performed semi-annually. However, maintenance intervals may need to be more frequent based on site-specific conditions. Review the unit user manual for further information on unit operation. We recommend the use of trained and authorized service personnel, extended service contracts, and factory-certified replacement parts. Contact your local sales representative for more details.

Check all that apply:

Evaporator/Filters

1. Check/Replace filters
2. Grille area unrestricted
3. Wipe section clean
4. Coil clean
5. Clean condensate pan
6. Clean trap in condensate drain
7. Check/Test filter-clog switch operation (if equipped)

Blower Section (EC fan)

1. Mounting bolts tight
2. Fan-guard bolts tight
3. Impeller spins freely
4. Check/Test air sail switch (if equipped)
5. Motor amp draw
- Compare to nameplate amps

#1	L1	L2	L3
#2	L1	L2	L3
#3	L1	L2	L3

6. Check belt tension and condition (replace if needed)
7. Check sheave/pulley (replace if worn)

Reheat

1. Inspect elements
2. Check wire connections (inside reheat box)
3. Reheat amp draw

L1

L2

L3

Infrared Humidifier (if equipped)

1. Check drain lines and trap for damage/clogs/leaks
2. Check/Clean pan for mineral deposits
3. Clean reflector
4. Check water make-up valve/supply lines/connections for leaks
5. Check humidifier lamps (replace if burnt out)
6. Check/Re-torque wire connections (inside humidifier box)
7. Check humidifier high-water alarm operation
8. Humidifier amp draw

L1

L2

L3

Condensate Pump (if equipped)

1. Check for debris in sump
2. Check operation of float(s) (free movement)
3. Check/Clean discharge check valve

Electrical Panel

1. Check fuses
2. Check contactors for pitting (Replace if pitted)
3. Check/Re-torque wire connections

Controls

1. Check/Verify control operation (Sequence)
2. Check/Test changeover device(s) (if equipped)
3. Check/Test water-detection device(s) (if equipped)
4. Check/Test CAN connection between indoor and outdoor units (if equipped)

Refrigeration Piping

1. Check refrigerant lines (clamps secure/no rubbing/no leaks)
2. Check for moisture (sight glass)
3. Check for restriction temperature drop across filter drier

Compressor Section

1. Check oil level
2. Check for oil leaks
3. Check compressor mounts (springs/bushings)
4. Cap tubes (not rubbing)
5. Check/Re-torque wire connections (inside compressor box)
6. Compressor operation (vibration/noise)
7. Check crank-case heater fuses/operation
8. Check for refrigerant leaks

9. Suction pressure	Circuit #1	_____	Circuit #2	_____
10. Discharge Pressure	Circuit #1	_____	Circuit #2	_____
11. Superheat	Circuit #1	_____	Circuit #2	_____
12. Low-pressure switch cut out	Circuit #1	_____	Circuit #2	_____
13. Low pressure cut in	Circuit #1	_____	Circuit #2	_____
14. High pressure cut out	Circuit #1	_____	Circuit #2	_____

15. Amp draw

Circuit #1A	L1	L2	L3
Circuit #1B (if tandem)	L1	L2	L3
Circuit #2A	L1	L2	L3
Circuit #2B (if tandem)	L1	L2	L3

Liebert® MC or MCV Condenser

1. Coil clean of debris (Clean coil if required)
2. Fans free of debris
3. Fans securely mounted
4. Motor bearings in good condition
5. Check all refrigerant lines for vibration isolation. Support as necessary
6. Check for refrigerant leaks
7. Check surge-protection device (if installed) status-indicator lights
8. Check/Re-torque wire connections
9. Check contactors for pitting (replace if pitted)
10. Verify operation sequence/set points
11. Charge verification:
 - a. Outdoor Ambient Temperature _____
 - b. Subcooling _____
 - c. Indoor-unit Return-air Temperature _____
 - d. Sight-glass level (if Lee-Temp or pumped refrigerant) _____
12. Motor amp draw

#1	L1	L2	L3
#2	L1	L2	L3
#3	L1	L2	L3
#4	L1	L2	L3
#5	L1	L2	L3
#6	L1	L2	L3
#7	L1	L2	L3
#8	L1	L2	L3
#9	L1	L2	L3
#10	L1	L2	L3
#11	L1	L2	L3
#12	L1	L2	L3
#13	L1	L2	L3
#14	L1	L2	L3
#15	L1	L2	L3
#16	L1	L2	L3

Liebert® EconoPhase Pumped-refrigerant Economizer (if equipped)

1. Check for refrigerant leaks
2. Check/Re-torque wire connections
3. Check contactors for pitting (replace if pitted)
4. Verify pump-speed control operation
5. Check pump mounting

This page intentionally left blank

APPENDICES

Appendix A: Technical Support and Contacts

A.1 Technical Support/Service in the United States

Vertiv™ Group Corporation

24x7 dispatch of technicians for all products.

1-800-543-2378

Liebert® Thermal Management Products

1-800-543-2778

Liebert® Channel Products

1-800-222-5877

Liebert® AC and DC Power Products

1-800-543-2378

A.2 Locations

United States

Vertiv Headquarters

1050 Dearborn Drive

Columbus, OH, 43085, USA

Europe

Via Leonardo Da Vinci 8 Zona Industriale Tognana

35028 Piove Di Sacco (PD) Italy

Asia

7/F, Dah Sing Financial Centre

3108 Gloucester Road

Wanchai, Hong Kong

This page intentionally left blank

Appendix B: Disassembling the DSE for Transport

The Liebert® DSE has a modular frame construction that allows separating the unit into three sections. Each of these sections is more easily maneuvered through tight spaces or placed in small elevators.

A qualified service technician with the required tools and recommended assistance can disassemble an air-cooled unit in about four hours, assuming refrigerant evacuation is not required.

This procedure requires four or more people for lifting the filter and electric-box assembly.



WARNING! Risk of over-pressurization of the refrigeration system. Can cause explosive discharge of high-pressure refrigerant, loss of refrigerant, environmental pollution, equipment damage, injury, or death. This unit contains fluids and gases under high pressure. Use extreme caution when charging the refrigerant system. Do not pressurize the system higher than the design pressure marked on the unit's nameplate. For systems requiring EU CE compliance (50 Hz), the system installer must provide and install a pressure relief valve in the high side refrigerant circuit that is rated same as the refrigerant high side "Max Allowable Pressure" rating that is marked on the unit serial tag. Do not install a shutoff valve between the compressor and the field installed relief valve. The pressure relief valve must be CE-certified to the EU Pressure Equipment Directive by an EU "Notified Body."



WARNING! Risk of top-heavy unit falling over. Improper handling can cause equipment damage, injury or death. Read all of the following instructions and verify that all lifting and moving equipment is rated for the weight of the unit before attempting to move, lift, remove packaging from or prepare the unit for installation.



CAUTION: Risk of contact with sharp edges and exposed fasteners. Can cause injury. Wear appropriate, OSHA-approved personal protective equipment (PPE) when installing the component.



CAUTION: Risk of handling heavy unit and component parts. Can cause injury and equipment damage. Use OSHA-recommended safe lifting techniques and/or lifting equipment rated for the weight of the unit.

NOTICE

Risk of improper disassembly. Can cause equipment damage.

Disassembling this unit requires substantial work, including reclaiming refrigerant and charging the unit, cutting and brazing refrigerant lines, cutting and brazing water lines, disconnecting and reconnecting electrical lines and moving heavy, bulky equipment. One member of the crew disassembling the unit must be qualified in wiring, brazing and refrigeration.

Improperly disassembling or reassembling the DSE may affect warranty.

The disassembly dimensions and details are described in the submittal documents included in the [Submittal Drawings](#) on page 127.

The following table lists the relevant documents by number and title.

Table B.1 Disassembly Dimension Drawings

Document Number	Title
Downflow Units	
DPN003532	Disassembly, DA050
DPN003140	Disassembly, DA080 and DA085
DPN003178	Disassembly, DA125, DA150 and DA165
Upflow Units	
DPN003166	Disassembly, DA080U and DA085U

B.1 Required Equipment

- Piano jacks
- Stepladder
- Refrigeration tools

B.2 Downflow DA050, DA080 and DA085 Disassembly

1. Remove the unit from its shipping skid before beginning.
2. Remove all panels except the top front accent.
3. Remove all filters. This allows access to the screws for metal plate blocking off the top coil and removal of the filter plate.
All wires are hot-stamped and all circuit board connectors are lettered to ease connection. Some cable ties must be cut and replaced. Refer to the unit's wiring schematic on the unit's dead-front panel for details.

NOTICE

Risk of improper handling and storage. Can cause equipment damage.

Do not lay the compressor section on its side. It must remain upright. The coil section also must remain upright.

4. Label the three quick-connect plugs from the compressor compartment and disconnect them.
5. Disconnect the two CAN connections and cut the wire ties going to the EEV boxes in the bottom of the compressor section.

6. Disconnect the compressor wire harness, including the crankcase heater wires, if present, from the contactor in the electric box.
7. Pull the conduit and wires into the compressor compartment.
8. Disconnect the fan motor wire harness from the bottom of the contactor in the electric box.
9. Pull the conduit and wires into the bottom section of the DSE.
10. Reheat—Optional Component
 - a. Disconnect the reheat wire harness from the bottom of the contactor in the electric box.
 - b. Unplug the low-voltage quick connect for the reheat safety wires.
 - c. Pull the conduit and wires into the unit's blower and coil assembly section.
11. Humidifier—Optional Component
 - a. Disconnect the humidifier wire harness from the bottom of the contactor in the electric box.
 - b. **For infrared humidifiers:** Remove the quick-connect plugs from the following low-voltage connections: 35-5 and 35-6 (safety under pan), 35-3 and 35-4 (humidifier make-up valve), and 8-5 and 8-7 (high water alarm).
 - c. Disconnect 35-3 and 35-4 from the control board.
 - d. Pull the conduit and wires into the unit's blower and coil assembly section.
12. Condensate Pump—Optional Component
 - a. Disconnect the condensate pump's high-voltage wiring harness.
 - b. Remove the low-volt wires from terminal strips #24 and #55.
 - c. Pull the conduit and wires into the unit's blower and coil assembly section.
13. Disconnect the air sail switch wires and pull them into the electric box.
14. Smoke Detector—Optional Component
 - a. Remove the smoke detector cover.
 - b. Remove the plug connector from the smoke detector and pull it into electric box.
 - c. Remove the wires from terminal strips #91, 92, 93 and route them into the smoke detector box.
 - d. Remove the sensing tube from top of the smoke detector.

The wand and tube will remain attached to filter and electric-box assembly.
15. Close the electric-box cover and the accent panel.
16. Remove the pull bar that supports the accent panel from the left end of unit, otherwise it will fall out when the compressor section is removed.
17. Evacuate and recover all refrigerant from the DSE.

Air-cooled units are shipped with a nitrogen holding charge.

NOTICE

Risk of compressor oil contamination with moisture. Can cause equipment damage.

We recommend front-seating the compressor service valves. Front-seating the valves keeps the nitrogen or refrigerant charge in the compressor and prevents moisture from contaminating the compressor oil.

18. Cut the insulation and pull it back from the piping.

19. Cut the refrigerant piping with a tubing cutter; if there is no Schrader fitting, let the nitrogen bleed out before cutting all the way through the pipe.

NOTE: We do not recommend un-sweating refrigerant connections.

20. Immediately cap and seal all piping that has been cut, including the suction and liquid lines.

Removing Compressor Assembly for Downflow DA050, DA080 and DA085

1. Secure the compressor wire harness to the compressor assembly.
2. Remove the 10 thread-cutting bolts holding the compressor section assembly to the filter and electric-box assembly and the blower and coil assembly.
There are five bolts in the front, four in the back and one on the top at the middle of the unit.
 - a. Begin removing bolts at the bottom of the unit and progress toward the top. Use this method for the front and back bolts.
 - b. Stabilize the compressor section before removing the top, middle bolt.

NOTICE

Risk of improper handling. Can cause compressor and/or piping damage.

The compressor section is top-heavy and has a small base. It must remain upright. Do not lay the compressor section on its side during or after removing it from the DSE. Do not remove shipping blocks from semi-hermetic compressors until the DSE is fully reassembled and ready for installation.

NOTE: We recommend using piano jacks when moving this section.

Removing Filter and Electric-box for Downflow DA050, DA080 and DA085

1. Using a stepladder to reach the top of the DSE, remove the filter support plate; it is attached to the filter and electric-box assembly with two screws, one on each end.
 - c. Remove tags from the Schrader fittings on top of the coil headers. Retain the tags for replacement during reassembly.
 - d. Remove 16 screws, (8) on each side, from the evaporator top cover plate to coil assembly. Coil top blocker will remain with top section for rigidity.
 - e. Remove coil access plates from the left side of the DSE.
 - f. Remove the four thread-cutting bolts securing the filter and electric-box assembly to the blower and coil assembly. There are two on the left and two on the right.
 - g. Separate the unit sections with caution.

Notice

Risk of improper handling. Can cause equipment damage.

- The filter and electric-box section should be moved forward and set on the floor.
 - Make sure to lift the coil plate over the Schrader fittings on the headers. We recommend using four people to remove this section. Special care is required when moving this section because the legs are not designed to withstand strong shocks.
 - The blower and coil assembly must remain upright. The coil is not secured to the blower and coil assembly.
 - Secure the coil to the bottom section with straps or a similar method before moving the section.
2. Move each section of the DSE to the installation location.

B.3 Reassembling Downflow DA050, DA080 and DA085

1. Replace the top section.
Make sure to clear the Schrader valves on the coil header.
2. Reconnect the filter and electric-box assembly to the blower and coil assembly using thread-cutting bolts. Torque the bolts to 225 in-lb. (25 Nm)
3. Reattach the evaporator top cover plate; there are eight screws on each side.
4. Reattach the filter support plate to the filter and electric-box assembly; there is one screw on each side.
5. Reattach the tags to the Schrader fittings on top of the coil headers.
6. Replace the compressor section.
Insert all compressor thread-cutting bolts before tightening any of the bolts.
7. Reinstall the pull bar to support the accent panel.
8. Reattach the low-voltage plugs in the compressor section.
9. Reconnect the wiring for the compressor, fan motor, reheat, humidifier, condensate pump, smoke detector and air sail switch.
10. Reattach the sensing tube to the top of the smoke detector.

Reconnecting Piping, Charging and Replacing Panels for Downflow DA050, DA080 and DA085

1. Piping must be reassembled in accordance with local codes.
2. Move insulation and plastic bushings away from the brazing area.
3. Wrap piping with wet cloths. Use copper fittings where required.

4. Refer to [Piping and Refrigerant Requirements](#) on page 29, for piping guidelines and to the ASHRAE Refrigeration Handbook for general, good-practice refrigeration piping.
5. Open the service valves on the compressor.
6. Reinsert the plastic bushings.
7. Charge the DSE with refrigerant; see the unit's nameplate for the proper charge.
8. Reinstall the galvanized panels on the left side of the coil.
9. Replace the filters.
10. Replace the panels.

Re-assembly Checklist for Downflow DA050, DA080 and DA085

1. Thread-cutting bolts reconnected and torqued to 225 in-lb. (25 Nm)
2. Top cover plate attached to coil
3. Filter plate attached
4. High-voltage wires connected to proper contactors:
 - a. Compressor
 - b. Fan motor
 - c. Reheat, if applicable
 - d. Humidifier, if applicable
 - e. Condensate pump, if applicable
5. Low-voltage wires connected
 - a. Actuator
 - b. Terminal strip
 - c. Plug connections
 - d. Smoke detector, if applicable
6. Coil access plates on right and left replaced
7. Humidifier lines brazed
8. Suction and liquid refrigerant lines brazed
9. Vacuum pulled and unit checked for leaks
10. Unit recharged
11. Filters replaced
12. Panels replaced

B.4 Downflow DA125, DA150 and DA165 Disassembly

1. Remove the unit from its shipping skid before beginning.
2. Remove all panels except the top front accent.
3. All wires are hot-stamped and all circuit board connectors are lettered to ease connection. Some cable ties must be cut and replaced. Refer to the unit's wiring schematic on the unit's dead-front panel for details.

NOTICE

Risk of improper handling. Can cause compressor and/or piping damage.

Do not lay the compressor section on its side. It must remain upright. The coil section also must remain upright.

4. Label the three quick-connect plugs from the compressor compartment and disconnect them.
5. Disconnect the CAN connections going to the EEV boxes in front of each compressor.
6. Disconnect the compressor wire harness, including the crankcase heater wires, from the contactor in the electric box.
7. Pull the conduit and wires into the compressor compartment.
8. Close the electric-box cover and the accent panel.
9. Evacuate and recover all refrigerant from the DSE.

Air-cooled units are shipped with a nitrogen holding charge.

NOTICE

Risk of compressor oil contamination with moisture. Can cause equipment damage.

We recommend front-seating the compressor service valves. Front-seating the valves keeps the nitrogen or refrigerant charge in the compressor and prevents moisture from contaminating the compressor oil.

10. Cut the insulation and pull it back from the piping.
11. Cut the refrigerant piping with a tubing cutter; if there is no Schrader fitting, let the nitrogen bleed out before cutting all the way through the pipe.

NOTE: We do not recommend un-sweating refrigerant connections.

12. Immediately cap and seal all piping that has been cut, including the suction and liquid lines.

Removing Compressor Assembly for Downflow DA125, DA150 and DA165

1. Secure the compressor wire harness to the compressor assembly.
2. Remove the 20 thread-cutting bolts holding the compressor section assembly to the filter and electric-box assembly and the blower and coil assembly.
There are eight bolts in the front, eight in the back and four in the bottom of the unit.
 - a. Begin removing bolts at the bottom of the unit and progress toward the top. Use this method for the front and back bolts.
 - b. Stabilize the compressor section before removing the bolts.

NOTICE

Risk of improper handling. Can cause compressor and/or piping damage.

The compressor section is top-heavy and has a small base. It must remain upright. Do not lay the compressor section on its side during or after removing it from the DSE.

NOTE: We recommend using piano jacks when moving this section.

Notice

Risk of improper handling. Can cause equipment damage.

- The blower and coil assembly must remain upright. The coil is not secured to the blower and coil assembly.
 - Secure the coil to the bottom section with straps or a similar method before moving the section.
3. Move each section of the DSE to the installation location.

B.5 Reassembling Downflow DA125, DA150 and DA165

1. Replace the compressor section.
Insert all thread-cutting compressor bolts before tightening any of the bolts.
2. Reattach the low-voltage plugs in the compressor section.
3. Reconnect the wiring for the compressor.

Reconnecting Piping, Charging and Replacing Panels for Downflow DA125, DA150 and DA165

1. Piping must be reassembled in accordance with local codes.
2. Move insulation and plastic bushings away from the brazing area.
3. Wrap piping with wet cloths. Use copper fittings where required.
4. Refer to [Piping and Refrigerant Requirements](#) on page 29, for piping guidelines and to the ASHRAE Refrigeration Handbook for general, good-practice refrigeration piping.
5. Open the service valves on the compressor.
6. Reinsert the plastic bushings.
7. Charge the DSE with refrigerant; see the unit's nameplate for the proper charge.
8. Reinstall the galvanized panels on the left side of the coil.
9. Replace the panels.
10. Install the filter plenum as instructed in the instructions included with the plenum.

Re-assembly Checklist for Downflow DA125, DA150 and DA165

1. Thread-cutting bolts reconnected and torqued to 225 in-lb. (25 Nm)
2. Top cover plate attached to coil
3. Filter plate attached
4. High-voltage wires connected to proper contactors on compressor
5. Low-voltage wires connected
 - a. Actuator
 - b. Terminal strip
 - c. Plug connections
6. Suction and liquid refrigerant lines brazed
7. Vacuum pulled and unit checked for leaks
8. Unit recharged
9. Panels replaced
10. Filter plenum installed.

B.6 Upflow DA080 and DA085 Disassembly

1. Remove the unit from its shipping skid before beginning.
2. Remove all panels except the top front accent.
3. Remove all filters. This allows easier access to items located in the filter and coil assembly.
4. All wires are hot-stamped and all circuit board connectors are lettered to ease connection. Some cable ties must be cut and replaced. Refer to the unit's wiring schematic on the unit's dead-front panel for details.
5. Label the three quick-connect plugs from the compressor compartment and disconnect them.

6. Disconnect the two CAN connections and cut the wire ties going to the EEV boxes in the bottom of the compressor section.
7. Disconnect the compressor wire harness, including the crankcase heater wires, if present, from the contactor in the electric box.
8. Pull the conduit and wires into the compressor compartment.
9. Reheat-Optional Component
 - a. Disconnect the reheat wire harness from the bottom of the contactor in the electric box.
 - b. Unplug the low-voltage quick connect for the reheat safety wires.
 - c. Pull the conduit and wires into the unit's filter and coil assembly section.
10. Humidifier-Optional Component
 - a. Disconnect the humidifier wire harness from the bottom of the contactor in the electric box.
 - b. **For infrared humidifiers:** Remove the quick-connect plugs from the following low-voltage connections: 35-5 and 35-6 (safety under pan), 35-3 and 35-4 (humidifier makeup valve), and 8-5 and 8-7 (high water alarm).
 - c. Disconnect 35-3 and 35-4 from the control board.
 - d. Pull the conduit and wires into the unit's filter and coil assembly section.
11. Condensate Pump-Optional Component
 - a. Disconnect the condensate pump's high-voltage wiring harness.
 - b. Remove the low-volt wires from terminal strips #24 and #55.
 - c. Pull the conduit and wires into the unit's filter and coil assembly section.
12. Smoke Detector-Optional Component
 - a. Remove the smoke detector cover.
 - b. Remove the plug connector from the smoke detector and pull it into the electric box.
 - c. Remove the wires from terminal strips #91, 92, 93 and route them into the smoke detector box.
 - d. Remove the sensing tube from the bottom of the plastic elbow.
13. Close the electric-box cover and the accent panel.
14. Remove the pull bar that supports the accent panel from the left end of the unit, otherwise it will fall out when the compressor section is removed.
15. Evacuate and recover all refrigerant from the DSE. Air-cooled units are shipped with a nitrogen holding charge.

NOTICE

Risk of compressor oil contamination with moisture. Can cause equipment damage.

We recommend front-seating the compressor service valves. Front-seating the valves keeps the nitrogen or refrigerant charge in the compressor and prevents moisture from contaminating the compressor oil.

16. Cut the insulation and pull it back from the piping.
17. Cut the refrigerant piping with a tubing cutter; if there is no Schrader fitting, let the nitrogen bleed out before cutting all the way through the pipe.

NOTE: We do not recommend un-sweating refrigerant connections.

18. Immediately cap and seal all piping that has been cut, including the suction and liquid lines.

Removing Compressor Assembly for Upflow DA080 and DA085

1. Secure the compressor wire harness to the compressor assembly.
2. Remove the 10 thread-cutting bolts holding the compressor section assembly to the filter, the electric-box assembly and the blower and coil assembly. There are five bolts in the front, four in the back and one on the top at the middle of the unit.
 - a. Begin removing bolts at the bottom of the unit and progress toward the top. Use this method for the front and back bolts.
 - b. Stabilize the compressor section before removing the top, middle bolt.

NOTICE

Risk of improper handling. Can cause compressor and/or piping damage.

The compressor section is top-heavy and has a small base. It must remain upright. Do not lay the compressor section on its side during or after removing it from the DSE.

NOTE: We recommend using piano jacks when moving this section.

Removing Blower and Electric-box for Upflow DA080 and DA085

1. Remove the access plate from right end of unit. This will provide a place to grasp the blower and electric-box assembly and move it. Remove the coil access plates on the left side of the unit for clearance when brazing the suction and discharge lines.
2. Remove the thread-cutting bolts holding the unit sections together; there are four on the left and four on the right.
3. Separate the unit sections with caution.

NOTICE

Risk of improper handling. Can cause damage to the DSE.

- The blower and electric-box section should be moved forward and set on the floor. We recommend using four people to remove this section.
 - The filter and coil assembly must remain upright. The coil is not secured to the filter and coil assembly.
 - Secure the coil to the bottom section with straps or a similar method before moving the section.
4. Move each section of the DSE to the installation location.

B.7 Reassembling Upflow DA080 and DA085

1. Replace the top section. Make sure to clear the Schrader valves on the coil header.
2. Reattach the top section using thread-cutting bolts; there are four on each side. Torque the bolts to 225 in-lb. (25 Nm)
3. Reinstall the motor access plate. Do not replace the left end coil access plates until brazing is finished.
4. Reattach compressor section. Insert all compressor thread-cutting bolts before tightening them all down.
5. Reinstall the pull bar to support the accent panel, if applicable.
6. Reattach the low-voltage plugs in the compressor section.
7. Reconnect the wiring for the compressor, reheat, humidifier, condensate pump and smoke detector if applicable.
8. Reattach the sensing tube.
9. Piping must be reassembled in accordance with local codes.

10. Move insulation and plastic bushings away from the brazing area.
11. Wrap piping with wet cloths. Use copper fittings where required.
12. Refer to [Piping and Refrigerant Requirements](#) on page 29, for piping guidelines and to the ASHRAE Refrigeration Handbook for general, good-practice refrigeration piping.
13. Open the service valves on the compressor.
14. Reinsert the plastic bushings.
15. Pull vacuum, check for leaks, and charge the DSE with refrigerant. See the unit's nameplate for the proper charge.
16. Reinstall the galvanized panels on the left side of the coil.
17. Replace the filters.
18. Replace the panels.

Reassembly Checklist for Upflow DA080 and DA085

1. Thread-cutting bolts reconnected and torqued to 225 in-lb. (25 Nm)
2. High-voltage wires connected to proper contactors:
 - a. Compressor
 - b. Reheat, if applicable
 - c. Humidifier, if applicable
 - d. Condensate pump, if applicable
3. Low-voltage wires connected
 - a. Terminal strip
 - b. Plug connections
 - c. Smoke detector, if applicable
4. Coil access plates on left replaced
5. Motor access plate on right side replaced
6. Suction and liquid refrigerant lines brazed
7. Vacuum pulled and unit checked for leaks
8. Unit recharged
9. Filters replaced
10. Panels replaced

This page intentionally left blank

Appendix C: Submittal Drawings

The submittal drawings are in the order of document part number (DPN). **Table C.1** below, groups the drawings by topic/application.

Table C.1 Submittal-drawings Contents

Document Number	Title
Component Location	
DPN003452	Component Location, Typical, Downflow Models
DPN003451	Component Location, Typical, Upflow Models
Planning Dimensions - Downflow Units	
DPN003533	Cabinet Dimensional Data, DA050
DPN004083	Cabinet Dimensional Data, DA080 and DA085
DPN003175	Cabinet Dimensional Data, DA125, DA150 and DA165
Planning Dimensions - Upflow Units	
DPN002950	Cabinet Dimensional Data, DA080U and DA085U
Planning Dimensions - Floor Stands	
DPN004079	Floorstand Dimensional Data, Downflow, DA050
DPN004073	Floorstand Dimensional Data, Downflow and Upflow, DA080 and DA085
DPN003177	Floorstand Dimensional Data, Downflow, DA125, DA150 and DA165
Planning Dimensions - Plenums	
DPN003514	Plenum Dimensional Data, Downflow, DA050, DA080 and DA085
DPN004081	Plenum Dimensional Data, Upflow, DA080U and DA085U
Piping Schematics	
DPN002615	Piping Schematic, DA050, DA080 and DA085 with MC Condenser
DPN002340	Piping Schematic, DA125, DA150 and DA165 with MC Condenser
DPN004476	Piping Schematic, DA125, DA150 and DA165 with MCV Condenser
Piping Arrangement - Liebert® MC Condenser and EconoPhase Pump Locations	
DPN003994	Considerations for mounting MC Condenser/EconoPhase Above or at Same Level as DSE
DPN003552	Typical arrangement for single-circuit system
DPN002324	Typical arrangement for dual-circuit system
Piping Connections - Downflow Units	
DPN003531	Connection Locations, DA050
DPN004080	Connection Locations, DA080 and DA085
DPN002312	Connection Locations, DA125
DPN004037	Connection Locations, DA150 and DA165

Table C.1 Submittal-drawings Contents (continued)

Document Number	Title
Piping Connections - Upflow Units	
DPN002951	Connection Locations, DA080U and DA085U
Electrical Connections	
DPN004387	Electrical Field Connections, Upflow & Downflow, DA050, DA080, and DA085 Models
DPN004388	Electrical Field Connections, Downflow Models, DA125, DA150, and DA165
DPN003284	CANbus cable connections between indoor unit, 1 Liebert® MC condenser and optional Liebert® EconoPhase pump
DPN002361	CANbus cable connections between indoor unit, 2 Liebert® MC condensers and optional Liebert® EconoPhase pump
DPN003886	CANbus cable connections between indoor unit, Liebert® MCV condenser
Unit-to-Unit Networking	
DPN004351	Liebert® iCOM Unit-to-unit Network Connections
Disassembly Dimensions - Downflow Units	
DPN003532	Disassembly, DA050
DPN003140	Disassembly, DA080 and DA085
DPN003178	Disassembly, DA125, DA150 and DA165
Disassembly Dimensions - Upflow Units	
DPN003166	Disassembly, DA080U and DA085U

COMPONENT LOCATION DIAGRAM DA050 - DA165

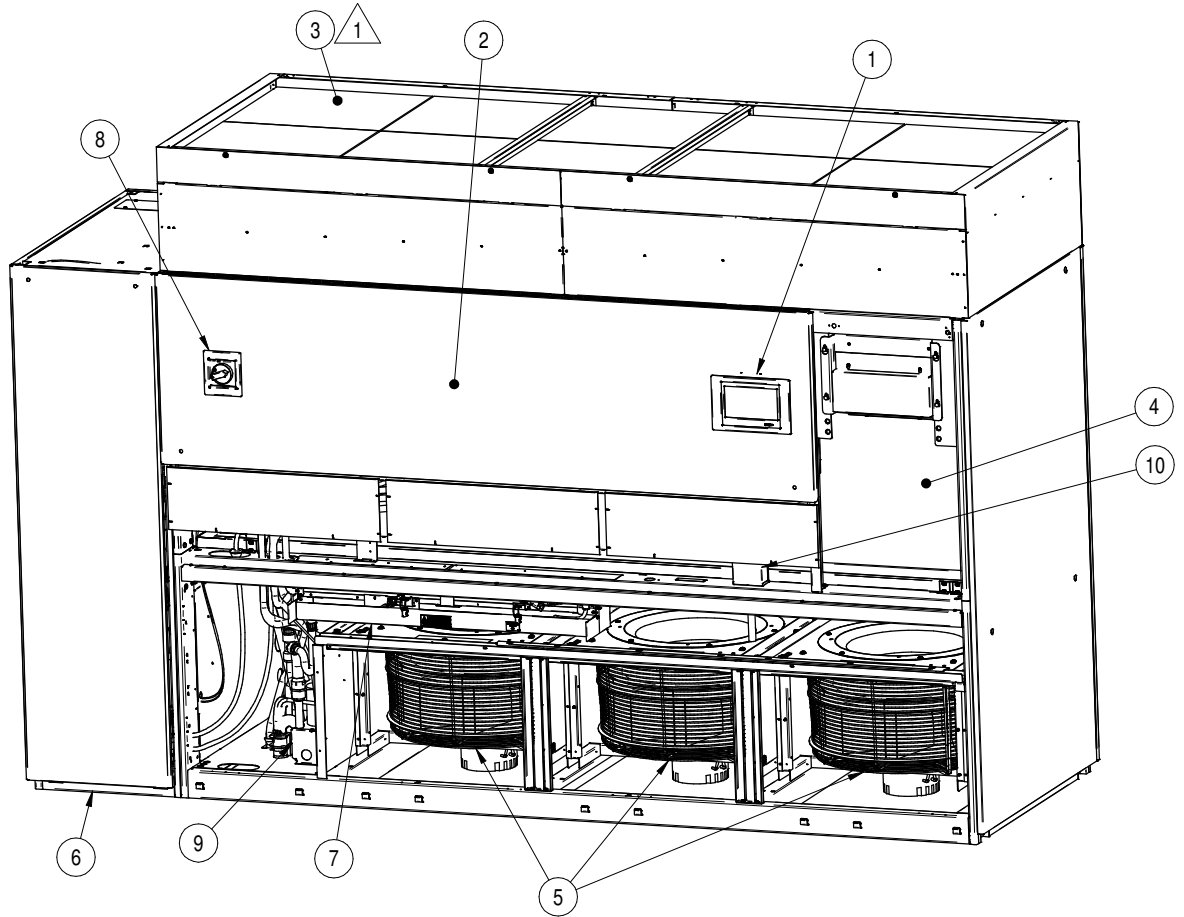

- | | |
|--|-----------------------------------|
| 1. iCOM Control Display | 7. Infrared Humidifier (optional) |
| 2. Electric Box | 8. Disconnect (optional) |
| 3. Filter Plenum (not shipped with unit) | 9. Condensate Pump (optional) |
| 4. Evaporator Coil | 10. Smoke Sensor (optional) |
| 5. Fan Modules | |
| 6. Compressor Section | |

Notes:

1. Filter Plenum not available on DA050/080/085 units.
 2. DA050/080/085 filters are located above the Electric Panel and can be accessed from the front of the unit.

COMPONENT LOCATION DIAGRAM DA080U & DA085U

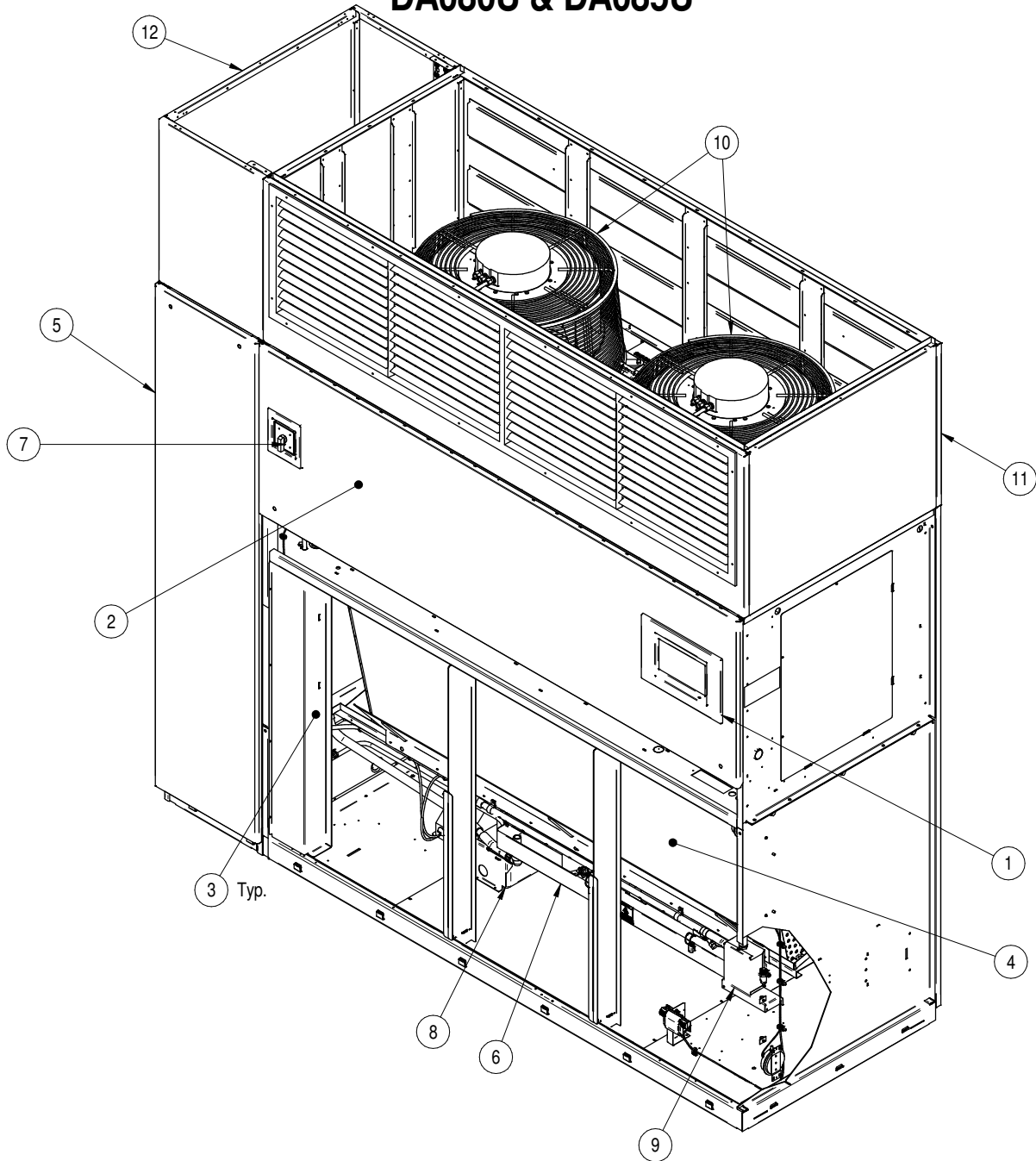

- | | |
|------------------------------------|--|
| 1. iCOM Control Display | 7. Disconnect |
| 2. Electric Box | 8. Condensate Pump (optional) |
| 3. Filters (not shown for clarity) | 9. Smoke Sensor (optional) |
| 4. Evaporator Coil | 10. EC Fans |
| 5. Compressor Section | 11. Plenum (Front Discharge shown) |
| 6. Infrared Humidifier (optional) | 12. Compressor Section Plenum (optional, ordered separately) |

CABINET DIMENSIONAL DATA DOWNFLOW DA050 AIR COOLED

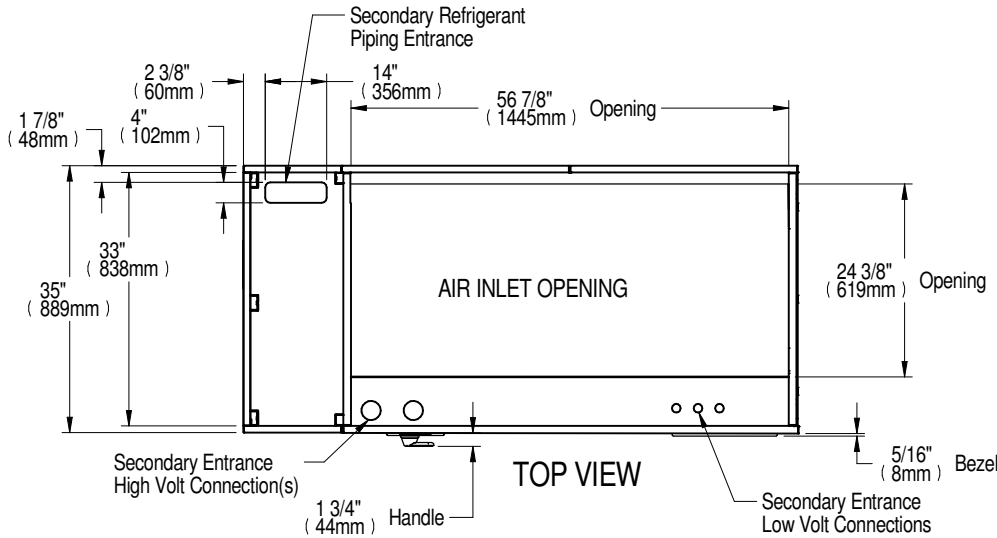

Note:

1. Filters are accessible through top of unit only.
2. Downflow electrical connections can be made from top or bottom of unit.

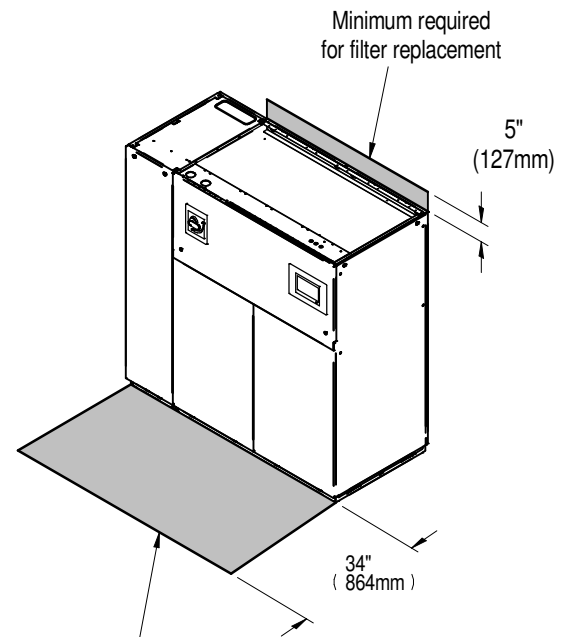
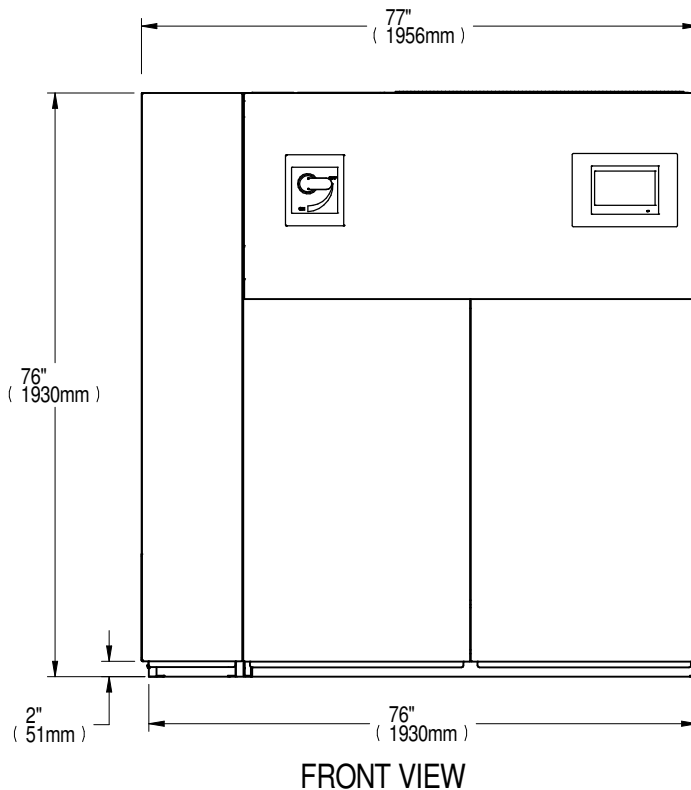

Shaded area indicates a recommended minimum clearance be provided for component access.

APPROXIMATE DRY WEIGHT lb (kg)
1590 (721)

PRIMARY CONNECTION LOCATIONS DOWNFLOW DA080-DA085 SCROLL OR DIGITAL SCROLL COMPRESSOR MODELS

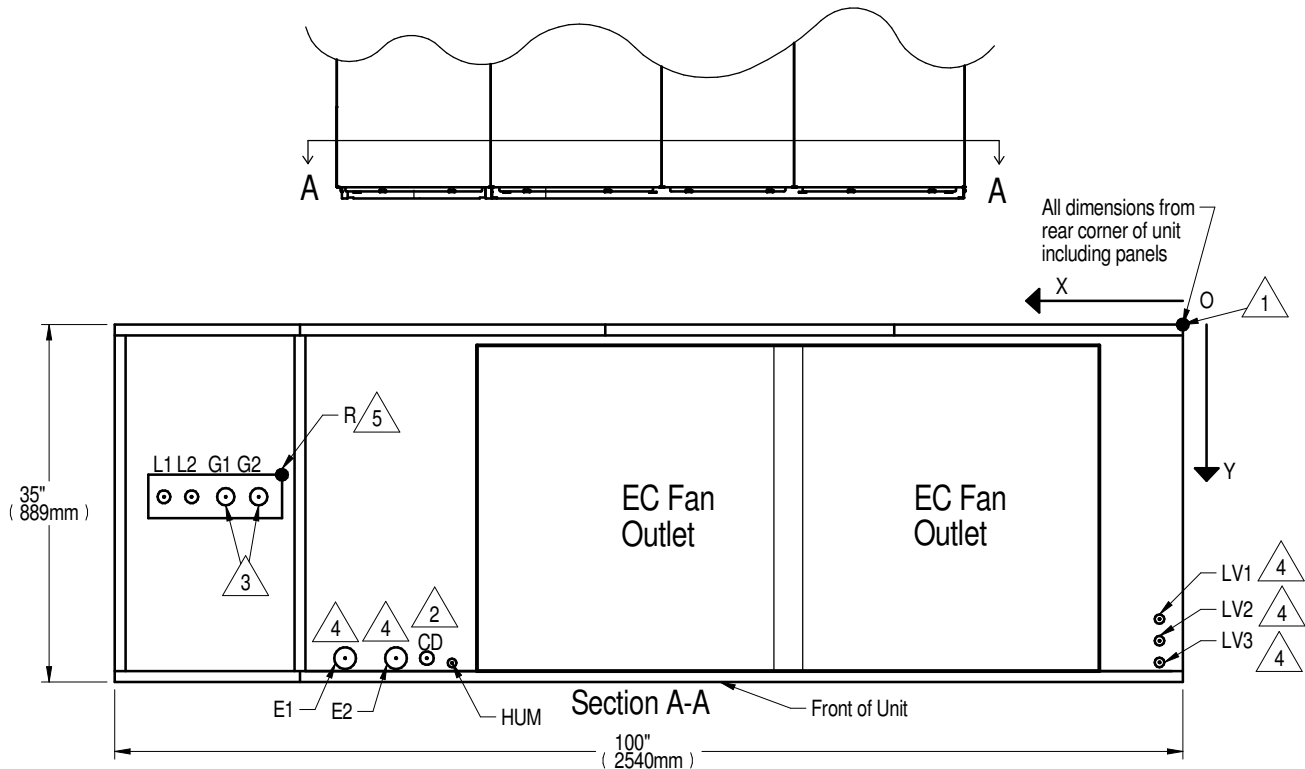

POINT	DESCRIPTION	X in. (mm)	Y in. (mm)	CONNECTION SIZE / OPENING
R	REFRIGERANT ACCESS ⁵	82-7/8 (2105)	13-11/16 (348)	15" (379mm) X 5" (127mm)
L1	LIQUID LINE SYSTEM 1	94-11/16 (2405)	16-3/4 (425)	5/8" O.D. Cu
L2	LIQUID LINE SYSTEM 2	91-7/8 (2334)		
G1	HOT GAS DISCHARGE 1 ³	88-3/4 (2254)	16-3/8 (416)	1-1/8" O.D. Cu
G2	HOT GAS DISCHARGE 2 ³	85-9/16 (2173)		
CD	CONDENSATE DRAIN ² (infrared humidifier or no humidifier)	68-3/8 (1737)	31-3/8 (797)	3/4" NPT FEMALE
	W/ OPTIONAL PUMP			1/2" O.D. Cu
HUM	HUMIDIFIER SUPPLY LINE	76-1/2 (1943)	29 (737)	1/4" O.D. Cu
E1	ELECTRICAL CONN. (HIGH VOLT)	78-1/2 (1994)	31-1/8 (791)	2-1/2"
E2		75-3/8 (1915)		
LV1	ELECTRICAL CONN. (LOW VOLT) ⁴	2 (51)	29 (737)	7/8"
LV2			30-7/8 (784)	
LV3			32 (813)	

Notes:

- ¹ Drawing not to scale. All dimensions from rear corner of unit including panels, and have a tolerance of $\pm 1/2"$ (13mm).
- ² Field pitch Condensate Drain line a minimum of 1/8" (3.2 mm) per foot (305 mm). All units contain a factory installed condensate trap. Do not trap external to the unit. Select appropriate drain system materials. The drain line must comply with all local codes.
- ³ When piping out the top of the unit, install traps in the discharge lines in the bottom of the unit before running lines to the top.
- ⁴ Opening for conduit chase, E1 and E2 are openings for conduit for connections to 2-1/2", 1-3/4", and 1-3/8" knockouts at electric panel.
- ⁵ See DPN004083 for alternate piping from the top of the unit. Alternate access is available on all units except 575V.

CABINET DIMENSIONAL DATA DOWNFLOW AIR COOLED DA125, DA150 & DA165 MODELS

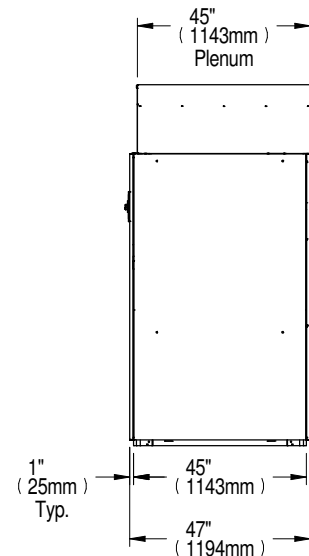
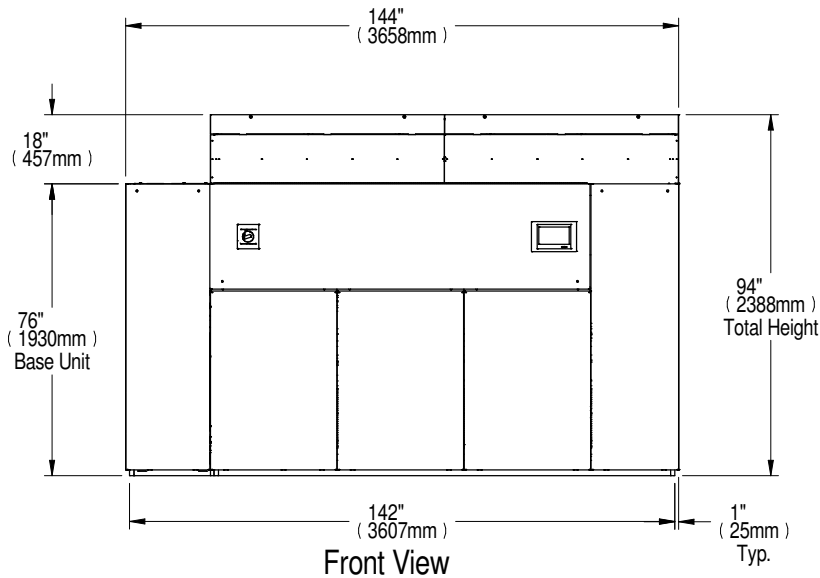
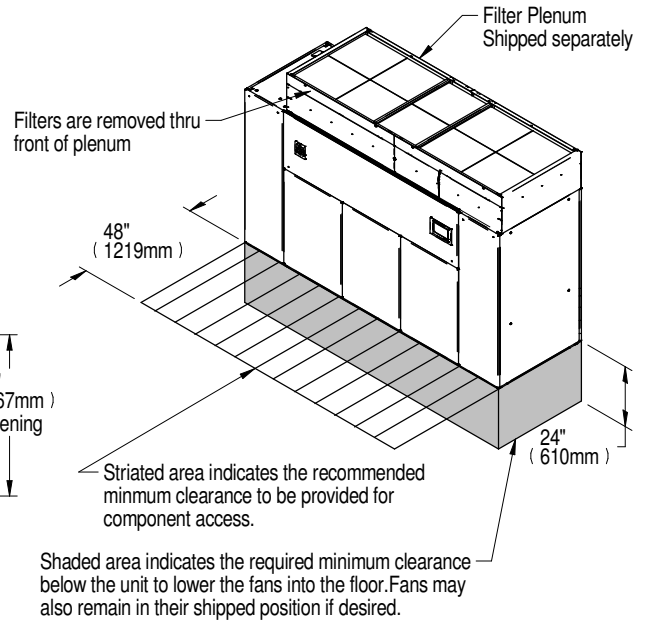
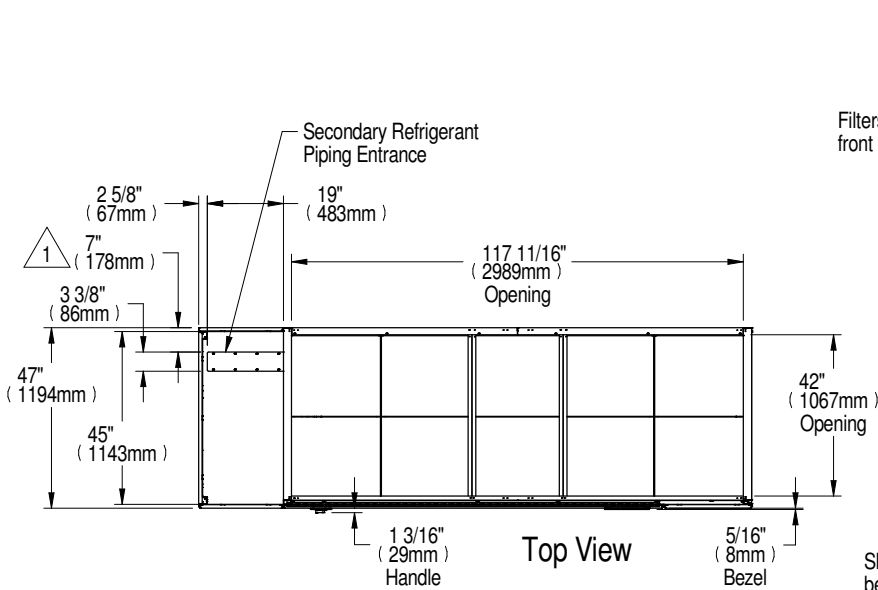

Model No.	Approximate Dry Weight lb(kg)
DA125	3465 (1572)
DA150/DA165	3574 (1621)

Notes:

1. 7" for DA125, 4" for DA150 & DA165.

CABINET DIMENSIONAL DATA UPFLOW DA080-DA085

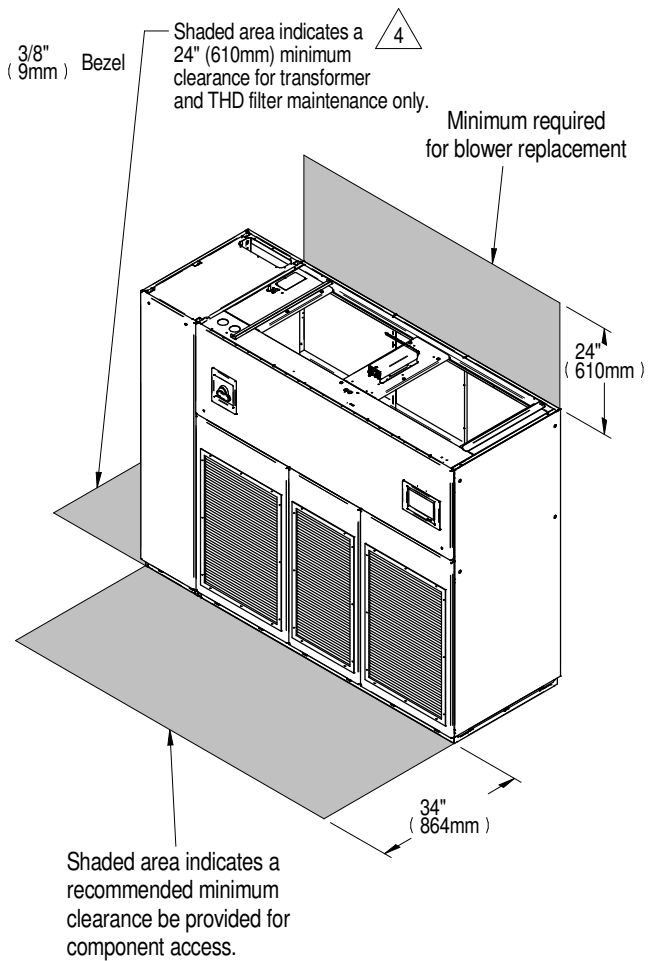
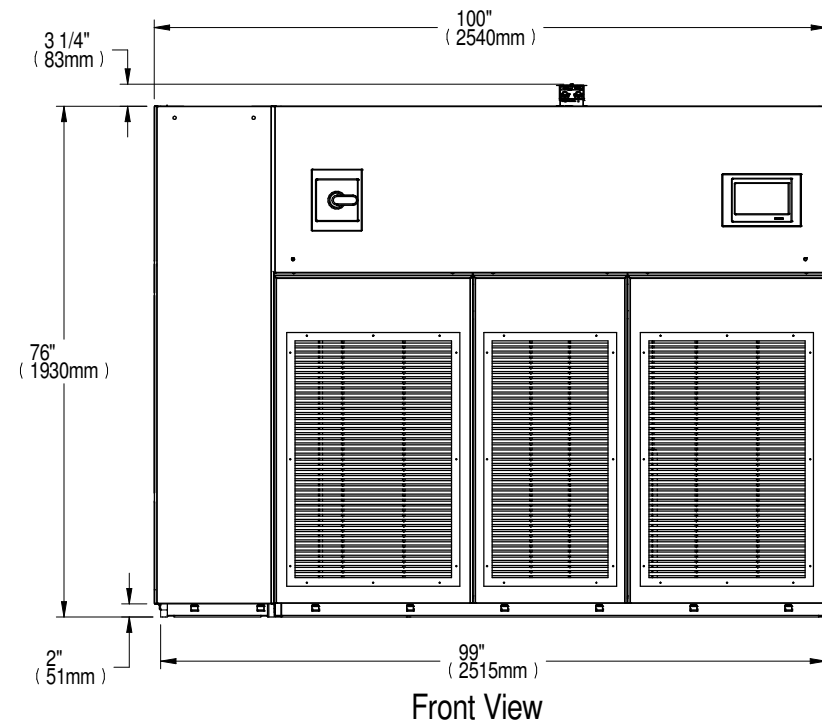
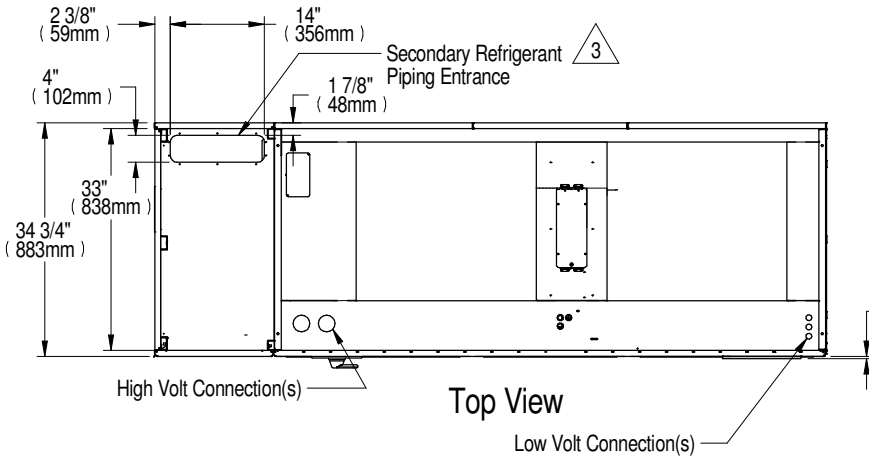

Approximate Dry Weight lbs. (kg)
2150 (977) ²

Notes:

1. Front air return unit shown.

² Fan weight not included in this unit weight. Fan is installed in Plenum. Add 120lbs. (54kg) for 575V Transformer.

³ Secondary Refrigerant Piping Entrance not available with 575V.

⁴ Unit power must be off when performing transformer and THD filter maintenance.

CABINET DIMENSIONAL DATA UPFLOW DA080-DA085

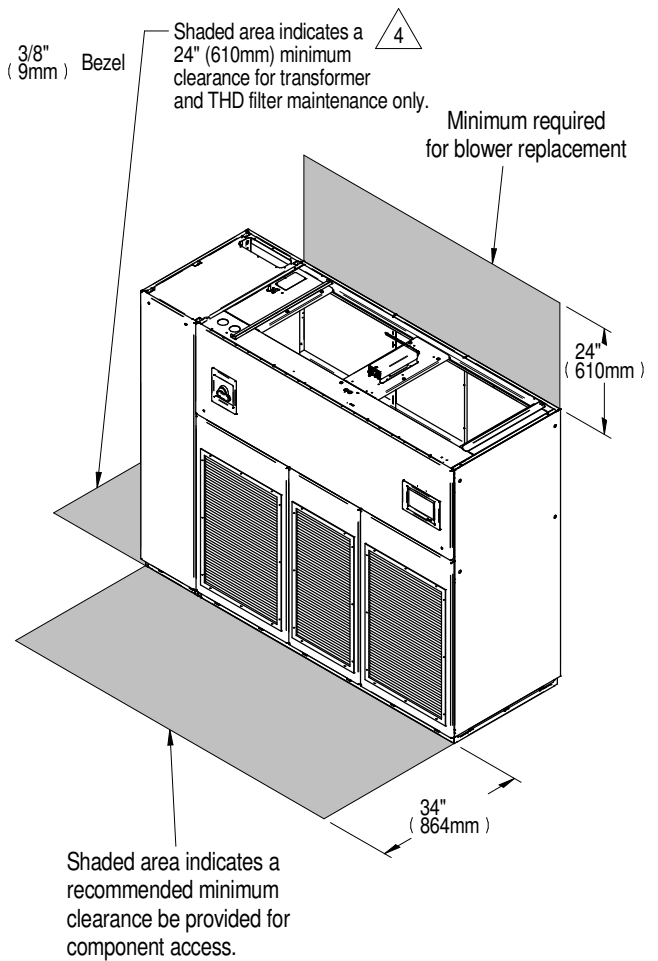
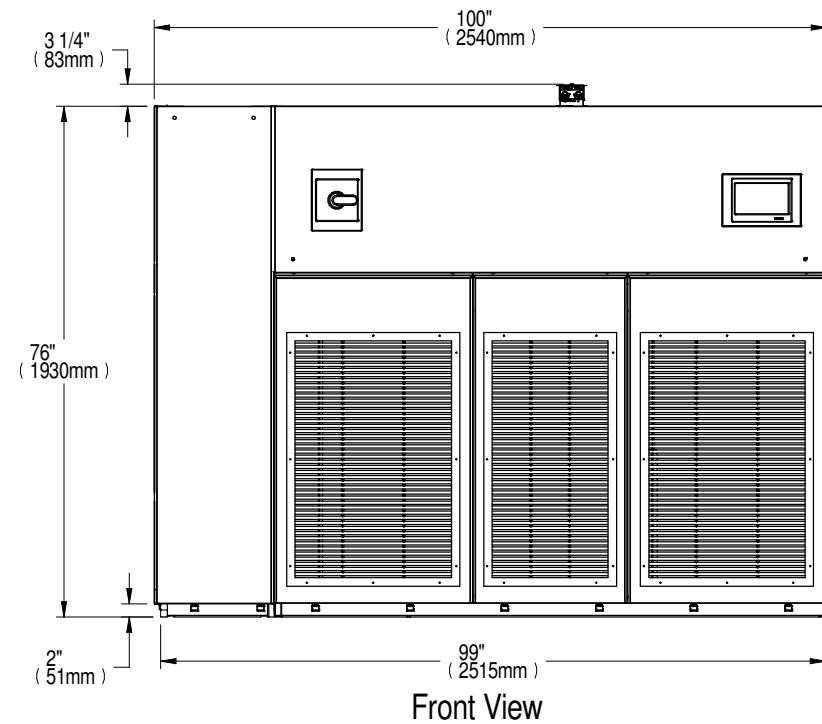
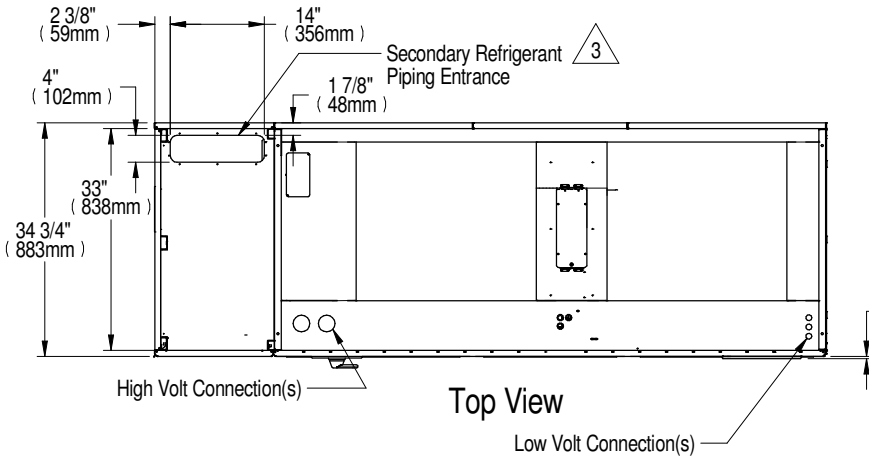

Approximate Dry Weight lbs. (kg)
2150 (977) ²

Notes:

1. Front air return unit shown.
- ² Fan weight not included in this unit weight. Fan is installed in Plenum. Add 120lbs. (54kg) for 575V Transformer.
- ³ Secondary Refrigerant Piping Entrance not available with 575V.
- ⁴ Unit power must be off when performing transformer and THD filter maintenance.

CABINET DIMENSIONAL DATA UPFLOW DA080-DA085

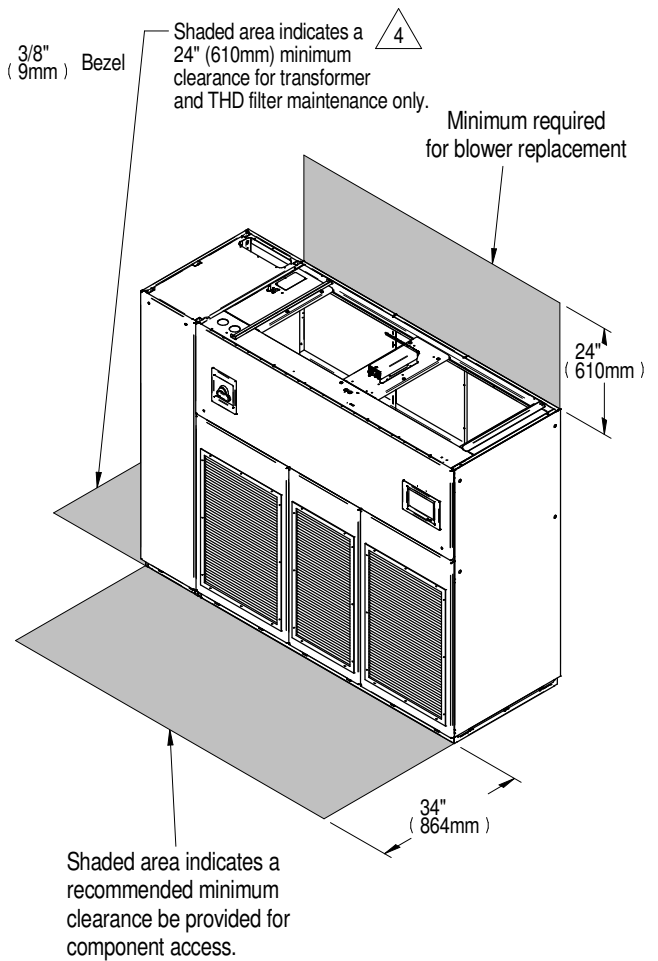
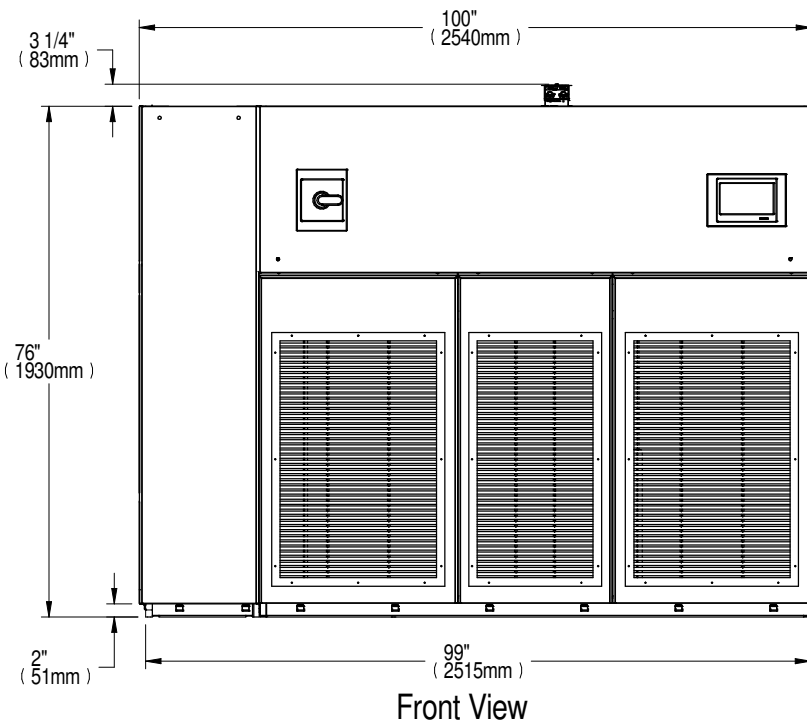
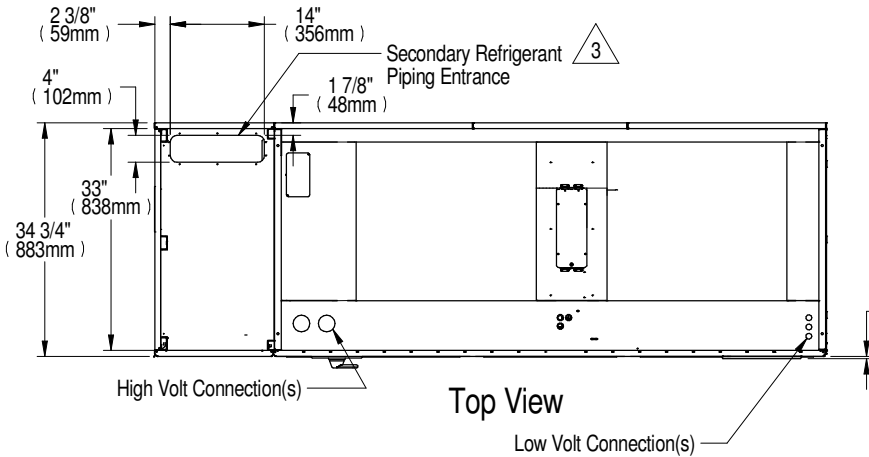

Approximate Dry Weight lbs. (kg)
2150 (977) (2)

Notes:

1. Front air return unit shown.

(2) Fan weight not included in this unit weight. Fan is installed in Plenum. Add 120lbs. (54kg) for 575V Transformer.

(3) Secondary Refrigerant Piping Entrance not available with 575V.

(4) Unit power must be off when performing transformer and THD filter maintenance.

CABINET DIMENSIONAL DATA UPFLOW DA080-DA085

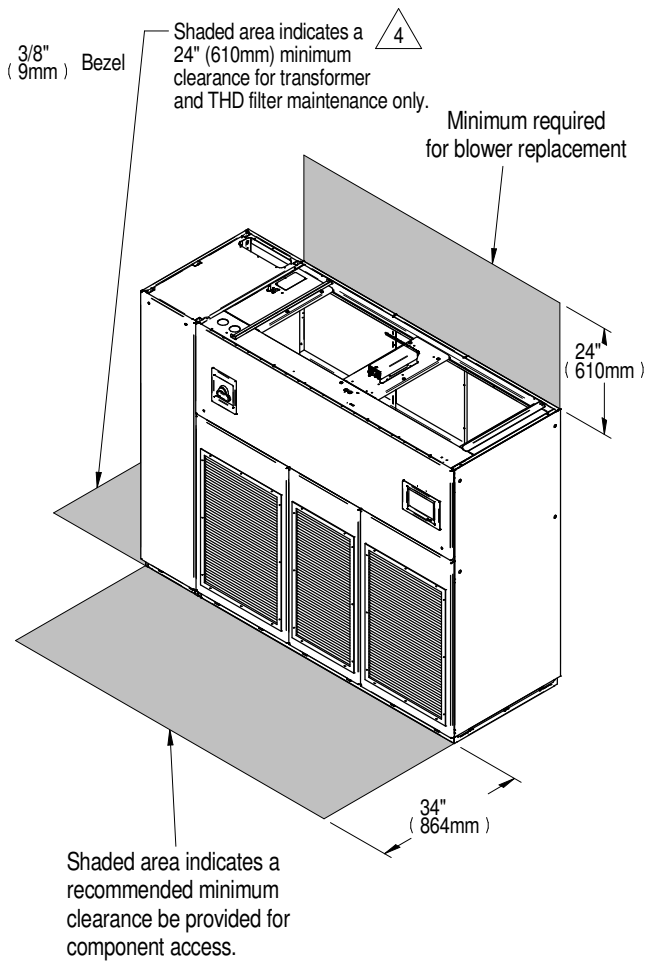
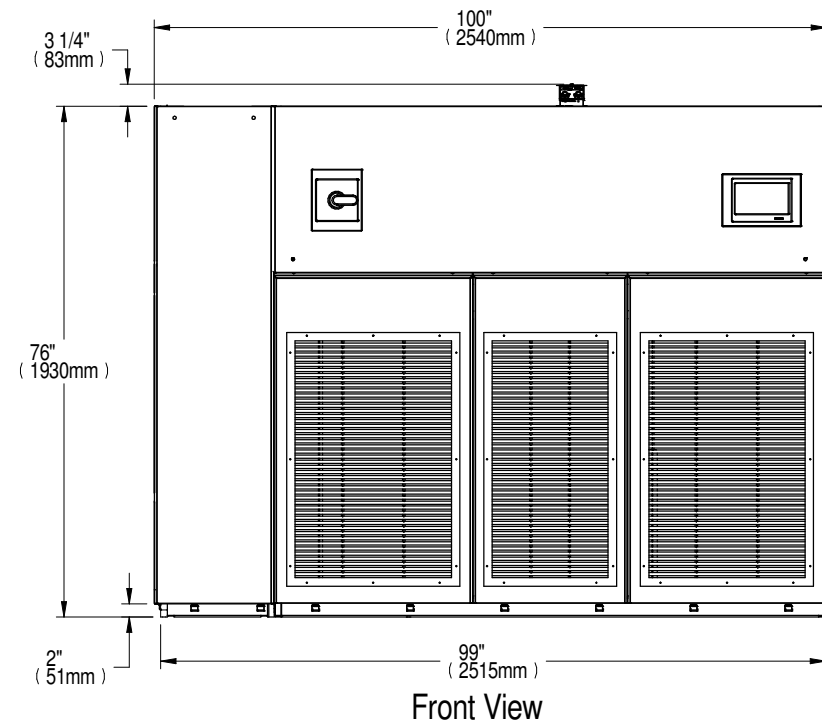
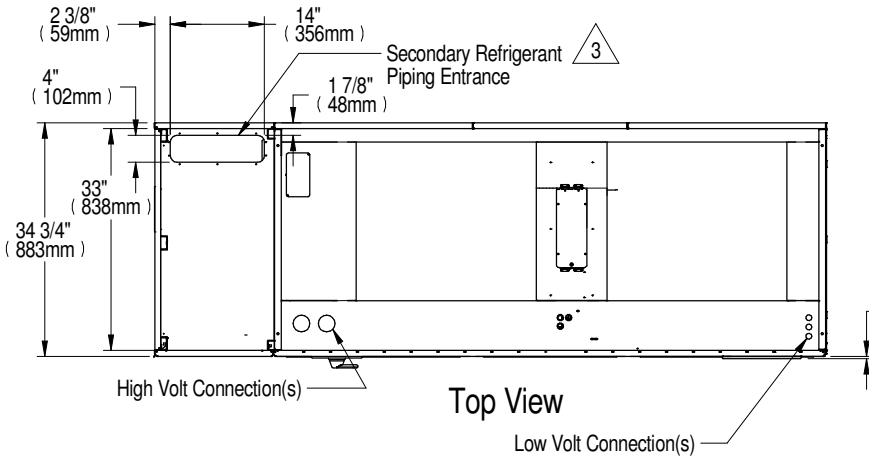

Approximate Dry Weight lbs. (kg)
2150 (977) (2)

Notes:

1. Front air return unit shown.

(2) Fan weight not included in this unit weight. Fan is installed in Plenum. Add 120lbs. (54kg) for 575V Transformer.

(3) Secondary Refrigerant Piping Entrance not available with 575V.

(4) Unit power must be off when performing transformer and THD filter maintenance.

CABINET DIMENSIONAL DATA UPFLOW DA080-DA085

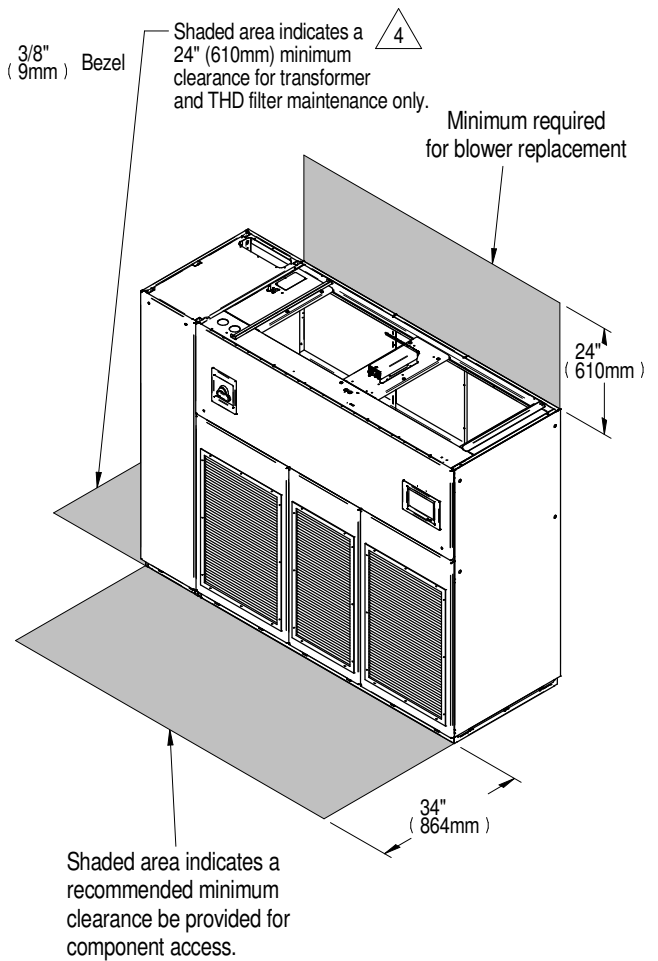
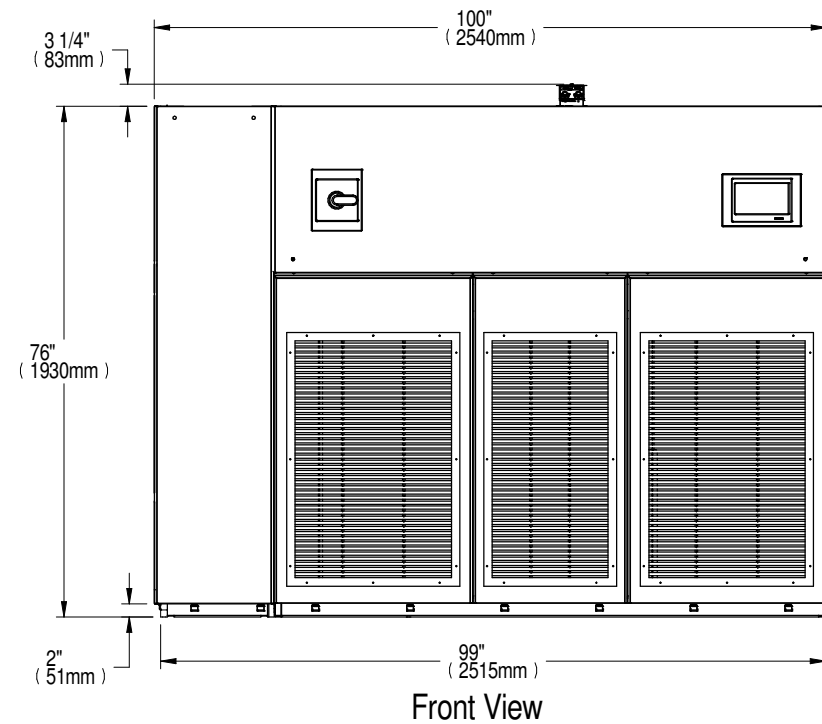
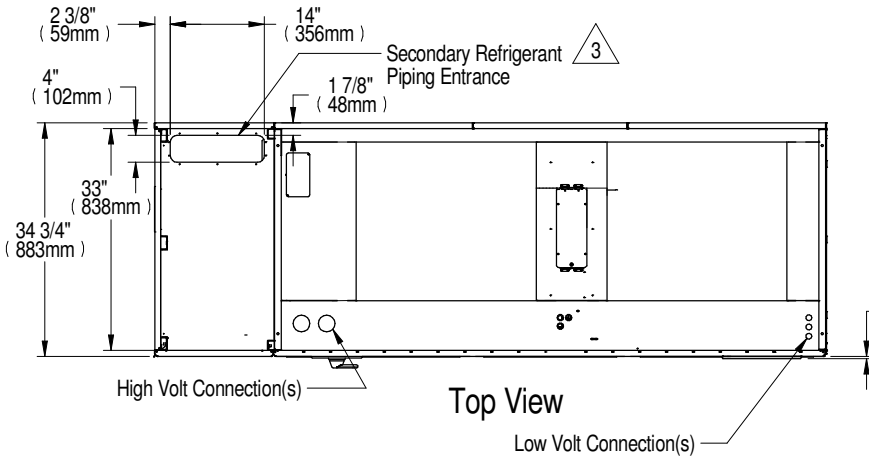

Approximate Dry Weight lbs. (kg)
2150 (977) ²

Notes:

1. Front air return unit shown.
- ² Fan weight not included in this unit weight. Fan is installed in Plenum. Add 120lbs. (54kg) for 575V Transformer.
- ³ Secondary Refrigerant Piping Entrance not available with 575V.
- ⁴ Unit power must be off when performing transformer and THD filter maintenance.

PRIMARY CONNECTION LOCATIONS DOWNFLOW AIR COOLED DA150 & DA165 MODELS WITH AND WITHOUT ECONOPHASE

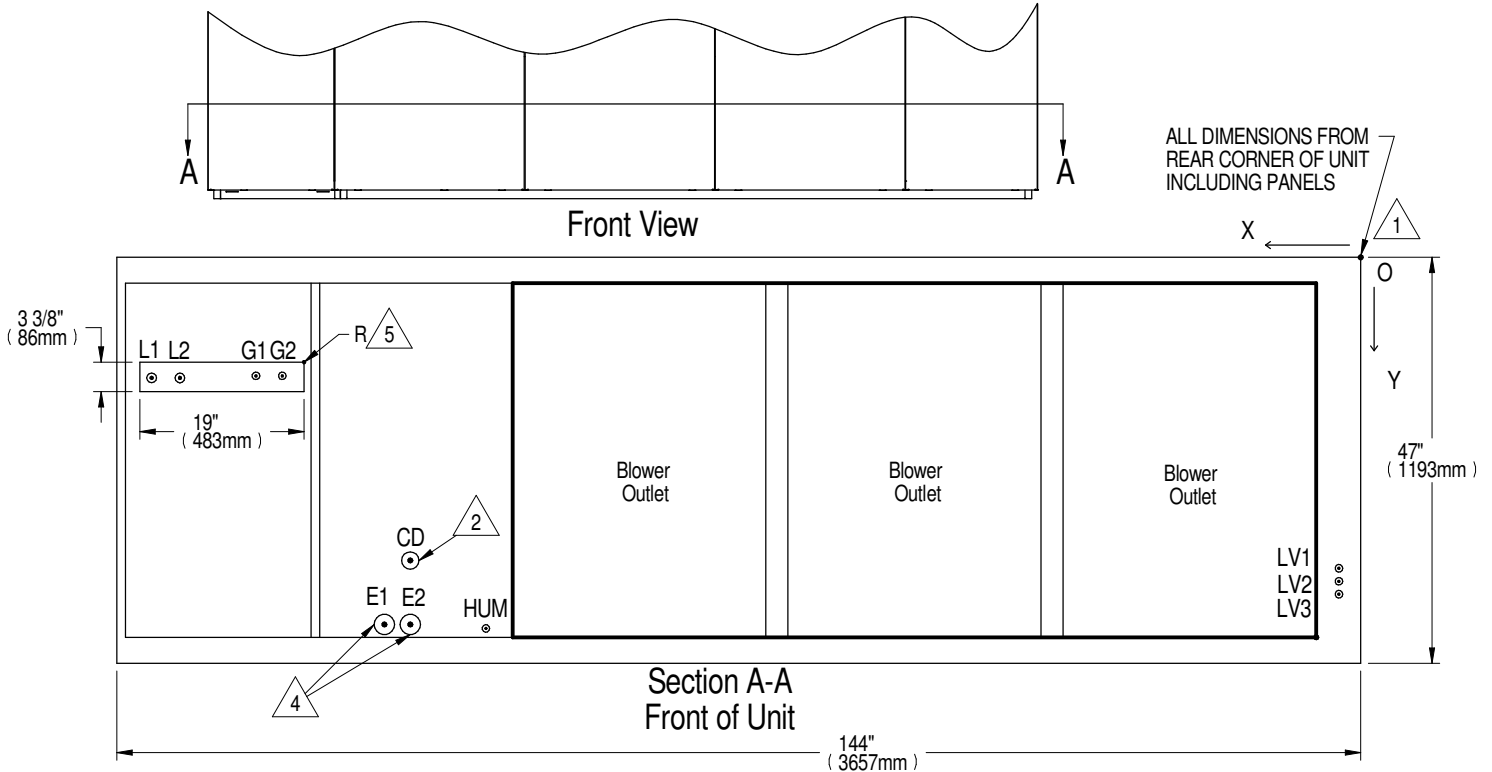

POINT	DESCRIPTION	X	Y	DX ONLY	
				CONNECTION SIZE / OPENING	DX W ECONOPHASE
R	REFRIGERANT ACCESS ⁵	122-5/16" (3106mm)	12-1/8" (333mm)	19" (483mm) x 3-3/8" (86mm)	19" (483mm) X 3-3/8" (86mm)
L1	LIQUID LINE SYSTEM 1	140" (3554mm)	14" (355mm)	1-1/8" O.D. Cu	1-1/8" O.D. Cu
L2	LIQUID LINE SYSTEM 2	136-11/16" (3471mm)	14" (355mm)	1-1/8" O.D. Cu	1-1/8" O.D. Cu
G1	HOT GAS DISCHARGE 1 ³	127-7/8" (3248mm)	13-3/4" (348mm)	1-3/8" O.D. Cu	1-3/8" O.D. Cu
G2	HOT GAS DISCHARGE 2 ³	124-3/16" (3170mm)	13-3/4" (348mm)	1-3/8" O.D. Cu	1-3/8" O.D. Cu
CD	CONDENSATE DRAIN (infrared humidifier or no humidifier) ²	110" (2794mm)	35-1/16" (891mm)	1-1/8" FPT	1-1/8" FPT
	CONDENSATE DRAIN (steam generating humidifier) ²	CONSULT FACTORY			
	W/ OPTIONAL PUMP	110" (2794mm)	35-1/16" (891mm)	1/2" O.D. Cu	1/2" O.D. Cu
HUM	HUMIDIFIER SUPPLY LINE	101-1/4" (2572mm)	43" (1091mm)	1/4" O.D. Cu	1/4" O.D. Cu
E1	ELECTRICAL CONN. (HIGH VOLT)	113" (2870mm)	42-1/2" (1080mm)	2-1/2"	2-1/2"
E2	ELECTRICAL CONN. (HIGH VOLT)	110" (2794mm)	42-1/2" (1080mm)	2-1/2"	2-1/2"
LV1	ELECTRICAL CONN. (LOW VOLT)	2-1/2" (64mm)	36" (914mm)	7/8"	7/8"
LV2	ELECTRICAL CONN. (LOW VOLT)	2-1/2" (64mm)	37-1/2" (952mm)	7/8"	7/8"
LV3	ELECTRICAL CONN. (LOW VOLT)	2-1/2" (64mm)	39" (991mm)	7/8"	7/8"

Notes:

- ¹ Drawing not to scale. All dimensions from rear corner of unit including panels, and have a tolerance of $\pm 1/2"$ (13mm).
- ² Field pitch Condensate Drain line a minimum of 1/8" (3.2 mm) per foot (305 mm). All units contain a factory installed condensate trap. Do not trap external to the unit. Select appropriate drain system materials. The drain line must comply with all local codes.
- ³ When piping out the top of the unit, install traps in the discharge lines in the bottom of the unit before running lines to the top.
- ⁴ Opening for conduit chase, E1 and E2 are openings for conduit for connections to 2-1/2", 1-3/4" and 1-3/8" knockouts at electric panel.
- ⁵ See DPN003175 for alternate piping from the top of the unit.

PIPING SCHEMATIC DA050, DA080 & DA085 MODELS W/ LIEBERT MC

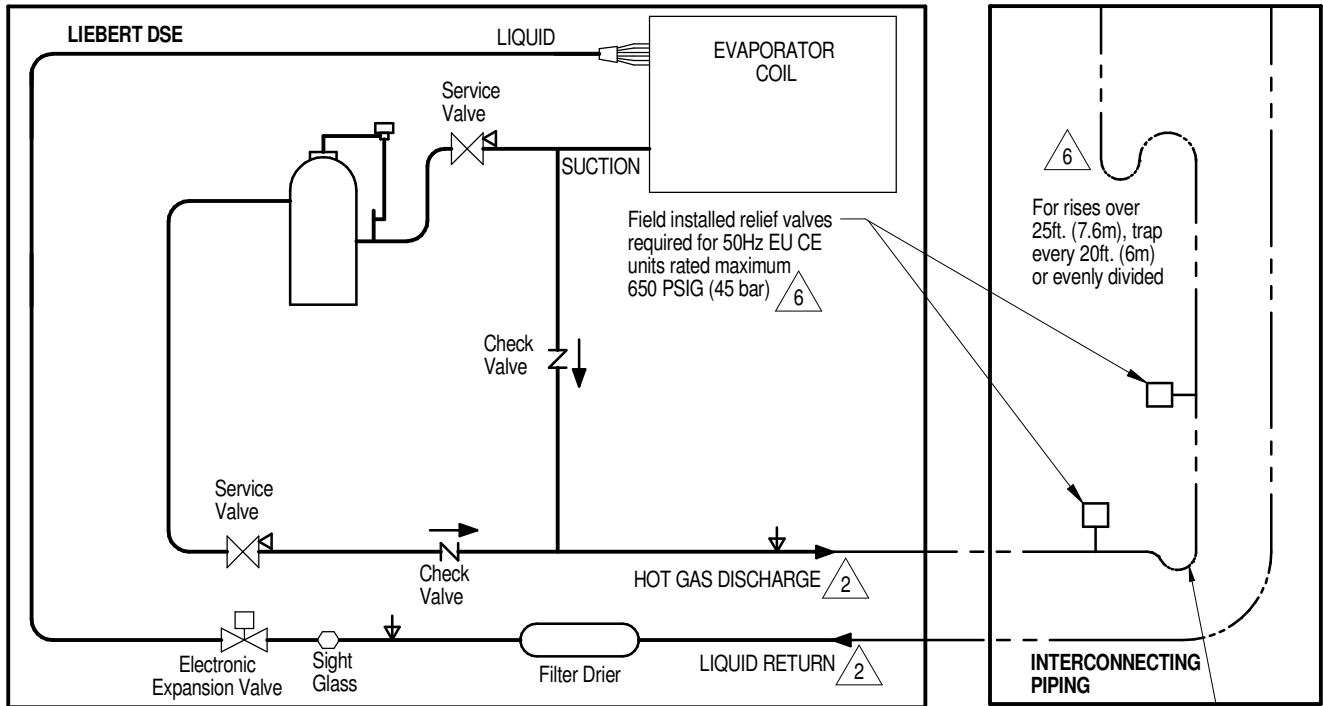
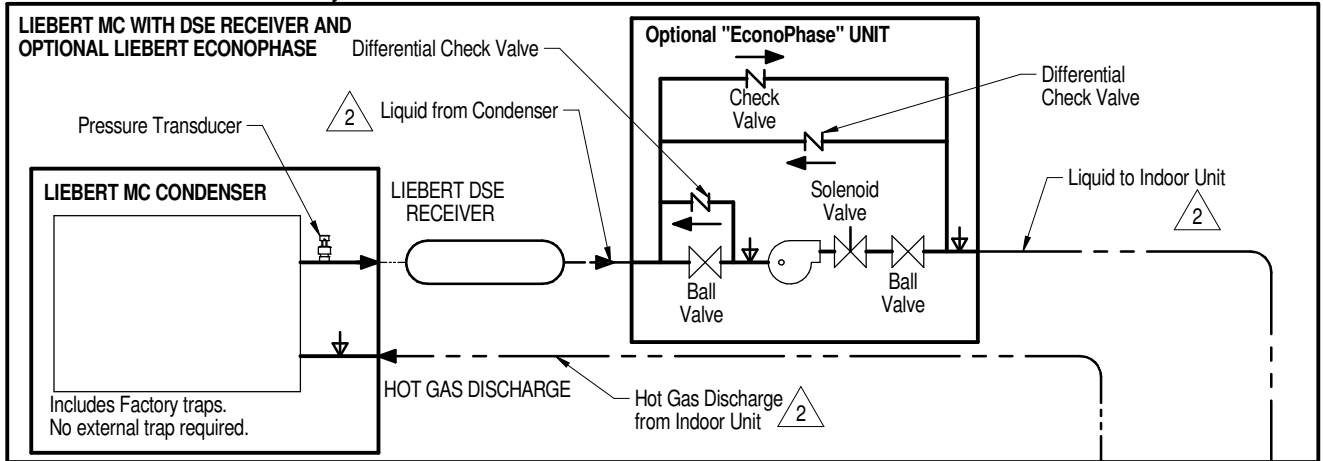

————— FACTORY REFRIGERANT PIPING
 - - - - - FIELD PIPING

▽ SERVICE/SCHRADER (ACCESS) CONNECTION, NO VALVE CORE.
 ▽ SERVICE/SCHRADER (ACCESS) CONNECTION, WITH VALVE CORE.

Notes:

1. Two refrigeration circuits provided on DA080 & DA085. Single refrigeration circuit provided on DA050. Single refrigeration circuit shown for clarity.
2. Circuit 1 must be maintained between indoor unit, condenser and EconoPhase unit. Circuit 2 must be maintained between indoor unit, condenser and EconoPhase unit.
3. Schematic representation shown. Do not use for specific connection locations.
4. The outlet of the receiver must be higher than the elevation of the EEV inside the indoor unit. This vertical height must not exceed 60ft. (18.3m). Liebert DSE Receiver required for systems with or without EconoPhase unit.
5. All indoor and outdoor field refrigerant piping must be insulated, 1/2" minimum thickness. All outdoor insulation must be UV and ozone resistant.
6. Components are not supplied by Liebert but are required for proper circuit operation and maintenance.
7. Traps must be installed and horizontal lines pitched to ensure proper oil return and to reduce liquid flood back to compressor. Pitch horizontal hot gas piping at a minimum of 1/2" per 10 feet (42mm per 10m) so that gravity will aid in moving oil in the direction of refrigeration flow.
8. Do not isolate any refrigeration circuits from over pressurization protection.

LIEBERT DSE

PIPING SCHEMATIC DA125, DA150 & DA165 W/ LIEBERT MC

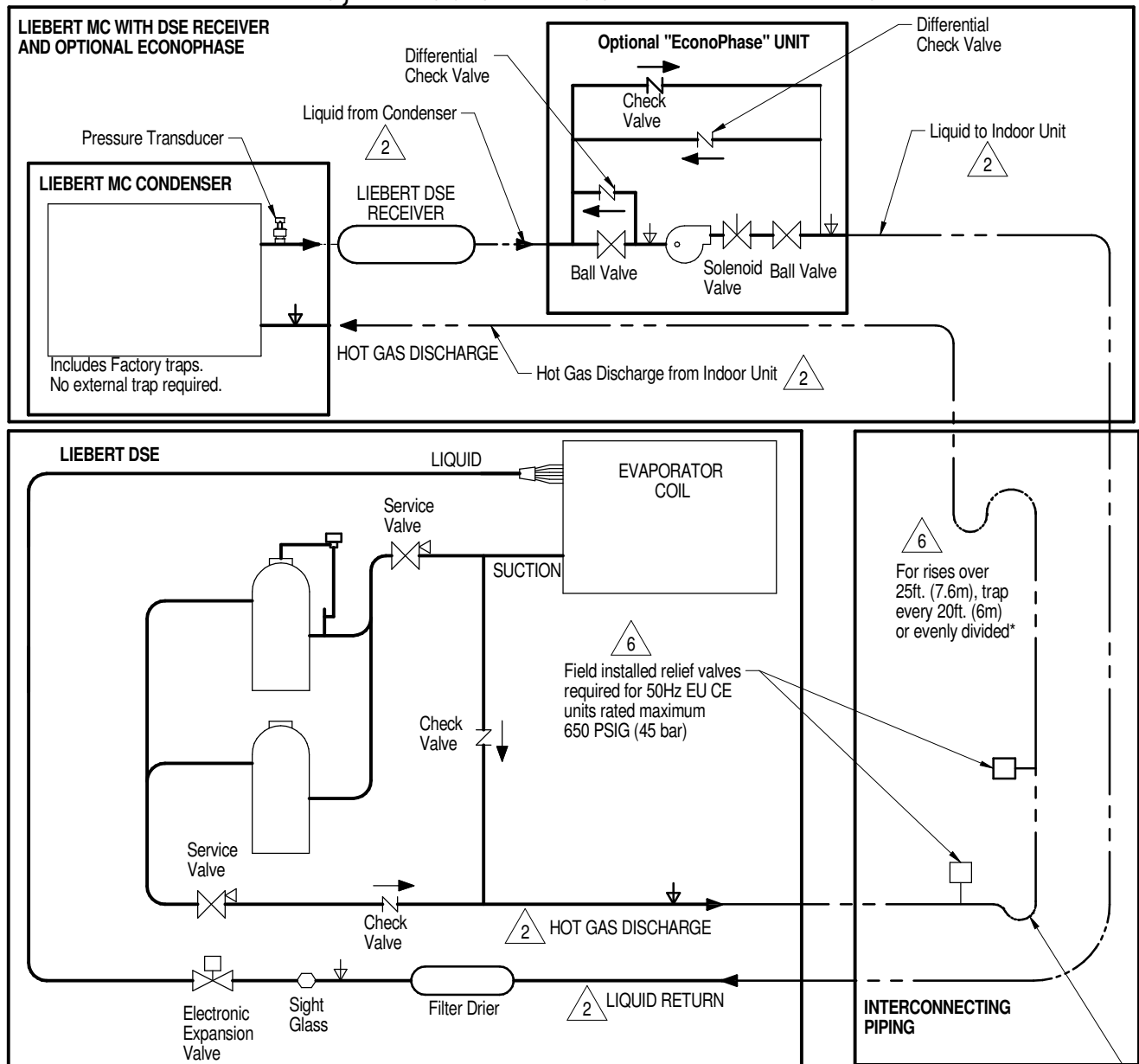



Notes:

1. Two refrigeration circuits provided. Single refrigeration circuit shown for clarity.
2. Circuit 1 must be maintained between indoor unit, condenser and EconoPhase unit. Circuit 2 must be maintained between indoor unit, condenser and EconoPhase unit.
3. Schematic representation shown. Do not use for specific connection locations.
4. The outlet of the receiver must be higher than the elevation of the EEV inside the indoor unit. This vertical height must not exceed 60ft. (18.3m). Liebert DSE Receiver required for systems with or without EconoPhase.
5. All indoor and outdoor field refrigerant piping must be insulated, 1/2" minimum thickness. All outdoor insulation must be UV and ozone resistant.
6. Components are not supplied by Liebert but are required for proper circuit operation and maintenance.
7. Traps must be installed and horizontal lines pitched to ensure proper oil return and to reduce liquid flood back to compressor. Pitch horizontal gas piping at a minimum of 1/2" per 10 feet (42mm per 10m) so that gravity will aid in moving oil in the direction of the refrigeration flow.
8. Do not isolate any refrigerant circuits from over pressurization protection.

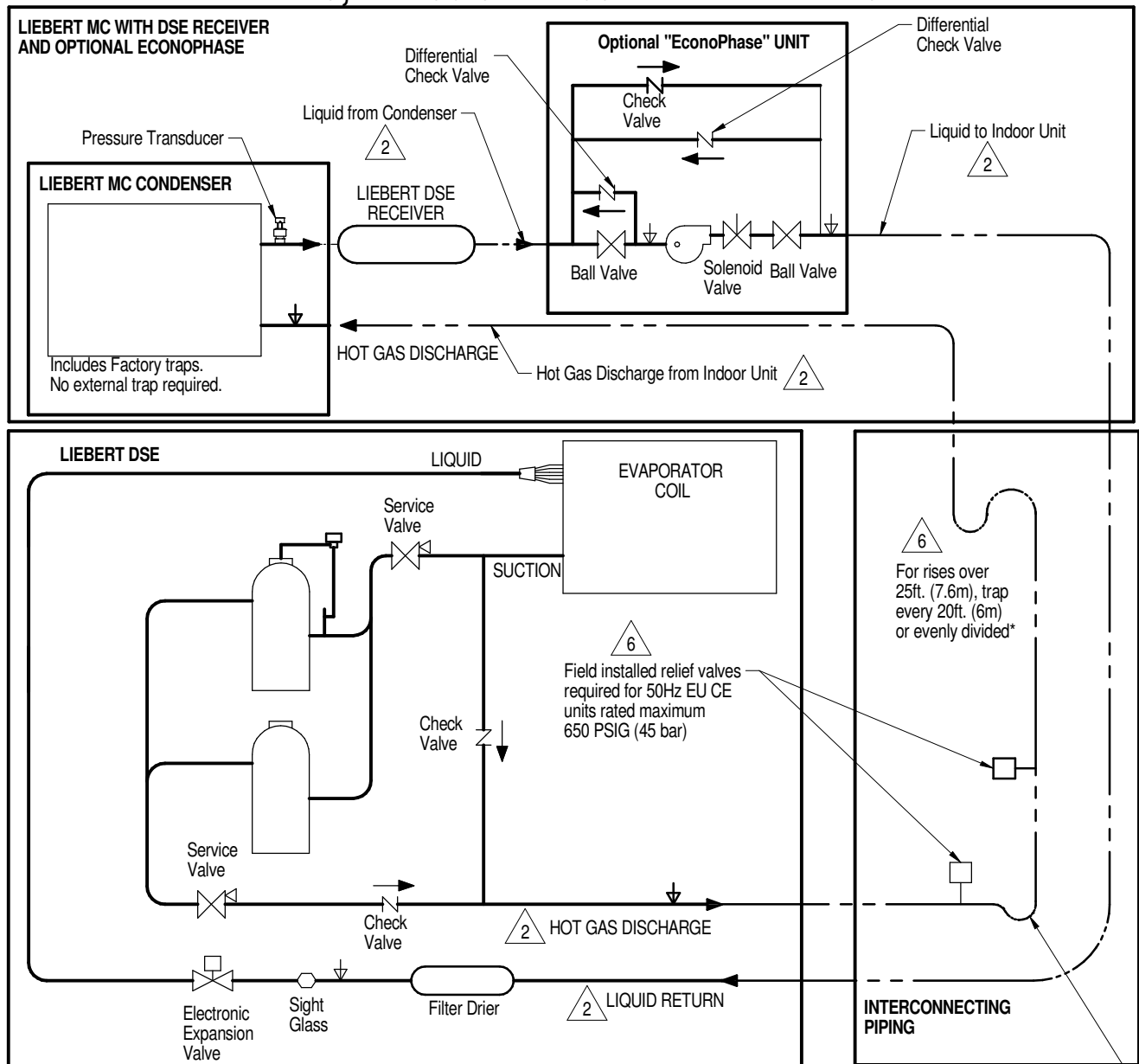
PIPING SCHEMATIC DA125, DA150 & DA165 W/ LIEBERT MC



FACTORY REFRIGERANT PIPING  SERVICE/SCHRADER (ACCESS) CONNECTION, NO VALVE CORE.
 FIELD PIPING  SERVICE/SCHRADER (ACCESS) CONNECTION, WITH VALVE CORE.  Trap at base of risers over 5ft. (1.5m)*

- Notes:
1. Two refrigeration circuits provided. Single refrigeration circuit shown for clarity.
 2. Circuit 1 must be maintained between indoor unit, condenser and EconoPhase unit. Circuit 2 must be maintained between indoor unit, condenser and EconoPhase unit.
 3. Schematic representation shown. Do not use for specific connection locations.
 4. The outlet of the receiver must be higher than the elevation of the EEV inside the indoor unit. This vertical height must not exceed 60ft. (18.3m). Liebert DSE Receiver required for systems with or without EconoPhase.
 5. All indoor and outdoor field refrigerant piping must be insulated, 1/2" minimum thickness. All outdoor insulation must be UV and ozone resistant.
 6. Components are not supplied by Liebert but are required for proper circuit operation and maintenance.
 7. Traps must be installed and horizontal lines pitched to ensure proper oil return and to reduce liquid flood back to compressor. Pitch horizontal gas piping at a minimum of 1/2" per 10 feet (42mm per 10m) so that gravity will aid in moving oil in the direction of the refrigeration flow.
 8. Do not isolate any refrigerant circuits from over pressurization protection.

PIPING SCHEMATIC

DA125, DA150, DA165 & DA250 with LIEBERT MCV

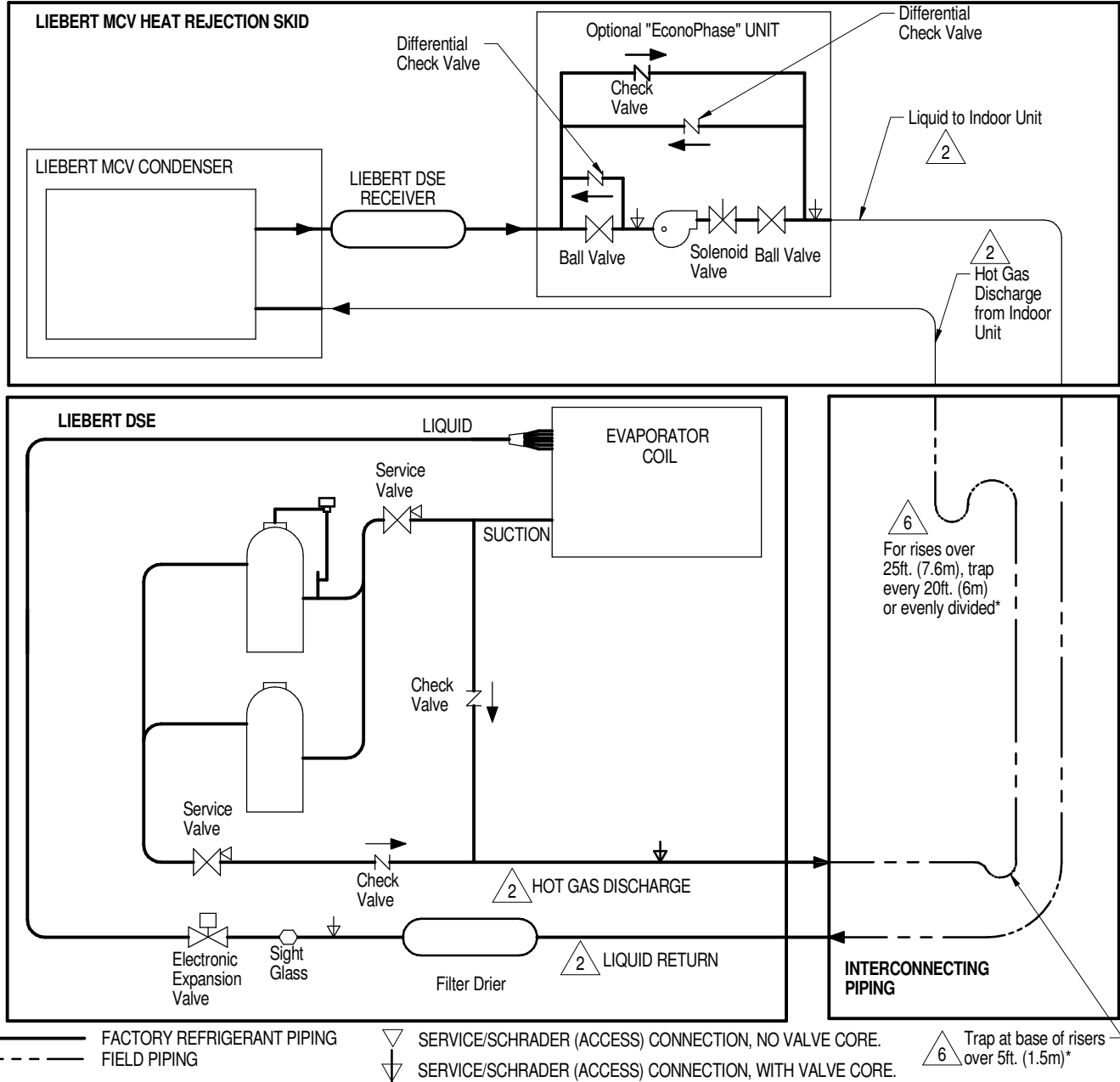

Notes:

1. Two refrigeration circuits provided. Single refrigeration circuit shown for clarity.
2. Circuit 1 must be maintained between indoor unit, condenser and EconoPhase unit. Circuit 2 must be maintained between indoor unit, condenser and EconoPhase unit.
3. Schematic representation shown. Do not use for specific connection locations.
4. The outlet of the receiver must be higher than the elevation of the EEV inside the indoor unit. This vertical height must not exceed 60ft. (18.3m). Liebert DSE Receiver required for systems with or without EconoPhase unit.
5. All indoor and outdoor field refrigerant piping must be insulated, 1/2" minimum thickness. All outdoor insulation must be UV and ozone resistant.
6. Components are not supplied by Liebert but are required for proper circuit operation and maintenance (DA250 with top piping has internally installed traps on the discharge lines).
7. Traps must be installed and horizontal lines pitched to ensure proper oil return and to reduce liquid flood back to compressor. Pitch horizontal gas piping at a minimum of 1/2" per 10 feet (42mm per 10m) so that gravity will aid in moving oil in the direction of the refrigeration flow.
8. Do not isolate any refrigeration circuits from over pressurization protection.

AIR COOLED PIPING SCHEMATIC LIEBERT MC MOUNTED ABOVE LIEBERT DA050-165

1-3/8 inch minimum diameter Liquid line.
DO NOT TRAP LINE! Slope 2 inch per
10 ft (167mm per 10 meter) down
towards EconoPhase unit.
Single Circuit system shown for clarity.

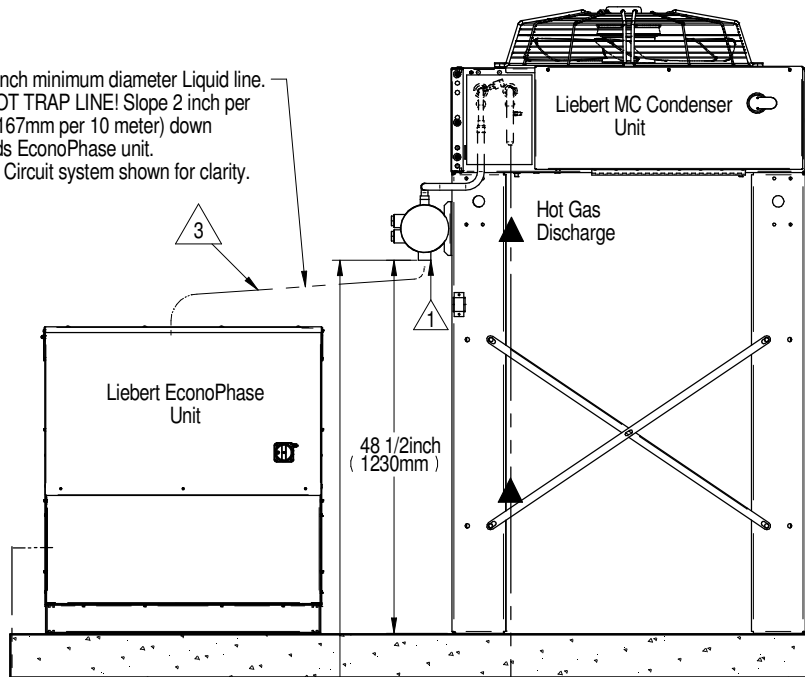

Notes:

1. The outlet of the receiver must be higher than the elevation of the EEV inside the indoor unit. The vertical height must not exceed 60 ft (18.3m).
2. For proper pump function, a minimum elevation difference of 60 inch (1524 mm) must be maintained between the bottom of condenser coil to the bottom of EconoPhase unit.
3. The maximum equivalent piping between the Liebert MC Condenser and Econophase unit is 25 ft (7.6 m). Econophase unit must be mounted outdoors for proper operation.
4. Unit must be trapped at bottom of riser with any rise over 5 feet (1.5m) high. If rise exceeds 25 feet (7.5m), then a trap is required in 20 foot (6.1m) increments or evenly divided.
5. Pitch horizontal hot gas piping at a minimum of 1/2" per 10 feet (42 mm per 10m) so that gravity will aid in moving oil in the direction of the refrigeration flow.
6. Unit piping entrance varies by unit and may be through the top of the unit.
7. All indoor and outdoor field refrigerant piping must be insulated, 1/2 inch minimum. All outdoor insulation must be UV and ozone resistant.
8. Consult factory for any exceptions to the above guidelines.

Internal EEV Height	H inch (mm)
DA050-165	43 (1092)

----- Field Piping

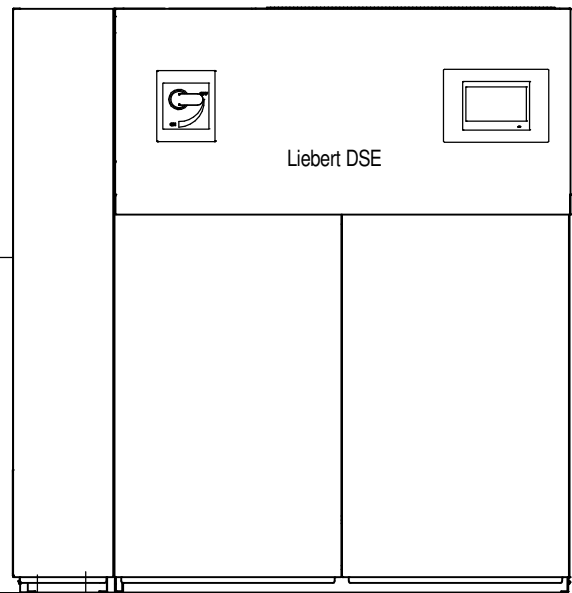
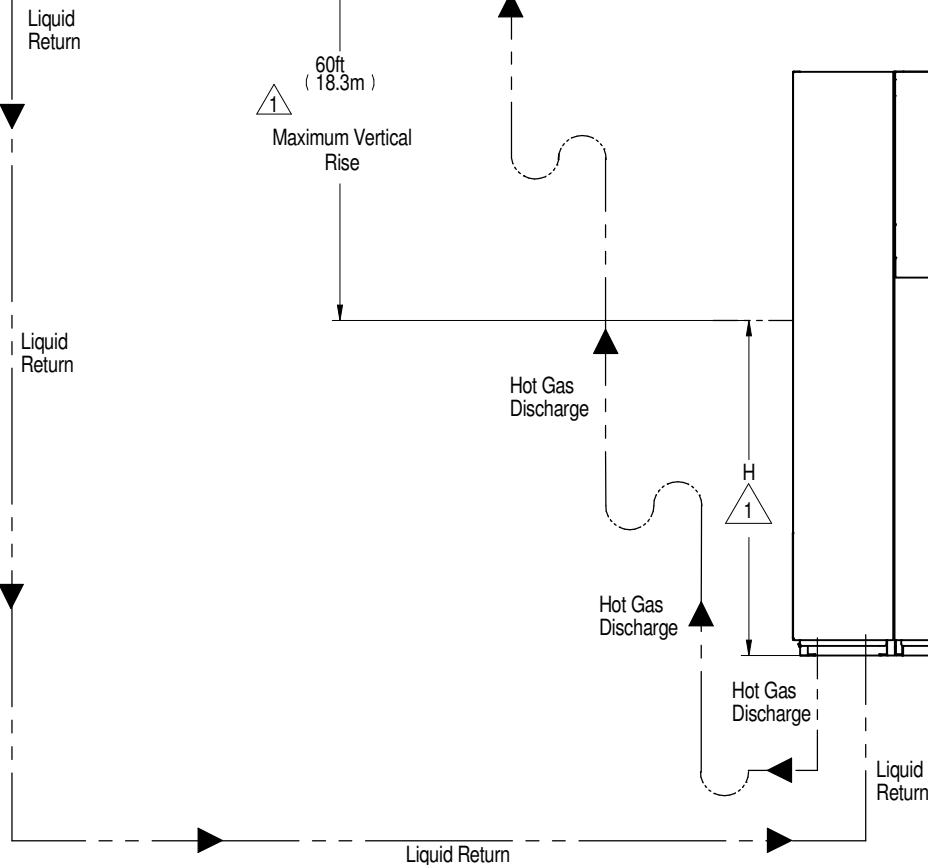

FRONT VIEW

AIR COOLED PIPING SCHEMATIC LIEBERT MC AND LIEBERT DA050-165 AT SIMILAR LEVELS

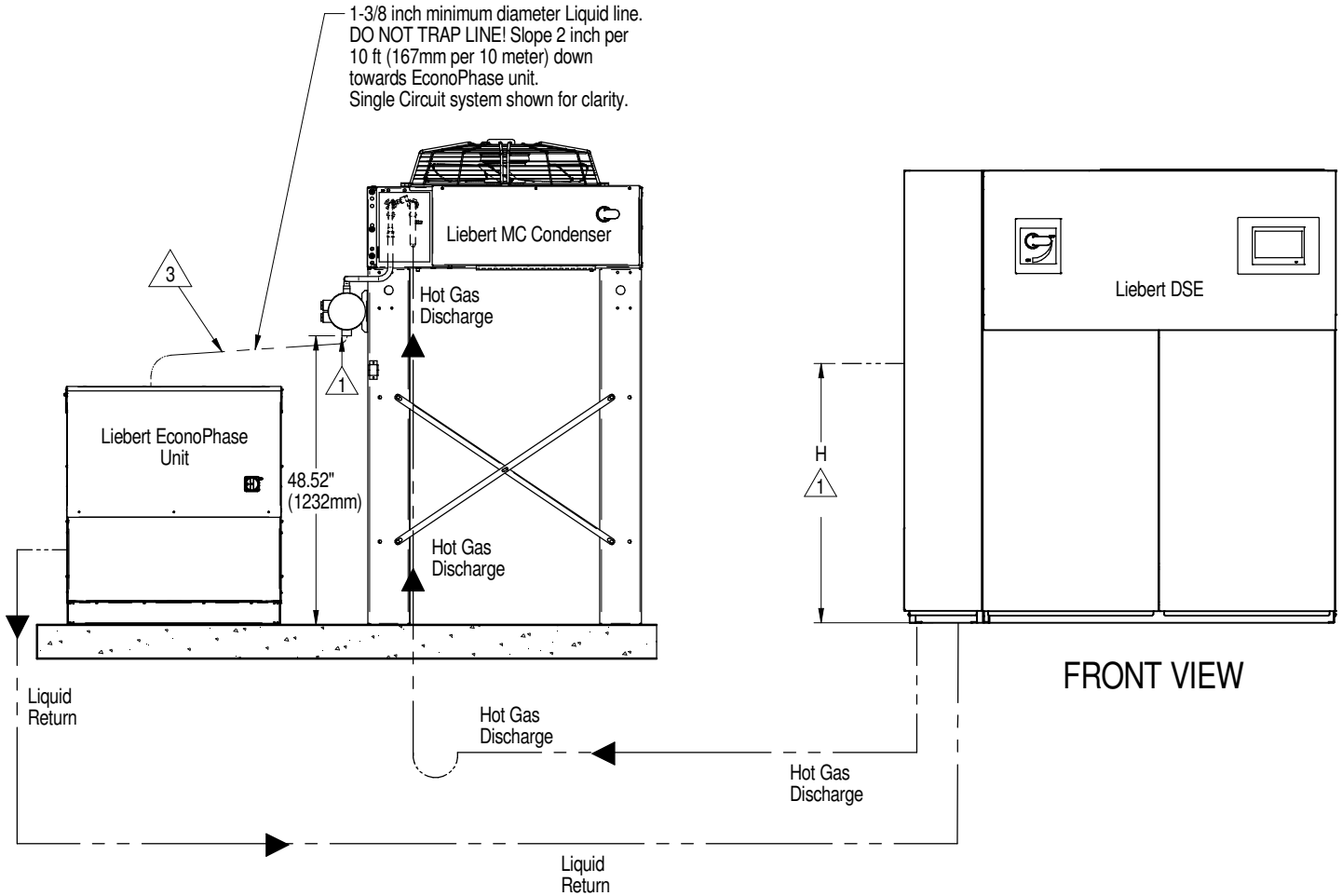

Notes:

1. The outlet of the receiver must be higher than the elevation of the EEV inside the indoor unit.
2. For proper pump function, a minimum elevation difference of 60 inch (1524 mm) must be maintained between the bottom of condenser coil to the bottom of EconoPhase unit.
3. The maximum equivalent piping between the Liebert MC Condenser and EconoPhase unit is 25 ft (7.6 m). EconoPhase unit must be mounted outdoors for proper operation.
4. Unit must be trapped at bottom of riser with any rise over 5 feet (1.5m) high. If rise exceeds 25 feet (7.5m), then a trap is required in 20 foot (6.1m) increments or evenly divided.
5. Pitch horizontal hot gas piping at a minimum of 1/2" per 10 feet (42 mm per 10m) so that gravity will aid in moving oil in the direction of the refrigeration flow.
6. Unit piping entrance varies by unit and may be through the top of the unit.
7. All indoor and outdoor field refrigerant piping must be insulated, 1/2 inch minimum. All outdoor insulation must be UV and ozone resistant.
8. Consult factory for any exceptions to the above guidelines.

LIEBERT ECONOPHASE

UNIT ARRANGEMENT DIAGRAM CONDENSER & SINGLE CIRCUIT ECONOPHASE UNIT

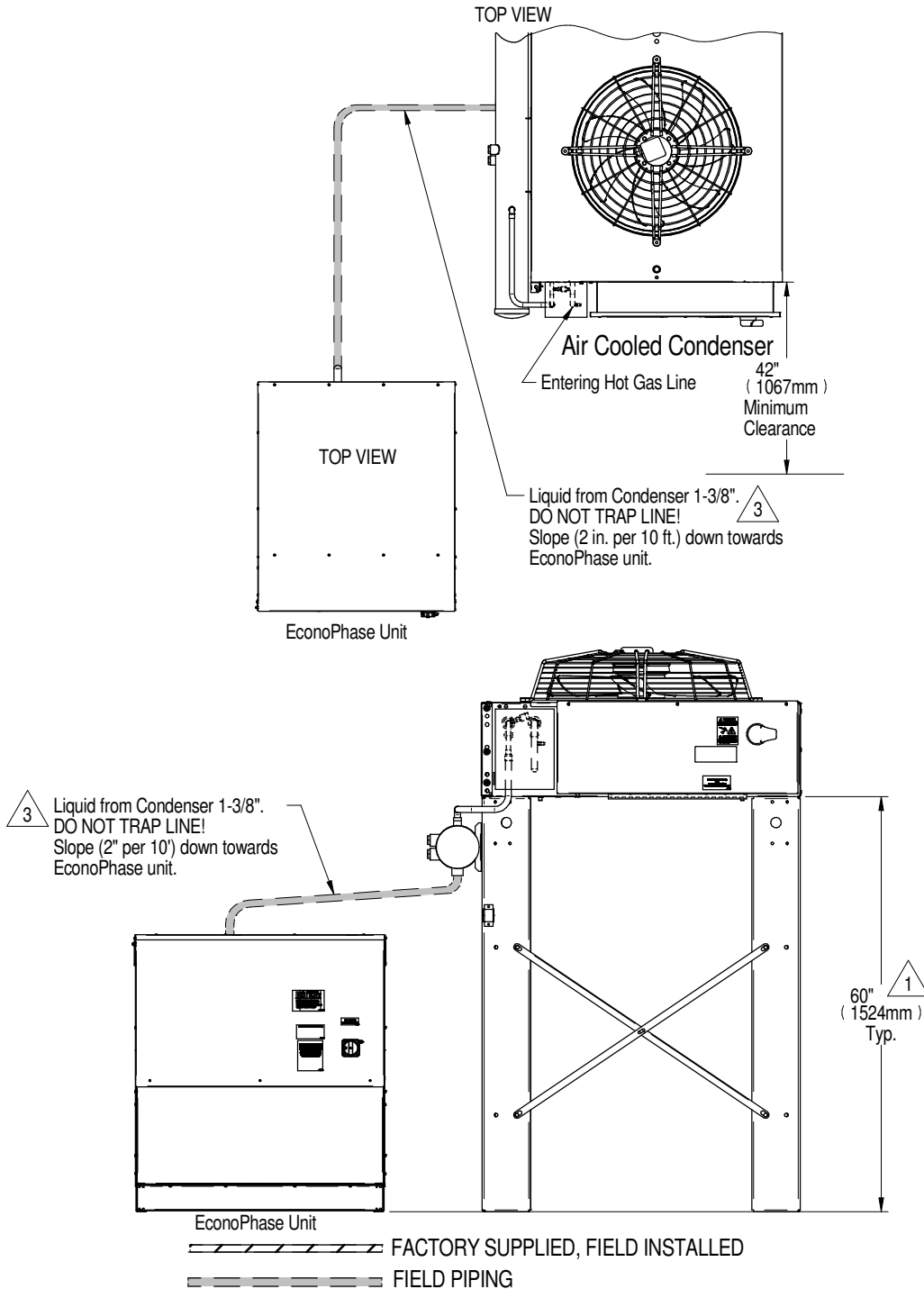

Notes:

- 1 For proper pump function, a minimum elevation difference of 60" (1524 mm) must be maintained between the bottom of condenser box to the bottom of EconoPhase unit.
2. All indoor and outdoor field refrigerant piping must be insulated, 1/2" minimum. All outdoor insulation must be UV and ozone resistant.
- 3 Components are not supplied by Liebert but are required for proper circuit operation and maintenance.
4. See DPN003994 for piping elevations.

LIEBERT ECONOPHASE

UNIT ARRANGEMENT DIAGRAM CONDENSER AND DUAL CIRCUIT ECONOPHASE UNIT

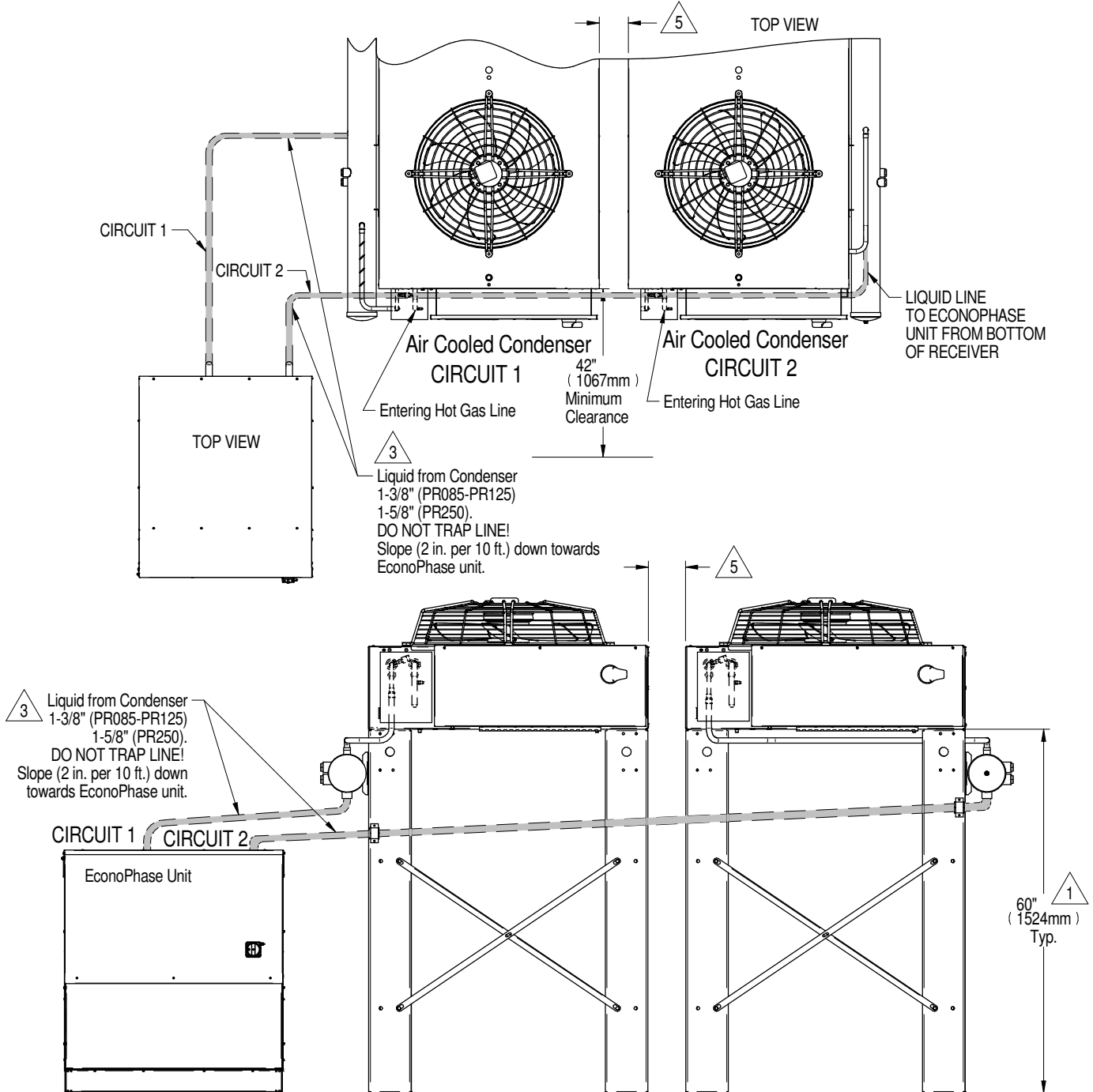





————— FACTORY SUPPLIED, FIELD INSTALLED
- - - - - FIELD PIPING

Notes:

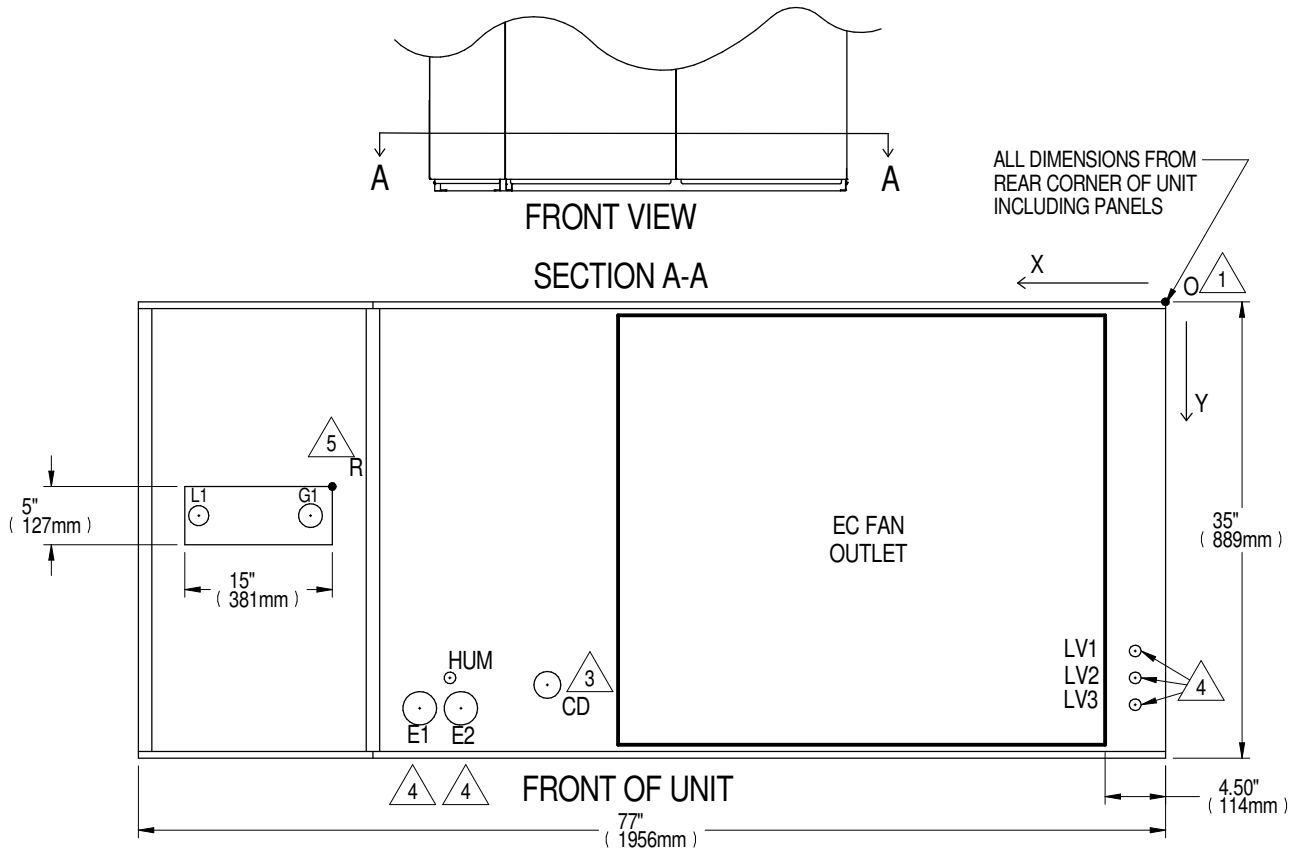



1. For proper pump function, a minimum elevation difference of 60" (1524 mm) must be maintained between the bottom of condenser box to the bottom of EconoPhase unit.
2. All indoor and outdoor field refrigerant piping must be insulated, 1/2" minimum. All outdoor insulation must be UV and ozone resistant.
3. Components are not supplied by Liebert but are required for proper circuit operation and maintenance.
4. For Piping Elevation refer to DPN003994.
5. Liebert MC Condenser with legs taller than 18" (457mm) require a minimum spacing of 6" (152mm) for leg bracing.

PRIMARY CONNECTION LOCATIONS DOWNFLOW DA050



POINT	DESCRIPTION	X in. (mm)	Y in. (mm)	CONNECTION SIZE / OPENING
R	REFRIGERANT ACCESS 	59-7/8 (1521)	13-11/16 (348)	15" (381mm) X 5" (127mm)
L1	LIQUID LINE SYSTEM 1	71-11/16 (1821)	16-3/4 (425)	5/8" O.D. Cu
G1	HOT GAS DISCHARGE 1 	62-9/16 (1589)	16-3/8 (416)	1-1/8" O.D. Cu
CD	CONDENSATE DRAIN  (infrared humidifier or no humidifier)	46 (1168)	29-1/2 (749)	3/4" NPT Female
	W/ OPTIONAL PUMP			1/2" O.D. Cu
HUM	HUMIDIFIER SUPPLY LINE	53-1/2 (1359)	29 (737)	1/4" O.D. Cu
E1	ELECTRICAL CONN. (HIGH VOLT)	55-1/2 (1410)	31-1/4 (794)	2-1/2"
E2	ELECTRICAL CONN. (HIGH VOLT)			
LV1	ELECTRICAL CONN. (LOW VOLT)	2-1/4 (57)	27 (686)	7/8"
LV2	ELECTRICAL CONN. (LOW VOLT)		29 (737)	
LV3	ELECTRICAL CONN. (LOW VOLT)		31 (787)	

Notes:

-  Drawing not to scale. All dimensions from rear corner of unit including panels, and have a tolerance of ±1/2" (13mm).
-  Field pitch Condensate Drain line a minimum of 1/8" (3.2 mm) per foot (305 mm). All units contain a factory installed condensate trap. Do not trap external to the unit. Select appropriate drain system materials. The drain line must comply with all local codes.
-  When piping out of the top of the unit, install traps in the discharge lines in the bottom of the unit before running lines to the top.
-  Opening for conduit chase, E1 and E2 are openings for conduit connections to 2-1/2", 1-3/4" and 1-3/8" knockouts at electric panel.
-  See DPN003533 for alternate piping from the top of the unit.

PRIMARY CONNECTION LOCATIONS DOWNFLOW DA080-DA085 SCROLL OR DIGITAL SCROLL COMPRESSOR MODELS

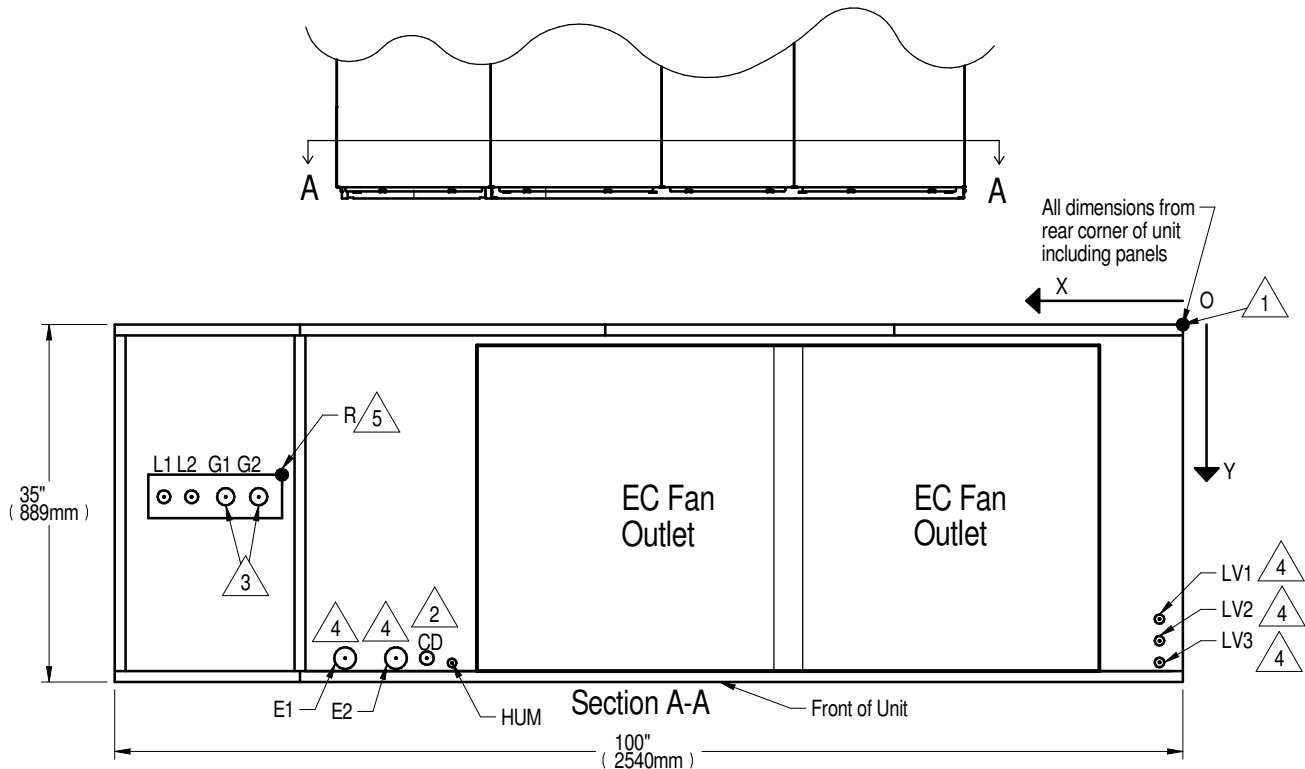

POINT	DESCRIPTION	X in. (mm)	Y in. (mm)	CONNECTION SIZE / OPENING
R	REFRIGERANT ACCESS ⁵	82-7/8 (2105)	13-11/16 (348)	15" (379mm) X 5" (127mm)
L1	LIQUID LINE SYSTEM 1	94-11/16 (2405)	16-3/4 (425)	5/8" O.D. Cu
L2	LIQUID LINE SYSTEM 2	91-7/8 (2334)		
G1	HOT GAS DISCHARGE 1 ³	88-3/4 (2254)	16-3/8 (416)	1-1/8" O.D. Cu
G2	HOT GAS DISCHARGE 2 ³	85-9/16 (2173)		
CD	CONDENSATE DRAIN ² (infrared humidifier or no humidifier)	68-3/8 (1737)	31-3/8 (797)	3/4" NPT FEMALE
	W/ OPTIONAL PUMP			1/2" O.D. Cu
HUM	HUMIDIFIER SUPPLY LINE	76-1/2 (1943)	29 (737)	1/4" O.D. Cu
E1	ELECTRICAL CONN. (HIGH VOLT)	78-1/2 (1994)	31-1/8 (791)	2-1/2"
E2		75-3/8 (1915)		
LV1	ELECTRICAL CONN. (LOW VOLT) ⁴	2 (51)	29 (737)	7/8"
LV2			30-7/8 (784)	
LV3			32 (813)	

Notes:

- ¹ Drawing not to scale. All dimensions from rear corner of unit including panels, and have a tolerance of $\pm 1/2"$ (13mm).
- ² Field pitch Condensate Drain line a minimum of 1/8" (3.2 mm) per foot (305 mm). All units contain a factory installed condensate trap. Do not trap external to the unit. Select appropriate drain system materials. The drain line must comply with all local codes.
- ³ When piping out the top of the unit, install traps in the discharge lines in the bottom of the unit before running lines to the top.
- ⁴ Opening for conduit chase, E1 and E2 are openings for conduit for connections to 2-1/2", 1-3/4", and 1-3/8" knockouts at electric panel.
- ⁵ See DPN004083 for alternate piping from the top of the unit. Alternate access is available on all units except 575V.

PRIMARY CONNECTION LOCATIONS DOWNFLOW AIR COOLED DA125 MODELS WITH AND WITHOUT ECONOPHASE

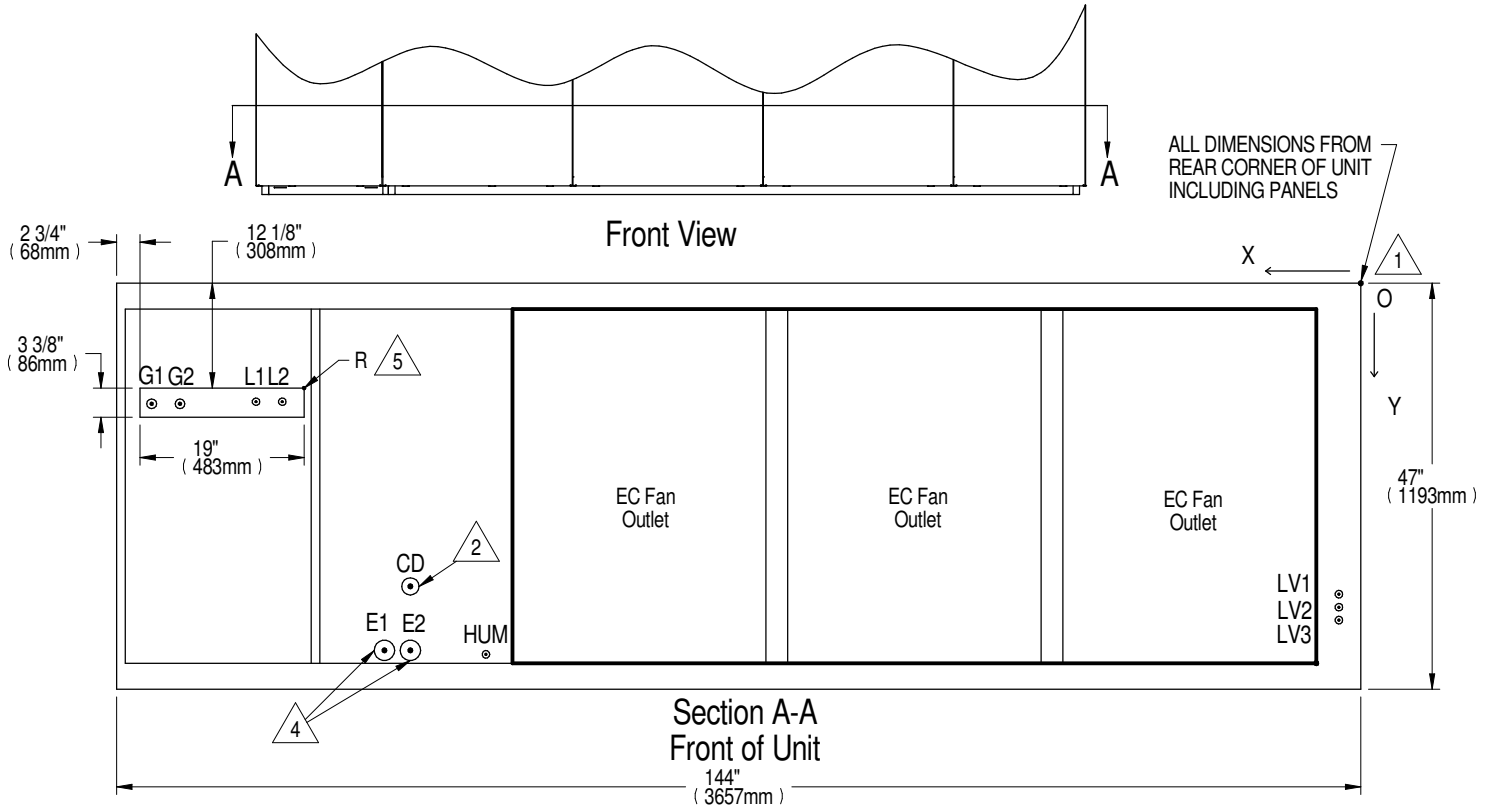

POINT	DESCRIPTION	X	Y	DX ONLY	
				CONNECTION SIZE / OPENING	
				DX W/ ECONOPHASE	
R	REFRIGERANT ACCESS ⁵	122-5/16" (3106mm)	12-1/8" (333mm)	19" (483mm) X 3-3/8" (86mm)	
L1	LIQUID LINE SYSTEM 1	127-7/8" (3248mm)	13-3/4" (348mm)	7/8" O.D. Cu	
L2	LIQUID LINE SYSTEM 2	124-13/16" (3170mm)	13-3/4" (348mm)	7/8" O.D. Cu	
G1	HOT GAS DISCHARGE 1 ³	140" (3554mm)	14" (355mm)	1-1/8" O.D. Cu	
G2	HOT GAS DISCHARGE 2 ³	136-11/16" (3471mm)	14" (355mm)	1-1/8" O.D. Cu	
CD	CONDENSATE DRAIN (infrared humidifier or no humidifier) ²	110" (2794mm)	35-1/16" (891mm)	1-1/8" NPT Female	
	W/ OPTIONAL PUMP	110" (2794mm)	35-1/16" (891mm)	1/2" O.D. Cu	
HUM	HUMIDIFIER SUPPLY LINE	101-1/4" (2572mm)	43" (1091mm)	1/4" O.D. Cu	
E1	ELECTRICAL CONN. (HIGH VOLT)	113" (2870mm)	42-1/2" (1080mm)	2-1/2"	
E2	ELECTRICAL CONN. (HIGH VOLT)	110" (2794mm)	42-1/2" (1080mm)	2-1/2"	
LV1	ELECTRICAL CONN. (LOW VOLT)	2-1/2" (64mm)	36" (914mm)	7/8"	
LV2	ELECTRICAL CONN. (LOW VOLT)	2-1/2" (64mm)	37-1/2" (952mm)	7/8"	
LV3	ELECTRICAL CONN. (LOW VOLT)	2-1/2" (64mm)	39" (991mm)	7/8"	

Notes:

- ¹ Drawing not to scale. All dimensions from rear corner of unit including panels, and have a tolerance on all piping dimensions is $\pm 1/2"$ (13mm).
- ² Field pitch Condensate Drain line a minimum of 1/8" (3.2 mm) per foot (305 mm). All units contain a factory installed condensate trap. Do not trap external to the unit. Select appropriate drain system materials. The drain line must comply with all local codes.
- ³ When piping out the top of the unit, install traps in the discharge lines in the bottom of the unit before running lines to the top.
- ⁴ Opening for conduit chase, E1 and E2 are openings for conduit for connections to 2-1/2", 1-3/4" and 1-3/8" knockouts at electric panel.
- ⁵ See DPN003175 for alternate piping from top of unit.

PRIMARY CONNECTION LOCATIONS DOWNFLOW AIR COOLED DA150 & DA165 MODELS WITH AND WITHOUT ECONOPHASE

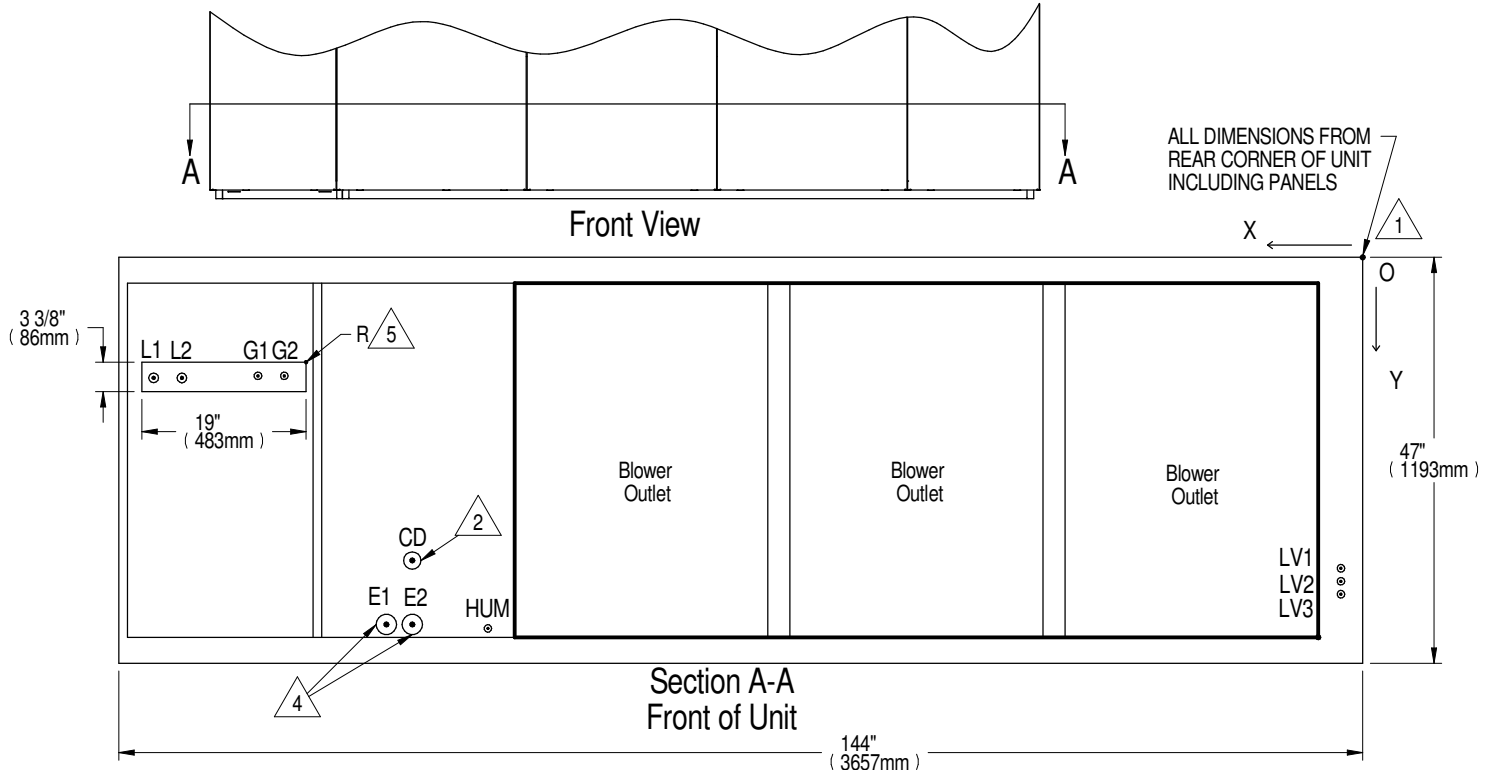

POINT	DESCRIPTION	X	Y	DX ONLY	
				CONNECTION SIZE / OPENING	DX W ECONOPHASE
R	REFRIGERANT ACCESS ⁵	122-5/16" (3106mm)	12-1/8" (333mm)	19" (483mm) x 3-3/8" (86mm)	19" (483mm) X 3-3/8" (86mm)
L1	LIQUID LINE SYSTEM 1	140" (3554mm)	14" (355mm)	1-1/8" O.D. Cu	1-1/8" O.D. Cu
L2	LIQUID LINE SYSTEM 2	136-11/16" (3471mm)	14" (355mm)	1-1/8" O.D. Cu	1-1/8" O.D. Cu
G1	HOT GAS DISCHARGE 1 ³	127-7/8" (3248mm)	13-3/4" (348mm)	1-3/8" O.D. Cu	1-3/8" O.D. Cu
G2	HOT GAS DISCHARGE 2 ³	124-3/16" (3170mm)	13-3/4" (348mm)	1-3/8" O.D. Cu	1-3/8" O.D. Cu
CD	CONDENSATE DRAIN (infrared humidifier or no humidifier) ²	110" (2794mm)	35-1/16" (891mm)	1-1/8" FPT	1-1/8" FPT
	CONDENSATE DRAIN (steam generating humidifier) ²	CONSULT FACTORY			
	W/ OPTIONAL PUMP	110" (2794mm)	35-1/16" (891mm)	1/2" O.D. Cu	1/2" O.D. Cu
HUM	HUMIDIFIER SUPPLY LINE	101-1/4" (2572mm)	43" (1091mm)	1/4" O.D. Cu	1/4" O.D. Cu
E1	ELECTRICAL CONN. (HIGH VOLT)	113" (2870mm)	42-1/2" (1080mm)	2-1/2"	2-1/2"
E2	ELECTRICAL CONN. (HIGH VOLT)	110" (2794mm)	42-1/2" (1080mm)	2-1/2"	2-1/2"
LV1	ELECTRICAL CONN. (LOW VOLT)	2-1/2" (64mm)	36" (914mm)	7/8"	7/8"
LV2	ELECTRICAL CONN. (LOW VOLT)	2-1/2" (64mm)	37-1/2" (952mm)	7/8"	7/8"
LV3	ELECTRICAL CONN. (LOW VOLT)	2-1/2" (64mm)	39" (991mm)	7/8"	7/8"

Notes:

- ¹ Drawing not to scale. All dimensions from rear corner of unit including panels, and have a tolerance of $\pm 1/2"$ (13mm).
- ² Field pitch Condensate Drain line a minimum of 1/8" (3.2 mm) per foot (305 mm). All units contain a factory installed condensate trap. Do not trap external to the unit. Select appropriate drain system materials. The drain line must comply with all local codes.
- ³ When piping out the top of the unit, install traps in the discharge lines in the bottom of the unit before running lines to the top.
- ⁴ Opening for conduit chase, E1 and E2 are openings for conduit for connections to 2-1/2", 1-3/4" and 1-3/8" knockouts at electric panel.
- ⁵ See DPN003175 for alternate piping from the top of the unit.

PRIMARY CONNECTION LOCATIONS UPFLOW DA08-DA085

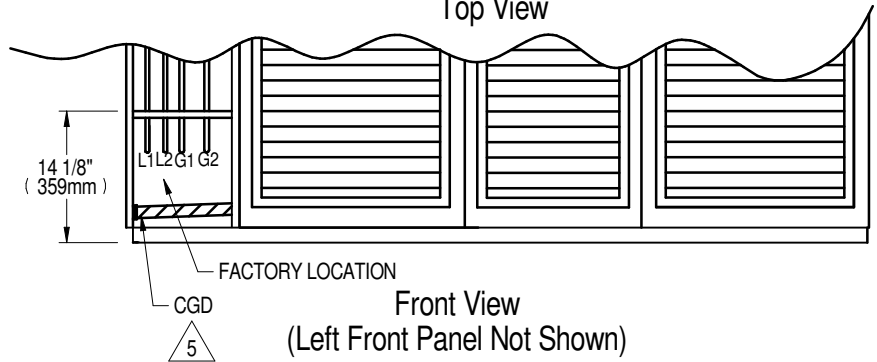
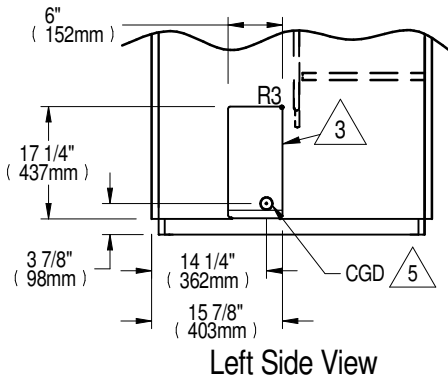
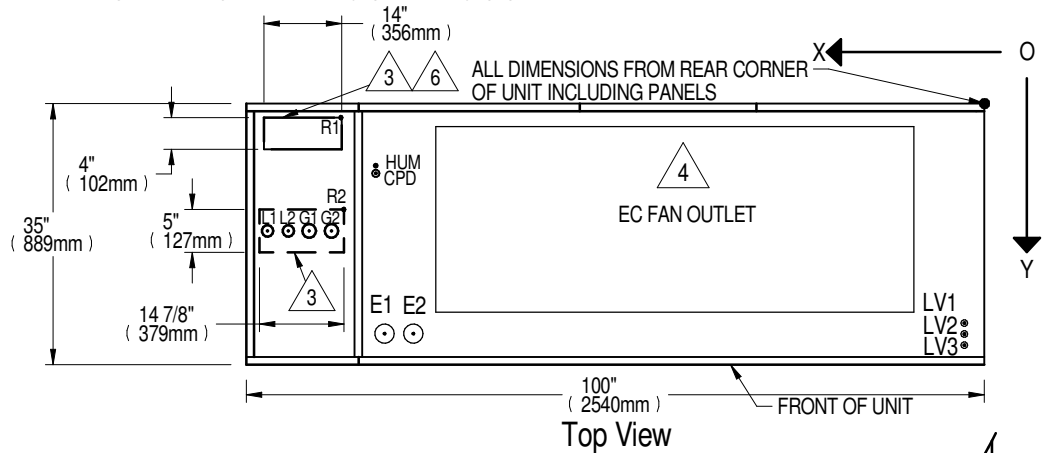

POINT	DESCRIPTION	X in. (mm)	Y in. (mm)	CONNECTION SIZE / OPENING
R1	SECONDARY REFRIGERANT ACCESS (TOP) ³	83-5/8 (2124)	1-7/8 (48)	15-7/16"(392mm) X 4" (102mm)
R2	REFRIGERANT ACCESS (BOTTOM) ³	82-15/16 (2106)	13-5/8 (346)	14-15/16" (379mm) X 5" (127mm)
R3	REFRIGERANT ACCESS (SIDE) ³	N/A		6" (152mm) X 17-3/16" (437mm)
L1	LIQUID LINE SYSTEM 1	94-9/16 (2402)	16-3/4 (425)	5/8" O.D. Cu
L2	LIQUID LINE SYSTEM 2	91-7/8 (2334)		
G1	HOT GAS DISCHARGE 1	88-7/8 (2257)	16-7/16 (418)	1-1/8" O.D. Cu
G2	HOT GAS DISCHARGE 2	85-5/8 (2175)		
CGD	CONDENSATE GRAVITY DRAIN ⁵	N/A		3/4" NPT Female
CPD	CONDENSATE PUMP DISCHARGE (OPT)	79-5/16 (2015)	11-7/8 (302)	1/2" O.D. Cu
HUM	HUMIDIFIER SUPPLY LINE		9-7/8 (251)	1/4" O.D. Cu
E1	ELECTRICAL CONN. (HIGH VOLT)	78-1/8 (1984)	30 (762)	2-1/2"
E2		74-3/8 (1889)		
LV1	ELECTRICAL CONN. (LOW VOLT)	2-5/8 (66)	29-1/16 (738)	7/8"
LV2			30-7/16 (773)	
LV3			31-13/16 (808)	

Notes:

- Drawing not to scale.
- Tolerance on all piping dimensions is $\pm 1/2"$ (13mm).

³ Field routed alternatives for refrigerant gas and liquid line connection points.

⁴ See submittal page DPN004084 for plenum dimensional data.

⁵ Field pitch Condensate Drain line a minimum of 1/8" (3.2 mm) per foot (305 mm). All units contain a factory installed condensate trap. Do not trap external to the unit. Select appropriate drain system materials. The drain line must comply with all local codes

⁶ Secondary Refrigerant Access (R1). Not available with 575V.



LIEBERT DSE

ELECTRICAL FIELD CONNECTION DESCRIPTION 50kW - 85kW UPFLOW AND DOWNFLOW MODELS

STANDARD ELECTRICAL CONNECTIONS

- 1) **Primary high voltage entrance** - 2.50" (64mm); 1.75" (44mm); 1.375" (35mm) diameter concentric knockouts located in bottom of box
- 2) **Secondary high voltage entrance** - 2.50" (64mm); 1.75" (44mm); 1.375" (35mm) diameter concentric knockouts located in top of box
- 3) **Primary low voltage entrance** - Quantity (3) 1.375" (35mm) diameter knockouts located in bottom of unit
- 4) **Secondary low voltage entrance** - Quantity (3) 1.375" (35mm) diameter knockouts located in top of box
- 5) **Three phase electrical service** - Terminals are on main fuse block (disregard if unit has optional disconnect switch). Three phase service not by Liebert.
- 6) **Earth ground** - Terminal for field supplied earth grounding wire. Earth grounding required for Liebert units.
- 7) **Remote unit shutdown** - Replace existing jumper between terminals 37 & 38 with field supplied normally closed switch having a minimum 75VA, 24VAC rating. Use field supplied Class 1 wiring.
- 8) **Customer alarm inputs** - Terminals for field supplied, normally open contacts, having a minimum 75VA, 24VAC rating, between terminals 24 & 50, 51, 55, 56. Use field supplied Class 1 wiring. Terminal availability varies by unit options.
- 9) **Common alarm** - On any alarm, normally open dry contact is closed across terminals 75 & 76 for remote indication. 1 AMP, 24VAC max load. Use Class 1 field supplied wiring.
- 10) **Heat rejection interlock** - On any call for compressor operation, normally open dry contact is closed across terminals 70 & 71(circuit 1), 230 (circuit 2) to heat rejection equipment. 1 AMP, 24VAC max load. Use Class 1 field supplied wiring. Liebert DSE units must be connected to Liebert MC series condenser with premium control. It is required that the jumper between terminal 71 and terminal 230 be removed. Three wires must connect terminals 70, 71, and 230 of the indoor unit to terminals 70, 71 and 230 of the Liebert MC series condenser.
- 11) **Unit factory installed disconnect switch, Fuse Block and Main Fuses** – "Locking Type" consists of a non-automatic molded case switch operational from the outside of the unit. Access to the high voltage electric panel compartment can be obtained only with the switch in the "off" position. Units with fused disconnects are provided with a defeater button that allows access to the electrical panel when power is on. The molded case switch disconnect models contain separate main fuses

CANBUS ELECTRICAL CONNECTIONS

- 12) **CANbus Connector**– Terminal block with terminals 49-1 (CAN-H) and 49-3 (CAN-L) + SH (shield connection). The terminals are used to connect the CANbus communication cable (provided by others) from the indoor unit to the Liebert MC Condenser –Optional Econophase Unit.
- 13) **CANbus Cable** – CANbus cable provided by others to connect to the outdoor condenser, and optional PRE unit (DA units only). No special considerations are required when the total external cable connection between the indoor unit and outdoor unit(s) is less than 450FT (137M). For total external cable connections greater than 450FT (137M) but less than 800FT (243M) a CANbus isolator is required (Contact Factory).
Cable must have the following specifications:
 - Braided shield or foil shield with drain wire
 - Shield must be wired to ground at indoor unit
 - 22-18AWG stranded tinned copper
 - Twisted pair (minimum 4 twists per foot)
 - Low Capacitance (15pF/FT or less)
 - Must be rated to meet local codes and conditions
 - EXAMPLES BELDEN 89207 (PLENUM RATED), OR ALPHA WIRE 6454 CATEGORY 5, 5E, OR HIGHER
- 14) Do not run in same conduit, raceway, or chase as high voltage wiring.
- 15) For CANbus network lengths greater than 450FT (137M) call Factory.



LIEBERT DSE

ELECTRICAL FIELD CONNECTION DESCRIPTION

50kW - 85kW UPFLOW AND DOWNFLOW MODELS

OPTIONAL ELECTRICAL CONNECTIONS

- 16) **Smoke sensor alarm - Factory** wired dry contacts from smoke sensor are 91-common, 92-NO, and 93-NC. Supervised contacts, 80 & 81, open on sensor trouble indication. This smoke sensor is not intended to function as, or replace, any room smoke detection system that may be required by local or national codes. 1 AMP, 24VAC max load. Use Class 1 field supplied wiring.
- 17) **Reheat and humidifier lockout** - Remote 24VAC required at terminals 82 & 83 for lockout of reheat and humidifier.
- 18) **Condensate alarm** (with condensate pump option) - On pump high water indication, normally open dry contact is closed across terminals 88 & 89 for remote indication. 1 AMP, 24VAC max load. Use Class 1 field supplied wiring.
- 19) **Remote humidifier** - On any call for humidification, normally open dry contact is closed across terminals 11 & 12 to signal field supplied remote humidifier. 1 AMP, 24VAC max load. Use Class 1 field supplied wiring.
- 20) **Analog Inputs**- Terminals 41, 42, 43, 44 are user configurable for 0-10V, 0-5V, or 4-20MA.

OPTIONAL LOW VOLTAGE TERMINAL PACKAGE CONNECTIONS

- 21) **Remote unit shutdown** - Two additional contact pairs available for unit shutdown (labeled as 37B & 38B, 37C & 38C). Replace jumpers with field supplied normally closed switch having a minimum 75VA, 24VAC rating. Use field supplied Class 1 wiring.
- 22) **Common alarm** - On any alarm, two additional normally open dry contacts are closed across terminals 94 & 95 and 96 & 97 for remote indication. 1 AMP, 24VAC max load. Use Class 1 field supplied wiring.
- 23) **Main fan auxiliary switch** - On closure of main fan contactor, normally open dry contact is closed across terminals 84 & 85 for remote indication. 1 AMP, 24VAC max load. Use Class 1 field supplied wiring.
- 24) **Liqui-Tect shutdown and dry contact** - On Liqui-Tect activation, normally open dry contact is closed across terminals 58 & 59 for remote indication (LiquiTect sensor ordered separately). 1 AMP, 24VAC max load. Use Class 1 field supplied wiring.

OPTIONAL COMMUNICATION CONNECTIONS.

- 25) **Unit-To-Unit** – Plug 64 is reserved for U2U communication.
- 26) **Site and BMS** - Plug 74 and terminal block 3 are reserved for Site and BMS connections. Plug 74 is an eight pin RJ45 for a Cat 5 cable. Terminal block 3 is a two position screw terminal block for use with twisted pair wires.

NOTE: Refer to specification sheet for total unit full load amps, wire size amps, and max overcurrent protective device size.

ELECTRICAL FIELD CONNECTION DESCRIPTION 50kW - 85kW UPFLOW AND DOWNFLOW MODELS

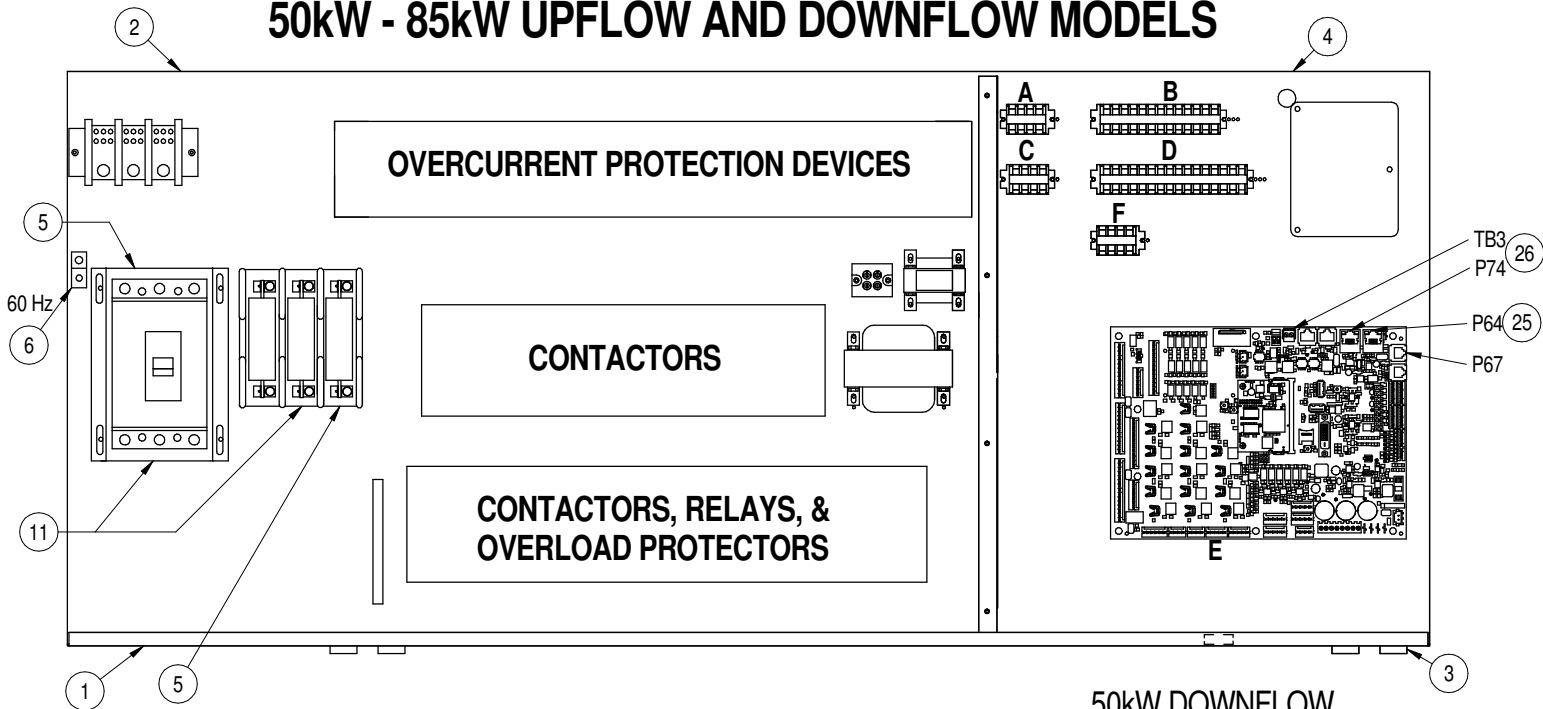

Note: Typical orientation of components shown. Component location varies by option and unit size.

50kW DOWNFLOW
80kW - 85kW UPFLOW AND DOWNFLOW
LOW VOLT SECTION

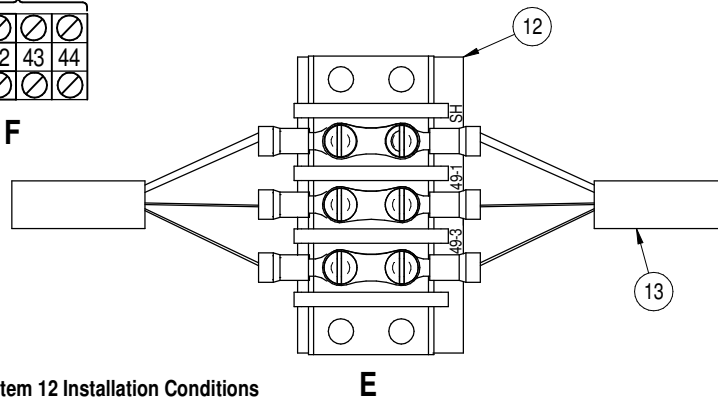
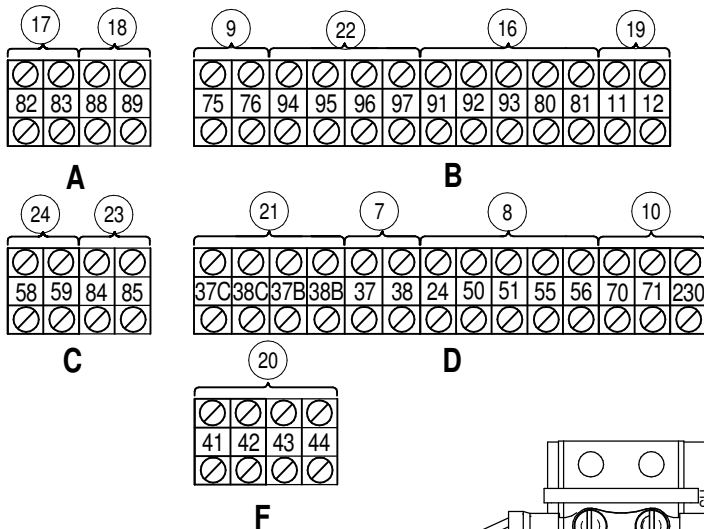

Item 12 Installation Conditions

1. Follow all local installation codes.
2. Do not run CAN cables in same conduit, raceway, or chase as high voltage wires (120-600V).
3. Separate high volt wires from CAN wires by 12 inches.



LIEBERT DSE

ELECTRICAL FIELD CONNECTION DESCRIPTIONS DA125, DA150 & DA165 DOWNFLOW MODELS

STANDARD ELECTRICAL CONNECTIONS

- 1) Primary high voltage entrance - 2.50" (64mm); 1.75" (44mm); 1.375" (35mm) diameter concentric knockouts located in bottom of box.
- 2) Primary low voltage entrance - Quantity (3) 1.375" (35mm) diameter knockouts located in bottom of unit.
- 3) Three phase electrical service - Terminals are on top of disconnect switch. Three phase service not by Liebert.
- 4) Earth ground - Terminal for field supplied earth grounding wire and component ground terminal strip. Earth grounding required for Liebert units.
- 5) Remote unit shutdown - Replace existing jumper between terminals 37 & 38 with field supplied normally closed switch having a minimum 75VA, 24VAC rating. Use field supplied Class 1 wiring.
- 6) Customer alarm inputs - Terminals for field supplied, normally open contacts, having a minimum 75VA, 24VAC rating, between terminals 24 & 50, 51, 55, 56. Use field supplied Class 1 wiring. Terminal availability varies by unit options.
- 7) Common alarm - On any alarm, normally open dry contact is closed across terminals 75 & 76 for remote indication. 1 AMP, 24VAC max load. Use Class 1 field supplied wiring.
- 8) Heat rejection interlock - On any call for compressor operation, normally open dry contact is closed across terminals 70 & 71 (Circuit 1), 230 (Circuit 2) to heat rejection equipment. 1 AMP, 24VAC max load. Use Class 1 field supplied wiring.
- 9) Unit factor installed disconnect switch, Fuse Block and Main Fuses – "Locking Type" consists of a non-automatic molded case switch operational from the outside of the unit. Access to the high voltage electrical panel compartment can be obtained only with the switch in the "off" position. Units with fused disconnects are provided with a defeater button that allows access to the electrical panel when power is on. The molded case switch disconnect models contain separate main fuses.

CANbus ELECTRICAL CONNECTIONS

- 10) CANbus Connector – Terminal block with terminals 49-1 (CAN-H) and 49-3 (CAN-L) + SH (shield connection). The terminals are used to connect the CANBus communication cable (provided by others) from the indoor unit to the Liebert MC Condenser –Optional Econophase unit.
- 11) CANbus Cable – CANbus cable provided by others to connect to the outdoor condenser and optional PRE unit. No special considerations are required when the total external cable connection between the indoor unit and outdoor unit(s) is less than 450FT (137M). For external cable connections greater than 450FT (137M), but less than 800FT (243M) a CANbus isolator is required (Contact Factory).
Cable must have the following specifications:
 - Braided shield or foil shield with drain wire
 - Shield must be wired to ground at indoor unit
 - 22-18AWG stranded tinned copper
 - Twisted pair (minimum 4 twists per foot)
 - Low Capacitance (15pF/FT or less)
 - Must be rated to meet local codes and conditions
 - EXAMPLES BELDEN 89207 (PLENUM RATED), OR ALPHA WIRE 6454 CATEGORY 5, 5E, OR HIGHER
- 12) Do not run in same conduit, raceway, or chase as high voltage wiring.
- 13) For CANbus network lengths greater than 450FT (137M) call Factory.



LIEBERT DSE

ELECTRICAL FIELD CONNECTION DESCRIPTIONS DA125, DA150 & DA165 DOWNFLOW MODELS

OPTIONAL ELECTRICAL CONNECTIONS

- 14) Smoke sensor alarm - Factory wired dry contacts from smoke sensor are 91-common, 92-NO, and 93-NC. Supervised contacts, 80 & 81, open on sensor trouble indication. This smoke sensor is not intended to function as, or replace, any room smoke detection system that may be required by local or national codes. 1 AMP, 24VAC max load. Use Class 1 field supplied wiring.
- 15) Reheat and humidifier lockout - Remote 24VAC required at terminals 82 & 83 for lockout of reheat and humidifier.
- 16) Condensate alarm (with condensate pump option) - On pump high water indication, normally open dry contact is closed across terminals 88 & 89 for remote indication. 1 AMP, 24VAC max load. Use Class 1 field supplied wiring.
- 17) Remote humidifier - On any call for humidification, normally open dry contact is closed across terminals 11 & 12 to signal field supplied remote humidifier. 1 AMP, 24VAC max load. Use Class 1 field supplied wiring.
- 18) Analog inputs- Terminals 41, 42, 43, 44 are user configurable for 0-10V, 0-5V, or 4-20MA.

OPTIONAL LOW VOLTAGE TERMINAL PACKAGE CONNECTIONS

- 19) Remote unit shutdown - Two additional contact pairs available for unit shutdown (labeled as 37B & 38B, 37C & 38C). Replace jumpers with field supplied normally closed switch having a minimum 75VA, 24VAC rating. Use field supplied Class 1 wiring.
- 20) Common alarm - On any alarm, two additional normally open dry contacts are closed across terminals 94 & 95 and 96 & 97 for remote indication. 1 AMP, 24VAC max load. Use Class 1 field supplied wiring.
- 21) Main fan auxiliary switch - On closure of main fan contactor, normally open dry contact is closed across terminals 84 & 85 for remote indication. 1 AMP, 24VAC max load. Use Class 1 field supplied wiring.
- 22) Liqui-Tect shutdown and dry contact - On LiquiTect activation, normally open dry contact is closed across terminals 58 & 59 for remote indication (LiquiTect sensor ordered separately). 1 AMP, 24VAC max load. Use Class 1 field supplied wiring.

OPTIONAL COMMUNICATION CONNECTIONS

- 23) Unit-to-Unit – Plug 64 is reserved for U2U communication.
- 24) Site and BMS – Plug 74 and terminal block 3 are reserved for Site and BMS connections. Plug 74 is an eight pin RJ45 for a Cat 5 cable. Terminal block 3 is a two position screw terminal block for use with twisted pair wires.

NOTE: Refer to specification sheet for total unit full load amps, wire size amps, and max overcurrent protective device size.

ELECTRICAL FIELD CONNECTIONS DA125, DA150 & DA165 DOWNFLOW MODELS

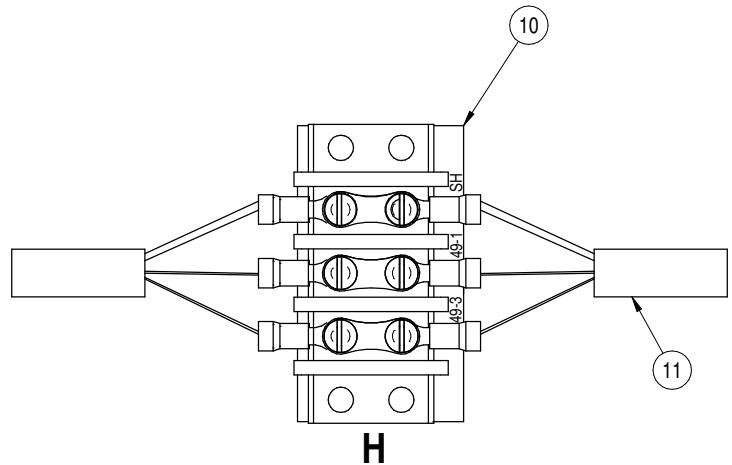
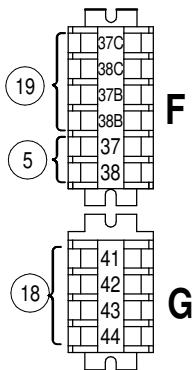
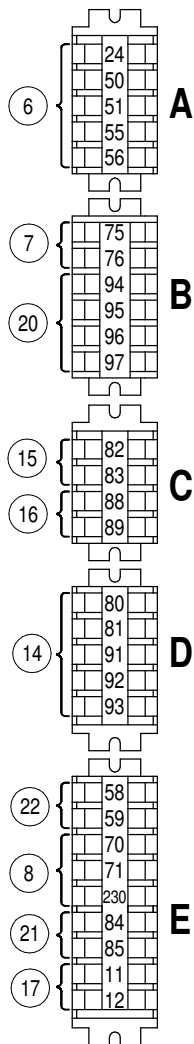
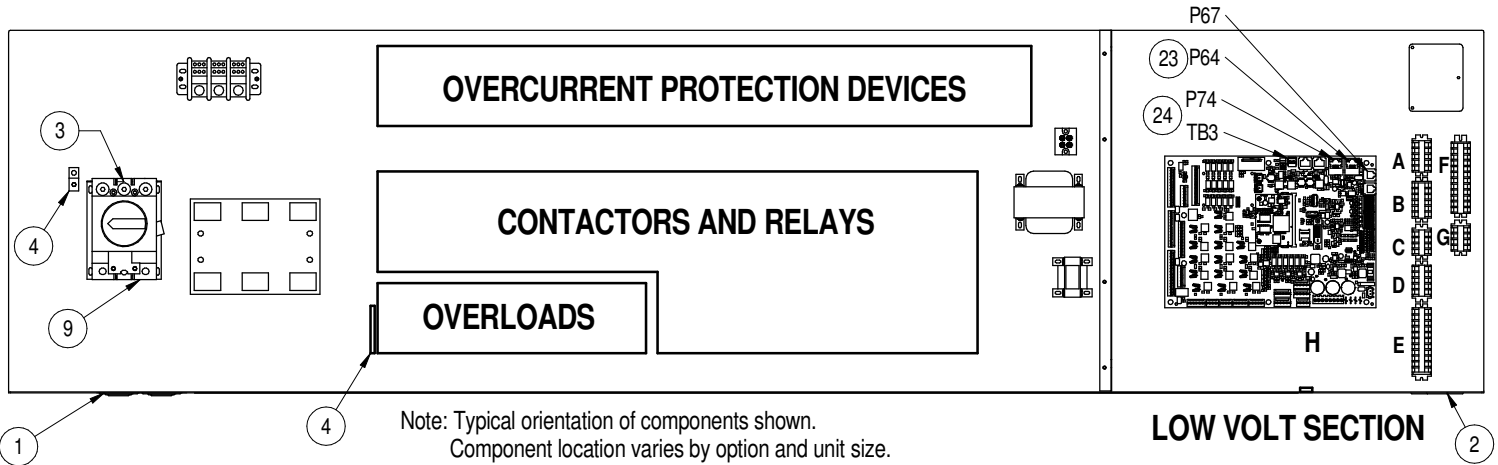

Item 11 Installation Conditions

1. Follow all local installation codes.
2. Do not run CAN cables in same conduit, raceway, or chase as high voltage wires (120-600V).
3. Separate high voltage wires from CAN wires by 12 inches.

ELECTRICAL FIELD CONNECTIONS DA125, DA150 & DA165 DOWNFLOW MODELS

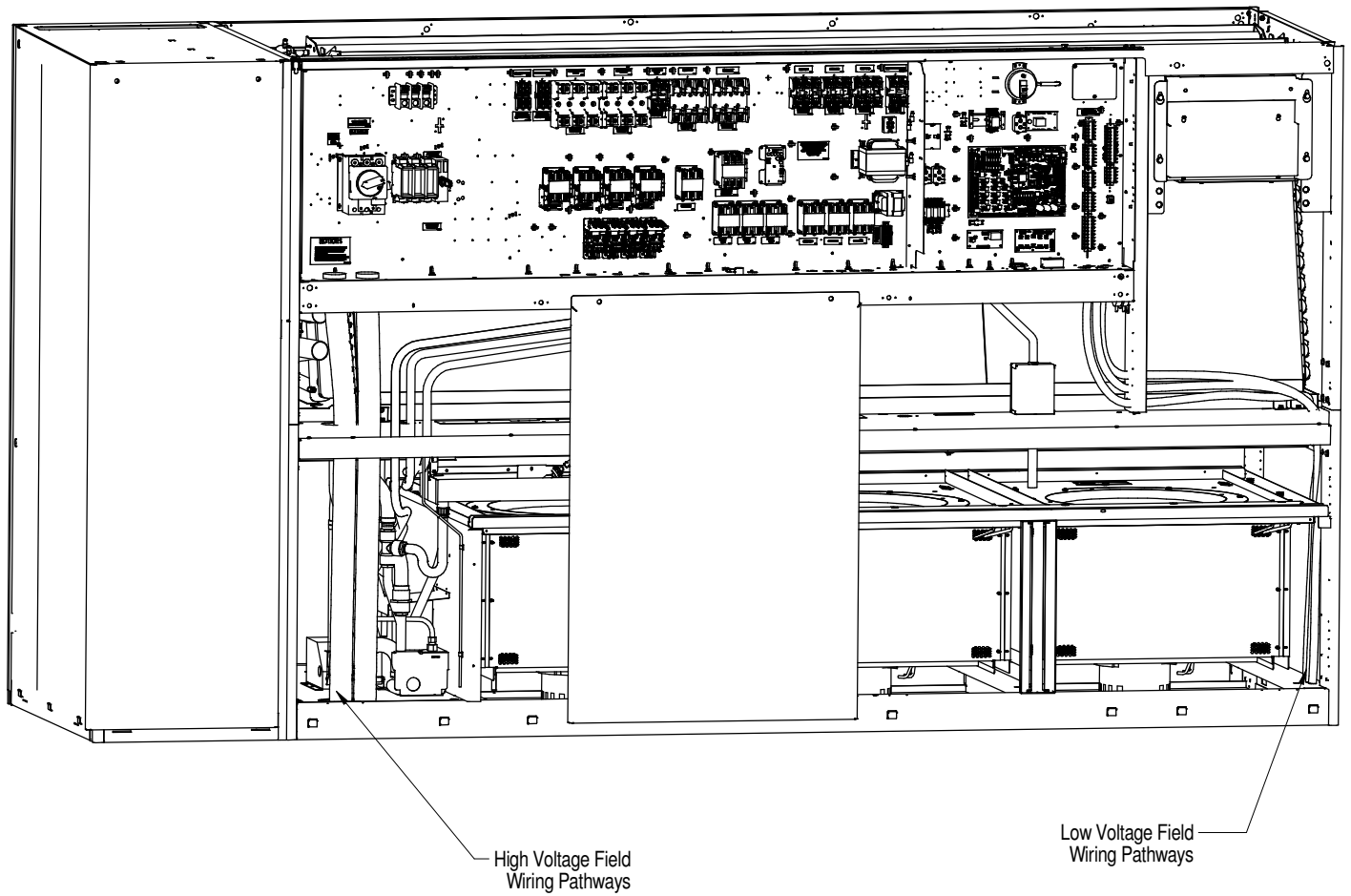

CANbus & INTERLOCK COMMUNICATIONS USING 1 LIEBERT MC CONDENSER & OPTIONAL ECONOPHASE UNIT

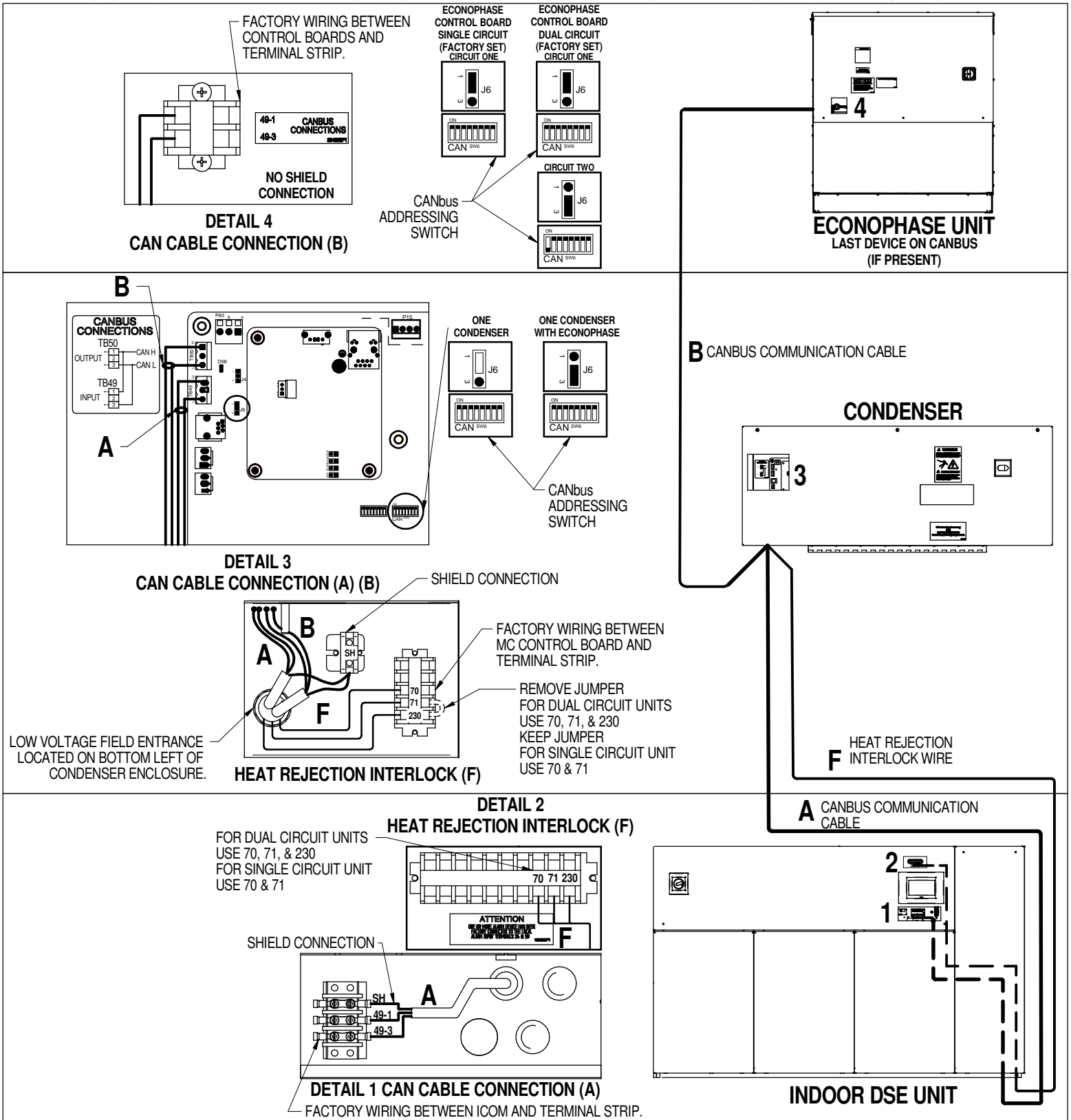



LIEBERT DSE

CANbus & INTERLOCK COMMUNICATIONS USING 1 LIEBERT MC CONDENSER & OPTIONAL ECONOPHASE UNIT

COMPONENT NOTES:

1. COMPONENT APPEARANCE, ORIENTATION, AND POSITION MAY VARY BETWEEN PRODUCT LINES. TERMINAL NAMES AND CALLOUTS REMAIN CONSTANT.
2. ALL CIRCUITS TO THESE CONNECTION POINTS ARE CLASS 2.

CAN & CABLE NOTES (A, B):

1. CABLE MUST HAVE THE FOLLOWING SPECIFICATIONS:
 - BRAIDED SHIELD OR FOIL SHIELD WITH DRAIN WIRE
 - SHIELD MUST BE WIRED TO GROUND AT INDOOR UNIT
 - 22-18AWG STRANDED TINNED COPPER
 - TWISTED PAIR (MINIMUM 4 TWISTS PER FOOT)
 - LOW CAPACITANCE (15pF/FT OR LESS)
 - MUST BE RATED TO MEET LOCAL CODES AND CONDITIONS.
 - EXAMPLES BELDEN 89207 (PLENUM RATED), OR ALPHA WIRE 6454 CATEGORY 5, 5E, OR HIGHER.
2. DO NOT RUN IN SAME CONDUIT, RACEWAY, OR CHASE AS HIGH VOLTAGE WIRING.
3. FOR CANBUS NETWORK LENGTHS GREATER THAN 450FT(137M), CONTACT LIEBERT FACTORY.

INTERLOCK WIRE NOTES (F):

1. FIELD SUPPLIED WIRE
 - 2 CONDUCTOR 18AWG OR GREATER FOR SINGLE REFRIGERANT CIRCUIT DSE UNITS.
 - 3 CONDUCTOR 18AWG OR GREATER FOR DUAL REFRIGERANT CIRCUIT DSE UNITS.
 - RATED 600V
2. RUN FIELD SUPPLIED WIRES BETWEEN THE INDOOR UNIT AND THE CONDENSER.

CANbus & INTERLOCK CONNECTIONS USING 2 LIEBERT MC CONDENSERS & OPTIONAL ECONOPHASE UNIT

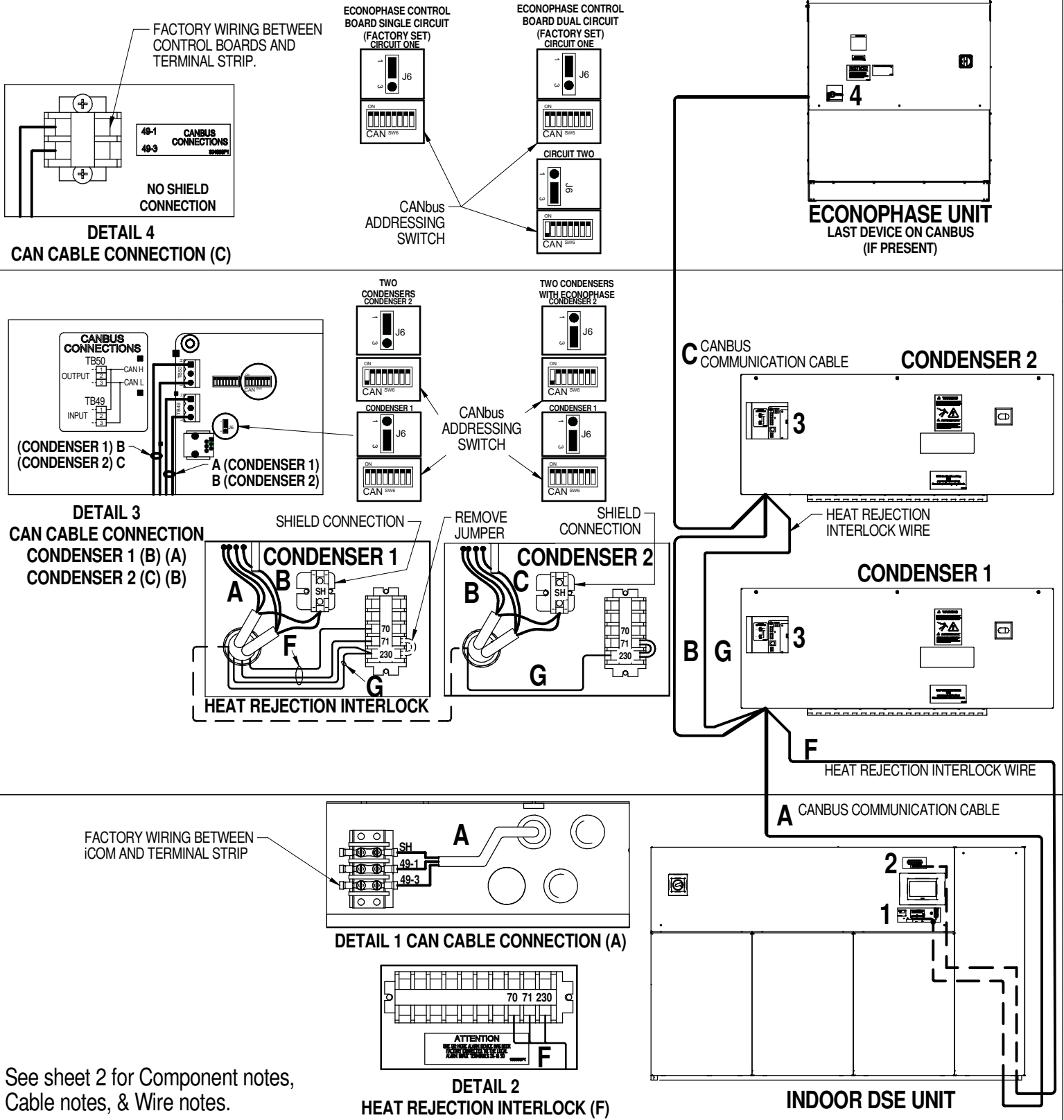

See sheet 2 for Component notes, Cable notes, & Wire notes.



LIEBERT DSE

CANbus & INTERLOCK CONNECTIONS

USING 2 LIEBERT MC CONDENSERS & OPTIONAL ECONOPHASE UNIT

COMPONENT NOTES:

1. COMPONENT APPEARANCE, ORIENTATION, AND POSITION MAY VARY BETWEEN PRODUCT LINES. TERMINAL NAMES AND CALLOUTS REMAIN CONSTANT.
2. ALL CIRCUITS TO THESE CONNECTION POINTS ARE CLASS 2.

CAN & CABLE NOTES (A, B, C):

1. CABLE MUST HAVE THE FOLLOWING SPECIFICATIONS:

- BRAIDED SHIELD OR FOIL SHIELD WITH DRAIN WIRE
 - SHIELD MUST BE WIRED TO GROUND AT INDOOR UNIT
 - 22-18AWG STRANDED TINNED COPPER
 - TWISTED PAIR (MINIMUM 4 TWISTS PER FOOT)
 - LOW CAPACITANCE (15pF/FT OR LESS)
 - MUST BE RATED TO MEET LOCAL CODES AND CONDITIONS.
 - EXAMPLES BELDEN 89207 (PLENUM RATED), OR ALPHA WIRE 6454 CATEGORY 5, 5E, OR HIGHER.
2. DO NOT RUN IN SAME CONDUIT, RACEWAY, OR CHASE AS HIGH VOLTAGE WIRING.
 3. FOR CANBUS NETWORK LENGTHS GREATER THAN 450FT (137M), CONTACT LIEBERT FACTORY.

INTERLOCK WIRE NOTES (F):

1. FIELD SUPPLIED WIRE
 - 3 CONDUCTOR 18AWG OR GREATER
 - RATED 600V
2. RUN FIELD SUPPLIED WIRES BETWEEN THE INDOOR UNIT AND CONDENSER 1.

INTERLOCK WIRE NOTES (G):

1. FIELD SUPPLIED WIRE
 - MINIMUM 1 CONDUCTOR 18AWG OR GREATER
 - RATED 600V
2. RUN FIELD SUPPLIED WIRES BETWEEN CONDENSER 1 AND CONDENSER 2.

LIEBERT HEAT REJECTION SKID

CANbus & INTERLOCK CONNECTIONS MCV + ECONOPHASE + BASE ASSEMBLY

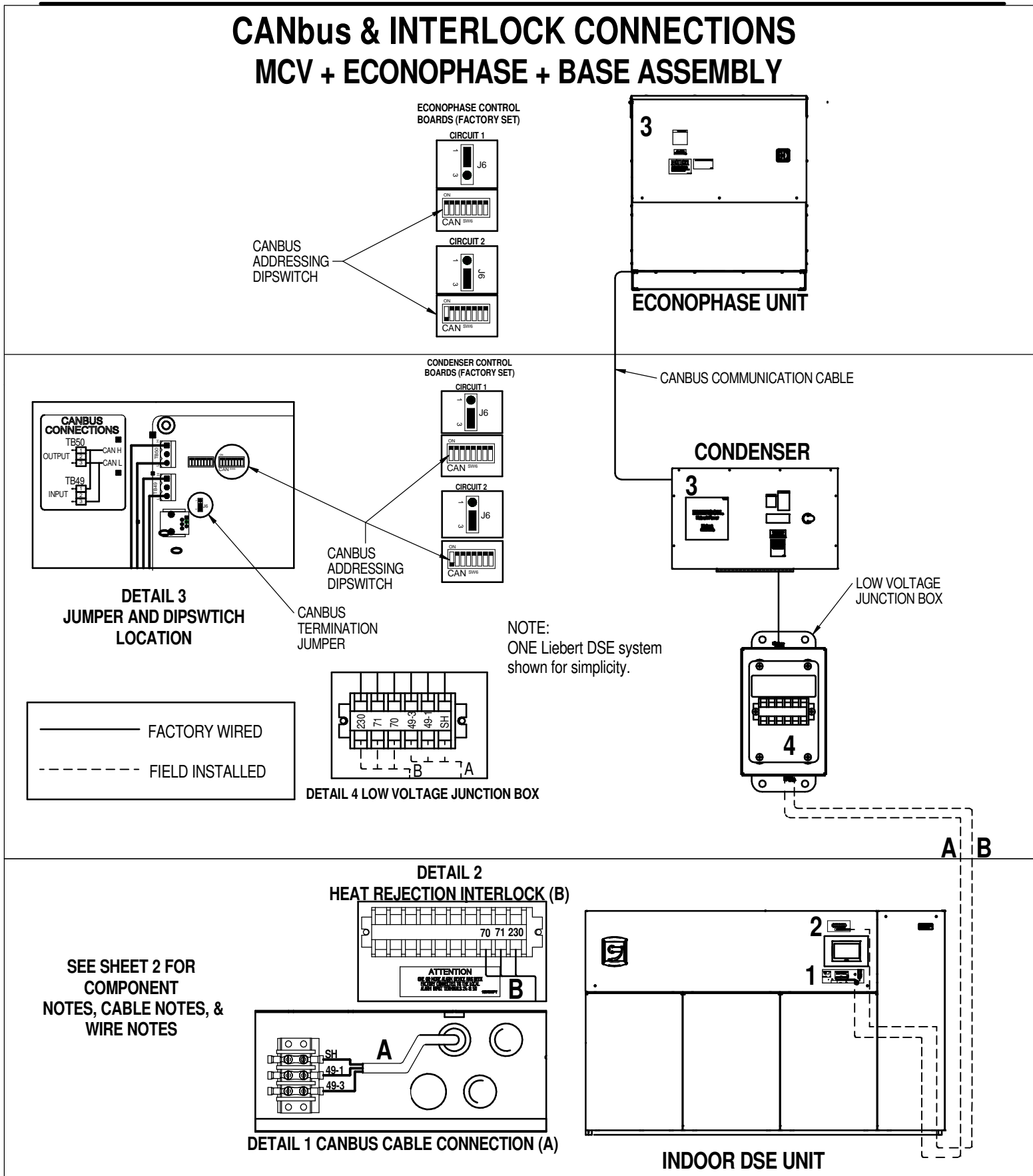

Form No.: DPN001040_REV14



LIEBERT HEAT REJECTION SKID

CANbus & INTERLOCK CONNECTIONS MCV + ECONOPHASE + BASE ASSEMBLY

COMPONENT NOTES:

1. COMPONENT APPEARANCE, ORIENTATION, AND POSITION MAY VARY BETWEEN PRODUCT LINES. TERMINAL NAMES REMAIN CONSTANT.
2. ALL CIRCUITS TO THESE CONNECTION POINTS REMAIN CONSTANT.

CAN & CABLE NOTES (A):

1. CABLE MUST HAVE THE FOLLOWING SPECIFICATIONS:
 - BRAIDED SHIELD OR FOIL SHIELD WITH DRAIN WIRE
 - SHIELD MUST BE WIRED TO GROUND AT INDOOR UNIT
 - 22-18AWG STRANDED TINNED COPPER
 - TWISTED PAIR (MINIMUM 4 TWISTS PER FOOT)
 - LOW CAPACITANCE (15pF/FT OR LESS)
 - MUST BE RATED TO MEET LOCAL CODES AND CONDITIONS.
 - EXAMPLES BELDEN 89207 (PLENUM RATED), OR ALPHA WIRE 6454 CATEGORY 5, 5E, OR HIGHER.
2. DO NOT RUN IN SAME CONDUIT, RACEWAY, OR CHASE AS HIGH VOLTAGE WIRING.
3. FOR CANBUS NETWORK LENGTHS GREATER THAN 450FT(137M), CONTACT LIEBERT FACTORY.

INTERLOCK WIRE NOTES (B):

1. FIELD SUPPLIED WIRE
 - 3 CONDUCTOR 18AWG OR GREATER
 - RATED 600V
2. RUN FIELD SUPPLIED WIRES BETWEEN THE INDOOR UNIT AND THE LOW VOLTAGE JUNCTION BOX.



LIEBERT DS, DSE, CW, PDX & PCW

UNIT TO UNIT NETWORK CONNECTIONS

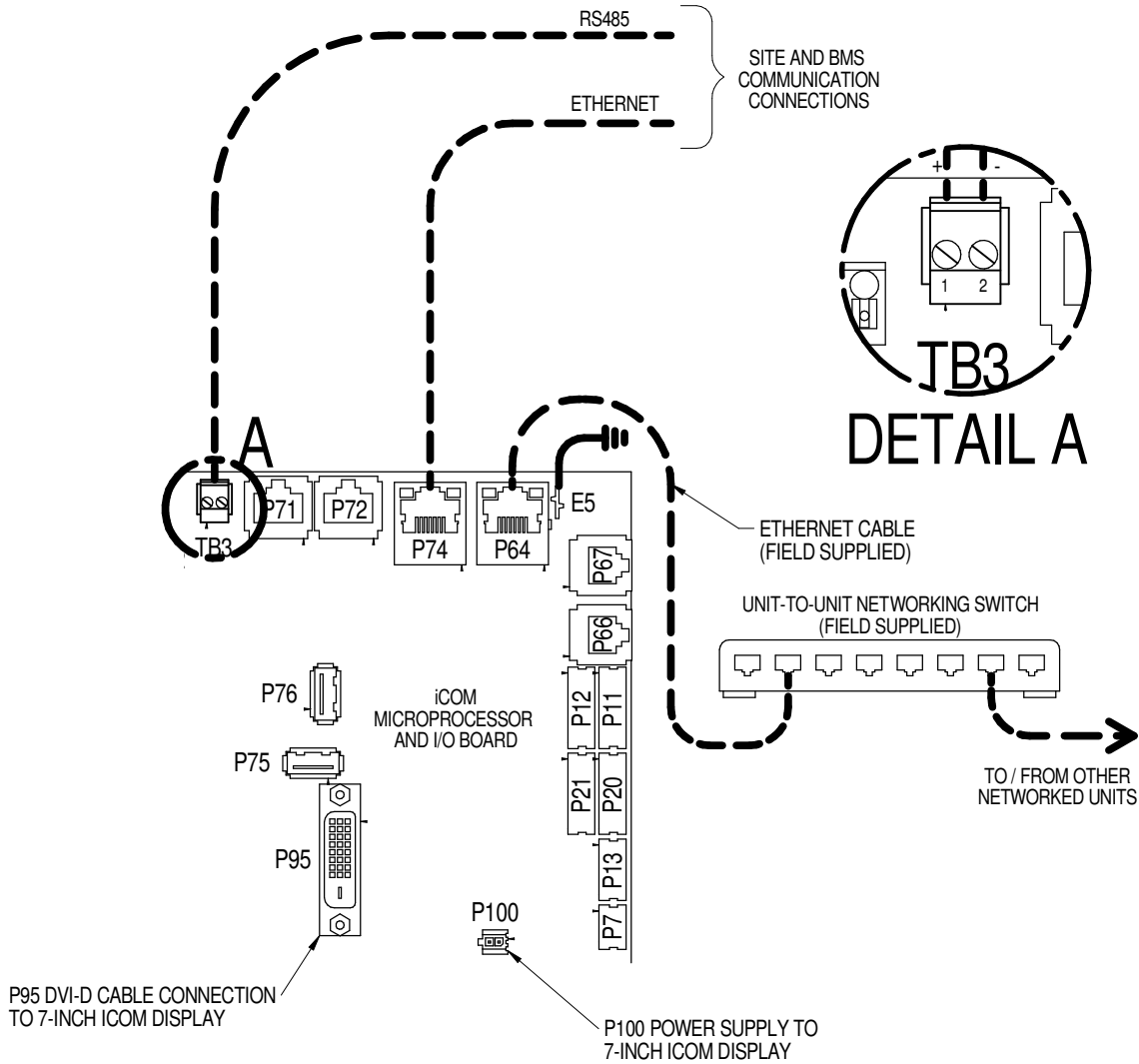

UNIT TO UNIT NETWORK CONNECTIONS

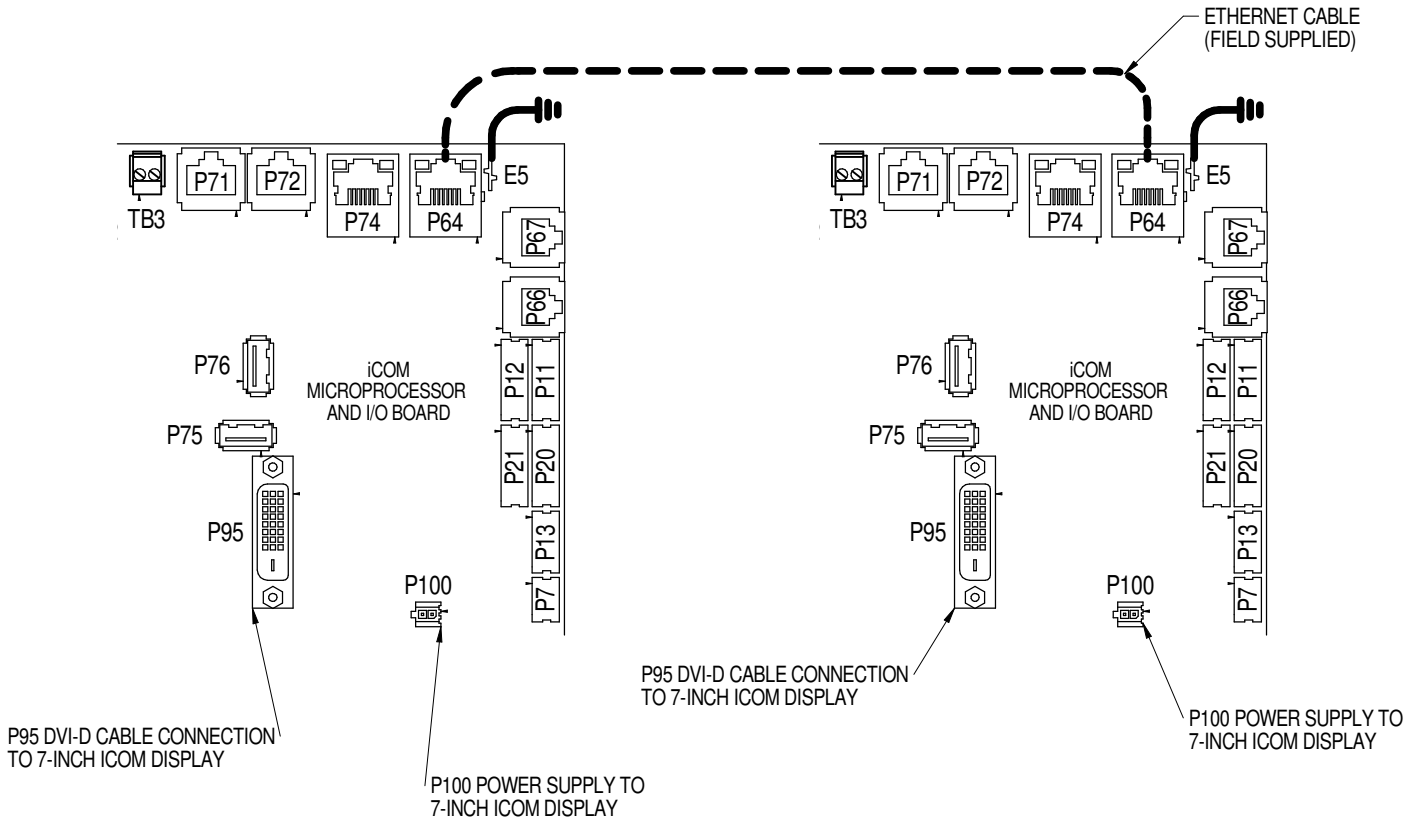

NOTE* For dual-unit network configurations only

DISASSEMBLY DIMENSIONAL DATA DOWNFLOW DA050

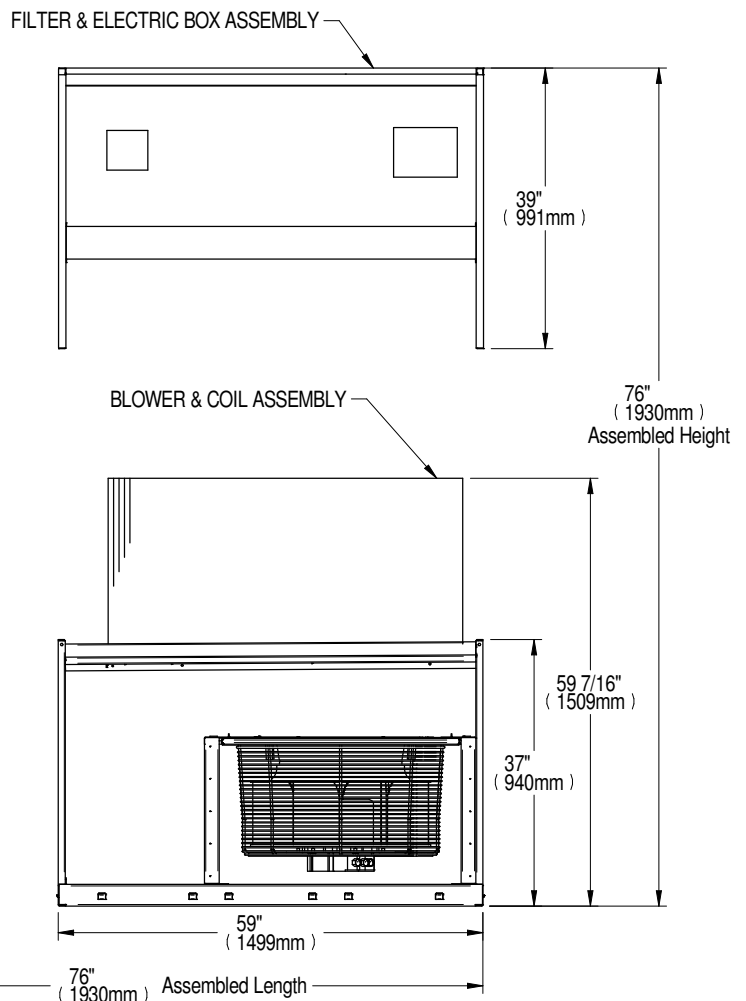
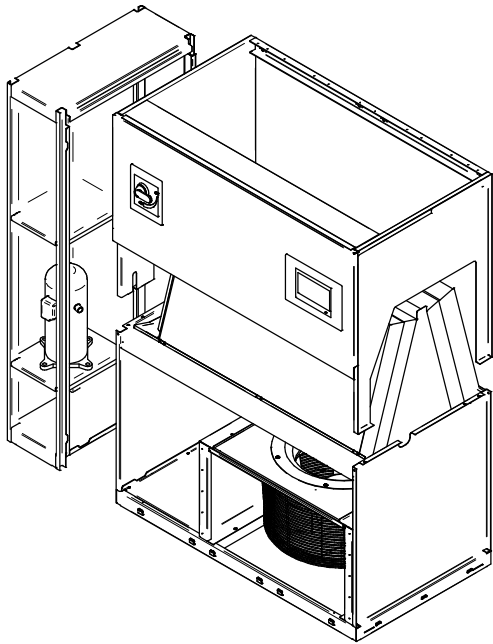

APPROXIMATE DRY WEIGHT lb (kg) (Includes Panels)	
COMPRESSOR ASSEMBLY	460 (209)
FILTER & ELECTRIC BOX ASSEMBLY	210 (96)
BLOWER & COIL ASSEMBLY	920 (417)

Notes:

1. Drawing views are simplified with panels removed to show overall dimensions.
2. See disassembly and handling instructions in installation manual.

DISASSEMBLY DIMENSIONAL DATA DOWNFLOW DA080-DA085

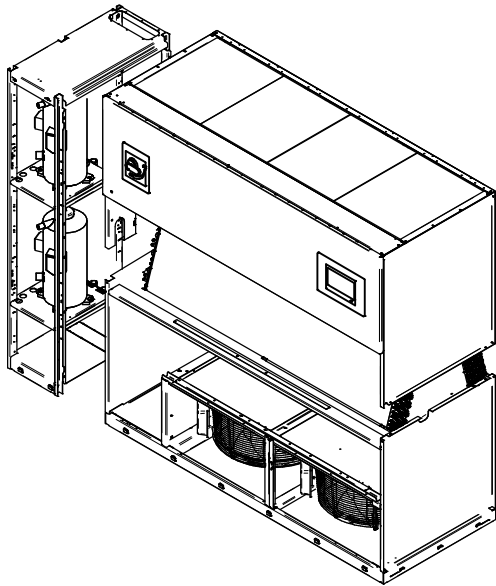

FILTER & ELECTRIC BOX ASSEMBLY

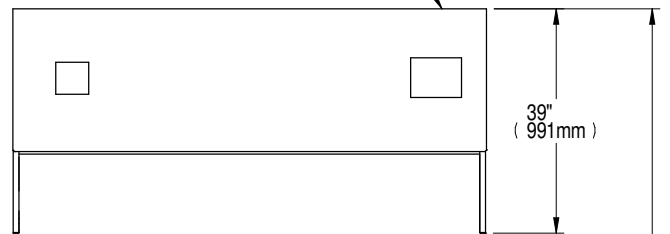

COMPRESSOR ASSEMBLY

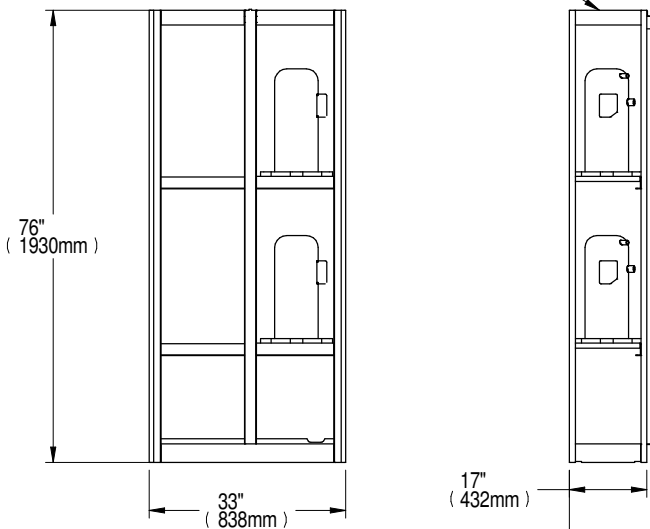

BLOWER & COIL ASSEMBLY

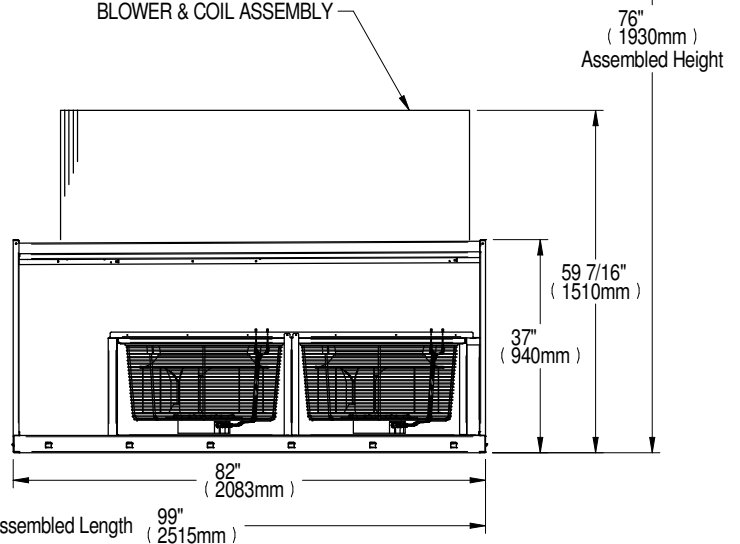

APPROXIMATE DRY WEIGHT lb (kg) (Includes Panels)	
COMPRESSOR ASSEMBLY	590 (269) ³
FILTER & ELECTRIC BOX ASSEMBLY	250 (114)
BLOWER & COIL ASSEMBLY	1410 (641)

Notes:

1. Drawing views are simplified with panels removed to show over all dimensions.
2. See disassembly and handling instructions in installation manual.

³ Add 120lbs. (54kg) for 575V Transformer.

DISASSEMBLY DIMENSIONAL DATA DOWNFLOW AIR COOLED DA125, DA150 & DA165

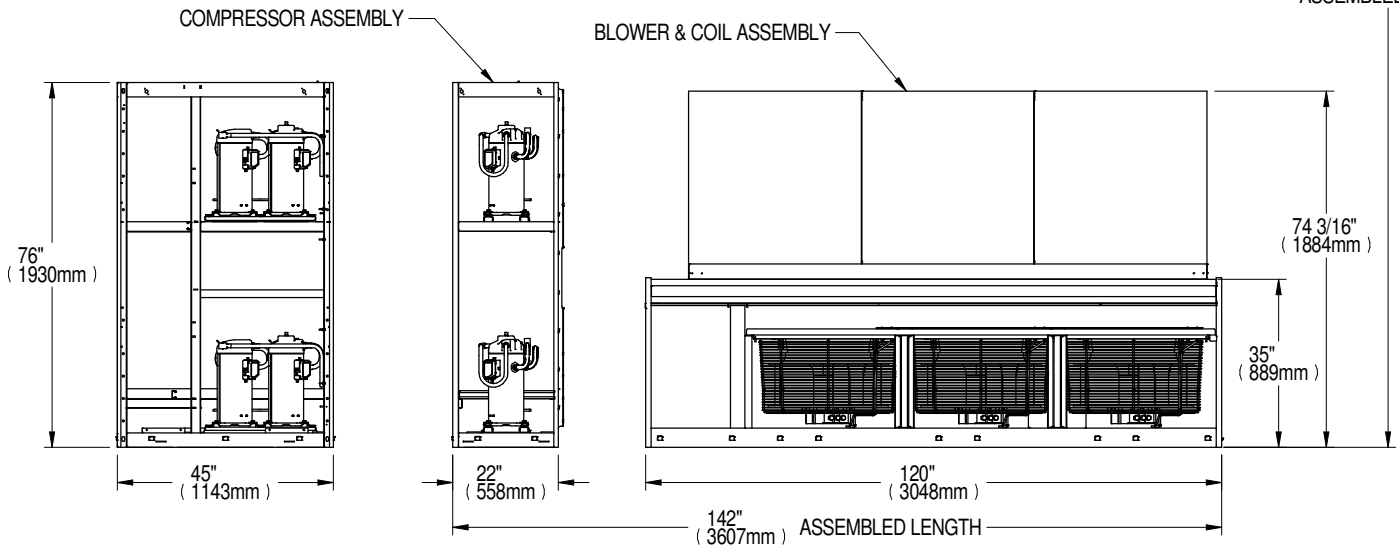
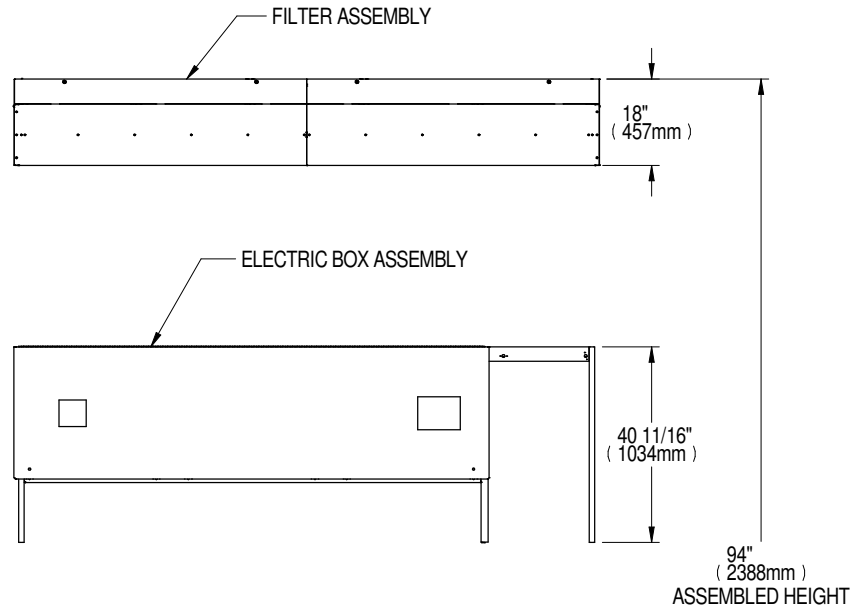
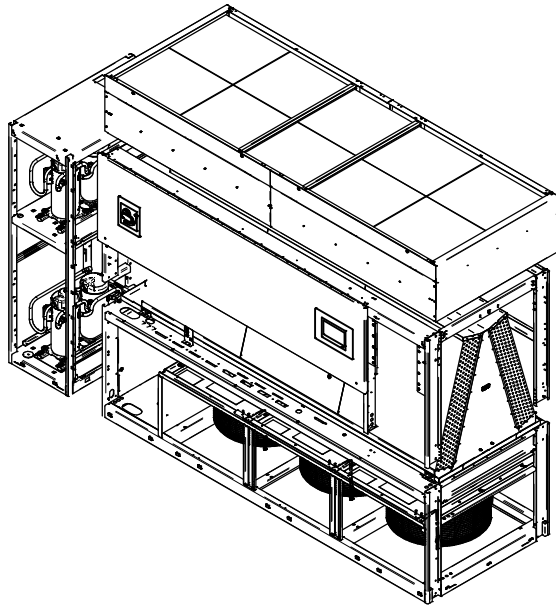

DRY WEIGHT lb(kg) APPROXIMATE (Includes Panels)		
	DA125	DA150/DA165
COMPRESSOR ASSEMBLY	630 (286)	739 (335)
ELECTRIC BOX ASSEMBLY	417 (189)	417 (189)
BLOWER & COIL ASSEMBLY	2218 (1006)	2218 (1006)
FILTER ASSEMBLY	200 (91)	200 (91)

NOTE: Drawing views are simplified with panels removed to show over all dimensions.
See disassembly and handling instructions in installation manual.

DISASSEMBLY DIMENSIONAL DATA UPFLOW DA080-DA085

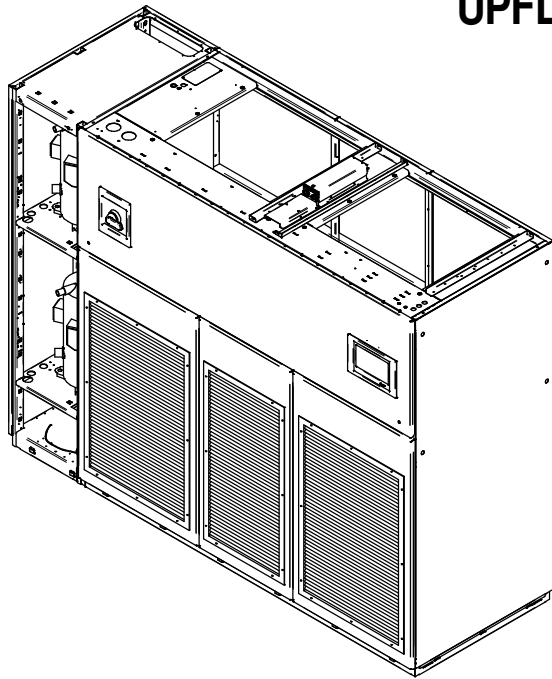

COMPRESSOR ASSEMBLY

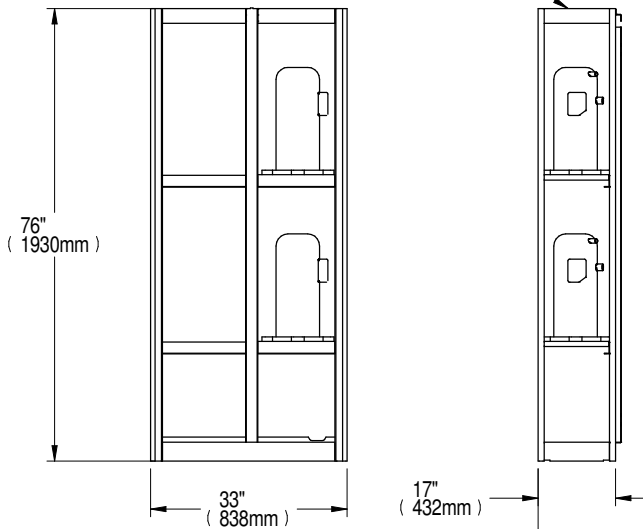

ELECTRIC BOX ASSEMBLY

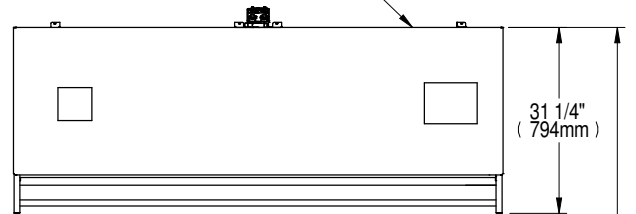

FILTER & COIL ASSEMBLY

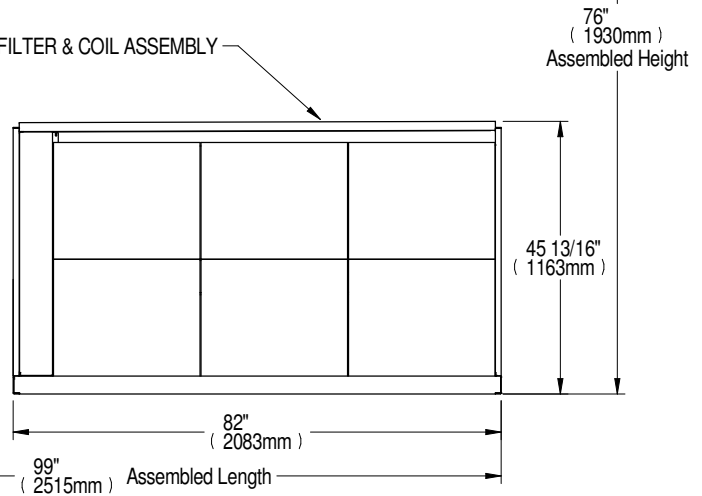

APPROXIMATE DRY WEIGHT lb (kg) (Includes Panels) ³	
COMPRESSOR ASSEMBLY	590 (269) ⁴
ELECTRIC BOX ASSEMBLY	600 (272)
FILTER & COIL ASSEMBLY	960 (436)

Notes:

1. Drawing views are simplified with panels removed to show overall dimensions.
2. See disassembly and handling instructions in installation manual.

³ Fan weight not included in this unit weight. Fan is installed in plenum.

⁴ Add 120lbs. (54kg) for 575V Transformer.





Vertiv.com | Vertiv Headquarters, 1050 Dearborn Drive, Columbus, OH, 43085, USA

© 2019 Vertiv Group Corp. All rights reserved. Vertiv and the Vertiv logo are trademarks or registered trademarks of Vertiv Group Corp. All other names and logos referred to are trade names, trademarks or registered trademarks of their respective owners. While every precaution has been taken to ensure accuracy and completeness herein, Vertiv Group Corp. assumes no responsibility, and disclaims all liability, for damages resulting from use of this information or for any errors or omissions. Specifications are subject to change without notice.

SL-18933_REV3/590-1423-501D