

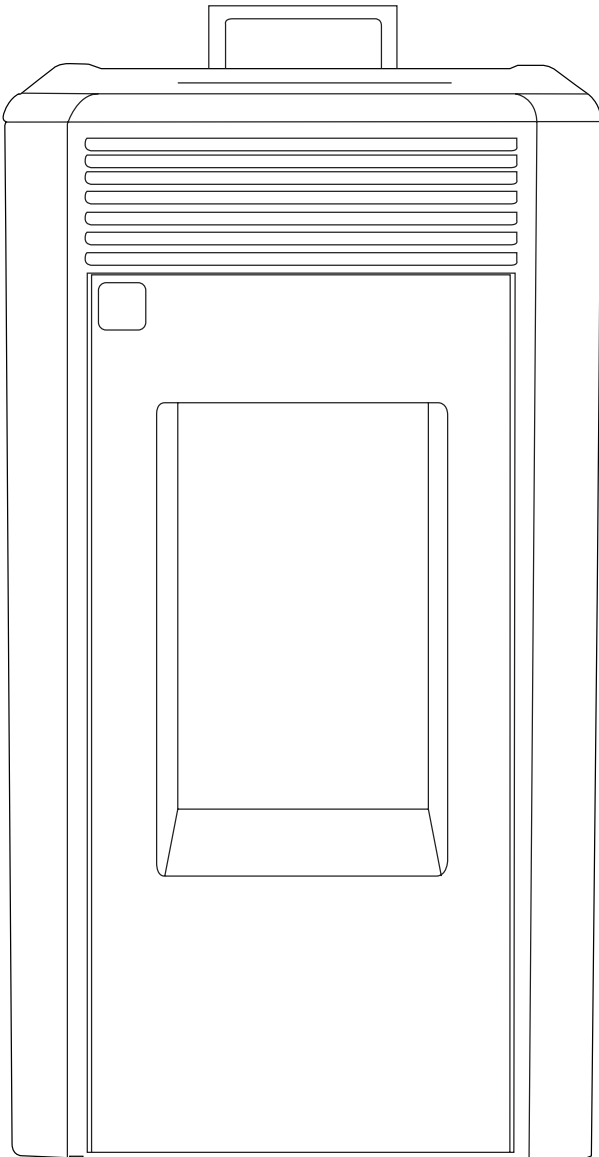

# Scandia

# PELLET FIRE OWNERS MANUAL



## SERIES 1

Pellet Fire - Verdant LE

---

### Scandia Group Pty Ltd

Head Office  
58 Access Way  
Carrum Downs VIC 3201  
Australia

**AUS 1300 HEATER (432 837)**  
**NZ +61 3 8579 5900**  
**info@scandiastoves.com.au**  
**www.scandiastoves.com.au**

SC.VER Version 1.3 10/5/19

Contents of manual may be updated without notice.  
For the latest version of this manual please refer to our website: [www.scandiastoves.com.au](http://www.scandiastoves.com.au)



# SCANDIA PELLET FIRE

Model Name	Model Number
Verdant LE	SCPH02

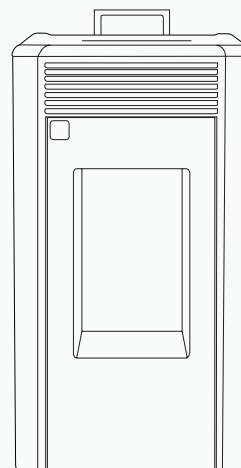

## CONTENTS

Safety precautions	2
Product dimensions	3
Fuel requirements	4
Seismic restraint of the pellet fire	5
Installation guide	6
Operating instructions	9
Maintenance	14
Trouble shooting	17
Wiring diagram	19
Exploded diagram	20
Parts listing	21
Warranty	22

## INTRODUCTION

Congratulations on purchasing a genuine Scandia pellet fire. When cared for properly, this high quality, finely crafted pellet fire will offer many years of reliable performance. This instruction manual has been developed to ensure optimum performance from your Scandia pellet fire. It is very important that you thoroughly read and understand all instructions before using your new stove.

## COUNCIL REQUIREMENTS

### Check Local Council Requirements Eg. permits

When installing, operating and maintaining your pellet fire, follow the guidelines presented in these instructions, and make them available to anyone using or servicing the pellet fire. *Your city, town, state or territory may require a building permit to install a pellet fire.* Always consult your local building inspector or local council to determine what regulations apply in your area.



### WARNING

Your pellet fire must be installed by a qualified person whose work conforms with local council regulations, Australian/New Zealand standards and manufacturers recommendations. Failure to do so will void your warranty and could possibly void any home insurance.

# SAFETY PRECAUTIONS

When properly maintained and operated your pellet fire should give you many years of service, however there are important safety aspects of these products that you need to be aware of when operating a pellet fire. Installation and repair should only be performed by a professional service technician. Do not attempt to service the appliance yourself.

1. Do not place articles on or against this appliance.
2. Do not use or store flammable material near the appliance.
3. Do not touch working stove or there will be a high risk of skin burns.
4. Do not spray aerosols in the vicinity of this appliance while in operation.
5. Do not modify this appliance.
6. Select and use pellets which are dry and low ash content. Unqualified fuel will adversely affect operation and performance of stove and void warranty. We have listed wood pellet standards on pages 4 -5 'Fuel requirements'. Pellets needs to meet or exceed these standards. Ask your dealer for recommended pellet type.
7. Do not connect pellet fire to any air distribution duct or system.
8. Do not burn garbage or flammable fluids such as gasoline, naphtha or engine oil.
9. Keep the thermostat sensor at rear of stove far from flue pipe. This sensor is to detect room temperature and should not be influenced by any heat source.
10. Do not operate appliance if front glass removed, cracked or broken. Glass replacement should be done by a qualified service technician.
11. Glass and other surfaces are hot during operation as well as during the cooling down period. Precaution should be taken, and young children/pets must be supervised at all times.
12. A slight smell may be apparent for the first few hours of use. This is due to the heat resistant paint curing. Open windows in the room for the first lighting of the fire. In some instances, a slight discolouration may occur inside the firebox, this is a normal condition and is not covered by warranty.
13. The stove will power off and the fire will extinguish until the stove reduces to the safety temperature of 700°C.
14. The stove will shut down when thermodisc for the hopper falls below 90°C.
15. Flue pipes should be sealed with a high temperature silicon to prevent unwanted smoke/fumes leaking into the room.



## WOOD CANNOT BE USED IN PELLETT FIRE

FUEL: This pellet fire is designed and approved to burn wood pellets with no more than 3% ash content. High ash content will adversely affect operation and performance of stove and may void the warranty. Please contact your dealer for more detailed fuel recommendations.

# PRODUCT DIMENSIONS (MM)

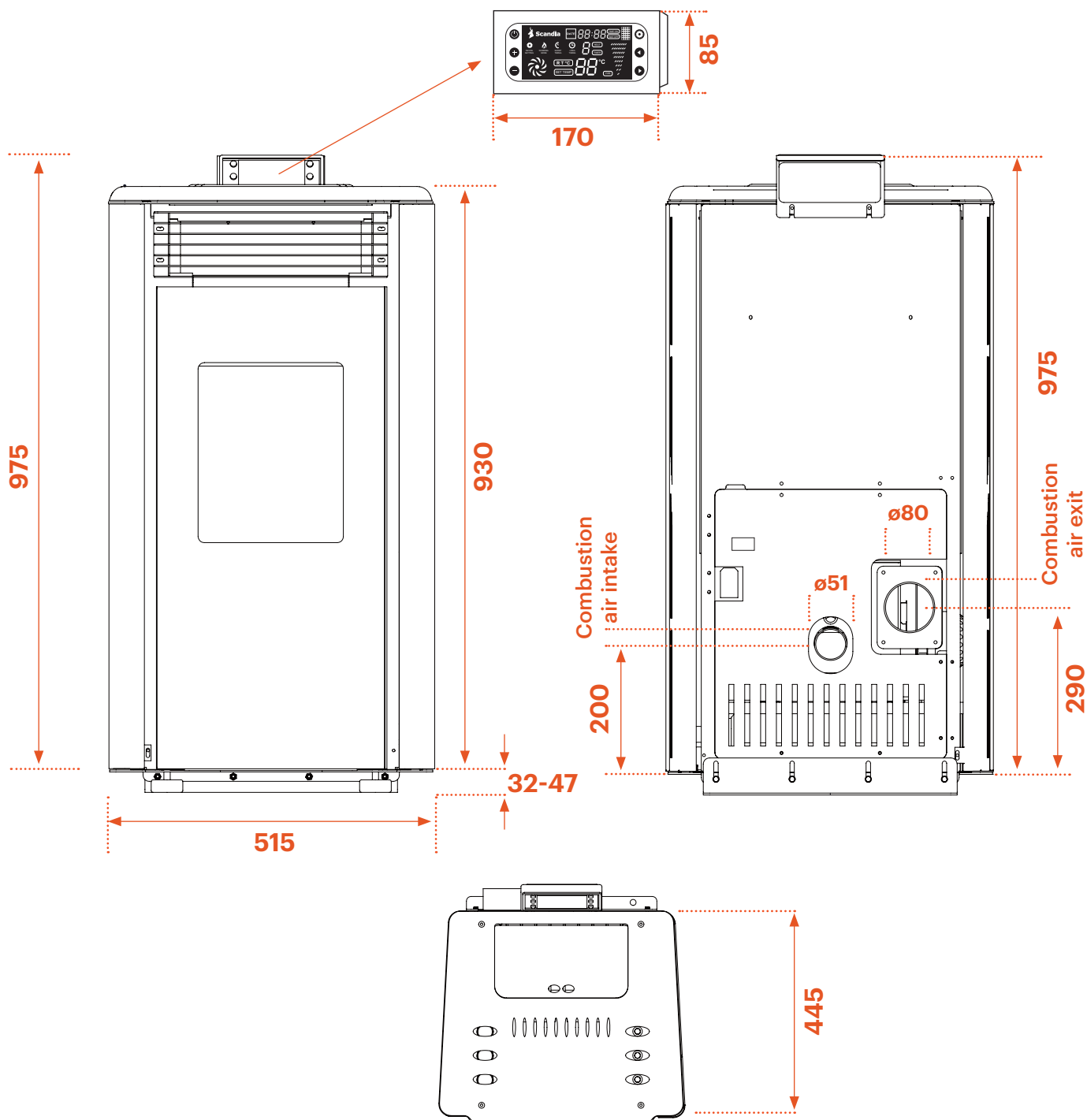

## IMPORTANT

This pellet fire should only be installed by an authorised technician in accordance with:

- Manufacturers installation instruction
- Local electrical regulations building codes

# FUEL REQUIREMENTS

Your pellet fire has been designed to burn wood pellets only.

Do not use any other type of fuel as this will void any warranties stated in this manual.

Quality pellet fuel is a natural product manufactured without any binders or additives. The pellets are formed under pressure from waste sawdust. There are many variables that will affect the composition of the pellet fuel and the specifications.

The performance of your pellet fire is greatly affected by the type and quality of wood pellets being burned.

As the heat output of various quality wood pellets differs, so will the performance and heat output of the pellet fire.

**We recommend the use of pellets that meet or exceed these standards.**

**Please use a recommended pellet type.**

Moisture content (as fired basis)	≤12 %
Ash content (as fired basis)	≤1.0%
Net (lower) calorific value (as fired basis)	16900KJ/KG to 20000 KJ/KG
Diameter	6mm
Length	≤40mm

## ASH

The ash content of the wood pellets and stove operation will determine the frequency needed for cleaning. When using high ash content fuels, this may result in frequently having to clean the stove. A low ash fuel may allow longer intervals between cleaning.

## CLINKERING

Clinkers are silica (sand) or other impurities in the fuel which form a hard mass during burning. The hard mass blocks air in the burn pot and affects the performance of the stove. All fuel will result in clinkers, even approved types. Check burn-pot every day to ensure that holes are not blocked by clinkers. If blocked, remove the pot (when the unit is cold) and clean/scrape the clinkers with a cleaning tool.

For more details, please refer to the Routine Cleaning and Maintenance section on Pages 14 -15.

## PELLET FEED RATES

Due to different densities and sizes of pellets, the feed rate varies. This may require an adjustment to combustion fan for burning speed and feeding time. Scandia cannot control the quality of pellets you use, therefore will not be held responsible for problems caused by bad quality wood pellets.

Take care of pellets by keeping them dry and intact, otherwise stove efficiency will be affected and dust will collect on the glass door. Wood pellets are made from compressed sawdust and scrap wood. Pellets made from hardwoods contain higher ash than those made from softwoods. Mineral and sand is more easily turned into clinker under extreme burning temperature. Try to burn various brands of pellets until you find a good one (producing minimum ash and clinkers). If using a pellet with excessive moisture content, the feeding auger may jam.



### WARNING

Only use dry wood pellets that are free of dirt and impurities (such as a high salt content). Dirty fuel will adversely affect the operation and performance of the stove and may void product warranty.

# SEISMIC RESTRAINT OF THE PELLET FIRE

## NEW ZEALAND REQUIREMENT

In order to comply with standard AS/NZS2918:2001, it is required that the wood fire and floor protector be secured to prevent shifting in the event of an earthquake. Anchor the appliance to the floor through the holes in the base (foot) of the appliance.

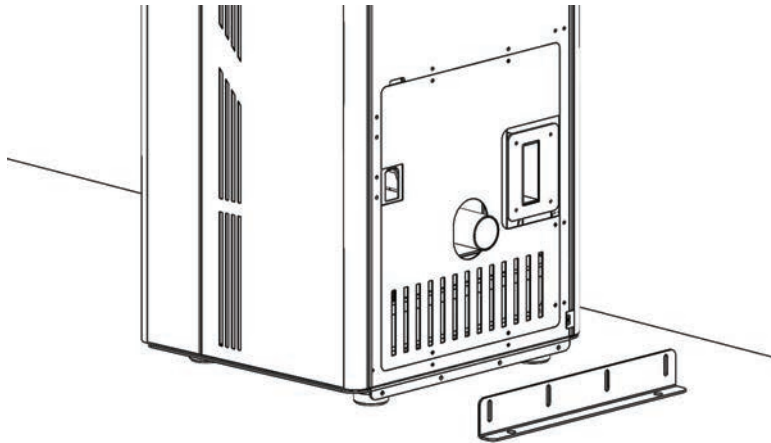

### STEP ONE

Fasten the floor bracket to the bottom rear of the pellet fire using the bolts provided. Adjust the floor bracket to the desired height before tightening the bolts with a spanner or socket wrench.

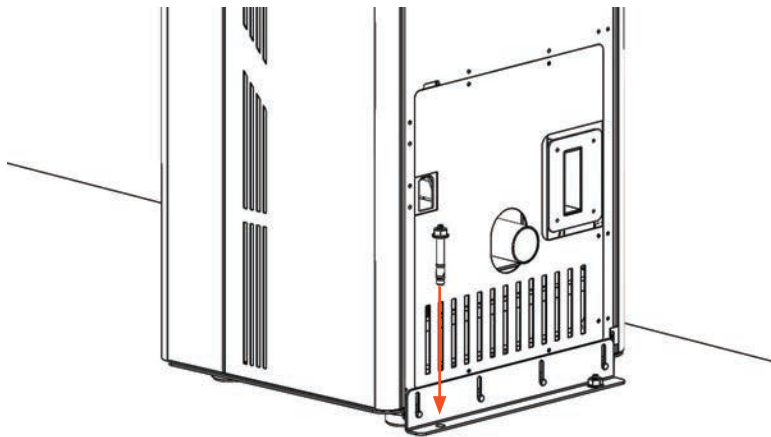

### STEP TWO

Once the floor bracket has been tightly secured to the heater, consider the exact location of your pellet fire. Ensure that the location chosen is compliant with the clearances stated in this manual. Your pellet fire should also be installed on a non-combustible surface. Using the appropriate sleeve anchor/bolt, secure your heater to the ground.

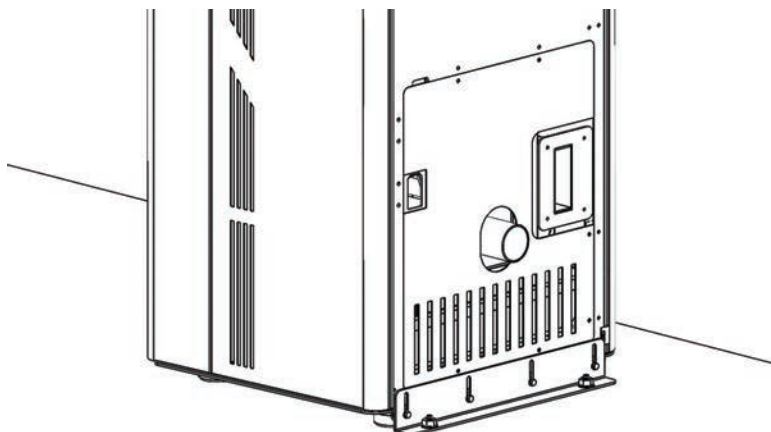

### STEP THREE

Ensure that all of the bolts have been tightened and your pellet fire is secure.

# INSTALLATION GUIDE

1. Set the stove in a place that complies with the heating range.
2. If installing this unit on a combustible floor (eg. linoleum or hardwood floor), a non-combustible hearth pad with a minimum 730 mm deep x 635 mm wide x 9 mm thick floor protector should be used under and in front of the appliance. The floor protector should extend 300 mm in front of the appliance door and be placed centrally in the 635 mm width.
3. Clearance distance from a wall or ceiling must be 50 mm or more.
4. The unit must be grounded. The grounded electrical cord should be connected to a standard electrical outlet, 230V, 50Hz (4.5 Amps). Ensure that electrical cord is clear of the appliance and away from hot surfaces and sharp edges. If power cord is compromised, a replacement power cord must be purchased from the manufacturer or qualified dealer.

## CLEARANCES TO COMBUSTIBLES

It is extremely important that you respect required installation distances and that you respect local installation regulations. The manufacturer is not responsible for the product if it is not installed following these instructions.

A combustible surface is anything that can burn i.e. plaster, wall paper, wood, fabrics etc.

These surfaces are not limited to those that are visible and also include materials that are behind non-combustible materials.

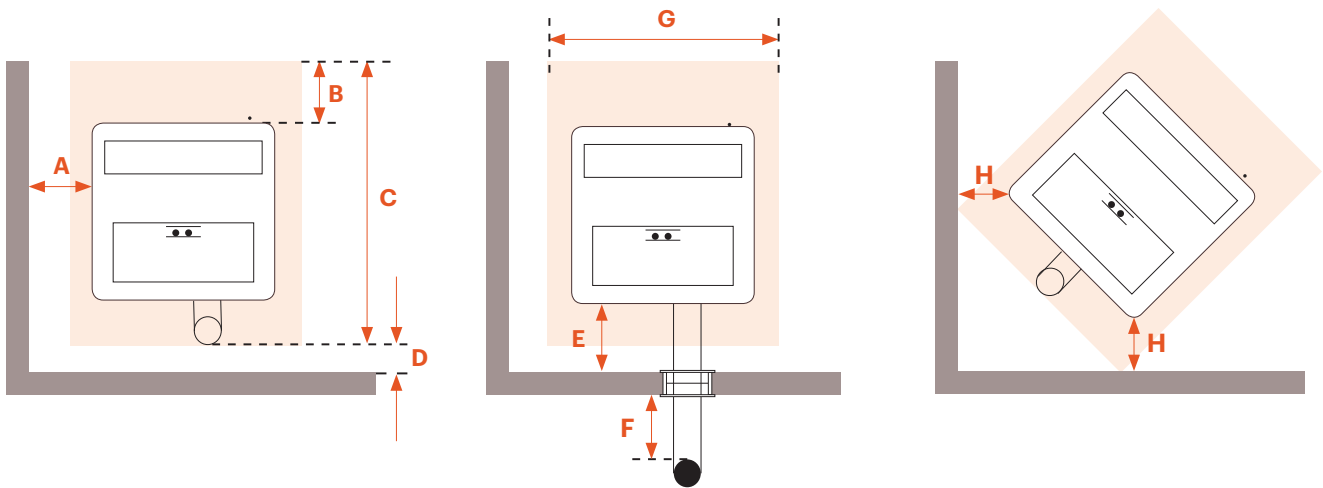

### Minimum clearances for a combustible surface

A	Side of the heater	100mm	E	Back of heater to wall (External installation)	50mm
B	Front of heater to hearth front	300mm	F	External flue to wall	50mm
C	Minimum hearth depth	730mm	G	Hearth width	635mm
D	Back of flue to wall	50mm	H	Rear corner	25mm



Illustrations and photos reflect typical installations and are for design purposes only. Illustrations/diagrams are not drawn to scale. Actual product may vary from pictures in manual.



# INSTALLATION GUIDE.... continued

## STANDARD INSTALLATION:

STANDARD FLUE KIT		
A	Cowl	x 1
B	Ø 80mm Stainless Steel Active Flue 915mm Long	x 1
C	Ø 150mm Galvanised Plain Casing 915mm Long	x 1
D	Scandia roof flashing (Usually supplied by installer)	
E	Ø 150mm Galvanised Crimped Casing 915mm Long	x 1
F	50 x 50 Angles 915mm Long	x 2
G	Ceiling Ring	x 1
H	Ø 80mm Painted Stainless Steel Active Flue 915mm Long	x 3
I	Tee Piece	x 1

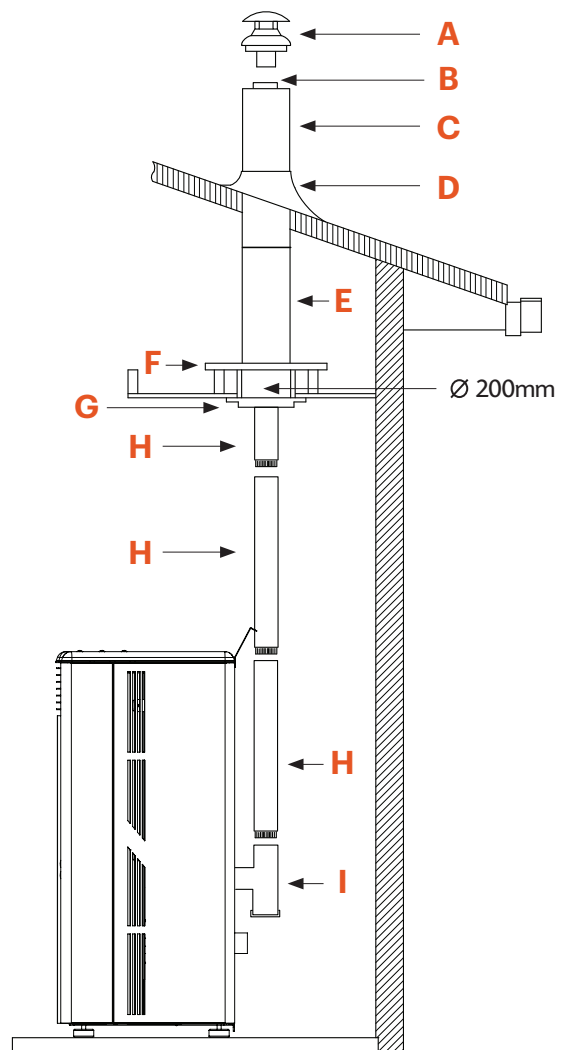

1. Do not place vent pipe exhaust in any enclosed or semi-enclosed areas such as a carport, garage, attic, crawlspace, narrow walkway, closely fenced area, under a sun deck or porch, or any location that would gather smoke.
2. The surface of vent pipe can reach high temperatures. Do not touch. If necessary, a non-combustible glove or guard can be used.
4. Locate vent termination at least 600mm away from combustible material such as shrubs, plants, grass, fences, roof overhangs, and adjacent buildings.

The stoves combustion blower pressurises and pushes flue gases out of the pellet pipe, therefore it is important that all pipe joints should be locked together. If the pipe joints do not have a locking system it is recommended that they are screwed with three screws and sealed with high temperature silicone. The pipe should be siliconed and fastened with three screws to the stoves flue collar.

# INSTALLATION GUIDE.... continued

## THROUGH WALL INSTALLATION:

### STANDARD FLUE KIT

A	Cowl	x 1
B	Ø 80mm Stainless Steel Active Flue 915mm Long	x 1
C	Ø 150mm Galvanised Plain Casing 915mm Long	x 1
D	Scandia roof flashing (Usually supplied by installer)	
E	Ø 150mm Galvanised Crimped Casing 915mm Long	x 1
F	50 x 50 Angles 915mm Long	x 2
G	Ceiling Ring	x 1
H	Ø 80mm Painted Stainless Steel Active Flue 915mm Long	x 3
I	Tee Piece	x 1

### THROUGH WALL FLUE KIT

J	Wall penetration collar (Ø 80mm Stainless Steel Active Flue 600mm Long)	x 2
K	(cut to length)	x 1

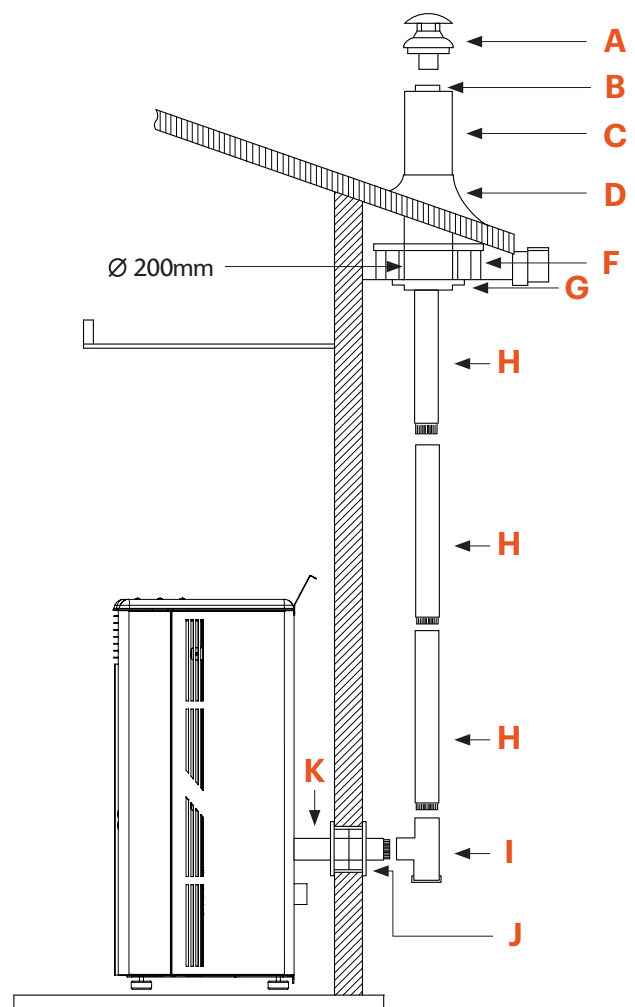

## MASONRY CHIMNEY

When venting into a masonry chimney, the pellet pipe must continue through roof line, clear the masonry chimney and be finished using flashing.

## SURGE PROTECTORS

A surge protector is recommended to ensure the stove's electrical components are not damaged by a surge in the electrical supply. Only a high quality protector should be used.

## THERMOSTAT INSTALLATION

To ensure that the pellet fire is operating at the right temperature, a low voltage thermostat has been installed on the heater. When locating your sensor, ensure it is placed far from the venting pipe. It is important that the sensor is not influenced by any hot or cold objects as this will prevent it from detecting an accurate reading of the room temperature. Choose a place in the room that you believe will detect an even and accurate room temperature.

Please check control board operation on pages 10 - 13.



## WARNING

The appliance must be installed with an authorised person in compliance with Australian/New Zealand standard AS 2918.

# OPERATING INSTRUCTIONS

## 1. INSTALLATION OF DISPLAY

Unpack control panel and fix with screws at the top rear of stove.

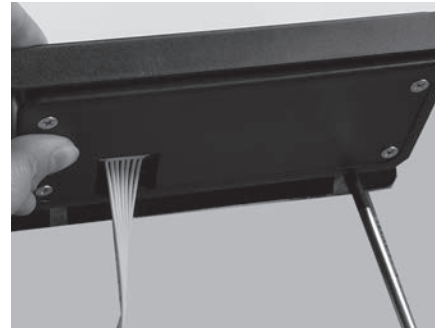
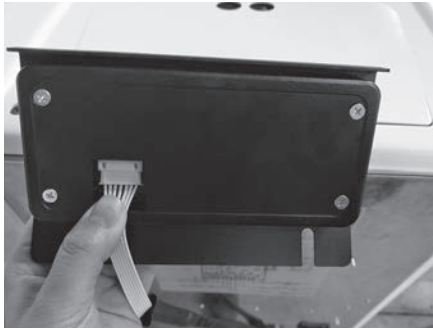

## 2. BEFORE OPERATION

Before igniting please check burn pot, pellet grate and ash box are aligned in proper position.

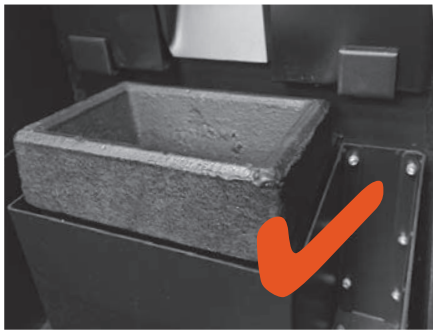

## 3. OPERATING THE HEATER



### WARNING

Only operate this appliance if it has been installed by a licensed installer.

Never operate the heater with the door open.

### INITIALISATION

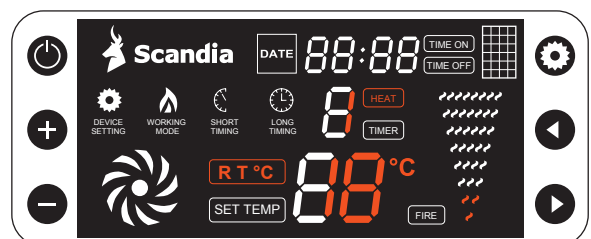

Ensure the burn pot and underside are clean before the stove is started.

1. Ensure power is connected to the heater
2. Turn on the red switch at the back of the heater.  
The display will illuminate.
  - At this point the system will enter self-inspection procedures and display error codes if any errors are detected. (A list of error codes can be found in the trouble shooting section of this manual).
  - Leave this switch on during periods of use. It can be turned off during warmer months and on holidays.
3. Fill the hopper with wood pellets.





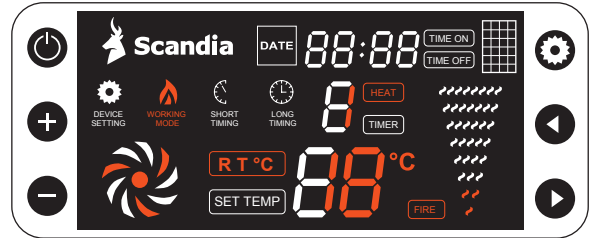

**NOTE:** A slight smell may be apparent for the first few hours of use. This is due to the heat resistant paint curing. It is recommended to open windows and doors for the first lighting.

## MANUAL START-UP and SHUT-DOWN

- ON:** To ignite the heater, press the power button .  
The pellets will slowly be fed from the hopper into the burn pot. You should hear the gentle tingle of pellets as they fall. The heater has an automatic ignition system, it may take up to five minutes for the pellets to ignite. During the ignition process the pellets will produce smoke inside of the firebox; this is normal and should not be of concern.
- Adjust the temperature and fan speed using the remote.
- OFF:** To shut-down the heater press the power button .  
The heater will return to standby mode (dim backlight on display).  
After the stove has been turned off, the pellets in the burn pot will continue to burn for about 15 minutes. During this period the room fan and exhaust fan will continue to operate.





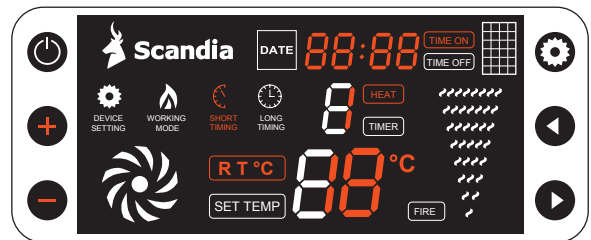

## DELAYED START-UP

- While the heater is in **STANDBY MODE**, press and hold the power button . The time section **88:88**, short timing  and time on  will illuminate.
- Use the  and  buttons to set the time period **88:88** ;  
The timer will start counting down immediately.  
The delay can be set for a maximum of 12 hours.



## DELAYED SHUT-DOWN

- While the heater is running, press and hold the power button .  
The time section **88:88**, short timing  and time off  will illuminate.
- Use the  and  buttons to set the time period **88:88** ;  
The timer will start counting down immediately.  
The delay can be set for a maximum of 12 hours.

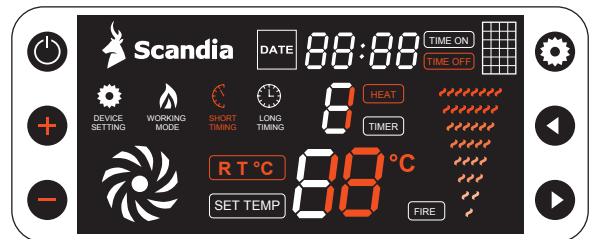

## CLEANING MODE

- CLEANING:** When pellet fire enters into cleaning system, ash cleaning mode will begin automatically.

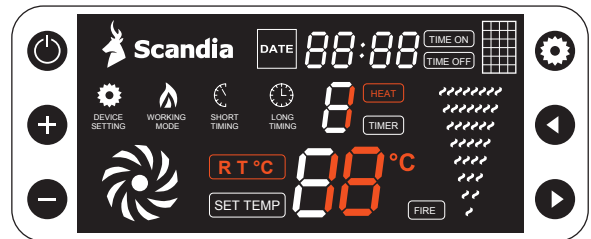

## WARNING

When the stove is switched off, the flame will continue to burn until pellets in the burn pot are burnt out. During this period, system will charge both exhaust fan and flow fan automatically. This burning will last about 15 minutes.









## 4. 7-Day program

Before setting up the 7-day program, confirm that the heater displays the correct time and date. If the time and date need to be adjusted, please refer to the instructions of this manual in Section 5 - Other Settings.

The heater can be set to operate during programmable time-slots over a 7-day period.

**The heater has two time-slots for each Day of the Week.**

To activate a time-slot, we need to enter the start and end time.

- While the heater is in standby, press the Settings Button  until the 'long timing'  icon is flashing.  
The 'time on' icon  should be highlighted (flashing); the day of the week should display 1 and the time slot should show  with the hour field flashing. This indicates that the field 'Day 1, Time-slot 1, Time on, hour' is selected.
- Hour and minute fields for each time-slot are changed with the plus  and minus  icons.  
The time is displayed in 24 hour time.
- To move between fields, use the left  and right  arrows buttons. The order of the fields is shown in the table below.
- To leave a time-slot unused, leave the time displaying 00:00.  
To remove a set time, adjust the time display back to 00:00.
- Once you have completed programming, press the settings button until the RT icon  is highlighted.



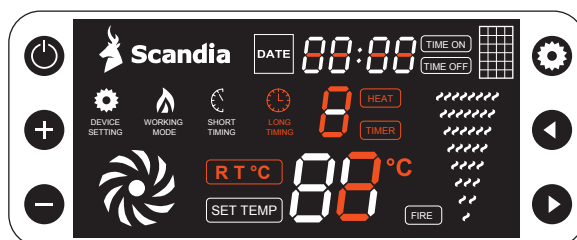
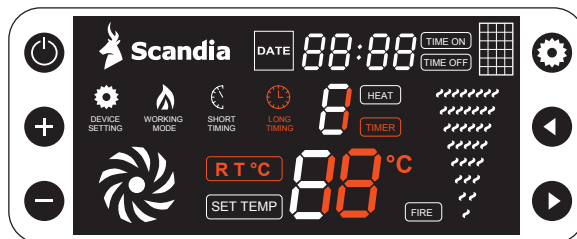



Slot	Field	Order of programming
1	Day 1, Time-slot 1, Time on, hour	First
1	Day 1, Time-slot 1, Time on, minute	Second
1	Day 1, Time-slot 1, Time off, hour	Third
1	Day 1, Time-slot 1, Time off, minute	4th
1	Day 2, Time-slot 1, Time on, hour	5th
1	Day 2, Time-slot 1, Time on, minute	6th
1	Day 2, Time-slot 1, Time off, hour	7th
1	Day 2, Time-slot 1, Time off, minute	8th
	...	
1	Day 7, Time-slot 1, Time on, hour	25th
1	Day 7, Time-slot 1, Time on, minute	26th
1	Day 7, Time-slot 1, Time off, hour	27th
1	Day 7, Time-slot 1, Time off, minute	28th
2	Day 1, Time-slot 2, Time on, hour	29th
2	Day 1, Time-slot 2, Time on, minute	30th
2	Day 1, Time-slot 2, Time off, hour	31st
2	Day 1, Time-slot 2, Time off, minute	32nd
	...	
2	Day 7, Time-slot 2, Time on, hour	53rd
2	Day 7, Time-slot 2, Time on, minute	54th
2	Day 7, Time-slot 2, Time off, hour	55th
2	Day 7, Time-slot 2, Time off, minute	56th



The second slot is indicated by a 2 in the temp section

## 5. OTHER SETTINGS





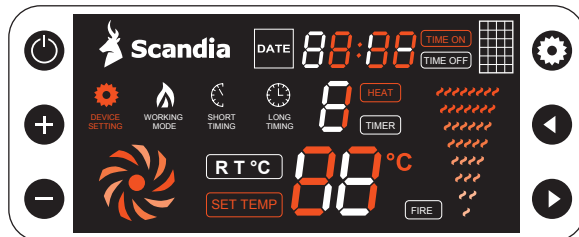

### ADJUSTING THE TEMPERATURE

1. Press the Settings Button  until the 'Set Temp'  icon is highlighted. This can be done either in Standby Mode or while the heater is running.
2. Use the plus  and minus  buttons to adjust the temperature.
3. Once you have set the temperature, press the settings button  until the RT icon  is highlighted.

The maximum temperature that can be set on the unit is 35°C







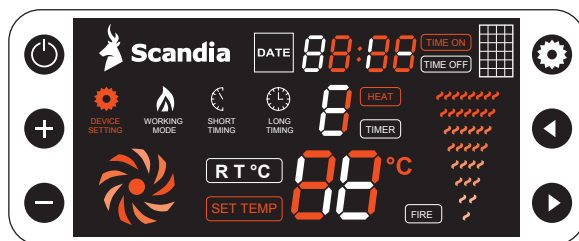



### ADJUSTING THE FAN SPEED

1. Press the Settings Button  until the fan icon  starts spinning, the room temperature field will display a number between 1-4 e.g. 2. This can be done either in standby mode or while the heater is running.
2. Use the plus  and minus  buttons to change the fan speed.
3. Once you have set the fan speed, press the settings button  until the RT icon  is highlighted.



### SETTING TIME



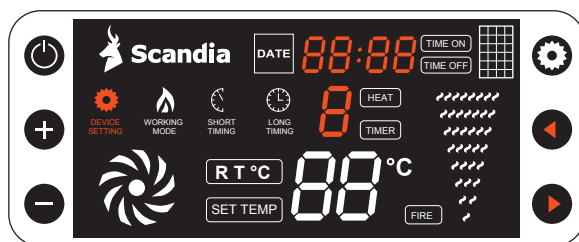



1. While the heater is in standby mode, press the  settings button until the hour, minute or day field is flashing .
2. Use the arrows  or  to change between the hour, minute and day fields.
3. Use the plus  and minus  buttons to adjust the time of day.
4. Once you have set the time, press the settings button  until the RT icon  is highlighted.



## OTHER SETTINGS.... continued

### PELLET FEEDING SETTING

Different brands of pellets may require a different feed rate, this can be established by trial and error. The heater has settings 1-5, with 1 being the shortest feeding time and 5 being the longest feed in time. The factory default is 3.

1. While the heater is in standby mode, press the  settings button until the device setting  and working mode  icons are flashing.
2. Adjust the pellet feed time using the plus  and minus  buttons.
3. Once you have set the pellet feed rate, press the settings button  until the RT icon  is highlighted.

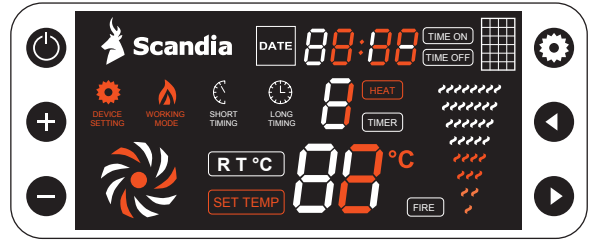

When the interior of the stove reaches 700°C (its maximum temperature), it will automatically stop feeding until the temperature drops to 650°C or below.

### REMOTE CONTROL

The wireless remote control provided with your Scandia pellet fire is the primary controller for stove temperature and fan speed.

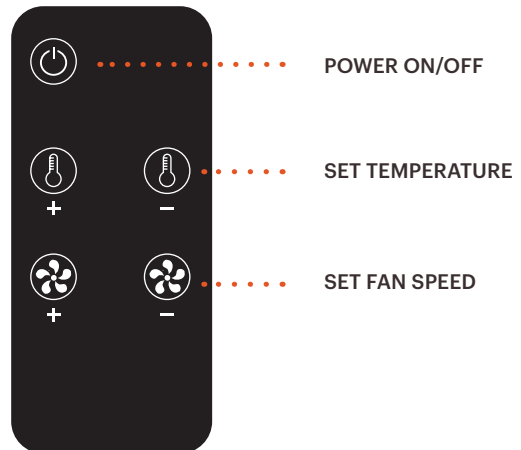

# HEATER MAINTENANCE

Unplug and let the stove cool before any maintenance or cleaning. Some brands of pellets produce more ash and clinkers, therefore stove cleaning frequency greatly depends on the quality of the pellets. Not maintaining a regular cleaning schedule will cause the stove to have a low burning efficiency and void the warranty.

## CLEANING

There will be some ash and small amounts of tar in exhaust pipe. This will vary from pellet ash content and stove operation. The exhaust vent system should be checked and cleaned semi-annually or every two tons of pellets.

- 
1. For maximum efficiency and preventing hot ash flying out, please keep the door closed and sealed during burning. (The burning chamber must always be closed and sealed when the appliance is in operation).
  2. The pellet fire should operate with a bright yellow flame and pellets should be actively burning. If there is a build up of unburnt pellets and large amounts of smoke venting through the heater, follow instructions for cleaning the burn pot.
  3. Do not modify this appliance in any way and only use genuine spare parts installed by a qualified technician when undertaking any repairs.
- 

## BURN POT CLEANING

- 
1. The combustion fan comes on at high speed and blows the by-products of combustion out of the burn pot every hour.
  2. The burn pot should be cleaned thoroughly after burning about 10 bags of pellets.
  3. The burn pot has holes on the bottom and sides which provide combustion air to the pellets. The extreme temperatures in the burn pot can cause the impurities in the pellets to form ash and clinkers. After the stove has cooled down, open front door and remove burn pot. Scrape the inner bottom and sides of burn pot to remove all ash and clinkers with a screwdriver.
  4. Clean igniter bar carefully. Although it is ceramic, it can be easily broken with hard scuffing.
  5. Make sure that all the gaps in the bottom of burn pot are accessible. Place the burn pot in the same position from which it was removed. Ensure that the high side of burn pot is towards the front of the stove. Push the burn pot down so the surface is tight against the steel which supports the pot. Do not substitute for any other grate or pot in this stove.
-



## HEATER MAINTENANCE.... continued

### ASH DRAWER REMOVAL AND CLEANING



- 
1. Do not remove the ash drawer when the stove is hot. Ash disposal should be in a metal container with a tight fitting lid. The closed container should be on a non-combustible floor, or the ground, away from all combustible materials, then to final disposal.

---

  2. If ash is disposed in soil, it should stay in the closed container in the stove until all cinders cool down completely.

---

  3. Put back ash drawer by inserting the drawer into the stove and refasten the left and right latches securely.

---

  4. If the ash drawer does not seal tightly, the control board may detect it and shut down stove.
- 

### VENT PIPE CLEANING

The combustion will contain small particles of fly ash that will collect in exhaust venting system and affect the flow of flue gases.

- 
1. Incomplete combustion, such as start up, shut down, or incorrect operation of pellet fire will lead to soot formation, and that soot will collect in exhaust venting system.

---

  2. The exhaust venting system should be checked at least once a month to see if it needs to be cleaned or not.
-

# HEATER MAINTENANCE.... continued

## CLEANING SCHEDULE AFTER NUMBER OF BAGS BURNED

---

Burn Pot	10 bags
Ash Drawer	10 bags
Blower	50 bags
Flue Fan	100 bags

---

NOTE: Cleaning schedule will vary depending on quality of pellets.  
Pellets with high ash content will require more frequent cleaning.

---

## GLASS CLEANING

There may be times when you need to clean the glass. To do this, use a soft cloth and a non-abrasive glass cleaner. Only ever clean the glass when the pellet fire is cold. For best results select from Scandia's range of glass cleaning products. Always close the door gently. Do not open the door until the pellet fire has fully cooled.

## SURFACE FINISH

To clean your appliance wipe lightly with a damp cloth or dust with a duster. Some cleaning products may leave stains on the heater surface, preferably use Scandia Surface and Glass Cleaner. Never use abrasive cloths as these may scratch the surface; take caution when using microfiber cloths as they can leave swirl marks if used in a circular motion.



## REPLACING PARTS

Always use genuine replacement parts.  
All replacement parts can be ordered from [www.scandiastoves.com.au](http://www.scandiastoves.com.au).

# TROUBLE SHOOTING

Before seeking after-sale services, please check the list below:

## TROUBLESHOOTING – ERROR CODES

1. When the power is on and display shows E1 error message, , the temperature probe (NTC) is failing to work.
2. If display shows E2 , the flame sensor (thermocouple) is failing to work.
3. If ignition fails or fire self-extinguishes at ignition, the display shows E3 . The pellet fire will shut off automatically.

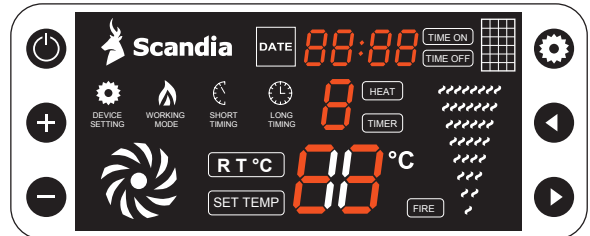

### 1. Light or display fails to illuminate

POSSIBLE CAUSE	REMEDY
No power in stove or in the control panel.	Check the power connection.
Blown fuse.	Replace the fuse.

### 2. The flow fan doesn't work

POSSIBLE CAUSE	REMEDY
Inside temperature is below 130°C.	Wait until the stove temperature reaches 130°C, the flow fan will start.

### 3. Auger doesn't feed pellet

POSSIBLE CAUSE	REMEDY
Auger pipe is blocked.	Clean the auger pipe, use standard pellets.
There is a problem with the connection between feeding motor and auger.	Check if bolts between feeding auger and motor are loose or mismatched. If so, please contact qualified technician.

# TROUBLE SHOOTING.... continued

## 4. Not feeding properly

1. Too many pellets have been added and cannot be burned within the required time.

<b>POSSIBLE CAUSE</b>	<b>REMEDY</b>
The feeding time is too long.	Adjust setting temperature (higher than room temperature by 3 - 6°C), let stove enter into MAX FIRE and let burn down. If still too much, adjust feeding setting to LEVEL 2 or 1 according to pellet quantity.

2. Not enough pellets have been added.

<b>POSSIBLE CAUSE</b>	<b>REMEDY</b>
The feeding time is too short.	Adjust setting temperature (lower than room temperature 3-6°C), let stove enter into MIN FIRE and let burn. If still not enough, adjust feeding setting in LEVEL 4 or 5.

## 5. Stove turns off after ignition

<b>POSSIBLE CAUSE</b>	<b>REMEDY</b>
Feeding system doesn't work.	Check feeding system and refer to PROBLEM #3.
No pellets or pellet feeding time is too slow.	Check the hopper, if empty, add pellets.
Thermocouple cannot detect stove temperature correctly.	The thermocouple is broken, please contact distributor to change the thermocouple.

## 6. Faulty Operation

During operation, fire extinguishes, and powers off automatically. Display shows E3

<b>POSSIBLE CAUSE</b>	<b>REMEDY</b>
The hopper is empty.	Add pellets into the hopper.
No Feeding.	Refer to PROBLEM #3.
Pellet feeding is too slow.	Add more pellets to increase feeding time.

# WIRING DIAGRAM

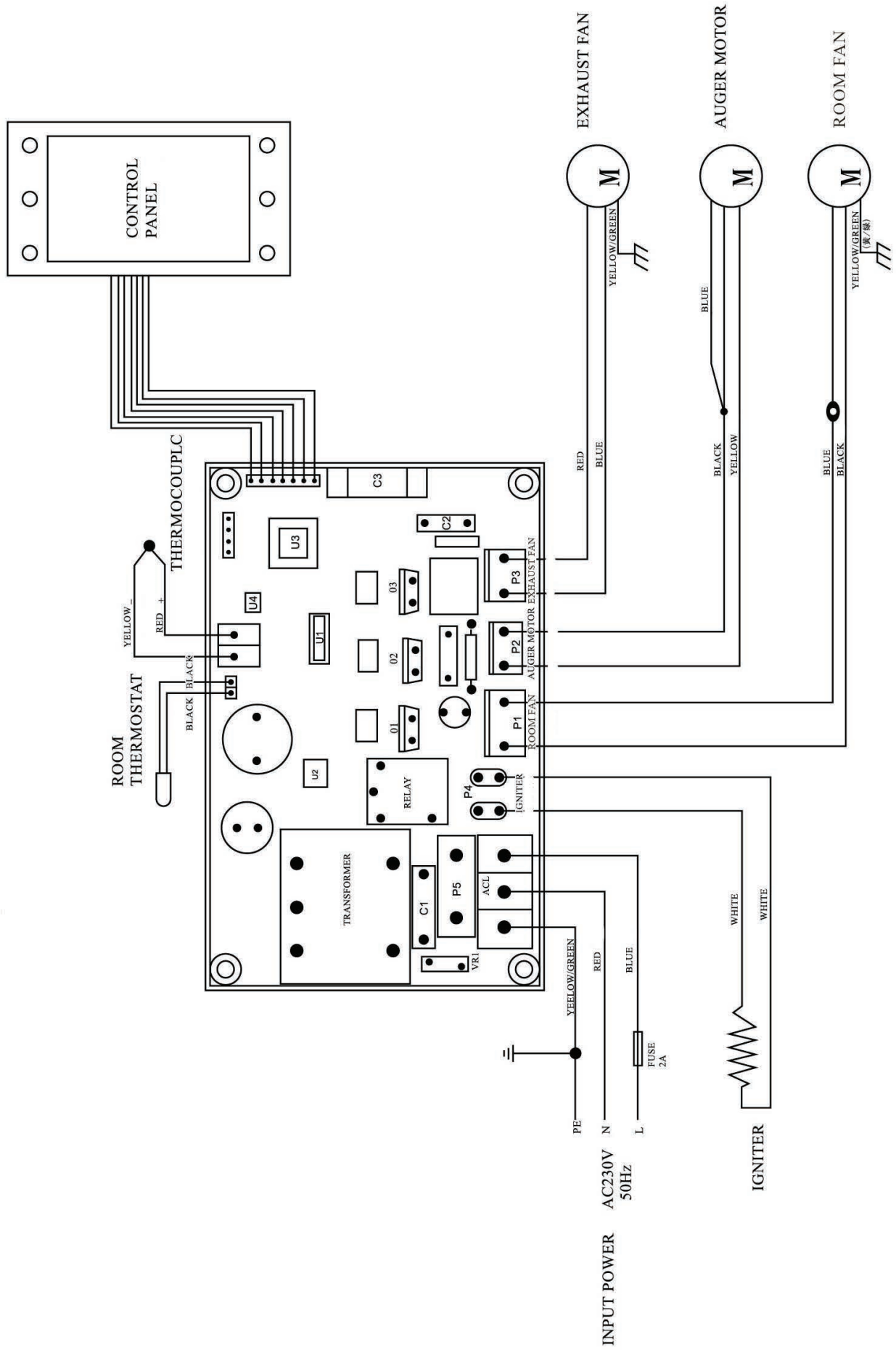

# PELLET HEATER EXPLODED DIAGRAM

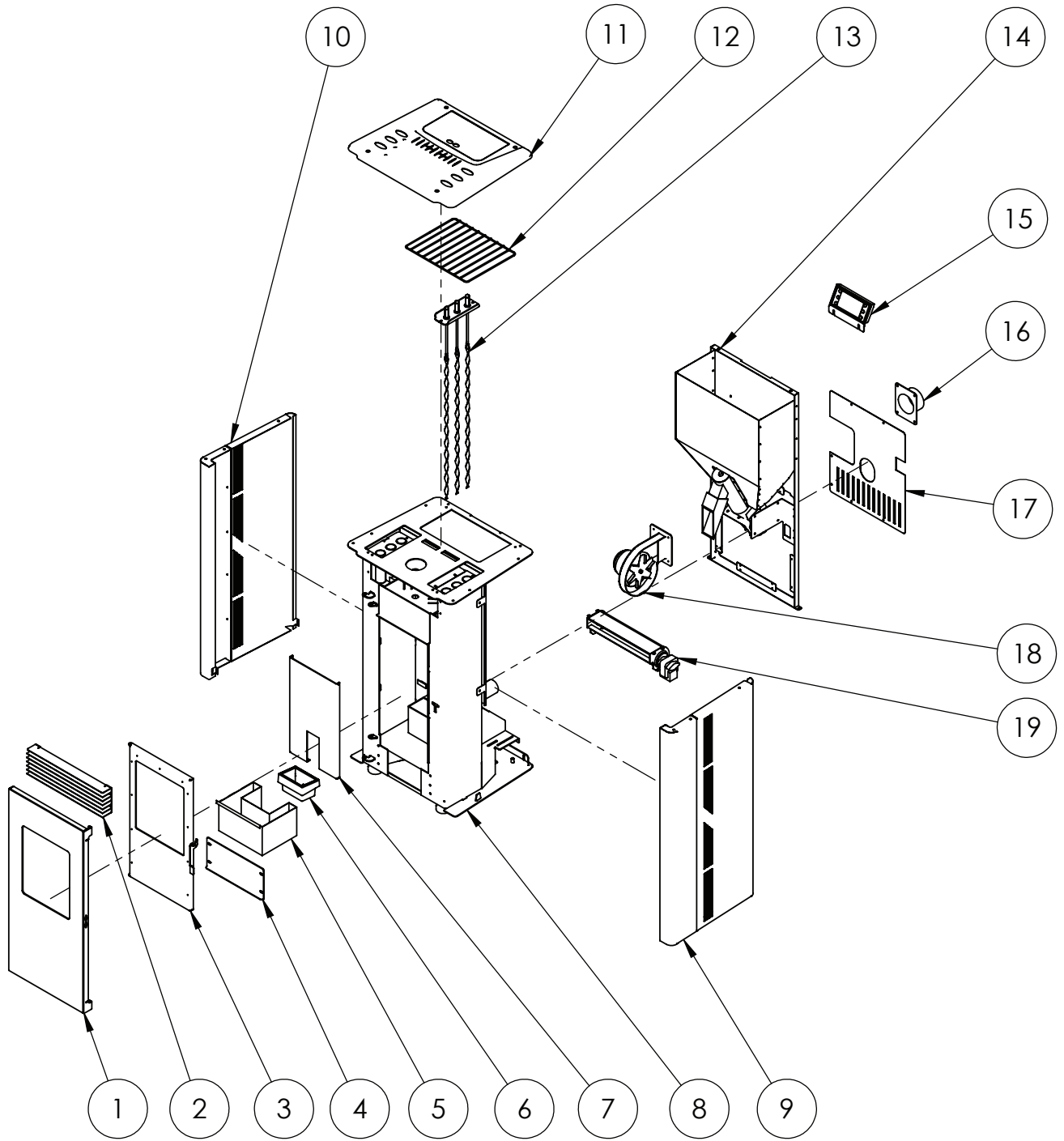

# PELLET HEATER SPARE PARTS LIST

LEGEND	PART	QTY	SCANDIA PART NO.
1	Main Door Assembly	1	SG031000018
2	Room Fan Vent	1	SG031000019
3	Firebox Door Assembly	1	SG031000020
4	Front Inspection Plate	1	SG031000021
5	Ash Tray	1	SG031000022
6	Burner Pot	1	SG031000023
7	Firebox Liner	1	SG031000024
8	Main Body	1	Not Available for Purchase
9	RH Side Panel	1	SG031000025
10	LH Side Panel	1	SG031000026
11	Top Panel	1	SG031000027
12	Hopper Grill	1	SG031000028
13	Heat Exchanger Cleaning Tool	1	SG031000029
14	Hopper and Feeder Assembly	1	SG031000030
15	Control LCD w/ Lead	1	SG030800019
16	Exhaust Flue Spigot	1	SG031000031
17	Rear Inspection Panel	1	SG031000032
18	Flue Fan	1	SG030800020
19	Room Fan	1	SG030800021
Not Shown	Remote	1	SG030800022
Not Shown	Power Lead	1	SG030800023
Not Shown	Fuse	1	SG030800024
Not Shown	Control Board (PCB)	1	SG030800025
Not Shown	Thermostat Sensor	1	SG030800026
Not Shown	Over Temperature Switch	1	SG030800027
Not Shown	Hot surface igniter (igniter bar)	1	SG030800028

# WARRANTY

This limited warranty (**Warranty**) is given by Scandia Heating (Aust) Pty Ltd (ACN 005 868 093) (**Scandia** or **we**) to the original retail purchaser (**You**) of the pellet fire to which this Warranty applies.

**Our goods come with guarantees that cannot be excluded under the Australian/New Zealand Consumer Law. You are entitled to a replacement or refund for a major failure and for compensation for any other reasonably foreseeable loss or damage. You are also entitled to have the goods repaired or replaced if the goods fail to be of acceptable quality and the failure does not amount to a major failure.**

The benefits that this Warranty provides are in addition to other rights and remedies available to you under the Australian/New Zealand Consumer Law. This Warranty does not limit those rights and remedies.

**IMPORTANT:** For this Warranty to apply, you must fully complete the attached card and mail it to our mail address (below) within 30 days after the original purchase. By mailing it to us, you also agree that, to the extent permitted by law, our liability to You on any basis in relation to the pellet fire (other than under the Australian/New Zealand Consumer Law) is limited to our obligations under this Warranty.

## 1. Scope of Warranty

If:

- a defect in material or workmanship appears in the following parts within the corresponding warranty period after the date of the original purchase; and
- you comply with the requirements below regarding making a claim,

then, subject to the exclusions below, we will (or will arrange to) replace or repair the relevant part or (at our option) replace the entire pellet fire with the same or comparable model.

COMPONENT	WARRANTY PERIOD	
	Parts	Labour
Firebox and heat exchanger	5 years	1 year
Burner Pot	2 years	nil
Glass door	1 year	1 year
Electronic components	2 years	1 year
Fan	2 years	1 year
All other parts	1 year	1 year

## 2. Exclusions

This Warranty does not apply:

- if the pellet fire is not installed by a qualified person ;
- where the defect is not due to the original design or manufacture of the part (including where the pellet fire part or accessory has been subject to accident, abuse, alteration, misuse or neglect or has been installed, altered, inspected, operated, cleaned or maintained negligently or not in accordance with applicable local laws, regulations and standards and the instructions and requirement included in the manual supplied with the pellet fire);



## WARRANTY.... continued

- if you are not a retail purchaser, or in the case of non domestic use (e.g. pubs, clubs);
- if the pellet fire has been reinstalled in a different position or location to the original installation;
- to claims relating to the capacity of the pellet fire to heat the desired space;
- to any accessories or optional parts;
- to noise caused by minor expansion, contraction or movement of parts;
- to any initial smell due to paint or surfaces curing;
- to changes in surface finishes as a result of ordinary use (including interior and exterior colour changes or fingerprint marks) or any discolouration of glass;
- to any surface rust which may occur in transit, storage or use;  
This includes installations in close proximity to coastal areas and salt water which may cause rust to the appliance.
- to any defect caused, or likely to have been caused, by an unsuitable environment, including but not limited to:
  - atmospheres containing chlorine or fluorine;
  - prolonged exposure to dampness or condensation; or
  - inadequate air supply or negative pressure caused by tightly sealed construction or air handling devices such as exhaust fans, clothes dryers or forced air furnaces.

### 3. How to make a claim

Any claim under this Warranty must be in writing to our mail or email address below. It must be sent within the applicable warranty period and must include:

- the model number of the pellet fire;
- the place, price and date of purchase; and
- reasonable details of the defect, including both indoor and outdoor images of the installation if the pellet fire has been installed to any extent.

As part of making your claim, You must provide to us any further images or information that we reasonably request, and permit a service person arranged by us to inspect the pellet fire and its installation (if applicable) at a mutually convenient time during business hours.

If you do not provide the required images, or the images or details that you provide are misleading, and an inspection reveals that this warranty does not apply (e.g. due to one of the exclusions above) then we may charge you for the relevant site visit at our applicable rates.

If the pellet fire has not been installed, then at any time we may require that you return the pellet fire to the original place of purchase (and collect it from there once the replacement or repair is complete) at your cost.

## REGISTER YOUR PRODUCT



### REGISTER ONLINE

Register your product warranty online by visiting:

[www.scandiastoves.com.au/warranty](http://www.scandiastoves.com.au/warranty)

Your data will be used by Scandia to provide you with information about your purchase upon request.



### REGISTER BY MAIL

Alternatively, please complete the attached warranty card within 30 days of installation and return to:

**Scandia Group Pty Ltd.**  
**58 Access Way, Carrum Downs**  
**Victoria, Australia, 3201.**

Scandia Heating (Aust) Pty Ltd

+61 3 8579 5900  
[www.scandiastoves.com.au](http://www.scandiastoves.com.au)

Head Office  
58 Access Way,  
Carrum Downs VIC 3201  
Australia









**Scandia**

[www.scandiastoves.com.au](http://www.scandiastoves.com.au)  
1300 HEATER (432 837)