

Installation Guidelines

For

Spark-Ignited Stationary Emergency Generators

Residential and Commercial

22 kW	2.4L
25 kW	1.5L
27 kW	2.4L
30 kW	1.5L
32 kW	2.4L
36 kW	2.4L
38 kW	2.4L
45 kW	2.4L
48 kW	5.4L
60 kW	2.4L

⚠ DANGER!



NOT INTENDED FOR USE IN CRITICAL LIFE SUPPORT APPLICATIONS.



ONLY QUALIFIED ELECTRICIANS OR CONTRACTORS SHOULD ATTEMPT INSTALLATION!



DEADLY EXHAUST FUMES! OUTDOOR INSTALLATION ONLY!

This manual should remain with the unit.

This manual must be used in conjunction with the appropriate owner's manual.

Para español , visita : <http://www.generac.com/service-support/product-support-lookup>

Pour le français, visiter : <http://www.generac.com/service-support/product-support-lookup>

Forward

Purpose and Scope of This Manual

READ THIS MANUAL THOROUGHLY. This manual has been prepared to familiarize personnel involved with the installation of generator sets with the manufacturer's installation requirements. Information and instructions contained herein are not intended to replace or supersede, local, state, or national safety, electrical, and building codes pertaining to such installations. Applicable laws, codes, and standards must always take precedence over the recommendations contained herein. Always check with the local Authority Having Jurisdiction (AHJ) for the codes or standards that apply.

Only authorized dealers or qualified, competent installation contractors or electricians thoroughly familiar with applicable codes, standards, and regulations should install this standby electric power system. The installation must be in strict compliance with all codes, standards, and regulations. Start-up procedures must be performed by an Authorized Generac Service Dealer.

It is not intended that this manual be used by any unqualified person for the purpose of installing a generator set. Installation, inspection, and testing of the system should be attempted only by competent, qualified electricians or installation contractors who are familiar with the equipment and with all installation codes and requirements.

It would be impossible to provide detailed coverage of every installation configuration. For this reason, much of the information contained in this manual is general in nature. Illustrations of typical installations are not intended to serve as detailed installation plans. Always have the drawings and manuals for the specific unit being installed before beginning the installation.

The information in this manual can be used in the planning and design process phase of selecting and purchasing a generator set for a standby power application.

Sources of Information

Installation information and recommendations contained herein are derived from the following sources:

- Knowledgeable engineers, service technicians, and service representatives.
- The National Electric Code (NEC).
- National Fire Protection Association (NFPA) codes and standards.
- Other sources as listed in Subsection 1.7.
- Various manufacturing standards and best practices.

▲ CAUTION!



If this generator is used to power electrical load circuits normally powered by a utility power source, it is required by code to install a transfer switch. The transfer switch must effectively isolate the electric system from the utility distribution system when the generator is operating. Failure to isolate an electrical system by such means may result in damage to the generator and may also result in injury or even death to utility power workers due to backfeed of electrical energy.



If an open bottom is used, the engine-generator is to be installed over non-combustible materials and should be located such that combustible materials are not capable of accumulating under the generator set.



After the system has been installed, do nothing that might render the installation in non-compliance with such codes, standards, and regulations.

Every effort was made to ensure the information in this manual was both accurate and current at the time it was released. However, the manufacturer reserves the right to change, alter, or otherwise improve this product at any time and without prior notice.

Table of Contents

Section 1 Safety

1.1 Introduction	1
1.2 Safety Rules	1
1.3 General Hazards	2
1.4 Electrical Hazards	2
1.5 Fire Hazards	3
1.6 Explosion Hazards	3
1.7 Standards Index	3

Section 2 Installation Planning

2.1 Protector Pre-Order Checklist	5
2.2 Unit Drawings	5
2.2.1 Installation Drawings	5
2.2.2 Wiring Diagrams	6
2.3 Receiving	6
2.3.1 Receiving and Unpacking	6
2.3.2 Inspection	6
2.4 Storage Before Installation	6
2.4.1 Long Term Storage	6
2.4.2 Short Term Storage	6
2.5 Lifting	7
2.6 Generator Location	7
2.6.1 General Location Guidelines	7
2.6.2 Weather Considerations	8
2.7 Accessories	8

Section 3 Foundations & Mounting

3.1 Generator Foundations	11
3.1.1 Concrete Pad	11
3.1.2 Dimensions	11
3.1.3 Unit Clearance	11
3.1.4 Stub Up Area	11
3.2 Mounting	12
3.2.1 Fixed Foundation	12
3.2.2 Connections	12
3.2.3 Combustible Floor and Roof Protection	12

Section 4 Ventilation System

4.1 General	15
4.2 Outdoor Installation Only	15

Section 5 Gaseous Fuel Systems

5.1 General	17
5.1.1 Fuel System Conversion	17
5.2 Gaseous Fuel Properties	17
5.2.1 Natural Gas	17
5.2.2 Propane Vapor (LPV)	17
5.3 Gaseous Fuel Systems	17
5.3.1 Natural Gas System	17
5.3.2 LP-Vapor Withdrawal System	18
5.3.3 Drip Leg	19
5.4 Fuel Pressure Regulators	19
5.4.1 General	19
5.4.2 Definitions	20
5.4.3 Best Practices	20
5.4.4 Operating Fuel Pressure	21
5.4.5 Engine Fuel Consumption	21
5.4.6 Fuel Pressure Regulator Sizing	21
5.4.7 Recommended Fuel Pressure Regulators	22
5.4.8 Primary Fuel Pressure Regulator	22
5.5 Pipe Sizing Considerations	22
5.5.1 General	22
5.5.2 Sizing LP Tanks for Vapor Withdrawal	24
5.6 Final Operating Test	26
5.6.1 Gas Pressure Test Port Location	26
5.6.2 Final Test Procedure	27

Section 6 Electrical System

6.1 General Information	29
6.2 Remove Rear Panel and Stub Up Cover	29
6.3 Wiring Installation Safety	29
6.4 General Wiring Requirements	29
6.5 High Voltage Connections	29
6.6 Control Wiring Connections	32
6.6.1 RTS Series Transfer Switch With T1 Fuse/Connection	32
6.6.2 RTS Series Transfer Switch Without T1 Fuse/Connection	33
6.6.3 Two-Wire Start	33

6.7 Optional Accessory Power	34
6.8 Install Stub Up Cover and Rear Panel	34
6.9 Transfer Switch Location	34
6.10 Battery	34
6.10.1 General Cautions	34
6.10.2 Battery Size	35
6.10.3 Battery Installation	35
6.11 Activate Unit	37
6.12 Operational Checks	38
6.12.1 Self Test	38
6.12.2 Check Manual Transfer Switch Operation	38
6.12.3 Electrical Checks	39
6.12.4 Test Generator Under Load	39
6.12.5 Check Automatic Operation	40
6.13 Installation Summary	40

Section 7 Lube Oil Maintainer System

7.1 Lube Oil Maintainer System	41
7.1.1 Description	41
7.1.2 Fill Oil Supply Tank	42
7.1.3 Test Functionality	42
7.1.4 Shutoff Valve	42

Section 8 Installation Checklists

8.1 Safety Checklist	45
8.2 Installation Planning Checklist	45
8.3 Foundations and Mounting Checklist	45
8.4 Ventilation System Checklist	46
8.5 Exhaust System Checklist	46
8.6 Gaseous Fuel System Checklist	47
8.7 Electrical System Checklist	47
8.8 Oil Maintainer System Checklist	48

Section 9 Installation Drawings

9.1 0K8420-A 25/30 kW (1.5 L).....	49
9.2 0K8624-A 22/27 kW (2.4 L).....	51
9.3 0K8636-A 36/45 kW (2.4 L).....	53
9.4 0K9268-A 32/38 kW (2.4 L).....	55
9.5 0L2090-A 60 kW (2.4 L)	57
9.6 0K9243-A 48 kW (5.4 L).....	59

⚠ WARNING

California Proposition 65. Engine exhaust and some of its constituents are known to the state of California to cause cancer, birth defects, and other reproductive harm. (000004)

⚠ WARNING

California Proposition 65. This product contains or emits chemicals known to the state of California to cause cancer, birth defects, and other reproductive harm. (000005)

Section 1 Safety

1.1 — Introduction

Read this manual thoroughly. If any portion is not understood, contact the nearest Authorized Service Dealer for clarification. The manufacturer also requires having an Authorized Service Dealer oversee the installation of any standby generator set. Trained/qualified service technicians familiar with the control systems and available options have full access to drawings, publications, and other information required for a successful installation.

1.2 — Safety Rules

Throughout this publication, and on tags and decals affixed to the generator, DANGER, WARNING, CAUTION, and NOTE boxes are used to alert personnel to special instructions about a particular operation that may be hazardous if performed incorrectly or carelessly. Observe them carefully. They indicate:

⚠ DANGER!

INDICATES A HAZARDOUS SITUATION OR ACTION WHICH, IF NOT AVOIDED, WILL RESULT IN DEATH OR SERIOUS INJURY.

⚠ WARNING!

Indicates a hazardous situation or action which, if not avoided, could result in death or serious injury.

⚠ CAUTION!

Indicates a hazardous situation which, if not avoided, could result in minor or moderate injury.

NOTE: Notes provide additional information important to a procedure or component.

These safety warnings cannot eliminate the hazards they indicate. Observing safety precautions and strict compliance with the special instructions while performing the action or service are essential to preventing accidents.

Four commonly used safety symbols accompany DANGER, WARNING, and CAUTION boxes and the type of information each indicates:



This symbol points out important safety information that, if not followed, could endanger personnel and/or property.



This symbol represents the potential for an Explosion Hazard.



This symbol represents the potential for a Fire Hazard.



This symbol represents the potential for an Electrical Shock Hazard.



SAVE THESE INSTRUCTIONS. This manual contains important instructions that should be followed during installation of the generator set and batteries. The manufacturer suggests that these safety rules be copied and posted in potential hazard areas. Safety should be stressed to all installers, operators, potential operators, and service and repair technicians for this equipment.

The manufacturer cannot anticipate every possible circumstance that might involve a hazard. The warnings in this manual, and on tags and decals affixed to the unit, are not all-inclusive. If using a procedure, work method, or operating technique the manufacturer does not specifically recommend, ensure that it is safe for others. Also make sure the procedure, work method, or operating technique used does not render the generator unsafe.

- Despite the safe design of this generator, operating this equipment imprudently, neglecting its maintenance, or being careless can cause possible injury or death. Permit only responsible and capable persons to install, operate, and maintain this equipment.
- Parts of the generator are rotating and/or hot during operation. Exercise care near running generators.
- If this generator is used to power electrical load circuits normally powered by a utility power source, install a transfer switch. The transfer switch must effectively isolate the electrical system from the utility distribution system when the generator is operating. Failure to isolate an electrical system by such means will result in damage to the generator and also may result in injury or death to utility power workers due to backfeed of electrical energy.

⚠ DANGER!

 **Generators produce potentially lethal voltages. Ensure all steps are taken to make the generator safe before operation or service.**

1.3 — General Hazards

- For safety reasons, the manufacturer recommends that this equipment be installed, serviced, and repaired by an Authorized Service Dealer or other competent, qualified electrician or installation technician who is familiar with all applicable codes, standards, and regulations.
- Ensure that the generator is installed, operated, and serviced in accordance with the manufacturer's instructions and recommendations. Following installation, do nothing that might render the unit unsafe or in noncompliance.
- The engine exhaust fumes contain carbon monoxide, which can be DEADLY. If breathed in sufficient concentrations, carbon monoxide can cause unconsciousness or even death. For this reason, adequate ventilation must be provided. Exhaust gases must be piped safely away from any building or enclosure that houses the generator to an area where people, animals, etc. will not be harmed.
- Keep hands, feet, clothing, etc. away from drive belts, fans, and other moving or hot parts. Never remove any drive belt or fan guard while the unit is operating. Ensure that all guards, covers, and protective devices removed during maintenance or service are reinstalled.
- Adequate, unobstructed flow of cooling and ventilating air is critical to prevent buildup of explosive gases and to ensure correct generator operation. Do not alter the installation or permit even partial blockage of ventilation provisions, as this can affect safe operation of the generator.
- Keep the area around the generator clean and uncluttered. Remove any materials that could become hazardous.
- When working on this equipment, remain alert at all times. Never work on the equipment when physically or mentally fatigued.
- Inspect the generator regularly, and promptly repair or replace any worn or damaged components using only factory approved parts and procedures.
- Before performing any maintenance on the generator, always disconnect the battery cables to prevent accidental startup. Disconnect the cable from the battery post indicated by a NEGATIVE, NEG, or (–) first, then remove the POSITIVE, POS, or (+) cable. When reconnecting the cables, connect the POSITIVE cable first, the NEGATIVE cable last.
- Never use the generator or any of its parts as a step. Stepping on the unit can stress and break parts, and may result in exhaust, fuel, oil or coolant leaks.

1.4 — Electrical Hazards

- All generators produce dangerous electrical voltages and can cause fatal electrical shock. Utility power delivers extremely high and dangerous voltages to the transfer switch as well as the generator when it is in operation. Avoid contact with bare wires, terminals and other connections. Ensure all covers, guards, and barriers are in place, and that they are properly secured and/or locked before operation. If work must be done around an operating unit, stand on an insulated, dry surface to reduce potential shock hazard.
- Do not handle any kind of electrical device while standing in water, while barefoot, or while hands or feet are wet. DANGEROUS ELECTRICAL SHOCK MAY RESULT.

- If it is necessary to stand on metal or concrete while installing, operating, servicing, or repairing this equipment, lay down a dry wooden platform and cover with insulated mats before beginning.
- Verify that the generator is properly grounded.
- Wire gauge sizes of electrical wiring, cables, and cord sets must be adequate to handle the maximum electrical current (ampacity) to which it will be subjected.
- Before installing or servicing equipment, verify that all power voltage supplies are positively turned off at their sources. Failure to do so can result in hazardous and possibly fatal electrical shock.
- Connecting this unit to an electrical system normally supplied by an electric utility is by means of a transfer switch so as to isolate the generator electric system from the electric utility distribution system when the generator is operating. Failure to isolate the two electric system power sources from each other by such means will result in damage to the generator and may also result in injury or death to utility power workers due to backfeed of electrical energy.
- Generators installed with an automatic transfer switch will crank and start automatically when NORMAL (UTILITY) source voltage is removed or is below an acceptable preset level. To prevent automatic startup and possible injury, disable the automatic start circuit (battery cables, etc.) before working on or around the unit. Place a “DO NOT OPERATE” tag on the generator control panel and on the transfer switch.
- In case of accident caused by electric shock, immediately shut down the source of electrical power. If this is not possible, attempt to free the victim from the live conductor. AVOID DIRECT CONTACT WITH THE VICTIM. Use a nonconducting implement, such as a dry rope or board, to free the victim from the live conductor. If the victim is unconscious, apply first aid and get immediate medical help.
- Do not wear jewelry when working on this equipment. Jewelry can conduct electricity resulting in electric shock, or may get caught in moving parts resulting in injury.

1.5 — Fire Hazards

- Keep a fire extinguisher near the generator at all times. Keep the extinguisher properly charged and be familiar with its use. Direct any questions to the local fire department.

NOTE: DO NOT use any carbon tetra-chloride type fire extinguishers. These fire extinguishers emit toxic fumes and the liquid can damage wiring insulation.

1.6 — Explosion Hazards

- Properly ventilate the room or building housing the generator to prevent buildup of explosive gas.
- Do not smoke around the generator. Immediately wipe up any fuel or oil spills. Ensure that no combustible materials are left in the generator compartment, or on or near the generator, as FIRE or EXPLOSION may result. Keep the area surrounding the generator clean and free of debris.
- All types of fuels are potentially FLAMMABLE and/or EXPLOSIVE and must be handled with care. Inspect the fuel system frequently and correct any leaks immediately. Be sure fuel supply lines are properly installed, purged, and leak tested before placing the generator set into service.

1.7 — Standards Index

Be sure the generator set is in strict compliance with all applicable local, state, and federal laws, codes, and regulations pertaining to such installations. Always use the current version or edition of the applicable law, code, and regulation as it applies to the local jurisdiction. In the absence of pertinent local laws and standards, use the following published materials as a guide.

1. National Fire Protection Association (NFPA) 70: The National Electric Code (NEC)*
2. NFPA10: Standard for Portable Fire Extinguishers*
3. NFPA 30: Flammable and Combustible Liquids Code*
4. NFPA 37: Standard for Stationary Combustion Engines and Gas Turbines*
5. NFPA 54: National Fuel Gas Code*
6. NFPA 58: Standard for Storage and Handling of Liquefied Petroleum Gases*

7. NFPA 68: Standard on Explosion Protection by Deflagration Venting*
8. NFPA 70E: Standard for Electrical Safety in the Workplace*
9. NFPA 211: Standard for Chimneys, Fireplaces, Vents, and Solid Fuel Burning Appliances*
10. NFPA 220: Standard on Types of Building Construction*
11. NFPA 5000: Building Code*
12. International Building Code**
13. Agricultural Wiring Handbook***
14. ASAE EP-364.2 Installation and Maintenance of Farm Standby Electric Power****

This list is not all inclusive. Check with the Authority Having Local Jurisdiction (AHJ) for any local codes or standards which may be applicable to the jurisdiction where the generator is installed. The above listed standards are available from the following internet sources:

* www.nfpa.org

** www.iccsafe.org

*** www.nerc.org Rural Electricity Resource Council; P.O. Box 309; Wilmington, OH 45177-0309

**** www.asabe.org American Society of Agricultural & Biological Engineers; 2950 Niles Road; St. Joseph, MI 49085

Section 2 Installation Planning

⚠ DANGER!



Connecting this generator to an electrical system normally supplied by an electric utility shall be by means of a transfer switch, so as to isolate the electric system from the utility distribution system when the generator is operating. Failure to isolate the electric system by these means will result in damage to the generator and may also result in injury or death to utility workers due to backfeed of electrical energy.

NOTE: Only authorized dealers or qualified, competent installation contractors or electricians thoroughly familiar with applicable codes, standards and regulations should install this standby electric power system. The installation must comply strictly with all codes, standards and regulations pertaining to the installation.

2.1 — Protector Pre-Order Checklist

- The local fire marshal has confirmed that the generator must be located a minimum of _____ feet from a house or other structure.
NOTE: Generac recommends a minimum clearance of five feet from a combustible surface Per NFPA 37, Section 4.1.4.
- The local AHJ has advised me regarding the requirements for electrical and/or building permits, as well as those regulations relating to emissions and fuel storage.
- I have been advised of the local requirements for construction of a concrete base pad, and whether anchoring requirements are needed for installation on a flood plain.
- I have confirmed with the appropriate authorities that the generator must be located a minimum of _____ feet from a property line.
- I have been advised whether the local fire marshal (or other third party) is required to be present at start up.
- I have confirmed that the installation site is applicable to optional standby only and does not require an NFPA 110 capable generator.

2.2 — Unit Drawings

2.2.1— Installation Drawings

Installation drawings show weights, dimensions, clearances, exhaust details, connection locations, wiring stub-ups, lifting locations, and other information. Use the unit specific installation drawings when designing a site installation plan. Thoroughly read the NOTES section of each drawing for important details.

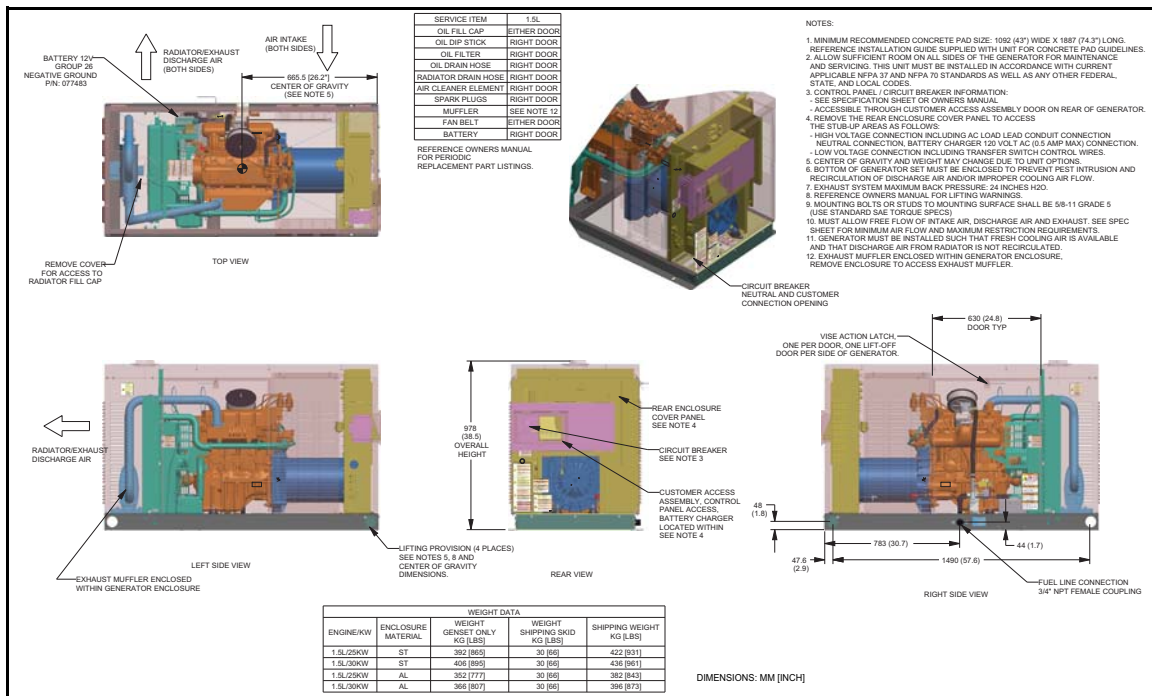

Figure 2-1. Typical Installation Drawing

2.2.2— Wiring Diagrams

Wiring and schematic diagrams show the connection points for control wiring, load wiring, and any service power supply required for battery chargers, block heaters, etc. Always use the unit specific wiring diagrams during planning and installation.

2.3 — Receiving

2.3.1— Receiving and Unpacking

When applicable, handle shipping cartons and crates with care to avoid damage. Store and unpack cartons with the correct side up, as noted by the label on the shipping carton.

2.3.2— Inspection

Carefully inspect the generator set and all contents of cartons for any damage that may have occurred during shipment. See the shipping documentation for any provisions or guidance when damage is incurred. Correct all damage or deficiencies before installation of the generator set.

2.4 — Storage Before Installation

2.4.1— Long Term Storage

If the unit is to be stored (or installed and not started-up) for six months or more, preserve in accordance with the manufacturer’s instructions. Contact the local Authorized Service Dealer to obtain the Long Term Preservation and Storage Manual (Part No. 0G4018) and the Preservation Checklist (Part No. 0G4018A).

2.4.2— Short Term Storage

If the unit is to be stored (or installed and not started-up) for less than six months, proceed as follows:

- All units are provided with an enclosure.

- Place the unit on a smooth flat surface. Do not leave unit on the shipping pallet, as it leaves the bottom open for entry of dirt, debris, insects, rodents, etc.
- If applicable, cover any exhaust system openings.
- Leave plastic plugs in fuel connection points.
- Use anti-rodent plugs and other enclosure features to prevent entry of birds, small animals, and foreign objects.

2.5 — Lifting

⚠ WARNING!



When lifting or hoisting equipment is used, be careful not to touch any overhead power lines. Generators that weigh more than 900 pounds require proper tools, equipment, and qualified personnel to be used in all phases of handling and unpacking.

To ensure personal safety and prevent damage to the unit, use only properly sized equipment intended for safe rigging, lifting and moving of heavy machinery.

Use a spreader bar to prevent damage to the unit. **Failure to use a spreader bar will result in scratches and damage to painted surfaces.**

Installation drawings show the lifting points for rigging and lifting purposes. Always attach lifting and rigging devices at the designated points only. Do not use the lifting points of the engine or alternator to move the generator set. See Figure 2-2.

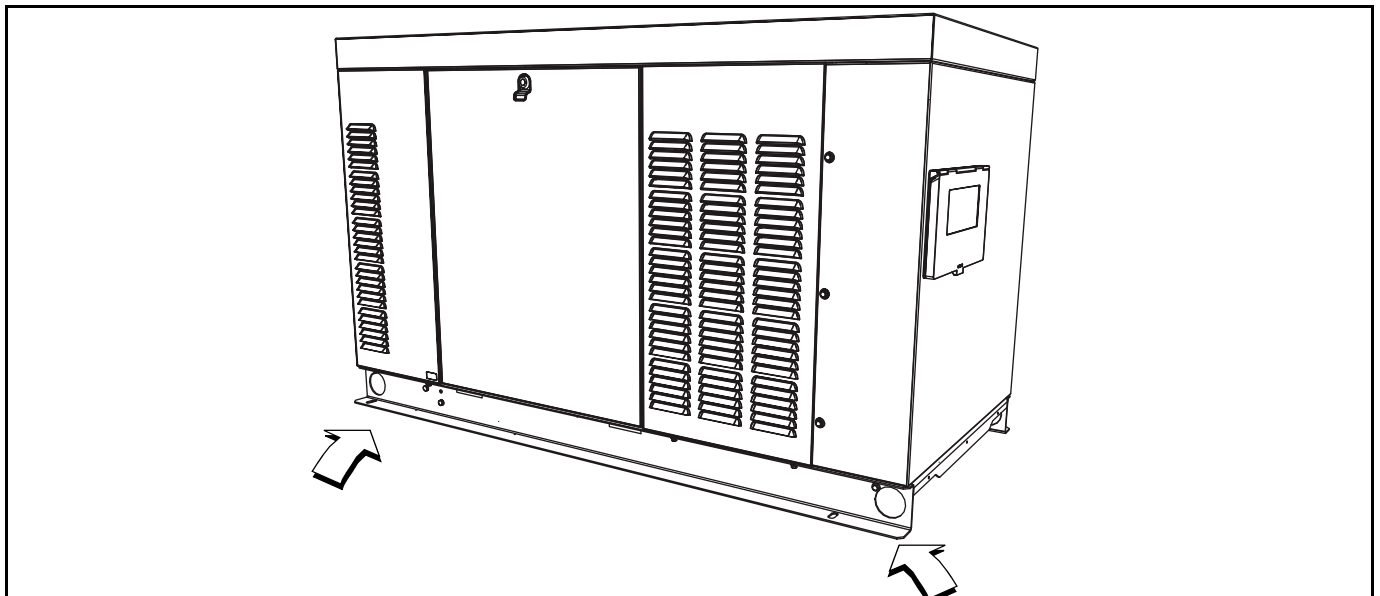

**Figure 2-2. Lifting Points (Four Places)
C1 Enclosure shown (22/25/27/30 kW)**

2.6 — Generator Location

Locate the generator set so that it is readily accessible for maintenance, repair, and firefighting purposes. Comply with code requirements for minimum distance from combustible walls and building openings.

2.6.1— General Location Guidelines

Consider the following:

- The supporting structure must be adequate for the generator set and its accessories.

- Be sure the site is clean, dry, not subject to flooding, and provided with adequate drainage in the event of heavy rains.
- Be sure the location permits noise and vibration to be effectively isolated.
- Verify that the site provides easy access to the generator set for maintenance, repair, and firefighting purposes.
- Keep a minimum of five (5) feet of clearance around each side of the generator set to facilitate service or maintenance.
- Be sure the location permits engine exhaust gases to be safely evacuated from inhabited or occupied areas. Consider the direction of prevailing winds to prevent exhaust gases from being carried back to the engine area or to the fresh air intake vents of nearby buildings.
- The site must allow for the provision of an adequate fuel supply.
- Be sure the location permits sufficient air flow for cooling and ventilation. Consider the proximity of any walls, fences, or other noise abatement or security barriers. Do NOT face the radiator discharge end of the enclosure into the prevailing wind.
- Consider cold weather kit options and accessories for the generator in cold weather locations.
- Verify that the unit is securely fastened to the mounting pad to prevent movement caused by vibration.
- Verify that all electrical connections have flexible sections to isolate vibration.
- Verify that the fuel pressure and pipe is sized correctly and that it has the appropriate flex hose.

NOTE: Failure to comply with the location guidelines can result in damage to the generator or surrounding area and may cause the warranty to be suspended or voided. Extra repair labor or equipment may not be covered under the warranty if service access is difficult or restricted.

2.6.2— Weather Considerations

Consider local weather conditions during installation. There are various accessories available to ensure fast, reliable starting and operation regardless of local climatic conditions. Optional cold weather kits make starting of the engine more dependable and reliable.

2.7 — Accessories

The following product accessories are available. Contact a Dealer for additional information.

1. Scheduled Maintenance Kit
2. Cold Weather Kit
3. Extreme Cold Weather Kit
4. Mobile Link
5. Mobile Link Harness Adapter Kit*
6. Wireless Local Monitor
7. Wireless Local Monitor Harness Adapter Kit*
8. Smart Management Module
9. Emergency Stop Switch
10. Base Plug Kit
11. Touch-Up Paint Kit

*Required for liquid-cooled applications

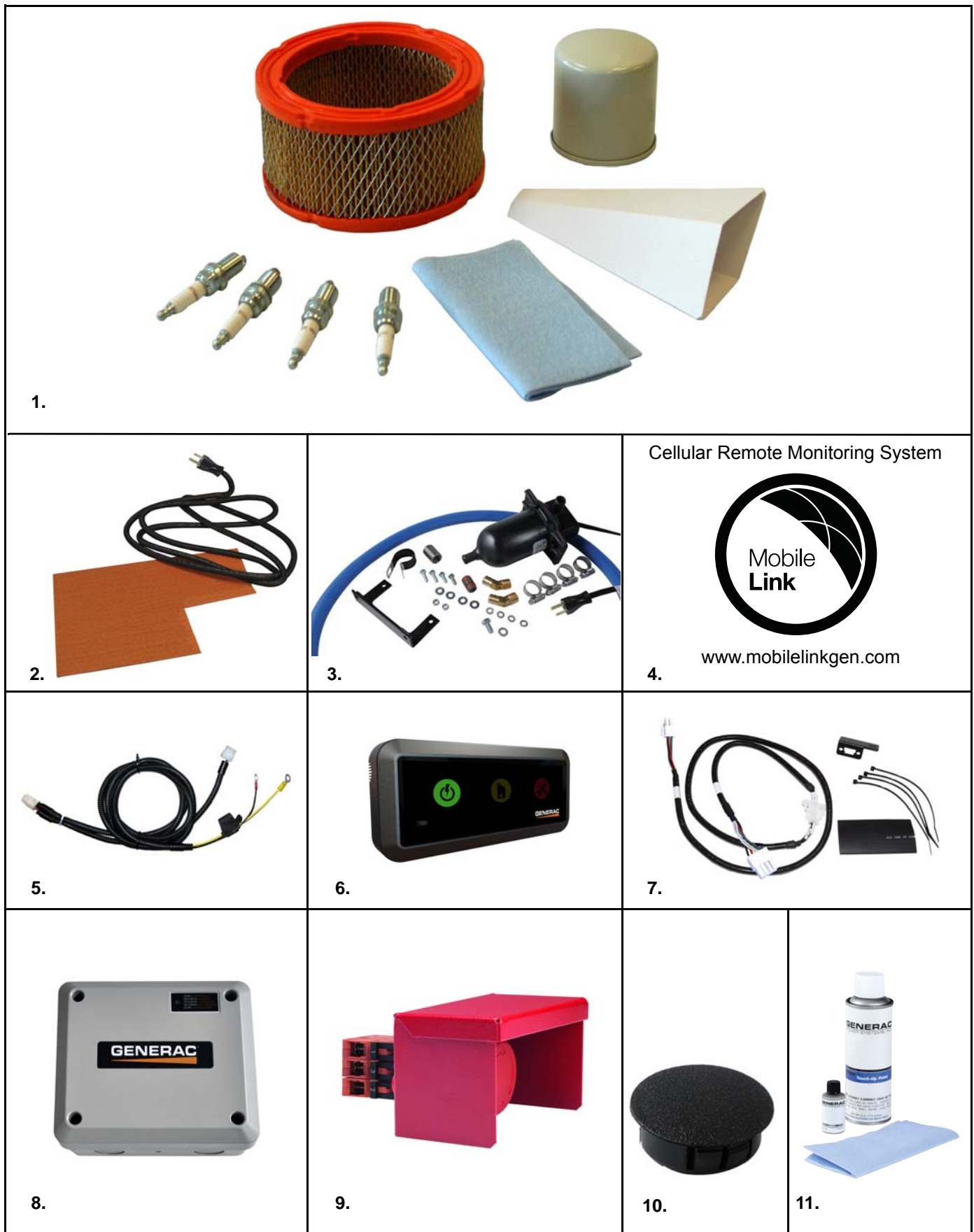

Figure 2-3. Product Accessories

This page intentionally left blank.

Section 3 Foundations & Mounting

3.1 — Generator Foundations

Install the generator set on a concrete pad or base slab able to support its weight and accessories. A proper foundation is needed to resist dynamic loading and reduce transmitted noise and vibration. The exact composition of the mounting pad must follow standard engineering practices for the required loading and application. **Securely fasten the generator set to the foundation using suitable grade, size and style fasteners.** Holes are provided in the base frame for this purpose.

3.1.1— Concrete Pad

Follow all federal, state, and local codes when designing a concrete pad or base slab.

Seat the concrete pad on a prepared solid subsurface and use appropriate reinforcing bar or expanded wire mesh. A common specification calls for 2500 psi concrete reinforced with 8 gauge wire mesh or number 6 reinforcing bars on six (6) inch centers.

3.1.2— Dimensions

Extend the concrete pad beyond the frame of the unit at least six (6) inches. This provides a mounting surface for fuel line support, as well as space for maintenance and repair.

The base pad must be:

- Capable of supporting 125% of the unit wet weight for single unit applications.
- Flat and level to within 1/2 inch.
- Capable of withstanding severe torque reactions.

To calculate the depth of the concrete pad, the following formula may be used:

$$\text{Depth of Base} = \frac{W}{150 \times B \times L}$$

W = Total wet weight of generator set in pounds (kg)

150 = Density of the concrete (pounds per cubic foot)

2400 = Density of concrete (kilograms per cubic foot)

B = Foundation width in feet (meters)

L = Foundation length in feet (meters)

Suggested mixture of concrete (by volume) is 1:2:3 of cement, sand, and aggregate with a maximum four inch (100mm) slump with a 28 day compression strength of 3000 psi (200 MPa).

3.1.3— Unit Clearance

Verify that the site provides easy access to the generator set for maintenance, repair, and firefighting purposes. Keep a minimum of 5 feet of clearance around each side of the generator set to facilitate service or maintenance.

3.1.4— Stub Up Area

For load conduit, auxiliary power conduit (high voltage), and control wiring conduit (low voltage), see the installation drawings for the location and dimensions of the stub up areas. See Figure 3-1.

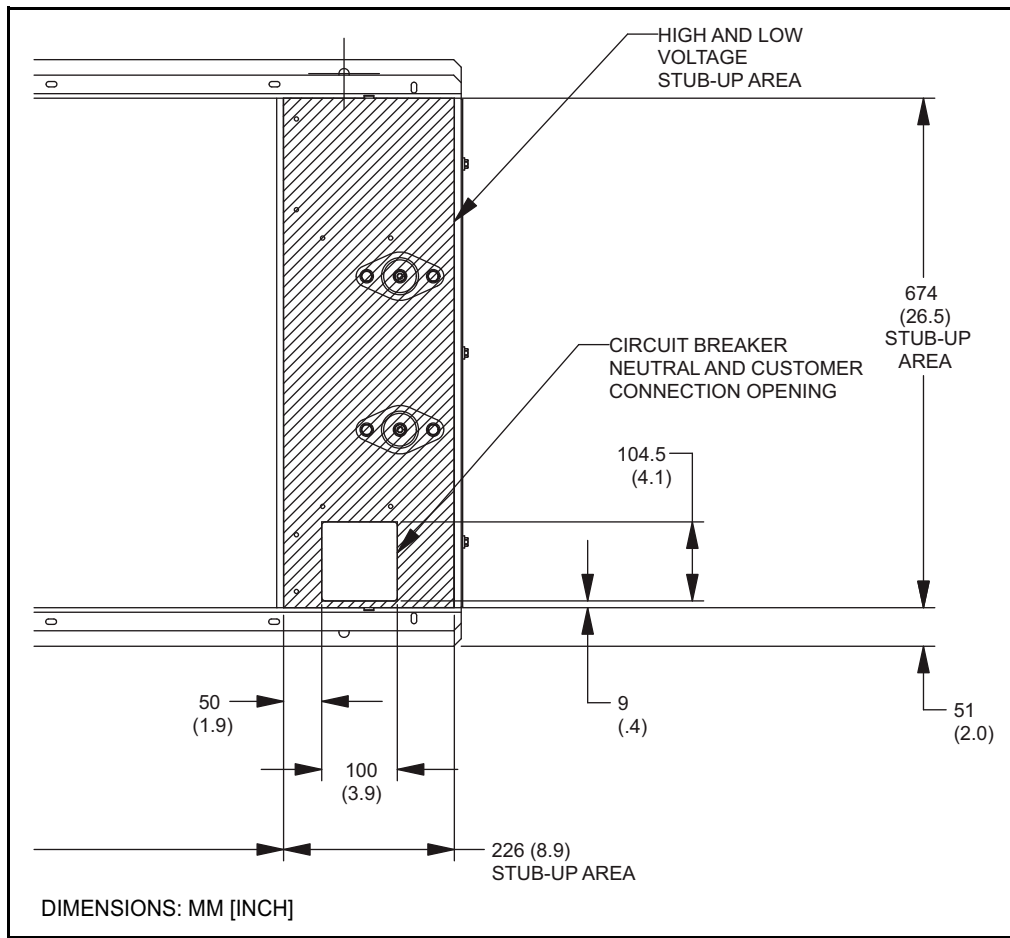

Figure 3-1. Typical Installation Drawing Stub Up Detail

3.2 — Mounting

3.2.1— Fixed Foundation

Use mounting holes in the base frame to fasten the unit to the foundation. Always use hardware of a suitable grade, size and style.

3.2.2— Connections

All electrical connections must have flexible sections where they connect to the unit to isolate vibration. Properly support and secure all piping before installing the flexible connection.

3.2.3— Combustible Floor and Roof Protection

If the generator set must be installed on any combustible floor or roof, comply with the following rules:

- Place a layer of non-combustible insulation, followed by a layer of sheet metal, beneath the unit's mounting base rails.
- Both the layer of insulation and the sheet metal must extend beyond the engine-generator base, to a distance of at least six (6) inches (15.25cm) on all sides. See Figure 3-2.

For rooftop or building structure mounting, it is recommended that spring isolators be installed between the engine frame and the mounting system. A minimum of 6 isolators are required and must be located at the front and rear cross members and center of the frame.

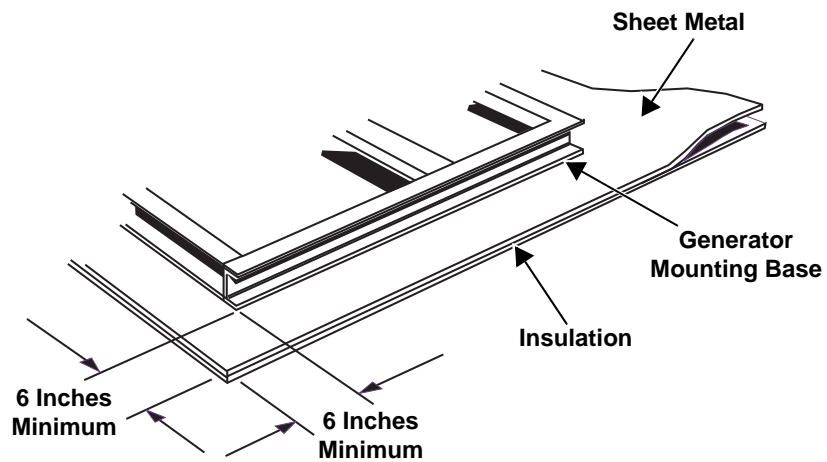

Figure 3-2. Combustible Floor and Roof Protection.

Since the entire bottom of the genset is now exposed, it should be covered with a sheet metal plate to keep out small animals and protect the integrity of the internal parts of the genset. Genset movement is more intense with spring isolation, therefore flexible connections for the fuel and the electrical conduits are also required.

NOTE: Consult local building codes which may vary

This page intentionally left blank.

Section 4 Ventilation System

4.1 — General

Adequate and unobstructed flow of cooling and ventilating air is critical to prevent buildup of explosive gases and to ensure safe generator operation. Do not alter the installation or permit even partial blockage of ventilation provisions. Keep area around the generator clean and uncluttered, and remove any materials that may pose a hazard.

4.2 — Outdoor Installation Only

The unit is for outdoor installation only. The installation design must ensure that there are no obstructions at any of the air intakes that may impede intake airflow.

This page intentionally left blank.

Section 5 Gaseous Fuel Systems



Gaseous fuels, such as LP and natural gas, are highly volatile and their vapors are explosive. LP gas is heavier than air and will settle in low areas. Natural gas is lighter than air and will settle in high areas. Even the slightest spark can ignite these fuels and cause an explosion.

5.1 — General

Consult a local gas distributor or licensed plumber/installer when installing a gaseous fuel supply system or refer to information published by various federal agencies. For a list of some of these publications, see Subsection 1.7.

5.1.1— Fuel System Conversion

Industrial units come from the factory configured and EPA certified with the fuel system ordered. Any one of the following gaseous fuel systems may be installed:

- Natural Gas (NG)
- LP-Vapor Withdrawal

To convert to a different fuel (for example, from NG to LP-Gas Vapor), see the owner's manual or an independent authorized service dealer.

5.2 — Gaseous Fuel Properties

5.2.1— Natural Gas

Natural gas is lighter than air. It is found in the gaseous state at normal ambient temperatures and pressures. It is highly explosive and can be ignited by the slightest spark. For this reason, fuel lines must be free of leaks and adequate ventilation is absolutely essential. Local fuel/gas codes dictate the maximum pressure under which natural gas can be delivered to a site or structure. The supply pressure from the utility meter/regulator is usually not the same as that required by the generator set, so a separate primary regulator providing the correct pressure and volume of fuel to the generator set is required. If the local utility source pressure is **less** than that required by the generator, it is up to the local utility to provide the volume of gas at the required pressure.

5.2.2— Propane Vapor (LPV)

Liquefied Petroleum gas is heavier than air. The gas vapors are explosive and can be ignited by the slightest spark. LP Vapor is supplied by liquid propane stored in tanks. Propane exists in its liquid form at or below its boiling point (-44° F) as well as when it is stored under pressure. LP tank pressure is dependent on the ambient temperature and the liquid volume in the tank, and can be over 200 psi. A first-stage regulator at the tank reduces the gas pressure to a lower line pressure value. This line pressure is then reduced to the correct operating pressure and volume for the generator set through the use of a second-stage regulator.

5.3 — Gaseous Fuel Systems

5.3.1— Natural Gas System

The local utility will usually provide the piping (meter and pressure regulator) from the main distribution line to the generator site. The local utility is also responsible for providing gas at sufficient volume and pressure to operate the primary regulator, so that the regulator can provide the correct volume of gas at the required pressure to the generator.

From the primary regulator, gas flows to the generator connection point, which is the end of the manufacturer supplied flexible fuel line. The flexible fuel line can be connected directly to the generator connection point (perpendicular to the frame rail), or by an elbow and short nipple to the frame rail itself (to run parallel to the frame rail). The nipple and elbow used must be the same pipe size as the flexible fuel line and generator connection point. Install a flexible fuel line

between the rigid supply piping and the gas connection at the generator, and must be installed straight without bends or kinks. The primary regulator outlet and the generator connection point must be sized correctly to provide the generator with the required volume and pressure when it is operating at 100% of its rated load.

On the generator the unit mounted regulator (it may be either a demand regulator or a pressure regulator) and its associated shutoff valves control the flow and pressure to the unit for proper operation. The fuel pressure required for the generator to operate is always measured at the inlet of the unit mounted regulator. For the location of the pressure test connection, see Subsection 5.6.1. The supply pressure and volume must meet the requirements described in the unit specification sheet. If specifications are not met, the generator will not operate properly and will probably display symptoms, such as hard starting, rough running, inability to carry load, and erratic operation.

NOTE: Gas pressure from the primary regulator (supplied by the installing contractor) to the generator's fuel shutoff valve should be between 5-14 inches W.C.

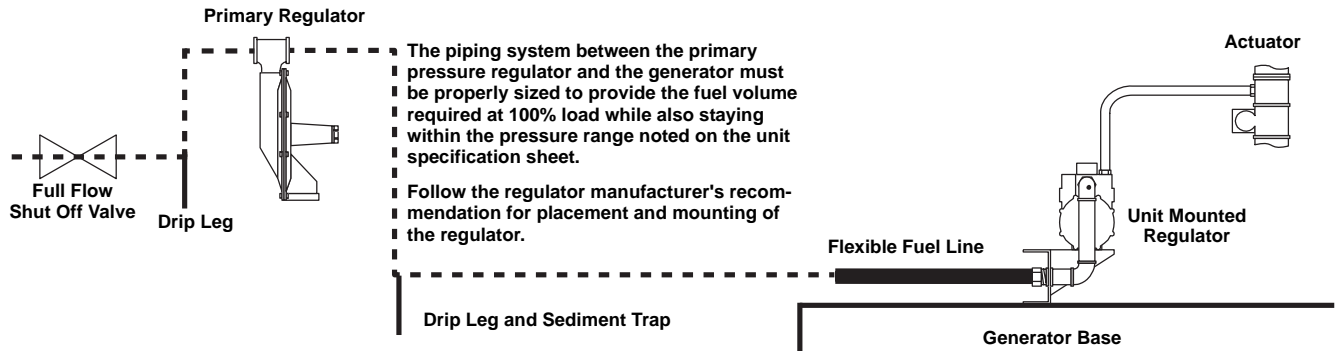

Figure 5-1. Typical NG Fuel System

5.3.2— LP-Vapor Withdrawal System

This type of system uses the vapors formed above the liquid fuel in the supply tank. The maximum tank fill capacity is 80% and a minimum of approximately 20% of the tank capacity is needed for fuel expansion from the liquid to vapor state. Gas pressure and volume requirements for an LP-Gas vapor system at the connection point of the generator are listed on the unit specification sheet.

Pressure regulation for vapor withdrawal systems is typically a two-step process. First, by reducing the high tank pressure to a lower line pressure with a first-stage regulator, then reducing the line pressure to the pressure required by the unit with a second-stage regulator. Both regulators and the associated system piping and valves need to be sized correctly to provide the generator with the required volume and pressure of fuel at the generator connection point.

NOTE: Gas pressure from the primary regulator (supplied by the installing contractor) to the generator's fuel shutoff valve should be between 5-14 inches W.C.

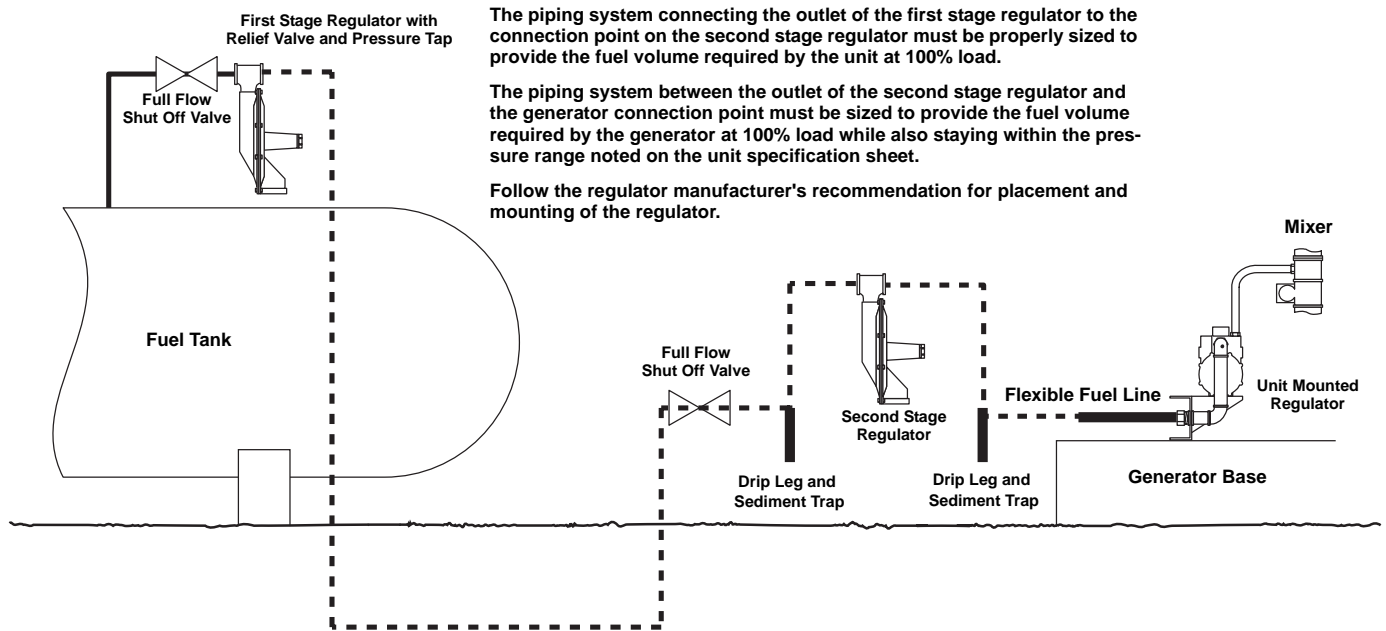

Figure 5-2. Typical LP-Vapor Withdrawal Fuel System

5.3.3— Drip Leg

Install at least one drip leg (sediment trap) before the unit to separate sediment, debris, and condensation from the gas flow. A drip leg is also recommended at the bottom of a vertical pipe run and after each change in direction. Drip legs protect downstream equipment, such as the primary or second stage pressure regulators, from clogging and contamination. Some installations and/or jurisdictions may require no drip legs, or multiple drip legs. Consult the local AHJ for requirements.

5.4 — Fuel Pressure Regulators

5.4.1— General

One of the most common causes of a generator set not operating properly is improper sizing and installation of the gaseous fuel supply system between the meter (utility source) and the generator connection. The fuel supply system consists of a primary regulator to regulate the flow and volume from the source (utility supply) to the generator, and all of the associated piping, fittings, and shutoff valves, both upstream (feeding the main meter/regulator) and downstream (between the meter and primary regulator), which connect the fuel source to the connection point on the generator. The fuel supply system must be capable of supplying the correct volume of fuel within the correct pressure range to the connection point on the generator. The volume of fuel and operating pressure required are listed in the technical specifications for the applicable generator. Fuel pressure at the unit must remain within the specified operating range and not drop below the minimum pressure specified.

5.4.2— Definitions

The following definitions are provided for use in this manual.

Table 5-1. Definitions

Term	Description
Allowable Pressure Drop	The design pressure loss in the system under maximum probable flow conditions, from the point of delivery to the inlet connection of the generator set, shall be such that the supply pressure at the generator is greater than or equal to the minimum pressure required by the generator at its full load capacity.
Authority Having Jurisdiction (AHJ) (NFPA-54)	An organization, office, or individual responsible for enforcing the requirements of a code or standard, or for approving equipment, materials, an installation, or a procedure.
Cubic Foot (ft ³) of Gas (NFPA-54)	The amount of gas that would occupy 1 ft ³ when at a temperature of 600° F saturated with water vapor and under a pressure equivalent to 30 in. w.c.
Generator Connection Point	The connection point for the fuel supply system to the generator set is the end of the manufacturer supplied flexible hose fitting which connects to the fitting on the base frame of the generator. An elbow and short nipple can be incorporated to allow the flexible hose to be positioned parallel to the unit base frame. The size of the connection point on the base frame is shown in each unit's installation drawing; the size of the flexible hose (and any elbow and nipple) must be equal to or larger than this connection point. The flexible hose must be installed straight without bending, twisting or kinking.
psi & psig	Measure of pressure in pounds per square inch and pounds per square inch gauge.
Inches of Water Column (in.w.c.)	Measure of pressure in inches of water column (in. w.c.). 14 in. w.c. = approximately 0.5 psi.
Primary Regulator	A pressure regulator installed between the service regulator (NG) or first-stage regulator (LP-Gas vapor) sized to provide the pressure and volume required by the generator at its full rated load capacity.
Regulator (for LP-Gas vapor)	
First-Stage Regulator	A pressure regulator for LP-Gas vapor service designed to reduce pressure from a container to 10.0 psig or less.
High-Pressure Regulator	A pressure regulator for LP-Gas liquid or vapor service designed to reduce pressure from the container to a lower pressure in excess of 1.0 psig.
Second-Stage Regulator	A pressure regulator for LP-Gas vapor service designed to reduce first-stage regulator outlet pressure to 14 in. w.c. or less. For generator set purposes, this is also referred to as the Primary Regulator.
Regulator (for NG fuel)	
Pressure Regulator	Device placed in a gas line for reducing, controlling, and maintaining pressure in downstream piping
Service Regulator	A pressure regulator installed by the servicing gas supplier to reduce and limit the service line gas pressure to delivery pressure.

5.4.3— Best Practices

These are the manufacturer recommended best practices for configuring and sizing fuel supply piping to generators. These best practices have been developed specifically for the manufacturer's product and may not represent conventional gaseous fuel system sizing methods, particularly those used frequently with low volume appliance installations. Compliance with these best practices will help to ensure the generator set engine will operate properly under dynamic conditions.

- The minimum distance from the primary pressure regulator outlet to the generator connection point will be covered in the regulator manufacturer's installation instructions. Do not connect the pressure regulator directly to the flexible fuel line on the generator. The piping between the primary pressure regulator and the connection point on the generator acts as a reservoir (accumulator) which stores gas and, therefore, can minimize or maximize the changes in delivery pressure that the generator sees during cranking and load changes.

- The required fuel pressure to the unit is measured before the fuel shutoff solenoids at the inlet to the unit mounted regulator. A 1/8 inch pipe port in the pressure regulator body, or in the piping just before the pressure regulator, is provided for this purpose. See Subsection 5.6.1.
- Seasonal supply pressure changes to the primary pressure regulator can affect the proper operation of the generator. The fuel supply pressure to the unit must remain within the specified operating parameters as stated in the unit specification sheet. Contact the local utility to find out what can be done to correct seasonal changes.
- Use sediment traps.
- The generator set must have its own dedicated fuel supply. Do not connect any other loads to the outlet of the primary pressure regulator.

For LP-Vapor systems, due to the nature of the conversion process from LP liquid to LP vapor, consider the following:

- The vaporization rate of a given LP tank is dependent on the liquid level in the tank (wetted surface area), the ambient temperature around the tank, and relative humidity.
- When ambient temperatures are below 40° F, engine fuel consumption is high, and sufficient humidity is present, condensation can occur resulting in frosting of the tank at the liquid level. This condition can lead to a reduced rate of vaporization. See the LP tank sizing section for more information.

5.4.4— Operating Fuel Pressure

The unit specification sheet lists the operating fuel pressure range, as well as the 100% load fuel consumption rate. The pressure range is the minimum and maximum acceptable pressures for proper operation of the unit under all operating conditions. The maximum fuel system pressure drop at each condition, that is, static, cranking, running at no load, and running at full load, is 1-2 in. w.c. as measured at the primary fuel pressure regulator. For definitions of each condition, see Subsection 5.6.2.

5.4.5— Engine Fuel Consumption

The volume of gaseous fuel consumed at various loads is listed in the unit specification sheet. Both Natural Gas and LP-Vapor values are provided in Cubic Feet per Hour (CFH). International units of measure are also provided.

Use the following formulas if it becomes necessary to convert CFH to BTUs per Hour:

- **Natural Gas:** $CFH \times 1000 = BTU \text{ per hour}$

- **LP-Vapor:** $CFH \times 2520 = BTU \text{ per hour}$

5.4.6— Fuel Pressure Regulator Sizing

Fuel pressure regulators are designed to automatically adjust flow to meet downstream demand at a required pressure. The typical regulator installed as the primary regulator for a generator set is of the direct acting, internally registered design. Direct acting means that the pressure sensing element acts directly to open the valve and control the flow to the load while maintaining the desired pressure. The pressure sensing element is typically a diaphragm which is opposed by a combination of spring pressure and atmospheric pressure. The valve is the restricting element and consists of some type of variable restriction (cone, poppet, disc) which closes against a fixed seat. Internal registration means that the pressure used for sensing comes from within the valve body, usually through a passage from the secondary side (outlet) to the sensing diaphragm.

The primary regulator must be sized to provide the required flow at the rated pressure to the generator at its full load capacity. The generator fuel consumption values and required operating pressures are listed in the unit specification sheet.

The manufacturer recommends that the primary pressure regulator be sized for at least 110% of the generator's required fuel consumption at 100% load, and that the regulator provide no more than a 1-2 inch w.c. pressure drop at each operating condition, that is, static, cranking, running at no load, and running at full load.

Various regulator manufacturers provide sizing tables, flow capacity, pressure drop tables, and distributors who will help size a regulator correctly to a system.

5.4.7— Recommended Fuel Pressure Regulators

Use only direct acting fuel pressure regulators, such as those made by **Fisher®** or **Maxitrol®** or any other listed regulator manufacturer.

5.4.8— Primary Fuel Pressure Regulator

The following are the recommended “best practices” with regard to specifying, sizing, and installing the primary fuel pressure regulator.

1. Verify that the regulator:
 - Is sized to have a fuel flow delivery rating (CFH) at least 10% greater than the 100% rated kW fuel consumption requirement of the generator.
NOTE: The recommended selection for orifice diameters is to use the smallest orifice that will still provide a CFH fuel flow rate at least 1.1 times greater than the required full load CFH rating of the generator set.
 - Is approved for a mechanized engine application. A standard HVAC type regulator or standard appliance regulator is prohibited.
 - Has an accuracy rating of 1% or less and/or have a maximum allowable pressure droop rate of 1-2 inches w.c.
NOTE: Droop is the reduction of outlet pressure experienced by pressure-reducing regulators as the flow rate increases. It is stated as a percent, in inches of water column, or in pounds per square inch, and indicates the difference between the outlet pressure at low flow rates and the outlet pressure at the published maximum flow rate. Droop is also called offset or proportional band. For proper generator operation, a maximum of 1-2 in. w.c. droop is required at each operating condition, that is, static, cranking, running at no load, and running at full load.
 - Has a spring rating within the range of 5 to 14 inches w.c.
2. Be sure that the generator has a dedicated fuel supply which is not shared with any other appliances (furnace, water heaters, ranges, etc.).
3. Check the inlet pressure measured at the regulator body inlet connection when the regulator appears unable to pass the published flow rate. Supply piping up to the regulator can cause significant flowing pressure losses.
4. Be sure the regulator is flowing at least five percent of the normal operating flow when adjusting the pressure set point.
5. Expect approximately a one degree drop in gas temperature for every 15 psid (differential) across the regulator due to the natural refrigeration effect.
NOTE: Freezing is often a problem when the ambient temperature is between 30° and 45° F (-1° and 7° C), particularly with LP-V systems.
6. Point vents down to help avoid the accumulation of water condensation or other materials in the spring case.
7. Keep vents open. Do not use long, small diameter vent lines. Follow the rule-of-thumb: use the next nominal pipe size for every ten feet of vent line, and use three feet of vent line for every elbow in the line.
8. The connection point on the generator is the end of the manufacturer supplied flex hose. The flex hose is the same size as the connection point on the generator frame rail (see installation drawings). It is permissible to install one elbow (90°) and a short nipple between the flex hose and frame rail connection point to allow the flex hose to parallel the frame rail for installation purposes.

5.5 — Pipe Sizing Considerations

5.5.1— General

Consult a local gas distributor or licensed installer when sizing and installing the piping for any gaseous fuel supply system. When using a local gas distributor or installer, be sure they have the proper documentation to support their recommendations. The fuel system requirements and best practices conveyed in this manual must be provided to the representative responsible for sizing the fuel system. The final test of the system is measuring the fuel pressure as described in Subsection 5.6.1. If the pressure requirements are not met, then the fuel supply system is not correct.

There are several pipe sizing programs available for use on the Internet and from various manufacturers. If used it is highly recommended that the minimum pressure drop value always be used (0.5 inches w.c or less). This will ensure that the piping system is sized correctly to handle the generator set volume at full load, and during cranking and load transients, while also remaining above the minimum operating pressure.

The following general rules apply to piping of gaseous fuel systems:

- Use black iron piping or other approved gas line. Pipe must be rigidly mounted and protected against vibration.
- Install the supplied or recommended length of flexible hose between the generator connection point and the rigid supply piping. Install the flexible hose straight without bends, twists or kinks. Do not install the flexible hose underground or in contact with the ground.
- Install a drip leg and sediment trap. (Consult local AHJ for requirements)
- Correctly size the piping to maintain the required supply pressure and volume under varying load conditions.
- Properly purge and leak test installed piping.
- Use an approved pipe sealant or joint compound on all threaded fittings to reduce the possibility of leakage.
- Make provision for a fuel shutoff valve near the unit. Verify that the fuel shutoff valve is installed correctly and works properly.
- Using suitable methods, check entire pipe run for leaks.

Table 5-2. Fuel Pipe Sizing for Natural Gas (NG)

Natural Gas 5" to 14" of Water Column						
Table values are maximum pipe run in feet.						
	Pipe Size (inches)					
kW	1 in	1.25 in	1.5 in	2 in	2.5 in	3 in
22	20	100	200	750	—	—
25	10	80	175	575	—	—
27	—	85	203	552	—	—
30	—	60	125	450	—	—
35-36	—	35	95	370	915	—
45	—	15	60	260	650	—
48	—	—	50	230	585	—
60	—	—	25	145	375	1100

Natural Gas
1 cubic foot = 1,000 BTU
1 therm = 100,000 BTU
Gas consumption = 13,000-16,000 BTU per kW/hr

Pressure
1 inch mercury = 13.61 inches water column
1 inch Water Column = 0.036 psi
3.5–14 inches water column = 0.126 psi to 0.50 psi

Note:

- Pipe sizing is based on 0.5" H₂O pressure drop.
- Sizing includes a nominal number of elbows and tees.
- Please verify adequate service and meter sizing.
- Tables based on black pipe.

Note: Size the fuel pipe to the sizing charts or to local codes. When installing other than Sch. 40 black pipe, please refer to the manufactures sizing charts.
The liquid-cooled generator is not a constant flow appliance, the fuel pipe was sized large enough to supply at least 125% of the generator BTU/hr rating.

Table 5-3. Fuel Pipe Sizing for Natural Gas (NG)

LP Vapor (LPV) 11" to 14" of Water Column					
Table values are maximum pipe run in feet.					
	Pipe Size (inches)				
kW	1 in	1.25 in	1.5 in	2 in	2.5 in
22	85	365	—	—	—
25	60	275	605	—	—
27	55	260	575	—	—
30	40	195	435	—	—
35-36	20	125	290	1030	—
45	—	82	195	725	—
48	—	70	165	620	—
60	—	45	115	445	1095

LP
LPG: 8.55 ft³/lb., 4.24 lbs./gal., 2500 btu/ft³
LPG: 36.3 ft³ = 1 gal.

Pressure
1 inch mercury = 13.61 inches water column
1 inch Water Column = 0.036 psi
11–14 inches water column = 0.396 psi to 0.50 psi

Note:

- Pipe sizing is based on 0.5" H₂O pressure drop.
- Sizing includes a nominal number of elbows and tees.
- Please verify adequate service and meter sizing.
- Tables based on black pipe.

Note: Size the fuel pipe to the sizing charts or to local codes. When installing other than Sch. 40 black pipe, please refer to the manufactures sizing charts.
The liquid-cooled generator is not a constant flow appliance, the fuel pipe was sized large enough to supply at least 125% of the generator BTU/hr rating.

5.5.2— Sizing LP Tanks for Vapor Withdrawal

The manufacturer recommends that the installer consult with a reputable LP supplier when sizing LP storage tanks and their associated pressure regulators and piping systems. Many factors come into play when working with LP in either its vapor or liquid form.

The operation of an LP-Vapor system depends on the vaporization of the liquid stored in the tanks. As the vapor above the liquid level is withdrawn the pressure in the tank decreases. This change in pressure causes the liquid to “boil” in order to restore the pressure equilibrium. The liquid in the tank uses the temperature difference between its boiling point (-44° F for Propane) and the outside temperature to extract enough heat to enable vaporization (boiling). Only the liquid in contact with the tank wall absorbs heat from the outside. The area of the tank where the liquid is in contact with the tank wall is referred to as the “wetted surface area”. Cold weather results in a reduced tank vaporization capacity because there is less heat energy available to boil off the liquid into vapor. The wetted surface area of the tank must be large enough to sustain the vaporization rate required by the generator. Depending on the relative humidity and the ambient temperature, frosting can occur on the outside of the tank when it is in use. This condition further inhibits the heat transfer required to sustain vaporization.

Several factors affect the rate of vaporization for LP tanks:

- The size of the tank (wetted surface area). As the wetted surface area decreases the rate of vaporization decreases.
- The lowest liquid level the tank will be allowed to reach (relates directly to the wetted surface area). The typical maximum fill level for LP tanks is 80%, and the lowest recommended operating level is 20%. This provides a volume equivalent to 60% of the tank capacity to be used to calculate run time. Most tank sizing tables provide the vaporization rate of the tank at the lowest allowable level (20%); any tank level above this point will have a higher vaporization rate.
- The lowest normal temperature expected. Typical tank tables provide vaporization rates at 40° F, 20° F, and 0° F. For temperatures below 0° F consult a reputable LP dealer for options.
- The mean relative humidity.

To size an LP tank for a desired run time the following information is required:

- The maximum vapor consumption of the generator (in BTU/hr) at 100% load. The specification sheet for the generator will list the fuel consumption rate, usually in cubic feet per hour. To convert CFH to BTU/hr, multiply by 2520.
- The fuel consumption rate in gallons per hour with the generator at 100% load. To convert CFH (propane vapor) to GPH, divide by 36.38. To convert BTU/hr to GPH, divide by 91502.
- The desired run time.
- The minimum operating temperature expected.

The most important thing to consider when sizing LP tanks for vapor withdrawal is the vaporization rate of the tank at the minimum temperature expected, and at the minimum fuel level the tank will be allowed to reach. The vaporization rates shown in Table 5-4 are based on the tank at 20% of its fill capacity.

1. Multiply the gallons per hour fuel consumption rate of the generator at 100% load by the longest run time expected/desired.
2. Determine the fuel consumption in BTU/hr with the generator at 100% load.
3. Determine the lowest expected operating temperature.
4. See Table 5-4. Using both the Minimum Operating Temperature and the Tank Vaporization Capacity columns, find the BTU/hr vaporization rate of the generator at 100% load that corresponds to the lowest expected operating temperature.
5. Look back at column 2, note the Available Tank Capacity. If it is greater than the total run time fuel consumption refer back to column 1- this is the correct size tank required. If it is less than the total run time fuel consumption, then go to the next larger tank size. Recheck the lowest operating temperature and the tank vaporization capacity.

Table 5-4. Vaporization Rates

Tank Capacity Total (gal) See Note 1	Available Tank Capacity (gal) See Note 2	Minimum Operating Temperature (° F)	Tank Vaporization Capacity (BTU/hr) See Note 3	Length (In.)	Diameter (In.)
250	150	40 20 0	507,600 338,400 169,200	94	30
325	195	40 20 0	642,600 428,400 214,200	119	30
500	300	40 20 0	792,540 528,360 264,180	119	37
850	510	40 20 0	1,217,700 811,800 405,900	165	41
1000	600	40 20 0	1,416,960 944,640 472,620	192	41
<p>Note 1: The minimum LP tank size is 250 gallons, unless unit calculations dictate use of a larger tank. Vertical tanks, which are measured in pounds, will not usually meet the minimum tank size (250 Gallons x 4.20 Pounds = approximately a 1050 pound vertical tank minimum).</p> <p>Note 2: The available tank capacity is approximately 60% of the total fill capacity. This is based on a maximum fill level of 80% and a minimum operating level of 20% (80%-20% = 60%).</p> <p>Note 3: The vaporization capacity shown is based on a tank level of 20%. This represents the smallest allowable wetted surface area of the liquid in the tank. As the liquid level goes up, the wetted surface area and the vaporization rate increases.</p>					

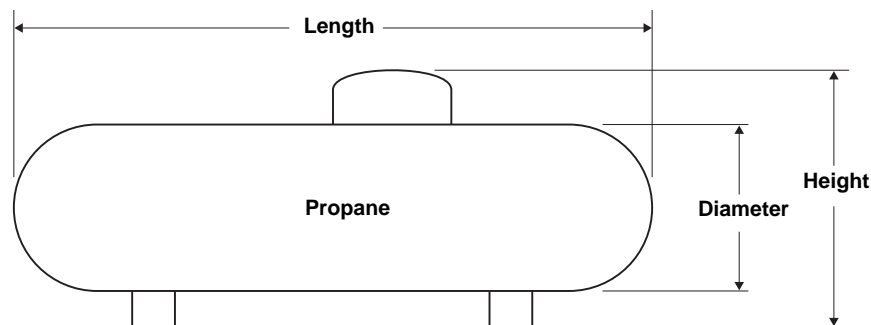

Figure 5-3. Typical Propane Tank Dimensions

NOTE: The minimum LP tank size is 250 gallons, unless unit calculations dictate use of a larger tank. Vertical tanks, which are measured in pounds, will not usually meet the minimum tank size (250 Gallons x 4.20 Pounds = approximately a 1050 pound vertical tank minimum).

Propane conversion figures:

- 36.38 ft³ = 90,500 Btu = 1 gal
- 1 lb = 21,500 Btu = 8.56 ft³
- 2500 Btu = 1 ft³

5.6 — Final Operating Test

A properly configured and sized fuel system provides the fuel volume and fuel pressure required for the generator set to operate correctly in all modes of operation. To confirm proper fuel system operation, a series of tests must be performed as further described below.

5.6.1— Gas Pressure Test Port Location

Using a suitable pressure gauge or water manometer, measure the gas pressure to the generator at a test port located before the fuel solenoid shutoff valve(s).

See A of Figure 5-4. On units using the demand type regulator(s), there may be a factory installed 1/8 inch pipe port in a tee fitting connected to the low pressure switch.

See B of Figure 5-4. If the unit has a low pressure switch without the tee, install a tee and plug between the low pressure switch and the test port on the regulator body using a suitable pipe dope. Use only the upper port on the regulator body, as it detects supply gas pressure even when the unit solenoid valve is closed. This allows static pressure to be measured, as well as pressure when cranking, while running at no load, and while running at full load.

See C of Figure 5-4. Factory installed at the test point, some units may be provided with a special test port plug known as a "Pete's Plug." The plug allows fuel pressure test readings to be taken quickly without leaving costly gauges installed in the line.

Use the "Pete's Plug" as follows:

1. Clean and lubricate gauge adapter probe with a small amount of petroleum jelly or silicone grease.
2. Assemble gauge adapter.
3. Using the appropriate sealant, screw barbed fitting into gauge adapter.
4. Install fuel hose of the proper pressure gauge onto barbed fitting.
5. Slowly unscrew protective cap from the test port plug.

NOTE: Quickly tighten the cap if escaping gas or liquid is heard or felt. Replace the plug if defective.

6. Insert gauge adapter into test port plug and secure.
7. Once the fuel pressure reading is obtained, remove gauge adapter probe and screw protective cap onto fuel pressure test port plug.

NOTE: Take necessary readings as quickly as possible. Severe deformation of the valves may occur if gauge adapter probe is left in the test port plug for a period of hours or days.

NOTE: Below 45° F. the neoprene core of the plug does not recover it's original shape as rapidly as it would at higher temperatures. Therefore, upon removal of the gauge adapter probe, the valves may not close fully and immediately, or they may remain slightly open until the operating temperature is above 45° F. Lower pressures and the length of time the gauge adapter probe is inserted also can affect the valve closing rate. The protective cap is provided to eliminate the small amount of leakage that might occur following removal of the gauge adapter probe.

8. Tighten protective cap to prevent tampering.

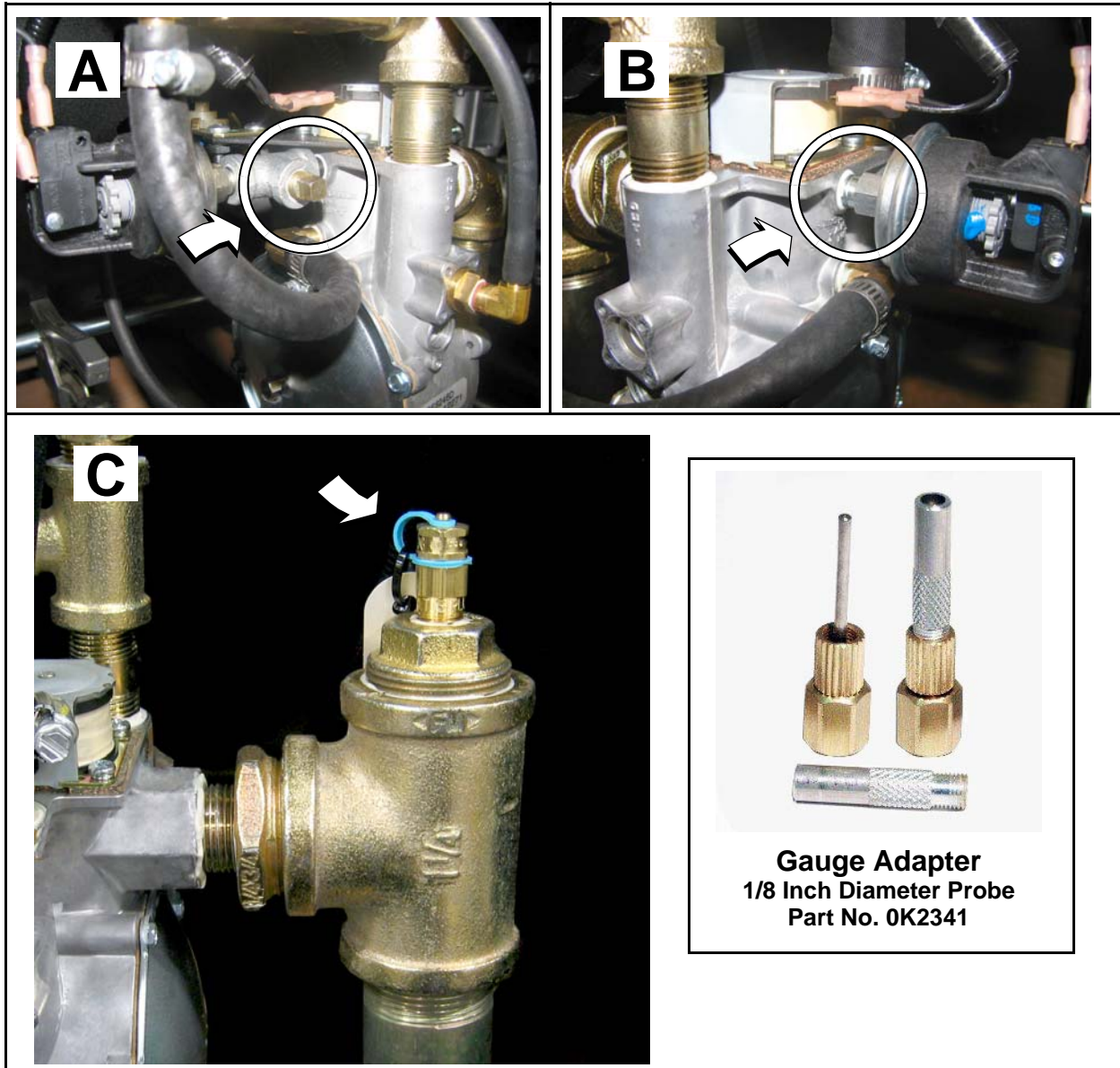

Figure 5-4. Fuel Pressure Test Points

5.6.2— Final Test Procedure

The following test must be performed at startup to document and validate fuel system operation. It requires a load bank connected to the unit, or a combination of load bank and system load, to bring the unit to its full rated kW load capacity.

Measure the fuel supply pressure under each of the following conditions:

1. **Static Pressure.** Pressure when the unit is not running. Must not exceed the maximum pressure listed in the unit specification sheet.

2. **Cranking Pressure.** Pressure when the unit is cranking. Must not drop more than 1 in. w.c. below *Static Pressure* or below the minimum pressure listed in the unit specification sheet. If it does, it may indicate that fuel supply piping is not correctly sized, or that primary regulator is improperly sized or mounted too close to the generator connection point. The unit may experience hard starting, or will not perform as expected at full load or during load transients.
3. **Running- No Load Pressure.** Pressure when the unit is running at rated frequency and voltage with no load. Should be at or slightly below the maximum pressure as listed in the unit specification sheet.
4. **Running- Full Load Pressure.** Pressure when the unit is running with full rated load applied (**kW**). Pressure should not drop more than 1-2 in. w.c. from the *Running- No Load Pressure* and must **NEVER** drop below the minimum pressure listed in the unit specification sheet.

Section 6 *Electrical System*

6.1 — General Information

All wiring must be properly sized, routed, supported, and connected. All wiring must comply with NEC and local codes. The generator uses Customer Connection Interface (CCI) panels to separate the high voltage and customer control wiring connections. These two panels are clearly labeled. The wiring diagrams for each specific unit show the connection points in their corresponding sections. Terminal boards are clearly labeled and correspond to the same terminal connections shown in the wiring diagrams. Always use the unit specific wiring diagrams when making wiring connections.

6.2 — Remove Rear Panel and Stub Up Cover

1. See Figure 6-1. Remove six screws with nylon washers to release rear panel from enclosure. For best results, rotate left side of panel outward away from enclosure before disengaging the right side.
2. Remove four screws with nylon washers to release fascia from control panel.
3. The stub up cover and five screws with flat washers are shipped loose and found inside the enclosure.

6.3 — Wiring Installation Safety

Review the safety rules at the beginning of this manual for specific dangers, cautions, and hazards associated with the installation of industrial products.

When installing the generator set and connecting wiring, keep the generator and system de-energized and disabled. It is common electrical safety practice to verify that wires are de-energized using appropriate safety gear and a meter before handling. Disable the generator by placing the AUTO/OFF/MANUAL switch in the OFF position, de-energize the battery charger, and disconnect the negative cable from the negative battery terminal. Also, make sure the auxiliary power circuit to the unit is de-energized.

6.4 — General Wiring Requirements

Consider the following general wiring requirements:

- Load Wiring - Properly size and select wiring.
- Control Wiring - Typically low DC voltage wiring (12 Vdc) that includes the 2-wire start and signal wiring. Use multi-strand wire appropriately sized for the length of run. Do not exceed #12 AWG when connecting to the customer connection terminals.
- Accessory Power Wiring - Provides power for optional user accessories (battery warmer and block heater). Size and select wiring using the appropriate tables in the NEC and per the connection requirements in the individual control panel wiring diagram.

6.5 — High Voltage Connections

The customer connection area on the left side of the control panel contains the terminals to connect all high voltage wiring. These connections are as follows:

- MLCB - E1, E2, E3 (if three-phase), and Neutral for customer load wiring. These wires run from the main line circuit breaker to the transfer switch. They supply generator power to the transfer switch and are marked for easy identification.

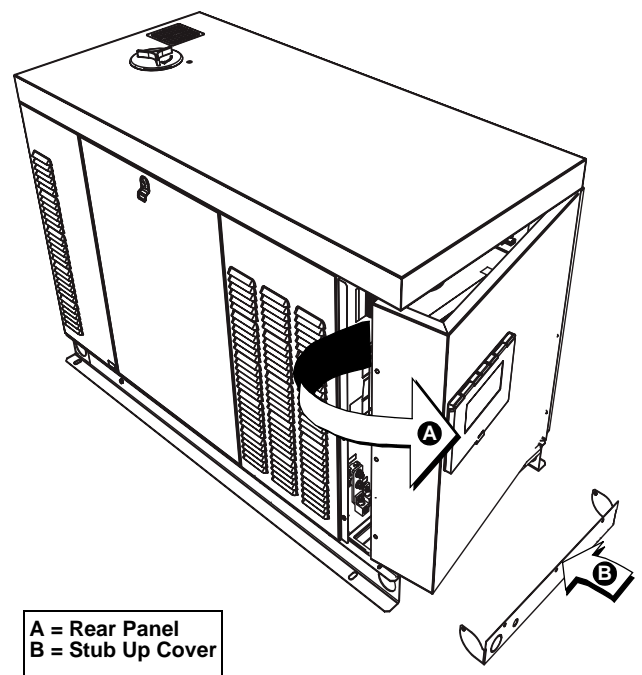

Figure 6-1. Remove Rear Panel and Stub Up Cover

NOTE: The following tables are provided for references purposes only. Refer to the latest NEC, state and local AHJ requirements for proper sizing of power and control wires.

Table 6-1. Frame Breakers

Frame Breaker	Range	Wire Type	Wire Temperature Rating	Lug AWG Range (Number of Conductors)	Torque to Wire
Generac 225 AF 2 Pole	125A-200A	Cu/Al	167° F (75° C)	6-350 kcmil (1)	375 in-lb
Generac 225 AF 3 Pole	50A-200A	Cu/Al	167° F (75° C)	6-350 kcmil (1)	375 in-lb
Generac 400 AF 2 Pole	225A-400A	Cu/Al	167° F (75° C)	1/0-250 kcmil (2) or 4-600 kcmil (1)	375 in-lb
Generac 400 AF 3 Pole	225A-400A	Cu/Al	167° F (75° C)	1/0-250 kcmil (2) or 4-600 kcmil (1)	375 in-lb

Table 6-2. Terminal Tightening Torques

Amperage Rating	Description	Cable Screw Torque	Wire Size Range
15-20 A	Load Side, Aluminum Body Lug	32 in-lb	#14 - #8 AWG Cu #12 - #8 AWG Al
25-35 A	Load Side, Aluminum Body Lug	36 in-lb	#8 - #6 AWG Cu #8 - #6 AWG Al
40-50 A	Load Side, Aluminum Body Lug	45 in-lb	#8 - #6 AWG Cu #8 - #4 AWG Al
55-70 A	Load Side, Aluminum Body Lug	50 in-lb	#8 - #4 AWG Cu #8 - #2 AWG Al
80-100 A	Load Side, Aluminum Body Lug	60 in-lb	#4 - #1/0 AWG Cu #2 - #1/0 AWG Al
10-130 A	Line Side, Threaded Contact With Ring Lugs	72 in-lb	#14 - #2 AWG

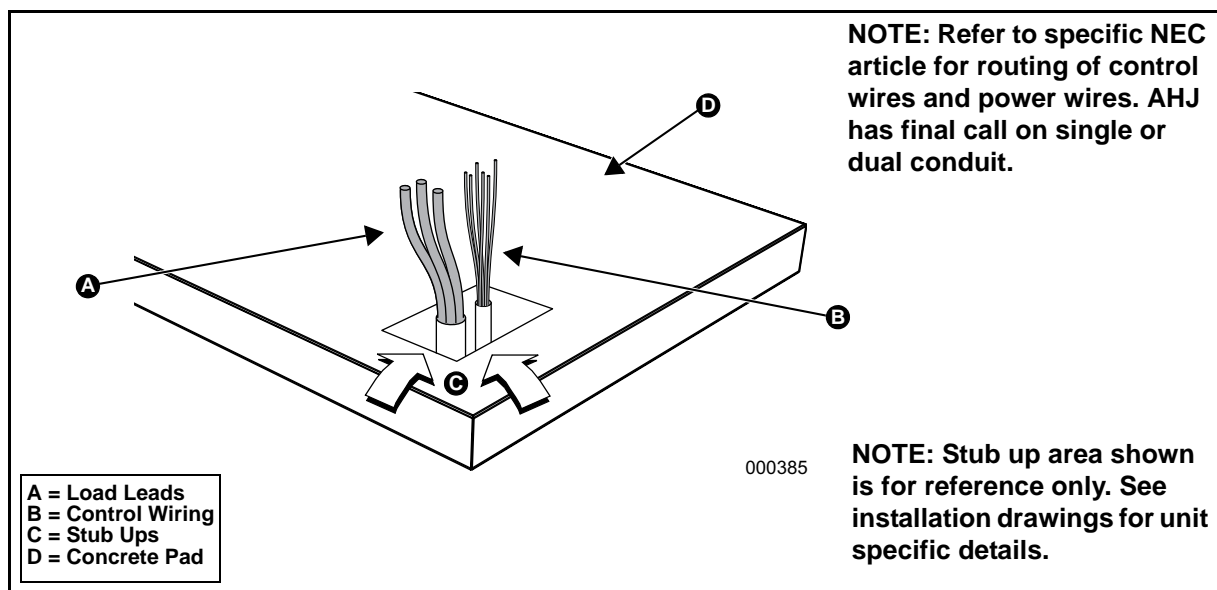

Figure 6-2. Typical Load Leads and Control Wiring in Stub Up

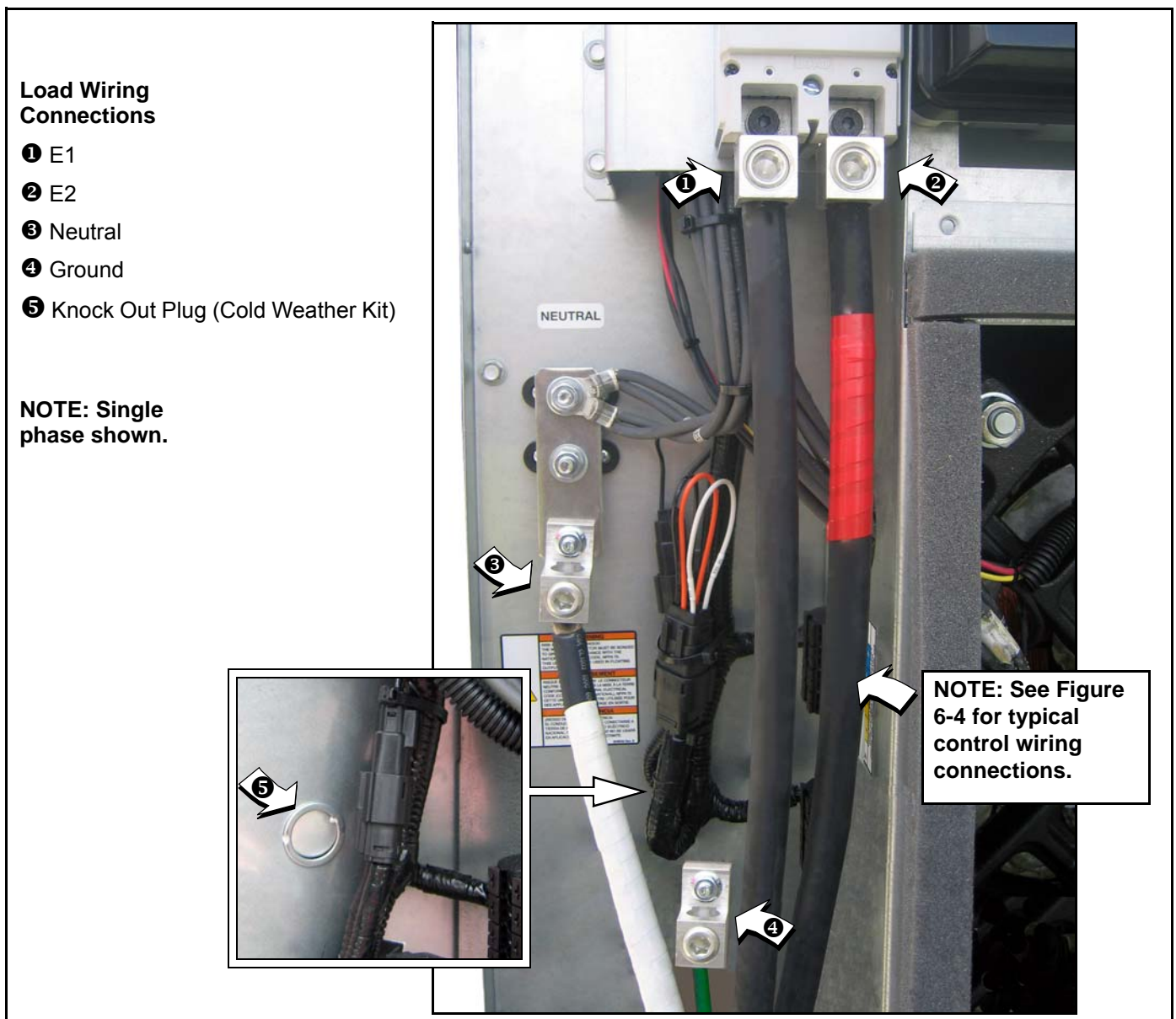

Figure 6-3. Typical High Voltage Connections

Customer load wiring consists of single-phase or three-phase connections between the generator Main Line Circuit Breaker (MLCB) and the transfer switch. The wiring connects to lugs E1, E2, E3 (if three phase on MLCB), neutral, and equipment ground at the generator and runs to the corresponding lugs in the transfer switch. All load wires, neutral and ground should be marked and terminated in the correct lugs in the transfer switch. Ensure all wiring is properly mounted and terminated at the appropriate connection points in both the generator and transfer switch. For general information regarding wire type, temperature rating, size range, and wire lug torque specifications, see Tables 6-1 and 6-2. Always refer to NEC tables for specific requirements.

NOTE: For three phase applications, use phase rotation meter to verify that the generator phase rotation matches the rotation of the utility.

NOTE: For three phase, delta configured alternators (voltage code J) the second leg (N2) must be bonded to all second legs in the entire system.

6.6 — Control Wiring Connections

The Control Wire Customer Connection block is where all of the control wiring is connected. Depending on the type of system, this wiring includes the following:

6.6.1— RTS Series Transfer Switch With T1 Fuse/Connection

NOTE: The control wire customer connections typically use Class 1 Wiring Methods (verify with AHJ). Always follow the standards and methods appropriate to the circuits being wired.

NOTE: T1 is the 120 VAC power supply for the control panel battery charger. This circuit must be powered whether the transfer switch is in utility or generator mode. If the circuit loses power the control board will generate a warning (Battery Charge AC Fail).

NOTE: Observe the maximum wire size for the terminal strip connections shown in the unit wiring diagram.

- ❶ For battery charging, connect neutral in TB2 to neutral in the transfer switch. See **NOTE** below for transfer switches without T1.
- ❷ Connect T1 in TB2 to T1 in the transfer switch. This is 120 volt supply to the unit's battery charger (normal RTS transfer switch).
- ❸ ❹ Connect N1, N2 sensing wires in TB2 to N1 and N2 in the transfer switch. These two wires are utility sensing wires.
- ❺ ❻ Connect 23 in TB3 to 23 in the transfer switch. Connect 194 in TB3 to 194 in the transfer switch. These are the transfer switch control wires.

TB2 Terminal Block				TB3 Terminal Block			
Terminal		Function	Voltages	Terminal		Function	Voltages
❶	Neutral	Neutral for T1 Battery Charger	Neutral		178	Two Wire Start Control [GTS]	5-12 VDC
❷	T1	Power for T1 Battery Charger	120 VAC		183	Two Wire Start Control [GTS]	5-12 VDC
❸	N2	Utility Sensing from Transfer Switch	208-277 VAC	❺	23	Transfer Relay Control Wire	12-0 VDC
❹	N1	Utility Sensing from Transfer Switch	208-277 VAC	❻	194	Power for Transfer Relay	12 VDC

Figure 6-4. Typical Control Wiring Connections

6.6.2— RTS Series Transfer Switch Without T1 Fuse/Connection

Use a 120 volt generator protected circuit from the panel board to power the battery charger circuit (dedicated 15/20 amp circuit).

6.6.3— Two-Wire Start

To convert transfer switches to 2 wire start mode of operation, see dealer for panel conversion and connection of terminals 178 and 183 in TB3. Use a 120 volt generator protected circuit from the panel board to power the battery charger circuit (dedicated 15/20 amp circuit).

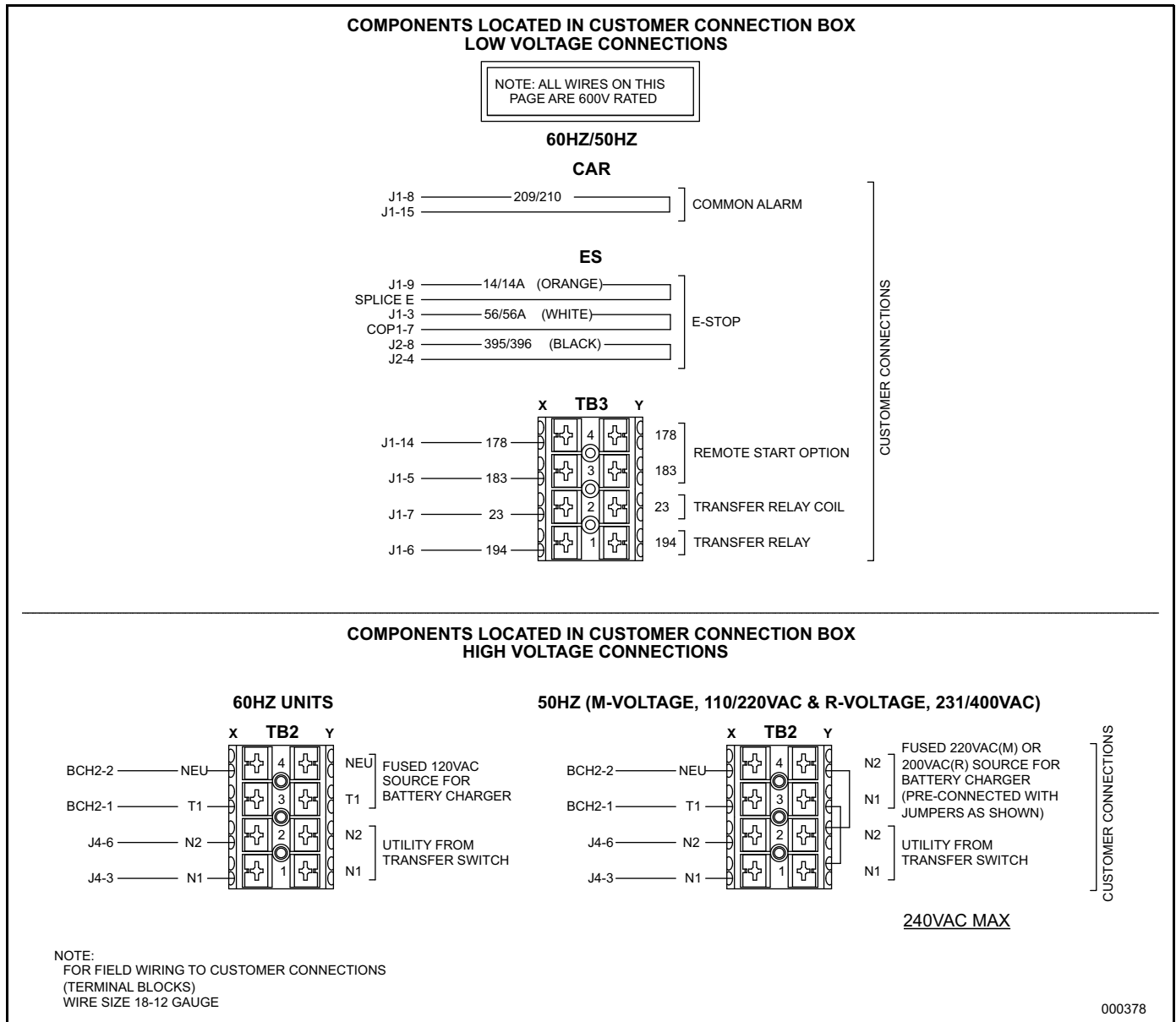

Figure 6-5. Typical Control Wiring Schematic

NOTE: The following table is provided for references purposes only. Refer to the latest NEC, state and local AHJ requirements for proper sizing.

Table 6-3. Control Wire Length/Size

Maximum Wire Length	Recommended Wire Size
1-115 ft (1-35m)	No. 18 AWG
116-185 ft (36-56m)	No. 16 AWG
186-295 ft (57-89m)	No. 14 AWG
296-460 ft (90-140m)	No. 12 AWG

6.7 — Optional Accessory Power

- Accessory power for optional items (battery warmer and block heater) should come from a customer utility supply source (with appropriate sized breaker), which is also powered by emergency power during an outage.
- Optional user installed GFCI receptacles. Provides a place to plug in optional battery warmer and block heater.

NOTE: Remove knock out plug and route accessory wiring to customer supplied weather-proof junction box. See Figure 6-3. Verify that wires do not contact moving or vibrating engine parts, as abraded wires can result in electrical problems.

6.8 — Install Stub Up Cover and Rear Panel

1. Install five screws with flat washers to secure stub up cover.
2. Install four screws with nylon washers to fasten fascia over control panel.
3. Install rear panel. For best results, first engage right side of panel and then rotate left side inward toward enclosure. Alternately work left and right sides in until slots are aligned with screw holes on both sides. Install six screws with nylon washers and tighten until snug.

6.9 — Transfer Switch Location

The location of the transfer switch is important. Consider the following:

1. Locate the transfer switch as close to the emergency load as practical to avoid interruptions of the emergency power system due to natural disasters or equipment failures.
2. Locate the transfer switch in a clean, dry, well ventilated location, away from excessive heat. Allow adequate working space around the transfer switch. Refer to the latest NEC, state and local AHJ requirements for details.
3. Install power and control wires as per NEC requirements. In a three phase system, all power conduits from the generator set must contain all three phases.
4. Conduit, wire, circuit protective device sizes, insulation etc. must conform to applicable local and national codes and regulations.

6.10 — Battery

6.10.1— General Cautions

⚠ DANGER!



Stationary emergency generators installed with automatic transfer switches will crank and start automatically when NORMAL (UTILITY) source voltage is removed or is below an acceptable preset level. To prevent automatic startup and possible injury to personnel, do not connect battery cables until NORMAL source voltage at the transfer switch is correct and the system is ready to be placed into operation.



Storage batteries give off **EXPLOSIVE** hydrogen gas. This gas can form an explosive mixture around the battery for several hours after charging. The slightest spark can ignite the gas and cause an explosion. An explosion can shatter the battery and cause blindness or other injury. Any area that houses a storage battery must be properly ventilated. Do not allow smoking, open flame, sparks, or any spark producing tools or equipment near the battery.



When working on the battery, always remove watches, rings, or other metal objects, and only use tools that have insulated handles. Do not lay tools or metal parts on top of the battery.



Discharge static electricity from the body before touching the battery by first touching a grounded metal surface.



Wear full eye protection, protective clothing, and gloves when handling a battery.



Battery electrolyte fluid is an extremely caustic sulfuric acid solution that can cause severe burns. Do not permit fluid to contact eyes, skin, clothing, painted surfaces, etc. Where electrolyte contacts the skin, wash it off immediately with water. If contact is with eyes, flush thoroughly and immediately with water and seek medical attention.

NOTE: Immediately wash down spilled electrolyte with an acid neutralizing agent. Use a solution of 1 pound (500 grams) bicarbonate of soda to 1 gallon (4 liters) of water. Add the bicarbonate of soda solution until evidence of reaction (foaming) has ceased. Flush the resulting liquid with water.

6.10.2— Battery Size

The ability to start the engine depends upon battery capacity, ambient temperatures and coolant and oil temperatures. The engine/generator set Data Sheet lists minimum recommended battery capacity at various ambient temperatures. The recommended battery capacities are listed under cold cranking amps (CCA) at 0 °F (-18 °C). Battery capacities decrease as ambient temperatures decrease, so it is important to specify batteries with the appropriate CCA rating at a temperature no higher than the minimum ambient temperature for the application.

6.10.3— Battery Installation

⚠ CAUTION!



Always connect the positive battery cable first. If the positive cable should contact ground with the negative cable installed, the resulting sparks may cause a battery explosion which could result in serious injury.

NOTE: Use appropriate tools when working with battery terminals. The use of terminal pullers, expansion pliers and terminal cleaning brushes will greatly extend the life of the battery terminals.

1. Install rubber protective cover over battery positive (+) terminal. See A of Figure 6-6.
2. Grasp battery strap and lift battery. See B of Figure 6-6.
3. Set battery onto battery tray.
4. Tighten two screws with nylon washers to secure hold-down clamp to battery tray.
5. Remove rubber protective cover from battery positive (+) terminal.
6. Install battery positive cable (red) to battery positive (+) terminal.
7. Install battery negative cable (black) to battery negative (-) terminal.

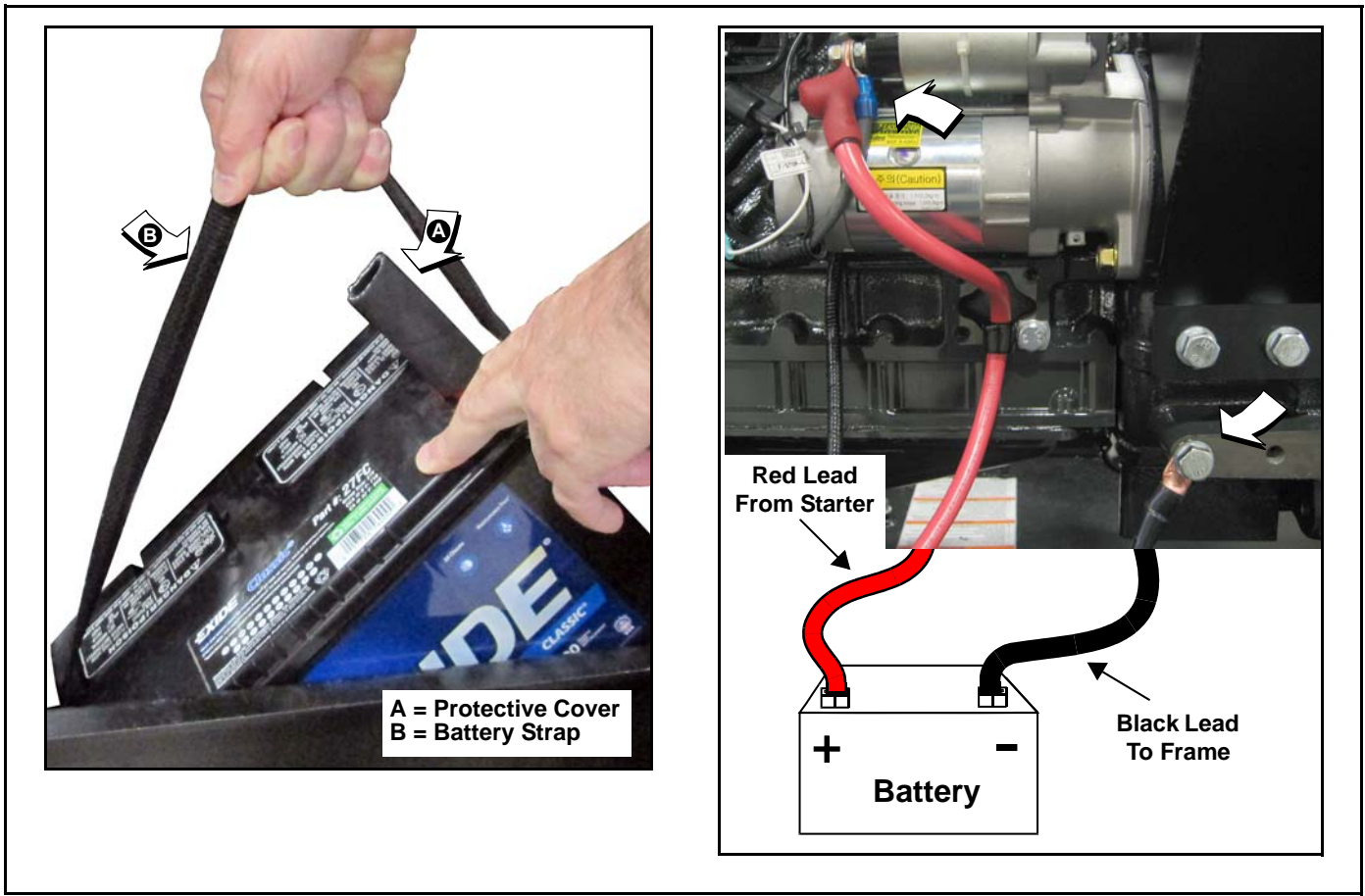
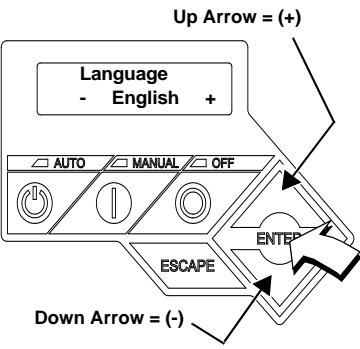

Figure 6-6.

6.11 — Activate Unit

<p>Display Reads:</p>  <p>Up Arrow = (+)</p> <p>Down Arrow = (-)</p>	<p>Generator Active is displayed on the LCD screen when the unit is first powered up. After displaying firmware and hardware version codes, as well as other system information, the Installation Wizard is launched, and the Language screen is displayed.</p> <p>Use UP ARROW or DOWN ARROW to scroll to desired language.</p> <p>Press ENTER.</p>	<p>If the wrong language is selected, it may be changed later using the Edit menu.</p>
<p>Display Reads:</p> <div style="border: 1px solid black; padding: 5px; text-align: center;"> <p>Activate me (ENT) or ESC to run in manual</p> </div>	<p>Press ENTER.</p>	<p>Press ESCAPE to abort the activation sequence. NOT ACTIVATED is displayed and the generator will run in manual mode only. Disconnect and reconnect the negative battery cable to restart the activation routine. If power is removed after a successful activation, no data is lost, but the time and date must be updated.</p>
<p>Display Reads:</p> <div style="border: 1px solid black; padding: 5px; text-align: center;"> <p>To Activate go to www.activategen.com</p> </div>	<p>Go to www.activategen.com or call 1-888-9ACTIVATE (922-8482, US & Canada only) if activation passcode is not available.</p> <p>If activation pass code is available, wait a few seconds for the next display.</p>	
<p>Display Reads:</p> <div style="border: 1px solid black; padding: 5px; text-align: center;"> <p>SN 1234567890 PASS CODE XXXXX</p> </div>	<p>Use UP ARROW or DOWN ARROW to increment or decrement the digit to correspond to the first number of the pass code.</p> <p>Press ENTER.</p> <p>Repeat step to enter remaining digits.</p>	<p>Press ESCAPE to return to preceding digits if a correction becomes necessary.</p> <p>If attempts to enter the activation code are unsuccessful, check the number against the code given on activategen.com. If it is correct, contact 1-888-9ACTIVATE (922-8482, US & Canada only).</p>
<p>Display Reads:</p> <div style="border: 1px solid black; padding: 5px; text-align: center;"> <p>Select Hour (0-23) - 6 +</p> </div>	<p>Use UP ARROW or DOWN ARROW to increment or decrement the hour. Press ENTER.</p> <p>Use UP ARROW or DOWN ARROW to increment or decrement the minute. Press ENTER.</p> <p>Use UP ARROW or DOWN ARROW to select the month. Press ENTER.</p> <p>Use UP ARROW or DOWN ARROW to increment or decrement the date. Press ENTER.</p> <p>Use UP ARROW or DOWN ARROW to increment or decrement the year. Press ENTER.</p>	

<p>Display Reads:</p> <div style="border: 1px solid black; padding: 10px; text-align: center;"> <p>Quiet Test Mode? Yes No</p> </div>	<p>Use UP ARROW or DOWN ARROW to select either Yes or No.</p> <p>Press ENTER.</p>	<p>Select YES to perform exercise at low speed. Select NO to perform exercise at normal operating speed.</p>
<p>Display Reads:</p> <div style="border: 1px solid black; padding: 10px; text-align: center;"> <p>Select Hour (0-23) - 1 +</p> </div>	<p>Set Exercise Time.</p> <p>Use UP ARROW or DOWN ARROW to increment or decrement the hour. Press ENTER.</p> <p>Use UP ARROW or DOWN ARROW to increment or decrement the minute. Press ENTER.</p> <p>Use UP ARROW or DOWN ARROW to scroll to the day of the week. Press ENTER.</p>	<p>In the AUTO mode, the engine starts and runs once each week at the time and day specified. During the exercise cycle, the unit runs approximately 12 minutes and then shuts down. Transfer of loads to the generator does not occur unless utility power fails.</p>

6.12 — Operational Checks

NOTE: The following procedures require special tools and skills. Contact a Generac Dealer or an authorized service provider to perform these tasks.

6.12.1— Self Test

Upon power up, the controller goes through a system self test which checks for the presence of utility voltage on the DC circuits. This is done to prevent damage if the installer mistakenly connects AC utility power sense wires into the DC terminal block. If utility voltage is detected, the controller displays a warning message and locks out the generator, thereby preventing damage to the controller. Remove power to the controller to clear this warning.

Utility voltage must be turned on and present at the N1 and N2 terminals inside the generator control panel for this test to be performed and pass.

Before starting, complete the following:

1. Verify that the generator is OFF. A red LED above OFF on the control panel keypad illuminates to confirm that the system is in the OFF mode.
2. Verify that the Main Circuit Breaker switch on the generator control panel is in the OFF (Open) position.
3. Turn off all circuit breakers/electrical loads that will be powered by the generator.
4. Check the engine crankcase oil level, coolant level, and fuel level, if necessary.

During initial start up only, the generator may exceed the normal number of start attempts and experience an “over crank” fault. This is due to accumulated air in the fuel system during installation. Reset the control board and restart up to two more times, if necessary. If unit fails to start, contact the local dealer for assistance.

6.12.2— Check Manual Transfer Switch Operation

Refer to the “Manual Transfer Operation” section of the owner’s manual for procedures.

NOTE: Also use the appropriate transfer switch owner’s manual for manual and automatic system test.

⚠ DANGER!



Do not attempt manual transfer switch operation until all power voltage supplies to the transfer switch have been positively turned off. Failure to turn off all power voltage supplies will result in extremely hazardous and possibly fatal electrical shock.

6.12.3— Electrical Checks

NOTE: Verify that all power and control wiring is properly terminated in the generator and corresponding location in transfer switch. For three phase applications, verify that generator phase rotation matches utility phase rotation.

Complete electrical checks as follows:

1. Verify that the generator is OFF. A red LED above OFF on the control panel keypad illuminates to confirm that the system is in the OFF mode.
2. Verify that the Main Circuit Breaker switch on the generator control panel is in the OFF (Open) position.
3. Turn OFF all circuit breakers/electrical loads that will be powered by the generator.
4. Turn on the utility power supply to the transfer switch using the means provided (such as a utility main line circuit breaker).

⚠ DANGER!



The transfer switch is now electrically “hot.” Contact with “hot” parts will result in extremely hazardous and possibly fatal electrical shock.

5. Use an accurate AC voltmeter to check utility power source voltage across transfer switch terminals N1, N2, and N3 (if three phase). Normal line-to-line voltage should be equivalent to rated unit voltage.
6. Check utility power source voltage across terminals N1, N2, and N3 (if three phase) and the transfer switch neutral lug.
7. When certain that utility supply voltage is compatible with transfer switch and load circuit ratings, turn OFF the utility power supply to the transfer switch.
8. Press MANUAL on the control panel keypad to crank and start the engine.
9. Allow the engine to warm up for about five minutes. Move the Main Circuit Breaker switch on the generator control panel up to the ON (Closed) position.

⚠ DANGER!



Generator power voltage is now supplied to the transfer switch. Contact with live transfer switch parts will result in dangerous and possibly fatal electrical shock.

10. Connect an accurate AC voltmeter and a frequency meter across transfer switch terminal lugs E1, E2, and E3 (if three phase).
11. Successively connect the AC voltmeter test leads across terminal lugs E1, E2, and E3 (if three phase) and neutral. Voltage reading in each case should match utility voltage reading. If system is three phase, verify that generator phase rotation matches utility phase rotation.
12. Move the Main Circuit Breaker switch on the generator control panel down to the OFF (Open) position.
13. Press OFF on the control panel keypad to shut the engine down.

⚠ DANGER!



Do not proceed unless certain that generator AC voltage and frequency are correct and within the stated limits.

6.12.4— Test Generator Under Load

To test the generator set with electrical loads applied, proceed as follows:

1. Verify that the generator is OFF. A red LED above OFF on the control panel keypad illuminates to confirm that the system is in the OFF mode.
2. Turn OFF all breakers/electrical loads that will be powered by the generator.
3. Turn OFF the utility power supply to the transfer switch, using the means provided (such as a utility main line circuit breaker).

⚠ DANGER!



Do not attempt manual transfer switch operation until all power voltage supplies to the transfer switch have been positively turned off. Failure to turn off all power voltage supplies will result in extremely hazardous and possibly fatal electrical shock.

4. Manually set the transfer switch to the STANDBY position, i.e., load terminals connected to the generator’s E1, E2, and E3 (if three phase) terminals. The transfer switch operating lever should be down.

5. Press MANUAL on the control panel keypad. The engine should crank and start immediately.
6. Allow the engine to warm up for a few minutes.
7. Move the Main Circuit Breaker switch on the generator control panel up to the ON (Closed) position. Loads are now powered by the standby generator.
8. Turn ON the circuit breaker/electrical loads powered by the generator.
9. Connect a calibrated AC voltmeter and a frequency meter across terminal lugs E1, E2, and E3 (if three phase). Voltage should be approximately unit rated voltage.
10. Let the generator run at full rated load for 20-30 minutes. Listen for unusual noises, vibration or other indications of abnormal operation. Check for oil leaks, evidence of overheating, etc.
11. When testing under load is complete, turn OFF electrical loads.
12. Move the Main Circuit Breaker switch on the generator control panel down to the OFF (Open) position.
13. Allow the engine to run at no-load for 2-5 minutes.
14. Press OFF on the control panel keypad to shut the engine down.

6.12.5— Check Automatic Operation

To check the system for proper automatic operation, proceed as follows:

1. Verify that the generator is OFF. A red LED above OFF on the control panel keypad illuminates to confirm that the system is in the OFF mode.
2. Install front cover over the transfer switch.
3. Turn ON the utility power supply to the transfer switch, using the means provided (such as a utility main line circuit breaker).

NOTE: Transfer Switch will transfer back to utility position.

4. Move the Main Circuit Breaker switch on the generator control panel up to the ON (Closed) position.
5. Press AUTO on the control panel keypad. The system is now ready for automatic operation.
6. Turn OFF the utility power supply to the transfer switch.

With the generator ready for automatic operation, the engine will crank and start when the utility source power is turned OFF after a 10 second delay (factory default setting). After starting, the transfer switch connects load circuits to the standby side. Let the system operate through its entire automatic sequence of operation.

With the generator running and loads powered by generator AC output, turn ON the utility power supply to the transfer switch. The system transfers back to the utility position and then runs through the cool down cycle and shuts down.

6.13 — Installation Summary

1. Ensure that the installation has been properly performed as outlined by the manufacturer and that it meets all applicable laws and codes.
2. Test and confirm proper operation of the system as outlined in the appropriate installation and owner's manuals.
3. Educate the customer on the proper operation, maintenance and service call procedures.

IMPORTANT! If the customer ever finds it necessary to turn the generator off during prolonged utility outages to conserve fuel or perform maintenance, alert them to these important steps:

To turn the generator OFF (while running in AUTO and online):

1. Turn OFF (or open) the main Utility disconnect.
2. Move the Main Circuit Breaker switch on the generator control panel down to the OFF (Open) position.
3. Press OFF on the control panel keypad. A red LED illuminates to confirm that the system is in the OFF mode.

To turn the generator back ON:

1. Press AUTO on the control panel keypad. Allow the unit to start and warm up for a few minutes.
2. Move the Main Circuit Breaker switch on the generator control panel up to the ON (Closed) position.

The system is now operating in the automatic mode. The main utility disconnect can be turned ON (Closed), but to shut the unit off, this complete process must be repeated.

Section 7 Lube Oil Maintainer System

7.1 — Lube Oil Maintainer System

7.1.1— Description

NOTE: Oil reservoir is empty when shipped from factory. Fill with clean engine oil to activate the system.

Oil reservoir capacity: 2.5 gallons (9.46 liters)

The 36 kW, 45 kW, and 60 kW models are equipped with a Lube Oil Maintainer System. The system is installed at the factory and calibrated at the factory to the correct engine-running crankcase oil level. As needed, the system keeps the engine lubricating oil full by automatically adding clean oil from the oil supply tank.

See A of Figure 7-1 The green bar observed through the viewing lens shows the normal oil level operating range of the Lube Oil Maintainer Regulator during engine running operation. When the oil level is within the green bar, the internal float holds the inlet valve closed to keep the crankcase oil at the current level.

As the engine uses oil, the float drops to open the inlet valve and allow clean oil to be supplied to the crankcase, replenishing engine oil to the full mark indicated on the oil dipstick. The float then rises with the crankcase oil level until it reaches a point where the inlet valve closes.

When the oil level as observed through the viewing lens is below the normal operating range green bar, it is an indication that the oil supply tank is low or the oil inlet screen is clogged. See B of Figure 7-1

NOTE: It is normal for the oil level to be above the normal operating range green bar when engine is not running.

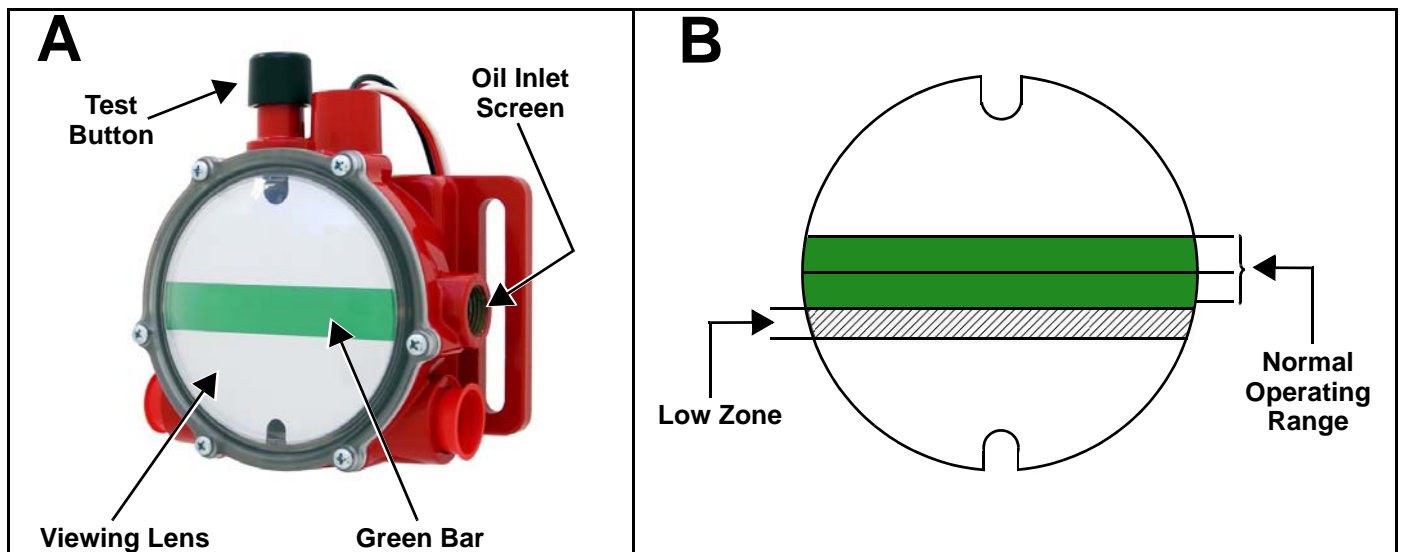

Figure 7-1. Lube Oil Maintainer Regulator

NOTE: When changing engine oil, always close the shutoff valve to avoid draining the clean oil in the oil supply tank with the crankcase oil. See Figure 7-3

7.1.2— Fill Oil Supply Tank

1. Rotate plastic cover counter-clockwise and remove from top of enclosure. See Figure 7-2
2. Remove fill cap at top of oil supply tank (Figure 7-2).
3. Add clean engine oil to oil supply tank (2-1/2 gallons [9.46 liters] capacity).
4. Install fill cap at top of oil supply tank.
5. Install plastic cover at top of enclosure and rotate clockwise until tight.

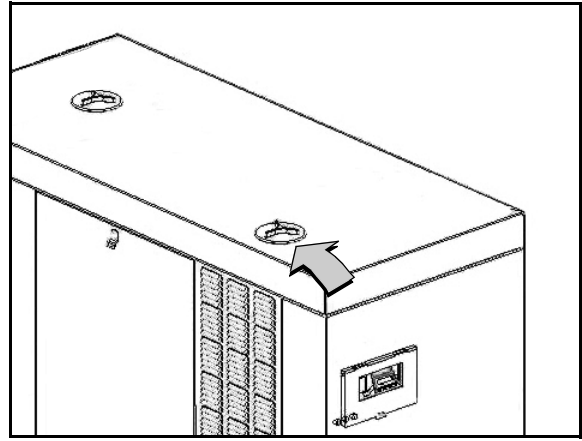

Figure 7-2. Access Oil Supply Tank

7.1.3— Test Functionality

See A of Figure 7-1 Momentarily press the test button to confirm that the float is operating correctly.

▲ CAUTION!



Do not hold the test button down for a prolonged period of time or the crankcase can be over filled. Over filling the crankcase can result in engine damage.

7.1.4— Shutoff Valve

See Figure 7-3 and Figure 7-4 When draining engine crankcase oil, always close shutoff valve to avoid draining clean oil from supply tank.

After filling crankcase with clean oil, remember to open shutoff valve to enable operation of Lube Oil Maintainer System.

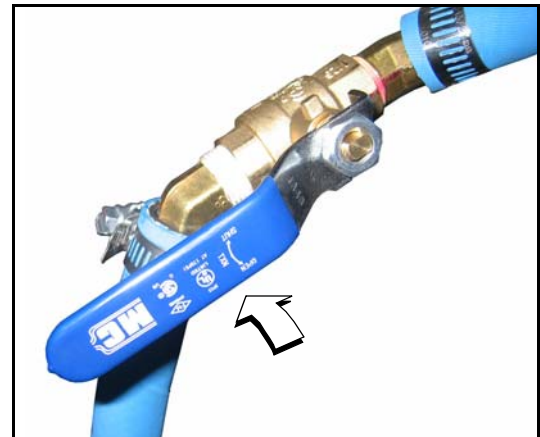

Figure 7-3. Shutoff Valve (Shown in Open Position)

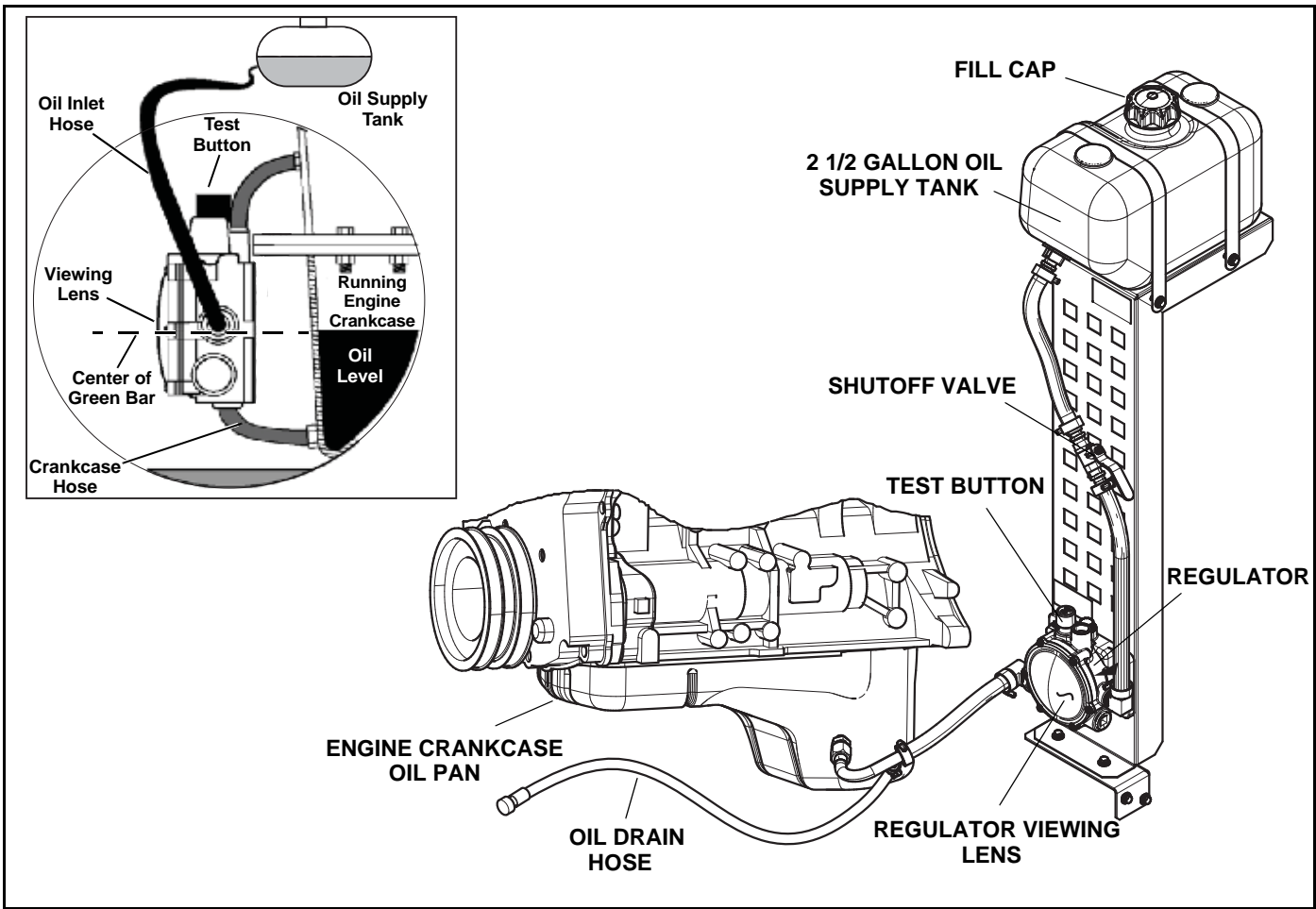

Figure 7-4. Lube Oil Maintainer Assembly and Function Diagram

This page intentionally left blank.

Section 8 *Installation Checklists*

8.1 — Safety Checklist

NOTE: See Chapter 1 for more information.

- Are manuals, wiring diagrams and other documentation readily available?
- Is there any evidence of freight damage?
- Does the enclosure have scratches or damage to painted surfaces (which would indicate lifting without a spreader bar)?
- Are all guards, covers, insulation blankets and other protective devices in place?
- Are any parts or components worn, damaged or missing?
- Is the generator properly grounded?
- Is a fire extinguisher kept near the generator?
- Is there any evidence of oil or coolant leaks?
- Are any combustible materials left in the generator compartment?
- Is the area surrounding the generator clean and free of debris?
- Do these parameters meet all applicable codes and local jurisdiction?

8.2 — Installation Planning Checklist

NOTE: See Chapter 2 for more information.

- Is the generator set readily accessible for maintenance, repair, and firefighting purposes?
- Is the site clean and dry? Is the site provided with adequate drainage?
- Is there a minimum of five feet of clearance around the generator set to facilitate the repair or replacement of major components?
- Have adequate provisions been made for installation of the fuel supply?
- Do these parameters meet all applicable codes and local jurisdiction?

8.3 — Foundations and Mounting Checklist

NOTE: See Chapter 3 for more information.

- Is the generator set installed on a concrete pad capable of supporting its weight and accessories?
- Is the generator securely fastened to the concrete pad using suitable grade, size and style fasteners?
- Is the concrete pad seated on a prepared solid subsurface using appropriate reinforcing bar or expanded wire mesh?

- Does the concrete pad extend beyond the frame rails at least six (6) inches (15.24 cm) on all sides?
- Is the concrete pad flat and level to within 1/2 inch?
- Are plugs installed in the tie-down holes of the frame rail?
- If installed on a roof or combustible floor, is the generator seated on a layer of sheet metal and non-combustible insulation? Do the sheet metal and insulation extend beyond the generator base at least six (6) inches (15.24 cm) on all sides?
- Is the base frame stub-up cover plate installed?
- Do all fuel, coolant, exhaust, and electrical lines have flexible sections where they connect to the generator?
- Is all piping properly supported and secured?
- Do these parameters meet all applicable codes and local jurisdiction?

8.4 — Ventilation System Checklist

NOTE: See Chapter 4 for more information.

- Is there sufficient air flow for cooling and ventilation?
- Are all bushes, shrubs and other vegetation a minimum of 3 feet away?
- Does the air inlet face the direction of prevailing winds?
- Has system piping been properly sized? Have all gas loads been taken into consideration?
- Has system been properly protected from freeze up and corrosion?
- Have standby equipment heaters been specified?
- Have system drain valves and air eliminators been installed?
- Does the air outlet face noise sensitive areas without noise attenuating devices?
- Does the installation appear to have the necessary accessories to enable fast, reliable starting and operation in adverse weather conditions (such as engine block heaters, battery warmers, etc.)?
- Do these parameters meet all applicable codes and local jurisdiction?

8.5 — Exhaust System Checklist

NOTE: See Chapter 5 for more information.

- Are exhaust discharges directed away from combustible surfaces and inhabited areas?
- Is exhaust piping kept clear of fuel supply, fuel lines, etc.?
- Is off-engine exhaust piping covered with high temperature insulation blankets where necessary?
- Do these parameters meet all applicable codes and local jurisdiction?

8.6 — Gaseous Fuel System Checklist

NOTE: See Chapter 5 for more information.

- Are fuel supply lines properly sized and installed? Were fuel supply lines purged and leak tested?
- Are sediment traps and drip legs installed to remove water and condensate from the gas flow?
- Is the fuel pressure regulator properly sized?
- Is a pressure test port installed before the fuel shutoff solenoids at the inlet to the unit mounted regulator?
- Does the generator have a dedicated fuel line which is not shared with any other appliances?
- Is the regulator sized to have a fuel flow delivery rating (CFH) at least 10% greater than the 100% rated kW fuel consumption requirement of the generator?
- Is the fuel pressure regulator approved for a mechanized engine application?
- Does the fuel pressure regulator have an accuracy rating of 1% or less and/or have a maximum allowable pressure drop of 1-2 inches w.c. under all operating conditions, that is, static, cranking, running at no load, and running at full load (as measured at the primary fuel pressure regulator)?
- Does the fuel pressure regulator have a spring rating of 5-14 inches w.c.?
- Does the system use black iron piping or other approved gas line?
- Is the gas line rigidly mounted and protected against vibration?
- Is a length of flexible hose installed between the generator connection point and the rigid supply piping? Is the flexible hose straight without bends, twists or kinks?
- Is the piping correctly sized to maintain the required supply pressure and volume under varying load conditions?
- Was an approved pipe sealant or joint compound used on all threaded fittings?
- Is a fuel shutoff valve installed near the unit? Was proper operation of the fuel shutoff valve verified?
- Was the Final Operating Test performed to verify that the system operates correctly in all modes of operation?
- Is there any evidence of leakage at any hoses, clamps or fittings?
- Do these parameters meet all applicable codes and local jurisdiction?

8.7 — Electrical System Checklist

NOTE: See Chapter 6 for more information.

- Is all wiring correctly sized for load and length of run?
- Is all wiring correctly routed?
- Is all wiring correctly connected?
- Are wire lugs fastened to buss bars using appropriate hardware? Is hardware properly tightened to specified torque?
- Are all other terminals correctly tightened using the specified torque?
- Are batteries correctly sized?

- Are batteries correctly installed?
- Are the battery fluid levels correct?
- Are battery cables and connections clean and free of corrosion?
- Are the battery cables correctly connected? Are the terminal lugs correctly tightened?
- Is the battery condition and state of charge acceptable?
- Is area housing storage battery properly ventilated?
- Are batteries located near a source of flame or spark?
- Are AC wire sizes and connections correct?
- Are DC and communication wire sizes and connections correct?
- Are DC and communication wires routed separately from AC wires (per code)?
- Are block heaters, battery charger, etc. properly matched with utility supply voltage?
- Are battery charger and block heater properly connected?
- Are remote start Wires 178 & 183 pulled and connected inside lower control panel of generator and inside transfer switch?
- Is the AUTO/OFF/MANUAL mode in the "OFF" position?
- Is the block heater operational?
- Is the battery charger operational?
- Are all AC electrical connections tight at the circuit breaker and transfer switch?
- Are all electrical connections (wiring, wire ties, clamps, terminal ends, connectors) on the generator tight?
- Are all electrical plugs throughout the generator seated correctly and fully inserted into their receptacles?
- Is there proper voltage and phase rotation at the transfer switch?
- Is manual operation of the transfer switch smooth and non-binding?
- Do these parameters meet all applicable codes and local jurisdiction?

8.8 — Oil Maintainer System Checklist

NOTE: See Section 7 for more information.

- Has the oil maintainer oil supply tank been filled with the recommended engine oil and tested?
- Has the oil maintainer been tested to the proper level?

Section 9 Installation Drawings

9.1 — 0K8420-A 25/30 kW (1.5 L) Page 1 of 2

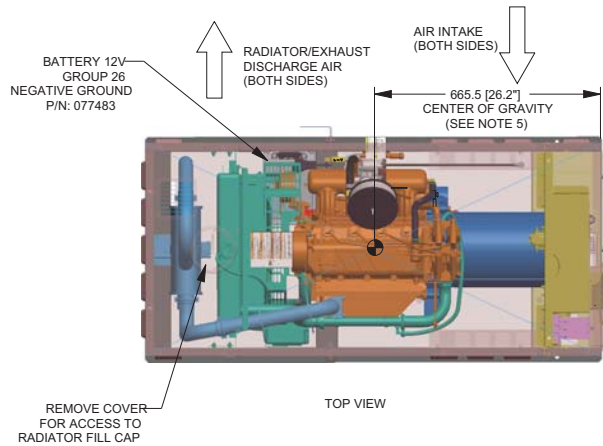

SERVICE ITEM	1.5L
OIL FILL CAP	EITHER DOOR
OIL DIP STICK	RIGHT DOOR
OIL FILTER	RIGHT DOOR
OIL DRAIN HOSE	RIGHT DOOR
RADIATOR DRAIN HOSE	RIGHT DOOR
AIR CLEANER ELEMENT	RIGHT DOOR
SPARK PLUGS	RIGHT DOOR
MUFFLER	SEE NOTE 12
FAN BELT	EITHER DOOR
BATTERY	RIGHT DOOR

REFERENCE OWNERS MANUAL FOR PERIODIC REPLACEMENT PART LISTINGS.

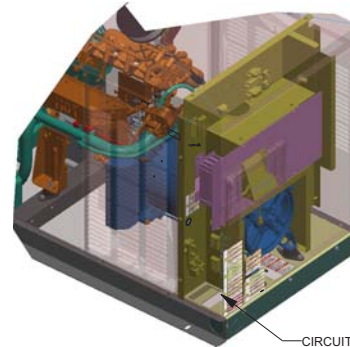

NOTES:

- MINIMUM RECOMMENDED CONCRETE PAD SIZE: 1092 (43") WIDE X 1887 (74.3") LONG. REFERENCE INSTALLATION GUIDE SUPPLIED WITH UNIT FOR CONCRETE PAD GUIDELINES.
- ALLOW SUFFICIENT ROOM ON ALL SIDES OF THE GENERATOR FOR MAINTENANCE AND SERVICING. THIS UNIT MUST BE INSTALLED IN ACCORDANCE WITH CURRENT APPLICABLE NFPA 37 AND NFPA 70 STANDARDS AS WELL AS ANY OTHER FEDERAL, STATE, AND LOCAL CODES.
- CONTROL PANEL / CIRCUIT BREAKER INFORMATION:
 - SEE SPECIFICATION SHEET OR OWNERS MANUAL
 - ACCESSIBLE THROUGH CUSTOMER ACCESS ASSEMBLY DOOR ON REAR OF GENERATOR.
- REMOVE THE REAR ENCLOSURE COVER PANEL TO ACCESS THE STUB-UP AREAS AS FOLLOWS:
 - HIGH VOLTAGE CONNECTION INCLUDING AC LOAD LEAD CONDUIT CONNECTION NEUTRAL CONNECTION, BATTERY CHARGER 120 VOLT AC (0.5 AMP MAX) CONNECTION.
 - LOW VOLTAGE CONNECTION INCLUDING TRANSFER SWITCH CONTROL WIRES.
- CENTER OF GRAVITY AND WEIGHT MAY CHANGE DUE TO UNIT OPTIONS.
- BOTTOM OF GENERATOR SET MUST BE ENCLOSED TO PREVENT PEST INTRUSION AND RECIRCULATION OF DISCHARGE AIR AND/OR IMPROPER COOLING AIR FLOW.
- EXHAUST SYSTEM MAXIMUM BACK PRESSURE: 24 INCHES H₂O.
- REFERENCE OWNERS MANUAL FOR LIFTING WARNINGS.
- MOUNTING BOLTS OR STUDS TO MOUNTING SURFACE SHALL BE 5/8-11 GRADE 5 (USE STANDARD SAE TORQUE SPECS)
- MUST ALLOW FREE FLOW OF INTAKE AIR, DISCHARGE AIR AND EXHAUST. SEE SPEC SHEET FOR MINIMUM AIR FLOW AND MAXIMUM RESTRICTION REQUIREMENTS.
- GENERATOR MUST BE INSTALLED SUCH THAT FRESH COOLING AIR IS AVAILABLE AND THAT DISCHARGE AIR FROM RADIATOR IS NOT RECIRCULATED.
- EXHAUST MUFFLER ENCLOSED WITHIN GENERATOR ENCLOSURE, REMOVE ENCLOSURE TO ACCESS EXHAUST MUFFLER.

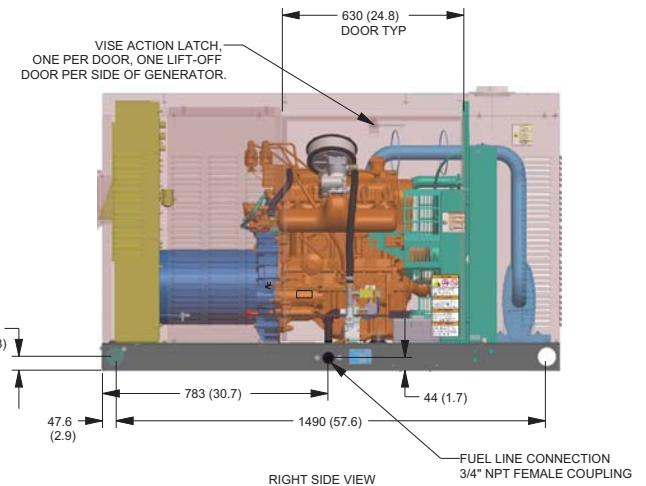
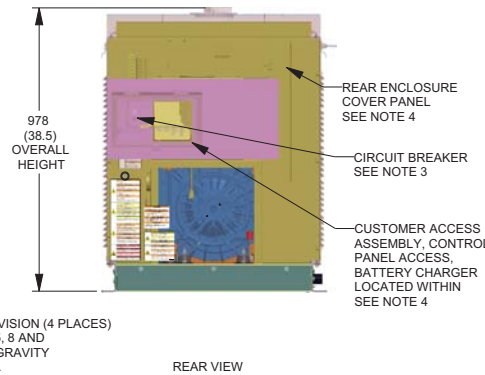
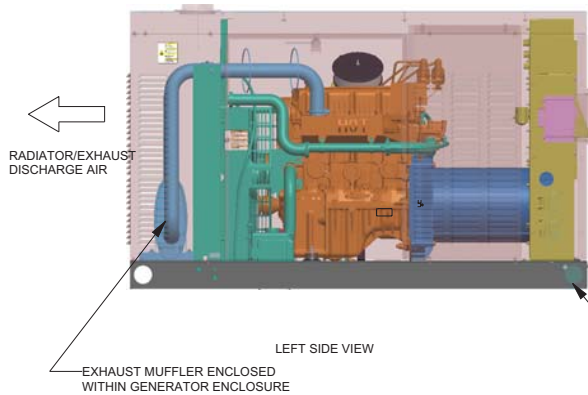

WEIGHT DATA				
ENGINE/KW	ENCLOSURE MATERIAL	WEIGHT GENSET ONLY KG [LBS]	WEIGHT SHIPPING SKID KG [LBS]	SHIPPING WEIGHT KG [LBS]
1.5L/25KW	ST	392 [865]	30 [66]	422 [931]
1.5L/30KW	ST	406 [895]	30 [66]	436 [961]
1.5L/25KW	AL	352 [777]	30 [66]	382 [843]
1.5L/30KW	AL	366 [807]	30 [66]	396 [873]

DIMENSIONS: MM [INCH]

0K8420-A 25/30 kW (1.5 L) Page 2 of 2

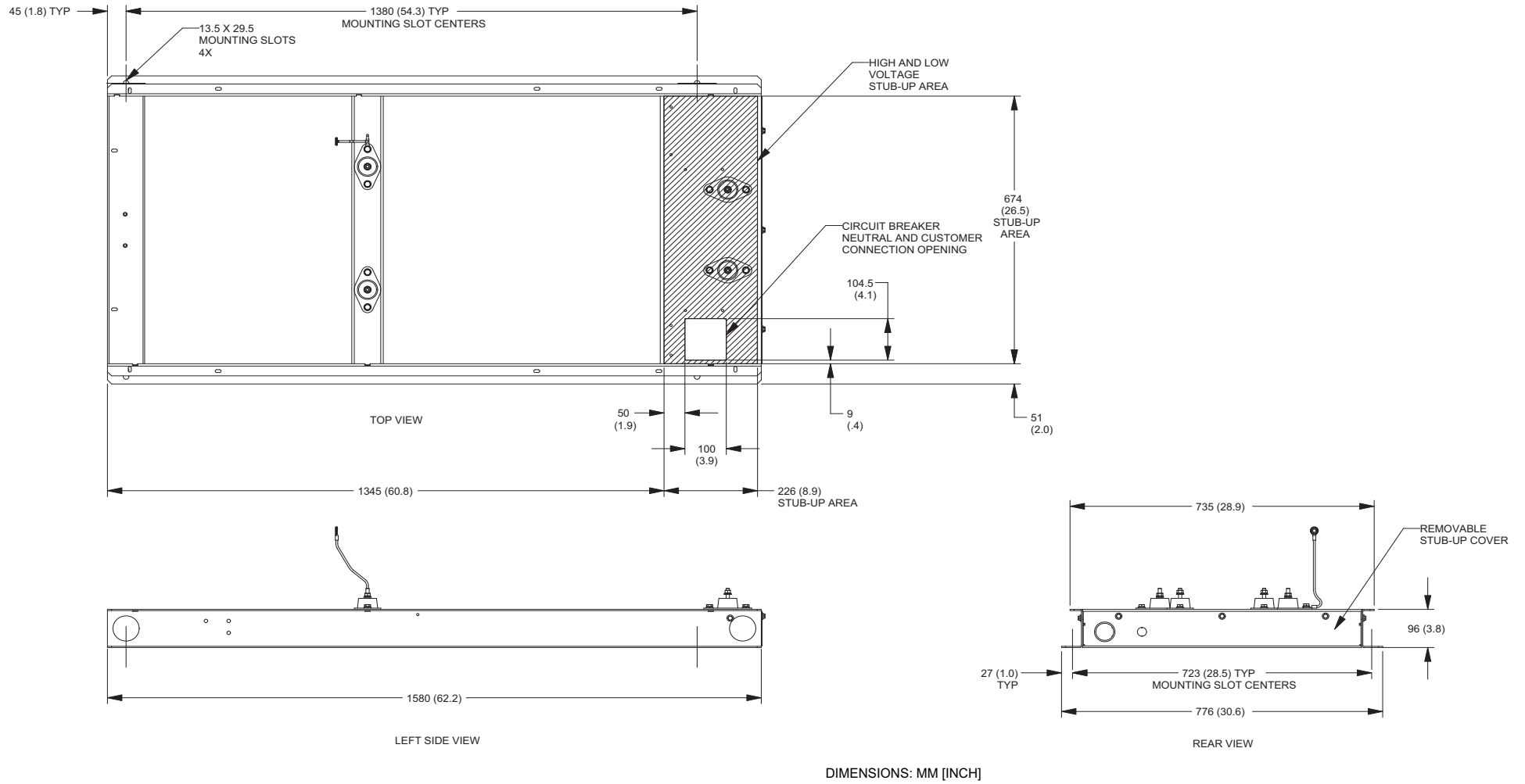

9.2 — 0K8624-A 22/27 kW (2.4 L) Page 1 of 2

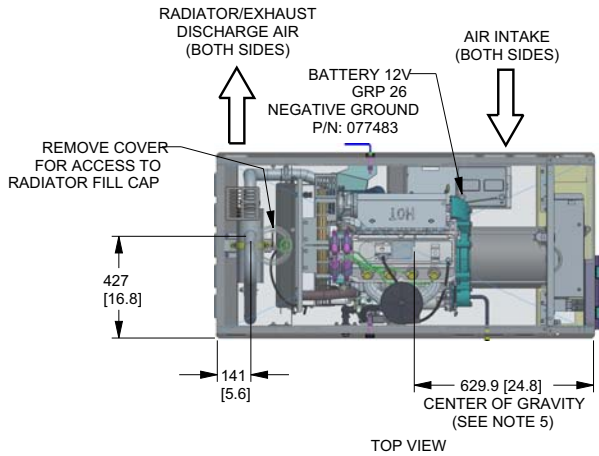

SERVICE ITEM	2.4L
OIL FILL CAP	EITHER SIDE
OIL DIP STICK	RIGHT SIDE
OIL FILTER	RIGHT SIDE
OIL DRAIN HOSE	LEFT SIDE
RADIATOR DRAIN	LEFT SIDE
COOLANT RECOVERY BOTTLE	LEFT SIDE
RADIATOR FILL CAP	ROOF TOP
AIR CLEANER ELEMENT	LEFT SIDE
SPARK PLUGS	LEFT SIDE
MUFFLER	SEE NOTE 11
DRIVE BELT	EITHER SIDE
FAN BELT	SEE NOTE 11
BATTERY	LEFT SIDE

REFERENCE OWNERS MANUAL FOR PERIODIC REPLACEMENT PART LISTINGS.

NOTES:

- MINIMUM RECOMMENDED CONCRETE PAD SIZE: 1092 (43") WIDE X 1885 (74.2") LONG. REFERENCE INSTALLATION GUIDE SUPPLIED WITH UNIT FOR CONCRETE PAD GUIDELINES.
- ALLOW SUFFICIENT ROOM ON ALL SIDES OF THE GENERATOR FOR MAINTENANCE AND SERVICING. THIS UNIT MUST BE INSTALLED IN ACCORDANCE WITH CURRENT APPLICABLE NFPA 37 AND NFPA 70 STANDARDS AS WELL AS ANY OTHER FEDERAL, STATE, AND LOCAL CODES.
- CONTROL PANEL / CIRCUIT BREAKER INFORMATION:
 - SEE SPECIFICATION SHEET OR OWNERS MANUAL
 - ACCESSIBLE THROUGH CUSTOMER ACCESS ASSEMBLY DOOR ON REAR OF GENERATOR.
- REMOVE THE REAR ENCLOSURE COVER PANEL TO ACCESS THE STUB-UP AREAS AS FOLLOWS:
 - HIGH VOLTAGE CONNECTION INCLUDING AC LOAD LEAD CONDUIT CONNECTION
 - NEUTRAL CONNECTION, BATTERY CHARGER 120 VOLT AC (0.5 AMP MAX) CONNECTION.
 - LOW VOLTAGE CONNECTION INCLUDING TRANSFER SWITCH CONTROL WIRES.
- CENTER OF GRAVITY AND WEIGHT MAY CHANGE DUE TO UNIT OPTIONS.
- BOTTOM OF GENERATOR SET MUST BE ENCLOSED TO PREVENT PEST INTRUSION AND RECIRCULATION OF DISCHARGE AIR AND/OR IMPROPER COOLING AIR FLOW.
- REFERENCE OWNERS MANUAL FOR LIFTING WARNINGS.
- MOUNTING BOLTS OR STUDS TO MOUNTING SURFACE SHALL BE 5/8-11 GRADE 5 (USE STANDARD SAE TORQUE SPECS)
- MUST ALLOW FREE FLOW OF INTAKE AIR, DISCHARGE AIR AND EXHAUST. SEE SPEC SHEET FOR MINIMUM AIR FLOW AND MAXIMUM RESTRICTION REQUIREMENTS.
- GENERATOR MUST BE INSTALLED SUCH THAT FRESH COOLING AIR IS AVAILABLE AND THAT DISCHARGE AIR FROM RADIATOR IS NOT RECIRCULATED.
- EXHAUST MUFFLER AND FAN BELT ENCLOSED WITHIN GENERATOR ENCLOSURE, REMOVE FRONT PANEL TO ACCESS.

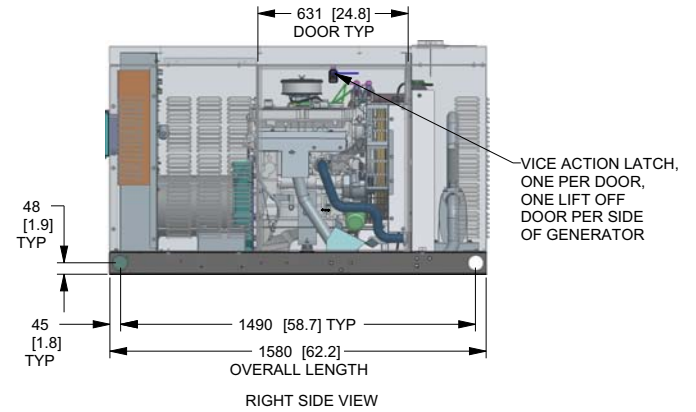
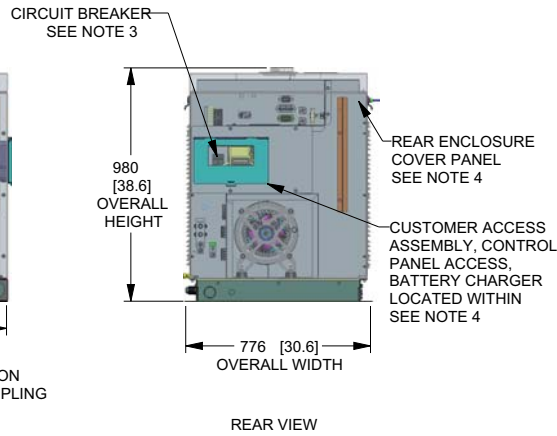
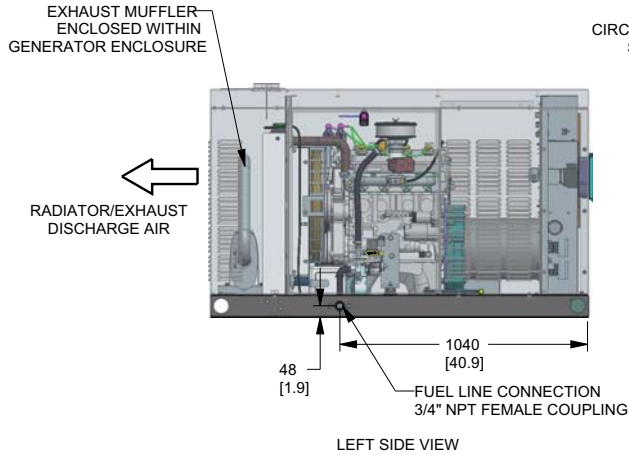

WEIGHT DATA				
ENGINE/KW	ENCLOSURE MATERIAL	WEIGHT GENSET ONLY KG [LBS]	WEIGHT SHIPPING SKID KG [LBS]	SHIPPING WEIGHT KG [LBS]
2.4L 22KW	AL	410.5 [905]	30 [66]	440 [971]
2.4L 27KW	AL	426 [940]	30 [66]	456 [1006]

DIMENSIONS: MM [INCH]

0K8624-A 22/27 kW (2.4 L) Page 2 of 2

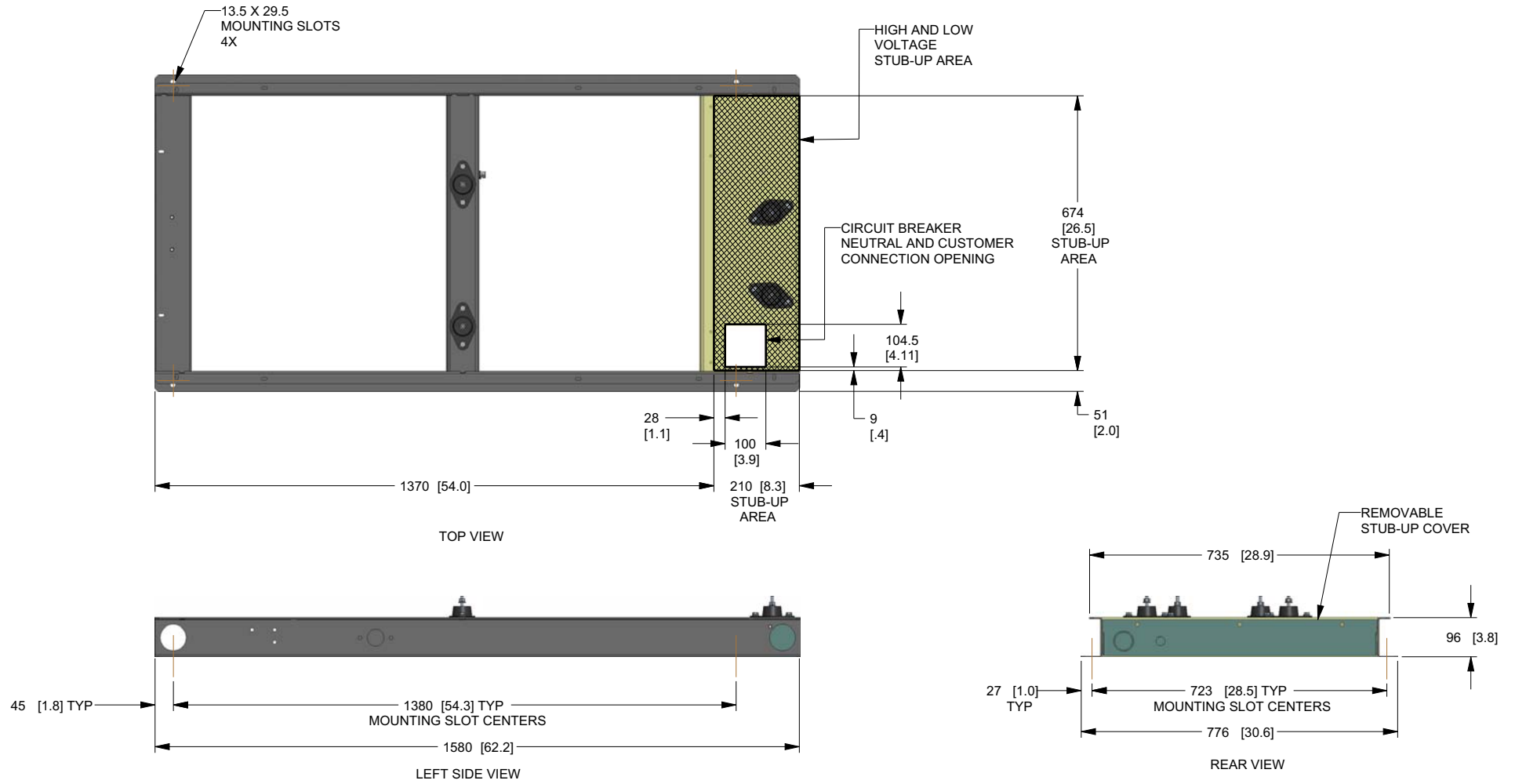

DIMENSIONS: MM [INCH]

9.3 — 0K8636-A 36/45 kW (2.4 L) Page 1 of 2

REMOVE COVER FOR ACCESS TO RADIATOR FILL CAP

AIR INTAKE (BOTH SIDES)

RADIATOR/EXHAUST DISCHARGE AIR (BOTH SIDES)

443 [17.5]

187 [7.4]

BATTERY 12V GROUP 26 NEGATIVE GROUND P/N: 077483

749.3 [29.5]

CENTER OF GRAVITY (SEE NOTE 5)

REMOVE COVER FOR ACCESS TO LUBE OIL MAINTAINER SUPPLY TANK
REFERENCE OWNERS MANUAL

TOP VIEW

EXHAUST MUFFLER ENCLOSED WITHIN GENERATOR ENCLOSURE

RADIATOR/EXHAUST DISCHARGE AIR

50 [2.0]

1000 [39.4]

FUEL LINE CONNECTION 3/4" NPT FEMALE COUPLING

LEFT SIDE VIEW

CIRCUIT BREAKER SEE NOTE 3

1170 [46.1]

OVERALL HEIGHT

888 [35.0]

OVERALL WIDTH

REAR VIEW

REAR ENCLOSURE COVER PANEL SEE NOTE 4

CUSTOMER ACCESS ASSEMBLY, CONTROL PANEL ACCESS, BATTERY CHARGER LOCATED WITHIN SEE NOTE 4

58 [2.3] TYP

46.5 [1.83]

758 [29.8]

DOOR TYP

VICE ACTION LATCH, ONE PER DOOR, ONE LIFT OFF DOOR PER SIDE OF GENERATOR

1857 [73.1] TYP

1950 [76.8]

OVERALL LENGTH

RIGHT SIDE VIEW

WEIGHT DATA				
ENGINE/KW	ENCLOSURE MATERIAL	WEIGHT GENSET ONLY KG [LBS]	WEIGHT SHIPPING SKID KG [LBS]	SHIPPING WEIGHT KG [LBS]
2.4L 36KW	ST	569 [1255]	44 [98]	613 [1353]
2.4L 36KW	AL	545 [1202]	44 [98]	590 [1300]
2.4L 45KW	ST	596 [1313]	44 [98]	640 [1411]
2.4L 45KW	AL	572 [1260]	44 [98]	616 [1358]

DIMENSIONS: MM [INCH]

SERVICE ITEM	2.4L
OIL FILL CAP	EITHER SIDE
OIL DIP STICK	RIGHT SIDE
OIL FILTER	RIGHT SIDE
OIL DRAIN HOSE	RIGHT SIDE
RADIATOR DRAIN HOSE	LEFT SIDE
COOLANT RECOVERY BOTTLE	LEFT SIDE
RADIATOR FILL CAP	ROOF TOP
AIR CLEANER ELEMENT	LEFT SIDE
SPARK PLUGS	LEFT SIDE
MUFFLER	SEE NOTE 11
DRIVE BELT	EITHER SIDE
FAN BELT	SEE NOTE 11
BATTERY	LEFT SIDE
LUBE OIL MAINTAINER SUPPLY TANK FILL CAP	ROOF TOP

REFERENCE OWNERS MANUAL FOR PERIODIC REPLACEMENT PART LISTINGS.

NOTES:

- MINIMUM RECOMMENDED CONCRETE PAD SIZE: 1194MM (47") WIDE X 2256MM (88.8") LONG. REFERENCE INSTALLATION GUIDE SUPPLIED WITH UNIT FOR CONCRETE PAD GUIDELINES.
- ALLOW SUFFICIENT ROOM ON ALL SIDES OF THE GENERATOR FOR MAINTENANCE AND SERVICING. THIS UNIT MUST BE INSTALLED IN ACCORDANCE WITH CURRENT APPLICABLE NFPA 37 AND NFPA 70 STANDARDS AS WELL AS ANY OTHER FEDERAL, STATE, AND LOCAL CODES.
- CONTROL PANEL / CIRCUIT BREAKER INFORMATION:
 - SEE SPECIFICATION SHEET OR OWNERS MANUAL
 - ACCESSIBLE THROUGH CUSTOMER ACCESS ASSEMBLY DOOR ON REAR OF GENERATOR.
- REMOVE THE REAR ENCLOSURE COVER PANEL TO ACCESS THE STUB-UP AREAS AS FOLLOWS:
 - HIGH VOLTAGE CONNECTION INCLUDING AC LOAD LEAD CONDUIT CONNECTION NEUTRAL CONNECTION, BATTERY CHARGER 120 VOLT AC (0.5 AMP MAX) CONNECTION.
 - LOW VOLTAGE CONNECTION INCLUDING TRANSFER SWITCH CONTROL WIRES.
- CENTER OF GRAVITY AND WEIGHT MAY CHANGE DUE TO UNIT OPTIONS.
- BOTTOM OF GENERATOR SET MUST BE ENCLOSED TO PREVENT PEST INTRUSION AND RECIRCULATION OF DISCHARGE AIR AND/OR IMPROPER COOLING AIR FLOW.
- REFERENCE OWNERS MANUAL FOR LIFTING WARNINGS.
- MOUNTING BOLTS OR STUDS TO MOUNTING SURFACE SHALL BE 5/8-11 GRADE 5 (USE STANDARD SAE TORQUE SPECS)
- MUST ALLOW FREE FLOW OF INTAKE AIR, DISCHARGE AIR AND EXHAUST. SEE SPEC SHEET FOR MINIMUM AIR FLOW AND MAXIMUM RESTRICTION REQUIREMENTS.
- GENERATOR MUST BE INSTALLED SUCH THAT FRESH COOLING AIR IS AVAILABLE AND THAT DISCHARGE AIR FROM RADIATOR IS NOT RECIRCULATED.
- EXHAUST MUFFLER AND FAN BELT ENCLOSED WITHIN GENERATOR ENCLOSURE, REMOVE FRONT PANEL TO ACCESS.

0K8636-A 36/45 kW (2.4 L) Page 2 of 2

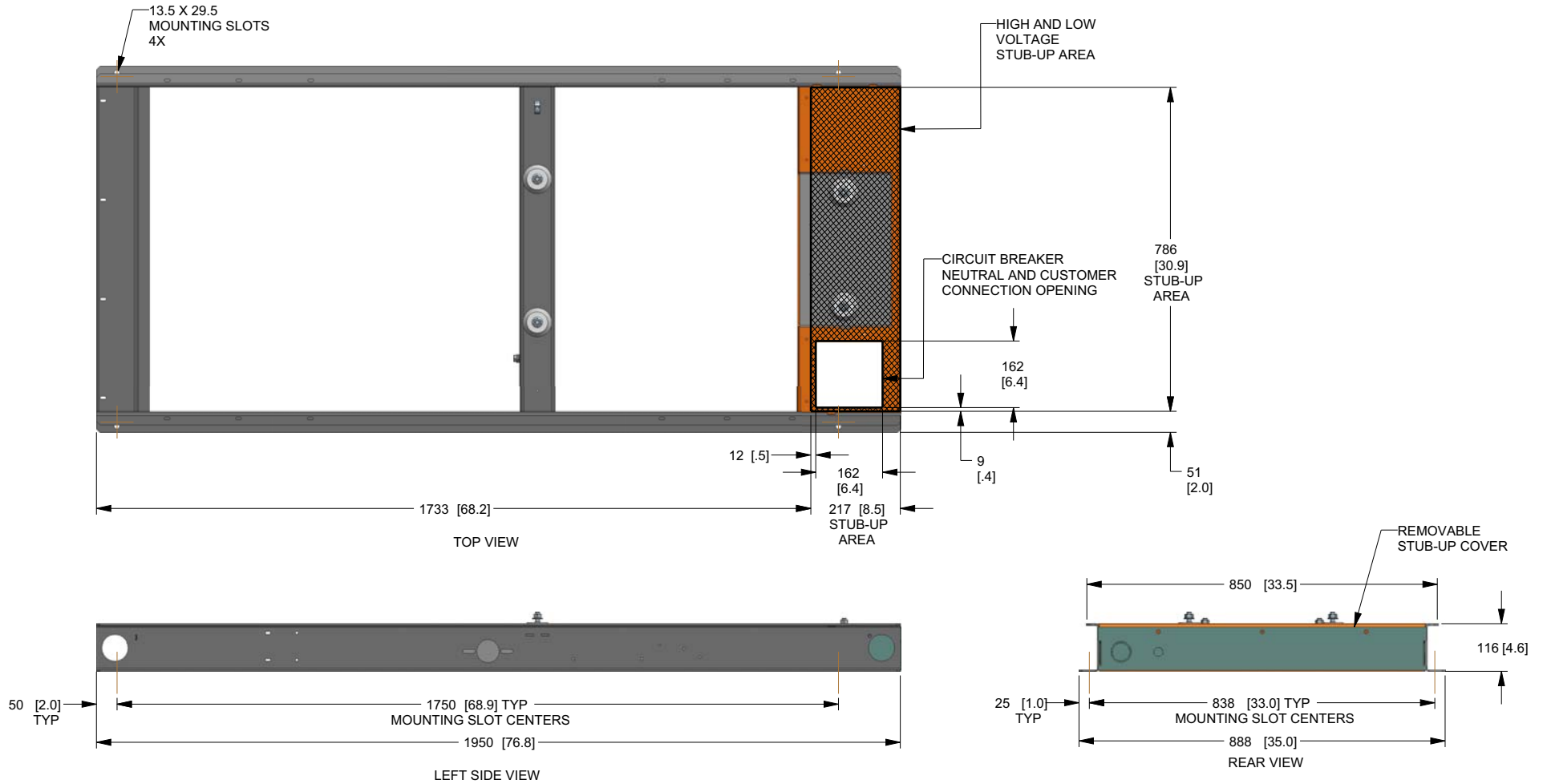

DIMENSIONS: MM [INCH]

9.4 — 0K9268-A 32/38 kW (2.4 L) Page 1 of 2

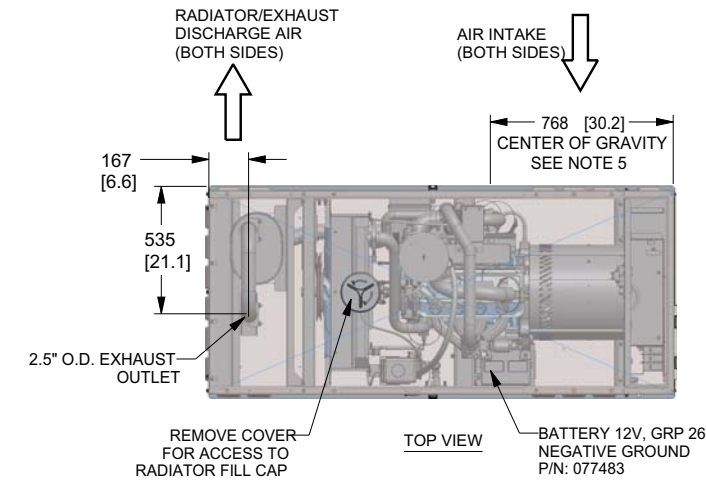

SERVICE ITEM	2.4L
OIL FILL CAP	EITHER SIDE
OIL DIP STICK	RIGHT SIDE
OIL FILTER	RIGHT SIDE
OIL DRAIN HOSE	RIGHT SIDE
RADIATOR DRAIN HOSE	LEFT SIDE
COOLANT RECOVERY BOTTLE	LEFT SIDE
RADIATOR FILL CAP ACCESS	ROOF TOP
AIR CLEANER ELEMENT	RIGHT SIDE
SPARK PLUGS	LEFT SIDE
MUFFLER	SEE NOTE 11
DRIVE BELT	EITHER SIDE
FAN BELT	SEE NOTE 11
BATTERY	LEFT SIDE

REFERENCE OWNERS MANUAL FOR PERIODIC REPLACEMENT PART LISTINGS.

NOTES:

1. MINIMUM RECOMMENDED CONCRETE PAD SIZE: 1194 (47") WIDE X 2255 (88.8") LONG. REFERENCE INSTALLATION GUIDE SUPPLIED WITH UNIT FOR CONCRETE PAD GUIDELINES.
2. ALLOW SUFFICIENT ROOM ON ALL SIDES OF THE GENERATOR FOR MAINTENANCE AND SERVICING. THIS UNIT MUST BE INSTALLED IN ACCORDANCE WITH CURRENT APPLICABLE NFPA 37 AND NFPA 70 STANDARDS AS WELL AS ANY OTHER FEDERAL, STATE, AND LOCAL CODES.
3. CONTROL PANEL / CIRCUIT BREAKER INFORMATION:
 - SEE SPECIFICATION SHEET OR OWNERS MANUAL
 - ACCESSIBLE THROUGH CUSTOMER ACCESS ASSEMBLY DOOR ON REAR OF GENERATOR.
4. REMOVE THE REAR ENCLOSURE COVER PANEL TO ACCESS THE STUB-UP AREAS AS FOLLOWS:
 - HIGH VOLTAGE CONNECTION INCLUDING AC LOAD LEAD CONDUIT CONNECTION, NEUTRAL CONNECTION, AND BATTERY CHARGER 120 VOLT AC (0.5 AMP MAX) CONNECTION.
 - LOW VOLTAGE CONNECTION INCLUDING TRANSFER SWITCH CONTROL WIRES.
5. CENTER OF GRAVITY AND WEIGHT MAY CHANGE DUE TO UNIT OPTIONS.
6. BOTTOM OF GENERATOR SET MUST BE ENCLOSED TO PREVENT PEST INTRUSION AND RECIRCULATION OF DISCHARGE AIR AND/OR IMPROPER COOLING AIR FLOW.
7. REFERENCE OWNERS MANUAL FOR LIFTING WARNINGS.
8. MOUNTING BOLTS OR STUDS TO MOUNTING SURFACE SHALL BE 5/8-11 GRADE 5 (USE STANDARD SAE TORQUE SPECS)
9. MUST ALLOW FREE FLOW OF INTAKE AIR, DISCHARGE AIR AND EXHAUST. SEE SPEC SHEET FOR MINIMUM AIR FLOW AND MAXIMUM RESTRICTION REQUIREMENTS.
10. GENERATOR MUST BE INSTALLED SUCH THAT FRESH COOLING AIR IS AVAILABLE AND THAT DISCHARGE AIR FROM RADIATOR IS NOT RECIRCULATED.
11. EXHAUST MUFFLER AND FAN BELT ARE ENCLOSED WITHIN GENERATOR ENCLOSURE, REMOVE FRONT PANEL TO ACCESS.

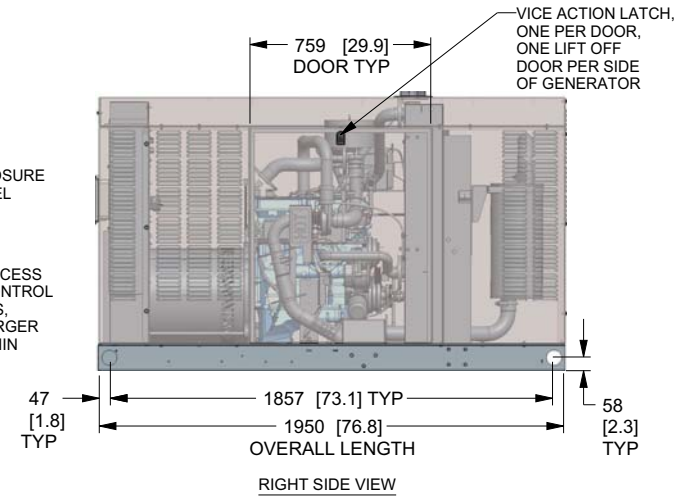
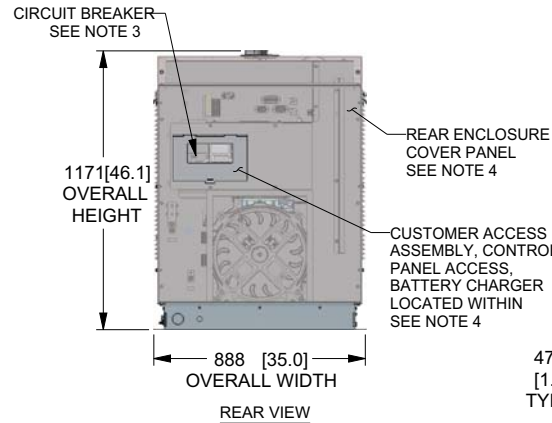
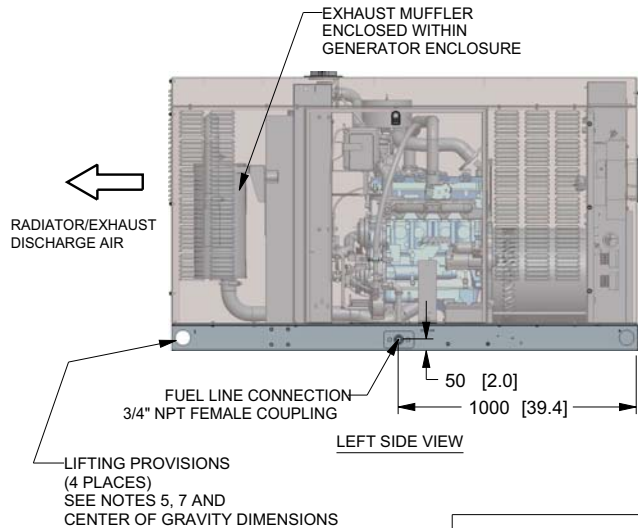

WEIGHT DATA				
ENGINE/KW	ENCLOSURE MATERIAL	WEIGHT GENSET ONLY KG [LBS]	WEIGHT SHIPPING SKID KG [LBS]	SHIPPING WEIGHT KG [LBS]
2.4L 32KW	AL	556 [1225]	44 [98]	600 [1323]
2.4L 38KW	AL	560 [1235]	44 [98]	605 [1333]

DIMENSIONS: MM [INCH]

0K9268-A 32/38 kW (2.4 L) Page 2 of 2

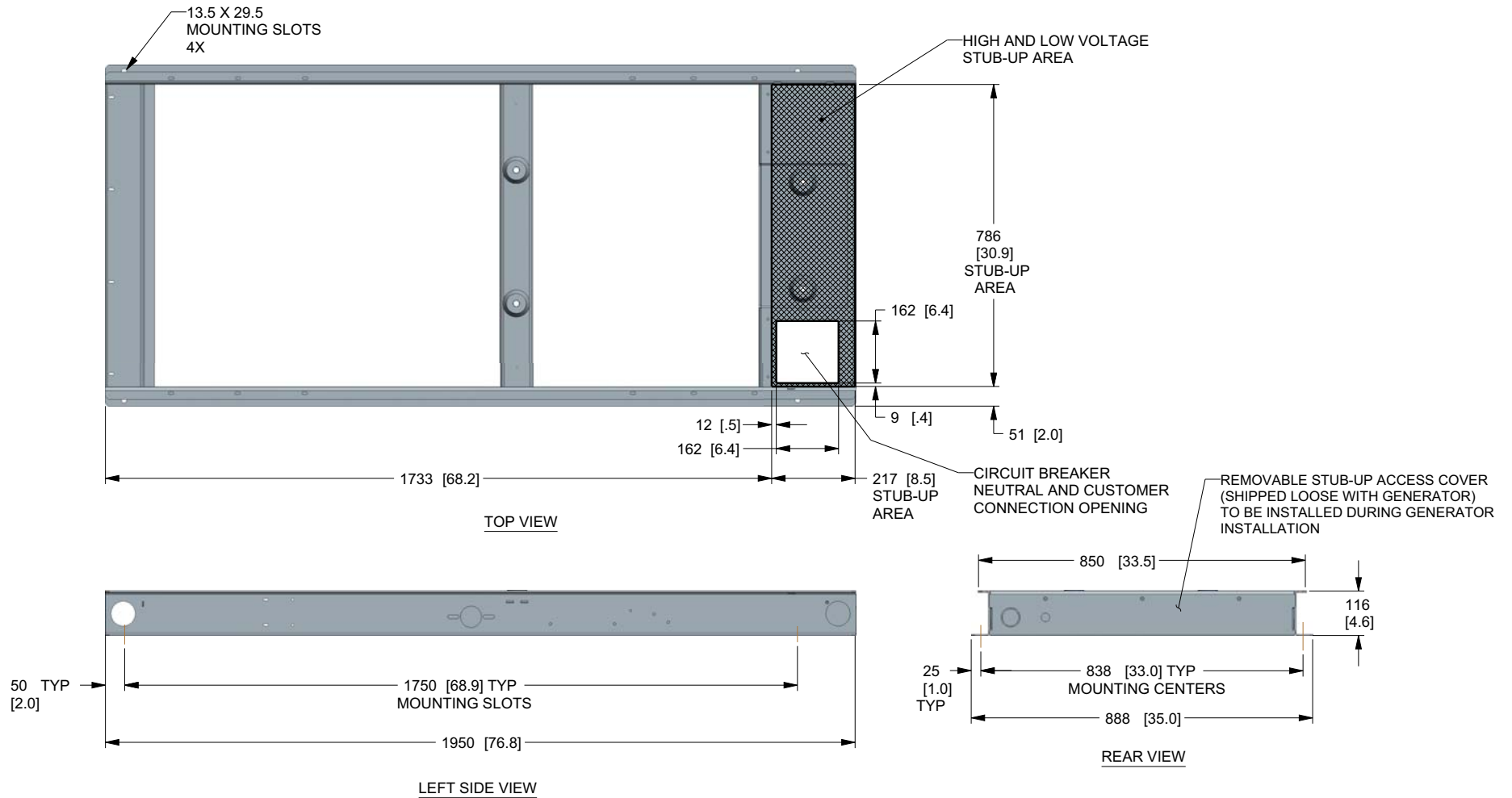

DIMENSIONS: MM [INCH]

9.5 — 0L2090-A 60 kW (2.4 L) Page 1 of 2

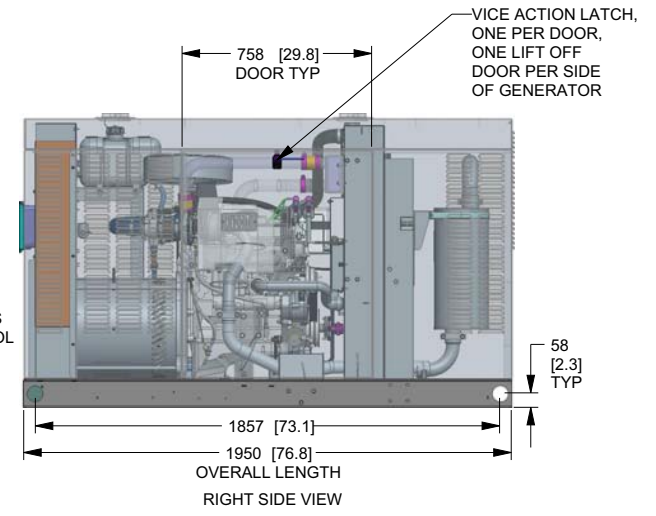
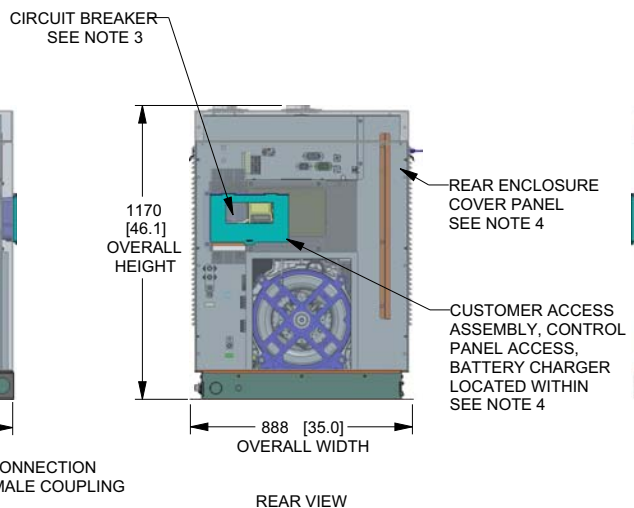
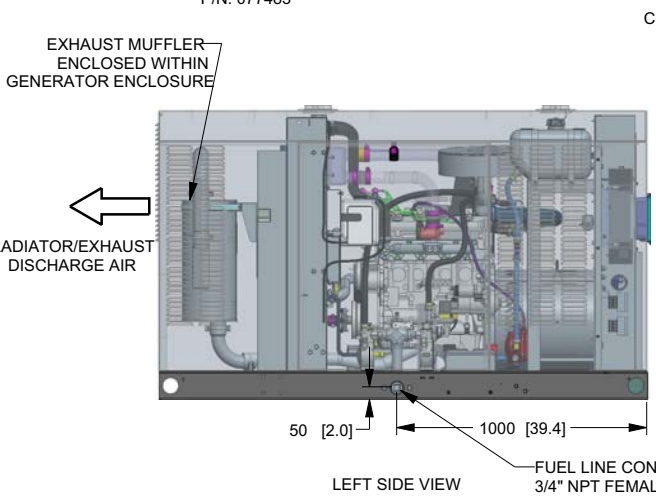
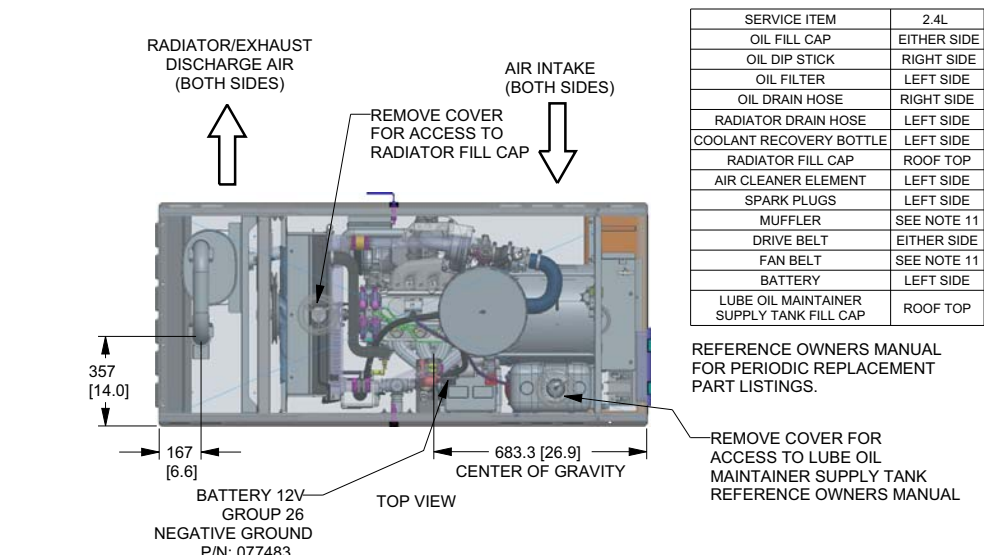

WEIGHT DATA				
ENGINE/KW	ENCLOSURE MATERIAL	WEIGHT GENSET ONLY KG [LBS]	WEIGHT SHIPPING SKID KG [LBS]	SHIPPING WEIGHT KG [LBS]
2.4L 60KW	ST	582 [1283]	44 [98]	626 [1381]
2.4L 60KW	AL	558 [1230]	44 [98]	602 [1328]

DIMENSIONS: MM [INCH]

- NOTES:**
1. MINIMUM RECOMMENDED CONCRETE PAD SIZE: 1194MM (47") WIDE X 2256MM (88.8") LONG. REFERENCE INSTALLATION GUIDE SUPPLIED WITH UNIT FOR CONCRETE PAD GUIDELINES.
 2. ALLOW SUFFICIENT ROOM ON ALL SIDES OF THE GENERATOR FOR MAINTENANCE AND SERVICING. THIS UNIT MUST BE INSTALLED IN ACCORDANCE WITH CURRENT APPLICABLE NFPA 37 AND NFPA 70 STANDARDS AS WELL AS ANY OTHER FEDERAL, STATE, AND LOCAL CODES.
 3. CONTROL PANEL / CIRCUIT BREAKER INFORMATION:
 - SEE SPECIFICATION SHEET OR OWNERS MANUAL
 - ACCESSIBLE THROUGH CUSTOMER ACCESS ASSEMBLY DOOR ON REAR OF GENERATOR.
 4. REMOVE THE REAR ENCLOSURE COVER PANEL TO ACCESS THE STUB-UP AREAS AS FOLLOWS:
 - HIGH VOLTAGE CONNECTION INCLUDING AC LOAD LEAD CONDUIT CONNECTION NEUTRAL CONNECTION, BATTERY CHARGER 120 VOLT AC (0.5 AMP MAX) CONNECTION.
 - LOW VOLTAGE CONNECTION INCLUDING TRANSFER SWITCH CONTROL WIRES.
 5. CENTER OF GRAVITY AND WEIGHT MAY CHANGE DUE TO UNIT OPTIONS.
 6. BOTTOM OF GENERATOR SET MUST BE ENCLOSED TO PREVENT PEST INTRUSION AND RECIRCULATION OF DISCHARGE AIR AND/OR IMPROPER COOLING AIR FLOW.
 7. REFERENCE OWNERS MANUAL FOR LIFTING WARNINGS.
 8. MOUNTING BOLTS OR STUDS TO MOUNTING SURFACE SHALL BE 5/8-11 GRADE 5 (USE STANDARD SAE TORQUE SPECS)
 9. MUST ALLOW FREE FLOW OF INTAKE AIR, DISCHARGE AIR AND EXHAUST. SEE SPEC SHEET FOR MINIMUM AIR FLOW AND MAXIMUM RESTRICTION REQUIREMENTS.
 10. GENERATOR MUST BE INSTALLED SUCH THAT FRESH COOLING AIR IS AVAILABLE AND THAT DISCHARGE AIR FROM RADIATOR IS NOT RECIRCULATED.
 11. EXHAUST MUFFLER AND FAN BELT ENCLOSED WITHIN GENERATOR ENCLOSURE, REMOVE FRONT PANEL TO ACCESS.

0L2090-A 60 kW (2.4 L) Page 2 of 2

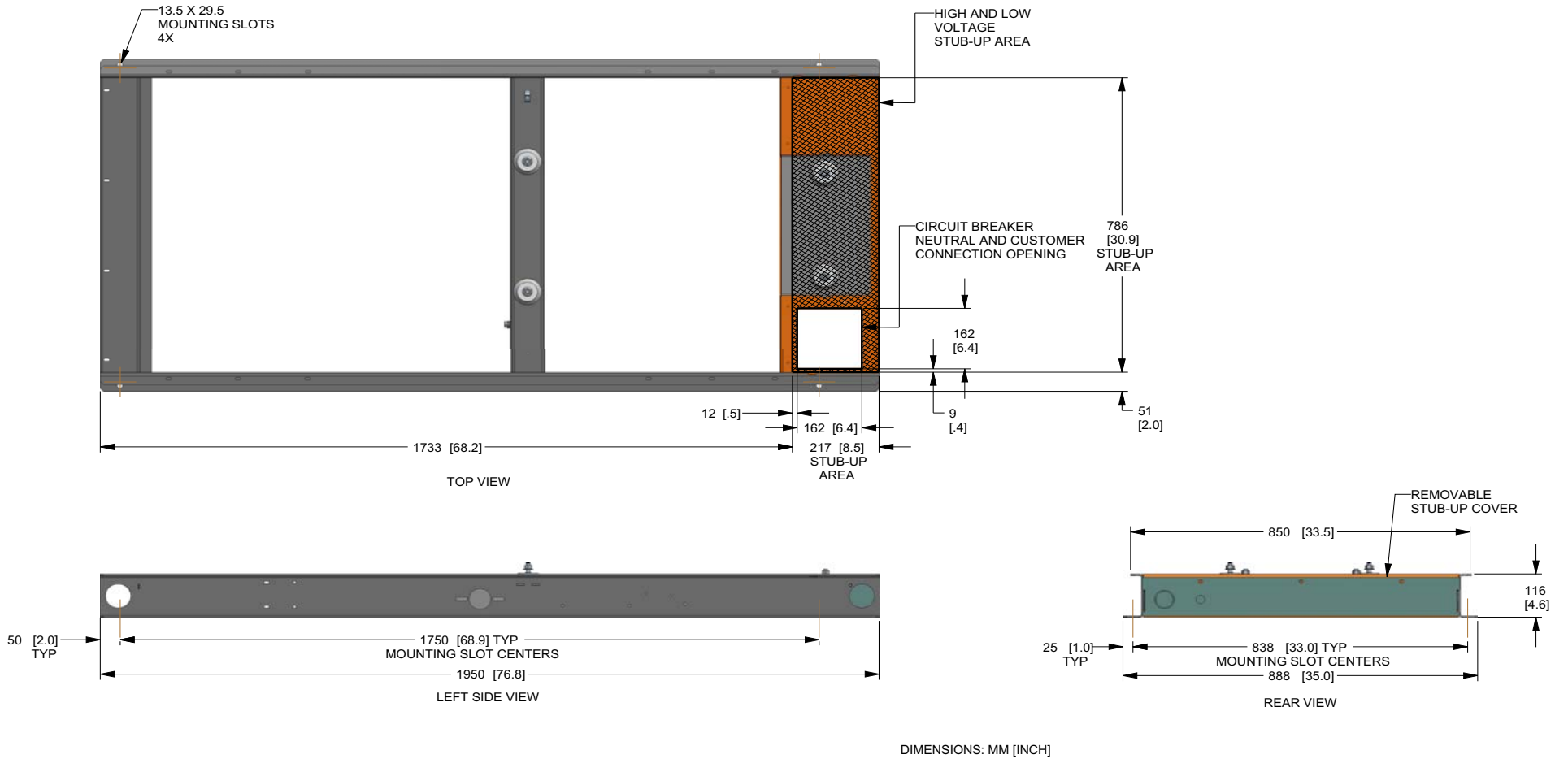

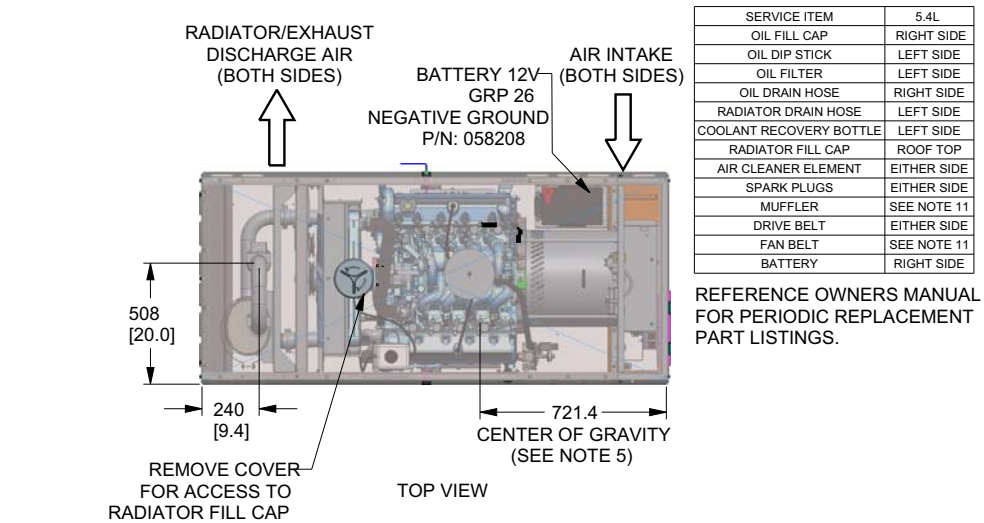

SERVICE ITEM	5.4L
OIL FILL CAP	RIGHT SIDE
OIL DIP STICK	LEFT SIDE
OIL FILTER	LEFT SIDE
OIL DRAIN HOSE	RIGHT SIDE
RADIATOR DRAIN HOSE	LEFT SIDE
COOLANT RECOVERY BOTTLE	LEFT SIDE
RADIATOR FILL CAP	ROOF TOP
AIR CLEANER ELEMENT	EITHER SIDE
SPARK PLUGS	EITHER SIDE
MUFFLER	SEE NOTE 11
DRIVE BELT	EITHER SIDE
FAN BELT	SEE NOTE 11
BATTERY	RIGHT SIDE

REFERENCE OWNERS MANUAL FOR PERIODIC REPLACEMENT PART LISTINGS.

NOTES:

- MINIMUM RECOMMENDED CONCRETE PAD SIZE: 1194 (47") WIDE X 2256 (88.8") LONG. REFERENCE INSTALLATION GUIDE SUPPLIED WITH UNIT FOR CONCRETE PAD GUIDELINES.
- ALLOW SUFFICIENT ROOM ON ALL SIDES OF THE GENERATOR FOR MAINTENANCE AND SERVICING. THIS UNIT MUST BE INSTALLED IN ACCORDANCE WITH CURRENT APPLICABLE NFPA 37 AND NFPA 70 STANDARDS AS WELL AS ANY OTHER FEDERAL, STATE, AND LOCAL CODES.
- CONTROL PANEL / CIRCUIT BREAKER INFORMATION:
- SEE SPECIFICATION SHEET OR OWNERS MANUAL
- ACCESSIBLE THROUGH CUSTOMER ACCESS ASSEMBLY DOOR ON REAR OF GENERATOR.
- REMOVE THE REAR ENCLOSURE COVER PANEL TO ACCESS THE STUB-UP AREAS AS FOLLOWS:
- HIGH VOLTAGE CONNECTION INCLUDING AC LOAD LEAD CONDUIT CONNECTION NEUTRAL CONNECTION, BATTERY CHARGER 120 VOLT AC (0.5 AMP MAX) CONNECTION.
- LOW VOLTAGE CONNECTION INCLUDING TRANSFER SWITCH CONTROL WIRES.
- CENTER OF GRAVITY AND WEIGHT MAY CHANGE DUE TO UNIT OPTIONS.
- BOTTOM OF GENERATOR SET MUST BE ENCLOSED TO PREVENT PEST INTRUSION AND RECIRCULATION OF DISCHARGE AIR AND/OR IMPROPER COOLING AIR FLOW.
- REFERENCE OWNERS MANUAL FOR LIFTING WARNINGS.
- MOUNTING BOLTS OR STUDS TO MOUNTING SURFACE SHALL BE 5/8-11 GRADE 5 (USE STANDARD SAE TORQUE SPECS)
- MUST ALLOW FREE FLOW OF INTAKE AIR, DISCHARGE AIR AND EXHAUST. SEE SPEC SHEET FOR MINIMUM AIR FLOW AND MAXIMUM RESTRICTION REQUIREMENTS.
- GENERATOR MUST BE INSTALLED SUCH THAT FRESH COOLING AIR IS AVAILABLE AND THAT DISCHARGE AIR FROM RADIATOR IS NOT RECIRCULATED.
- EXHAUST MUFFLER AND FAN BELT ENCLOSED WITHIN GENERATOR ENCLOSURE, REMOVE FRONT PANEL TO ACCESS.

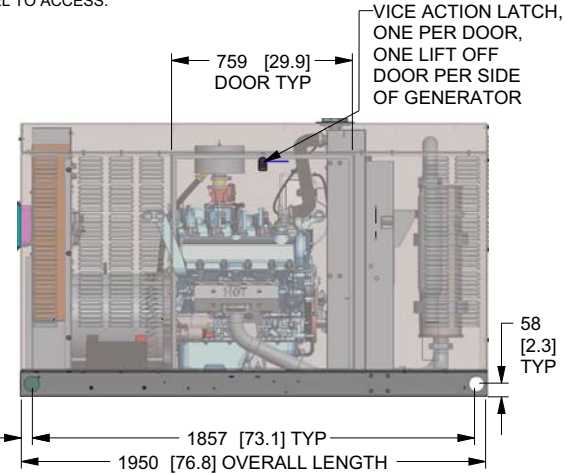
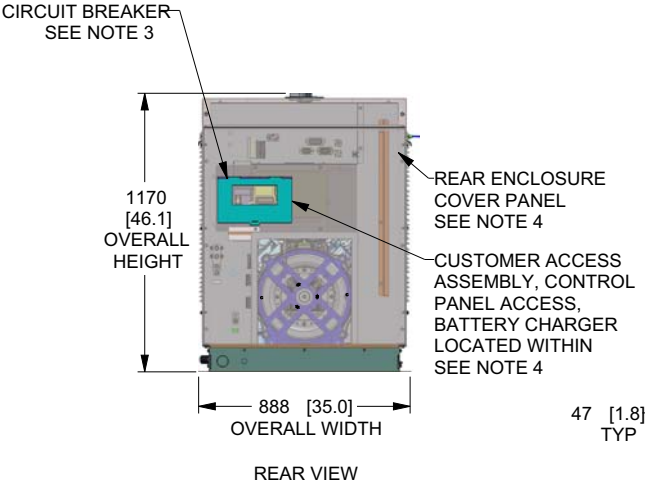
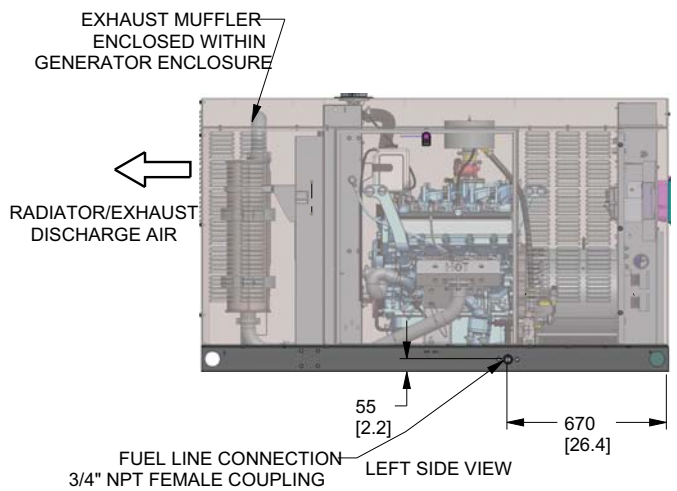

WEIGHT DATA				
ENGINE/KW	ENCLOSURE MATERIAL	WEIGHT GENSET ONLY KG [LBS]	WEIGHT SHIPPING SKID KG [LBS]	SHIPPING WEIGHT KG [LBS]
5.4L/48KW	AL	705 [1555]	44 [98]	750 [1653]

0K9243-A 48 kW (5.4 L) Page 1 of 2

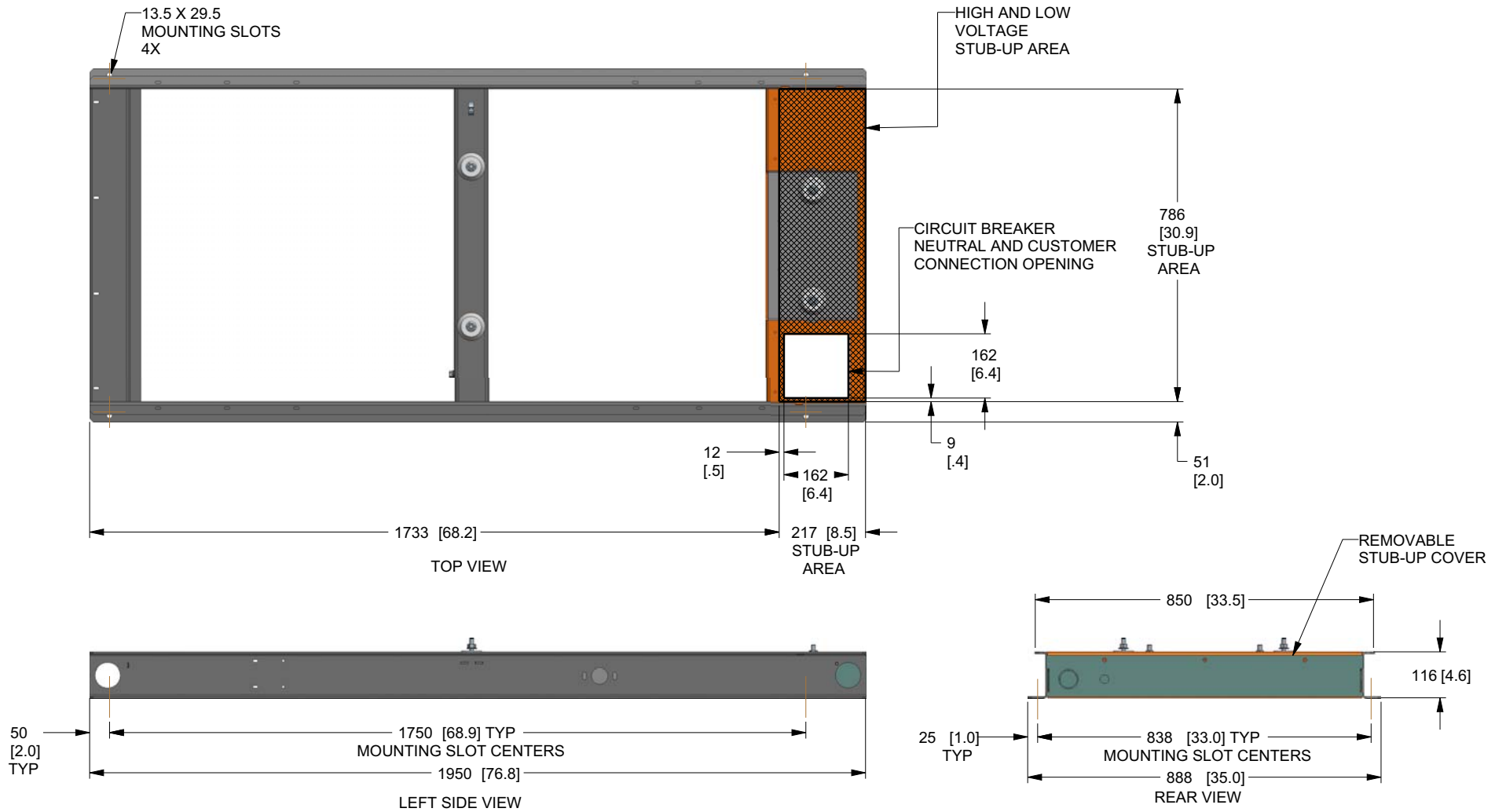

DIMENSIONS: MM [INCH]

Part No. 0K8419 Rev. A 02/23/2015 Printed in USA
©2015 Generac Power Systems, Inc. All rights reserved
Specifications are subject to change without notice.
No reproduction allowed in any form without prior written
consent from Generac Power Systems, Inc.

Generac Power Systems, Inc.
S45 W29290 Hwy. 59
Waukesha, WI 53189
1-888-GENERAC (1-888-436-3722)
generac.com

Installation Guidelines

For

Spark-Ignited Stationary Emergency Generators

Residential and Commercial

22 kW	2.4L
25 kW	1.5L
27 kW	2.4L
30 kW	1.5L
32 kW	2.4L
36 kW	2.4L
38 kW	2.4L
45 kW	2.4L
48 kW	5.4L
60 kW	2.4L

⚠ DANGER!



NOT INTENDED FOR USE IN CRITICAL LIFE SUPPORT APPLICATIONS.



ONLY QUALIFIED ELECTRICIANS OR CONTRACTORS SHOULD ATTEMPT INSTALLATION!



DEADLY EXHAUST FUMES! OUTDOOR INSTALLATION ONLY!

This manual should remain with the unit.

This manual must be used in conjunction with the appropriate owner's manual.

Para español , visita : <http://www.generac.com/service-support/product-support-lookup>

Pour le français, visiter : <http://www.generac.com/service-support/product-support-lookup>

Forward

Purpose and Scope of This Manual

READ THIS MANUAL THOROUGHLY. This manual has been prepared to familiarize personnel involved with the installation of generator sets with the manufacturer's installation requirements. Information and instructions contained herein are not intended to replace or supersede, local, state, or national safety, electrical, and building codes pertaining to such installations. Applicable laws, codes, and standards must always take precedence over the recommendations contained herein. Always check with the local Authority Having Jurisdiction (AHJ) for the codes or standards that apply.

Only authorized dealers or qualified, competent installation contractors or electricians thoroughly familiar with applicable codes, standards, and regulations should install this standby electric power system. The installation must be in strict compliance with all codes, standards, and regulations. Start-up procedures must be performed by an Authorized Generac Service Dealer.

It is not intended that this manual be used by any unqualified person for the purpose of installing a generator set. Installation, inspection, and testing of the system should be attempted only by competent, qualified electricians or installation contractors who are familiar with the equipment and with all installation codes and requirements.

It would be impossible to provide detailed coverage of every installation configuration. For this reason, much of the information contained in this manual is general in nature. Illustrations of typical installations are not intended to serve as detailed installation plans. Always have the drawings and manuals for the specific unit being installed before beginning the installation.

The information in this manual can be used in the planning and design process phase of selecting and purchasing a generator set for a standby power application.

Sources of Information

Installation information and recommendations contained herein are derived from the following sources:

- Knowledgeable engineers, service technicians, and service representatives.
- The National Electric Code (NEC).
- National Fire Protection Association (NFPA) codes and standards.
- Other sources as listed in Subsection 1.7.
- Various manufacturing standards and best practices.

▲ CAUTION!



If this generator is used to power electrical load circuits normally powered by a utility power source, it is required by code to install a transfer switch. The transfer switch must effectively isolate the electric system from the utility distribution system when the generator is operating. Failure to isolate an electrical system by such means may result in damage to the generator and may also result in injury or even death to utility power workers due to backfeed of electrical energy.



If an open bottom is used, the engine-generator is to be installed over non-combustible materials and should be located such that combustible materials are not capable of accumulating under the generator set.



After the system has been installed, do nothing that might render the installation in non-compliance with such codes, standards, and regulations.

Every effort was made to ensure the information in this manual was both accurate and current at the time it was released. However, the manufacturer reserves the right to change, alter, or otherwise improve this product at any time and without prior notice.

Table of Contents

Section 1 Safety

1.1 Introduction	1
1.2 Safety Rules	1
1.3 General Hazards	2
1.4 Electrical Hazards	2
1.5 Fire Hazards	3
1.6 Explosion Hazards	3
1.7 Standards Index	3

Section 2 Installation Planning

2.1 Protector Pre-Order Checklist	5
2.2 Unit Drawings	5
2.2.1 Installation Drawings	5
2.2.2 Wiring Diagrams	6
2.3 Receiving	6
2.3.1 Receiving and Unpacking	6
2.3.2 Inspection	6
2.4 Storage Before Installation	6
2.4.1 Long Term Storage	6
2.4.2 Short Term Storage	6
2.5 Lifting	7
2.6 Generator Location	7
2.6.1 General Location Guidelines	7
2.6.2 Weather Considerations	8
2.7 Accessories	8

Section 3 Foundations & Mounting

3.1 Generator Foundations	11
3.1.1 Concrete Pad	11
3.1.2 Dimensions	11
3.1.3 Unit Clearance	11
3.1.4 Stub Up Area	11
3.2 Mounting	12
3.2.1 Fixed Foundation	12
3.2.2 Connections	12
3.2.3 Combustible Floor and Roof Protection	12

Section 4 Ventilation System

4.1 General	15
4.2 Outdoor Installation Only	15

Section 5 Gaseous Fuel Systems

5.1 General	17
5.1.1 Fuel System Conversion	17
5.2 Gaseous Fuel Properties	17
5.2.1 Natural Gas	17
5.2.2 Propane Vapor (LPV)	17
5.3 Gaseous Fuel Systems	17
5.3.1 Natural Gas System	17
5.3.2 LP-Vapor Withdrawal System	18
5.3.3 Drip Leg	19
5.4 Fuel Pressure Regulators	19
5.4.1 General	19
5.4.2 Definitions	20
5.4.3 Best Practices	20
5.4.4 Operating Fuel Pressure	21
5.4.5 Engine Fuel Consumption	21
5.4.6 Fuel Pressure Regulator Sizing	21
5.4.7 Recommended Fuel Pressure Regulators	22
5.4.8 Primary Fuel Pressure Regulator	22
5.5 Pipe Sizing Considerations	22
5.5.1 General	22
5.5.2 Sizing LP Tanks for Vapor Withdrawal	24
5.6 Final Operating Test	26
5.6.1 Gas Pressure Test Port Location	26
5.6.2 Final Test Procedure	27

Section 6 Electrical System

6.1 General Information	29
6.2 Remove Rear Panel and Stub Up Cover	29
6.3 Wiring Installation Safety	29
6.4 General Wiring Requirements	29
6.5 High Voltage Connections	29
6.6 Control Wiring Connections	32
6.6.1 RTS Series Transfer Switch With T1 Fuse/Connection	32
6.6.2 RTS Series Transfer Switch Without T1 Fuse/Connection	33
6.6.3 Two-Wire Start	33

6.7 Optional Accessory Power	34
6.8 Install Stub Up Cover and Rear Panel	34
6.9 Transfer Switch Location	34
6.10 Battery	34
6.10.1 General Cautions	34
6.10.2 Battery Size	35
6.10.3 Battery Installation	35
6.11 Activate Unit	37
6.12 Operational Checks	38
6.12.1 Self Test	38
6.12.2 Check Manual Transfer Switch Operation	38
6.12.3 Electrical Checks	39
6.12.4 Test Generator Under Load	39
6.12.5 Check Automatic Operation	40
6.13 Installation Summary	40

Section 7 Lube Oil Maintainer System

7.1 Lube Oil Maintainer System	41
7.1.1 Description	41
7.1.2 Fill Oil Supply Tank	42
7.1.3 Test Functionality	42
7.1.4 Shutoff Valve	42

Section 8 Installation Checklists

8.1 Safety Checklist	45
8.2 Installation Planning Checklist	45
8.3 Foundations and Mounting Checklist	45
8.4 Ventilation System Checklist	46
8.5 Exhaust System Checklist	46
8.6 Gaseous Fuel System Checklist	47
8.7 Electrical System Checklist	47
8.8 Oil Maintainer System Checklist	48

Section 9 Installation Drawings

9.1 0K8420-A 25/30 kW (1.5 L).....	49
9.2 0K8624-A 22/27 kW (2.4 L).....	51
9.3 0K8636-A 36/45 kW (2.4 L).....	53
9.4 0K9268-A 32/38 kW (2.4 L).....	55
9.5 0L2090-A 60 kW (2.4 L)	57
9.6 0K9243-A 48 kW (5.4 L).....	59

⚠ WARNING

California Proposition 65. Engine exhaust and some of its constituents are known to the state of California to cause cancer, birth defects, and other reproductive harm. (000004)

⚠ WARNING

California Proposition 65. This product contains or emits chemicals known to the state of California to cause cancer, birth defects, and other reproductive harm. (000005)

Section 1 Safety

1.1 — Introduction

Read this manual thoroughly. If any portion is not understood, contact the nearest Authorized Service Dealer for clarification. The manufacturer also requires having an Authorized Service Dealer oversee the installation of any standby generator set. Trained/qualified service technicians familiar with the control systems and available options have full access to drawings, publications, and other information required for a successful installation.

1.2 — Safety Rules

Throughout this publication, and on tags and decals affixed to the generator, DANGER, WARNING, CAUTION, and NOTE boxes are used to alert personnel to special instructions about a particular operation that may be hazardous if performed incorrectly or carelessly. Observe them carefully. They indicate:

⚠ DANGER!

INDICATES A HAZARDOUS SITUATION OR ACTION WHICH, IF NOT AVOIDED, WILL RESULT IN DEATH OR SERIOUS INJURY.

⚠ WARNING!

Indicates a hazardous situation or action which, if not avoided, could result in death or serious injury.

⚠ CAUTION!

Indicates a hazardous situation which, if not avoided, could result in minor or moderate injury.

NOTE: Notes provide additional information important to a procedure or component.

These safety warnings cannot eliminate the hazards they indicate. Observing safety precautions and strict compliance with the special instructions while performing the action or service are essential to preventing accidents.

Four commonly used safety symbols accompany DANGER, WARNING, and CAUTION boxes and the type of information each indicates:



This symbol points out important safety information that, if not followed, could endanger personnel and/or property.



This symbol represents the potential for an Explosion Hazard.



This symbol represents the potential for a Fire Hazard.



This symbol represents the potential for an Electrical Shock Hazard.



SAVE THESE INSTRUCTIONS. This manual contains important instructions that should be followed during installation of the generator set and batteries. The manufacturer suggests that these safety rules be copied and posted in potential hazard areas. Safety should be stressed to all installers, operators, potential operators, and service and repair technicians for this equipment.

The manufacturer cannot anticipate every possible circumstance that might involve a hazard. The warnings in this manual, and on tags and decals affixed to the unit, are not all-inclusive. If using a procedure, work method, or operating technique the manufacturer does not specifically recommend, ensure that it is safe for others. Also make sure the procedure, work method, or operating technique used does not render the generator unsafe.

- Despite the safe design of this generator, operating this equipment imprudently, neglecting its maintenance, or being careless can cause possible injury or death. Permit only responsible and capable persons to install, operate, and maintain this equipment.
- Parts of the generator are rotating and/or hot during operation. Exercise care near running generators.
- If this generator is used to power electrical load circuits normally powered by a utility power source, install a transfer switch. The transfer switch must effectively isolate the electrical system from the utility distribution system when the generator is operating. Failure to isolate an electrical system by such means will result in damage to the generator and also may result in injury or death to utility power workers due to backfeed of electrical energy.

⚠ DANGER!

 **Generators produce potentially lethal voltages. Ensure all steps are taken to make the generator safe before operation or service.**

1.3 — General Hazards

- For safety reasons, the manufacturer recommends that this equipment be installed, serviced, and repaired by an Authorized Service Dealer or other competent, qualified electrician or installation technician who is familiar with all applicable codes, standards, and regulations.
- Ensure that the generator is installed, operated, and serviced in accordance with the manufacturer's instructions and recommendations. Following installation, do nothing that might render the unit unsafe or in noncompliance.
- The engine exhaust fumes contain carbon monoxide, which can be DEADLY. If breathed in sufficient concentrations, carbon monoxide can cause unconsciousness or even death. For this reason, adequate ventilation must be provided. Exhaust gases must be piped safely away from any building or enclosure that houses the generator to an area where people, animals, etc. will not be harmed.
- Keep hands, feet, clothing, etc. away from drive belts, fans, and other moving or hot parts. Never remove any drive belt or fan guard while the unit is operating. Ensure that all guards, covers, and protective devices removed during maintenance or service are reinstalled.
- Adequate, unobstructed flow of cooling and ventilating air is critical to prevent buildup of explosive gases and to ensure correct generator operation. Do not alter the installation or permit even partial blockage of ventilation provisions, as this can affect safe operation of the generator.
- Keep the area around the generator clean and uncluttered. Remove any materials that could become hazardous.
- When working on this equipment, remain alert at all times. Never work on the equipment when physically or mentally fatigued.
- Inspect the generator regularly, and promptly repair or replace any worn or damaged components using only factory approved parts and procedures.
- Before performing any maintenance on the generator, always disconnect the battery cables to prevent accidental startup. Disconnect the cable from the battery post indicated by a NEGATIVE, NEG, or (–) first, then remove the POSITIVE, POS, or (+) cable. When reconnecting the cables, connect the POSITIVE cable first, the NEGATIVE cable last.
- Never use the generator or any of its parts as a step. Stepping on the unit can stress and break parts, and may result in exhaust, fuel, oil or coolant leaks.

1.4 — Electrical Hazards

- All generators produce dangerous electrical voltages and can cause fatal electrical shock. Utility power delivers extremely high and dangerous voltages to the transfer switch as well as the generator when it is in operation. Avoid contact with bare wires, terminals and other connections. Ensure all covers, guards, and barriers are in place, and that they are properly secured and/or locked before operation. If work must be done around an operating unit, stand on an insulated, dry surface to reduce potential shock hazard.
- Do not handle any kind of electrical device while standing in water, while barefoot, or while hands or feet are wet. DANGEROUS ELECTRICAL SHOCK MAY RESULT.

- If it is necessary to stand on metal or concrete while installing, operating, servicing, or repairing this equipment, lay down a dry wooden platform and cover with insulated mats before beginning.
- Verify that the generator is properly grounded.
- Wire gauge sizes of electrical wiring, cables, and cord sets must be adequate to handle the maximum electrical current (ampacity) to which it will be subjected.
- Before installing or servicing equipment, verify that all power voltage supplies are positively turned off at their sources. Failure to do so can result in hazardous and possibly fatal electrical shock.
- Connecting this unit to an electrical system normally supplied by an electric utility is by means of a transfer switch so as to isolate the generator electric system from the electric utility distribution system when the generator is operating. Failure to isolate the two electric system power sources from each other by such means will result in damage to the generator and may also result in injury or death to utility power workers due to backfeed of electrical energy.
- Generators installed with an automatic transfer switch will crank and start automatically when NORMAL (UTILITY) source voltage is removed or is below an acceptable preset level. To prevent automatic startup and possible injury, disable the automatic start circuit (battery cables, etc.) before working on or around the unit. Place a “DO NOT OPERATE” tag on the generator control panel and on the transfer switch.
- In case of accident caused by electric shock, immediately shut down the source of electrical power. If this is not possible, attempt to free the victim from the live conductor. AVOID DIRECT CONTACT WITH THE VICTIM. Use a nonconducting implement, such as a dry rope or board, to free the victim from the live conductor. If the victim is unconscious, apply first aid and get immediate medical help.
- Do not wear jewelry when working on this equipment. Jewelry can conduct electricity resulting in electric shock, or may get caught in moving parts resulting in injury.

1.5 — Fire Hazards

- Keep a fire extinguisher near the generator at all times. Keep the extinguisher properly charged and be familiar with its use. Direct any questions to the local fire department.

NOTE: DO NOT use any carbon tetra-chloride type fire extinguishers. These fire extinguishers emit toxic fumes and the liquid can damage wiring insulation.

1.6 — Explosion Hazards

- Properly ventilate the room or building housing the generator to prevent buildup of explosive gas.
- Do not smoke around the generator. Immediately wipe up any fuel or oil spills. Ensure that no combustible materials are left in the generator compartment, or on or near the generator, as FIRE or EXPLOSION may result. Keep the area surrounding the generator clean and free of debris.
- All types of fuels are potentially FLAMMABLE and/or EXPLOSIVE and must be handled with care. Inspect the fuel system frequently and correct any leaks immediately. Be sure fuel supply lines are properly installed, purged, and leak tested before placing the generator set into service.

1.7 — Standards Index

Be sure the generator set is in strict compliance with all applicable local, state, and federal laws, codes, and regulations pertaining to such installations. Always use the current version or edition of the applicable law, code, and regulation as it applies to the local jurisdiction. In the absence of pertinent local laws and standards, use the following published materials as a guide.

1. National Fire Protection Association (NFPA) 70: The National Electric Code (NEC)*
2. NFPA10: Standard for Portable Fire Extinguishers*
3. NFPA 30: Flammable and Combustible Liquids Code*
4. NFPA 37: Standard for Stationary Combustion Engines and Gas Turbines*
5. NFPA 54: National Fuel Gas Code*
6. NFPA 58: Standard for Storage and Handling of Liquefied Petroleum Gases*

7. NFPA 68: Standard on Explosion Protection by Deflagration Venting*
8. NFPA 70E: Standard for Electrical Safety in the Workplace*
9. NFPA 211: Standard for Chimneys, Fireplaces, Vents, and Solid Fuel Burning Appliances*
10. NFPA 220: Standard on Types of Building Construction*
11. NFPA 5000: Building Code*
12. International Building Code**
13. Agricultural Wiring Handbook***
14. ASAE EP-364.2 Installation and Maintenance of Farm Standby Electric Power****

This list is not all inclusive. Check with the Authority Having Local Jurisdiction (AHJ) for any local codes or standards which may be applicable to the jurisdiction where the generator is installed. The above listed standards are available from the following internet sources:

* www.nfpa.org

** www.iccsafe.org

*** www.rerc.org Rural Electricity Resource Council; P.O. Box 309; Wilmington, OH 45177-0309

**** www.asabe.org American Society of Agricultural & Biological Engineers; 2950 Niles Road; St. Joseph, MI 49085

Section 2 Installation Planning

⚠ DANGER!



Connecting this generator to an electrical system normally supplied by an electric utility shall be by means of a transfer switch, so as to isolate the electric system from the utility distribution system when the generator is operating. Failure to isolate the electric system by these means will result in damage to the generator and may also result in injury or death to utility workers due to backfeed of electrical energy.

NOTE: Only authorized dealers or qualified, competent installation contractors or electricians thoroughly familiar with applicable codes, standards and regulations should install this standby electric power system. The installation must comply strictly with all codes, standards and regulations pertaining to the installation.

2.1 — Protector Pre-Order Checklist

- The local fire marshal has confirmed that the generator must be located a minimum of _____ feet from a house or other structure.
NOTE: Generac recommends a minimum clearance of five feet from a combustible surface Per NFPA 37, Section 4.1.4.
- The local AHJ has advised me regarding the requirements for electrical and/or building permits, as well as those regulations relating to emissions and fuel storage.
- I have been advised of the local requirements for construction of a concrete base pad, and whether anchoring requirements are needed for installation on a flood plain.
- I have confirmed with the appropriate authorities that the generator must be located a minimum of _____ feet from a property line.
- I have been advised whether the local fire marshal (or other third party) is required to be present at start up.
- I have confirmed that the installation site is applicable to optional standby only and does not require an NFPA 110 capable generator.

2.2 — Unit Drawings

2.2.1— Installation Drawings

Installation drawings show weights, dimensions, clearances, exhaust details, connection locations, wiring stub-ups, lifting locations, and other information. Use the unit specific installation drawings when designing a site installation plan. Thoroughly read the NOTES section of each drawing for important details.

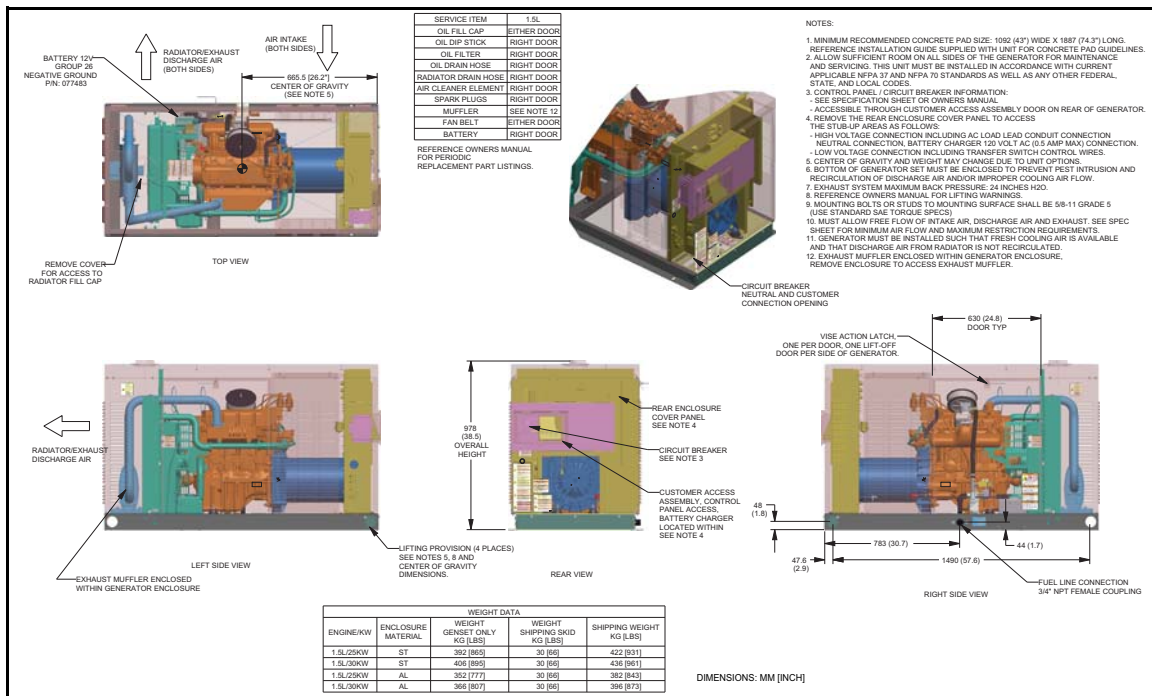

Figure 2-1. Typical Installation Drawing

2.2.2— Wiring Diagrams

Wiring and schematic diagrams show the connection points for control wiring, load wiring, and any service power supply required for battery chargers, block heaters, etc. Always use the unit specific wiring diagrams during planning and installation.

2.3 — Receiving

2.3.1— Receiving and Unpacking

When applicable, handle shipping cartons and crates with care to avoid damage. Store and unpack cartons with the correct side up, as noted by the label on the shipping carton.

2.3.2— Inspection

Carefully inspect the generator set and all contents of cartons for any damage that may have occurred during shipment. See the shipping documentation for any provisions or guidance when damage is incurred. Correct all damage or deficiencies before installation of the generator set.

2.4 — Storage Before Installation

2.4.1— Long Term Storage

If the unit is to be stored (or installed and not started-up) for six months or more, preserve in accordance with the manufacturer’s instructions. Contact the local Authorized Service Dealer to obtain the Long Term Preservation and Storage Manual (Part No. 0G4018) and the Preservation Checklist (Part No. 0G4018A).

2.4.2— Short Term Storage

If the unit is to be stored (or installed and not started-up) for less than six months, proceed as follows:

- All units are provided with an enclosure.

- Place the unit on a smooth flat surface. Do not leave unit on the shipping pallet, as it leaves the bottom open for entry of dirt, debris, insects, rodents, etc.
- If applicable, cover any exhaust system openings.
- Leave plastic plugs in fuel connection points.
- Use anti-rodent plugs and other enclosure features to prevent entry of birds, small animals, and foreign objects.

2.5 — Lifting

⚠ WARNING!



When lifting or hoisting equipment is used, be careful not to touch any overhead power lines. Generators that weigh more than 900 pounds require proper tools, equipment, and qualified personnel to be used in all phases of handling and unpacking.

To ensure personal safety and prevent damage to the unit, use only properly sized equipment intended for safe rigging, lifting and moving of heavy machinery.

Use a spreader bar to prevent damage to the unit. **Failure to use a spreader bar will result in scratches and damage to painted surfaces.**

Installation drawings show the lifting points for rigging and lifting purposes. Always attach lifting and rigging devices at the designated points only. Do not use the lifting points of the engine or alternator to move the generator set. See Figure 2-2.

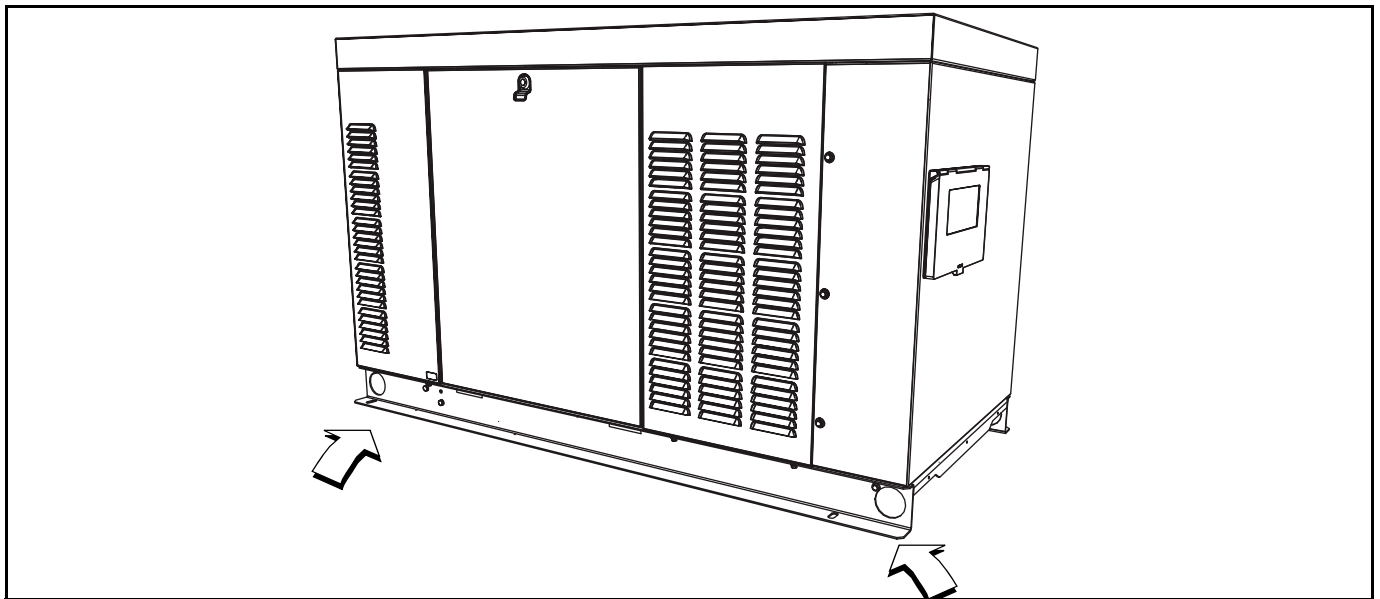

**Figure 2-2. Lifting Points (Four Places)
C1 Enclosure shown (22/25/27/30 kW)**

2.6 — Generator Location

Locate the generator set so that it is readily accessible for maintenance, repair, and firefighting purposes. Comply with code requirements for minimum distance from combustible walls and building openings.

2.6.1— General Location Guidelines

Consider the following:

- The supporting structure must be adequate for the generator set and its accessories.

- Be sure the site is clean, dry, not subject to flooding, and provided with adequate drainage in the event of heavy rains.
- Be sure the location permits noise and vibration to be effectively isolated.
- Verify that the site provides easy access to the generator set for maintenance, repair, and firefighting purposes.
- Keep a minimum of five (5) feet of clearance around each side of the generator set to facilitate service or maintenance.
- Be sure the location permits engine exhaust gases to be safely evacuated from inhabited or occupied areas. Consider the direction of prevailing winds to prevent exhaust gases from being carried back to the engine area or to the fresh air intake vents of nearby buildings.
- The site must allow for the provision of an adequate fuel supply.
- Be sure the location permits sufficient air flow for cooling and ventilation. Consider the proximity of any walls, fences, or other noise abatement or security barriers. Do NOT face the radiator discharge end of the enclosure into the prevailing wind.
- Consider cold weather kit options and accessories for the generator in cold weather locations.
- Verify that the unit is securely fastened to the mounting pad to prevent movement caused by vibration.
- Verify that all electrical connections have flexible sections to isolate vibration.
- Verify that the fuel pressure and pipe is sized correctly and that it has the appropriate flex hose.

NOTE: Failure to comply with the location guidelines can result in damage to the generator or surrounding area and may cause the warranty to be suspended or voided. Extra repair labor or equipment may not be covered under the warranty if service access is difficult or restricted.

2.6.2— Weather Considerations

Consider local weather conditions during installation. There are various accessories available to ensure fast, reliable starting and operation regardless of local climatic conditions. Optional cold weather kits make starting of the engine more dependable and reliable.

2.7 — Accessories

The following product accessories are available. Contact a Dealer for additional information.

1. Scheduled Maintenance Kit
2. Cold Weather Kit
3. Extreme Cold Weather Kit
4. Mobile Link
5. Mobile Link Harness Adapter Kit*
6. Wireless Local Monitor
7. Wireless Local Monitor Harness Adapter Kit*
8. Smart Management Module
9. Emergency Stop Switch
10. Base Plug Kit
11. Touch-Up Paint Kit

*Required for liquid-cooled applications

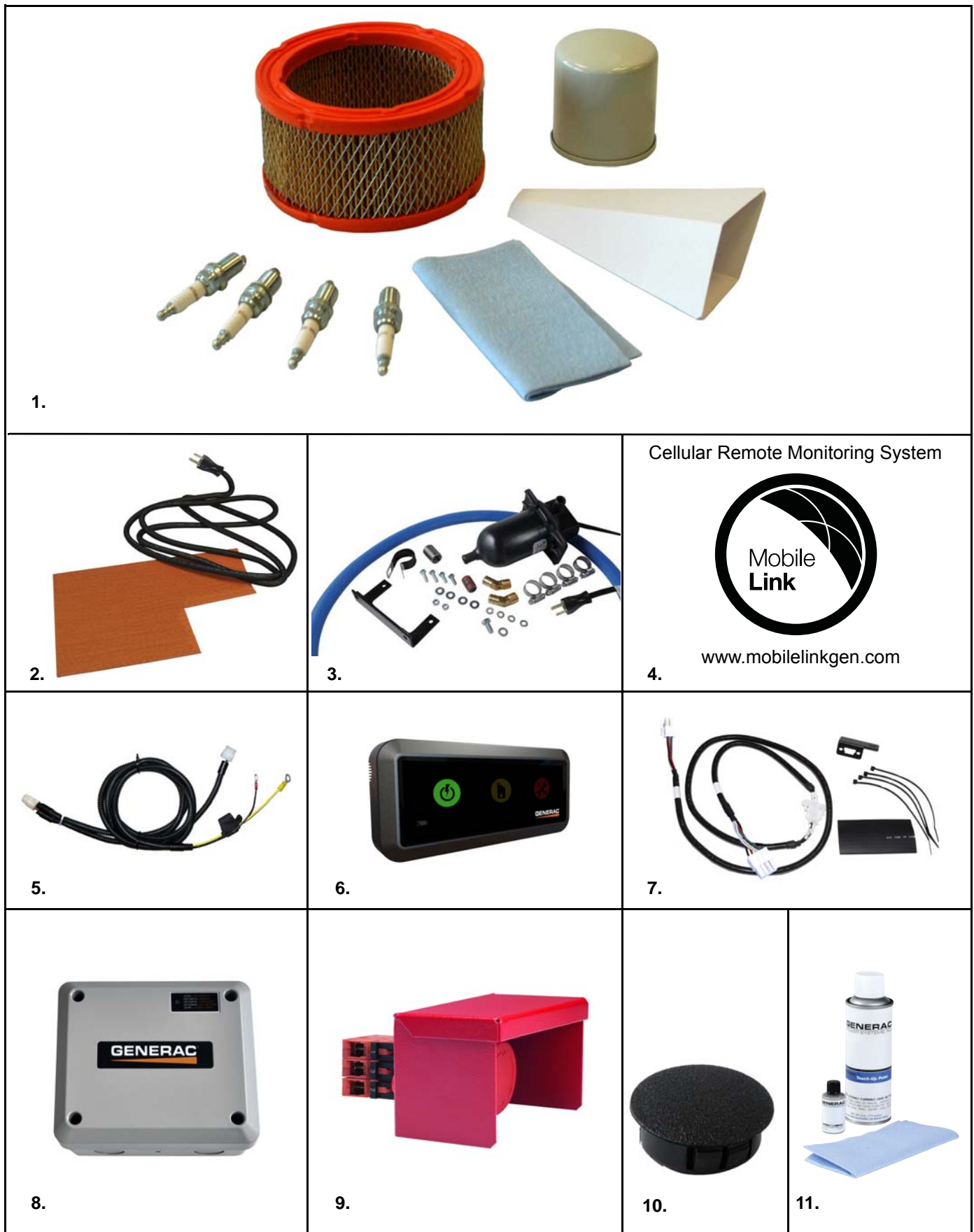

Figure 2-3. Product Accessories

This page intentionally left blank.

Section 3 Foundations & Mounting

3.1 — Generator Foundations

Install the generator set on a concrete pad or base slab able to support its weight and accessories. A proper foundation is needed to resist dynamic loading and reduce transmitted noise and vibration. The exact composition of the mounting pad must follow standard engineering practices for the required loading and application. **Securely fasten the generator set to the foundation using suitable grade, size and style fasteners.** Holes are provided in the base frame for this purpose.

3.1.1— Concrete Pad

Follow all federal, state, and local codes when designing a concrete pad or base slab.

Seat the concrete pad on a prepared solid subsurface and use appropriate reinforcing bar or expanded wire mesh. A common specification calls for 2500 psi concrete reinforced with 8 gauge wire mesh or number 6 reinforcing bars on six (6) inch centers.

3.1.2— Dimensions

Extend the concrete pad beyond the frame of the unit at least six (6) inches. This provides a mounting surface for fuel line support, as well as space for maintenance and repair.

The base pad must be:

- Capable of supporting 125% of the unit wet weight for single unit applications.
- Flat and level to within 1/2 inch.
- Capable of withstanding severe torque reactions.

To calculate the depth of the concrete pad, the following formula may be used:

$$\text{Depth of Base} = \frac{W}{150 \times B \times L}$$

W = Total wet weight of generator set in pounds (kg)

150 = Density of the concrete (pounds per cubic foot)

2400 = Density of concrete (kilograms per cubic foot)

B = Foundation width in feet (meters)

L = Foundation length in feet (meters)

Suggested mixture of concrete (by volume) is 1:2:3 of cement, sand, and aggregate with a maximum four inch (100mm) slump with a 28 day compression strength of 3000 psi (200 MPa).

3.1.3— Unit Clearance

Verify that the site provides easy access to the generator set for maintenance, repair, and firefighting purposes. Keep a minimum of 5 feet of clearance around each side of the generator set to facilitate service or maintenance.

3.1.4— Stub Up Area

For load conduit, auxiliary power conduit (high voltage), and control wiring conduit (low voltage), see the installation drawings for the location and dimensions of the stub up areas. See Figure 3-1.

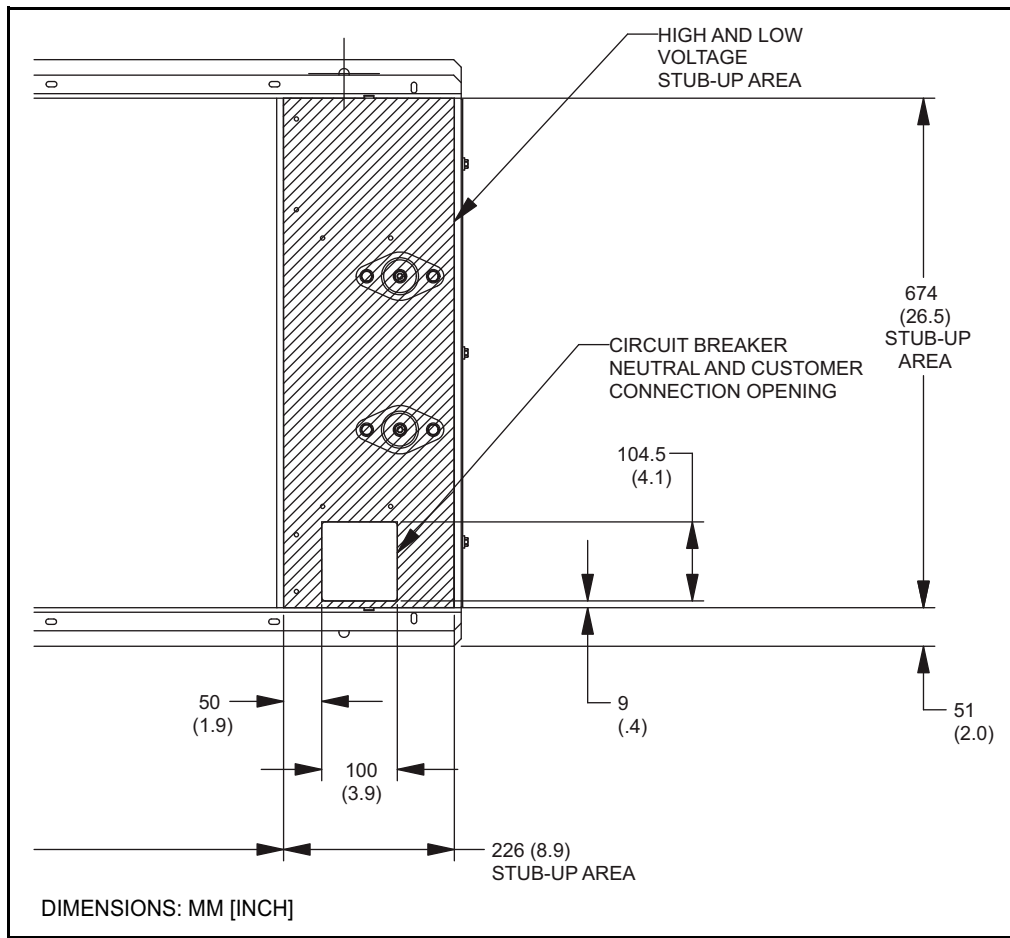

Figure 3-1. Typical Installation Drawing Stub Up Detail

3.2 — Mounting

3.2.1— Fixed Foundation

Use mounting holes in the base frame to fasten the unit to the foundation. Always use hardware of a suitable grade, size and style.

3.2.2— Connections

All electrical connections must have flexible sections where they connect to the unit to isolate vibration. Properly support and secure all piping before installing the flexible connection.

3.2.3— Combustible Floor and Roof Protection

If the generator set must be installed on any combustible floor or roof, comply with the following rules:

- Place a layer of non-combustible insulation, followed by a layer of sheet metal, beneath the unit's mounting base rails.
- Both the layer of insulation and the sheet metal must extend beyond the engine-generator base, to a distance of at least six (6) inches (15.25cm) on all sides. See Figure 3-2.

For rooftop or building structure mounting, it is recommended that spring isolators be installed between the engine frame and the mounting system. A minimum of 6 isolators are required and must be located at the front and rear cross members and center of the frame.

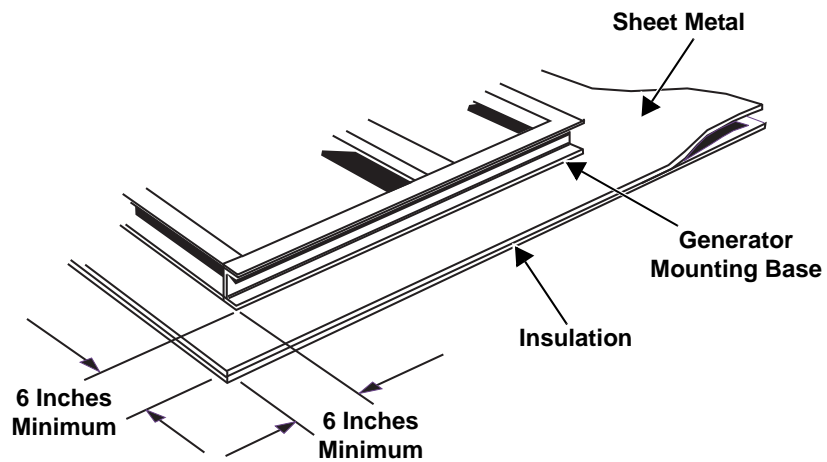

Figure 3-2. Combustible Floor and Roof Protection.

Since the entire bottom of the genset is now exposed, it should be covered with a sheet metal plate to keep out small animals and protect the integrity of the internal parts of the genset. Genset movement is more intense with spring isolation, therefore flexible connections for the fuel and the electrical conduits are also required.

NOTE: Consult local building codes which may vary

This page intentionally left blank.

Section 4 Ventilation System

4.1 — General

Adequate and unobstructed flow of cooling and ventilating air is critical to prevent buildup of explosive gases and to ensure safe generator operation. Do not alter the installation or permit even partial blockage of ventilation provisions. Keep area around the generator clean and uncluttered, and remove any materials that may pose a hazard.

4.2 — Outdoor Installation Only

The unit is for outdoor installation only. The installation design must ensure that there are no obstructions at any of the air intakes that may impede intake airflow.

This page intentionally left blank.

Section 5 Gaseous Fuel Systems



Gaseous fuels, such as LP and natural gas, are highly volatile and their vapors are explosive. LP gas is heavier than air and will settle in low areas. Natural gas is lighter than air and will settle in high areas. Even the slightest spark can ignite these fuels and cause an explosion.

5.1 — General

Consult a local gas distributor or licensed plumber/installer when installing a gaseous fuel supply system or refer to information published by various federal agencies. For a list of some of these publications, see Subsection 1.7.

5.1.1— Fuel System Conversion

Industrial units come from the factory configured and EPA certified with the fuel system ordered. Any one of the following gaseous fuel systems may be installed:

- Natural Gas (NG)
- LP-Vapor Withdrawal

To convert to a different fuel (for example, from NG to LP-Gas Vapor), see the owner's manual or an independent authorized service dealer.

5.2 — Gaseous Fuel Properties

5.2.1— Natural Gas

Natural gas is lighter than air. It is found in the gaseous state at normal ambient temperatures and pressures. It is highly explosive and can be ignited by the slightest spark. For this reason, fuel lines must be free of leaks and adequate ventilation is absolutely essential. Local fuel/gas codes dictate the maximum pressure under which natural gas can be delivered to a site or structure. The supply pressure from the utility meter/regulator is usually not the same as that required by the generator set, so a separate primary regulator providing the correct pressure and volume of fuel to the generator set is required. If the local utility source pressure is **less** than that required by the generator, it is up to the local utility to provide the volume of gas at the required pressure.

5.2.2— Propane Vapor (LPV)

Liquefied Petroleum gas is heavier than air. The gas vapors are explosive and can be ignited by the slightest spark. LP Vapor is supplied by liquid propane stored in tanks. Propane exists in its liquid form at or below its boiling point (-44° F) as well as when it is stored under pressure. LP tank pressure is dependent on the ambient temperature and the liquid volume in the tank, and can be over 200 psi. A first-stage regulator at the tank reduces the gas pressure to a lower line pressure value. This line pressure is then reduced to the correct operating pressure and volume for the generator set through the use of a second-stage regulator.

5.3 — Gaseous Fuel Systems

5.3.1— Natural Gas System

The local utility will usually provide the piping (meter and pressure regulator) from the main distribution line to the generator site. The local utility is also responsible for providing gas at sufficient volume and pressure to operate the primary regulator, so that the regulator can provide the correct volume of gas at the required pressure to the generator.

From the primary regulator, gas flows to the generator connection point, which is the end of the manufacturer supplied flexible fuel line. The flexible fuel line can be connected directly to the generator connection point (perpendicular to the frame rail), or by an elbow and short nipple to the frame rail itself (to run parallel to the frame rail). The nipple and elbow used must be the same pipe size as the flexible fuel line and generator connection point. Install a flexible fuel line

between the rigid supply piping and the gas connection at the generator, and must be installed straight without bends or kinks. The primary regulator outlet and the generator connection point must be sized correctly to provide the generator with the required volume and pressure when it is operating at 100% of its rated load.

On the generator the unit mounted regulator (it may be either a demand regulator or a pressure regulator) and its associated shutoff valves control the flow and pressure to the unit for proper operation. The fuel pressure required for the generator to operate is always measured at the inlet of the unit mounted regulator. For the location of the pressure test connection, see Subsection 5.6.1. The supply pressure and volume must meet the requirements described in the unit specification sheet. If specifications are not met, the generator will not operate properly and will probably display symptoms, such as hard starting, rough running, inability to carry load, and erratic operation.

NOTE: Gas pressure from the primary regulator (supplied by the installing contractor) to the generator's fuel shutoff valve should be between 5-14 inches W.C.

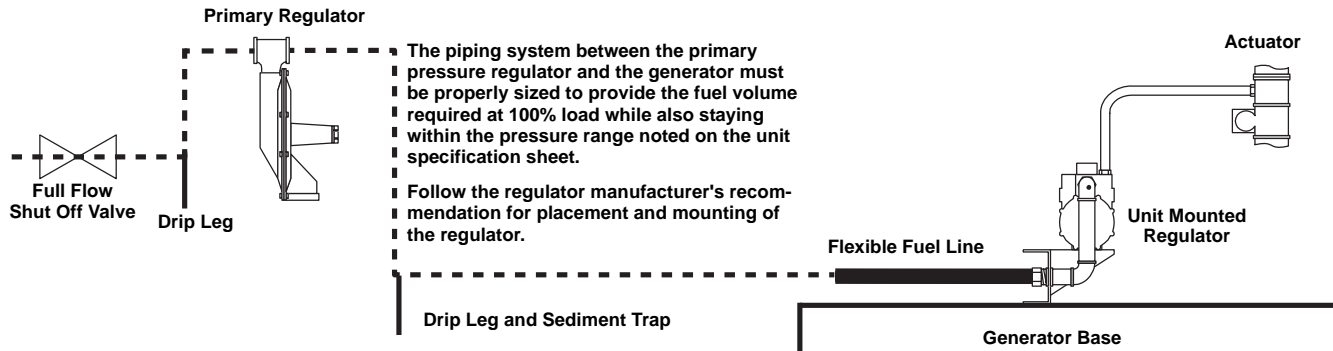

Figure 5-1. Typical NG Fuel System

5.3.2— LP-Vapor Withdrawal System

This type of system uses the vapors formed above the liquid fuel in the supply tank. The maximum tank fill capacity is 80% and a minimum of approximately 20% of the tank capacity is needed for fuel expansion from the liquid to vapor state. Gas pressure and volume requirements for an LP-Gas vapor system at the connection point of the generator are listed on the unit specification sheet.

Pressure regulation for vapor withdrawal systems is typically a two-step process. First, by reducing the high tank pressure to a lower line pressure with a first-stage regulator, then reducing the line pressure to the pressure required by the unit with a second-stage regulator. Both regulators and the associated system piping and valves need to be sized correctly to provide the generator with the required volume and pressure of fuel at the generator connection point.

NOTE: Gas pressure from the primary regulator (supplied by the installing contractor) to the generator's fuel shutoff valve should be between 5-14 inches W.C.

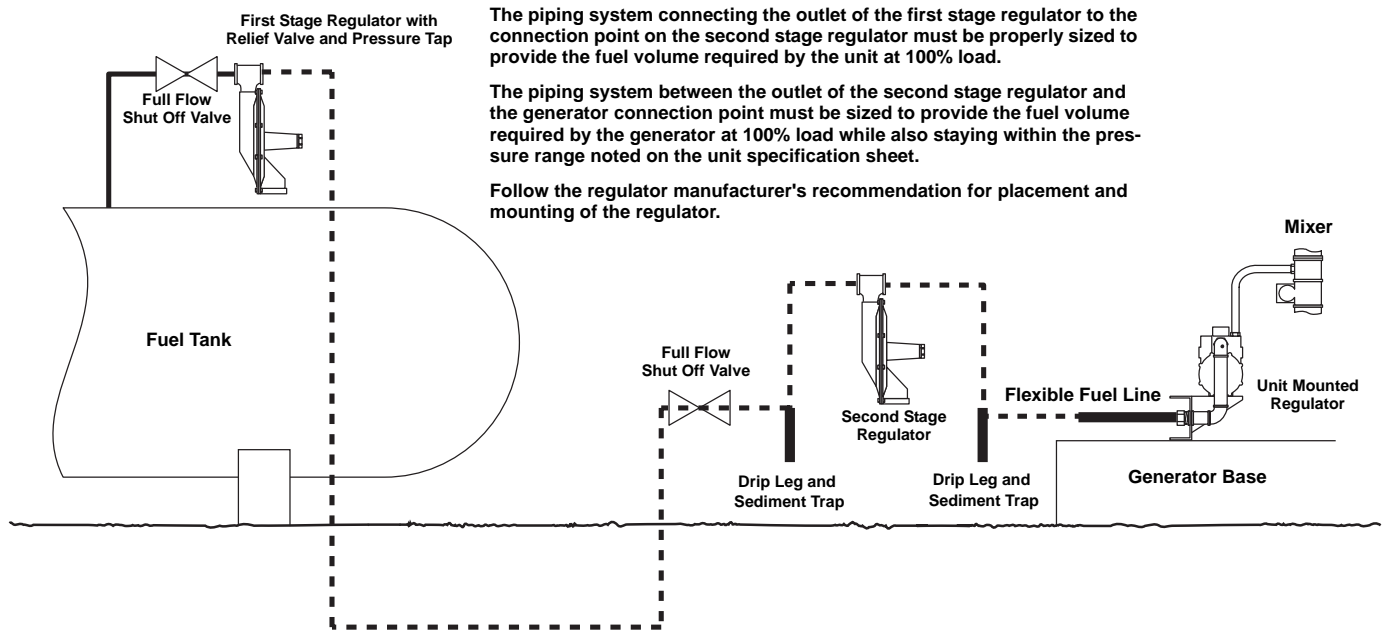

Figure 5-2. Typical LP-Vapor Withdrawal Fuel System

5.3.3— Drip Leg

Install at least one drip leg (sediment trap) before the unit to separate sediment, debris, and condensation from the gas flow. A drip leg is also recommended at the bottom of a vertical pipe run and after each change in direction. Drip legs protect downstream equipment, such as the primary or second stage pressure regulators, from clogging and contamination. Some installations and/or jurisdictions may require no drip legs, or multiple drip legs. Consult the local AHJ for requirements.

5.4 — Fuel Pressure Regulators

5.4.1— General

One of the most common causes of a generator set not operating properly is improper sizing and installation of the gaseous fuel supply system between the meter (utility source) and the generator connection. The fuel supply system consists of a primary regulator to regulate the flow and volume from the source (utility supply) to the generator, and all of the associated piping, fittings, and shutoff valves, both upstream (feeding the main meter/regulator) and downstream (between the meter and primary regulator), which connect the fuel source to the connection point on the generator. The fuel supply system must be capable of supplying the correct volume of fuel within the correct pressure range to the connection point on the generator. The volume of fuel and operating pressure required are listed in the technical specifications for the applicable generator. Fuel pressure at the unit must remain within the specified operating range and not drop below the minimum pressure specified.

5.4.2— Definitions

The following definitions are provided for use in this manual.

Table 5-1. Definitions

Term	Description
Allowable Pressure Drop	The design pressure loss in the system under maximum probable flow conditions, from the point of delivery to the inlet connection of the generator set, shall be such that the supply pressure at the generator is greater than or equal to the minimum pressure required by the generator at its full load capacity.
Authority Having Jurisdiction (AHJ) (NFPA-54)	An organization, office, or individual responsible for enforcing the requirements of a code or standard, or for approving equipment, materials, an installation, or a procedure.
Cubic Foot (ft ³) of Gas (NFPA-54)	The amount of gas that would occupy 1 ft ³ when at a temperature of 600° F saturated with water vapor and under a pressure equivalent to 30 in. w.c.
Generator Connection Point	The connection point for the fuel supply system to the generator set is the end of the manufacturer supplied flexible hose fitting which connects to the fitting on the base frame of the generator. An elbow and short nipple can be incorporated to allow the flexible hose to be positioned parallel to the unit base frame. The size of the connection point on the base frame is shown in each unit's installation drawing; the size of the flexible hose (and any elbow and nipple) must be equal to or larger than this connection point. The flexible hose must be installed straight without bending, twisting or kinking.
psi & psig	Measure of pressure in pounds per square inch and pounds per square inch gauge.
Inches of Water Column (in.w.c.)	Measure of pressure in inches of water column (in. w.c.). 14 in. w.c. = approximately 0.5 psi.
Primary Regulator	A pressure regulator installed between the service regulator (NG) or first-stage regulator (LP-Gas vapor) sized to provide the pressure and volume required by the generator at its full rated load capacity.
Regulator (for LP-Gas vapor)	
First-Stage Regulator	A pressure regulator for LP-Gas vapor service designed to reduce pressure from a container to 10.0 psig or less.
High-Pressure Regulator	A pressure regulator for LP-Gas liquid or vapor service designed to reduce pressure from the container to a lower pressure in excess of 1.0 psig.
Second-Stage Regulator	A pressure regulator for LP-Gas vapor service designed to reduce first-stage regulator outlet pressure to 14 in. w.c. or less. For generator set purposes, this is also referred to as the Primary Regulator.
Regulator (for NG fuel)	
Pressure Regulator	Device placed in a gas line for reducing, controlling, and maintaining pressure in downstream piping
Service Regulator	A pressure regulator installed by the servicing gas supplier to reduce and limit the service line gas pressure to delivery pressure.

5.4.3— Best Practices

These are the manufacturer recommended best practices for configuring and sizing fuel supply piping to generators. These best practices have been developed specifically for the manufacturer's product and may not represent conventional gaseous fuel system sizing methods, particularly those used frequently with low volume appliance installations. Compliance with these best practices will help to ensure the generator set engine will operate properly under dynamic conditions.

- The minimum distance from the primary pressure regulator outlet to the generator connection point will be covered in the regulator manufacturer's installation instructions. Do not connect the pressure regulator directly to the flexible fuel line on the generator. The piping between the primary pressure regulator and the connection point on the generator acts as a reservoir (accumulator) which stores gas and, therefore, can minimize or maximize the changes in delivery pressure that the generator sees during cranking and load changes.

- The required fuel pressure to the unit is measured before the fuel shutoff solenoids at the inlet to the unit mounted regulator. A 1/8 inch pipe port in the pressure regulator body, or in the piping just before the pressure regulator, is provided for this purpose. See Subsection 5.6.1.
- Seasonal supply pressure changes to the primary pressure regulator can affect the proper operation of the generator. The fuel supply pressure to the unit must remain within the specified operating parameters as stated in the unit specification sheet. Contact the local utility to find out what can be done to correct seasonal changes.
- Use sediment traps.
- The generator set must have its own dedicated fuel supply. Do not connect any other loads to the outlet of the primary pressure regulator.

For LP-Vapor systems, due to the nature of the conversion process from LP liquid to LP vapor, consider the following:

- The vaporization rate of a given LP tank is dependent on the liquid level in the tank (wetted surface area), the ambient temperature around the tank, and relative humidity.
- When ambient temperatures are below 40° F, engine fuel consumption is high, and sufficient humidity is present, condensation can occur resulting in frosting of the tank at the liquid level. This condition can lead to a reduced rate of vaporization. See the LP tank sizing section for more information.

5.4.4— Operating Fuel Pressure

The unit specification sheet lists the operating fuel pressure range, as well as the 100% load fuel consumption rate. The pressure range is the minimum and maximum acceptable pressures for proper operation of the unit under all operating conditions. The maximum fuel system pressure drop at each condition, that is, static, cranking, running at no load, and running at full load, is 1-2 in. w.c. as measured at the primary fuel pressure regulator. For definitions of each condition, see Subsection 5.6.2.

5.4.5— Engine Fuel Consumption

The volume of gaseous fuel consumed at various loads is listed in the unit specification sheet. Both Natural Gas and LP-Vapor values are provided in Cubic Feet per Hour (CFH). International units of measure are also provided.

Use the following formulas if it becomes necessary to convert CFH to BTUs per Hour:

- **Natural Gas:** $CFH \times 1000 = BTU \text{ per hour}$

- **LP-Vapor:** $CFH \times 2520 = BTU \text{ per hour}$

5.4.6— Fuel Pressure Regulator Sizing

Fuel pressure regulators are designed to automatically adjust flow to meet downstream demand at a required pressure. The typical regulator installed as the primary regulator for a generator set is of the direct acting, internally registered design. Direct acting means that the pressure sensing element acts directly to open the valve and control the flow to the load while maintaining the desired pressure. The pressure sensing element is typically a diaphragm which is opposed by a combination of spring pressure and atmospheric pressure. The valve is the restricting element and consists of some type of variable restriction (cone, poppet, disc) which closes against a fixed seat. Internal registration means that the pressure used for sensing comes from within the valve body, usually through a passage from the secondary side (outlet) to the sensing diaphragm.

The primary regulator must be sized to provide the required flow at the rated pressure to the generator at its full load capacity. The generator fuel consumption values and required operating pressures are listed in the unit specification sheet.

The manufacturer recommends that the primary pressure regulator be sized for at least 110% of the generator's required fuel consumption at 100% load, and that the regulator provide no more than a 1-2 inch w.c. pressure drop at each operating condition, that is, static, cranking, running at no load, and running at full load.

Various regulator manufacturers provide sizing tables, flow capacity, pressure drop tables, and distributors who will help size a regulator correctly to a system.

5.4.7— Recommended Fuel Pressure Regulators

Use only direct acting fuel pressure regulators, such as those made by **Fisher®** or **Maxitrol®** or any other listed regulator manufacturer.

5.4.8— Primary Fuel Pressure Regulator

The following are the recommended “best practices” with regard to specifying, sizing, and installing the primary fuel pressure regulator.

1. Verify that the regulator:
 - Is sized to have a fuel flow delivery rating (CFH) at least 10% greater than the 100% rated kW fuel consumption requirement of the generator.
NOTE: The recommended selection for orifice diameters is to use the smallest orifice that will still provide a CFH fuel flow rate at least 1.1 times greater than the required full load CFH rating of the generator set.
 - Is approved for a mechanized engine application. A standard HVAC type regulator or standard appliance regulator is prohibited.
 - Has an accuracy rating of 1% or less and/or have a maximum allowable pressure droop rate of 1-2 inches w.c.
NOTE: Droop is the reduction of outlet pressure experienced by pressure-reducing regulators as the flow rate increases. It is stated as a percent, in inches of water column, or in pounds per square inch, and indicates the difference between the outlet pressure at low flow rates and the outlet pressure at the published maximum flow rate. Droop is also called offset or proportional band. For proper generator operation, a maximum of 1-2 in. w.c. droop is required at each operating condition, that is, static, cranking, running at no load, and running at full load.
 - Has a spring rating within the range of 5 to 14 inches w.c.
2. Be sure that the generator has a dedicated fuel supply which is not shared with any other appliances (furnace, water heaters, ranges, etc.).
3. Check the inlet pressure measured at the regulator body inlet connection when the regulator appears unable to pass the published flow rate. Supply piping up to the regulator can cause significant flowing pressure losses.
4. Be sure the regulator is flowing at least five percent of the normal operating flow when adjusting the pressure set point.
5. Expect approximately a one degree drop in gas temperature for every 15 psid (differential) across the regulator due to the natural refrigeration effect.
NOTE: Freezing is often a problem when the ambient temperature is between 30° and 45° F (-1° and 7° C), particularly with LP-V systems.
6. Point vents down to help avoid the accumulation of water condensation or other materials in the spring case.
7. Keep vents open. Do not use long, small diameter vent lines. Follow the rule-of-thumb: use the next nominal pipe size for every ten feet of vent line, and use three feet of vent line for every elbow in the line.
8. The connection point on the generator is the end of the manufacturer supplied flex hose. The flex hose is the same size as the connection point on the generator frame rail (see installation drawings). It is permissible to install one elbow (90°) and a short nipple between the flex hose and frame rail connection point to allow the flex hose to parallel the frame rail for installation purposes.

5.5 — Pipe Sizing Considerations

5.5.1— General

Consult a local gas distributor or licensed installer when sizing and installing the piping for any gaseous fuel supply system. When using a local gas distributor or installer, be sure they have the proper documentation to support their recommendations. The fuel system requirements and best practices conveyed in this manual must be provided to the representative responsible for sizing the fuel system. The final test of the system is measuring the fuel pressure as described in Subsection 5.6.1. If the pressure requirements are not met, then the fuel supply system is not correct.

There are several pipe sizing programs available for use on the Internet and from various manufacturers. If used it is highly recommended that the minimum pressure drop value always be used (0.5 inches w.c or less). This will ensure that the piping system is sized correctly to handle the generator set volume at full load, and during cranking and load transients, while also remaining above the minimum operating pressure.

The following general rules apply to piping of gaseous fuel systems:

- Use black iron piping or other approved gas line. Pipe must be rigidly mounted and protected against vibration.
- Install the supplied or recommended length of flexible hose between the generator connection point and the rigid supply piping. Install the flexible hose straight without bends, twists or kinks. Do not install the flexible hose underground or in contact with the ground.
- Install a drip leg and sediment trap. (Consult local AHJ for requirements)
- Correctly size the piping to maintain the required supply pressure and volume under varying load conditions.
- Properly purge and leak test installed piping.
- Use an approved pipe sealant or joint compound on all threaded fittings to reduce the possibility of leakage.
- Make provision for a fuel shutoff valve near the unit. Verify that the fuel shutoff valve is installed correctly and works properly.
- Using suitable methods, check entire pipe run for leaks.

Table 5-2. Fuel Pipe Sizing for Natural Gas (NG)

Natural Gas 5" to 14" of Water Column						
Table values are maximum pipe run in feet.						
	Pipe Size (inches)					
kW	1 in	1.25 in	1.5 in	2 in	2.5 in	3 in
22	20	100	200	750	—	—
25	10	80	175	575	—	—
27	—	85	203	552	—	—
30	—	60	125	450	—	—
35-36	—	35	95	370	915	—
45	—	15	60	260	650	—
48	—	—	50	230	585	—
60	—	—	25	145	375	1100

Natural Gas
1 cubic foot = 1,000 BTU
1 therm = 100,000 BTU
Gas consumption = 13,000-16,000 BTU per kW/hr

Pressure
1 inch mercury = 13.61 inches water column
1 inch Water Column = 0.036 psi
3.5–14 inches water column = 0.126 psi to 0.50 psi

Note:

- Pipe sizing is based on 0.5" H₂O pressure drop.
- Sizing includes a nominal number of elbows and tees.
- Please verify adequate service and meter sizing.
- Tables based on black pipe.

Note: Size the fuel pipe to the sizing charts or to local codes. When installing other than Sch. 40 black pipe, please refer to the manufactures sizing charts.
The liquid-cooled generator is not a constant flow appliance, the fuel pipe was sized large enough to supply at least 125% of the generator BTU/hr rating.

Table 5-3. Fuel Pipe Sizing for Natural Gas (NG)

LP Vapor (LPV) 11" to 14" of Water Column					
Table values are maximum pipe run in feet.					
	Pipe Size (inches)				
kW	1 in	1.25 in	1.5 in	2 in	2.5 in
22	85	365	—	—	—
25	60	275	605	—	—
27	55	260	575	—	—
30	40	195	435	—	—
35-36	20	125	290	1030	—
45	—	82	195	725	—
48	—	70	165	620	—
60	—	45	115	445	1095

LP
LPG: 8.55 ft³/lb., 4.24 lbs./gal., 2500 btu/ft³
LPG: 36.3 ft³ = 1 gal.

Pressure
1 inch mercury = 13.61 inches water column
1 inch Water Column = 0.036 psi
11–14 inches water column = 0.396 psi to 0.50 psi

Note:

- Pipe sizing is based on 0.5" H₂O pressure drop.
- Sizing includes a nominal number of elbows and tees.
- Please verify adequate service and meter sizing.
- Tables based on black pipe.

Note: Size the fuel pipe to the sizing charts or to local codes. When installing other than Sch. 40 black pipe, please refer to the manufactures sizing charts.
The liquid-cooled generator is not a constant flow appliance, the fuel pipe was sized large enough to supply at least 125% of the generator BTU/hr rating.

5.5.2— Sizing LP Tanks for Vapor Withdrawal

The manufacturer recommends that the installer consult with a reputable LP supplier when sizing LP storage tanks and their associated pressure regulators and piping systems. Many factors come into play when working with LP in either its vapor or liquid form.

The operation of an LP-Vapor system depends on the vaporization of the liquid stored in the tanks. As the vapor above the liquid level is withdrawn the pressure in the tank decreases. This change in pressure causes the liquid to “boil” in order to restore the pressure equilibrium. The liquid in the tank uses the temperature difference between its boiling point (-44° F for Propane) and the outside temperature to extract enough heat to enable vaporization (boiling). Only the liquid in contact with the tank wall absorbs heat from the outside. The area of the tank where the liquid is in contact with the tank wall is referred to as the “wetted surface area”. Cold weather results in a reduced tank vaporization capacity because there is less heat energy available to boil off the liquid into vapor. The wetted surface area of the tank must be large enough to sustain the vaporization rate required by the generator. Depending on the relative humidity and the ambient temperature, frosting can occur on the outside of the tank when it is in use. This condition further inhibits the heat transfer required to sustain vaporization.

Several factors affect the rate of vaporization for LP tanks:

- The size of the tank (wetted surface area). As the wetted surface area decreases the rate of vaporization decreases.
- The lowest liquid level the tank will be allowed to reach (relates directly to the wetted surface area). The typical maximum fill level for LP tanks is 80%, and the lowest recommended operating level is 20%. This provides a volume equivalent to 60% of the tank capacity to be used to calculate run time. Most tank sizing tables provide the vaporization rate of the tank at the lowest allowable level (20%); any tank level above this point will have a higher vaporization rate.
- The lowest normal temperature expected. Typical tank tables provide vaporization rates at 40° F, 20° F, and 0° F. For temperatures below 0° F consult a reputable LP dealer for options.
- The mean relative humidity.

To size an LP tank for a desired run time the following information is required:

- The maximum vapor consumption of the generator (in BTU/hr) at 100% load. The specification sheet for the generator will list the fuel consumption rate, usually in cubic feet per hour. To convert CFH to BTU/hr, multiply by 2520.
- The fuel consumption rate in gallons per hour with the generator at 100% load. To convert CFH (propane vapor) to GPH, divide by 36.38. To convert BTU/hr to GPH, divide by 91502.
- The desired run time.
- The minimum operating temperature expected.

The most important thing to consider when sizing LP tanks for vapor withdrawal is the vaporization rate of the tank at the minimum temperature expected, and at the minimum fuel level the tank will be allowed to reach. The vaporization rates shown in Table 5-4 are based on the tank at 20% of its fill capacity.

1. Multiply the gallons per hour fuel consumption rate of the generator at 100% load by the longest run time expected/desired.
2. Determine the fuel consumption in BTU/hr with the generator at 100% load.
3. Determine the lowest expected operating temperature.
4. See Table 5-4. Using both the Minimum Operating Temperature and the Tank Vaporization Capacity columns, find the BTU/hr vaporization rate of the generator at 100% load that corresponds to the lowest expected operating temperature.
5. Look back at column 2, note the Available Tank Capacity. If it is greater than the total run time fuel consumption refer back to column 1- this is the correct size tank required. If it is less than the total run time fuel consumption, then go to the next larger tank size. Recheck the lowest operating temperature and the tank vaporization capacity.

Table 5-4. Vaporization Rates

Tank Capacity Total (gal) See Note 1	Available Tank Capacity (gal) See Note 2	Minimum Operating Temperature (° F)	Tank Vaporization Capacity (BTU/hr) See Note 3	Length (In.)	Diameter (In.)
250	150	40 20 0	507,600 338,400 169,200	94	30
325	195	40 20 0	642,600 428,400 214,200	119	30
500	300	40 20 0	792,540 528,360 264,180	119	37
850	510	40 20 0	1,217,700 811,800 405,900	165	41
1000	600	40 20 0	1,416,960 944,640 472,620	192	41
<p>Note 1: The minimum LP tank size is 250 gallons, unless unit calculations dictate use of a larger tank. Vertical tanks, which are measured in pounds, will not usually meet the minimum tank size (250 Gallons x 4.20 Pounds = approximately a 1050 pound vertical tank minimum).</p> <p>Note 2: The available tank capacity is approximately 60% of the total fill capacity. This is based on a maximum fill level of 80% and a minimum operating level of 20% (80%-20% = 60%).</p> <p>Note 3: The vaporization capacity shown is based on a tank level of 20%. This represents the smallest allowable wetted surface area of the liquid in the tank. As the liquid level goes up, the wetted surface area and the vaporization rate increases.</p>					

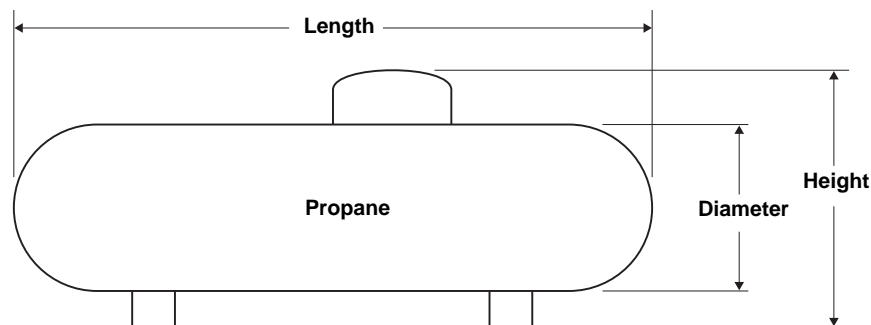

Figure 5-3. Typical Propane Tank Dimensions

NOTE: The minimum LP tank size is 250 gallons, unless unit calculations dictate use of a larger tank. Vertical tanks, which are measured in pounds, will not usually meet the minimum tank size (250 Gallons x 4.20 Pounds = approximately a 1050 pound vertical tank minimum).

Propane conversion figures:

- 36.38 ft³ = 90,500 Btu = 1 gal
- 1 lb = 21,500 Btu = 8.56 ft³
- 2500 Btu = 1 ft³

5.6 — Final Operating Test

A properly configured and sized fuel system provides the fuel volume and fuel pressure required for the generator set to operate correctly in all modes of operation. To confirm proper fuel system operation, a series of tests must be performed as further described below.

5.6.1— Gas Pressure Test Port Location

Using a suitable pressure gauge or water manometer, measure the gas pressure to the generator at a test port located before the fuel solenoid shutoff valve(s).

See A of Figure 5-4. On units using the demand type regulator(s), there may be a factory installed 1/8 inch pipe port in a tee fitting connected to the low pressure switch.

See B of Figure 5-4. If the unit has a low pressure switch without the tee, install a tee and plug between the low pressure switch and the test port on the regulator body using a suitable pipe dope. Use only the upper port on the regulator body, as it detects supply gas pressure even when the unit solenoid valve is closed. This allows static pressure to be measured, as well as pressure when cranking, while running at no load, and while running at full load.

See C of Figure 5-4. Factory installed at the test point, some units may be provided with a special test port plug known as a "Pete's Plug." The plug allows fuel pressure test readings to be taken quickly without leaving costly gauges installed in the line.

Use the "Pete's Plug" as follows:

1. Clean and lubricate gauge adapter probe with a small amount of petroleum jelly or silicone grease.
2. Assemble gauge adapter.
3. Using the appropriate sealant, screw barbed fitting into gauge adapter.
4. Install fuel hose of the proper pressure gauge onto barbed fitting.
5. Slowly unscrew protective cap from the test port plug.

NOTE: Quickly tighten the cap if escaping gas or liquid is heard or felt. Replace the plug if defective.

6. Insert gauge adapter into test port plug and secure.
7. Once the fuel pressure reading is obtained, remove gauge adapter probe and screw protective cap onto fuel pressure test port plug.

NOTE: Take necessary readings as quickly as possible. Severe deformation of the valves may occur if gauge adapter probe is left in the test port plug for a period of hours or days.

NOTE: Below 45° F. the neoprene core of the plug does not recover it's original shape as rapidly as it would at higher temperatures. Therefore, upon removal of the gauge adapter probe, the valves may not close fully and immediately, or they may remain slightly open until the operating temperature is above 45° F. Lower pressures and the length of time the gauge adapter probe is inserted also can affect the valve closing rate. The protective cap is provided to eliminate the small amount of leakage that might occur following removal of the gauge adapter probe.

8. Tighten protective cap to prevent tampering.

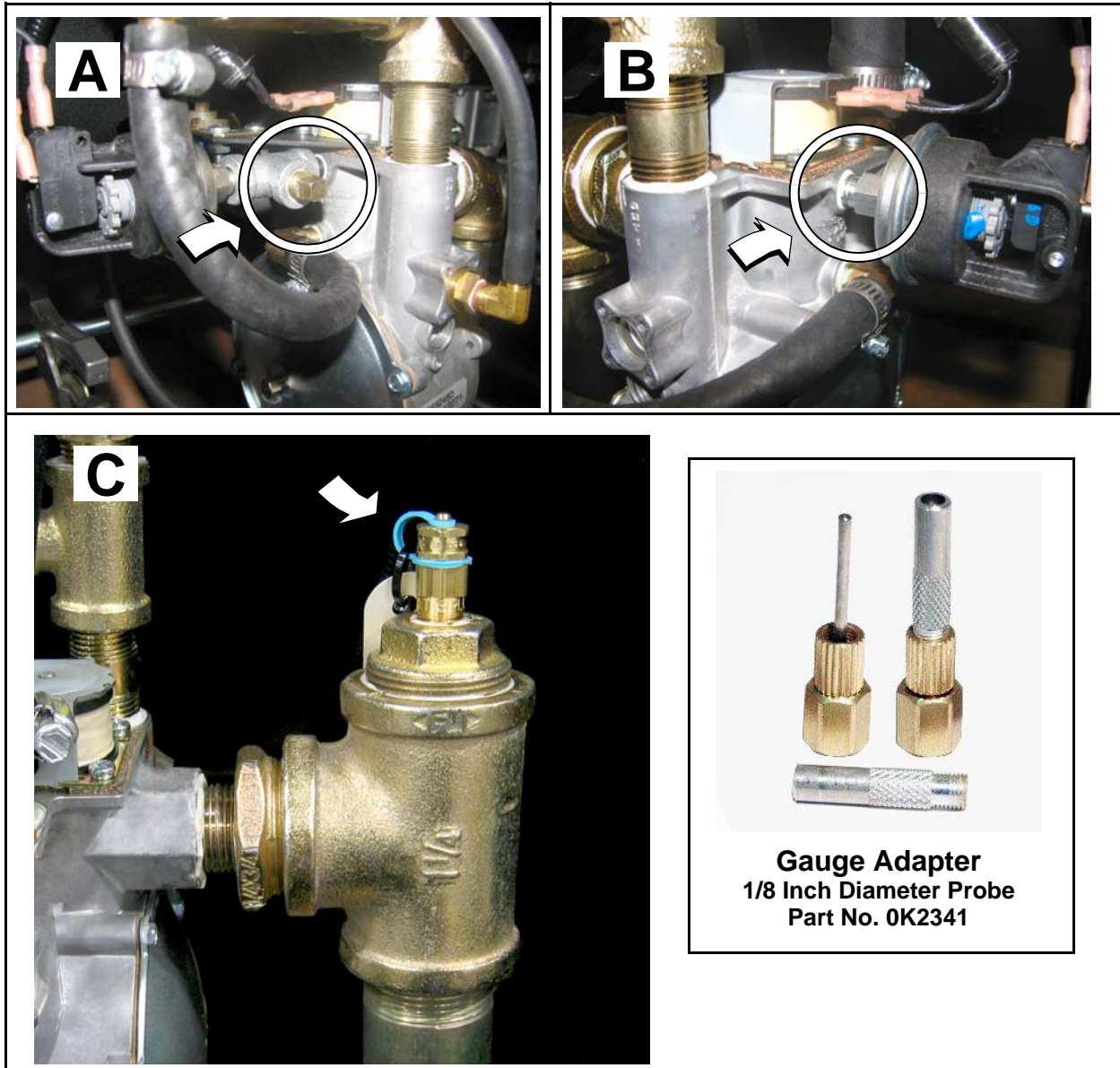

Figure 5-4. Fuel Pressure Test Points

5.6.2— Final Test Procedure

The following test must be performed at startup to document and validate fuel system operation. It requires a load bank connected to the unit, or a combination of load bank and system load, to bring the unit to its full rated kW load capacity.

Measure the fuel supply pressure under each of the following conditions:

1. **Static Pressure.** Pressure when the unit is not running. Must not exceed the maximum pressure listed in the unit specification sheet.

2. **Cranking Pressure.** Pressure when the unit is cranking. Must not drop more than 1 in. w.c. below *Static Pressure* or below the minimum pressure listed in the unit specification sheet. If it does, it may indicate that fuel supply piping is not correctly sized, or that primary regulator is improperly sized or mounted too close to the generator connection point. The unit may experience hard starting, or will not perform as expected at full load or during load transients.
3. **Running- No Load Pressure.** Pressure when the unit is running at rated frequency and voltage with no load. Should be at or slightly below the maximum pressure as listed in the unit specification sheet.
4. **Running- Full Load Pressure.** Pressure when the unit is running with full rated load applied (**kW**). Pressure should not drop more than 1-2 in. w.c. from the *Running- No Load Pressure* and must **NEVER** drop below the minimum pressure listed in the unit specification sheet.

Section 6 *Electrical System*

6.1 — General Information

All wiring must be properly sized, routed, supported, and connected. All wiring must comply with NEC and local codes. The generator uses Customer Connection Interface (CCI) panels to separate the high voltage and customer control wiring connections. These two panels are clearly labeled. The wiring diagrams for each specific unit show the connection points in their corresponding sections. Terminal boards are clearly labeled and correspond to the same terminal connections shown in the wiring diagrams. Always use the unit specific wiring diagrams when making wiring connections.

6.2 — Remove Rear Panel and Stub Up Cover

1. See Figure 6-1. Remove six screws with nylon washers to release rear panel from enclosure. For best results, rotate left side of panel outward away from enclosure before disengaging the right side.
2. Remove four screws with nylon washers to release fascia from control panel.
3. The stub up cover and five screws with flat washers are shipped loose and found inside the enclosure.

6.3 — Wiring Installation Safety

Review the safety rules at the beginning of this manual for specific dangers, cautions, and hazards associated with the installation of industrial products.

When installing the generator set and connecting wiring, keep the generator and system de-energized and disabled. It is common electrical safety practice to verify that wires are de-energized using appropriate safety gear and a meter before handling. Disable the generator by placing the AUTO/OFF/MANUAL switch in the OFF position, de-energize the battery charger, and disconnect the negative cable from the negative battery terminal. Also, make sure the auxiliary power circuit to the unit is de-energized.

6.4 — General Wiring Requirements

Consider the following general wiring requirements:

- Load Wiring - Properly size and select wiring.
- Control Wiring - Typically low DC voltage wiring (12 Vdc) that includes the 2-wire start and signal wiring. Use multi-strand wire appropriately sized for the length of run. Do not exceed #12 AWG when connecting to the customer connection terminals.
- Accessory Power Wiring - Provides power for optional user accessories (battery warmer and block heater). Size and select wiring using the appropriate tables in the NEC and per the connection requirements in the individual control panel wiring diagram.

6.5 — High Voltage Connections

The customer connection area on the left side of the control panel contains the terminals to connect all high voltage wiring. These connections are as follows:

- MLCB - E1, E2, E3 (if three-phase), and Neutral for customer load wiring. These wires run from the main line circuit breaker to the transfer switch. They supply generator power to the transfer switch and are marked for easy identification.

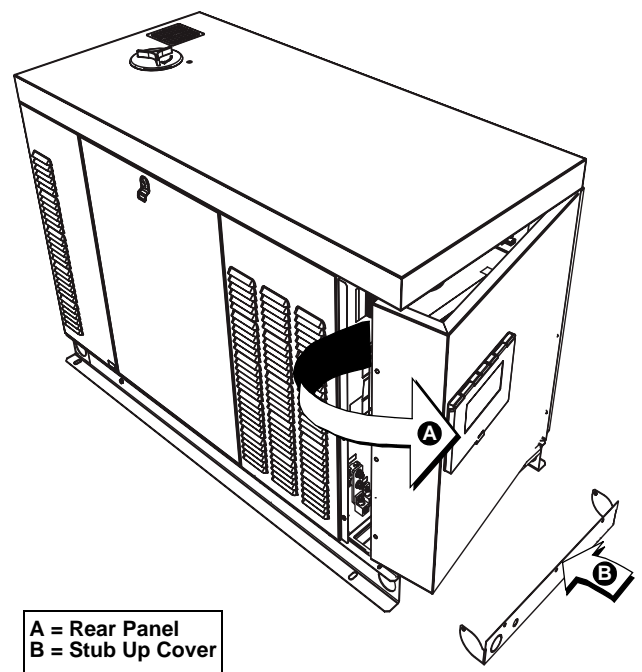

Figure 6-1. Remove Rear Panel and Stub Up Cover

NOTE: The following tables are provided for references purposes only. Refer to the latest NEC, state and local AHJ requirements for proper sizing of power and control wires.

Table 6-1. Frame Breakers

Frame Breaker	Range	Wire Type	Wire Temperature Rating	Lug AWG Range (Number of Conductors)	Torque to Wire
Generac 225 AF 2 Pole	125A-200A	Cu/Al	167° F (75° C)	6-350 kcmil (1)	375 in-lb
Generac 225 AF 3 Pole	50A-200A	Cu/Al	167° F (75° C)	6-350 kcmil (1)	375 in-lb
Generac 400 AF 2 Pole	225A-400A	Cu/Al	167° F (75° C)	1/0-250 kcmil (2) or 4-600 kcmil (1)	375 in-lb
Generac 400 AF 3 Pole	225A-400A	Cu/Al	167° F (75° C)	1/0-250 kcmil (2) or 4-600 kcmil (1)	375 in-lb

Table 6-2. Terminal Tightening Torques

Amperage Rating	Description	Cable Screw Torque	Wire Size Range
15-20 A	Load Side, Aluminum Body Lug	32 in-lb	#14 - #8 AWG Cu #12 - #8 AWG Al
25-35 A	Load Side, Aluminum Body Lug	36 in-lb	#8 - #6 AWG Cu #8 - #6 AWG Al
40-50 A	Load Side, Aluminum Body Lug	45 in-lb	#8 - #6 AWG Cu #8 - #4 AWG Al
55-70 A	Load Side, Aluminum Body Lug	50 in-lb	#8 - #4 AWG Cu #8 - #2 AWG Al
80-100 A	Load Side, Aluminum Body Lug	60 in-lb	#4 - #1/0 AWG Cu #2 - #1/0 AWG Al
10-130 A	Line Side, Threaded Contact With Ring Lugs	72 in-lb	#14 - #2 AWG

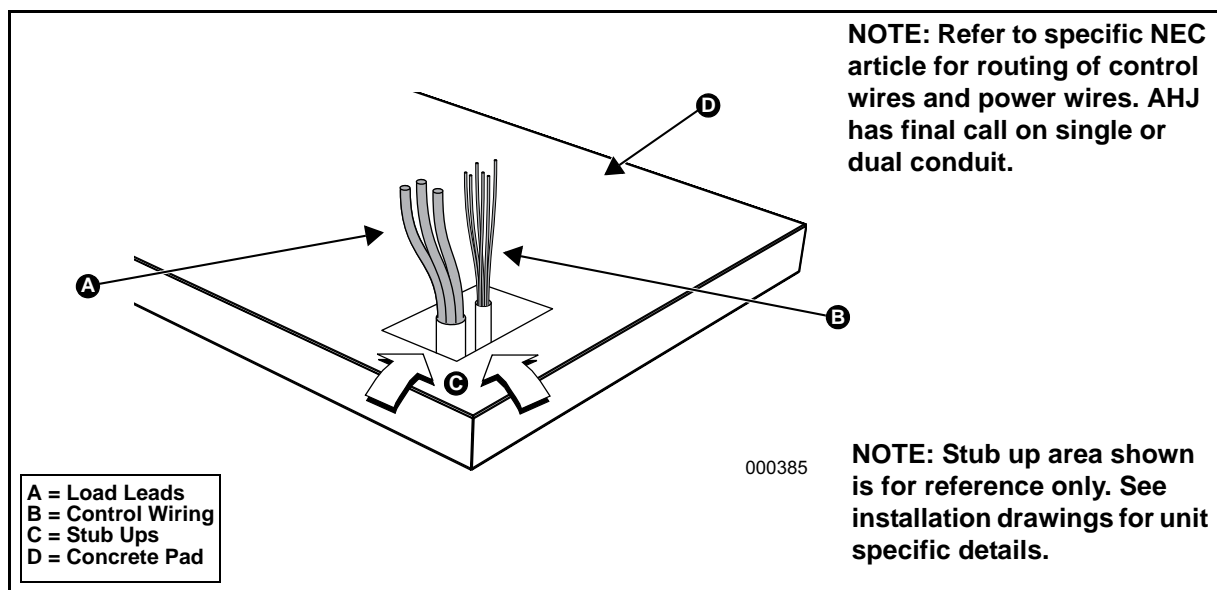

Figure 6-2. Typical Load Leads and Control Wiring in Stub Up

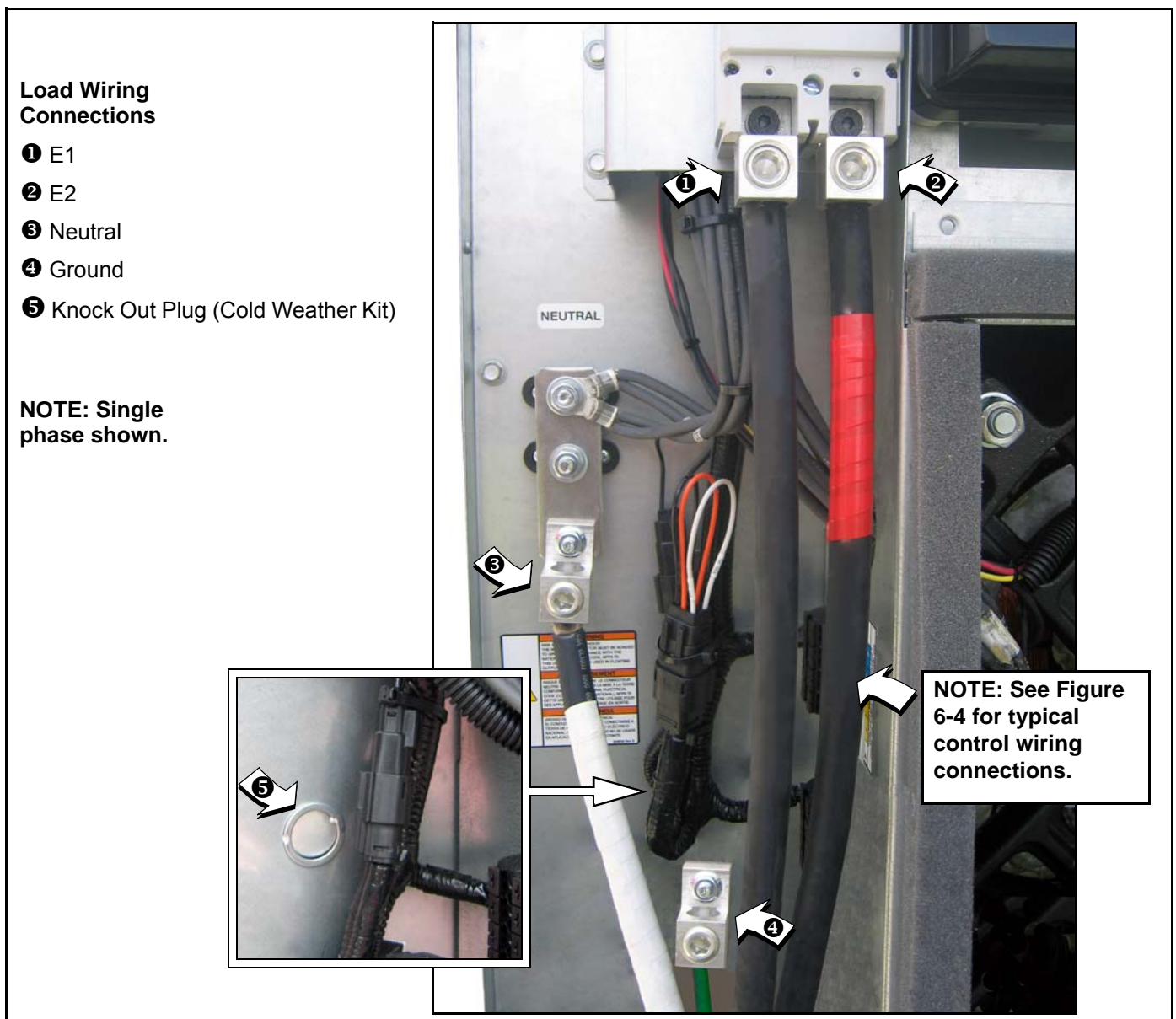

Figure 6-3. Typical High Voltage Connections

Customer load wiring consists of single-phase or three-phase connections between the generator Main Line Circuit Breaker (MLCB) and the transfer switch. The wiring connects to lugs E1, E2, E3 (if three phase on MLCB), neutral, and equipment ground at the generator and runs to the corresponding lugs in the transfer switch. All load wires, neutral and ground should be marked and terminated in the correct lugs in the transfer switch. Ensure all wiring is properly mounted and terminated at the appropriate connection points in both the generator and transfer switch. For general information regarding wire type, temperature rating, size range, and wire lug torque specifications, see Tables 6-1 and 6-2. Always refer to NEC tables for specific requirements.

NOTE: For three phase applications, use phase rotation meter to verify that the generator phase rotation matches the rotation of the utility.

NOTE: For three phase, delta configured alternators (voltage code J) the second leg (N2) must be bonded to all second legs in the entire system.

6.6 — Control Wiring Connections

The Control Wire Customer Connection block is where all of the control wiring is connected. Depending on the type of system, this wiring includes the following:

6.6.1— RTS Series Transfer Switch With T1 Fuse/Connection

NOTE: The control wire customer connections typically use Class 1 Wiring Methods (verify with AHJ). Always follow the standards and methods appropriate to the circuits being wired.

NOTE: T1 is the 120 VAC power supply for the control panel battery charger. This circuit must be powered whether the transfer switch is in utility or generator mode. If the circuit loses power the control board will generate a warning (Battery Charge AC Fail).

NOTE: Observe the maximum wire size for the terminal strip connections shown in the unit wiring diagram.

- ❶ For battery charging, connect neutral in TB2 to neutral in the transfer switch. See **NOTE** below for transfer switches without T1.
- ❷ Connect T1 in TB2 to T1 in the transfer switch. This is 120 volt supply to the unit's battery charger (normal RTS transfer switch).
- ❸ ❹ Connect N1, N2 sensing wires in TB2 to N1 and N2 in the transfer switch. These two wires are utility sensing wires.
- ❺ ❻ Connect 23 in TB3 to 23 in the transfer switch. Connect 194 in TB3 to 194 in the transfer switch. These are the transfer switch control wires.

Control Wiring Connections

NOTE: All wiring must comply with NEC, state and local AHJ requirements.

IMPORTANT: Control wiring must be installed in the provided 600V rated electrical sleeving. The sleeving is shipped loose and can be found in the **manual bag** attached to one of the louvered panels of the enclosure.

NOTE: Wire colors are shown for illustration purposes only.

TB2 Terminal Block			TB3 Terminal Block			
Terminal	Function	Voltages	Terminal	Function	Voltages	
❶	Neutral	Neutral for T1 Battery Charger		178	Two Wire Start Control [GTS]	5-12 VDC
❷	T1	Power for T1 Battery Charger		183	Two Wire Start Control [GTS]	5-12 VDC
❸	N2	Utility Sensing from Transfer Switch	❺	23	Transfer Relay Control Wire	12-0 VDC
❹	N1	Utility Sensing from Transfer Switch	❻	194	Power for Transfer Relay	12 VDC

Figure 6-4. Typical Control Wiring Connections

6.6.2— RTS Series Transfer Switch Without T1 Fuse/Connection

Use a 120 volt generator protected circuit from the panel board to power the battery charger circuit (dedicated 15/20 amp circuit).

6.6.3— Two-Wire Start

To convert transfer switches to 2 wire start mode of operation, see dealer for panel conversion and connection of terminals 178 and 183 in TB3. Use a 120 volt generator protected circuit from the panel board to power the battery charger circuit (dedicated 15/20 amp circuit).

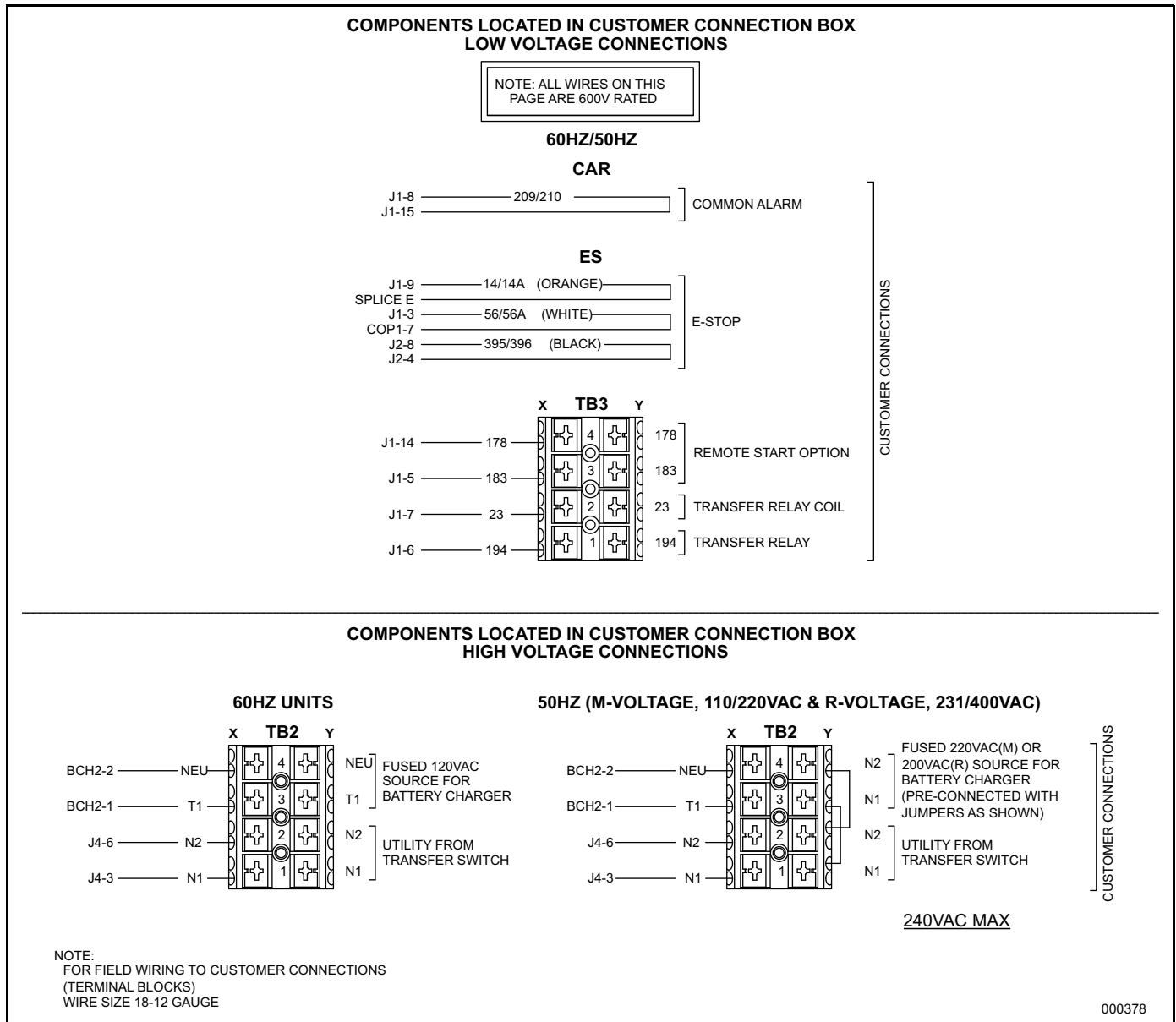

Figure 6-5. Typical Control Wiring Schematic

NOTE: The following table is provided for references purposes only. Refer to the latest NEC, state and local AHJ requirements for proper sizing.

Table 6-3. Control Wire Length/Size

Maximum Wire Length	Recommended Wire Size
1-115 ft (1-35m)	No. 18 AWG
116-185 ft (36-56m)	No. 16 AWG
186-295 ft (57-89m)	No. 14 AWG
296-460 ft (90-140m)	No. 12 AWG

6.7 — Optional Accessory Power

- Accessory power for optional items (battery warmer and block heater) should come from a customer utility supply source (with appropriate sized breaker), which is also powered by emergency power during an outage.
- Optional user installed GFCI receptacles. Provides a place to plug in optional battery warmer and block heater.

NOTE: Remove knock out plug and route accessory wiring to customer supplied weather-proof junction box. See Figure 6-3. Verify that wires do not contact moving or vibrating engine parts, as abraded wires can result in electrical problems.

6.8 — Install Stub Up Cover and Rear Panel

1. Install five screws with flat washers to secure stub up cover.
2. Install four screws with nylon washers to fasten fascia over control panel.
3. Install rear panel. For best results, first engage right side of panel and then rotate left side inward toward enclosure. Alternately work left and right sides in until slots are aligned with screw holes on both sides. Install six screws with nylon washers and tighten until snug.

6.9 — Transfer Switch Location

The location of the transfer switch is important. Consider the following:

1. Locate the transfer switch as close to the emergency load as practical to avoid interruptions of the emergency power system due to natural disasters or equipment failures.
2. Locate the transfer switch in a clean, dry, well ventilated location, away from excessive heat. Allow adequate working space around the transfer switch. Refer to the latest NEC, state and local AHJ requirements for details.
3. Install power and control wires as per NEC requirements. In a three phase system, all power conduits from the generator set must contain all three phases.
4. Conduit, wire, circuit protective device sizes, insulation etc. must conform to applicable local and national codes and regulations.

6.10 — Battery

6.10.1— General Cautions

⚠ DANGER!



Stationary emergency generators installed with automatic transfer switches will crank and start automatically when NORMAL (UTILITY) source voltage is removed or is below an acceptable preset level. To prevent automatic startup and possible injury to personnel, do not connect battery cables until NORMAL source voltage at the transfer switch is correct and the system is ready to be placed into operation.



Storage batteries give off **EXPLOSIVE** hydrogen gas. This gas can form an explosive mixture around the battery for several hours after charging. The slightest spark can ignite the gas and cause an explosion. An explosion can shatter the battery and cause blindness or other injury. Any area that houses a storage battery must be properly ventilated. Do not allow smoking, open flame, sparks, or any spark producing tools or equipment near the battery.



When working on the battery, always remove watches, rings, or other metal objects, and only use tools that have insulated handles. Do not lay tools or metal parts on top of the battery.



Discharge static electricity from the body before touching the battery by first touching a grounded metal surface.



Wear full eye protection, protective clothing, and gloves when handling a battery.



Battery electrolyte fluid is an extremely caustic sulfuric acid solution that can cause severe burns. Do not permit fluid to contact eyes, skin, clothing, painted surfaces, etc. Where electrolyte contacts the skin, wash it off immediately with water. If contact is with eyes, flush thoroughly and immediately with water and seek medical attention.

NOTE: Immediately wash down spilled electrolyte with an acid neutralizing agent. Use a solution of 1 pound (500 grams) bicarbonate of soda to 1 gallon (4 liters) of water. Add the bicarbonate of soda solution until evidence of reaction (foaming) has ceased. Flush the resulting liquid with water.

6.10.2— Battery Size

The ability to start the engine depends upon battery capacity, ambient temperatures and coolant and oil temperatures. The engine/generator set Data Sheet lists minimum recommended battery capacity at various ambient temperatures. The recommended battery capacities are listed under cold cranking amps (CCA) at 0 °F (-18 °C). Battery capacities decrease as ambient temperatures decrease, so it is important to specify batteries with the appropriate CCA rating at a temperature no higher than the minimum ambient temperature for the application.

6.10.3— Battery Installation

⚠ CAUTION!



Always connect the positive battery cable first. If the positive cable should contact ground with the negative cable installed, the resulting sparks may cause a battery explosion which could result in serious injury.

NOTE: Use appropriate tools when working with battery terminals. The use of terminal pullers, expansion pliers and terminal cleaning brushes will greatly extend the life of the battery terminals.

1. Install rubber protective cover over battery positive (+) terminal. See A of Figure 6-6.
2. Grasp battery strap and lift battery. See B of Figure 6-6.
3. Set battery onto battery tray.
4. Tighten two screws with nylon washers to secure hold-down clamp to battery tray.
5. Remove rubber protective cover from battery positive (+) terminal.
6. Install battery positive cable (red) to battery positive (+) terminal.
7. Install battery negative cable (black) to battery negative (-) terminal.

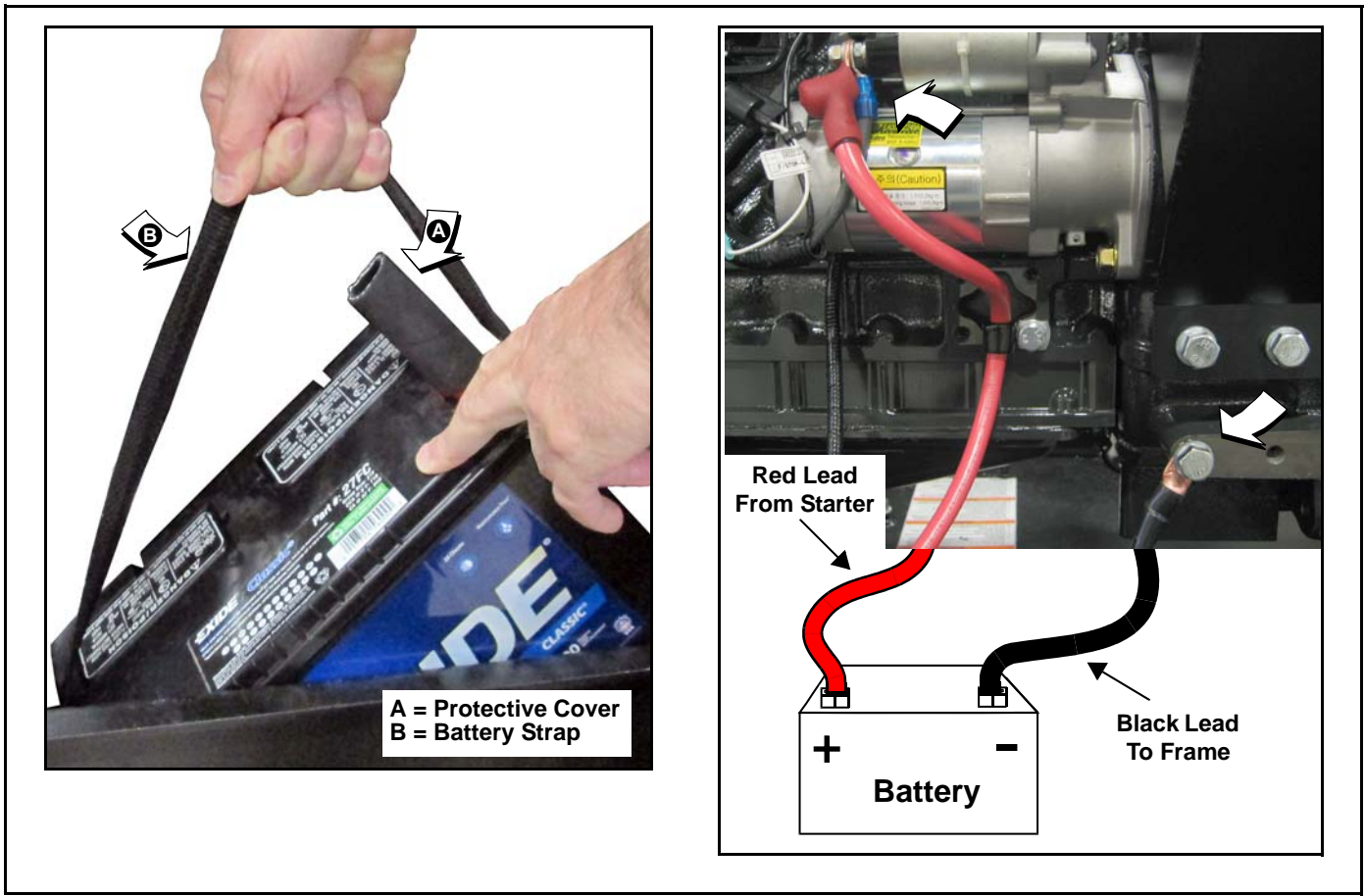
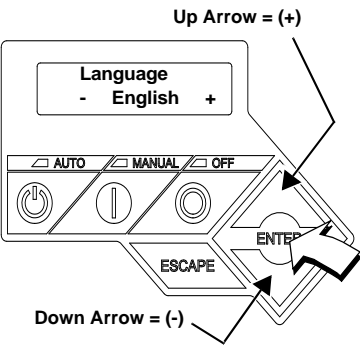

Figure 6-6.

6.11 — Activate Unit

<p>Display Reads:</p>  <p>Up Arrow = (+)</p> <p>Down Arrow = (-)</p>	<p>Generator Active is displayed on the LCD screen when the unit is first powered up. After displaying firmware and hardware version codes, as well as other system information, the Installation Wizard is launched, and the Language screen is displayed.</p> <p>Use UP ARROW or DOWN ARROW to scroll to desired language.</p> <p>Press ENTER.</p>	<p>If the wrong language is selected, it may be changed later using the Edit menu.</p>
<p>Display Reads:</p> <div style="border: 1px solid black; padding: 5px; text-align: center;"> <p>Activate me (ENT) or ESC to run in manual</p> </div>	<p>Press ENTER.</p>	<p>Press ESCAPE to abort the activation sequence. NOT ACTIVATED is displayed and the generator will run in manual mode only. Disconnect and reconnect the negative battery cable to restart the activation routine. If power is removed after a successful activation, no data is lost, but the time and date must be updated.</p>
<p>Display Reads:</p> <div style="border: 1px solid black; padding: 5px; text-align: center;"> <p>To Activate go to www.activategen.com</p> </div>	<p>Go to www.activategen.com or call 1-888-9ACTIVATE (922-8482, US & Canada only) if activation passcode is not available.</p> <p>If activation pass code is available, wait a few seconds for the next display.</p>	
<p>Display Reads:</p> <div style="border: 1px solid black; padding: 5px; text-align: center;"> <p>SN 1234567890 PASS CODE XXXXX</p> </div>	<p>Use UP ARROW or DOWN ARROW to increment or decrement the digit to correspond to the first number of the pass code.</p> <p>Press ENTER.</p> <p>Repeat step to enter remaining digits.</p>	<p>Press ESCAPE to return to preceding digits if a correction becomes necessary.</p> <p>If attempts to enter the activation code are unsuccessful, check the number against the code given on activategen.com. If it is correct, contact 1-888-9ACTIVATE (922-8482, US & Canada only).</p>
<p>Display Reads:</p> <div style="border: 1px solid black; padding: 5px; text-align: center;"> <p>Select Hour (0-23) - 6 +</p> </div>	<p>Use UP ARROW or DOWN ARROW to increment or decrement the hour. Press ENTER.</p> <p>Use UP ARROW or DOWN ARROW to increment or decrement the minute. Press ENTER.</p> <p>Use UP ARROW or DOWN ARROW to select the month. Press ENTER.</p> <p>Use UP ARROW or DOWN ARROW to increment or decrement the date. Press ENTER.</p> <p>Use UP ARROW or DOWN ARROW to increment or decrement the year. Press ENTER.</p>	

<p>Display Reads:</p> <div style="border: 1px solid black; padding: 10px; text-align: center;"> <p>Quiet Test Mode? Yes No</p> </div>	<p>Use UP ARROW or DOWN ARROW to select either Yes or No.</p> <p>Press ENTER.</p>	<p>Select YES to perform exercise at low speed. Select NO to perform exercise at normal operating speed.</p>
<p>Display Reads:</p> <div style="border: 1px solid black; padding: 10px; text-align: center;"> <p>Select Hour (0-23) - 1 +</p> </div>	<p>Set Exercise Time.</p> <p>Use UP ARROW or DOWN ARROW to increment or decrement the hour. Press ENTER.</p> <p>Use UP ARROW or DOWN ARROW to increment or decrement the minute. Press ENTER.</p> <p>Use UP ARROW or DOWN ARROW to scroll to the day of the week. Press ENTER.</p>	<p>In the AUTO mode, the engine starts and runs once each week at the time and day specified. During the exercise cycle, the unit runs approximately 12 minutes and then shuts down. Transfer of loads to the generator does not occur unless utility power fails.</p>

6.12 — Operational Checks

NOTE: The following procedures require special tools and skills. Contact a Generac Dealer or an authorized service provider to perform these tasks.

6.12.1— Self Test

Upon power up, the controller goes through a system self test which checks for the presence of utility voltage on the DC circuits. This is done to prevent damage if the installer mistakenly connects AC utility power sense wires into the DC terminal block. If utility voltage is detected, the controller displays a warning message and locks out the generator, thereby preventing damage to the controller. Remove power to the controller to clear this warning.

Utility voltage must be turned on and present at the N1 and N2 terminals inside the generator control panel for this test to be performed and pass.

Before starting, complete the following:

1. Verify that the generator is OFF. A red LED above OFF on the control panel keypad illuminates to confirm that the system is in the OFF mode.
2. Verify that the Main Circuit Breaker switch on the generator control panel is in the OFF (Open) position.
3. Turn off all circuit breakers/electrical loads that will be powered by the generator.
4. Check the engine crankcase oil level, coolant level, and fuel level, if necessary.

During initial start up only, the generator may exceed the normal number of start attempts and experience an “over crank” fault. This is due to accumulated air in the fuel system during installation. Reset the control board and restart up to two more times, if necessary. If unit fails to start, contact the local dealer for assistance.

6.12.2— Check Manual Transfer Switch Operation

Refer to the “Manual Transfer Operation” section of the owner’s manual for procedures.

NOTE: Also use the appropriate transfer switch owner’s manual for manual and automatic system test.

⚠ DANGER!



Do not attempt manual transfer switch operation until all power voltage supplies to the transfer switch have been positively turned off. Failure to turn off all power voltage supplies will result in extremely hazardous and possibly fatal electrical shock.

6.12.3— Electrical Checks

NOTE: Verify that all power and control wiring is properly terminated in the generator and corresponding location in transfer switch. For three phase applications, verify that generator phase rotation matches utility phase rotation.

Complete electrical checks as follows:

1. Verify that the generator is OFF. A red LED above OFF on the control panel keypad illuminates to confirm that the system is in the OFF mode.
2. Verify that the Main Circuit Breaker switch on the generator control panel is in the OFF (Open) position.
3. Turn OFF all circuit breakers/electrical loads that will be powered by the generator.
4. Turn on the utility power supply to the transfer switch using the means provided (such as a utility main line circuit breaker).

⚠ DANGER!



The transfer switch is now electrically “hot.” Contact with “hot” parts will result in extremely hazardous and possibly fatal electrical shock.

5. Use an accurate AC voltmeter to check utility power source voltage across transfer switch terminals N1, N2, and N3 (if three phase). Normal line-to-line voltage should be equivalent to rated unit voltage.
6. Check utility power source voltage across terminals N1, N2, and N3 (if three phase) and the transfer switch neutral lug.
7. When certain that utility supply voltage is compatible with transfer switch and load circuit ratings, turn OFF the utility power supply to the transfer switch.
8. Press MANUAL on the control panel keypad to crank and start the engine.
9. Allow the engine to warm up for about five minutes. Move the Main Circuit Breaker switch on the generator control panel up to the ON (Closed) position.

⚠ DANGER!



Generator power voltage is now supplied to the transfer switch. Contact with live transfer switch parts will result in dangerous and possibly fatal electrical shock.

10. Connect an accurate AC voltmeter and a frequency meter across transfer switch terminal lugs E1, E2, and E3 (if three phase).
11. Successively connect the AC voltmeter test leads across terminal lugs E1, E2, and E3 (if three phase) and neutral. Voltage reading in each case should match utility voltage reading. If system is three phase, verify that generator phase rotation matches utility phase rotation.
12. Move the Main Circuit Breaker switch on the generator control panel down to the OFF (Open) position.
13. Press OFF on the control panel keypad to shut the engine down.

⚠ DANGER!



Do not proceed unless certain that generator AC voltage and frequency are correct and within the stated limits.

6.12.4— Test Generator Under Load

To test the generator set with electrical loads applied, proceed as follows:

1. Verify that the generator is OFF. A red LED above OFF on the control panel keypad illuminates to confirm that the system is in the OFF mode.
2. Turn OFF all breakers/electrical loads that will be powered by the generator.
3. Turn OFF the utility power supply to the transfer switch, using the means provided (such as a utility main line circuit breaker).

⚠ DANGER!



Do not attempt manual transfer switch operation until all power voltage supplies to the transfer switch have been positively turned off. Failure to turn off all power voltage supplies will result in extremely hazardous and possibly fatal electrical shock.

4. Manually set the transfer switch to the STANDBY position, i.e., load terminals connected to the generator's E1, E2, and E3 (if three phase) terminals. The transfer switch operating lever should be down.

5. Press MANUAL on the control panel keypad. The engine should crank and start immediately.
6. Allow the engine to warm up for a few minutes.
7. Move the Main Circuit Breaker switch on the generator control panel up to the ON (Closed) position. Loads are now powered by the standby generator.
8. Turn ON the circuit breaker/electrical loads powered by the generator.
9. Connect a calibrated AC voltmeter and a frequency meter across terminal lugs E1, E2, and E3 (if three phase). Voltage should be approximately unit rated voltage.
10. Let the generator run at full rated load for 20-30 minutes. Listen for unusual noises, vibration or other indications of abnormal operation. Check for oil leaks, evidence of overheating, etc.
11. When testing under load is complete, turn OFF electrical loads.
12. Move the Main Circuit Breaker switch on the generator control panel down to the OFF (Open) position.
13. Allow the engine to run at no-load for 2-5 minutes.
14. Press OFF on the control panel keypad to shut the engine down.

6.12.5— Check Automatic Operation

To check the system for proper automatic operation, proceed as follows:

1. Verify that the generator is OFF. A red LED above OFF on the control panel keypad illuminates to confirm that the system is in the OFF mode.
2. Install front cover over the transfer switch.
3. Turn ON the utility power supply to the transfer switch, using the means provided (such as a utility main line circuit breaker).

NOTE: Transfer Switch will transfer back to utility position.

4. Move the Main Circuit Breaker switch on the generator control panel up to the ON (Closed) position.
5. Press AUTO on the control panel keypad. The system is now ready for automatic operation.
6. Turn OFF the utility power supply to the transfer switch.

With the generator ready for automatic operation, the engine will crank and start when the utility source power is turned OFF after a 10 second delay (factory default setting). After starting, the transfer switch connects load circuits to the standby side. Let the system operate through its entire automatic sequence of operation.

With the generator running and loads powered by generator AC output, turn ON the utility power supply to the transfer switch. The system transfers back to the utility position and then runs through the cool down cycle and shuts down.

6.13 — Installation Summary

1. Ensure that the installation has been properly performed as outlined by the manufacturer and that it meets all applicable laws and codes.
2. Test and confirm proper operation of the system as outlined in the appropriate installation and owner's manuals.
3. Educate the customer on the proper operation, maintenance and service call procedures.

IMPORTANT! If the customer ever finds it necessary to turn the generator off during prolonged utility outages to conserve fuel or perform maintenance, alert them to these important steps:

To turn the generator OFF (while running in AUTO and online):

1. Turn OFF (or open) the main Utility disconnect.
2. Move the Main Circuit Breaker switch on the generator control panel down to the OFF (Open) position.
3. Press OFF on the control panel keypad. A red LED illuminates to confirm that the system is in the OFF mode.

To turn the generator back ON:

1. Press AUTO on the control panel keypad. Allow the unit to start and warm up for a few minutes.
2. Move the Main Circuit Breaker switch on the generator control panel up to the ON (Closed) position.

The system is now operating in the automatic mode. The main utility disconnect can be turned ON (Closed), but to shut the unit off, this complete process must be repeated.

Section 7 Lube Oil Maintainer System

7.1 — Lube Oil Maintainer System

7.1.1— Description

NOTE: Oil reservoir is empty when shipped from factory. Fill with clean engine oil to activate the system.

Oil reservoir capacity: 2.5 gallons (9.46 liters)

The 36 kW, 45 kW, and 60 kW models are equipped with a Lube Oil Maintainer System. The system is installed at the factory and calibrated at the factory to the correct engine-running crankcase oil level. As needed, the system keeps the engine lubricating oil full by automatically adding clean oil from the oil supply tank.

See A of Figure 7-1 The green bar observed through the viewing lens shows the normal oil level operating range of the Lube Oil Maintainer Regulator during engine running operation. When the oil level is within the green bar, the internal float holds the inlet valve closed to keep the crankcase oil at the current level.

As the engine uses oil, the float drops to open the inlet valve and allow clean oil to be supplied to the crankcase, replenishing engine oil to the full mark indicated on the oil dipstick. The float then rises with the crankcase oil level until it reaches a point where the inlet valve closes.

When the oil level as observed through the viewing lens is below the normal operating range green bar, it is an indication that the oil supply tank is low or the oil inlet screen is clogged. See B of Figure 7-1

NOTE: It is normal for the oil level to be above the normal operating range green bar when engine is not running.

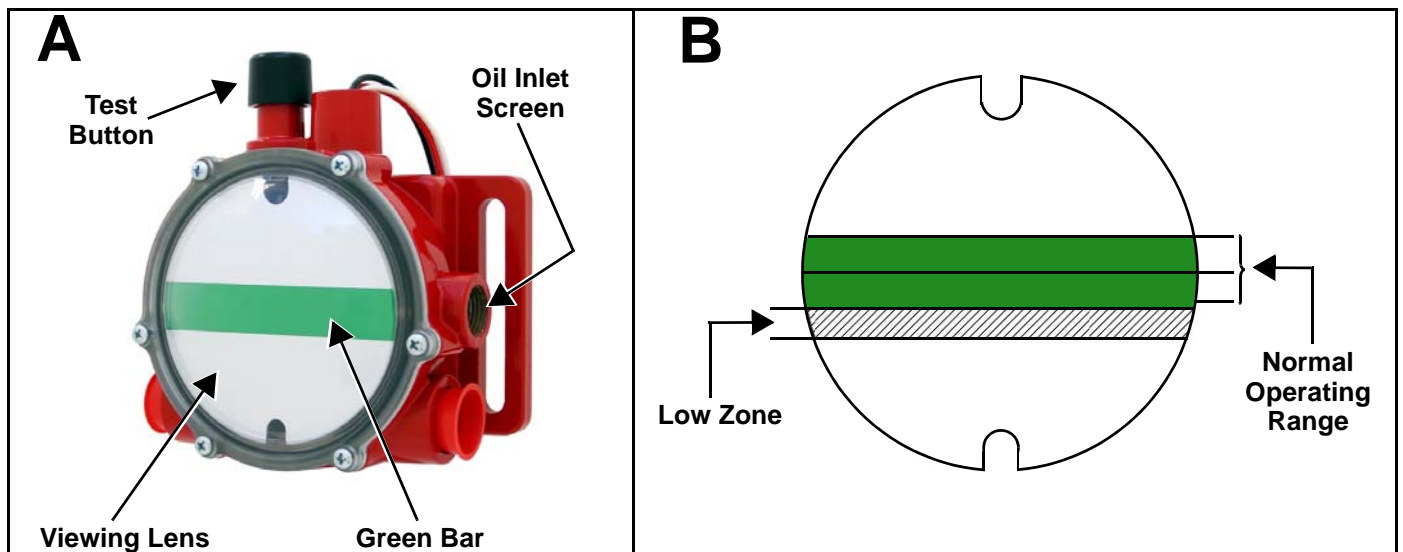

Figure 7-1. Lube Oil Maintainer Regulator

NOTE: When changing engine oil, always close the shutoff valve to avoid draining the clean oil in the oil supply tank with the crankcase oil. See Figure 7-3

7.1.2— Fill Oil Supply Tank

1. Rotate plastic cover counter-clockwise and remove from top of enclosure. See Figure 7-2
2. Remove fill cap at top of oil supply tank (Figure 7-2).
3. Add clean engine oil to oil supply tank (2-1/2 gallons [9.46 liters] capacity).
4. Install fill cap at top of oil supply tank.
5. Install plastic cover at top of enclosure and rotate clockwise until tight.

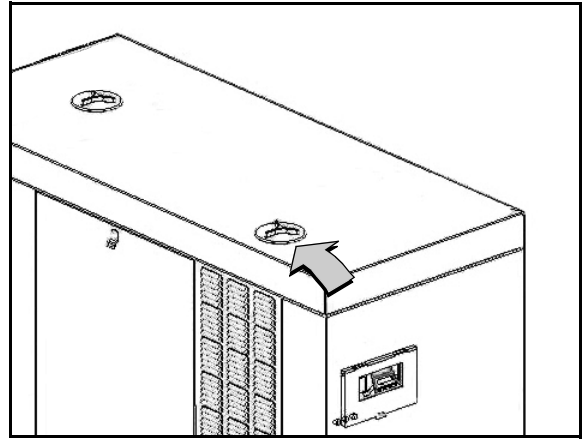

Figure 7-2. Access Oil Supply Tank

7.1.3— Test Functionality

See A of Figure 7-1 Momentarily press the test button to confirm that the float is operating correctly.

▲ CAUTION!



Do not hold the test button down for a prolonged period of time or the crankcase can be over filled. Over filling the crankcase can result in engine damage.

7.1.4— Shutoff Valve

See Figure 7-3 and Figure 7-4 When draining engine crankcase oil, always close shutoff valve to avoid draining clean oil from supply tank.

After filling crankcase with clean oil, remember to open shutoff valve to enable operation of Lube Oil Maintainer System.

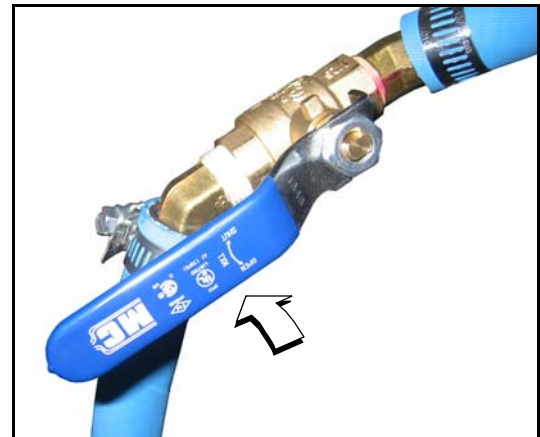

Figure 7-3. Shutoff Valve (Shown in Open Position)

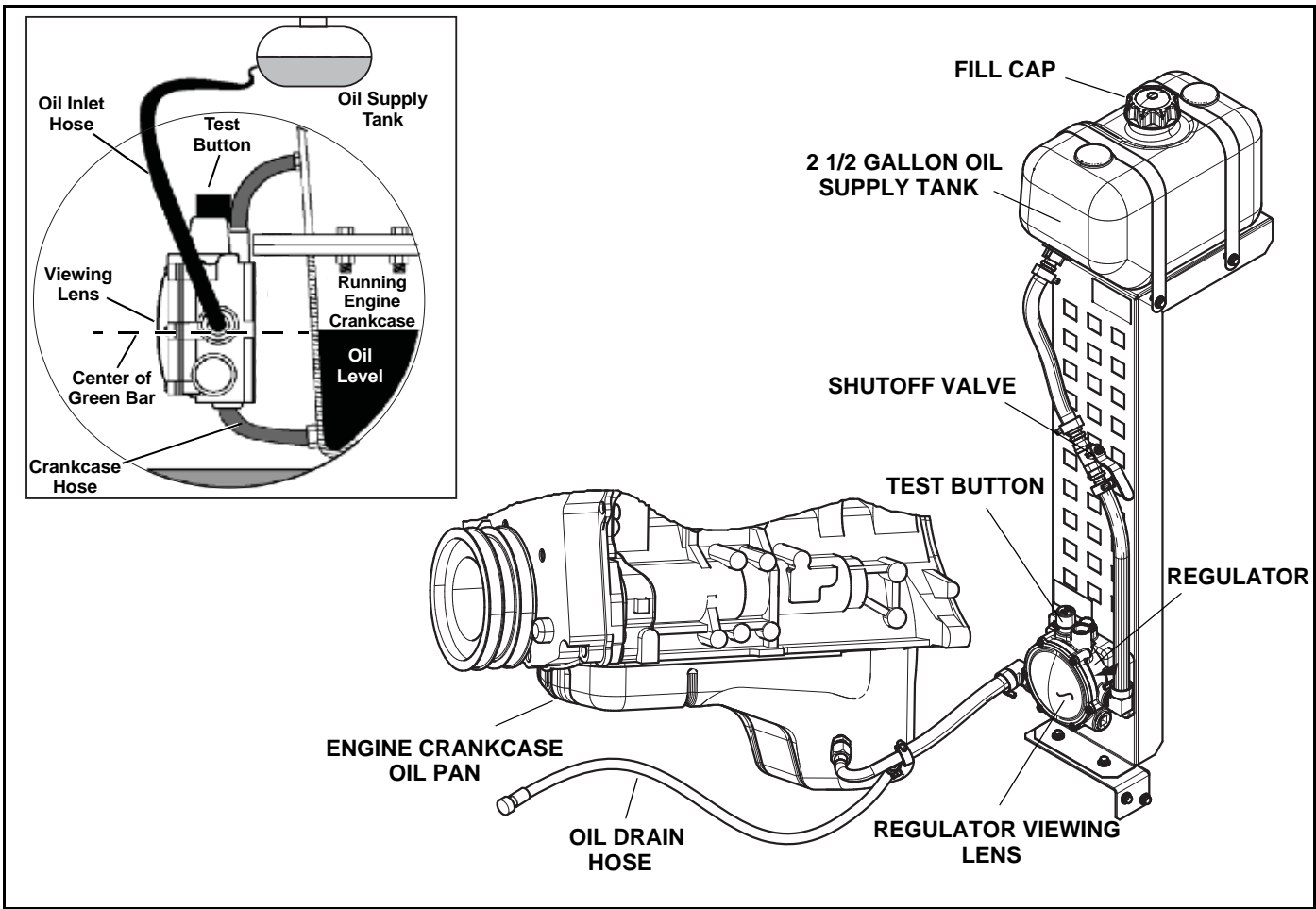

Figure 7-4. Lube Oil Maintainer Assembly and Function Diagram

This page intentionally left blank.

Section 8 *Installation Checklists*

8.1 — Safety Checklist

NOTE: See Chapter 1 for more information.

- Are manuals, wiring diagrams and other documentation readily available?
- Is there any evidence of freight damage?
- Does the enclosure have scratches or damage to painted surfaces (which would indicate lifting without a spreader bar)?
- Are all guards, covers, insulation blankets and other protective devices in place?
- Are any parts or components worn, damaged or missing?
- Is the generator properly grounded?
- Is a fire extinguisher kept near the generator?
- Is there any evidence of oil or coolant leaks?
- Are any combustible materials left in the generator compartment?
- Is the area surrounding the generator clean and free of debris?
- Do these parameters meet all applicable codes and local jurisdiction?

8.2 — Installation Planning Checklist

NOTE: See Chapter 2 for more information.

- Is the generator set readily accessible for maintenance, repair, and firefighting purposes?
- Is the site clean and dry? Is the site provided with adequate drainage?
- Is there a minimum of five feet of clearance around the generator set to facilitate the repair or replacement of major components?
- Have adequate provisions been made for installation of the fuel supply?
- Do these parameters meet all applicable codes and local jurisdiction?

8.3 — Foundations and Mounting Checklist

NOTE: See Chapter 3 for more information.

- Is the generator set installed on a concrete pad capable of supporting its weight and accessories?
- Is the generator securely fastened to the concrete pad using suitable grade, size and style fasteners?
- Is the concrete pad seated on a prepared solid subsurface using appropriate reinforcing bar or expanded wire mesh?

- Does the concrete pad extend beyond the frame rails at least six (6) inches (15.24 cm) on all sides?
- Is the concrete pad flat and level to within 1/2 inch?
- Are plugs installed in the tie-down holes of the frame rail?
- If installed on a roof or combustible floor, is the generator seated on a layer of sheet metal and non-combustible insulation? Do the sheet metal and insulation extend beyond the generator base at least six (6) inches (15.24 cm) on all sides?
- Is the base frame stub-up cover plate installed?
- Do all fuel, coolant, exhaust, and electrical lines have flexible sections where they connect to the generator?
- Is all piping properly supported and secured?
- Do these parameters meet all applicable codes and local jurisdiction?

8.4 — Ventilation System Checklist

NOTE: See Chapter 4 for more information.

- Is there sufficient air flow for cooling and ventilation?
- Are all bushes, shrubs and other vegetation a minimum of 3 feet away?
- Does the air inlet face the direction of prevailing winds?
- Has system piping been properly sized? Have all gas loads been taken into consideration?
- Has system been properly protected from freeze up and corrosion?
- Have standby equipment heaters been specified?
- Have system drain valves and air eliminators been installed?
- Does the air outlet face noise sensitive areas without noise attenuating devices?
- Does the installation appear to have the necessary accessories to enable fast, reliable starting and operation in adverse weather conditions (such as engine block heaters, battery warmers, etc.)?
- Do these parameters meet all applicable codes and local jurisdiction?

8.5 — Exhaust System Checklist

NOTE: See Chapter 5 for more information.

- Are exhaust discharges directed away from combustible surfaces and inhabited areas?
- Is exhaust piping kept clear of fuel supply, fuel lines, etc.?
- Is off-engine exhaust piping covered with high temperature insulation blankets where necessary?
- Do these parameters meet all applicable codes and local jurisdiction?

8.6 — Gaseous Fuel System Checklist

NOTE: See Chapter 5 for more information.

- Are fuel supply lines properly sized and installed? Were fuel supply lines purged and leak tested?
- Are sediment traps and drip legs installed to remove water and condensate from the gas flow?
- Is the fuel pressure regulator properly sized?
- Is a pressure test port installed before the fuel shutoff solenoids at the inlet to the unit mounted regulator?
- Does the generator have a dedicated fuel line which is not shared with any other appliances?
- Is the regulator sized to have a fuel flow delivery rating (CFH) at least 10% greater than the 100% rated kW fuel consumption requirement of the generator?
- Is the fuel pressure regulator approved for a mechanized engine application?
- Does the fuel pressure regulator have an accuracy rating of 1% or less and/or have a maximum allowable pressure drop of 1-2 inches w.c. under all operating conditions, that is, static, cranking, running at no load, and running at full load (as measured at the primary fuel pressure regulator)?
- Does the fuel pressure regulator have a spring rating of 5-14 inches w.c.?
- Does the system use black iron piping or other approved gas line?
- Is the gas line rigidly mounted and protected against vibration?
- Is a length of flexible hose installed between the generator connection point and the rigid supply piping? Is the flexible hose straight without bends, twists or kinks?
- Is the piping correctly sized to maintain the required supply pressure and volume under varying load conditions?
- Was an approved pipe sealant or joint compound used on all threaded fittings?
- Is a fuel shutoff valve installed near the unit? Was proper operation of the fuel shutoff valve verified?
- Was the Final Operating Test performed to verify that the system operates correctly in all modes of operation?
- Is there any evidence of leakage at any hoses, clamps or fittings?
- Do these parameters meet all applicable codes and local jurisdiction?

8.7 — Electrical System Checklist

NOTE: See Chapter 6 for more information.

- Is all wiring correctly sized for load and length of run?
- Is all wiring correctly routed?
- Is all wiring correctly connected?
- Are wire lugs fastened to buss bars using appropriate hardware? Is hardware properly tightened to specified torque?
- Are all other terminals correctly tightened using the specified torque?
- Are batteries correctly sized?

- Are batteries correctly installed?
- Are the battery fluid levels correct?
- Are battery cables and connections clean and free of corrosion?
- Are the battery cables correctly connected? Are the terminal lugs correctly tightened?
- Is the battery condition and state of charge acceptable?
- Is area housing storage battery properly ventilated?
- Are batteries located near a source of flame or spark?
- Are AC wire sizes and connections correct?
- Are DC and communication wire sizes and connections correct?
- Are DC and communication wires routed separately from AC wires (per code)?
- Are block heaters, battery charger, etc. properly matched with utility supply voltage?
- Are battery charger and block heater properly connected?
- Are remote start Wires 178 & 183 pulled and connected inside lower control panel of generator and inside transfer switch?
- Is the AUTO/OFF/MANUAL mode in the "OFF" position?
- Is the block heater operational?
- Is the battery charger operational?
- Are all AC electrical connections tight at the circuit breaker and transfer switch?
- Are all electrical connections (wiring, wire ties, clamps, terminal ends, connectors) on the generator tight?
- Are all electrical plugs throughout the generator seated correctly and fully inserted into their receptacles?
- Is there proper voltage and phase rotation at the transfer switch?
- Is manual operation of the transfer switch smooth and non-binding?
- Do these parameters meet all applicable codes and local jurisdiction?

8.8 — Oil Maintainer System Checklist

NOTE: See Section 7 for more information.

- Has the oil maintainer oil supply tank been filled with the recommended engine oil and tested?
- Has the oil maintainer been tested to the proper level?

Section 9 Installation Drawings

9.1 — 0K8420-A 25/30 kW (1.5 L) Page 1 of 2

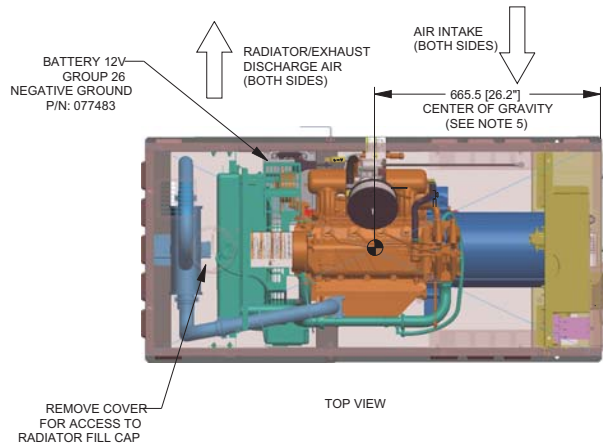

SERVICE ITEM	1.5L
OIL FILL CAP	EITHER DOOR
OIL DIP STICK	RIGHT DOOR
OIL FILTER	RIGHT DOOR
OIL DRAIN HOSE	RIGHT DOOR
RADIATOR DRAIN HOSE	RIGHT DOOR
AIR CLEANER ELEMENT	RIGHT DOOR
SPARK PLUGS	RIGHT DOOR
MUFFLER	SEE NOTE 12
FAN BELT	EITHER DOOR
BATTERY	RIGHT DOOR

REFERENCE OWNERS MANUAL FOR PERIODIC REPLACEMENT PART LISTINGS.

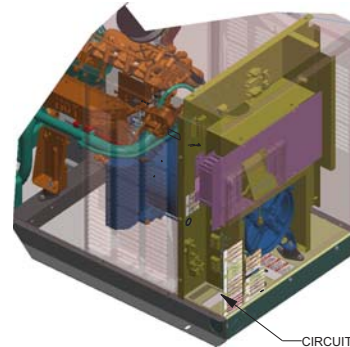

NOTES:

- MINIMUM RECOMMENDED CONCRETE PAD SIZE: 1092 (43") WIDE X 1887 (74.3") LONG. REFERENCE INSTALLATION GUIDE SUPPLIED WITH UNIT FOR CONCRETE PAD GUIDELINES.
- ALLOW SUFFICIENT ROOM ON ALL SIDES OF THE GENERATOR FOR MAINTENANCE AND SERVICING. THIS UNIT MUST BE INSTALLED IN ACCORDANCE WITH CURRENT APPLICABLE NFPA 37 AND NFPA 70 STANDARDS AS WELL AS ANY OTHER FEDERAL, STATE, AND LOCAL CODES.
- CONTROL PANEL / CIRCUIT BREAKER INFORMATION:
 - SEE SPECIFICATION SHEET OR OWNERS MANUAL
 - ACCESSIBLE THROUGH CUSTOMER ACCESS ASSEMBLY DOOR ON REAR OF GENERATOR.
- REMOVE THE REAR ENCLOSURE COVER PANEL TO ACCESS THE STUB-UP AREAS AS FOLLOWS:
 - HIGH VOLTAGE CONNECTION INCLUDING AC LOAD LEAD CONDUIT CONNECTION NEUTRAL CONNECTION, BATTERY CHARGER 120 VOLT AC (0.5 AMP MAX) CONNECTION.
 - LOW VOLTAGE CONNECTION INCLUDING TRANSFER SWITCH CONTROL WIRES.
- CENTER OF GRAVITY AND WEIGHT MAY CHANGE DUE TO UNIT OPTIONS.
- BOTTOM OF GENERATOR SET MUST BE ENCLOSED TO PREVENT PEST INTRUSION AND RECIRCULATION OF DISCHARGE AIR AND/OR IMPROPER COOLING AIR FLOW.
- EXHAUST SYSTEM MAXIMUM BACK PRESSURE: 24 INCHES H₂O.
- REFERENCE OWNERS MANUAL FOR LIFTING WARNINGS.
- MOUNTING BOLTS OR STUDS TO MOUNTING SURFACE SHALL BE 5/8-11 GRADE 5 (USE STANDARD SAE TORQUE SPECS)
- MUST ALLOW FREE FLOW OF INTAKE AIR, DISCHARGE AIR AND EXHAUST. SEE SPEC SHEET FOR MINIMUM AIR FLOW AND MAXIMUM RESTRICTION REQUIREMENTS.
- GENERATOR MUST BE INSTALLED SUCH THAT FRESH COOLING AIR IS AVAILABLE AND THAT DISCHARGE AIR FROM RADIATOR IS NOT RECIRCULATED.
- EXHAUST MUFFLER ENCLOSED WITHIN GENERATOR ENCLOSURE, REMOVE ENCLOSURE TO ACCESS EXHAUST MUFFLER.

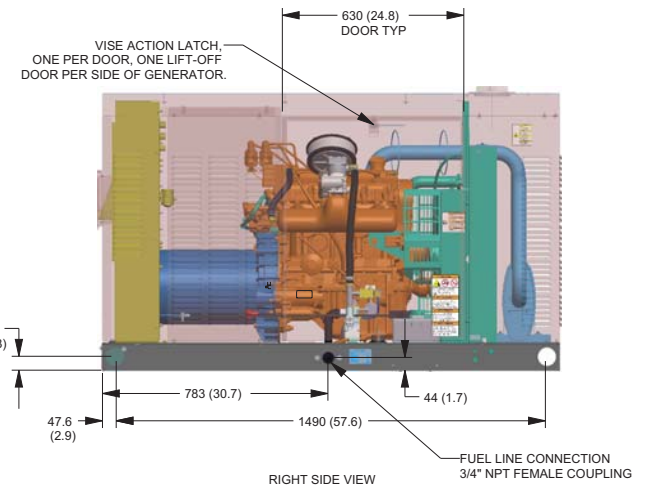
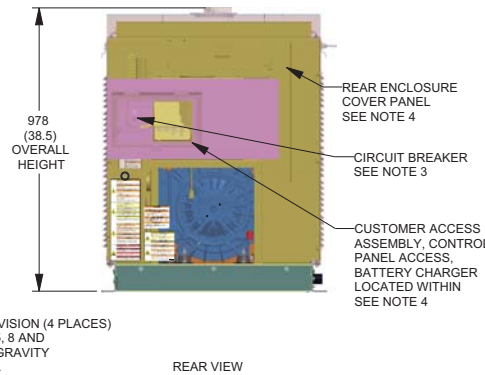
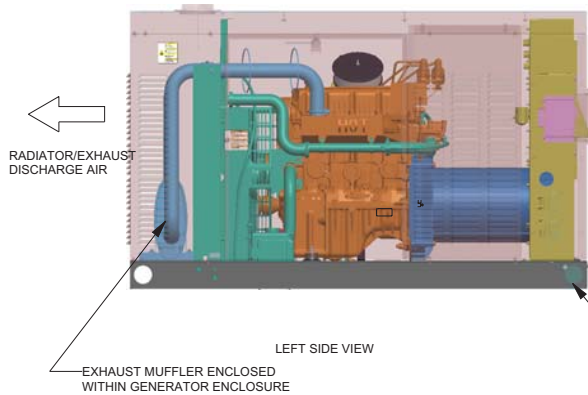

WEIGHT DATA				
ENGINE/KW	ENCLOSURE MATERIAL	WEIGHT GENSET ONLY KG [LBS]	WEIGHT SHIPPING SKID KG [LBS]	SHIPPING WEIGHT KG [LBS]
1.5L/25KW	ST	392 [865]	30 [66]	422 [931]
1.5L/30KW	ST	406 [895]	30 [66]	436 [961]
1.5L/25KW	AL	352 [777]	30 [66]	382 [843]
1.5L/30KW	AL	366 [807]	30 [66]	396 [873]

DIMENSIONS: MM [INCH]

0K8420-A 25/30 kW (1.5 L) Page 2 of 2

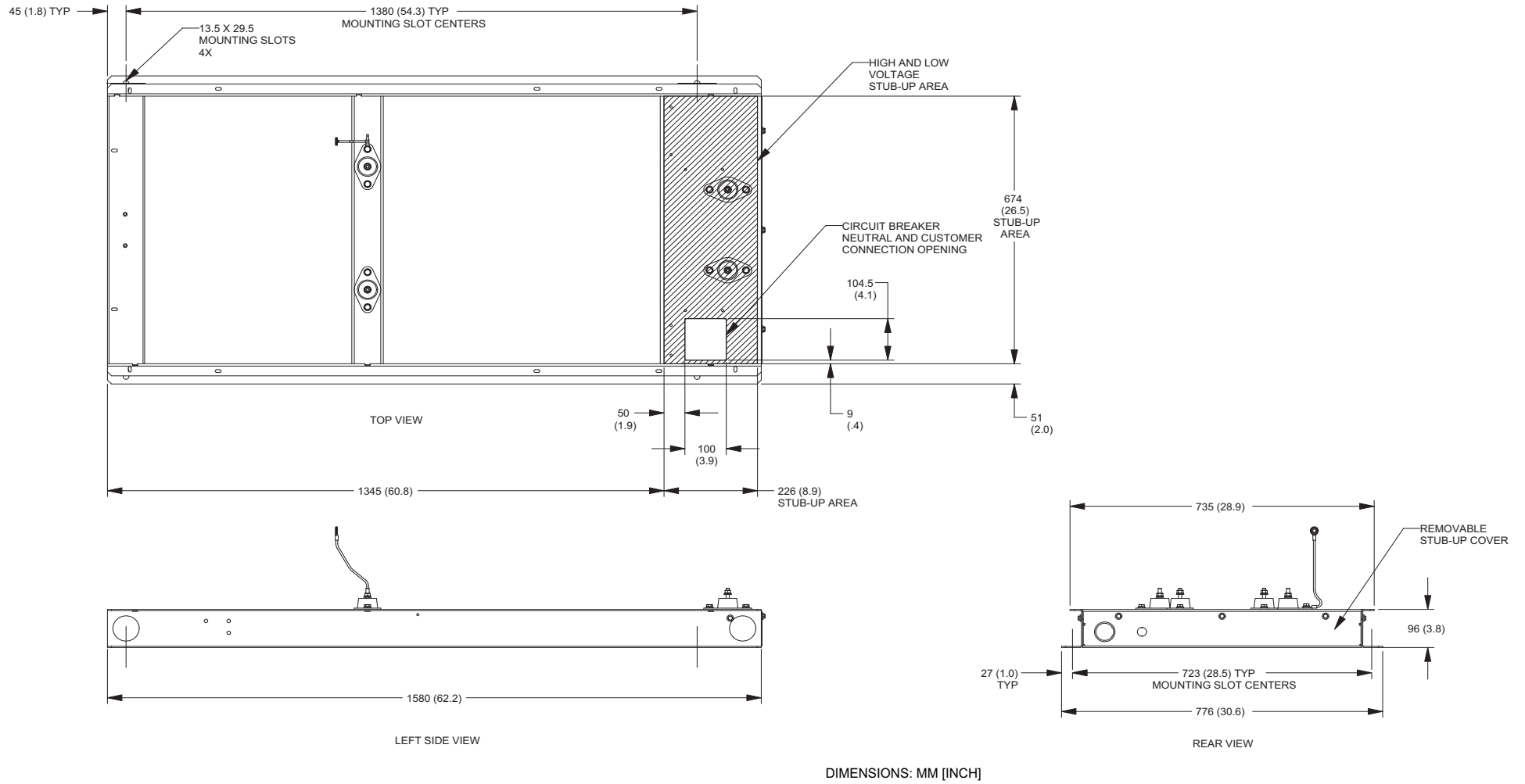

9.2 — 0K8624-A 22/27 kW (2.4 L) Page 1 of 2

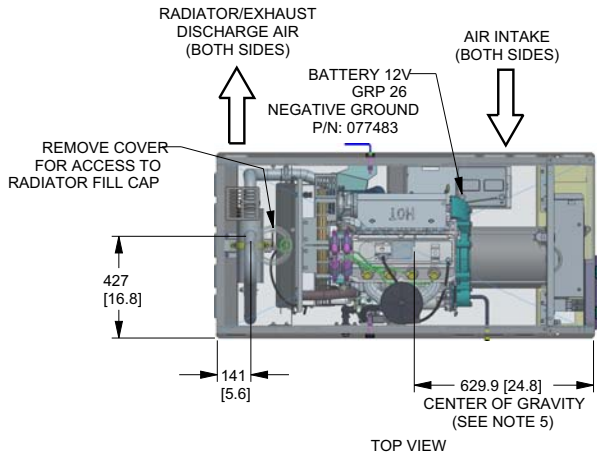

SERVICE ITEM	2.4L
OIL FILL CAP	EITHER SIDE
OIL DIP STICK	RIGHT SIDE
OIL FILTER	RIGHT SIDE
OIL DRAIN HOSE	LEFT SIDE
RADIATOR DRAIN	LEFT SIDE
COOLANT RECOVERY BOTTLE	LEFT SIDE
RADIATOR FILL CAP	ROOF TOP
AIR CLEANER ELEMENT	LEFT SIDE
SPARK PLUGS	LEFT SIDE
MUFFLER	SEE NOTE 11
DRIVE BELT	EITHER SIDE
FAN BELT	SEE NOTE 11
BATTERY	LEFT SIDE

REFERENCE OWNERS MANUAL FOR PERIODIC REPLACEMENT PART LISTINGS.

NOTES:

- MINIMUM RECOMMENDED CONCRETE PAD SIZE: 1092 (43") WIDE X 1885 (74.2") LONG. REFERENCE INSTALLATION GUIDE SUPPLIED WITH UNIT FOR CONCRETE PAD GUIDELINES.
- ALLOW SUFFICIENT ROOM ON ALL SIDES OF THE GENERATOR FOR MAINTENANCE AND SERVICING. THIS UNIT MUST BE INSTALLED IN ACCORDANCE WITH CURRENT APPLICABLE NFPA 37 AND NFPA 70 STANDARDS AS WELL AS ANY OTHER FEDERAL, STATE, AND LOCAL CODES.
- CONTROL PANEL / CIRCUIT BREAKER INFORMATION:
 - SEE SPECIFICATION SHEET OR OWNERS MANUAL
 - ACCESSIBLE THROUGH CUSTOMER ACCESS ASSEMBLY DOOR ON REAR OF GENERATOR.
- REMOVE THE REAR ENCLOSURE COVER PANEL TO ACCESS THE STUB-UP AREAS AS FOLLOWS:
 - HIGH VOLTAGE CONNECTION INCLUDING AC LOAD LEAD CONDUIT CONNECTION
 - NEUTRAL CONNECTION, BATTERY CHARGER 120 VOLT AC (0.5 AMP MAX) CONNECTION.
 - LOW VOLTAGE CONNECTION INCLUDING TRANSFER SWITCH CONTROL WIRES.
- CENTER OF GRAVITY AND WEIGHT MAY CHANGE DUE TO UNIT OPTIONS.
- BOTTOM OF GENERATOR SET MUST BE ENCLOSED TO PREVENT PEST INTRUSION AND RECIRCULATION OF DISCHARGE AIR AND/OR IMPROPER COOLING AIR FLOW.
- REFERENCE OWNERS MANUAL FOR LIFTING WARNINGS.
- MOUNTING BOLTS OR STUDS TO MOUNTING SURFACE SHALL BE 5/8-11 GRADE 5 (USE STANDARD SAE TORQUE SPECS)
- MUST ALLOW FREE FLOW OF INTAKE AIR, DISCHARGE AIR AND EXHAUST. SEE SPEC SHEET FOR MINIMUM AIR FLOW AND MAXIMUM RESTRICTION REQUIREMENTS.
- GENERATOR MUST BE INSTALLED SUCH THAT FRESH COOLING AIR IS AVAILABLE AND THAT DISCHARGE AIR FROM RADIATOR IS NOT RECIRCULATED.
- EXHAUST MUFFLER AND FAN BELT ENCLOSED WITHIN GENERATOR ENCLOSURE, REMOVE FRONT PANEL TO ACCESS.

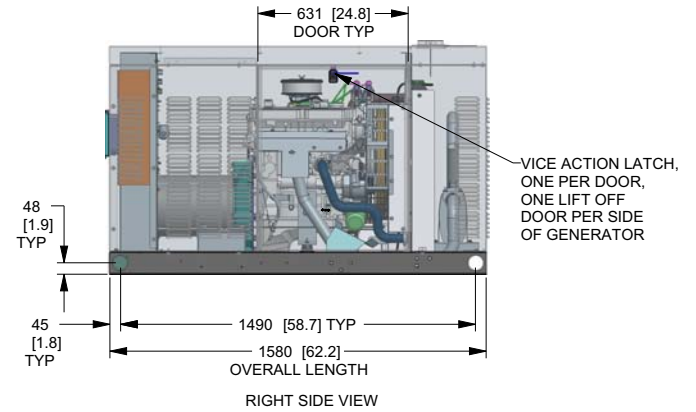
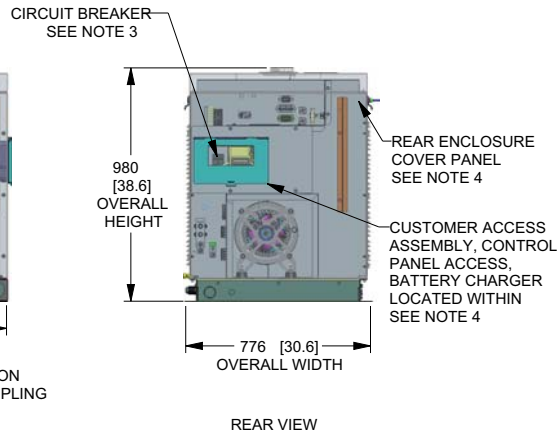
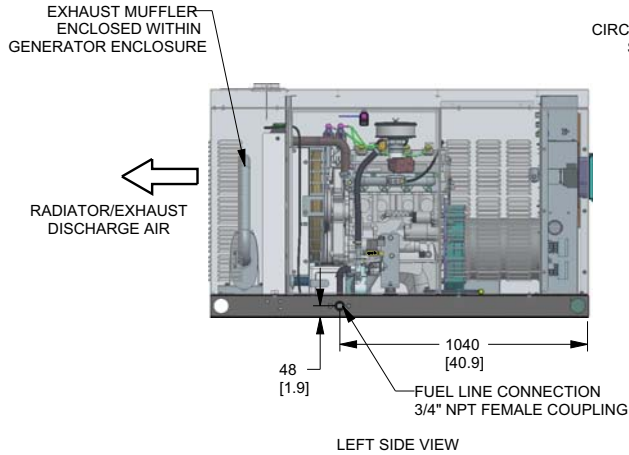

WEIGHT DATA				
ENGINE/KW	ENCLOSURE MATERIAL	WEIGHT GENSET ONLY KG [LBS]	WEIGHT SHIPPING SKID KG [LBS]	SHIPPING WEIGHT KG [LBS]
2.4L 22KW	AL	410.5 [905]	30 [66]	440 [971]
2.4L 27KW	AL	426 [940]	30 [66]	456 [1006]

DIMENSIONS: MM [INCH]

0K8624-A 22/27 kW (2.4 L) Page 2 of 2

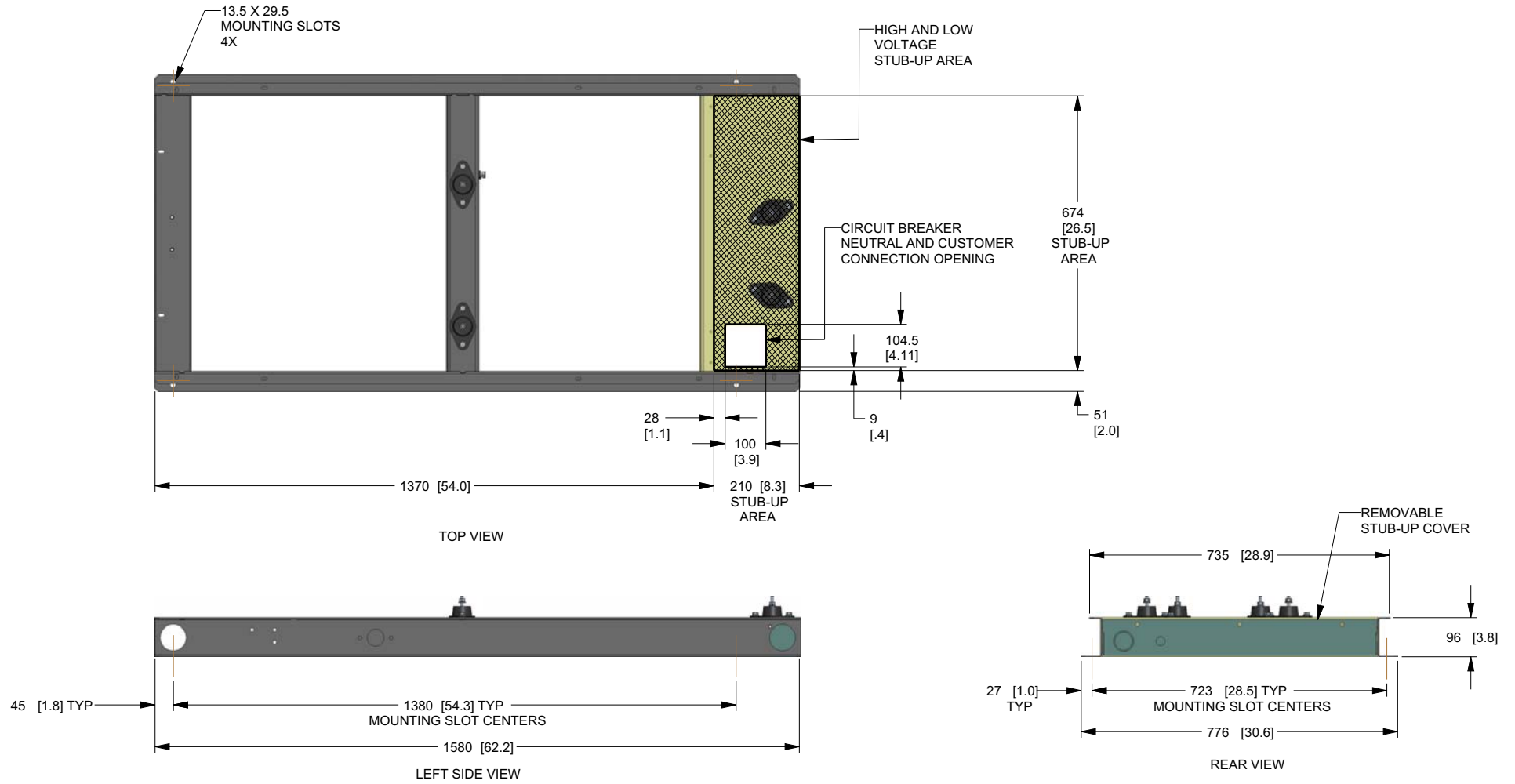

DIMENSIONS: MM [INCH]

9.3 — 0K8636-A 36/45 kW (2.4 L) Page 1 of 2

REMOVE COVER FOR ACCESS TO RADIATOR FILL CAP

RADIATOR/EXHAUST DISCHARGE AIR (BOTH SIDES)

AIR INTAKE (BOTH SIDES)

443 [17.5]

187 [7.4]

BATTERY 12V GROUP 26 NEGATIVE GROUND P/N: 077483

749.3 [29.5]

CENTER OF GRAVITY (SEE NOTE 5)

REMOVE COVER FOR ACCESS TO LUBE OIL MAINTAINER SUPPLY TANK
REFERENCE OWNERS MANUAL

TOP VIEW

EXHAUST MUFFLER ENCLOSED WITHIN GENERATOR ENCLOSURE

RADIATOR/EXHAUST DISCHARGE AIR

50 [2.0]

1000 [39.4]

FUEL LINE CONNECTION 3/4" NPT FEMALE COUPLING

LEFT SIDE VIEW

CIRCUIT BREAKER SEE NOTE 3

1170 [46.1]

OVERALL HEIGHT

888 [35.0]

OVERALL WIDTH

REAR VIEW

REAR ENCLOSURE COVER PANEL SEE NOTE 4

CUSTOMER ACCESS ASSEMBLY, CONTROL PANEL ACCESS, BATTERY CHARGER LOCATED WITHIN SEE NOTE 4

58 [2.3] TYP

46.5 [1.83]

758 [29.8]

DOOR TYP

VICE ACTION LATCH, ONE PER DOOR, ONE LIFT OFF DOOR PER SIDE OF GENERATOR

1857 [73.1] TYP

1950 [76.8]

OVERALL LENGTH

RIGHT SIDE VIEW

WEIGHT DATA				
ENGINE/KW	ENCLOSURE MATERIAL	WEIGHT GENSET ONLY KG [LBS]	WEIGHT SHIPPING SKID KG [LBS]	SHIPPING WEIGHT KG [LBS]
2.4L 36KW	ST	569 [1255]	44 [98]	613 [1353]
2.4L 36KW	AL	545 [1202]	44 [98]	590 [1300]
2.4L 45KW	ST	596 [1313]	44 [98]	640 [1411]
2.4L 45KW	AL	572 [1260]	44 [98]	616 [1358]

DIMENSIONS: MM [INCH]

SERVICE ITEM	2.4L
OIL FILL CAP	EITHER SIDE
OIL DIP STICK	RIGHT SIDE
OIL FILTER	RIGHT SIDE
OIL DRAIN HOSE	RIGHT SIDE
RADIATOR DRAIN HOSE	LEFT SIDE
COOLANT RECOVERY BOTTLE	LEFT SIDE
RADIATOR FILL CAP	ROOF TOP
AIR CLEANER ELEMENT	LEFT SIDE
SPARK PLUGS	LEFT SIDE
MUFFLER	SEE NOTE 11
DRIVE BELT	EITHER SIDE
FAN BELT	SEE NOTE 11
BATTERY	LEFT SIDE
LUBE OIL MAINTAINER SUPPLY TANK FILL CAP	ROOF TOP

REFERENCE OWNERS MANUAL FOR PERIODIC REPLACEMENT PART LISTINGS.

NOTES:

- MINIMUM RECOMMENDED CONCRETE PAD SIZE: 1194MM (47") WIDE X 2256MM (88.8") LONG. REFERENCE INSTALLATION GUIDE SUPPLIED WITH UNIT FOR CONCRETE PAD GUIDELINES.
- ALLOW SUFFICIENT ROOM ON ALL SIDES OF THE GENERATOR FOR MAINTENANCE AND SERVICING. THIS UNIT MUST BE INSTALLED IN ACCORDANCE WITH CURRENT APPLICABLE NFPA 37 AND NFPA 70 STANDARDS AS WELL AS ANY OTHER FEDERAL, STATE, AND LOCAL CODES.
- CONTROL PANEL / CIRCUIT BREAKER INFORMATION:
 - SEE SPECIFICATION SHEET OR OWNERS MANUAL
 - ACCESSIBLE THROUGH CUSTOMER ACCESS ASSEMBLY DOOR ON REAR OF GENERATOR.
- REMOVE THE REAR ENCLOSURE COVER PANEL TO ACCESS THE STUB-UP AREAS AS FOLLOWS:
 - HIGH VOLTAGE CONNECTION INCLUDING AC LOAD LEAD CONDUIT CONNECTION NEUTRAL CONNECTION, BATTERY CHARGER 120 VOLT AC (0.5 AMP MAX) CONNECTION.
 - LOW VOLTAGE CONNECTION INCLUDING TRANSFER SWITCH CONTROL WIRES.
- CENTER OF GRAVITY AND WEIGHT MAY CHANGE DUE TO UNIT OPTIONS.
- BOTTOM OF GENERATOR SET MUST BE ENCLOSED TO PREVENT PEST INTRUSION AND RECIRCULATION OF DISCHARGE AIR AND/OR IMPROPER COOLING AIR FLOW.
- REFERENCE OWNERS MANUAL FOR LIFTING WARNINGS.
- MOUNTING BOLTS OR STUDS TO MOUNTING SURFACE SHALL BE 5/8-11 GRADE 5 (USE STANDARD SAE TORQUE SPECS)
- MUST ALLOW FREE FLOW OF INTAKE AIR, DISCHARGE AIR AND EXHAUST. SEE SPEC SHEET FOR MINIMUM AIR FLOW AND MAXIMUM RESTRICTION REQUIREMENTS.
- GENERATOR MUST BE INSTALLED SUCH THAT FRESH COOLING AIR IS AVAILABLE AND THAT DISCHARGE AIR FROM RADIATOR IS NOT RECIRCULATED.
- EXHAUST MUFFLER AND FAN BELT ENCLOSED WITHIN GENERATOR ENCLOSURE, REMOVE FRONT PANEL TO ACCESS.

0K8636-A 36/45 kW (2.4 L) Page 2 of 2

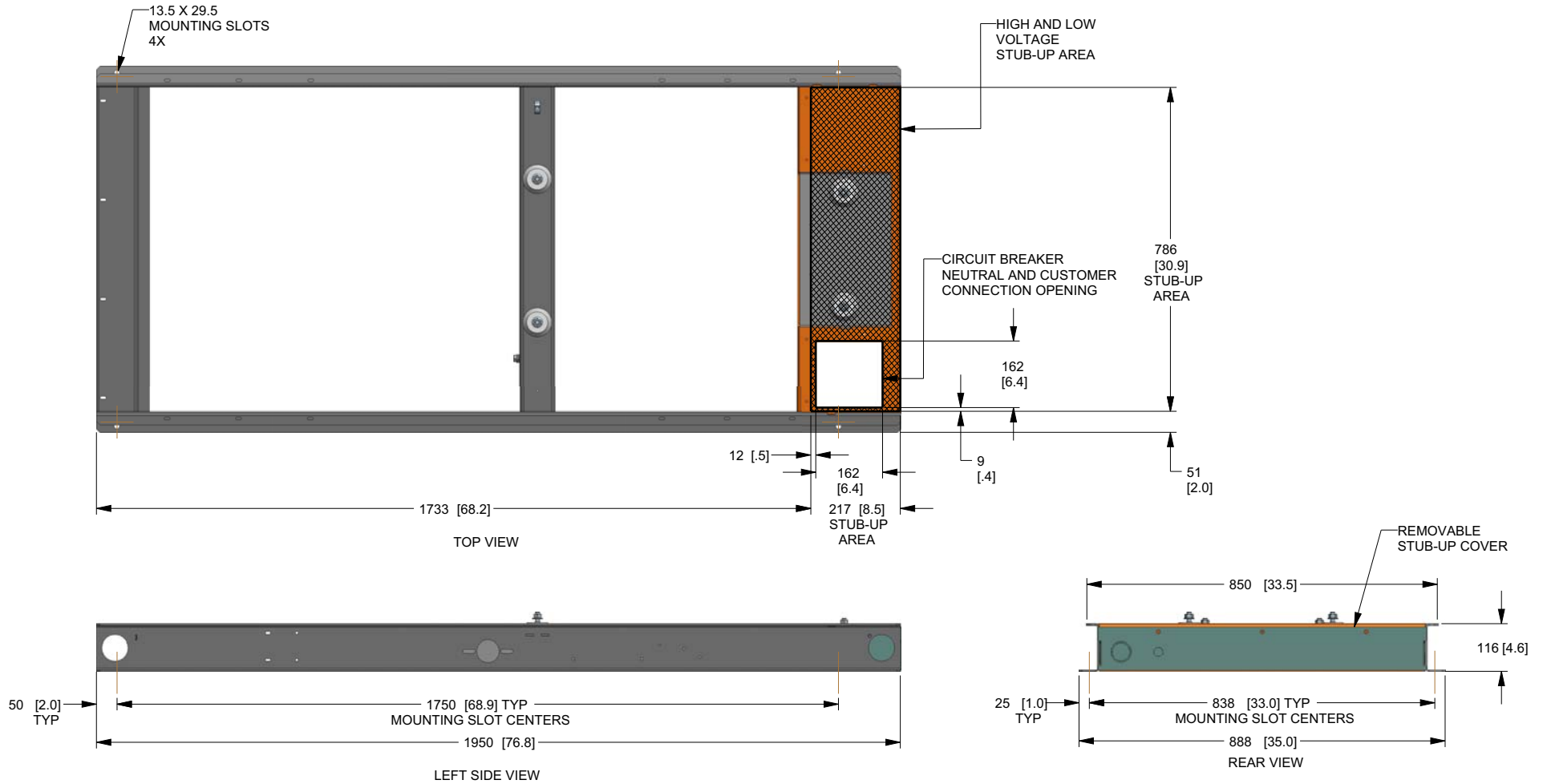

DIMENSIONS: MM [INCH]

9.4 — 0K9268-A 32/38 kW (2.4 L) Page 1 of 2

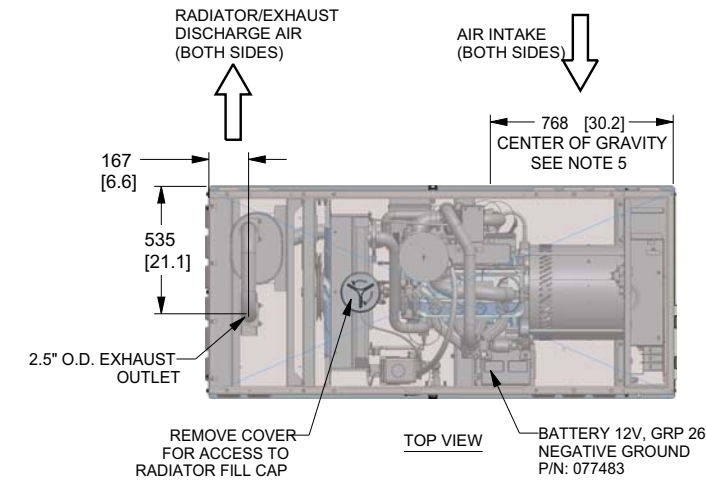

SERVICE ITEM	2.4L
OIL FILL CAP	EITHER SIDE
OIL DIP STICK	RIGHT SIDE
OIL FILTER	RIGHT SIDE
OIL DRAIN HOSE	RIGHT SIDE
RADIATOR DRAIN HOSE	LEFT SIDE
COOLANT RECOVERY BOTTLE	LEFT SIDE
RADIATOR FILL CAP ACCESS	ROOF TOP
AIR CLEANER ELEMENT	RIGHT SIDE
SPARK PLUGS	LEFT SIDE
MUFFLER	SEE NOTE 11
DRIVE BELT	EITHER SIDE
FAN BELT	SEE NOTE 11
BATTERY	LEFT SIDE

REFERENCE OWNERS MANUAL FOR PERIODIC REPLACEMENT PART LISTINGS.

NOTES:

- MINIMUM RECOMMENDED CONCRETE PAD SIZE: 1194 (47") WIDE X 2255 (88.8") LONG. REFERENCE INSTALLATION GUIDE SUPPLIED WITH UNIT FOR CONCRETE PAD GUIDELINES.
- ALLOW SUFFICIENT ROOM ON ALL SIDES OF THE GENERATOR FOR MAINTENANCE AND SERVICING. THIS UNIT MUST BE INSTALLED IN ACCORDANCE WITH CURRENT APPLICABLE NFPA 37 AND NFPA 70 STANDARDS AS WELL AS ANY OTHER FEDERAL, STATE, AND LOCAL CODES.
- CONTROL PANEL / CIRCUIT BREAKER INFORMATION:
 - SEE SPECIFICATION SHEET OR OWNERS MANUAL
 - ACCESSIBLE THROUGH CUSTOMER ACCESS ASSEMBLY DOOR ON REAR OF GENERATOR.
- REMOVE THE REAR ENCLOSURE COVER PANEL TO ACCESS THE STUB-UP AREAS AS FOLLOWS:
 - HIGH VOLTAGE CONNECTION INCLUDING AC LOAD LEAD CONDUIT CONNECTION, NEUTRAL CONNECTION, AND BATTERY CHARGER 120 VOLT AC (0.5 AMP MAX) CONNECTION.
 - LOW VOLTAGE CONNECTION INCLUDING TRANSFER SWITCH CONTROL WIRES.
- CENTER OF GRAVITY AND WEIGHT MAY CHANGE DUE TO UNIT OPTIONS.
- BOTTOM OF GENERATOR SET MUST BE ENCLOSED TO PREVENT PEST INTRUSION AND RECIRCULATION OF DISCHARGE AIR AND/OR IMPROPER COOLING AIR FLOW.
- REFERENCE OWNERS MANUAL FOR LIFTING WARNINGS.
- MOUNTING BOLTS OR STUDS TO MOUNTING SURFACE SHALL BE 5/8-11 GRADE 5 (USE STANDARD SAE TORQUE SPECS)
- MUST ALLOW FREE FLOW OF INTAKE AIR, DISCHARGE AIR AND EXHAUST. SEE SPEC SHEET FOR MINIMUM AIR FLOW AND MAXIMUM RESTRICTION REQUIREMENTS.
- GENERATOR MUST BE INSTALLED SUCH THAT FRESH COOLING AIR IS AVAILABLE AND THAT DISCHARGE AIR FROM RADIATOR IS NOT RECIRCULATED.
- EXHAUST MUFFLER AND FAN BELT ARE ENCLOSED WITHIN GENERATOR ENCLOSURE, REMOVE FRONT PANEL TO ACCESS.

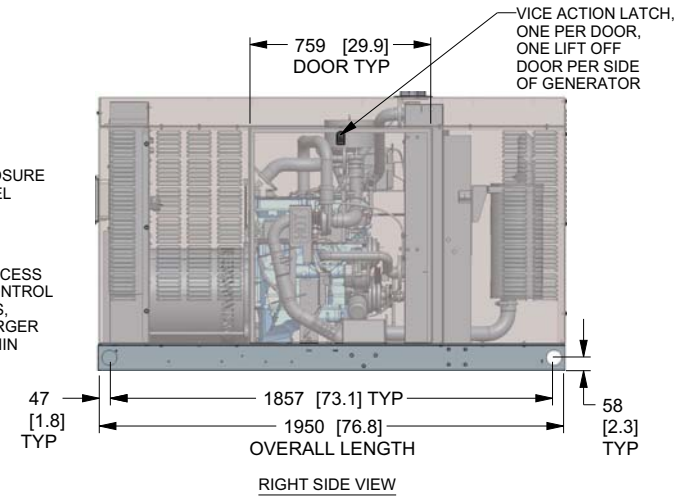
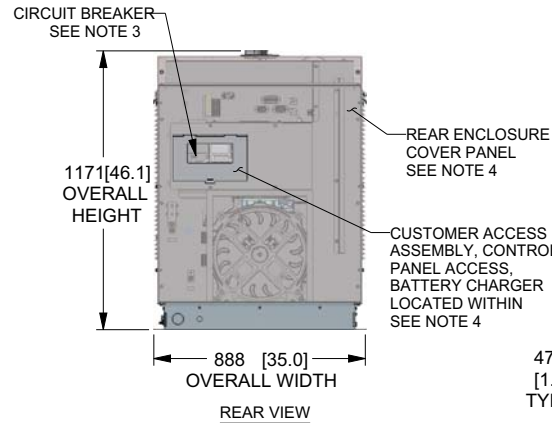
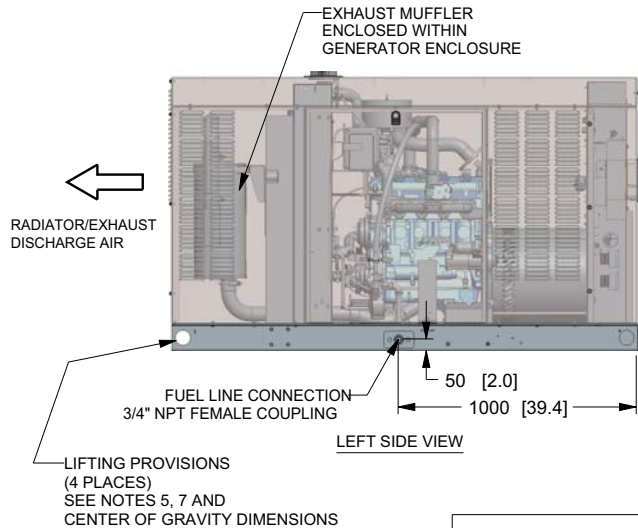

WEIGHT DATA				
ENGINE/KW	ENCLOSURE MATERIAL	WEIGHT GENSET ONLY KG [LBS]	WEIGHT SHIPPING SKID KG [LBS]	SHIPPING WEIGHT KG [LBS]
2.4L 32KW	AL	556 [1225]	44 [98]	600 [1323]
2.4L 38KW	AL	560 [1235]	44 [98]	605 [1333]

DIMENSIONS: MM [INCH]

0K9268-A 32/38 kW (2.4 L) Page 2 of 2

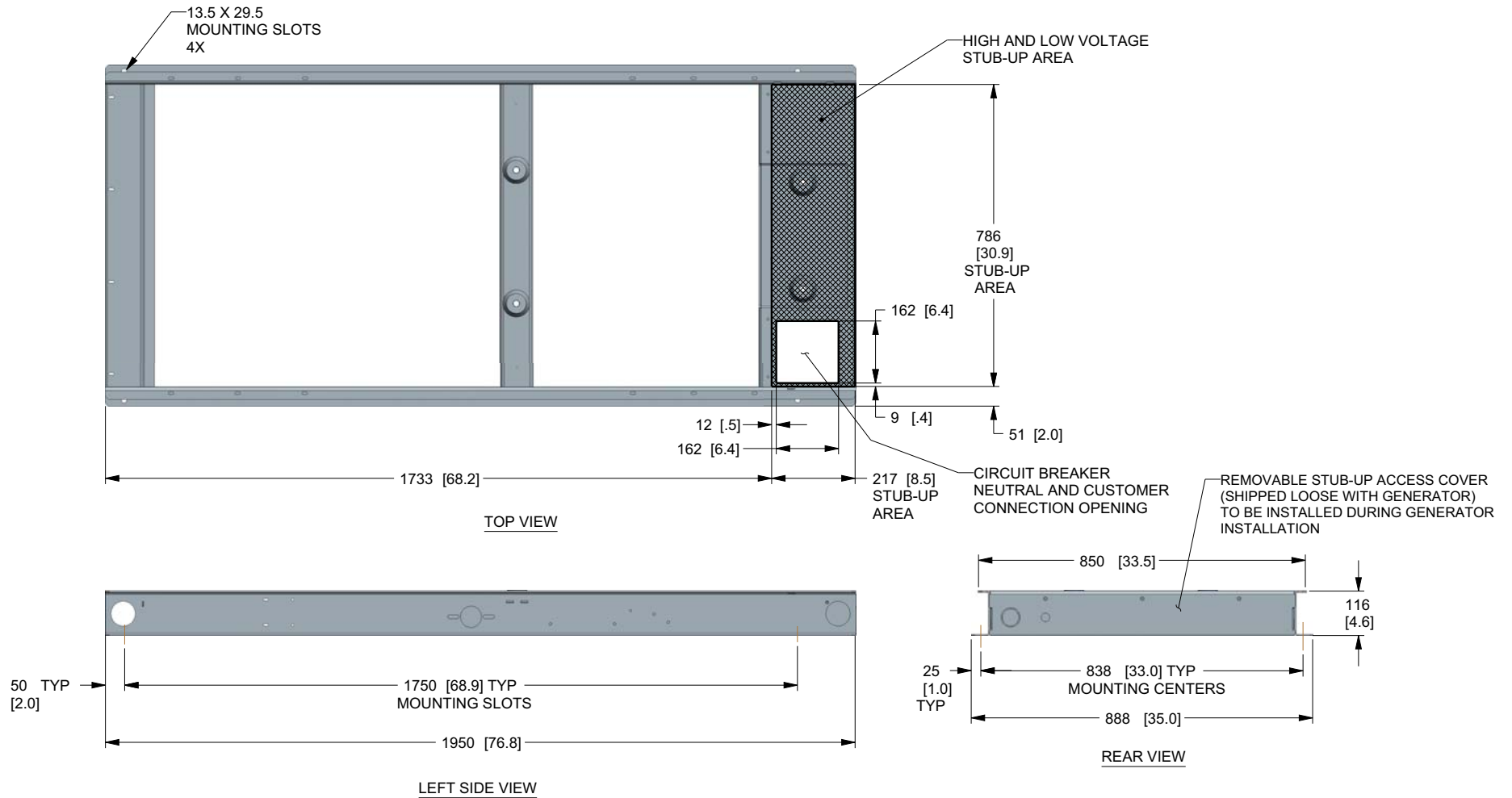

DIMENSIONS: MM [INCH]

9.5 — 0L2090-A 60 kW (2.4 L) Page 1 of 2

TOP VIEW

SERVICE ITEM	2.4L
OIL FILL CAP	EITHER SIDE
OIL DIP STICK	RIGHT SIDE
OIL FILTER	LEFT SIDE
OIL DRAIN HOSE	RIGHT SIDE
RADIATOR DRAIN HOSE	LEFT SIDE
COOLANT RECOVERY BOTTLE	LEFT SIDE
RADIATOR FILL CAP	ROOF TOP
AIR CLEANER ELEMENT	LEFT SIDE
SPARK PLUGS	LEFT SIDE
MUFFLER	SEE NOTE 11
DRIVE BELT	EITHER SIDE
FAN BELT	SEE NOTE 11
BATTERY	LEFT SIDE
LUBE OIL MAINTAINER SUPPLY TANK FILL CAP	ROOF TOP

REFERENCE OWNERS MANUAL FOR PERIODIC REPLACEMENT PART LISTINGS.

REMOVE COVER FOR ACCESS TO LUBE OIL MAINTAINER SUPPLY TANK
REFERENCE OWNERS MANUAL

LEFT SIDE VIEW

REAR VIEW

RIGHT SIDE VIEW

WEIGHT DATA				
ENGINE/KW	ENCLOSURE MATERIAL	WEIGHT GENSET ONLY KG [LBS]	WEIGHT SHIPPING SKID KG [LBS]	SHIPPING WEIGHT KG [LBS]
2.4L 60KW	ST	582 [1283]	44 [98]	626 [1381]
2.4L 60KW	AL	558 [1230]	44 [98]	602 [1328]

DIMENSIONS: MM [INCH]

NOTES:

- MINIMUM RECOMMENDED CONCRETE PAD SIZE: 1194MM (47") WIDE X 2256MM (88.8") LONG. REFERENCE INSTALLATION GUIDE SUPPLIED WITH UNIT FOR CONCRETE PAD GUIDELINES.
- ALLOW SUFFICIENT ROOM ON ALL SIDES OF THE GENERATOR FOR MAINTENANCE AND SERVICING. THIS UNIT MUST BE INSTALLED IN ACCORDANCE WITH CURRENT APPLICABLE NFPA 37 AND NFPA 70 STANDARDS AS WELL AS ANY OTHER FEDERAL, STATE, AND LOCAL CODES.
- CONTROL PANEL / CIRCUIT BREAKER INFORMATION:
 - SEE SPECIFICATION SHEET OR OWNERS MANUAL
 - ACCESSIBLE THROUGH CUSTOMER ACCESS ASSEMBLY DOOR ON REAR OF GENERATOR.
- REMOVE THE REAR ENCLOSURE COVER PANEL TO ACCESS THE STUB-UP AREAS AS FOLLOWS:
 - HIGH VOLTAGE CONNECTION INCLUDING AC LOAD LEAD CONDUIT CONNECTION NEUTRAL CONNECTION, BATTERY CHARGER 120 VOLT AC (0.5 AMP MAX) CONNECTION.
 - LOW VOLTAGE CONNECTION INCLUDING TRANSFER SWITCH CONTROL WIRES.
- CENTER OF GRAVITY AND WEIGHT MAY CHANGE DUE TO UNIT OPTIONS.
- BOTTOM OF GENERATOR SET MUST BE ENCLOSED TO PREVENT PEST INTRUSION AND RECIRCULATION OF DISCHARGE AIR AND/OR IMPROPER COOLING AIR FLOW.
- REFERENCE OWNERS MANUAL FOR LIFTING WARNINGS.
- MOUNTING BOLTS OR STUDS TO MOUNTING SURFACE SHALL BE 5/8-11 GRADE 5 (USE STANDARD SAE TORQUE SPECS)
- MUST ALLOW FREE FLOW OF INTAKE AIR, DISCHARGE AIR AND EXHAUST. SEE SPEC SHEET FOR MINIMUM AIR FLOW AND MAXIMUM RESTRICTION REQUIREMENTS.
- GENERATOR MUST BE INSTALLED SUCH THAT FRESH COOLING AIR IS AVAILABLE AND THAT DISCHARGE AIR FROM RADIATOR IS NOT RECIRCULATED.
- EXHAUST MUFFLER AND FAN BELT ENCLOSED WITHIN GENERATOR ENCLOSURE, REMOVE FRONT PANEL TO ACCESS.

0L2090-A 60 kW (2.4 L) Page 2 of 2

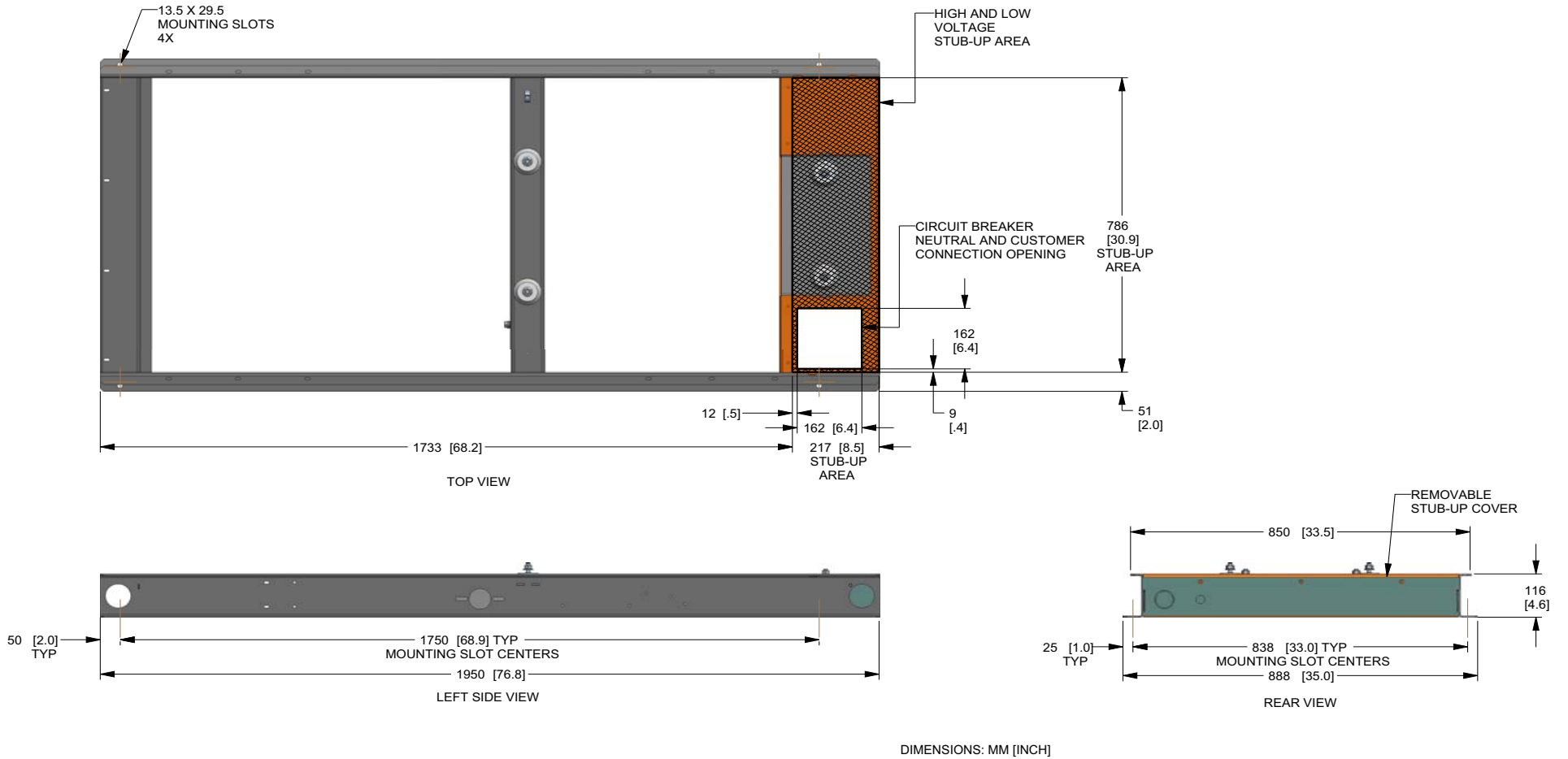

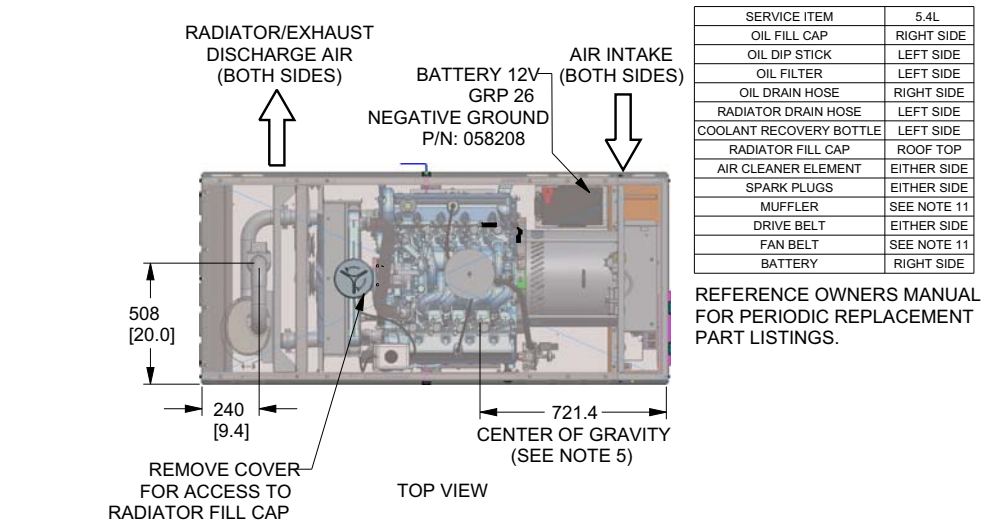

SERVICE ITEM	5.4L
OIL FILL CAP	RIGHT SIDE
OIL DIP STICK	LEFT SIDE
OIL FILTER	LEFT SIDE
OIL DRAIN HOSE	RIGHT SIDE
RADIATOR DRAIN HOSE	LEFT SIDE
COOLANT RECOVERY BOTTLE	LEFT SIDE
RADIATOR FILL CAP	ROOF TOP
AIR CLEANER ELEMENT	EITHER SIDE
SPARK PLUGS	EITHER SIDE
MUFFLER	SEE NOTE 11
DRIVE BELT	EITHER SIDE
FAN BELT	SEE NOTE 11
BATTERY	RIGHT SIDE

REFERENCE OWNERS MANUAL FOR PERIODIC REPLACEMENT PART LISTINGS.

NOTES:

- MINIMUM RECOMMENDED CONCRETE PAD SIZE: 1194 (47") WIDE X 2256 (88.8") LONG. REFERENCE INSTALLATION GUIDE SUPPLIED WITH UNIT FOR CONCRETE PAD GUIDELINES.
- ALLOW SUFFICIENT ROOM ON ALL SIDES OF THE GENERATOR FOR MAINTENANCE AND SERVICING. THIS UNIT MUST BE INSTALLED IN ACCORDANCE WITH CURRENT APPLICABLE NFPA 37 AND NFPA 70 STANDARDS AS WELL AS ANY OTHER FEDERAL, STATE, AND LOCAL CODES.
- CONTROL PANEL / CIRCUIT BREAKER INFORMATION:
 - SEE SPECIFICATION SHEET OR OWNERS MANUAL
 - ACCESSIBLE THROUGH CUSTOMER ACCESS ASSEMBLY DOOR ON REAR OF GENERATOR.
- REMOVE THE REAR ENCLOSURE COVER PANEL TO ACCESS THE STUB-UP AREAS AS FOLLOWS:
 - HIGH VOLTAGE CONNECTION INCLUDING AC LOAD LEAD CONDUIT CONNECTION NEUTRAL CONNECTION, BATTERY CHARGER 120 VOLT AC (0.5 AMP MAX) CONNECTION.
 - LOW VOLTAGE CONNECTION INCLUDING TRANSFER SWITCH CONTROL WIRES.
- CENTER OF GRAVITY AND WEIGHT MAY CHANGE DUE TO UNIT OPTIONS.
- BOTTOM OF GENERATOR SET MUST BE ENCLOSED TO PREVENT PEST INTRUSION AND RECIRCULATION OF DISCHARGE AIR AND/OR IMPROPER COOLING AIR FLOW.
- REFERENCE OWNERS MANUAL FOR LIFTING WARNINGS.
- MOUNTING BOLTS OR STUDS TO MOUNTING SURFACE SHALL BE 5/8-11 GRADE 5 (USE STANDARD SAE TORQUE SPECS)
- MUST ALLOW FREE FLOW OF INTAKE AIR, DISCHARGE AIR AND EXHAUST. SEE SPEC SHEET FOR MINIMUM AIR FLOW AND MAXIMUM RESTRICTION REQUIREMENTS.
- GENERATOR MUST BE INSTALLED SUCH THAT FRESH COOLING AIR IS AVAILABLE AND THAT DISCHARGE AIR FROM RADIATOR IS NOT RECIRCULATED.
- EXHAUST MUFFLER AND FAN BELT ENCLOSED WITHIN GENERATOR ENCLOSURE, REMOVE FRONT PANEL TO ACCESS.

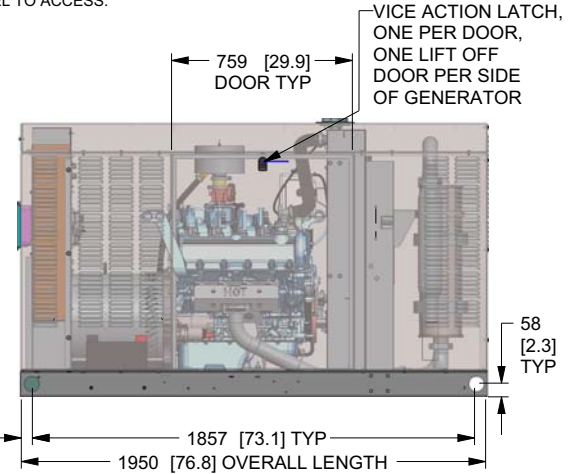
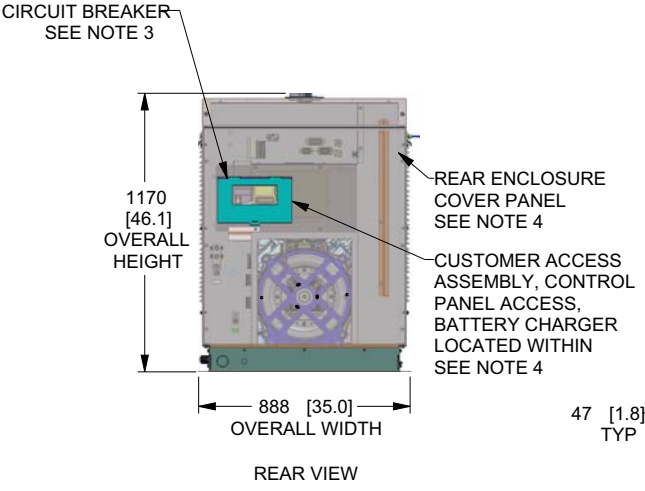
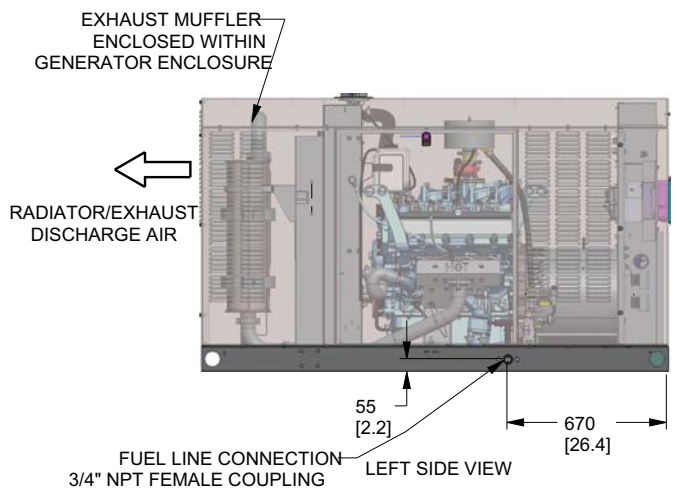

WEIGHT DATA				
ENGINE/KW	ENCLOSURE MATERIAL	WEIGHT GENSET ONLY KG [LBS]	WEIGHT SHIPPING SKID KG [LBS]	SHIPPING WEIGHT KG [LBS]
5.4L/48KW	AL	705 [1555]	44 [98]	750 [1653]

0K9243-A 48 kW (5.4 L) Page 1 of 2

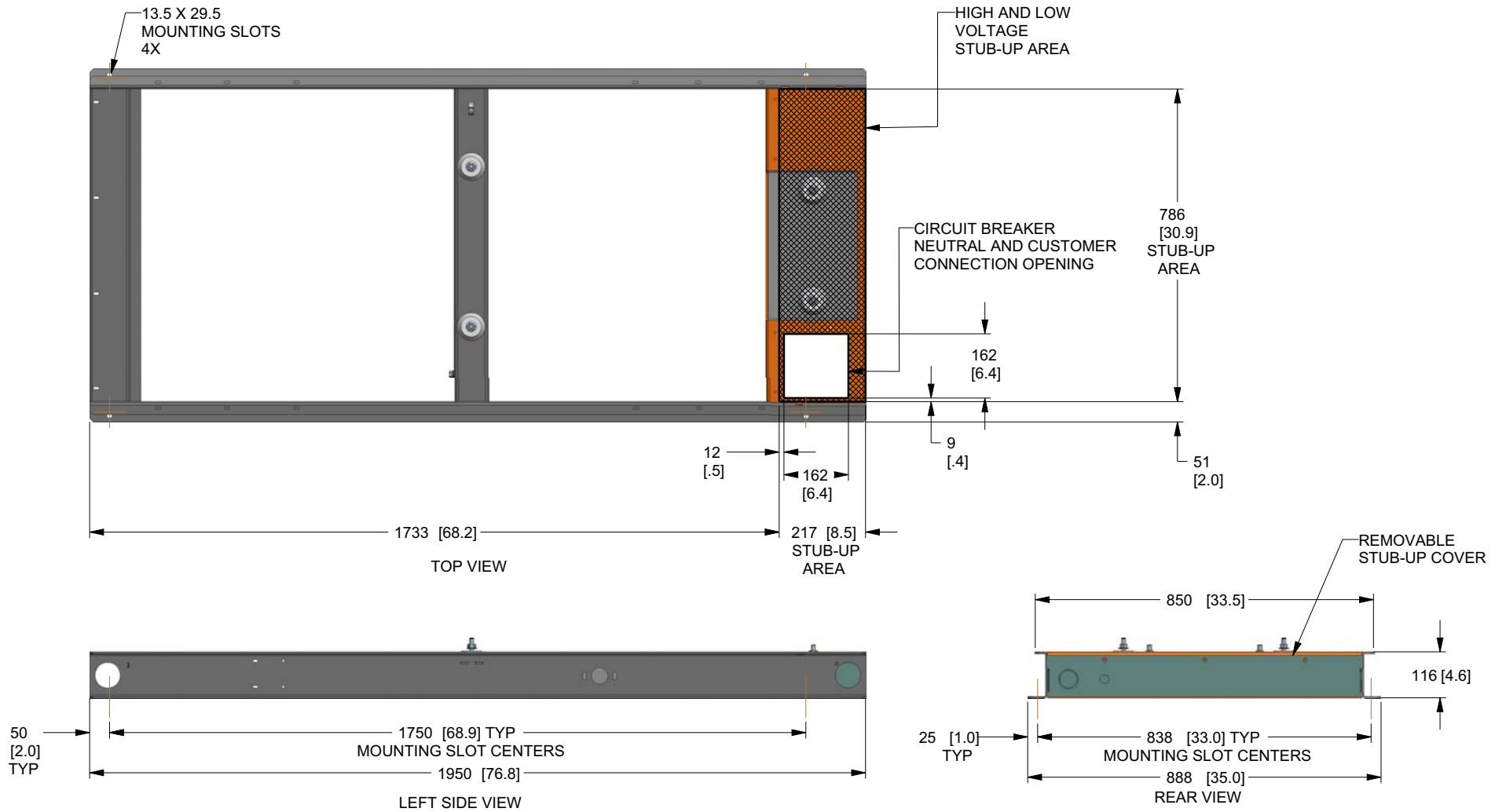

DIMENSIONS: MM [INCH]

Part No. 0K8419 Rev. A 02/23/2015 Printed in USA
©2015 Generac Power Systems, Inc. All rights reserved
Specifications are subject to change without notice.
No reproduction allowed in any form without prior written
consent from Generac Power Systems, Inc.

Generac Power Systems, Inc.
S45 W29290 Hwy. 59
Waukesha, WI 53189
1-888-GENERAC (1-888-436-3722)
generac.com