

# Flush Floor Mount Sleeve

Model: DH-20ZP and DH-20SS



by Honeywell

## Description

Zinc plated mild steel or stainless steel construction.  
Mounts to horizontal concrete or steel structures.  
Includes PVC sleeve liner.

## Materials

### FOR DH-20ZP:

**General Construction:** Welded Mild Steel

**Weld Certification:** AWS

**Base Material:** A-36 Steel Plate

**Material Structure:** Sch.40 Pipe

### Sleeve Bearing

**Material:** PVC Pipe  
ASTM-D-1785

### Thrust Bearing

**Material:** High Density

Polyethylene

**Finish (Steel Sleeves):** <125 uin machined or  
Cold Rolled

**Plating Specification:** ASTM Designation  
B633, Type II, SC2

### FOR DH-20SS:

**General Construction:** Welded Stainless Steel

**Weld Certification:** AWS

**Structure Material:** 304 Stainless Steel Plate

**Sleeve Material:** Sch. 40 Pipe  
ASTM-D-1785

### Sleeve Bearing

**Material:** PVC Pipe  
ASTM-D-1785

### Thrust Bearing

**Material:** High Density

Polyethylene

### Finish

(Stainless Sleeves): Sand Blasted



## Technical

**Rated Capacity:** 450lbs (204kg) working  
load limit @ minimum 4:1  
Design Factor

### Mast Moment

**Proof Load** 90,000 in-lbs (10,200 N.m)

**Mast Rotation** 360°

**DH-20ZP Weight** 24 lbs (10.9kg)

**DH-20SS Weight** 25 lbs (11.4kg)

**Note:** Sleeves are designed to withstand the proof load rating of all standard Miller DuraHoist masts.

## Mounting Requirements (Minimum)

The structure and mounting hardware must be capable of withstanding a 90,000 in-lbs (10,170Nm) moment and a 5,000lb (22.2kN) vertical load. Installation MUST be approved to local regulations by a qualified engineer.

## Application Restrictions

1. Sleeves are for use with approved masts and accessories ONLY.
2. System design factor depends on other system components and the configurations in which they are assembled. The minimum design factor for all standard MILLER DuraHoist mast and accessories is 4:1.
3. All welding is to be carried out by qualified personnel.
4. If base material does not meet minimum requirements, reinforcement MUST be added to meet minimum requirements.
5. Each installation MUST be approved to local standards by a qualified engineer.

# Flush Floor Mount Sleeve

Model: DH-20ZP and DH-20SS

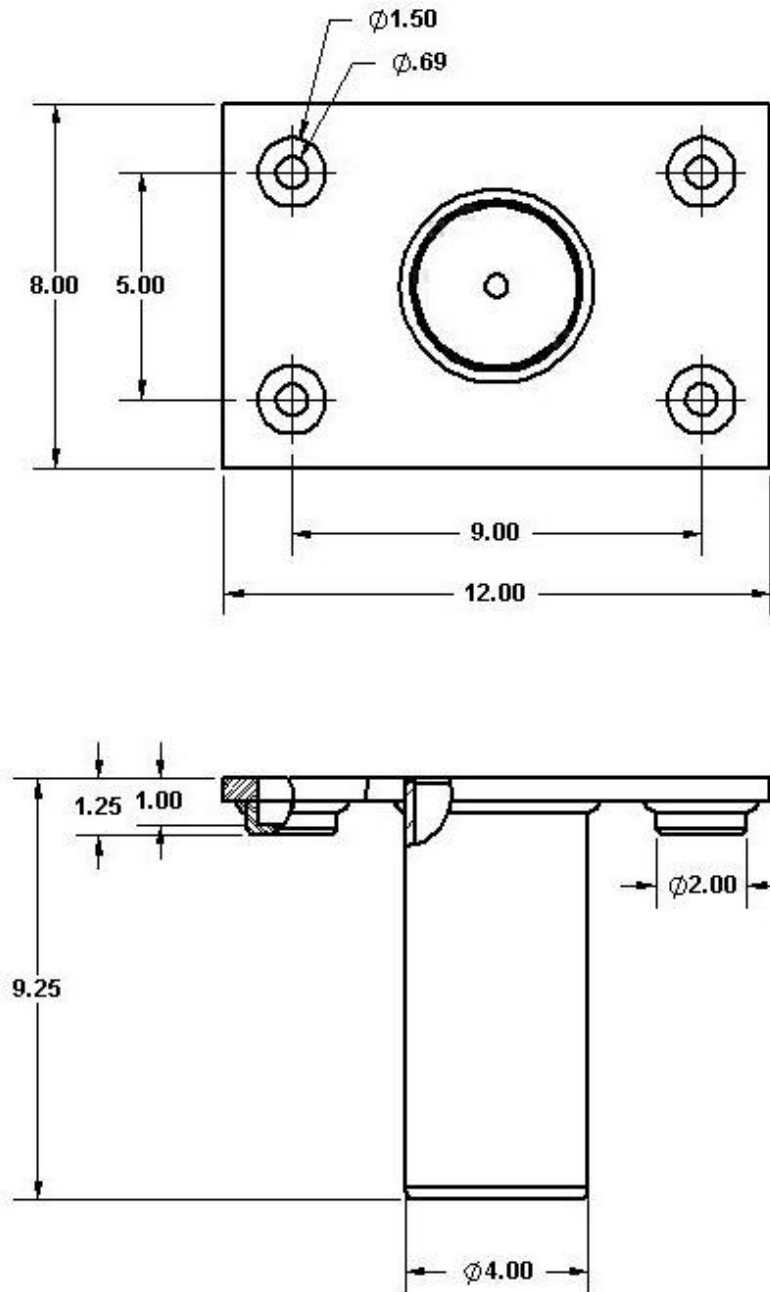

**MILLER**<sup>®</sup>

by Honeywell

Toll Free 800.873.5242 (press 4) • [hsptechsupport@honeywell.com](mailto:hsptechsupport@honeywell.com) • [www.millerfallprotection.com](http://www.millerfallprotection.com)

**⚠ WARNING!** THIS DOCUMENT PROVIDES AN OVERVIEW OF FALL PROTECTION **PRODUCTS** AVAILABLE FROM HONEYWELL AND CARE HAS BEEN TAKEN TO ASSURE THE ACCURACY OF THE DATA. IT DOES NOT PROVIDE IMPORTANT PRODUCT WARNINGS AND INSTRUCTIONS. HONEYWELL RECOMMENDS ALL USERS OF FALL PROTECTION EQUIPMENT UNDERGO THOROUGH TRAINING, AND THAT ALL WARNINGS AND INSTRUCTIONS PROVIDED WITH THE PRODUCTS BE THOROUGHLY READ AND UNDERSTOOD PRIOR TO EACH USE. FAILURE TO READ AND FOLLOW ALL PRODUCT WARNINGS AND INSTRUCTIONS COULD RESULT IN SERIOUS INJURY OR DEATH.