

Thermo Scientific
PrintMate AS
Operator Guide
A83810100 Issue 2



Company Information

© Copyright 2013. Thermo Fisher Scientific Inc. All rights reserved.

Thermo Fisher Scientific Inc. (Thermo Fisher Scientific) is the world leader in serving science, offering a unique combination of innovative technologies. Thermo Scientific is a brand name of Thermo Fisher Scientific.

All other trademarks are the property of Thermo Fisher Scientific and its subsidiaries.

Thermo Fisher Scientific makes every attempt to ensure that the information contained in this supporting document is correct and clearly stated, but does not accept responsibility for any errors or omissions. The development of Thermo Scientific products and services is an ongoing process. Please ensure that any published information you use as a reference is up to date and relates to the condition of the product. If necessary, check with your local Thermo Fisher Scientific representative.

This document may not, in whole or in part, be copied, photocopied, reproduced, translated, or converted to any electronic or other form without prior written consent of Thermo Fisher Scientific. All information contained in this manual is proprietary and confidential, and the exclusive property of Thermo Fisher Scientific and is protected by copyright.

Contact Addresses:



Thermo Shandon Limited (Trading as Thermo Fisher Scientific),

Tudor Road, Manor Park, Runcorn, WA7 1TA, UK

Tel: +44 (0) 1928 534 000; Fax: +44 (0) 1928 534 049;

Web: www.thermoscientific.com/pathology

USA Distributor:

Richard-Allan Scientific Co. Subsidiary of Thermo Fisher Scientific

4481 Campus Drive, Kalamazoo, MI 49008 USA

Tel: 1-800-522-7270; Fax: +1 269-372-2674;

Web: www.thermoscientific.com/pathology



This instrument conforms to the essential requirements of:

EMC Directive 2004/108/EC

Machinery Directive 2006/42/EC

Symbols

The following symbols and conventions may be used throughout this document and on the instrument:



This symbol is used on the equipment, or in a document, to indicate that instructions must be followed for safe and correct operation. If this symbol appears on the instrument, always refer to the operator guide.



This symbol is used on the equipment, or in a document, to indicate that there may be a biohazard associated with the instrument. Always act with common sense and be aware of the samples used. Take suitable precautions.



This symbol is used on the equipment, or in a document, to indicate that harmful chemicals are used. Refer to the Material Safety Data Sheets for the chemicals used. Always act with common sense and be aware of local laboratory procedures. Take suitable precautions.



This symbol indicates that a surface is hot. If this symbol appears on the instrument, always refer to the operator guide. Take suitable precautions.



Manufacturer.

Table of Contents

Safety Information.....	1
Introduction.....	1
General Safety	1
Environment	1
Warranty Statement	2
How To Use This Guide.....	3
Introduction.....	3
Chapter 1 - Introduction to PrintMate AS.....	3
Chapter 2 - Installation and Setup.....	3
Chapter 3 - Basic Operation	3
Chapter 4 - Troubleshooting.....	3
Chapter 5 - Cleaning and Maintenance	3
The PrintMate AS Product Range	5
Chapter 1 - Introducing PrintMate AS.....	7
Identification of Parts	8
PrintMate AS with doors closed.....	8
PrintMate AS with doors open	8
PrintMate AS external connections.....	9
PrintMate AS Print Head	9
List of parts	10
System Interaction.....	11
System Specification	12
Mechanical Specification	12
Electrical Specification.....	12
Environmental Specification.....	12
Chapter 2 - Installation and Setup.....	13
Installation and Setup.....	13
Setting Up PrintMate AS.....	14
Unpacking.....	15
Locating PrintMate AS.....	19
Electrical Connections and Start-Up Procedure.....	20
Connecting the Output Chutes	22
Changing the COM Port Settings	25
Chapter 3 - Basic Operation	29

Basic Operation	29
Hopper Types	30
Loading Cassette Tubes with Hopper Removed	31
Loading Cassette Tubes with Hopper In-Situ	34
Loading Single Cassettes Into Hoppers	36
Loading Hoppers Onto the Carousel	37
Changing the Foil Tape	39
Removing the Used Foil Tape	40
Fitting the Foil Tape Roll	41
Using the Touch Panel	45
Chapter 4 - Troubleshooting	47
Carousel Error	48
Fail to Detect Cassette	49
'Hopper Empty' Warning Displayed When Not Empty	50
Dispense Error	51
Dispense Lever Fails to Reset	52
Conveyor Error	53
Output Error	54
Output Drum Error	55
Loud Knocking Noise On Power-Up	56
Instrument Not Responding	57
Computer Not Responding	58
Tape Errors	59
Poor Print Quality	60
No Print	61
Part of Print is Missing	62
Lower Line of Print is Misaligned	63
Print is Faint	64
Print Rubs Off Cassette Easily	65
Barcodes Will Not Scan	66
Print Contains Incorrect Information	67
Chapter 5 - Cleaning and Maintenance	69
Cleaning and Maintenance	69
Cleaning Procedure	70
Changing Fuses	72
Appendices	75

Table of Contents

Appendix A - Spares and Accessories..... 75
 Spares and Accessories list..... 75
Appendix B - Repacking Instructions 76
Appendix C - Approved Cassette List 77
Index..... 78

Safety Information

Introduction

Thermo Fisher Scientific instruments are designed for convenient and reliable service; however, improper use or handling by a user may damage the instrument, or cause a hazard to health. The instrument must not be used in a manner not specified by Thermo Fisher Scientific. Correct maintenance procedures are essential for consistent performance. It is recommended that users secure a maintenance contract with our service department.

Any problems and queries should be referred to your Thermo Fisher Scientific service department.



The following sections contain important information for the safe setup and use of the instrument, and should be read and understood by the user before using the instrument.

General Safety



- This instrument, as supplied, conforms to IEC 61010-1; however, the addition of chemicals introduces potential hazards. Good Laboratory Practice must be employed and consideration must be given to the potential for hazard when dealing with these chemicals.



- Do not use the instrument in close proximity to strong electromagnetic radiation, as these may interfere with the proper operation. The electromagnetic environment should be evaluated prior to operation of the device.
- Do not introduce any source of ignition into, or near, the instrument once it has been loaded with reagents.
- Do not remove any panels or access covers, unless specifically instructed to do so. The instrument does not have any user serviceable parts. Potentially lethal voltages are present inside the instrument.
- The instrument must be properly connected to a good earth (ground) via the Mains input supply and positioned such that it is possible to interrupt the Mains supply at the source by removing the plug from the socket.
- Use only factory approved accessories or replacement parts within the instrument.
- Only use reagents recommended in the operator guide.
- Position the instrument such that it is possible to interrupt the Mains supply at the source by removing the plug from the socket.
- If the equipment is used in a manner not specified by Thermo Fisher Scientific, the protection offered by the equipment may be impaired.

Environment

This instrument is required to comply with the European Union's Waste Electrical and Electronic Equipment (WEEE) Directive 2002/96/EC. It is marked with the following symbol:



Thermo Fisher Scientific has contracts with one or more recycling / disposal companies in each EU Member State, and this product and packaging should be disposed of or recycled through them. For further information contact your Thermo Fisher Scientific service representative.

Warranty Statement

Thermo Fisher Scientific is proud of their quality, reliability and of our after-sales service. We continuously strive to improve our service to our customers.

Please ask your distributor or Thermo Fisher Scientific representative about service contracts which can help maintain your instrument in an optimal operating condition.

Warranty provisions necessarily vary to comply with differences in national and regional legislation. Specific details can be found in the delivery documentation or from your dealer or representative.

Please note that your warranty may be invalidated if:

- This instrument is modified in any way, or not used as intended by Thermo Fisher Scientific.
- Accessories and reagents which have not been approved by Thermo Fisher Scientific are used.
- The instrument is not operated or maintained in accordance with instructions.

How To Use This Guide

Introduction

The Thermo Scientific PrintMate AS is a high-speed cassette labelling instrument designed for use in laboratories by operators familiar with cassette labelling techniques and laboratory equipment.

Before operating PrintMate AS , users should have read and understood the [Safety Information](#) as well as the LabWriter Operator Guide (A82810105).

Chapter 1 - Introduction to PrintMate AS

This chapter gives a tour of the instrument and its features. It describes the different parts of the instrument and gives general information with regards to interfacing with the PrintMate AS.

Chapter 2 - Installation and Setup

This chapter is a step-by-step guide to installing and setting up PrintMate AS and its accessories.

Chapter 3 - Basic Operation

This chapter explains the basic operating techniques required to perform routine tasks and use PrintMate AS on a day-to-day basis.

Chapter 4 - Troubleshooting

This chapter is intended to help operators identify and cure common faults.

Chapter 5 - Cleaning and Maintenance

This chapter lists the cleaning schedules which should be followed to ensure safe and reliable operation.

The PrintMate AS Product Range

The PrintMate AS product range consists of 3 different models with varying cassette capacity.

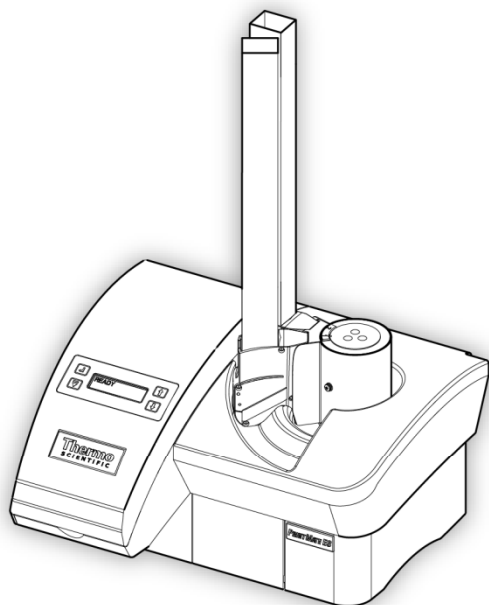

Thermo Scientific PrintMate AS 150

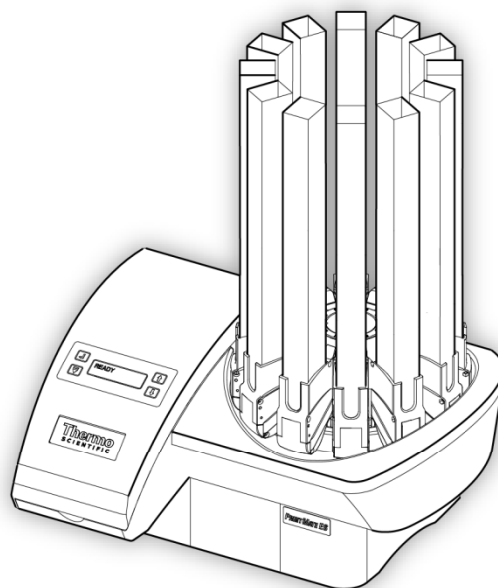

Thermo Scientific PrintMate AS 900

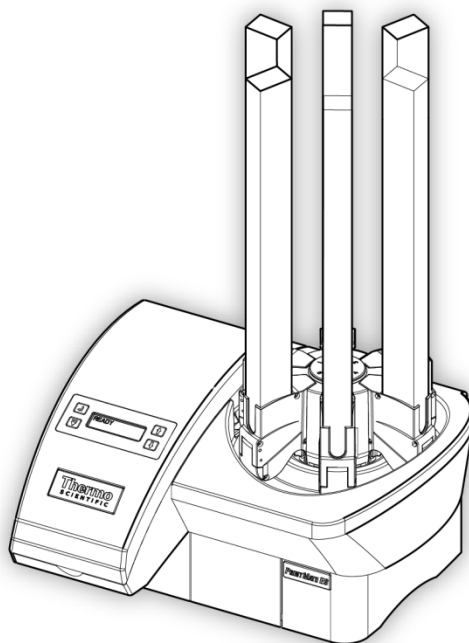

Thermo Scientific PrintMate AS 450

The methods of operation for each of these instruments are identical.

Chapter 1 - Introducing PrintMate AS

[Identification of Parts](#)

[System Interaction](#)

[System Specification](#)

Identification of Parts

The following diagrams identify the different components of PrintMate AS.

PrintMate AS with doors closed

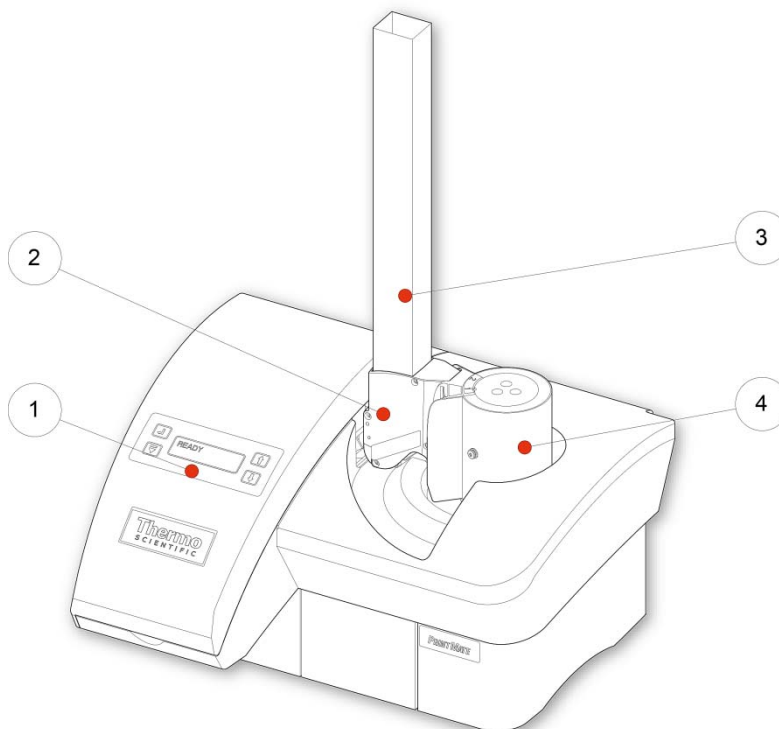

PrintMate AS with doors open

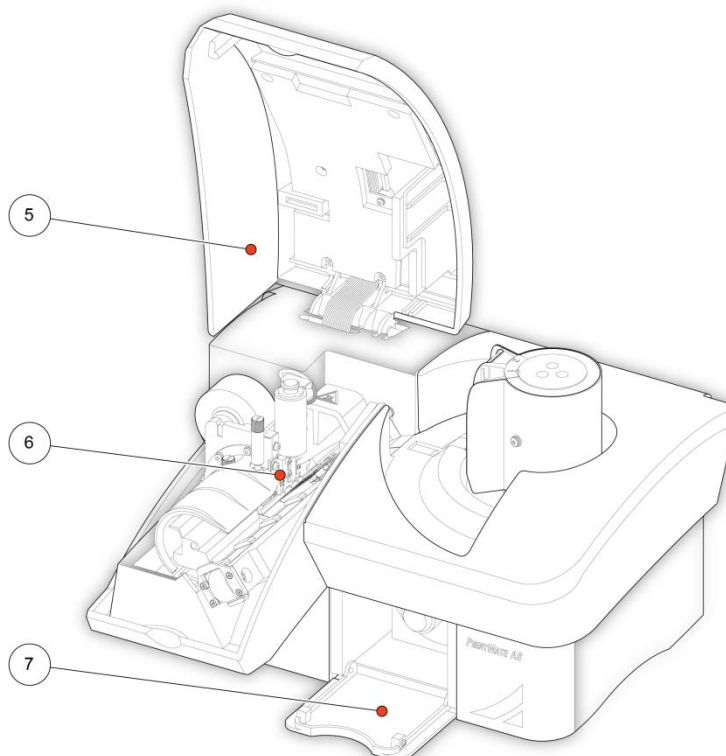

PrintMate AS external connections

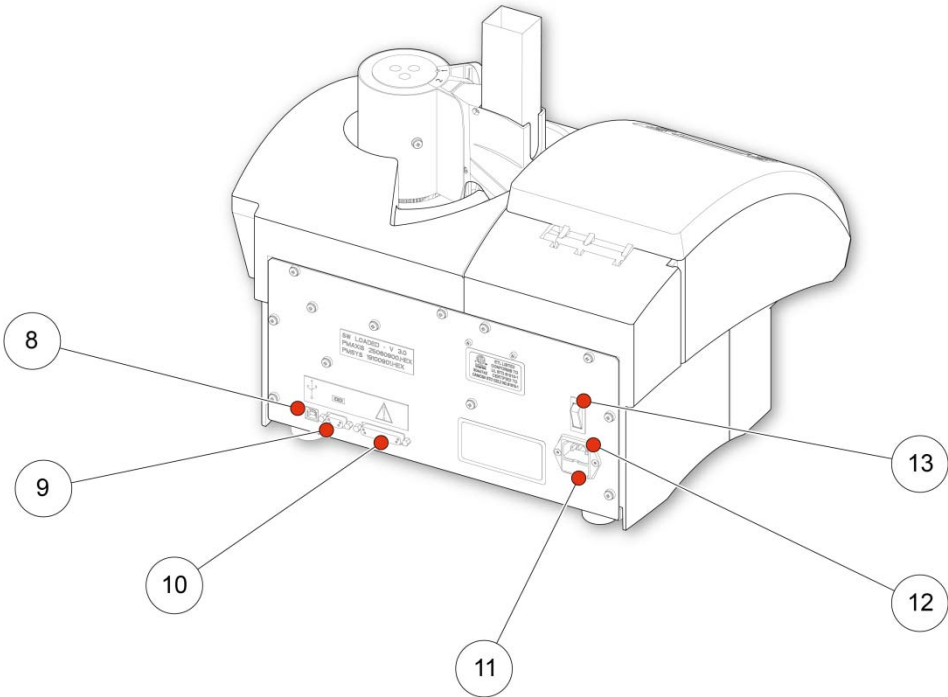

PrintMate AS Print Head

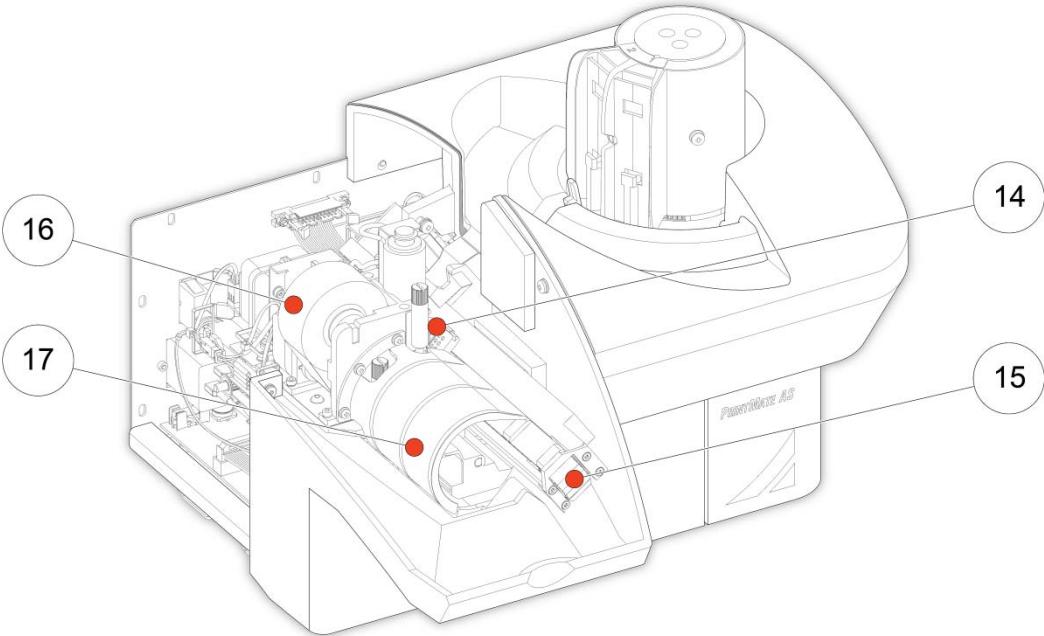

List of parts

Item	Description
1	Touch Panel and Display
2	Cassette Hopper
3	Cassette Tube
4	Carousel
5	Print Door
6	Print Head
7	Waste Spool Access
8	USB Connection
9	9-Pin Serial Port
10	Collection System Connector
11	Fuse
12	Power Connector
13	Power Switch
14	Cassette Clamp
15	Conveyor Belt
16	Hot Foil Tape
17	Output Drum

System Interaction

The two methods of interacting with PrintMate AS are:

- Using the LabWriter Application provided with the instrument as explained in the LabWriter Application Operator Guide (A82810105).
- Using the Touch Panel on the instrument - *see Chapter 2 - [Using the Touch Panel](#).*

System Specification

Mechanical Specification

Height	810 mm (with cassette tubes) / 290 mm (without cassette tubes)
Width	435 mm
Depth	380 mm
Weight	17 kg (with cassette tubes)

Electrical Specification

Voltage	100-120 V~ / 220-240 V~
Frequency	50 / 60 Hz
Power	220VA (750 BTU/h)
Earth Leakage	(Up to 220 V) (<3500 μ A, > 220 V)
Fuses	T2A H250V (2 off)

Environmental Specification

Warning - For indoor use only	
Temperature (Operating Limits)	+5°C to +40°C (+41°F to +104°F)
Temperature (Recommended Operation)	+15°C to +30°C (+59°F to +86°F) Note Performance may deteriorate when operated outside of this range
Temperature (Storage)	-25°C to +55°C (-13°F to +131°F) / +70°C (+158°F) for short exposure
Relative Humidity	Max. 80% RH up to 31°C, decreasing linearly to 50% RH at 40°C
Altitude	Up to 2,000 m (6,500 ft)
Pollution Degree	2
Over Voltage Category	II

Chapter 2 - Installation and Setup

Installation and Setup

Setting up PrintMate AS

Connecting the Output Chutes

Changing the COM Port Settings

Setting Up PrintMate AS

Setting Up PrintMate AS:

- Unpacking
- Locating the PrintMate AS
- Setting up the Electrical Connections

Unpacking

To unpack PrintMate AS:

- Remove uppermost foam piece.

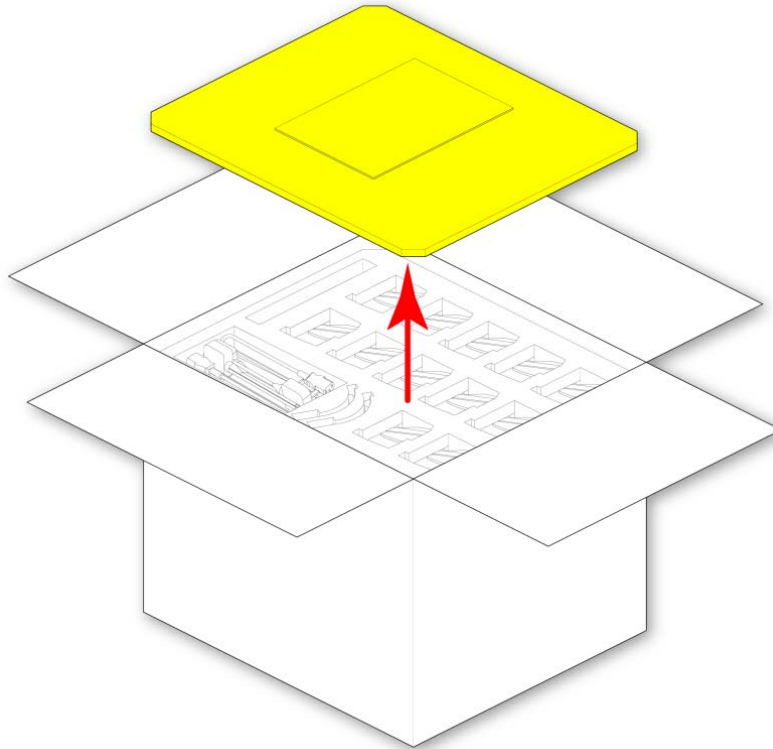

- Remove the Leads, Hoppers and Output Chute pieces.

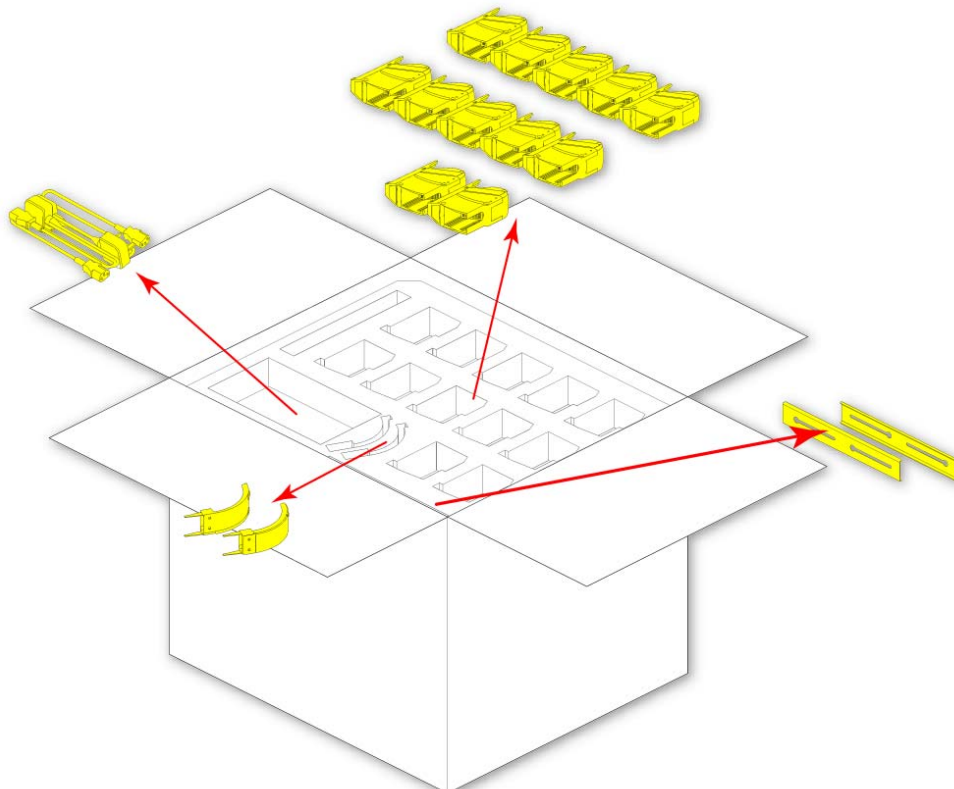

- Remove the foam tray.

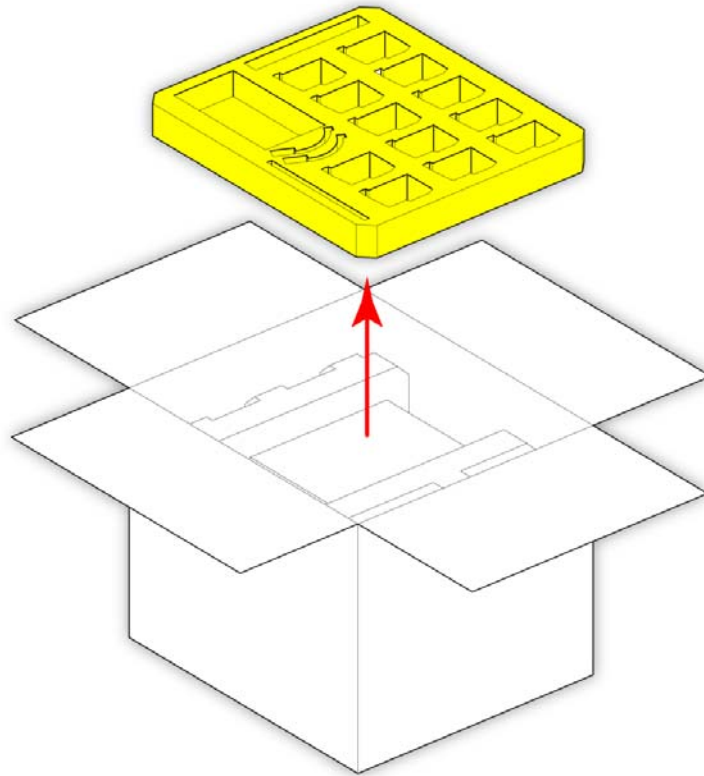

- Remove the foam base mat and the operator pack.

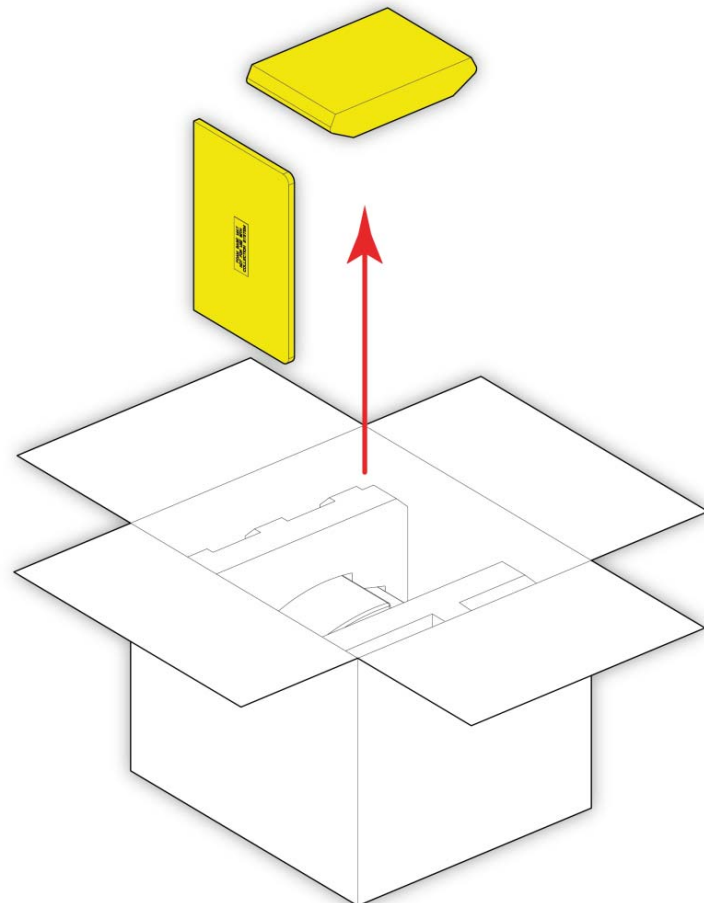

- Lift out the PrintMate AS and the surrounding foam pieces and place onto a suitable level surface.

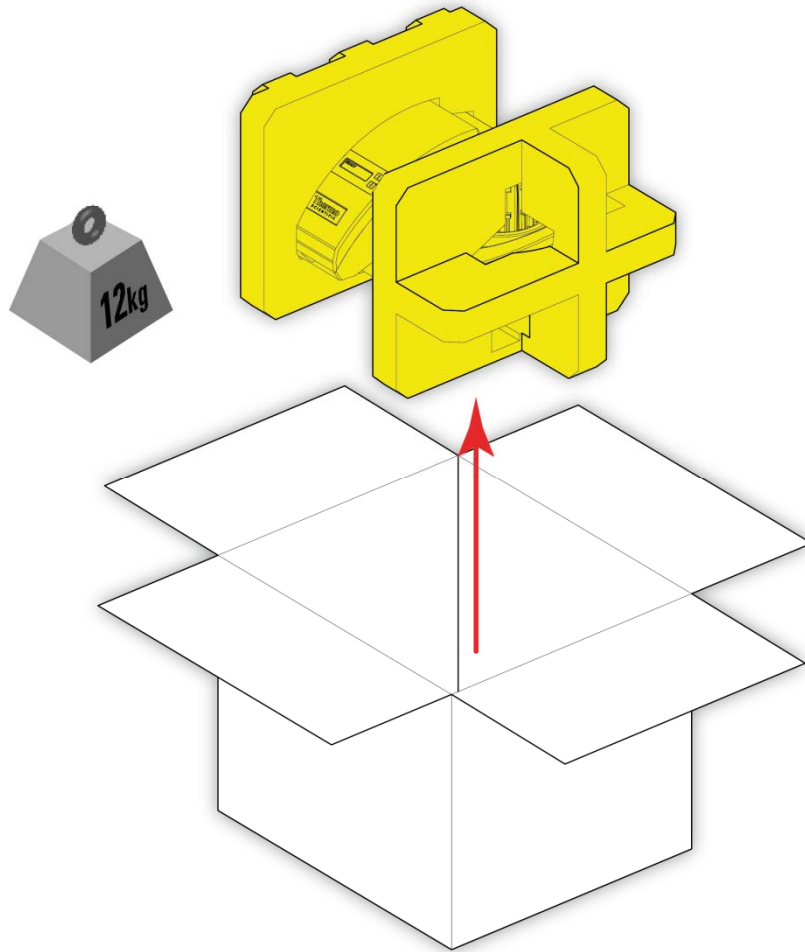

PrintMate AS weighs approximately 12 kg (26 lbs), and help may be required to ensure safe lifting.

- Taking care not to let the unit fall, remove the remaining foam pieces.

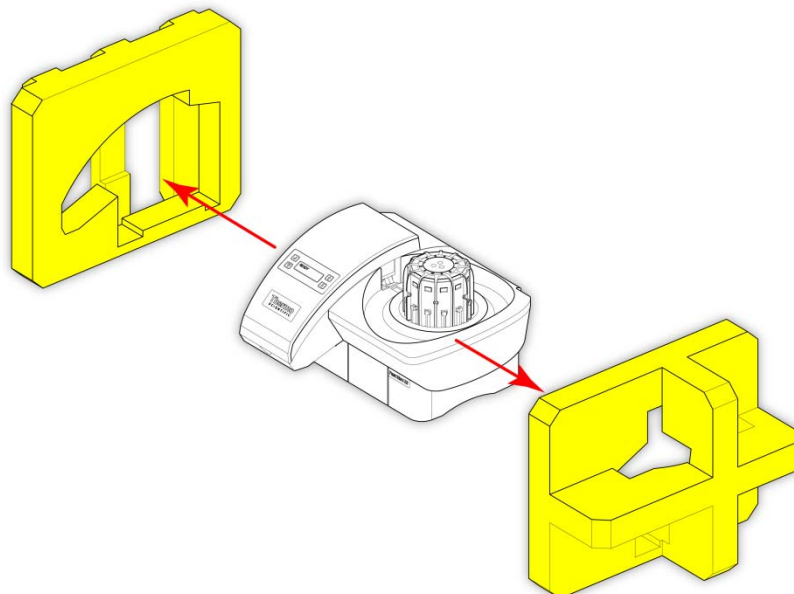

- Open the Print Door and unscrew the transit lock lever from the locked position and return to the stored position.

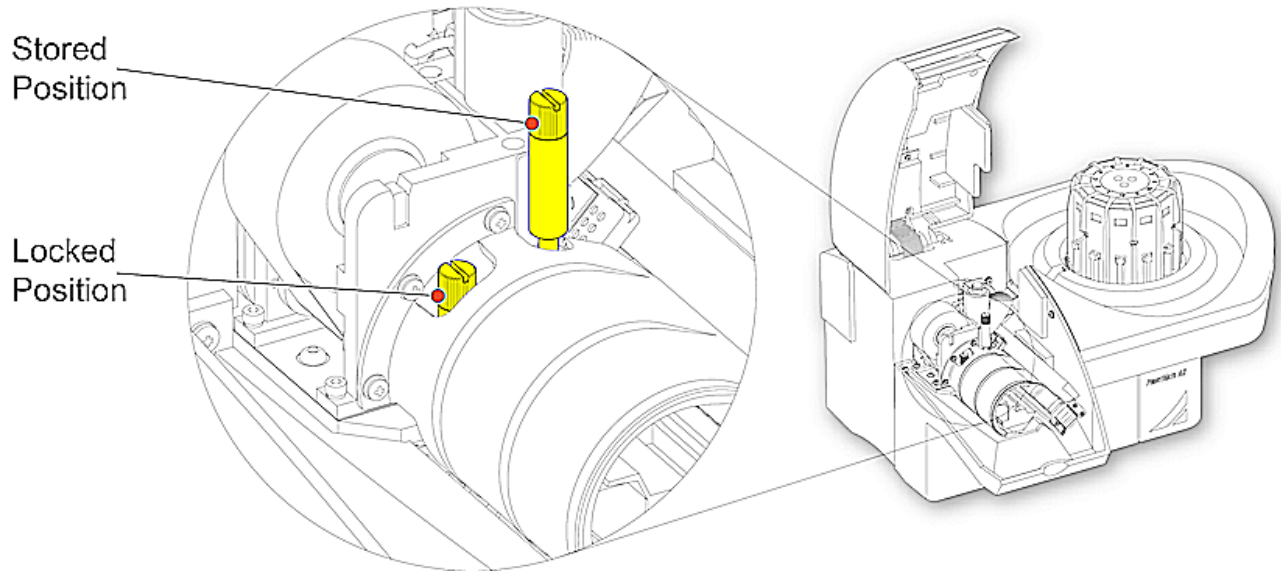

Locating PrintMate AS



PrintMate AS must be located on a level surface capable of supporting the weight of the instrument and the PC.

PrintMate should be positioned so that it has a minimum of 100 mm (4 in) gap on all sides, as well as sufficient space above it to allow Hoppers and Cassette Tubes to be connected and removed.

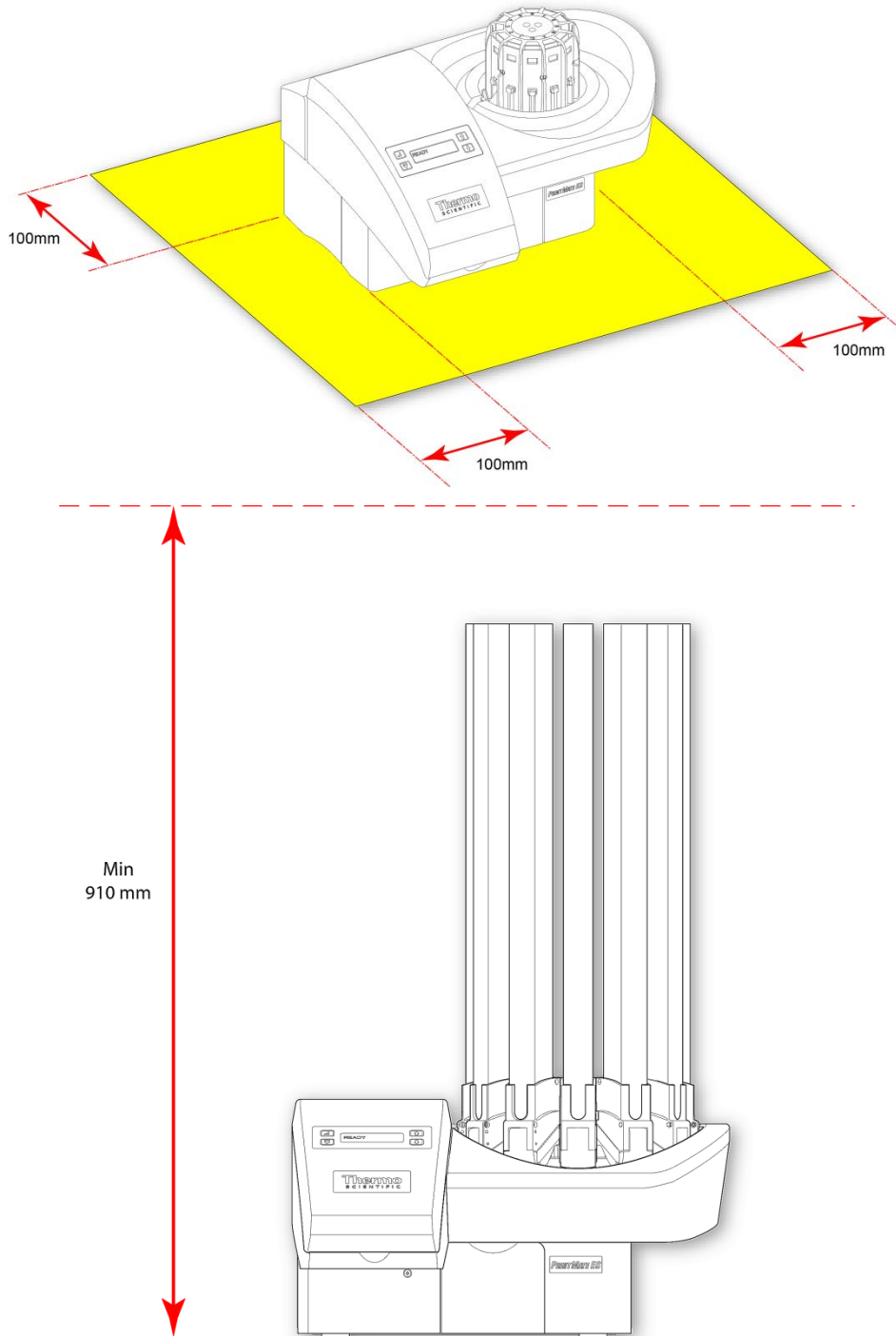

PrintMate AS should be located close enough to the connected PC to ensure that connection wires are not strained.

Electrical Connections and Start-Up Procedure

Note

The following instructions assume that the LabWriter Application has been pre-installed. If this is not the case refer to the LabWriter Operator Guide (A82810105) Chapter 1 - Installing the Software.

The PC and PrintMate should be connected as follows:

- Set up the PC as described in the manufacturers' instructions.
- Position the instrument such that it is possible to interrupt the Mains supply at the source by removing the plug from the socket.
- Ensure the Power Switch on PrintMate is set to the Off (O) position.
- Connect the Power Lead to the Power Connector and then plug it in to a suitably rated Mains Power Supply.
- The length of the Mains Cord should not be greater than 3m.
- This instrument is supplied with power cables suitable for the UK, the USA, France and Germany. If an alternative plug is required, a technically-competent person must remove the moulded plug and replace it with a suitably rated, fused plug.

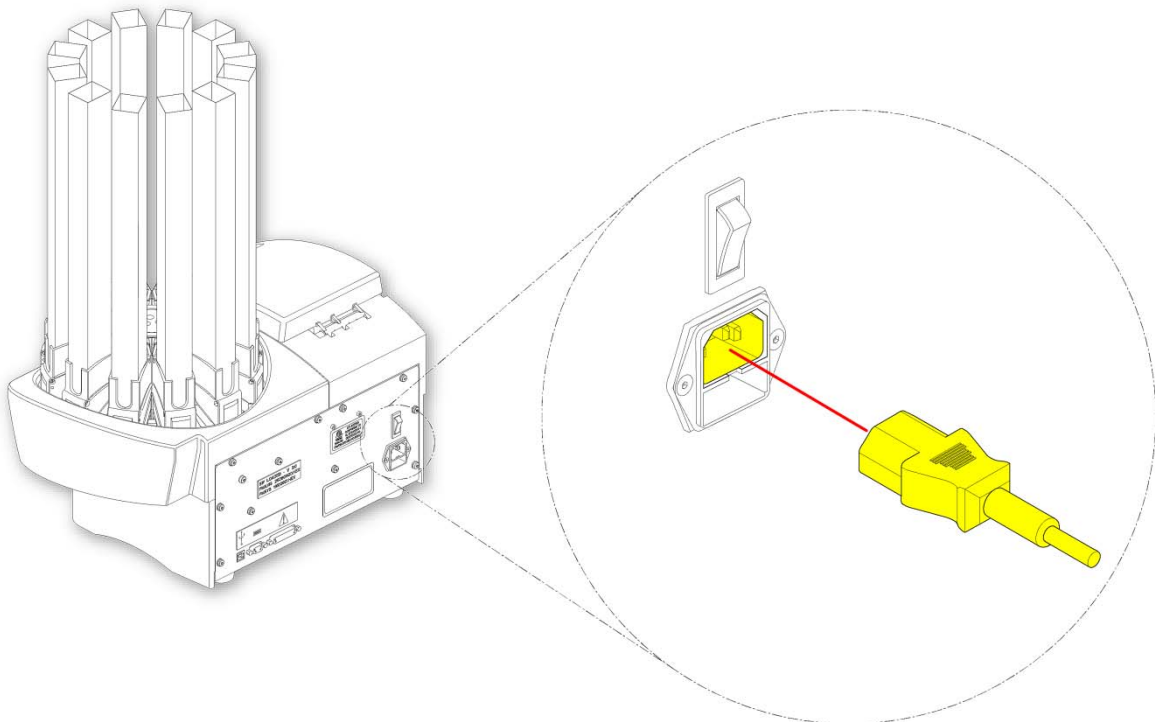

- Power up the PC so that the Windows Desktop is shown.
- Ensure the LabWriter Application is correctly installed onto the PC.



Do not run the LabWriter Application yet.

- Turn on PrintMate and wait until the Touch Panel Display reads **PrintMate Ready**.
- Connect the USB (Type A) Connector to the PC.

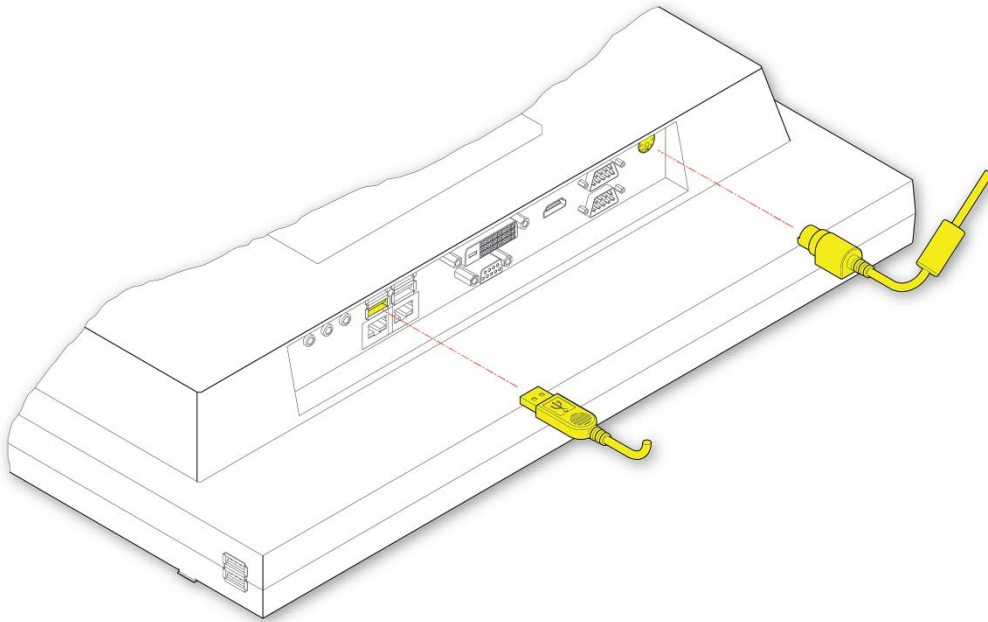

- Connect the USB (Type B) Connector to the back of PrintMate.

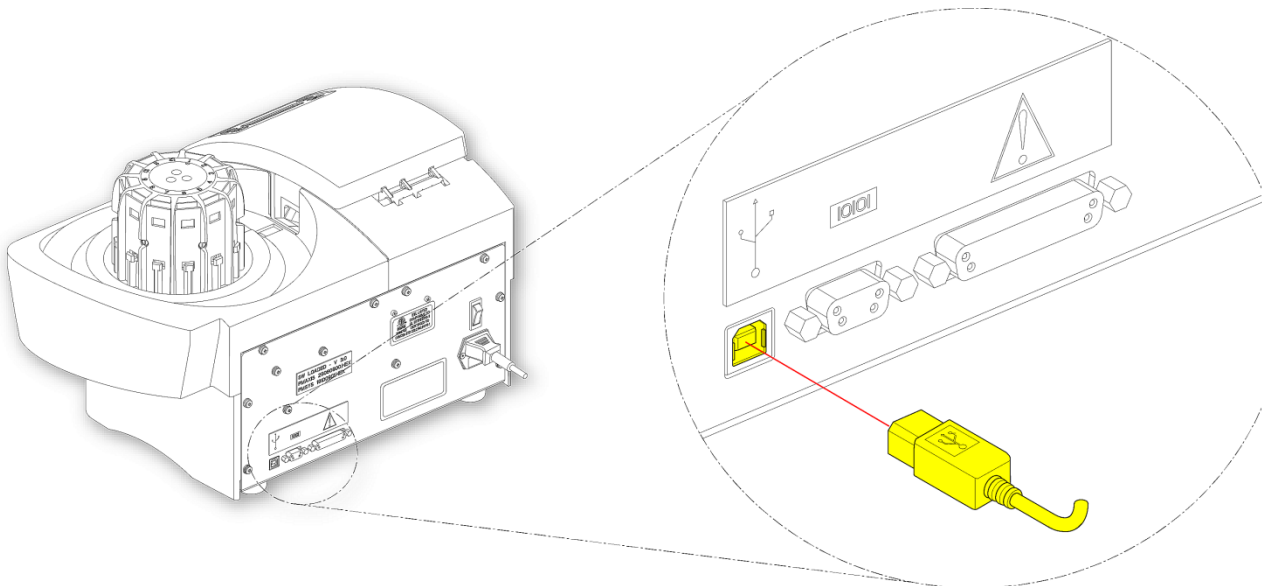

- The PC should emit a chime and indicate that it has found a USB device.
- The LabWriter Application should now be able to be run and setup in accordance with the instructions given in the LabWriter Application Operator Guide (A82810105).
- PrintMate AS operates at a faster Baud Rate than PrintMate, refer to [Changing the COM Port Settings section](#).

Connecting the Output Chutes

The PrintMate AS Chutes included with PrintMate AS fit on either (or both) of the two inner output positions (Outputs 1 and 2).

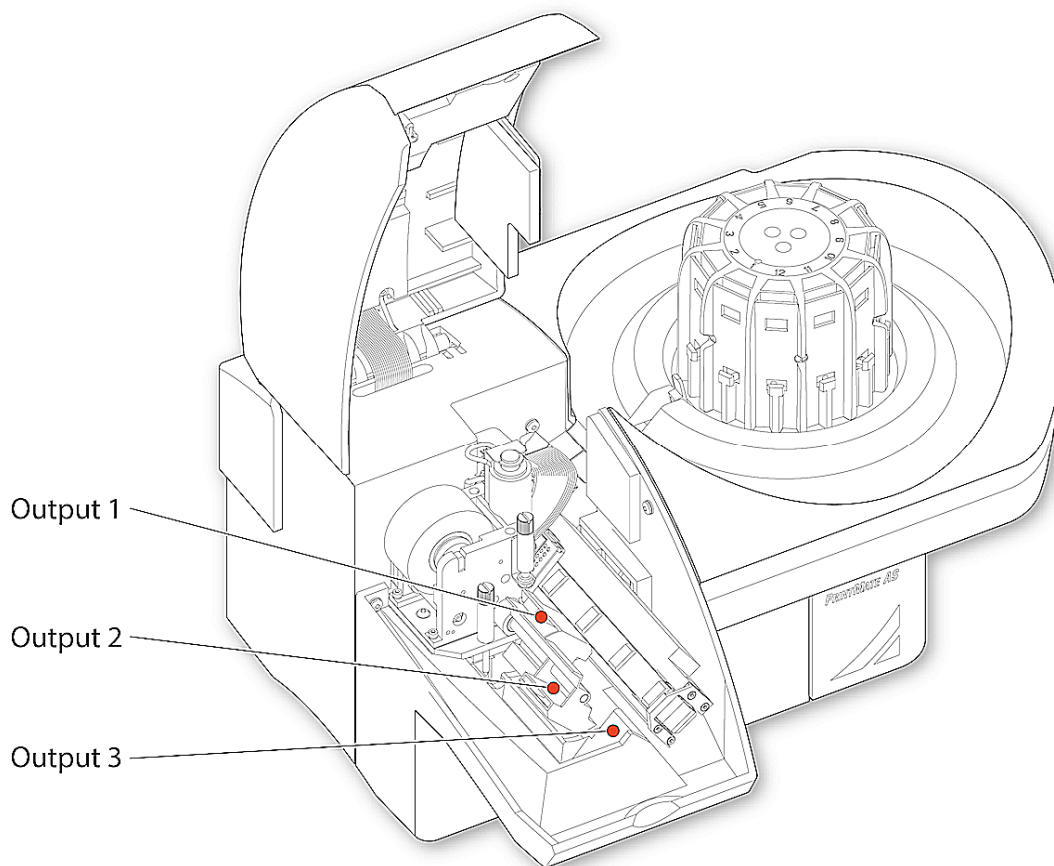

They can be connected so that they dispense either to the left or the right of the instrument as required.

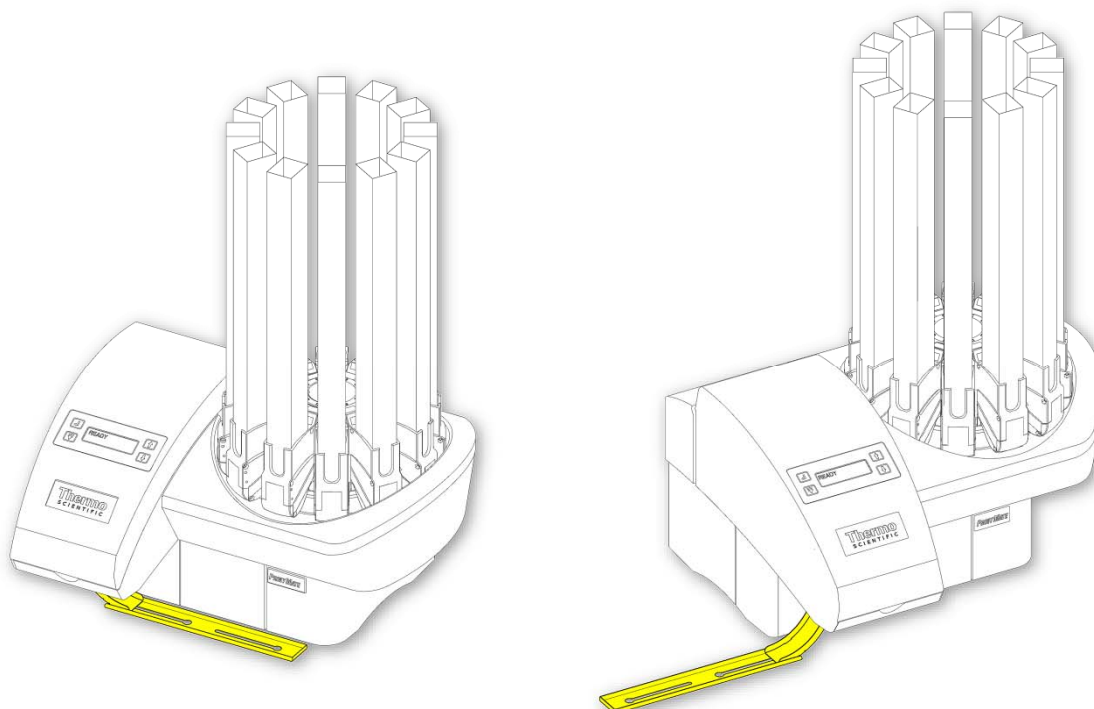

The Output Chutes are assembled and connected as follows:

- Fit the Location Button on the Upper Chute into the open end of one of the Keyhole Slots in the Lower Chute.

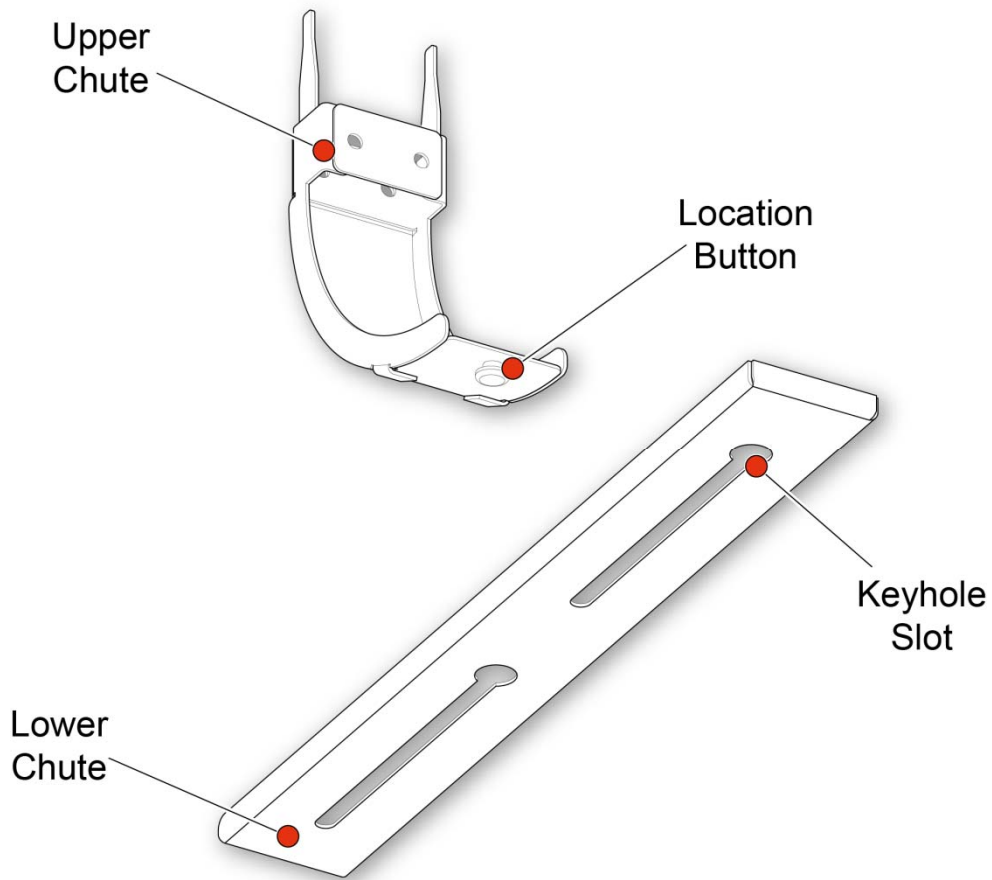

- Slide the Upper Chute along the Lower Chute so that the two pieces are securely located together.

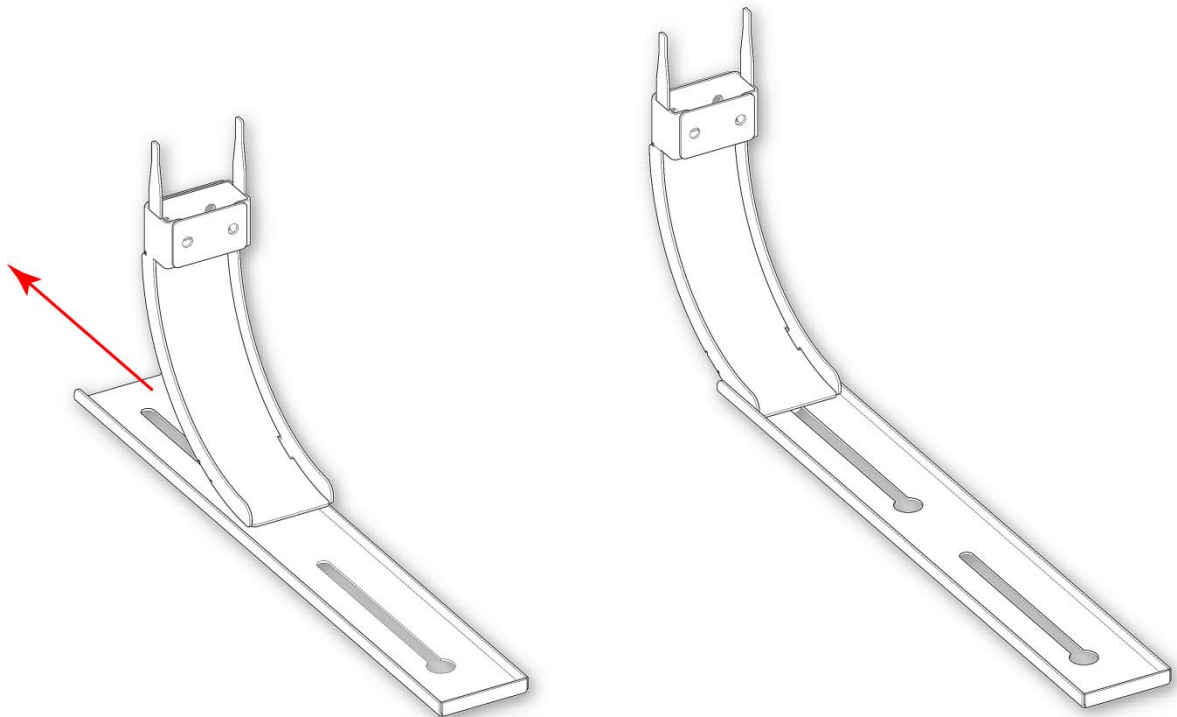

- The assembled Output Chute(s) should be fitted into the underside of PrintMate AS so that the Ball Spring Plunger locates fully into the Location Hole.

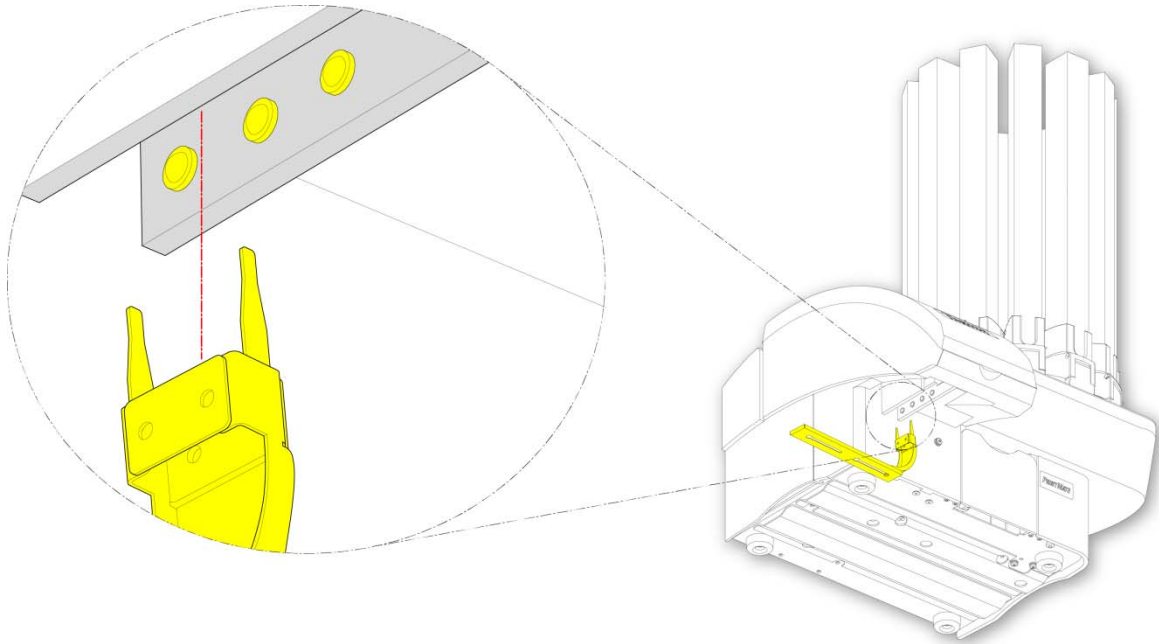

Failure to ensure correct fitting of the output chute may cause jams.

Changing the COM Port Settings

During the LabWriter Installation process (see LabWriter Operator Guide, Chapter 1 - Installing the LabWriter Application) the software should automatically detect the PrintMate AS and determine the correct COM Port Setting.

However, if LabWriter does not detect the PrintMate AS instrument the COM Port can be set manually.

The procedure for this is as follows:

- Ensure PrintMate AS is connected to the PC, is switched on and the Touch Panel Display shows **PrintMate AS Ready**.
- Open the Windows Control Panel.

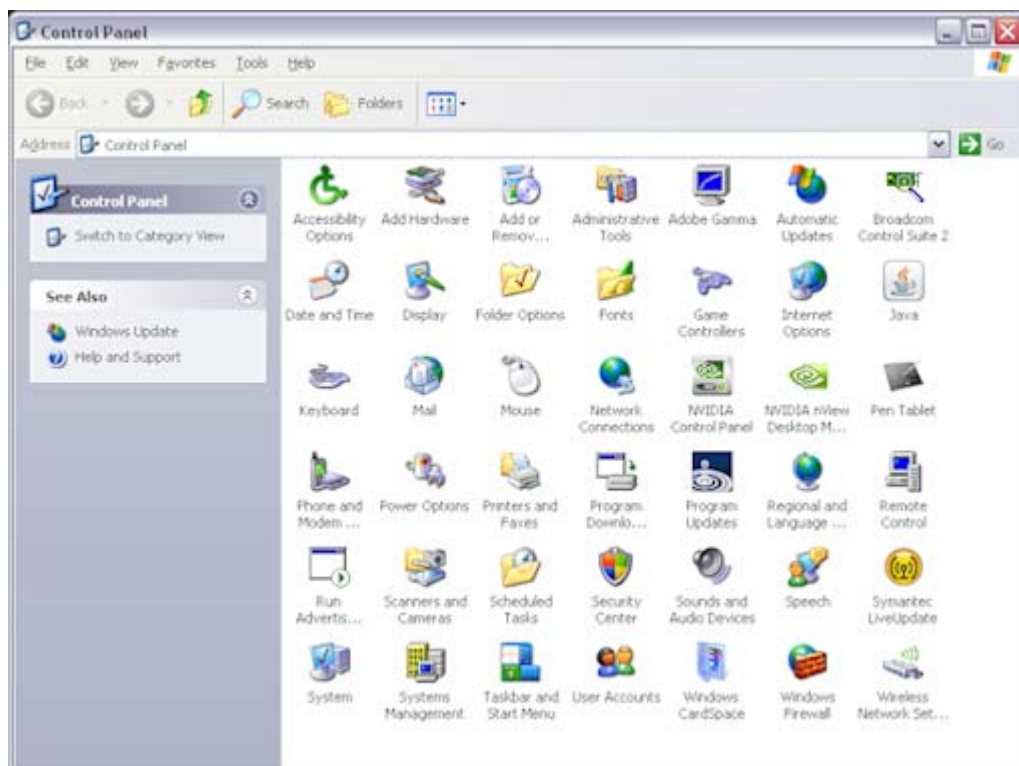

- Double-click on the System icon to display the System Properties window.



System

- In the System Properties window click on Device Manager.

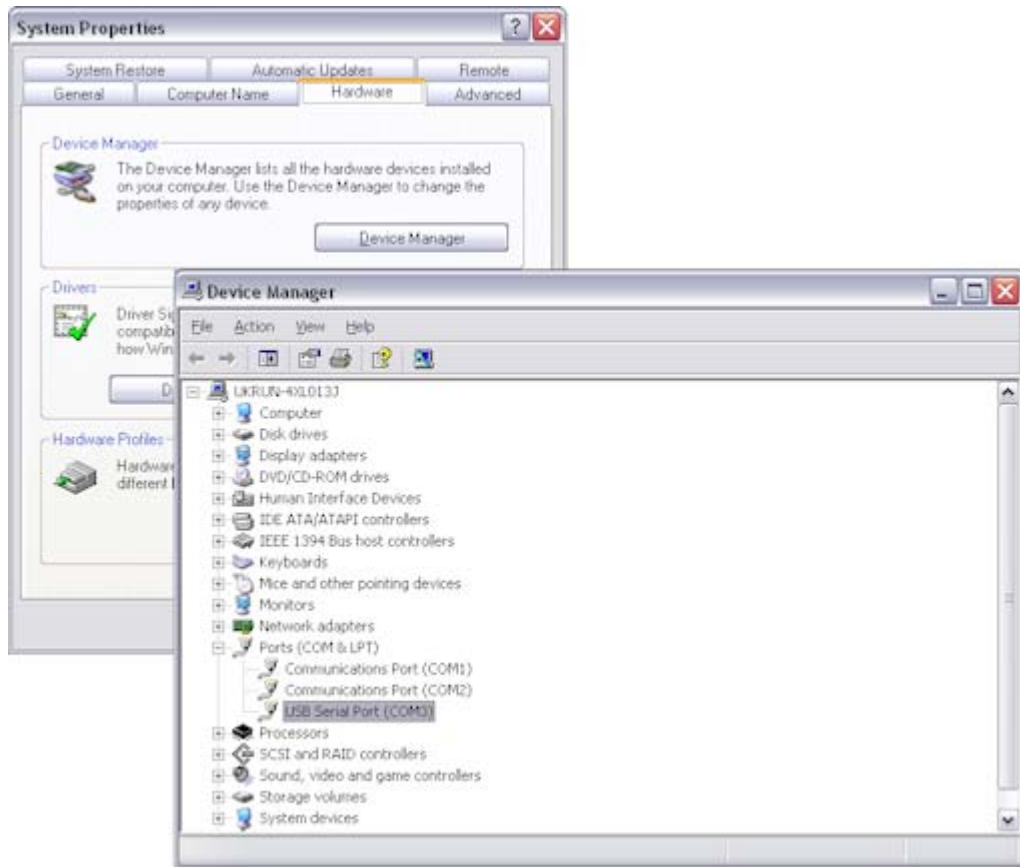

- The PrintMate AS connection will be listed as a **USB Serial Port** with a COM number after it.
- Note the COM Port number that the PrintMate AS is using.
- Run the LabWriter Application and enter the Admin Area (see LabWriter Operator Guide, Chapter 2 - Admin Logon).
- Click on the Devices Tab.
- Expand the **PrintMate** device and click on the PrintMate Sub-Level Device to display the Device Properties List.

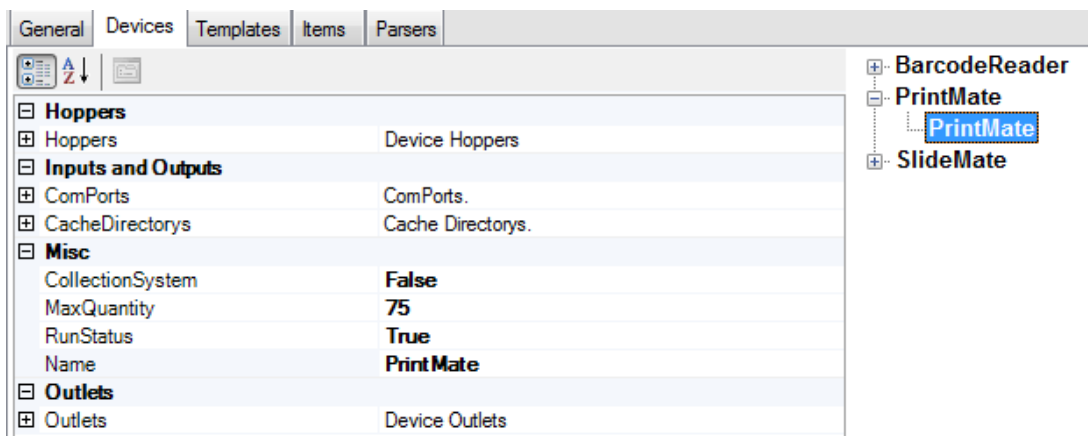

- Expand the COM Port property and select the appropriate COM number from the drop-down list in the field next to Port.

Inputs and Outputs	
ComPorts	ComPorts.
	ComPort
Direction	Out
Port	COM3
Baud	COM2
DataBits	COM1
Parity	None

- Set the Baud Rate to 57600 for PrintMate AS and to 19200 for PrintMate.

Inputs and Outputs	
ComPorts	ComPorts.
	ComPort
Direction	Out
Port	COM6
Baud	57600
DataBits	8
Parity	None

- Click on the Search icon at the top of the screen.



- After a pause LabWriter should display the following window to show that it has found the PrintMate AS.

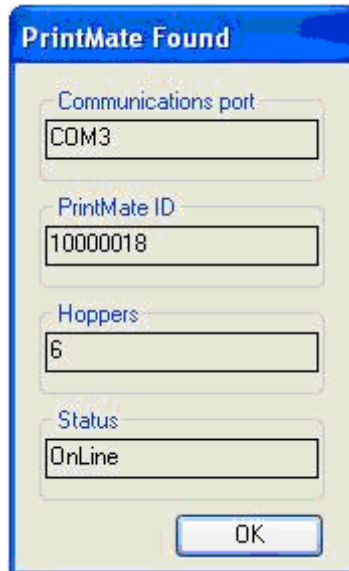

- Click OK and then the Save and LogOff button to exit the Admin Area.

Chapter 3 - Basic Operation

Basic Operation

Loading Procedure:

- Loading Cassette Tubes with Hopper Removed
- Loading Cassette Tubes with Hopper In-Situ
- Loading Single Cassettes Into Hopper
- Loading Hoppers Onto the Carousel

Changing the Foil Tape:

- Removing the Used Foil Tape
- Fitting the Foil Tape Roll

Using the Touch Panel

Hopper Types

Two colour coded types are available for PrintMate AS

- For standard approved cassettes please use A79510024 (coloured black)

There are two methods of loading Cassette Tubes into Hoppers.

Loading can be carried out with the Hopper removed from the Carousel or in-situ.

Loading Cassette Tubes with Hopper Removed

To load Cassette Tubes containing up to 75 Cassettes into a Hopper:

- Remove an empty Hopper from the Carousel.

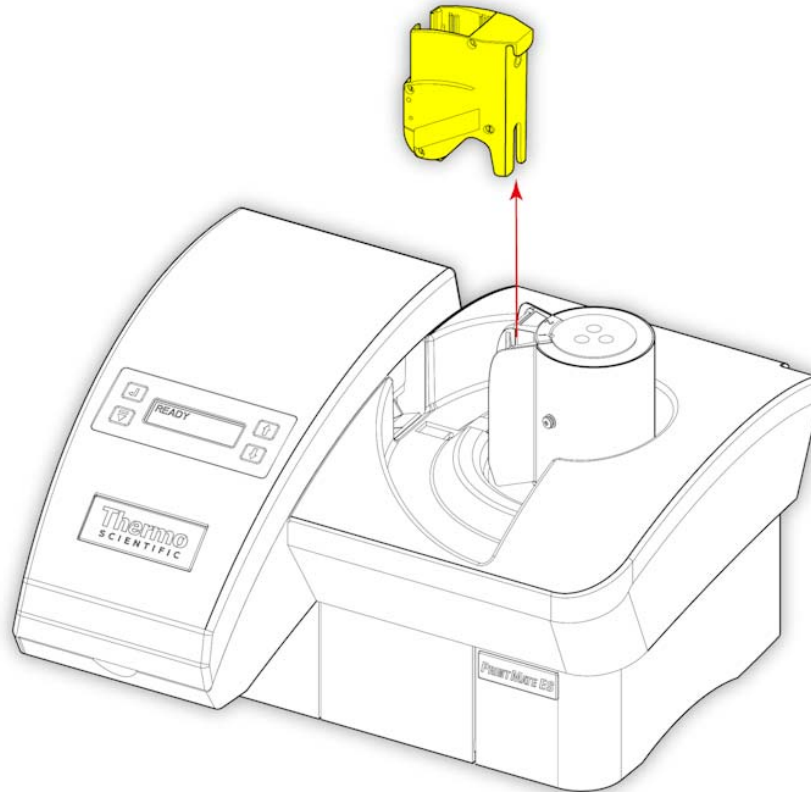

- Place the Hopper on a flat surface so that it is stood upright as shown.

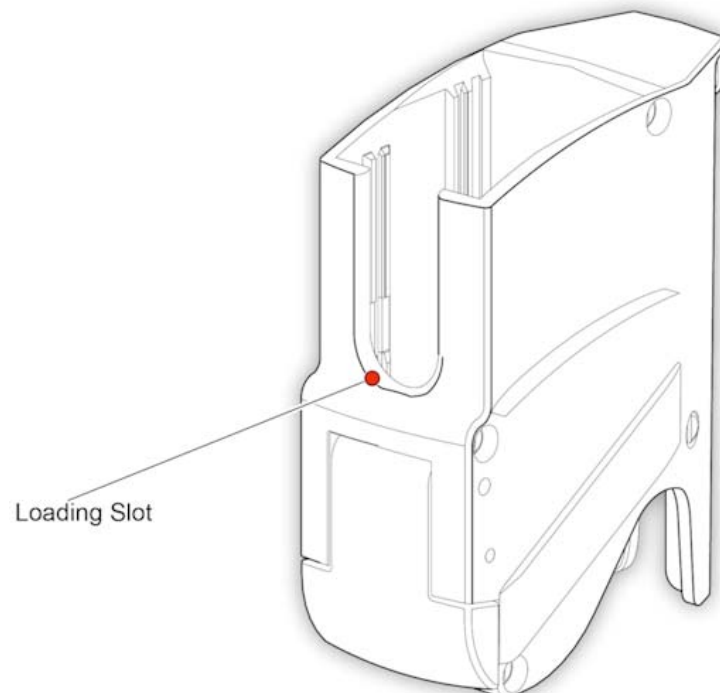

- Unpack a Tube of Cassettes and remove the End-Cap as shown.

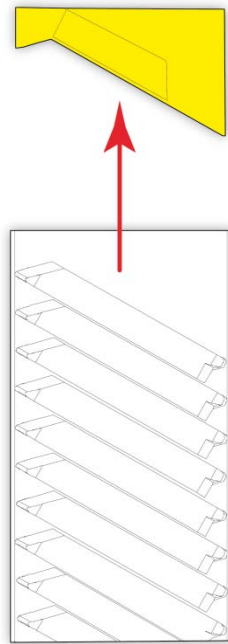

Note

Ensure the Cassette Tube is oriented as shown to avoid the Cassettes spilling out of the Tube.

- Use a finger to hold the Cassettes in the Tube and then turn it upside down so that the open end of the Tube is at the bottom.
- Lower the Tube into the open top of the Hopper, being sure to keep a finger on the bottom for as long as possible; there is a Loading Slot provided for this purpose.

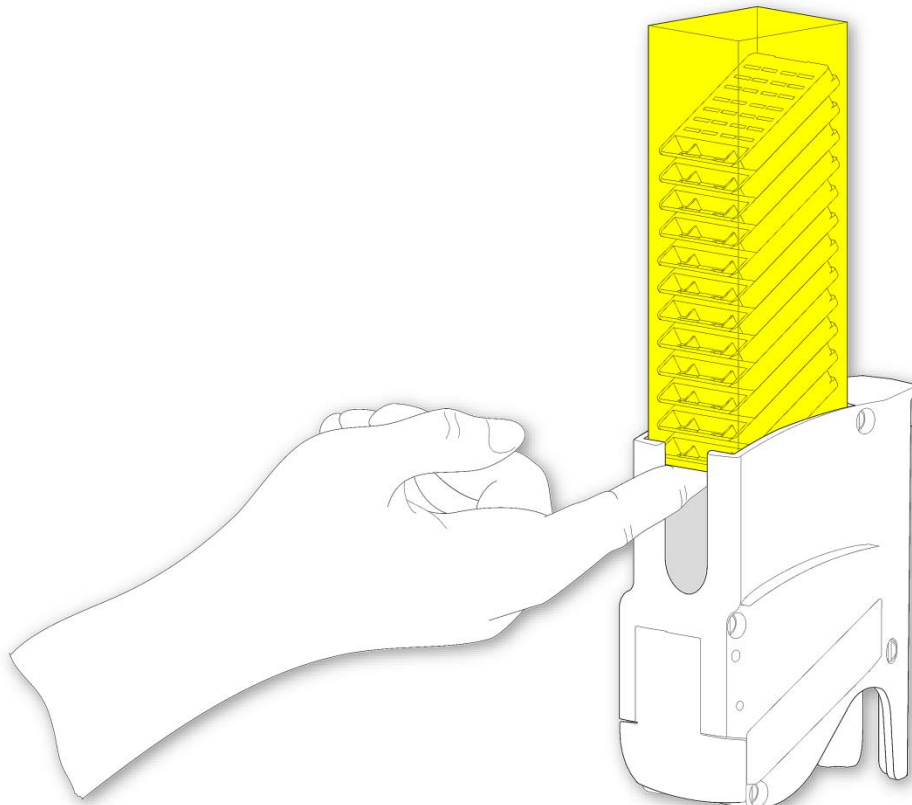

- Remove finger from the Loading Slot and allow the Cassettes to fall into position as shown.

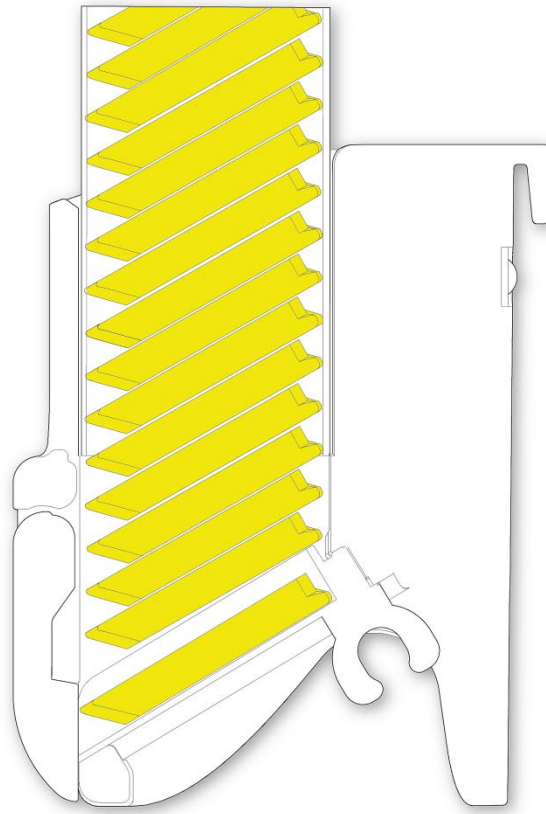

- The Cassette Tube should sit on a step about half-way down the Hopper as shown.



Failure to ensure Cassettes are properly loaded can cause the hopper to jam.



Ensure that the end of the Cassette Tube is not damaged or deformed as this may cause jams.

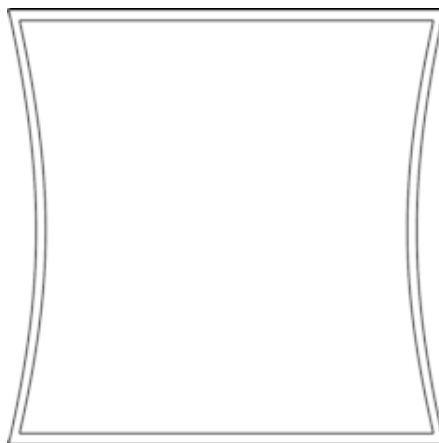

Note

When loading Cassette Tubes into Hoppers that are not attached to the Carousel, it is possible to fit the Hopper with the Tube upside down to avoid the risk of spilling the Cassettes out of the Tube.

Loading Cassette Tubes with Hopper In-Situ

To load Cassettes Tubes containing up to 75 Cassettes into a Hopper:

- Use the Control Panel to rotate the Carousel so that an empty Hopper is at the front of the instrument.

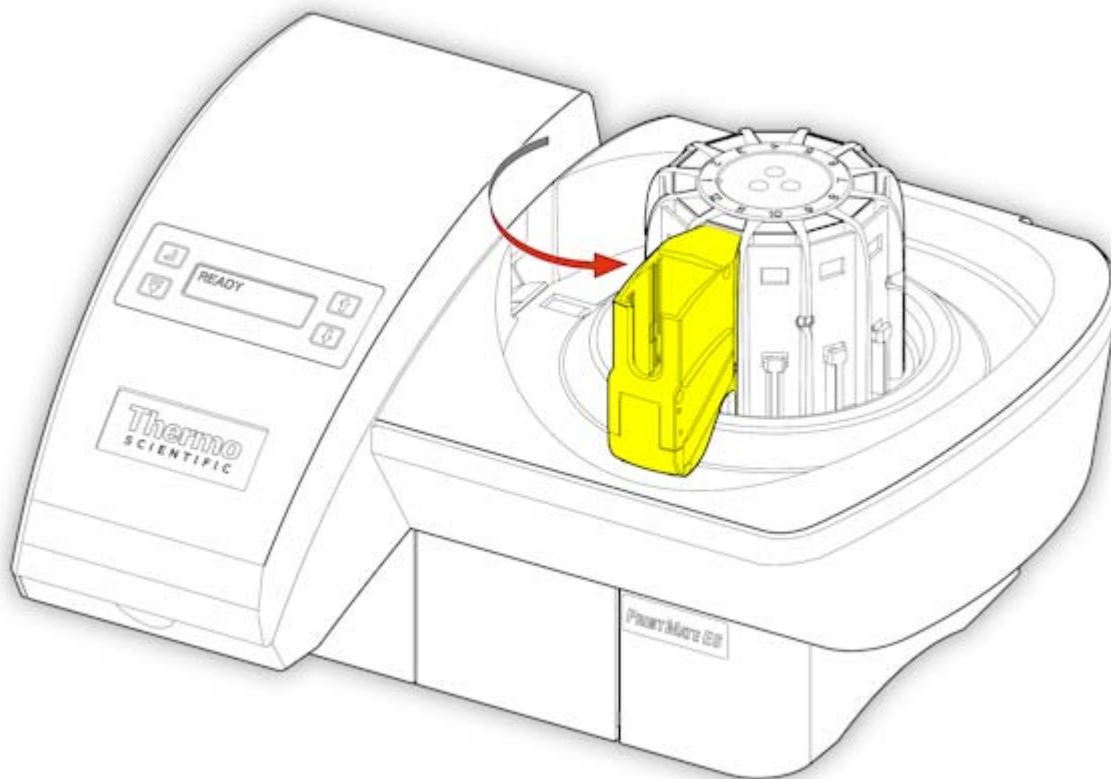

- Unpack a Tube of Cassettes and remove the End-Cap as shown.

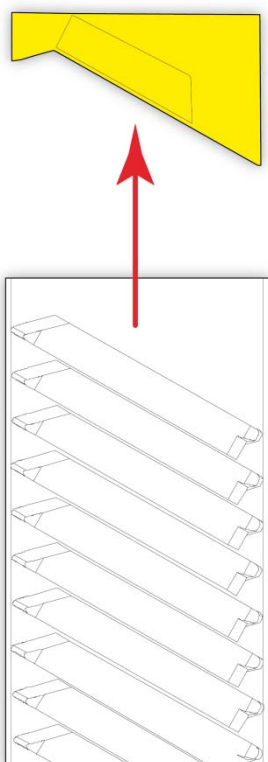

Note

Ensure the Cassette Tube is oriented as shown to avoid the Cassettes spilling out of the Tube.

- Use a finger to hold the Cassettes in the Cassette Tube and then turn it upside down so that the open end of the Cassette Tube is at the bottom.
- Lower the Cassette Tube into the open top of the Hopper, being sure to keep a finger on the bottom for as long as possible; there is a Loading Slot provided for this purpose.

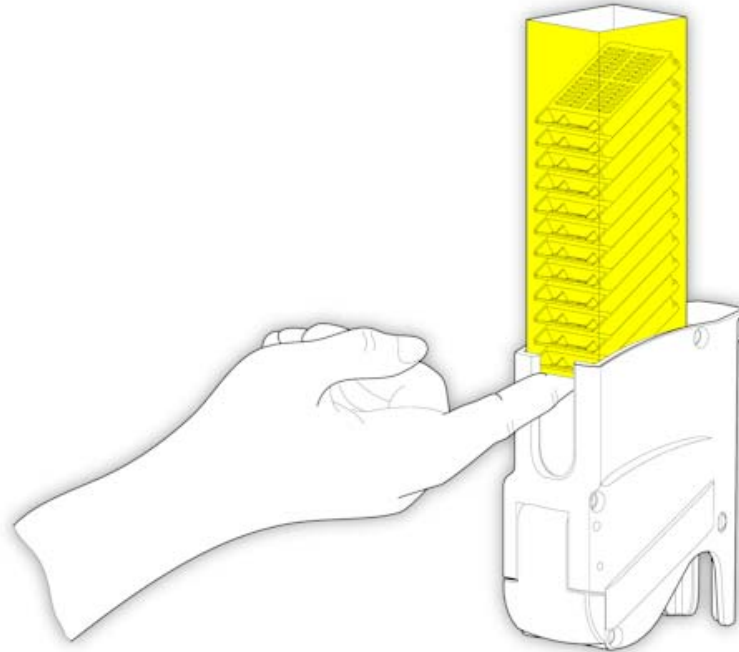

- Remove finger from the Loading Slot and allow the Cassettes to fall into position as shown.

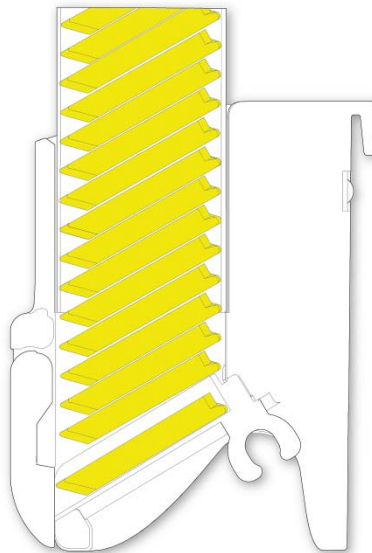

- The Cassette Tube should sit on a step about half-way down the Hopper.



Failure to ensure cassettes are properly loaded can cause the hopper to jam.



Ensure that the end of the cassette tube is not damaged or deformed as this may cause jams.

Loading Single Cassettes Into Hoppers

To load individual Cassettes into Hoppers:

- Without removing the Hopper from the Carousel, drop a Cassette into the open top of the Hopper.

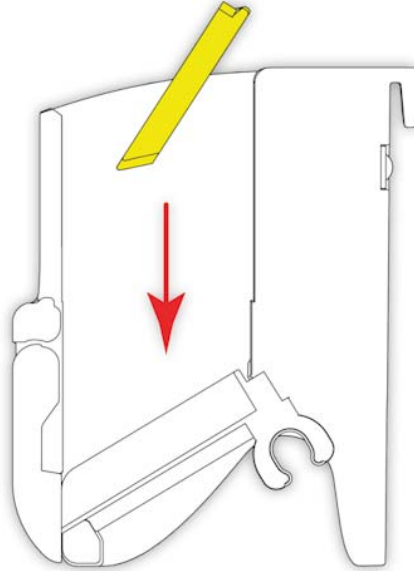

Note

Ensure the Cassette is oriented as shown.

Note

If the cassettes have lids, ensure they are fully closed before use.

- Ensure the Cassette sits as shown.

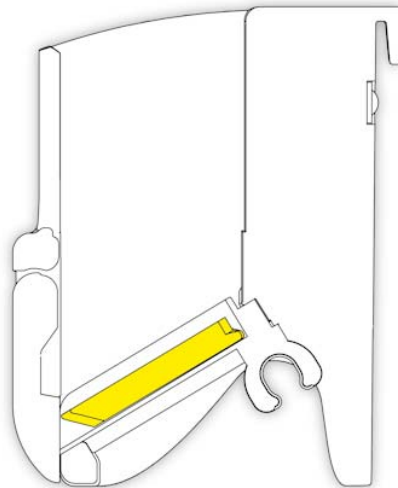

Failure to ensure cassette is properly loaded can cause the hopper to jam.



Do not mix cassette types when loading individual cassettes as this may cause the instrument to jam.

Loading Hoppers Onto the Carousel

The Hoppers are loaded onto the Carousel as follows:

- Identify the features on the Hopper and Carousel shown below.

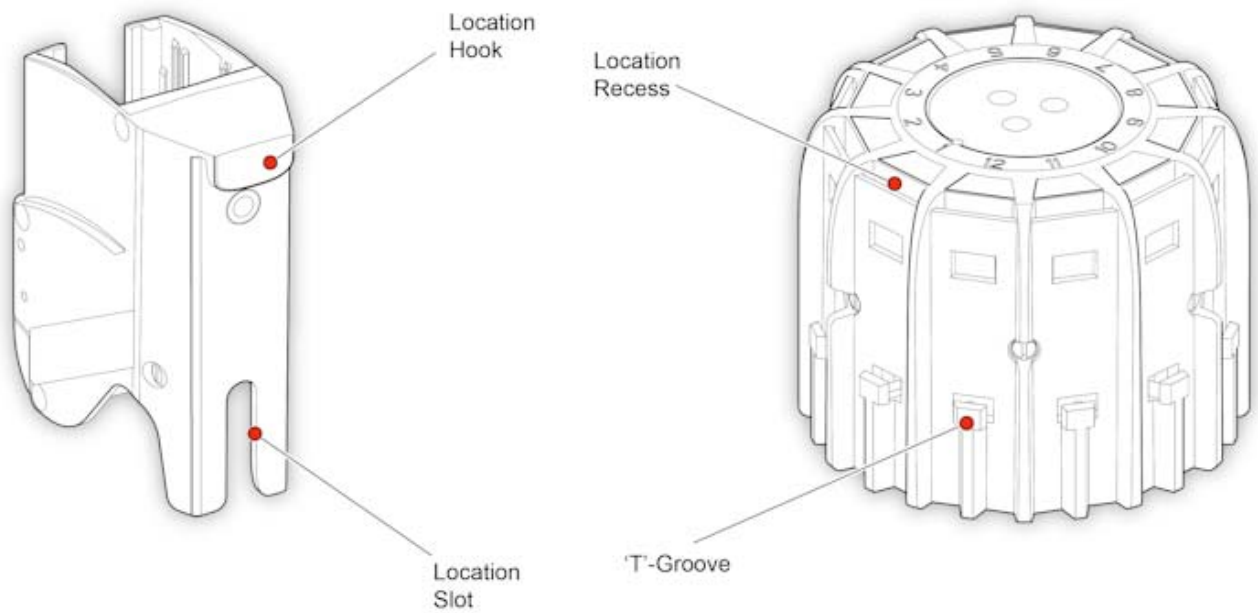

- Position the Hopper above the Carousel and lower it as shown.

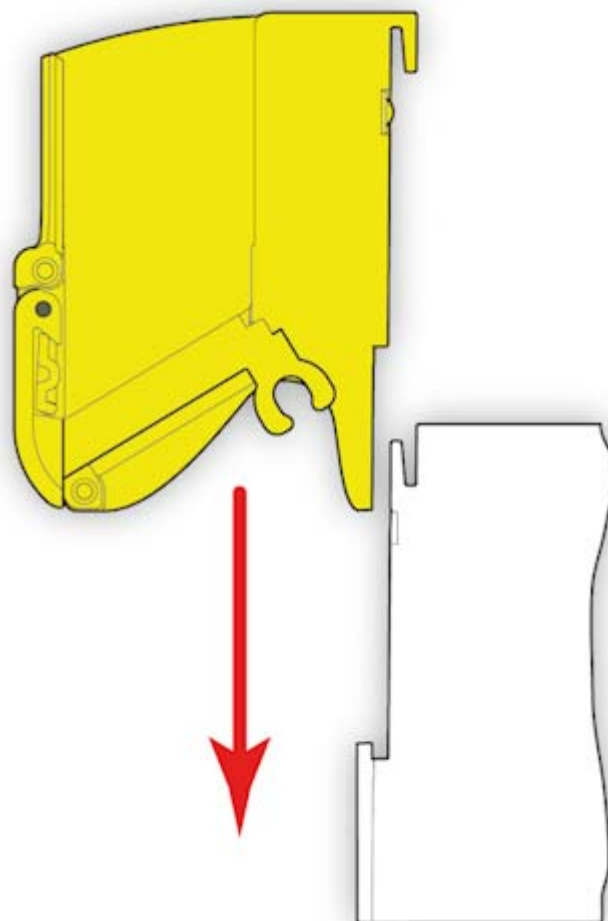

- Make sure that the following parts are fully engaged.
- Location Slot and T-Groove.
- Location Hook and Location Recess.

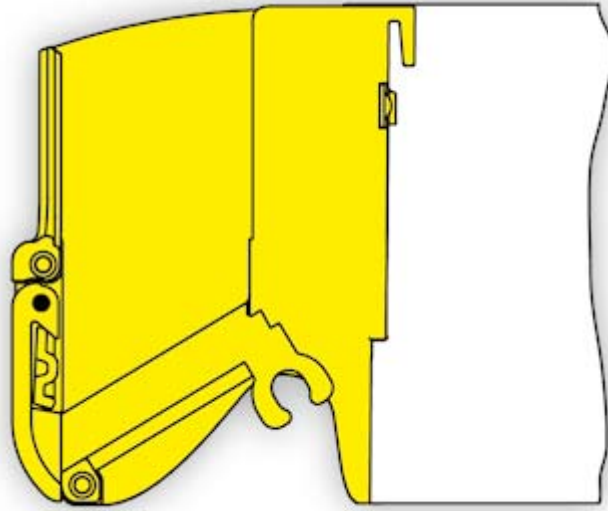

Failure to ensure all mating parts are properly engaged may cause damage to the instrument and / or the hoppers.



Ensure the hopper door is closed and the hopper slider is fully retracted before loading onto the carousel.

Changing the Foil Tape

When the Foil Tape has been used up the Touch Panel on PrintMate AS will display a message stating that the Foil Tape needs replacing.

- Remove the Used Foil Tape
- Fit the Foil Tape Roll

Removing the Used Foil Tape

To remove the used Foil Tape:

- Open the Print Door and the Waste Spool Access hatch.

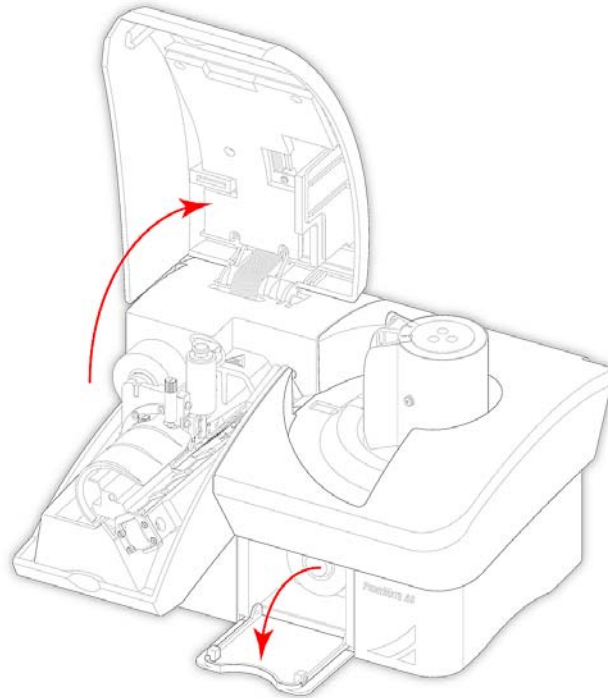

- Manually turn the Waste Spool to pull the remaining Foil Tape through the instrument.
- Remove the full Waste Spool and dispose of according to local regulations.

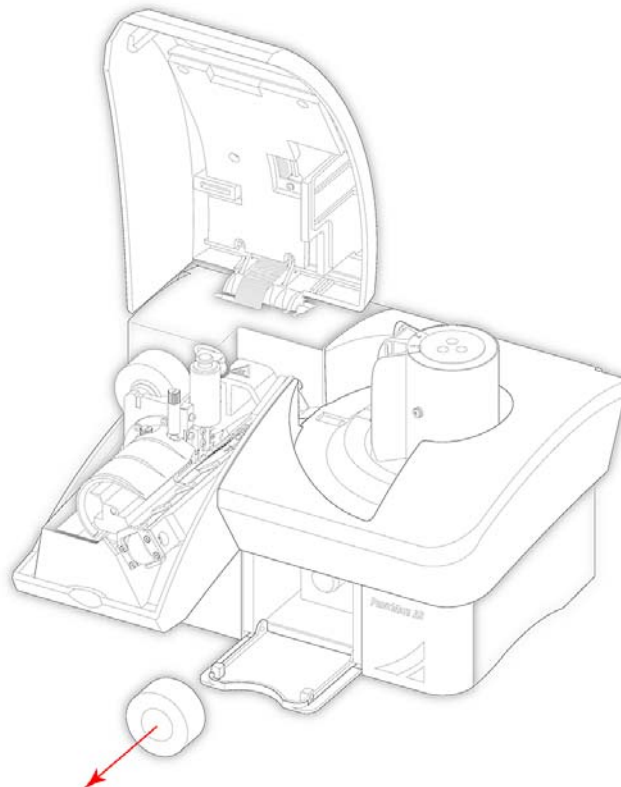

Fitting the Foil Tape Roll

Unpack a roll of Foil Tape.

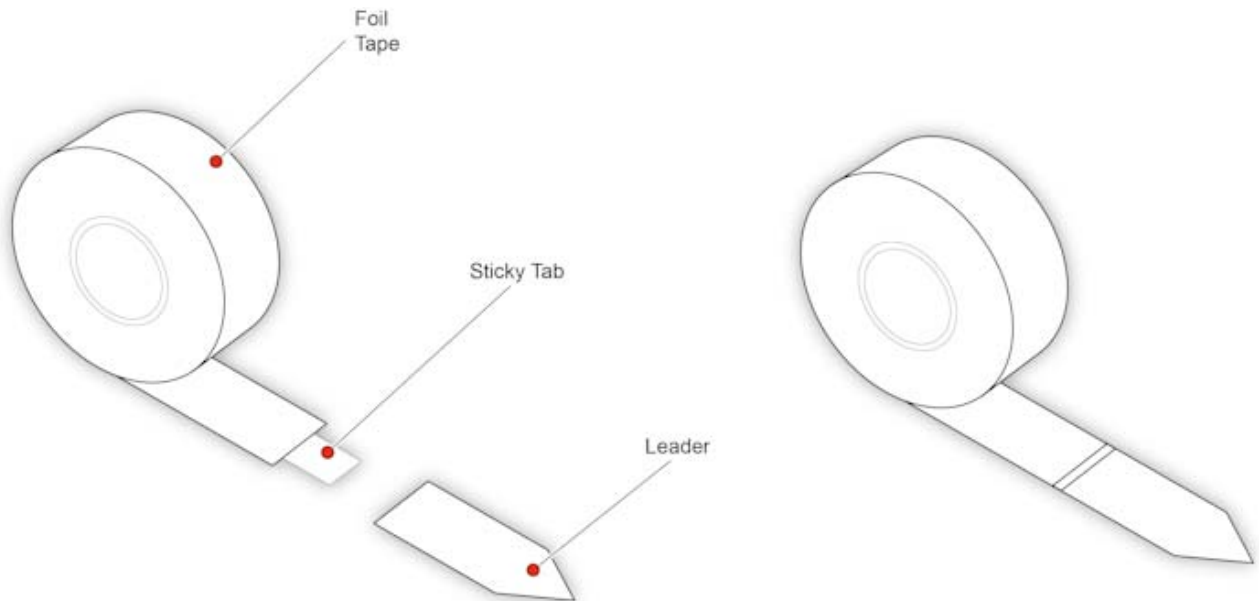

The Foil Tape has a Leader to facilitate loading, and a Sticky Tab to connect the Tape to the Leader and the Waste Spool.

Note

An empty cardboard tube is packed with the new roll of Foil Tape for use as a new Waste Spool.

To load the Foil Tape:

- Remove the Load Spool by lifting it upwards.

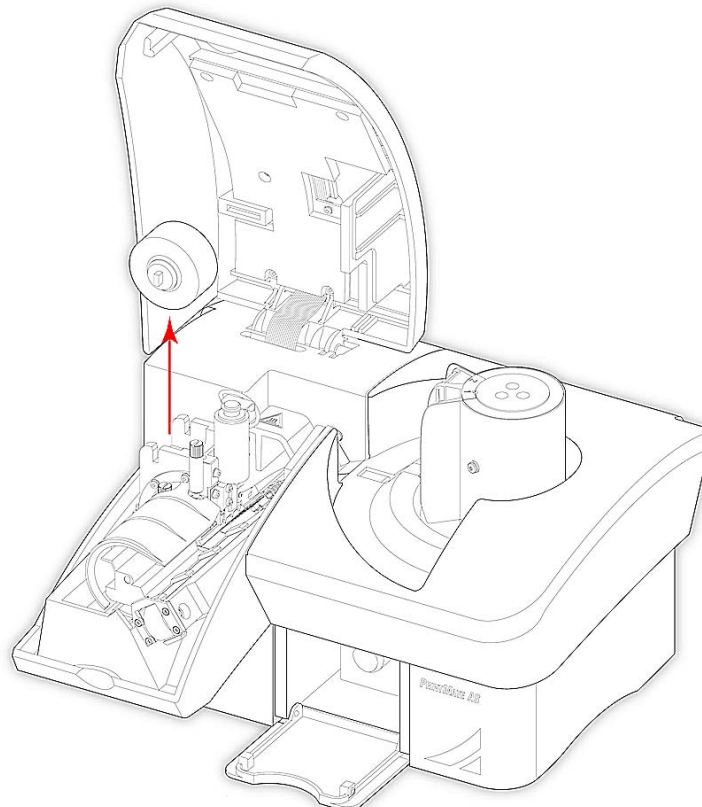

- Pull as shown, to allow the cardboard tube to slide off the Load Spool.

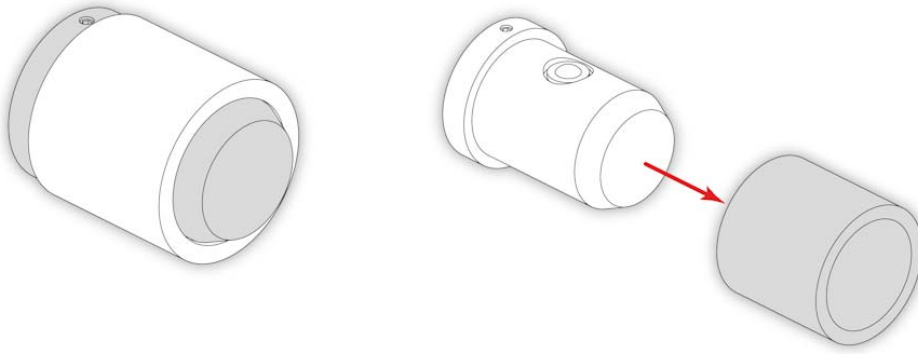

- Fit the new roll of Foil Tape by pushing it onto the Load Spool.

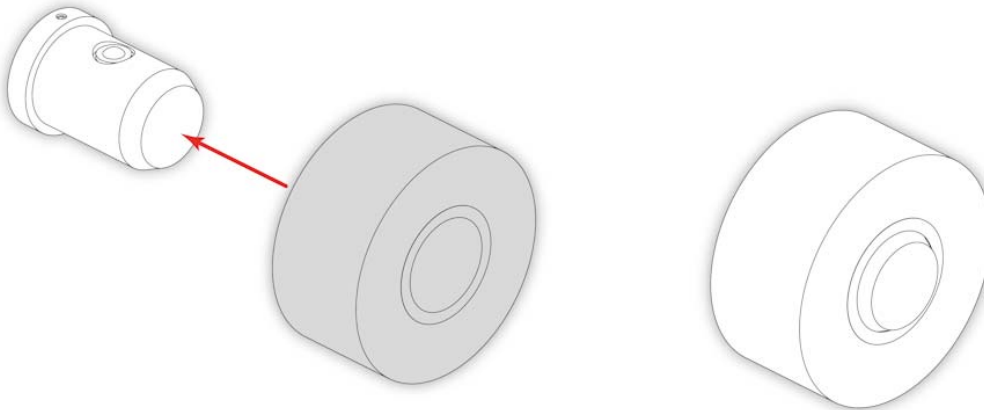

Note

Ensure the roll is pushed fully onto the Load Spool so that the retaining legs hold it securely in place.

- Fit the Load Spool and the Waste Spool as shown.

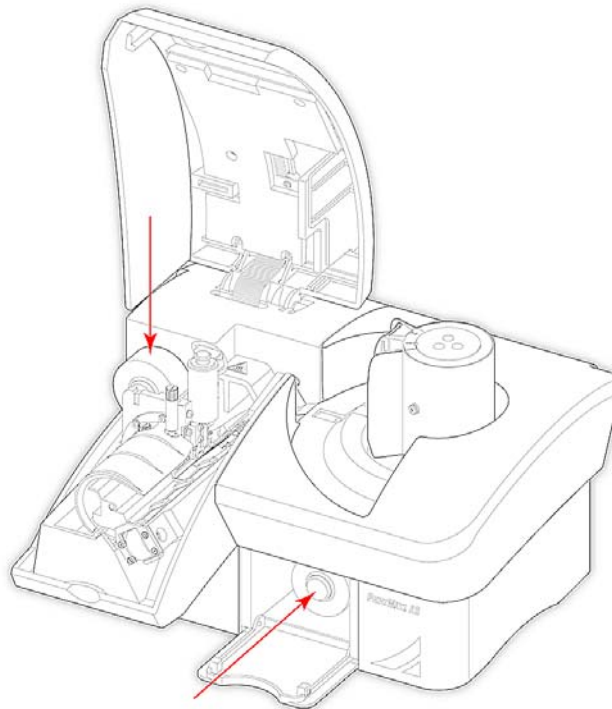

- Feed the Foil Tape Leader through PrintMate AS as shown; remove the leader and attach the lead end of the tape to the underside of the Waste Spool using the Sticky Tab.

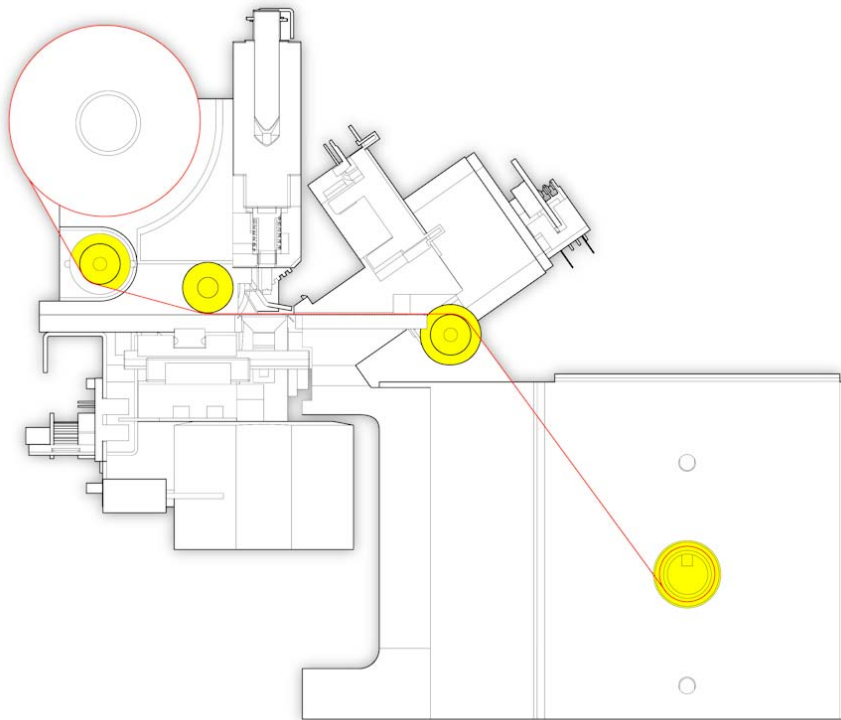

Incorrect loading of the foil tape may cause failure to print.



Do not insert objects such as pens or screwdrivers into the print head area when removing cassette jams or fitting new tape.

- Close the Print Door.

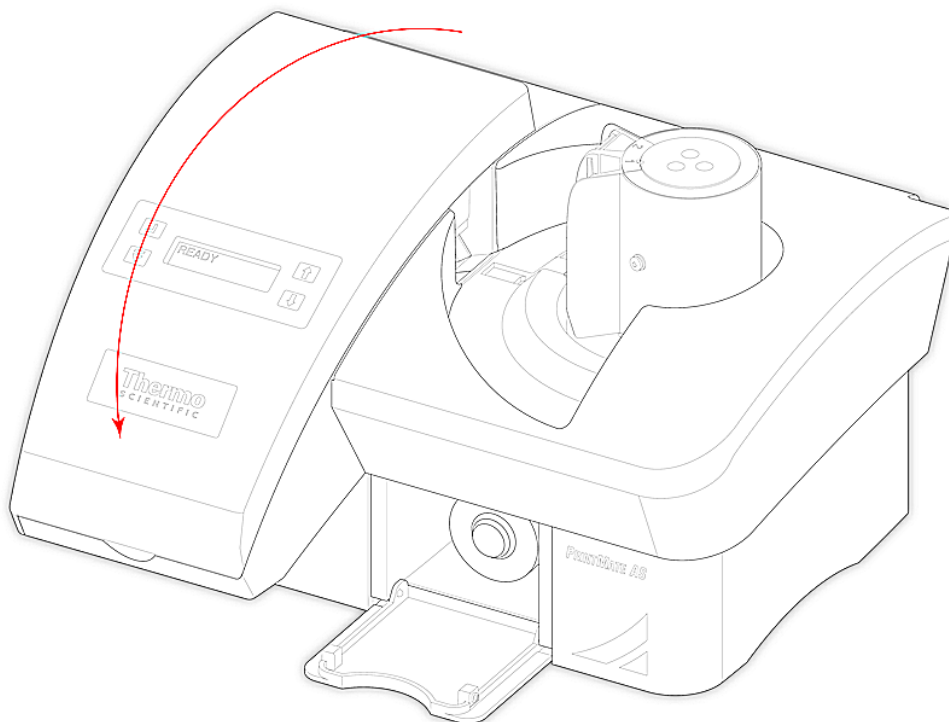

- Using the Touch Panel on PrintMate, take up the slack on the tape using the Tape Feed option.

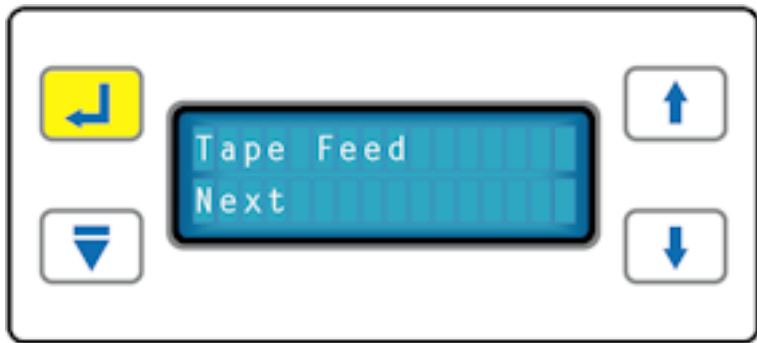

- Ensure the Foil Tape is being pulled through PrintMate by the rotating Waste Spool Shaft.
- Close the Waste Spool Access hatch.

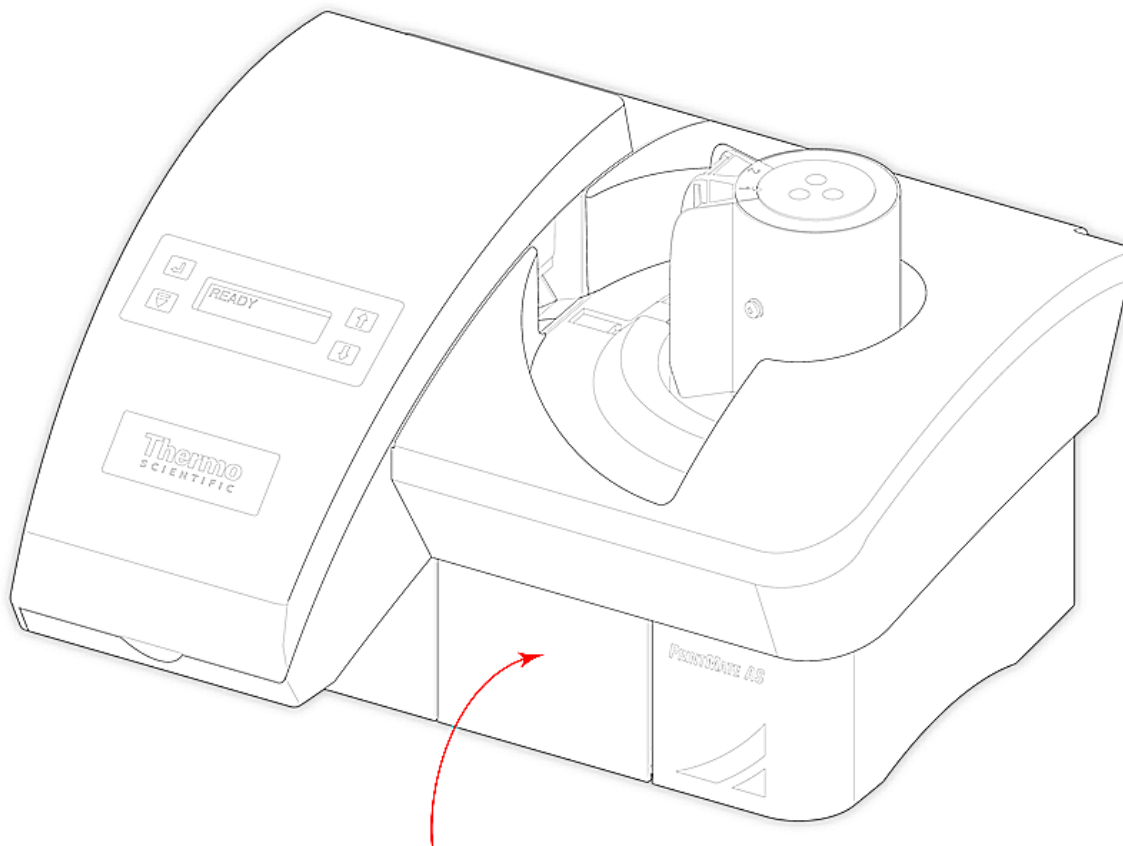

Using the Touch Panel

The Touch Panel located on the Print Door is used to perform a variety of functions.

The function of the buttons on the Touch Panel is dependant on the screen.

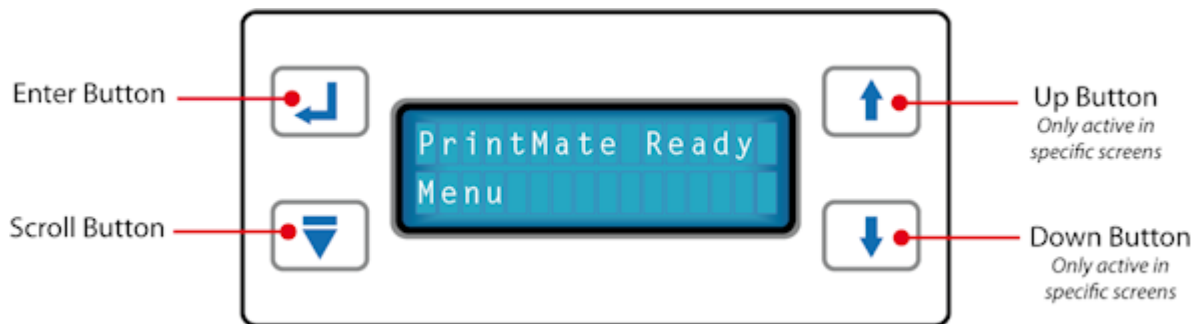

The LCD Display will indicate the function of each button as appropriate.

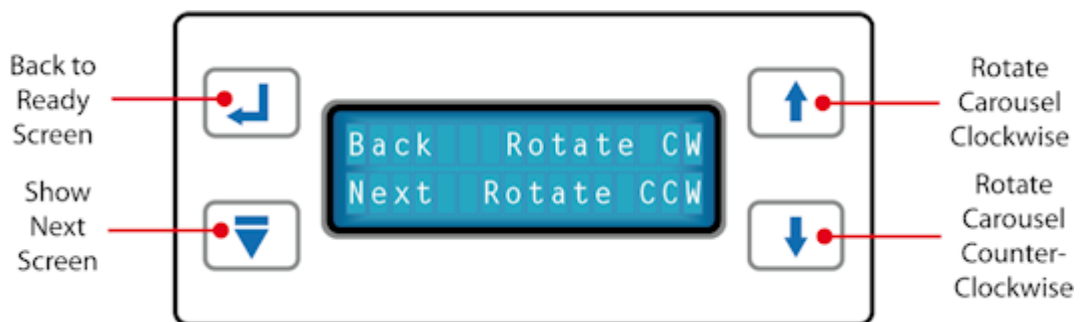

More details of specific screen operation can be found on the **Quick Reference Cards** supplied with the PrintMate AS.

Chapter 4 - Troubleshooting

- Carousel Error
- Fail to Detect Cassette
- Hopper Empty Warning Displayed When Not Empty
- Dispense Error
- Dispense Lever Fails to Reset
- Conveyor Error
- Output Error
- Output Drum Error
- Loud Knocking Noise on Power-Up
- Instrument Not Responding
- Computer Not Responding
- Tape Error
- Poor Print Quality
- No Print
- Part of Print is Missing
- Lower Line of Print is Misaligned
- Print is Faint
- Print Rubs Off Cassette Easily
- Barcodes Will Not Scan
- Print Contains Incorrect Information



Do not insert objects such as pens or screwdrivers into the print head area when removing cassette jams or fitting new tape.

Carousel Error

Error Message / Symptom	Possible Cause	Remedy
Carousel Error	Obstructions on or around the Carousel.	<ul style="list-style-type: none"> • Check for, and remove if necessary, any obstructions which may be preventing the Carousel from rotating. • Use the Touch Panel or PC to continue.
	Hopper incorrectly seated on the Carousel and catching on casework.	<ul style="list-style-type: none"> • Ensure Hoppers are correctly seated on the Carousel (see Chapter 2 - Loading Hoppers Onto the Carousel). • Use the Touch Panel or PC to continue.
	Dispense lever interfering with Hopper Slider.	<ul style="list-style-type: none"> • Remove the Hopper at the output position and use the Touch Panel or PC to perform a Dispense Cycle and reset the dispense lever. • Replace the Hopper and retry.
	Hidden obstruction.	<ul style="list-style-type: none"> • Remove all Hoppers. • Use the Touch Panel to rotate the Carousel to check for correct operation.
	Instrument Malfunction	<ul style="list-style-type: none"> • Call the Thermo Fisher Scientific Service Department.

Fail to Detect Cassette

Error Message / Symptom	Possible Cause	Remedy
Fail to detect Cassette	Cassette blockage when exiting Hopper.	<ul style="list-style-type: none"> • Open the Print Door and remove any visible Cassette. • Use the Touch Panel or PC to continue.
	Cassette blockage in Hopper.	<ul style="list-style-type: none"> • Remove the Hopper at the output position and use the Touch Panel or PC to perform a Dispense Cycle and reset the dispense lever. • Remove the Cassette Tube and / or any loose Cassettes in the Hopper. • Manually open and close the Hopper Slider a few time to ensure it moves freely. • Carefully reload the Cassettes and refit the Hopper to the Carousel. • Use the Touch Panel or PC to continue.
	Cassette not compatible.	<ul style="list-style-type: none"> • If using a non-approved Cassette, check that they manually dispense properly.
	Other Hopper Malfunction	<ul style="list-style-type: none"> • Fit another Hopper in the output position and check that it operates correctly. • If it does, this indicates that either the Cassettes or the Hopper is faulty.
	Instrument Malfunction	<ul style="list-style-type: none"> • Call the Thermo Fisher Scientific Service Department.

'Hopper Empty' Warning Displayed When Not Empty

Error Message / Symptom	Possible Cause	Remedy
Hopper Empty warning displayed when not empty	Cassette blockage when exiting Hopper.	<ul style="list-style-type: none"> • Open the Print Door and remove any visible Cassette. • Use the Touch Panel or PC to continue.
	Cassette blockage in Hopper.	<ul style="list-style-type: none"> • Remove the Hopper at the output position and use the Touch Panel or PC to perform a Dispense Cycle and reset the dispense lever. • Remove the Cassette Tube and / or any loose Cassettes in the Hopper. • Manually open and close the Hopper Slider a few time to ensure it moves freely. • Carefully reload the Cassettes and refit the Hopper to the Carousel. • Use the Touch Panel or PC to continue.
	Cassette not compatible.	<ul style="list-style-type: none"> • If using a non-approved Cassette, check that they manually dispense properly.
	Other Hopper Malfunction	<ul style="list-style-type: none"> • Fit another Hopper in the output position and check that it operates correctly. • If it does, this indicates that either the Cassettes or the Hopper is faulty.
	Instrument Malfunction	<ul style="list-style-type: none"> • Call the Thermo Fisher Scientific Service Department.

Dispense Error

Error Message / Symptom	Possible Cause	Remedy
Dispense error	Cassette blockage when exiting Hopper.	<ul style="list-style-type: none"> • Open the Print Door and remove any visible Cassette. • Use the Touch Panel or PC to continue.
	Cassette blockage in Hopper.	<ul style="list-style-type: none"> • Remove the Hopper at the output position and use the Touch Panel or PC to perform a Dispense Cycle and reset the dispense lever. • Remove the Cassette Tube and / or any loose Cassettes in the Hopper. • Manually open and close the Hopper Slider a few time to ensure it moves freely. • Carefully reload the Cassettes and refit the Hopper to the Carousel. • Use the Touch Panel or PC to continue.
	Cassette not compatible.	<ul style="list-style-type: none"> • If using a non-approved Cassette, check that they manually dispense properly.
	Securesette Hopper	<ul style="list-style-type: none"> • Using wrong hopper could cause jams
	Other Hopper Malfunction	<ul style="list-style-type: none"> • Fit another Hopper in the output position and check that it operates correctly. • If it does, this indicates that either the Cassettes or the Hopper is faulty.
	Instrument Malfunction	<ul style="list-style-type: none"> • Call the Thermo Fisher Scientific Service Department.

Dispense Lever Fails to Reset

Error Message / Symptom	Possible Cause	Remedy
Dispense lever fails to reset	Cassette blockage when exiting Hopper.	<ul style="list-style-type: none"> • Open the Print Door and remove any visible Cassette. • Use the Touch Panel or PC to continue.
	Cassette blockage in Hopper.	<ul style="list-style-type: none"> • Remove the Hopper at the output position and use the Touch Panel or PC to perform a Dispense Cycle and reset the dispense lever. • Remove the Cassette Tube and / or any loose Cassettes in the Hopper. • Manually open and close the Hopper Slider a few time to ensure it moves freely. • Carefully reload the Cassettes and refit the Hopper to the Carousel. • Use the Touch Panel or PC to continue.
	Cassette not compatible.	<ul style="list-style-type: none"> • If using a non-approved Cassette, check that they manually dispense properly.
	Other Hopper Malfunction	<ul style="list-style-type: none"> • Fit another Hopper in the output position and check that it operates correctly. • If it does, this indicates that either the Cassettes or the Hopper is faulty.
	Instrument Malfunction	<ul style="list-style-type: none"> • Call the Thermo Fisher Scientific Service Department.

Conveyor Error

Error Message / Symptom	Possible Cause	Remedy
Conveyor error	Cassette misfeed on Conveyor.	<ul style="list-style-type: none">• Open the Print Door and remove any visible Cassette.• Use the Touch Panel or PC to continue.

Output Error

Error Message / Symptom	Possible Cause	Remedy
Output error	Cassette misfeed into Output Drum.	<ul style="list-style-type: none"> • Open Print Door. • Manually rotate Output Drum and remove any Cassettes. • Check that no Cassettes are trapped under the Output Drum or Conveyor block. • Use the Touch Panel or PC to continue.
	Cassette caught on Output Chute guides.	<ul style="list-style-type: none"> • Check that Output Chutes are correctly fitted and realign if necessary (see Chapter 3 - Connecting the Output Chutes). • Check that the side-guides on the Output Chute are not bent inwards and interfering with the Cassette as it exits.

Output Drum Error

Error Message / Symptom	Possible Cause	Remedy
Output Drum error	Cassette misfeed into Output Drum.	<ul style="list-style-type: none"> • Open Print Door. • Manually rotate Output Drum and remove any Cassettes. • Check that no Cassettes are trapped under the Output Drum or Conveyor block. • Use the Touch Panel or PC to continue.
	Cassette caught on Output Chute guides.	<ul style="list-style-type: none"> • Check that Output Chutes are correctly fitted and realign if necessary (see Chapter 3 - Connecting the Output Chutes). • Check that the side-guides on the Output Chute are not bent inwards and interfering with the Cassette as it exits.

Loud Knocking Noise On Power-Up

Error Message / Symptom	Possible Cause	Remedy
Loud knocking noise on power-up	Transit Fixing has not been removed.	<ul style="list-style-type: none"> • Ensure instrument is switched off. • Open the Print Door and ensure the transit lock lever is in the unlocked position - (see Chapter 3 - Unpacking).
	Cassette trapped in unit.	<ul style="list-style-type: none"> • Open Print Door and remove any visible Cassettes. • Rotate the Output Drum to ensure it is not being obstructed by Cassettes. • Restart the instrument.
	Hopper preventing Carousel rotation.	<ul style="list-style-type: none"> • Remove all Hoppers. • Restart the instrument.

Instrument Not Responding

Error Message / Symptom	Possible Cause	Remedy
Instrument not responding	Software error.	<ul style="list-style-type: none"> • Check connections. • Switch off PrintMate AS, wait 5 seconds then switch back on. • Wait until the Touch Panel Display says PrintMate AS Ready before resuming operation. <hr/> <ul style="list-style-type: none"> • Close down the LabWriter Application and restart it. <hr/> <ul style="list-style-type: none"> • Switch off PrintMate AS. • Close down the LabWriter Application. • Reboot the PC. • Restart the LabWriter Application and PrintMate AS. • Check that the COM Port Settings for LabWriter are correct. • Check that the Baud Rate settings for LabWriter are correct: <ul style="list-style-type: none"> ▪ PrintMate 19200 ▪ PrintMate AS 57600

Computer Not Responding

Error Message / Symptom	Possible Cause	Remedy
Computer not responding	Software error.	<ul style="list-style-type: none"> • Check connections. • Close down the LabWriter Application and restart it. <hr/> <ul style="list-style-type: none"> • Hold down Ctrl + Alt + Delete to display the Windows Security dialog box. • Select Task Manager. • In the Applications Tab highlight LabWriter and select End Task. <hr/> <ul style="list-style-type: none"> • Switch off PrintMate AS. • Close down the LabWriter Application. • Reboot the PC. • Restart the LabWriter Application and PrintMate AS.

Tape Errors

Error Message / Symptom	Possible Cause	Remedy
Tape errors	Tape feed error	<ul style="list-style-type: none"> • Check whether Tape has run out and replace if necessary (see Chapter 2 - Changing the Foil Tape). • Check whether Tape is slack - use the Tape Feed function on the Touch Panel to remove any slack if present. • Check Tape is fed through instrument correctly (see Chapter 2 - Changing the Foil Tape). • Check Waste Spool rotates after each Cassette is printed - If Waste Spool does not rotate call the Thermo Fisher Scientific Service Department. • Cut Tape and remove used section from the Waste Spool. Re-feed remaining unused Tape as per Chapter 2 - Changing the Foil Tape.

Poor Print Quality

Error Message / Symptom	Possible Cause	Remedy
Poor print quality	Cassette colour.	<ul style="list-style-type: none">• Check that Cassette colour is included on Appendix C - Approved Cassette List.

No Print

Error Message / Symptom	Possible Cause	Remedy
No Print	Transit Lock Lever has not been unlocked.	<ul style="list-style-type: none"> • Switch off PrintMate AS. • Open Print Door. • Ensure the Transit Lock Lever is in the unlocked position as shown in Chapter 3 - Setting Up PrintMate.
	Cassette or debris obstructing Print Head movement.	<ul style="list-style-type: none"> • Open Print Door and check under Cassette Clamp for jammed Cassette or debris. • Remove Cassette or debris as required.
	Tape roll finished.	<ul style="list-style-type: none"> • Open Print Door and replace Tape (see Chapter 2 - Changing the Foil Tape).
	Tape jammed.	<ul style="list-style-type: none"> • Open Print Door and Waste Spool Access. • Use Tape Feed function on Touch Panel to check that Tape feeds correctly. • If Tape does not feed remove and refit Tape (see Chapter 2 - Changing the Foil Tape)
	Cassette Clamp error.	<ul style="list-style-type: none"> • Open Print Door and print a Cassette. • Check Cassette is held securely during printing and does not move until the Cassette Clamp releases it. • If movement is seen call the Thermo Fisher Scientific Service Department.
	Instrument Malfunction.	<ul style="list-style-type: none"> • Call the Thermo Fisher Scientific Service Department.

Part of Print is Missing

Error Message / Symptom	Possible Cause	Remedy
Part of print is missing.	Print Template set up incorrectly.	<ul style="list-style-type: none"> • Ask Administrator to check Print Template setup. • Use Print to Screen function to check print layout.
	Tape jammed.	<ul style="list-style-type: none"> • Open Print Door and Waste Spool Access. • Use Tape Feed function on Touch Panel to check that Tape feeds correctly. • If Tape does not feed remove and refit Tape (see Chapter 2 - Changing the Foil Tape).
	Cassette Clamp error.	<ul style="list-style-type: none"> • Open Print Door and print a Cassette. • Check Cassette is held securely during printing and does not move until the Cassette Clamp releases it. • If movement is seen call the Thermo Fisher Scientific Service Department.
	Print Head obstructed.	<ul style="list-style-type: none"> • Open Print Door and check under Cassette Clamp for debris.
	Incompatible Cassette.	<ul style="list-style-type: none"> • Check that Cassette type is included in Appendix C - Approved Cassette List.
	Instrument Malfunction.	<ul style="list-style-type: none"> • Call the Thermo Fisher Scientific Service Department.

Lower Line of Print is Misaligned

Error Message / Symptom	Possible Cause	Remedy
Lower line of print is misaligned	Print Template set up incorrectly.	<ul style="list-style-type: none"> • Ask Administrator to check Print Template setup. • Use Print to Screen function to check print layout.
	Tape jammed.	<ul style="list-style-type: none"> • Open Print Door and Waste Spool Access. • Use Tape Feed function on Touch Panel to check that Tape feeds correctly. • If Tape does not feed remove and refit Tape (see Chapter 2 - Changing the Foil Tape).
	Cassette Clamp error.	<ul style="list-style-type: none"> • Open Print Door and print a Cassette. • Check Cassette is held securely during printing and does not move until the Cassette Clamp releases it. • If movement is seen call the Thermo Fisher Scientific Service Department.
	Print Head obstructed.	<ul style="list-style-type: none"> • Open Print Door and check under Cassette Clamp for debris.
	Incompatible Cassette.	<ul style="list-style-type: none"> • Check that Cassette type is included in Appendix C - Approved Cassette List.
	Instrument Malfunction.	<ul style="list-style-type: none"> • Call the Thermo Fisher Scientific Service Department.

Print is Faint

Error Message / Symptom	Possible Cause	Remedy
Print is faint	Cassette Clamp error.	<ul style="list-style-type: none"> • Open Print Door and print a Cassette. • Check Cassette is held securely during printing and does not move until the Cassette Clamp releases it. • If movement is seen call the Thermo Fisher Scientific Service Department.
	Tape jammed.	<ul style="list-style-type: none"> • Open Print Door and Waste Spool Access. • Use Tape Feed function on Touch Panel to check that Tape feeds correctly. • If Tape does not feed remove and refit Tape (see Chapter 2 - Changing the Foil Tape).
	Incompatible or old Tape.	<ul style="list-style-type: none"> • Replace Tape with approved spare (see Appendix A - Spares and Accessories).
	Incompatible Cassette.	<ul style="list-style-type: none"> • Check that Cassette type is included in Appendix C - Approved Cassette List.
	Instrument Malfunction.	<ul style="list-style-type: none"> • Call the Thermo Fisher Scientific Service Department.

Print Rubs Off Cassette Easily

Error Message / Symptom	Possible Cause	Remedy
Print rubs off Cassette easily	Cassette Clamp error.	<ul style="list-style-type: none"> • Open Print Door and print a Cassette. • Check Cassette is held securely during printing and does not move until the Cassette Clamp releases it. • If movement is seen call the Thermo Fisher Scientific Service Department.
	Tape jammed.	<ul style="list-style-type: none"> • Open Print Door and Waste Spool Access. • Use Tape Feed function on Touch Panel to check that Tape feeds correctly. • If Tape does not feed remove and refit Tape (see Chapter 2 - Changing the Foil Tape).
	Incompatible or old Tape.	<ul style="list-style-type: none"> • Replace Tape with approved spare (see Appendix A - Spares and Accessories).
	Incompatible Cassette.	<ul style="list-style-type: none"> • Check that Cassette type is included in Appendix C - Approved Cassette List.
	Instrument Malfunction.	<ul style="list-style-type: none"> • Call the Thermo Fisher Scientific Service Department.

Barcodes Will Not Scan

Error Message / Symptom	Possible Cause	Remedy
Barcodes will not scan	Print Template set up incorrectly.	<ul style="list-style-type: none"> • Ask Administrator to check Print Template setup. • Use Print to Screen function to check print layout.
	Barcode Reader Error.	<ul style="list-style-type: none"> • Refer to your barcode readers instructions manual.
	Cassette Clamp Error.	<ul style="list-style-type: none"> • Open Print Door and print a Cassette. • Check Cassette is held securely during printing and does not move until the Cassette Clamp releases it. • If movement is seen call the Thermo Fisher Scientific Service Department.
	Software Error.	<ul style="list-style-type: none"> • Call the Thermo Fisher Scientific Service Department.
	Instrument Malfunction.	<ul style="list-style-type: none"> • Call the Thermo Fisher Scientific Service Department.

Print Contains Incorrect Information

Error Message / Symptom	Possible Cause	Remedy
Print contains incorrect information	Print Template set up incorrectly.	<ul style="list-style-type: none"> • Ask Administrator to check Print Template setup. • Use Print to Screen function to check print layout.
	Software error.	<ul style="list-style-type: none"> • Call the Thermo Fisher Scientific Service Department.
	Instrument Malfunction.	<ul style="list-style-type: none"> • Call the Thermo Fisher Scientific Service Department.

Chapter 5 - Cleaning and Maintenance

Cleaning and Maintenance

Cleaning Procedure.

Changing Fuses.

Cleaning Procedure

To ensure continuous reliable operation the following cleaning procedures should be carried out on a weekly basis:

- Use damp cloth and a 10% commercial, Hypochlorite bleach solution in water to wipe the outer covers and output chutes (if fitted).



Never use solvents on the covers as these may discolour the plastic parts.

- Use a vacuum cleaner with a non-metallic nozzle to remove any accumulated dust from the internal areas.



Cassette pre-heat area may be hot.

Note

Before carrying out any cleaning or maintenance procedures the user must have read and understood the following statements:



If the Instrument has been used with, or has come into contact with, hazardous material, ensure that the appropriate decontamination procedures have been followed (See World Health Organization Laboratory Biosafety Manual)



Cleaning or decontamination methods, other than those recommended in this document, should be checked with a Thermo Fisher Scientific agent to ensure that they will not damage the instrument.



Always wear suitable protective coverings when carrying out cleaning using chemicals.



Do not use chemicals which may interact with the materials of manufacture - If in doubt contact your Thermo Fisher Scientific agent.



Do not use hypochlorites in strong solution.



Do not use abrasive compounds or metal components to clean the Instrument or its accessories.



Always clean up spills immediately.



In the event of a major spillage on or around the Instrument, immediately disconnect the instrument from the Mains supply, and do not reconnect until the instrument has been thoroughly dried and checked by a Thermo Fisher Service Engineer.



Potentially lethal voltages in excess of 110VAC are present within the Instrument - Do not remove any access covers.



Disconnect the Instrument from the Mains before cleaning.



Inspect the instrument for obvious damage or wear whenever it is being cleaned.

Changing Fuses

To replace the fuses:

- Disconnect the Power Lead from the Mains Power Supply.
- Remove the Power Lead from the Power Connector.

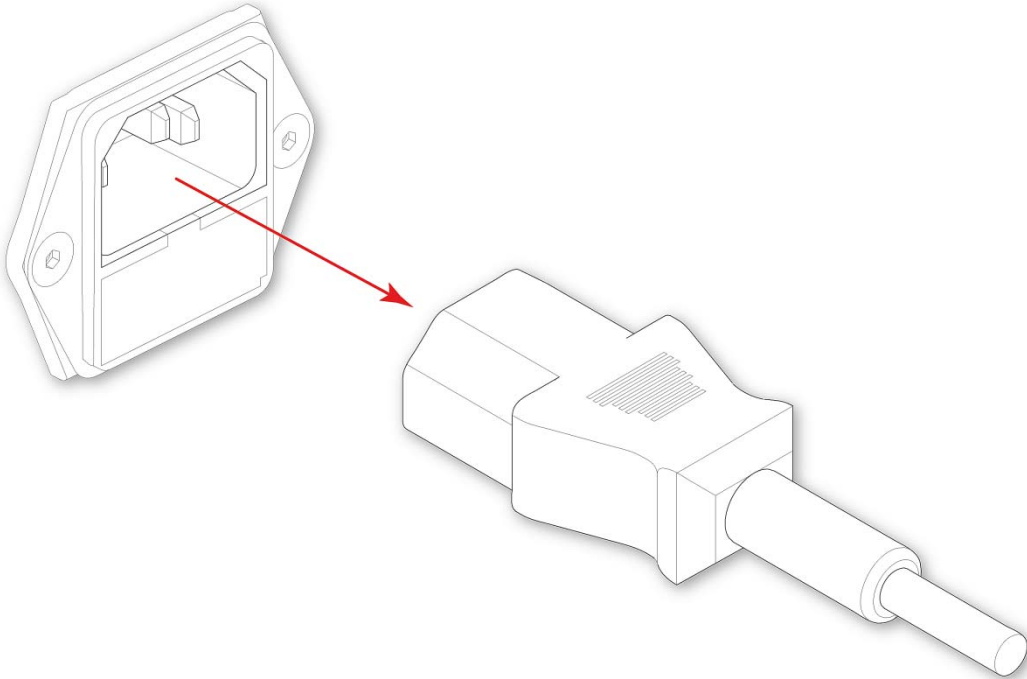

- Remove the Fuse Drawer.

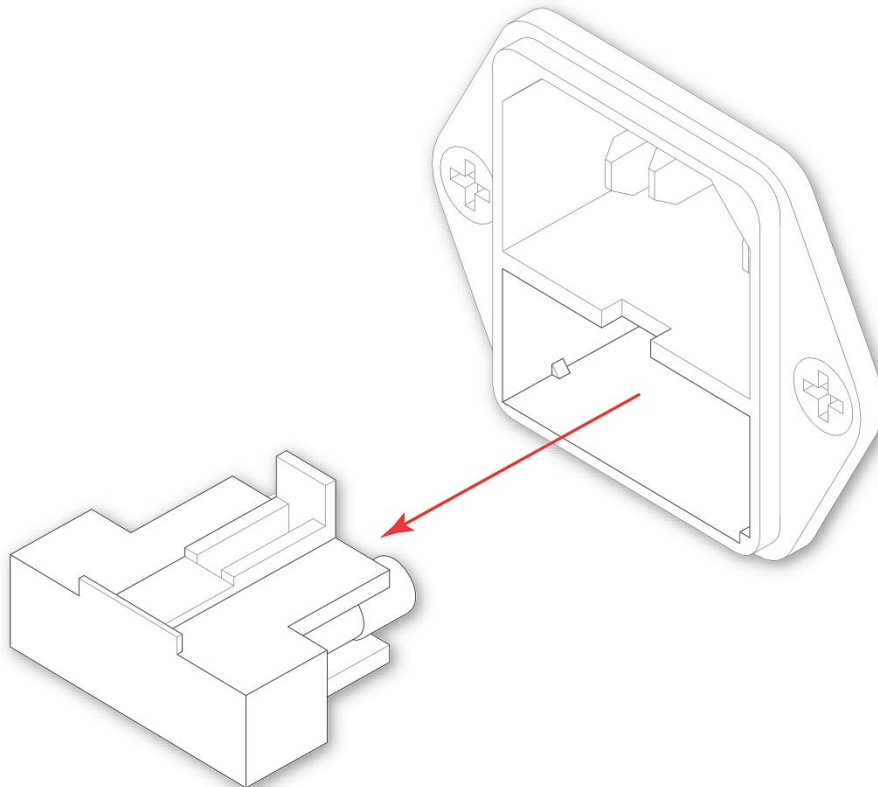

- Remove the Fuses.

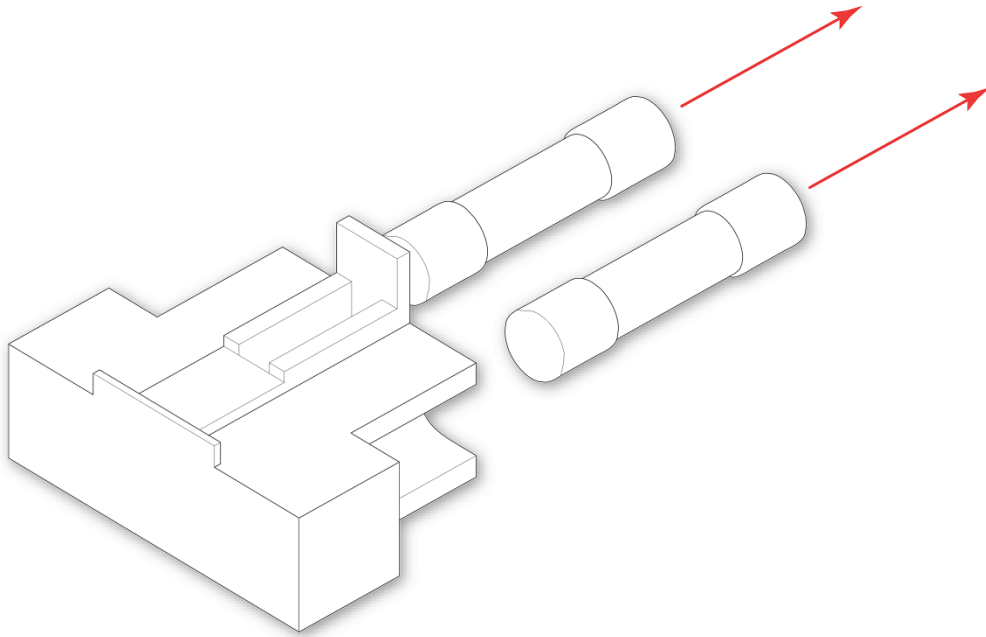

- Replace with approved Fuses ([see Appendix A](#)).

Note

Always replace fuses as a pair.

Only a technically competent person should replace fuses.

Appendices

Appendix A - Spares and Accessories

Spares and Accessories list

Item	Order Number
Hot Foil Tape (Pk. of 5)	A79510013
Collection System	A79510014
Basic LabWriter Software CD	A79510018
PC with Pre-loaded LabWriter Software	A79510021
Collection Trays (Pk. of 4) STD Cassettes only	A79510022
Guide Chute with Extension	PM 'AS' Version - A82810024
Hopper (1 off)	A79510024
PrintMate AS Operator Guide	A83810100
LabWriter Operator Guide	A82810105
Fuse Kit	A79510045

Note

Collection System - A82810113 - For use with standard approved cassette types only.

Appendix B - Repacking Instructions

Note

Before repacking the PrintMate AS use the Touch Panel to move the Print Head to the Transit position, then move the transit lock back from the stored position to the locked position.

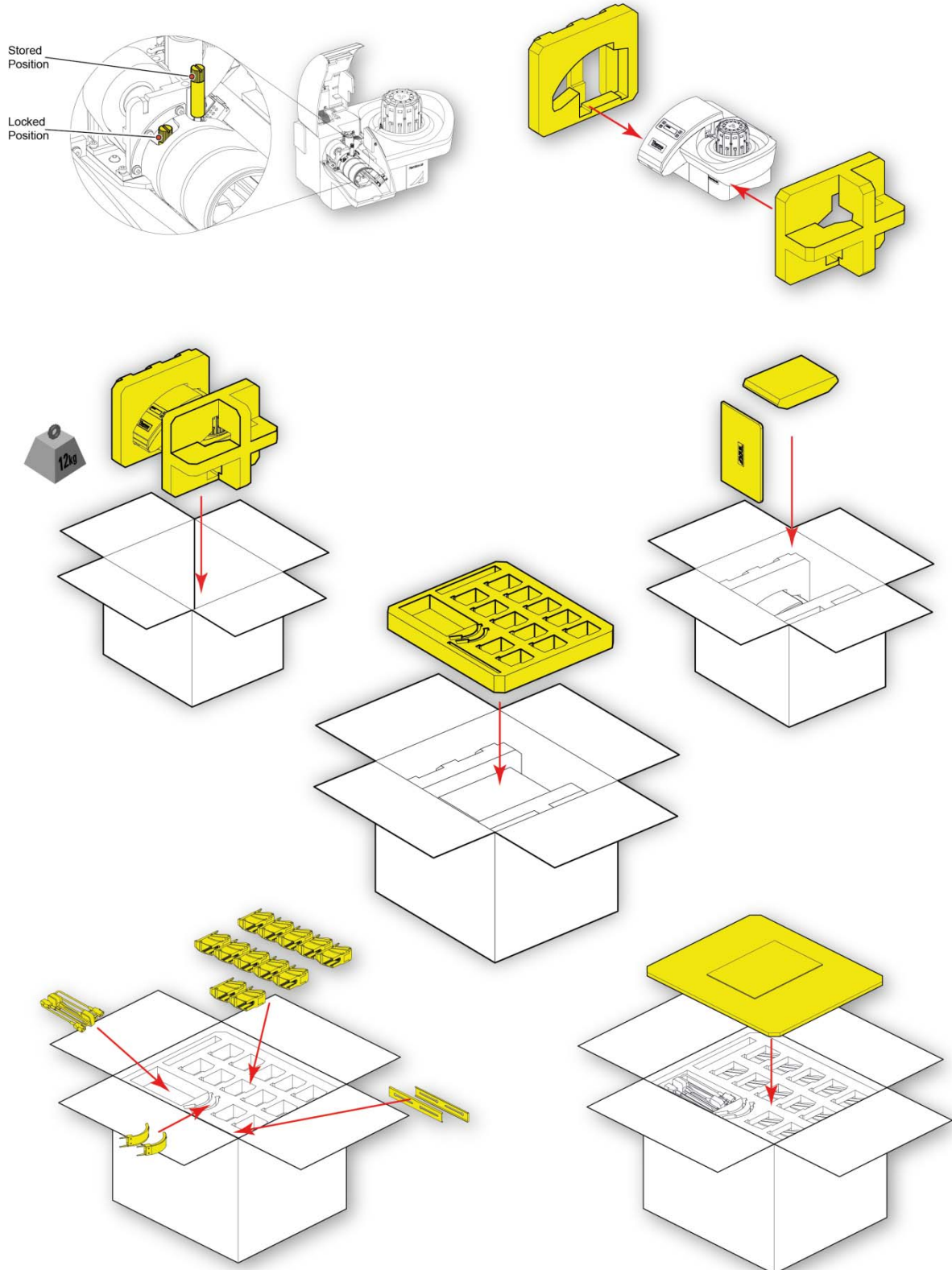

Appendix C - Approved Cassette List

Approved Cassette Types

The following Cassette types have been approved for use with the Thermo Scientific PrintMate AS:

- Thermo Scientific Biopsy Processing/Embedding Cassette Type II
- Thermo Scientific Processing/Embedding Cassette Type II
- Thermo Scientific Embedding Cassette
- Thermo Scientific Tissue Cassette Type IV
- Thermo Scientific Microsette Biopsy Cassettes
- Thermo Scientific Micromesh Biopsy Cassette
- Thermo Scientific Cassette (with attached lid)



Use of Cassettes not on this list may cause poor performance and / or damage to the instrument.

Approved Cassette Colours

- White (WH)
- Pink (PK)
- Green (GR)
- Yellow (YW)
- Blue (BL)
- Grey (GY)
- Orange (OR)
- Peach (PE)
- Tan (TN)
- Lilac (LI)
- Aqua (AQ)
- Fluorescent Green (FGR)
- Fluorescent Pink (FPK)
- Fluorescent Yellow (FYW)



Use of colours not listed above may cause print to become unreadable.

Index

Appendices.....	75, 76, 77	Spares List.....	75
Appendix A - Spares and Accessories	75	Start Up procedure	20
Appendix B - Repacking Instructions	76	System Interaction	11
Appendix C - Approved Cassette List	77	System Specification	12
Approved Cassette List	77	Touch Panel	45
Basic Operation.....	29	Troubleshooting	47
Cleaning.....	69, 70	Troubleshooting	
Cleaning and Maintenance.....	69	Carousel Error	48
Cleaning Procedure.....	70	Troubleshooting	
COM Port Settings	25	Fail to Detect Cassette.....	49
Changing the COM port settings.....	25	Troubleshooting	
Electrical Connections.....	20	'Hopper Empty' warning displayed when not empty.....	50
Foil Tape.....	39, 40, 41	Troubleshooting	
Changing Foil Tape	39	Dispense Error.....	51
Fitting the foil tape	41	Troubleshooting	
Removing the used foil tape	40	Dispense Lever Fails to Reset.....	52
Fuses	72	Troubleshooting	
Changing Fuses.....	72	Conveyor Error	53
Hoppers	37	Troubleshooting	
How to use this guide.....	3	Output Error.....	54
Identification of Parts	8	Troubleshooting	
Installation and Setup.....	13	Output Drum Error	55
Introduction.....	7	Troubleshooting	
Loading.....	30, 31, 34, 36, 37	Loud Knocking Noise on Power Up.....	56
Loading cassette tubes with hopper in-situ.....	34	Troubleshooting	
Loading cassettes tubes with hopper removed.....	31	Instrument not Responding.....	57
Loading hoppers onto the carousel	37	Troubleshooting	
Loading single cassettes into hoppers	36	Computer not Responding.....	58
Locating PrintMate ES	19	Troubleshooting	
Maintenance.....	69	Tape Errors	59
Output Chutes	22	Troubleshooting	
Connecting the Output Chutes.....	22	Poor Print Quality.....	60
PrintMate ES product range.....	5	Troubleshooting	
Setting up PrintMate ES.....	14		

No Print	61	Troubleshooting	
Troubleshooting		Print rubs off cassette easily	65
Part of Print is Missing.....	62	Troubleshooting	
Troubleshooting		Barcodes will not scan.....	66
Lower Line of Print is Misaligned	63	Troubleshooting	
Troubleshooting		Print contains incorrect information.....	67
Print is Faint	64	Unpacking.....	15