



THIS PRODUCT MUST BE INSTALLED IN ACCORDANCE WITH THE APPLICABLE INSTALLATION CODE BY A PERSON FAMILIAR WITH THE CONSTRUCTION AND OPERATION OF THE PRODUCT AND THE HAZARDS INVOLVED

CE PRODUIT DOIT ÊTRE INSTALLÉ SELON LE CODE D'INSTALLATION PERTINENT, PAR UNE PERSONNE QUI CONNAÎT BIEN LE PRODUIT ET SON FONCTIONNEMENT AINSI QUE LES RISQUES INHÉRENTS

I. Introduction

This manual is for the installation of solar kits **SLR-80-84** and **SLR-120-84**. For instructions on installing the anchor bolts into the foundation, see the **Tower Anchor Bolt Installation Instructions for ETP-MTE Series and ETP-MT/R Series towers**.

II. Package Contents

Before beginning installation, make sure you have all the included components. Each **ETP-MTE-WP** and **ETP-MT/R OP SOLAR** tower consists of the following packages: Packages 1 and 2 contain the tower enclosure and wireless pole mount. Package 3 contains the anchor bolts and template for foundation preparation. Package 4 labeled **TOWER PTS SOLAR** contains the lighting and hardware for tower assembly. Package 5 contains either solar kit **SLR-80-84** or **SLR-120-84**. **Emergency phones and wireless communication devices are sold and shipped separately.**

Package 3: MT BOLT KIT

Qty.	Part Number	Description
4	42838	J-bolts
1	26301	MT Cardboard Template

OR

MT/R BOLT KIT

Qty.	Part Number	Description
4	42838	J-bolts
1	26312	MT/R Cardboard Template

Package 4: TOWER PTS SOLAR

Qty.	Part Number	Description
8	42839	3/4"-10 Hex Nut
8	42840	3/4" Washer
3	42841	10-24 x 3/4" pan head tamperproof screw
2	42843	6-32 hex nut
1	67478	Polycarbonate light cover
1	68590	LED light board (12-24V AC/DC - 120VAC)
1	ETP-EL12/24	12/24V AC/DC LED Blue Light

Package 5: SLR-80-84 and SLR-120-84

Qty.	Part Number	Description
2	68594	42 Ah batteries
1	68681	Solar Controller
2	42855	10-24 Screws for mounting Solar Controller
2	42847	10-24 Nuts for mounting Solar Controller
6	67547	Terminal - Spade/Fork, #6 Tab, 12-10 AWG
20 ft	19678	Cable, Solar - 12AWG, Tray Cable, 2C, Black-Red
6	67545	Terminal - Ring , 0.25", 12-10 AWG
EITHER		
1	68689	PV (photovoltaic) Module, 80W 12VDC (SLR-80-84 only)
1	24701	Panel Mounting Bracket for SLR-80-84
OR		
1	68680	PV (photovoltaic) Module, 120-140W 12VDC (SLR-120-84 only)
1	24705	Panel Mounting Bracket for SLR-120-84

24701: SLR-80-84 Panel Mounting Bracket Kit

Qty.	Description
1	Large Bucket (Bracket)
1	Small Bucket (Bracket)
3	Hose Clamp
1	Clip – Left (Bracket)
1	Clip – Right (Bracket)
2	Mounting Rail
2	C-Bracket
2	Support Channel – Inner
2	Support Channel – Outer
10	1/4-20 x 3/4" SS hex-cap bolt
2	1/4-20 x 2" SS hex-cap bolt
2	1/4-20 x 1 5/8" SS hex-cap bolt
16	1/4 flat washer, SS
4	1/4 split lock washer, SS
12	1/4-20 hex nut, SS
4	5/16-18 x 3/4" SS hex-cap bolt
8	5/16 flat washer, SS
4	5/16 split lock washer, SS
4	5/16 hex nut, SS
1	1/4-20 and 5/16 x 3/4" Spare Kit

24705: SLR-120-84 Panel Mounting Bracket Kit

Qty.	Description
2	Bucket (Bracket)
4	Hose Clamp
2	Clip -Left (Bracket)
2	Clip -Right (Bracket)
2	Mounting Rail
4	Support Rail
4	1/4-20 x 3/4" SS hex-cap bolt
4	1/4 flat washer, SS
8	1/4 split lock washer, SS
4	1/4 hex nut, SS
22	5/16-18 x 3/4" SS hex-cap bolt
44	5/16 flat washer, SS
22	5/16 split lock washer, SS
22	5/16 hex nut, SS
1	1/4-20 and 5/16 x 3/4" Spare Kit

III. Tower Enclosure Installation

1. Remove the tower's rear bottom access panel by removing tamper-proof screws.
2. Install one 3/4" leveling nut and one washer on each anchor bolt 2 1/2" - 3 1/2" above grade and verify that nuts are level (0° pitch) as shown in **Figure 1**.

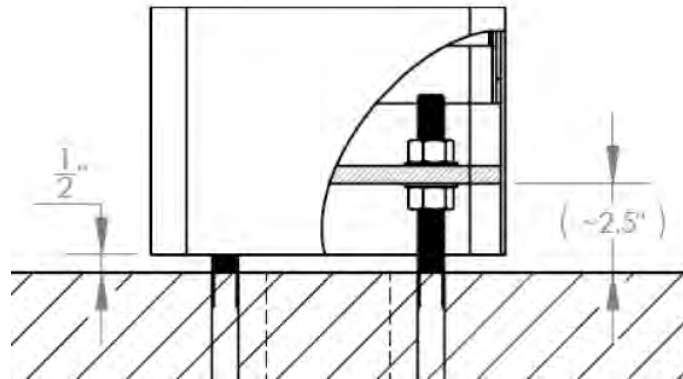

Figure 1. Tower Enclosure Installation

3. Install the tower onto the leveling bolts with the emergency phone opening oriented in the direction desired. Install the second set of nuts and washers. Tighten the upper fastening nuts; the bottom set is only for leveling.

IV. Solar Panel Installation

1. Lay the solar panel face down on a protected flat surface.
2. Place the mounting rails on the back of the panel so the lip of the rail containing the panel mounting slots/holes are facing the center of the panel as shown in **Figure 2**. Align one end of the rails to be approximately flush with the bottom edge of the panel.

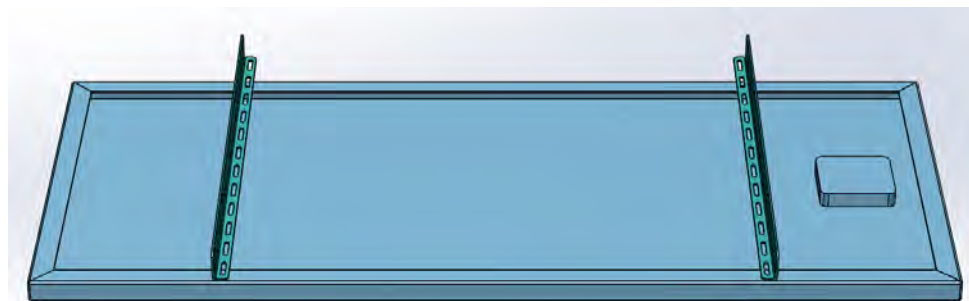

Figure 2. Mounting rails placed on rear surface of solar panel

3. Secure the mounting rails with a 1/4 - 20 x 3/4" bolt, flat washer, lock washer and hex nut in each of the panel mounting holes (4 per panel) as shown in the **Figure 3**. Tighten the bolts to **7 ft-lbs**.

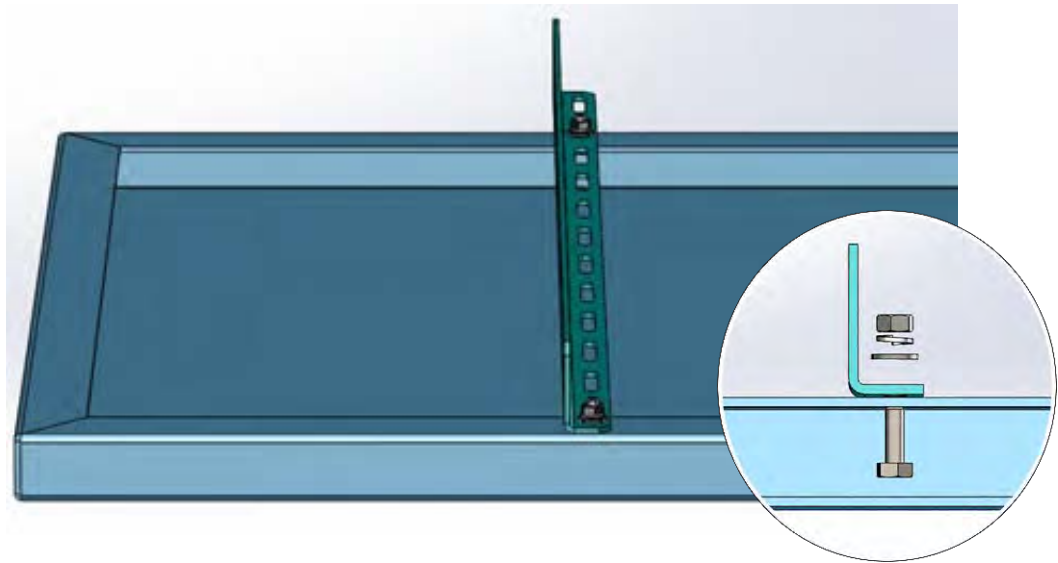

Figure 3. Mounting rail fastened to the panel frame

4. Attach the clips to the rails so that the flanged end containing the slots on the clips are facing the center of the panel as shown in **Figure 4**.



Figure 4. Orientation of clips with reference to solar panel

5. Attach the clips to the rails. In each of the mounting holes, use a 5/16 - 18 x 3/4" bolt and flat washer on one side and a flat washer, lock washer and nut on the other as shown in **Figures 5 & 6**. Tighten the bolts to hold in place securely.

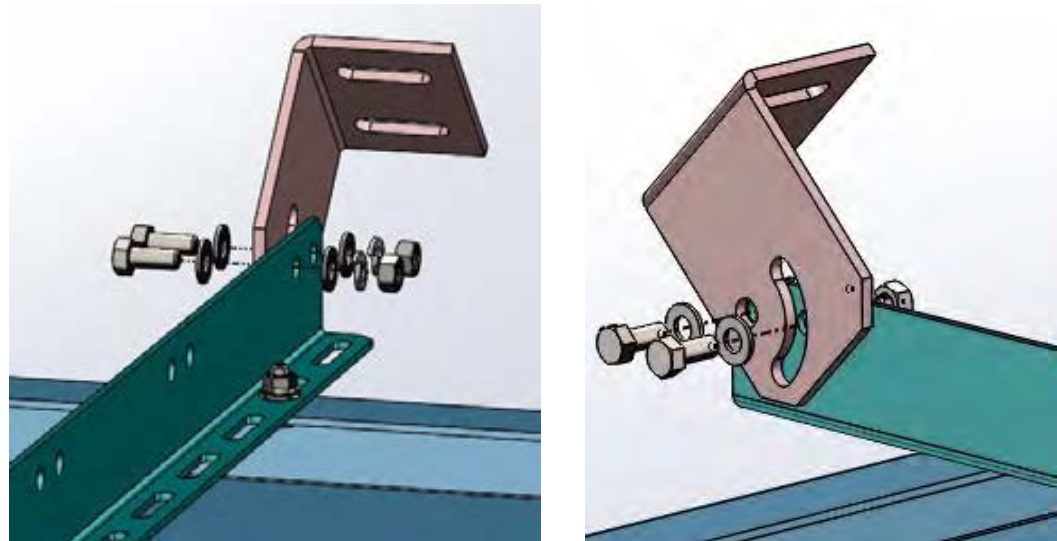

Figure 5. Exploded view of left clip attached to the left mounting rail

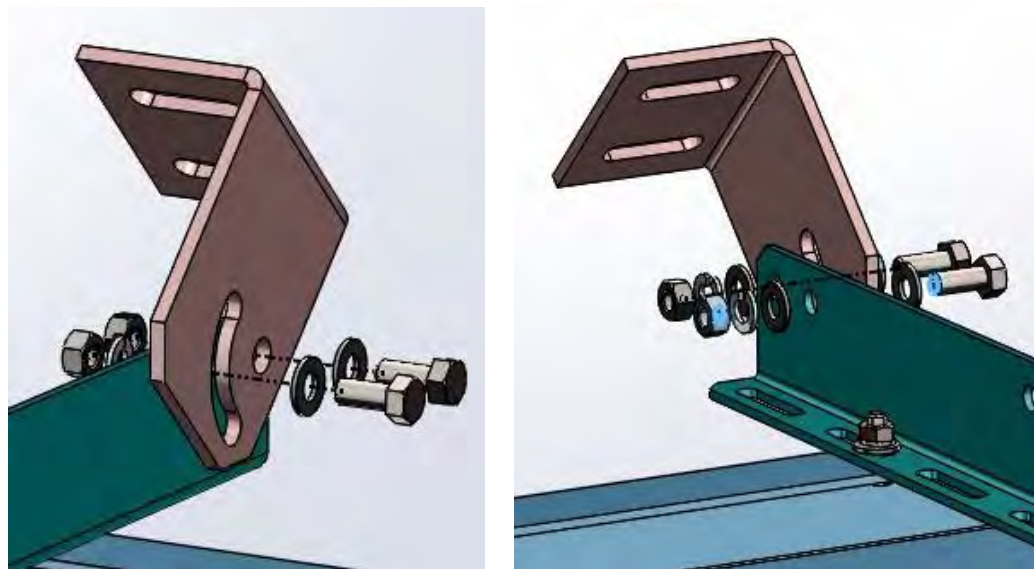

Figure 6. Exploded view of right clip attached to the right mounting rail

6. To install the bucket brackets, thread each hose clamp through one of the sets of narrow center holes as shown in **Figure 7**. Place the buckets at the desired location on the pole approximately 18 inches apart. The spacing can be adjusted later. Tighten the hose clamp screws to **70 in-lbs**.

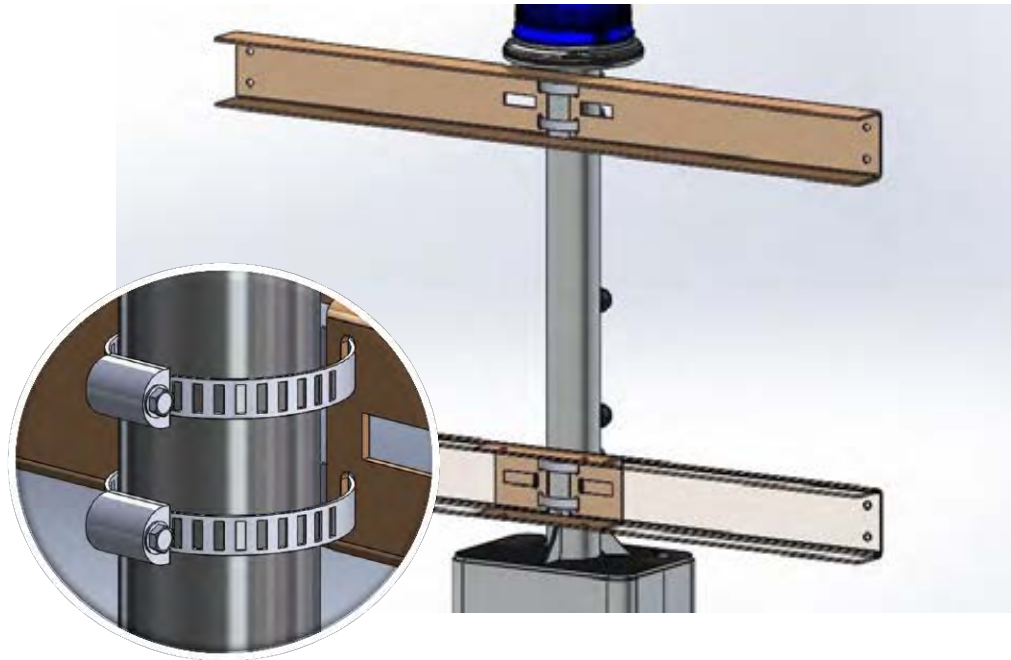

Figure 7. Mounting buckets attached to the pole using hose clamps



For countries in the northern hemisphere (U.S.A., Canada, Mexico) all solar panels should be installed facing south.

7. Place the solar panel assembly so the slots on the clips line up with holes inside of the bucket as shown in **Figure 8**. Bolt the clips to the bucket using 5/16 - 18 x 3/4" hex cap bolt and flat washer on one side, and a washer, lock washer and nut on the other. Tighten the bolts to **12 ft-lbs**.

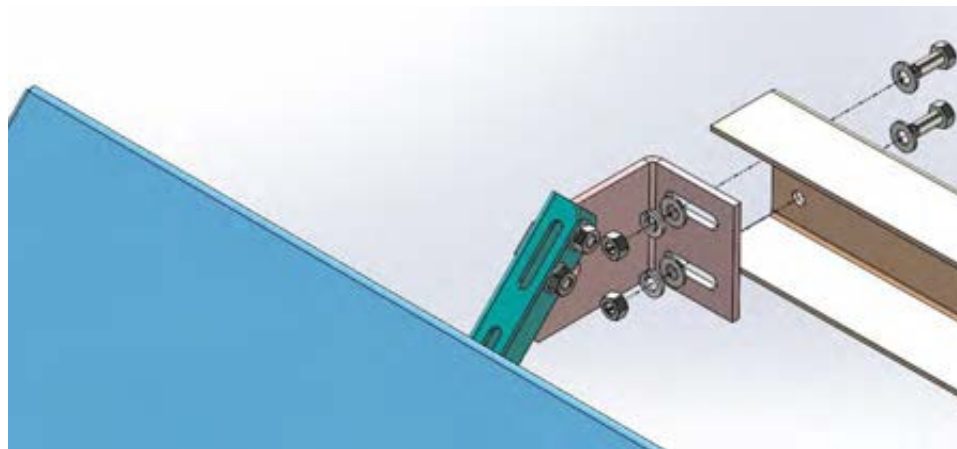

Figure 8. Exploded view of the right side clip installed to the upper bucket bracket

8. Refer to **Appendix A** for correct tilt angle according to geographic location. To adjust the tilt angle loosen the bolts holding the mounting rails to the clips and adjust the tilt of the panel as shown in **Figure 9**. Retighten the bolts to **12 ft-lbs**.

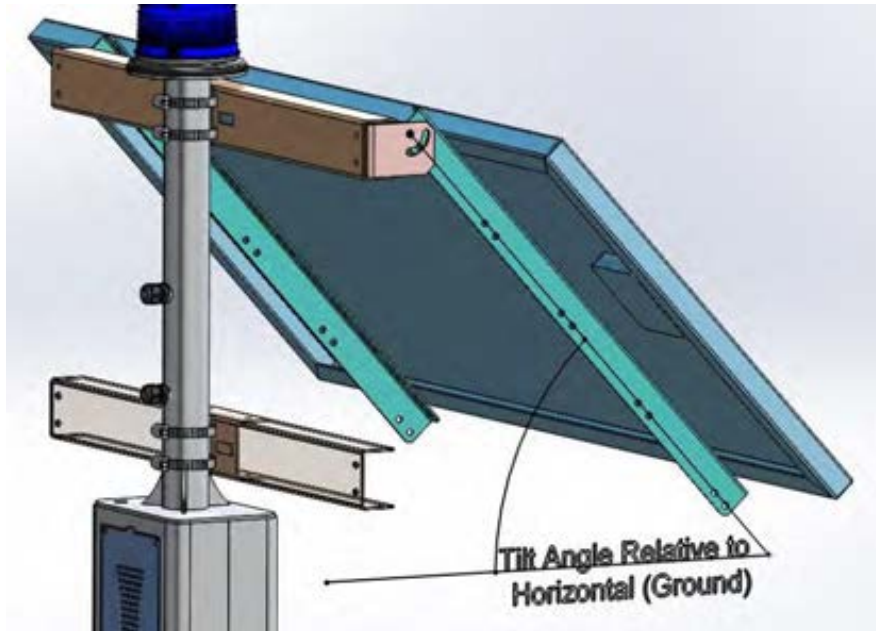

Figure 9. Panel tilt angle reference



Steps 9 – 12 are for solar kit SLR-80-84 only. For solar kit SLR-120-84, skip to step 13.

9. Attach the C-brackets to the inside face of the mounting rails using a 1/4-20 x 3/4" hex bolt and washer through one of the center holes as shown in **Figure 10**. Tighten the bolt securely so that the C-bracket flanges are level and with the flanges of the lower bucket bracket.

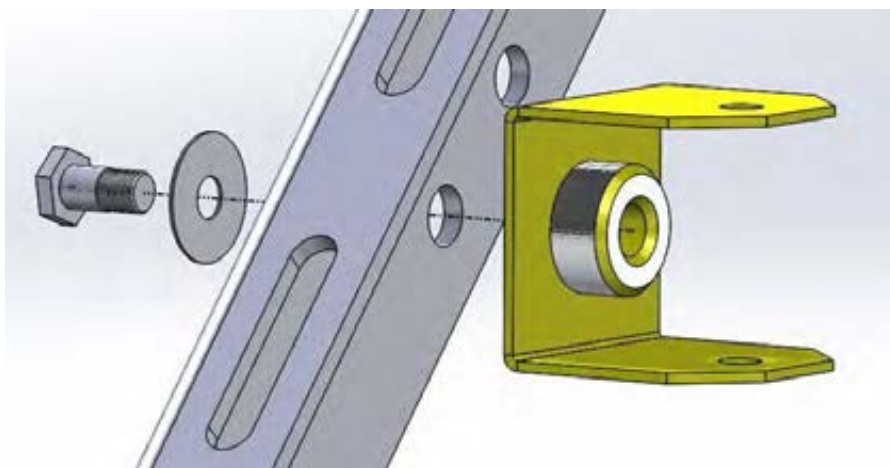

Figure 10. Exploded view of C-bracket installation inside of mounting rail

- To assemble the support rails, fit the smaller inner channel inside the larger outer channel so that the mounting holes on the flanges are opposite one another. Slide the channels to obtain the correct length determined by the panel tilt angle. Secure the support rails together at the desired length using a 1/4-20 x 3/4" hex bolt, lock washer, and flat washer on one side, and a flat washer and hex nut on the other side (2 per rail assembly) as shown in **Figure 11**.

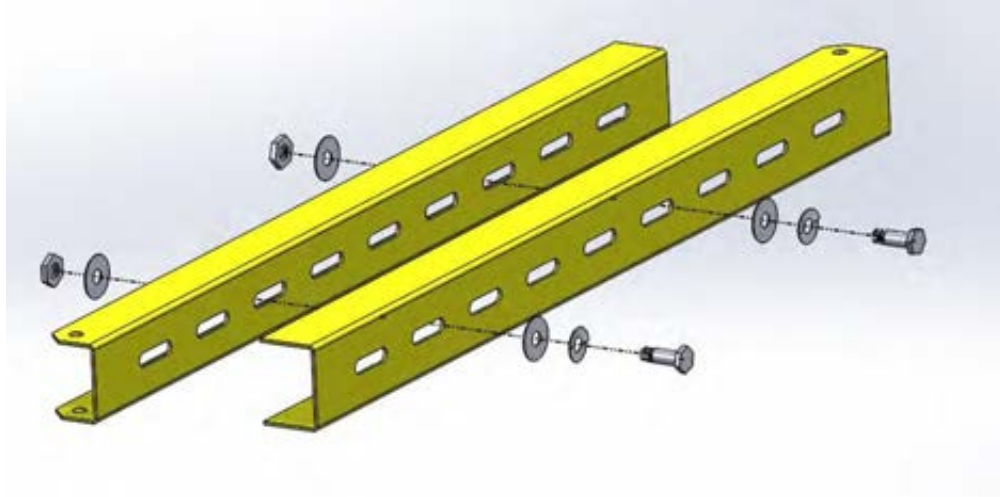

Figure 11. Support rail assembly



NOTE: For northern regions where a tilt angle of 65° or greater is required, it may be necessary to reduce the length of the support rails. If so, ensure that excess material is not discarded from the end with the mounting holes on the flanges. See **Figure 12**.



Figure 12. Discard section for larger tilt angles (65° and above)

- Use the assembled support rail to adjoin the mounting rails and the lower bucket bracket using a bolt, washers, and hex nut as shown in **Figure 13**. Mount the support rail assembly to the C-brackets using 1/4-20 x 1 5/8" hex bolt and to the lower bucket bracket using a 1/4-20 x 2" hex bolt. Tighten bolts to **7 ft-lbs**.



Figure 13. Secure support rails to panel mounting rail and lower bucket bracket

12. Once all adjustments are complete, ensure that all hardware is adequately tightened to specifications listed below.

Torque Table

Hardware Size	Torque Value
5/16"	12 ft-lbs
1/4"	7 ft-lbs

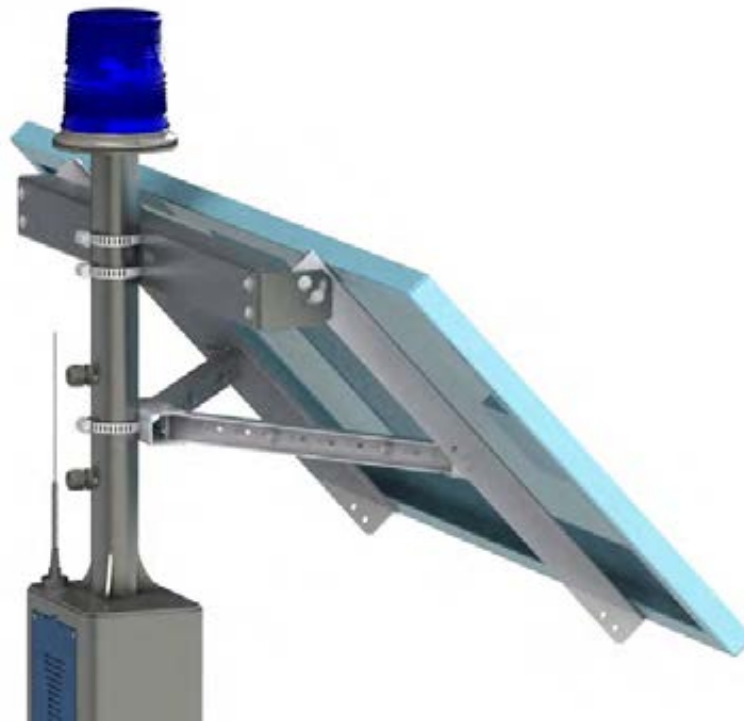

Figure 14. Assembled view of **SLR-80-84** (shown on **ETP-MTE-WP**)



Steps 13 – 18 are for solar kit SLR-120-84 only. For solar kit SLR-80-84 complete steps 9-12 and proceed to section V: Mechanical Installation

13. Bolt the remaining two clips to the lower bucket using the 5/16-18 x 3/4" bolt and flat washer on one end and a flat washer with a lock washer under the nut on the other end as shown in **Figure 15**.

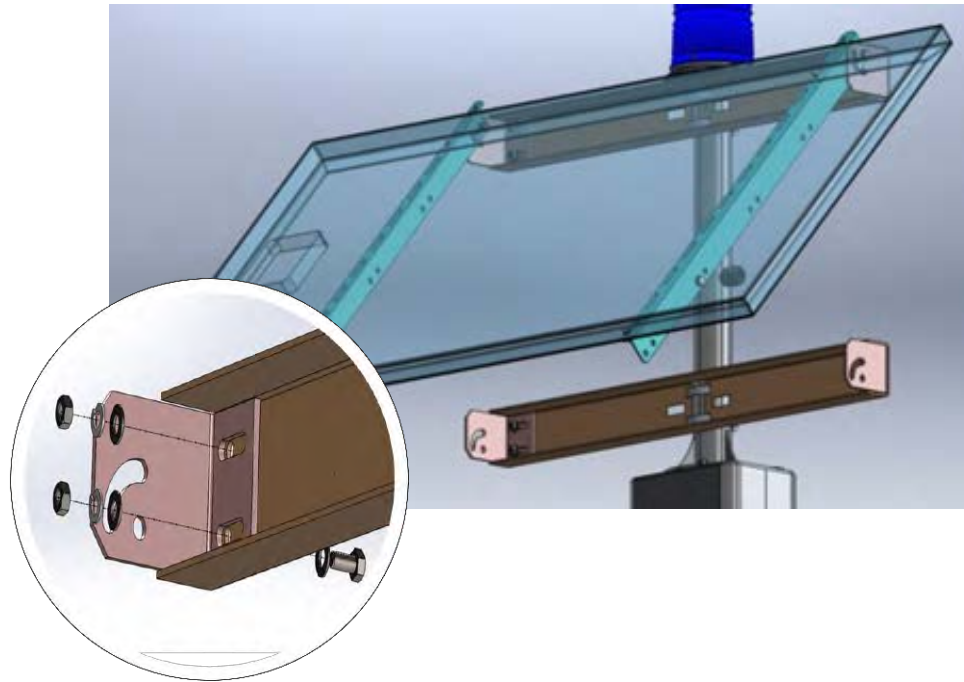

Figure 15. Installation of the clips to the lower bucket

14. The support rails will need to be customized based on the optimum tilt angle of the solar panel:
 - a. For optimum tilt angles of 40-45°, use the entire support rail as shown in **Figure 16**.

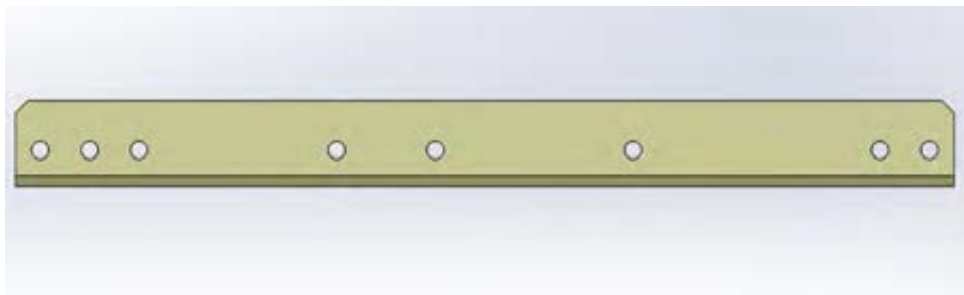

Figure 16. Support rail length for a solar panel with a tilt angle of 40-45°

- b. For optimum tilt angles of 50-60°, cut and discard the section 10 inches from the right as shown in **Figure 17**.

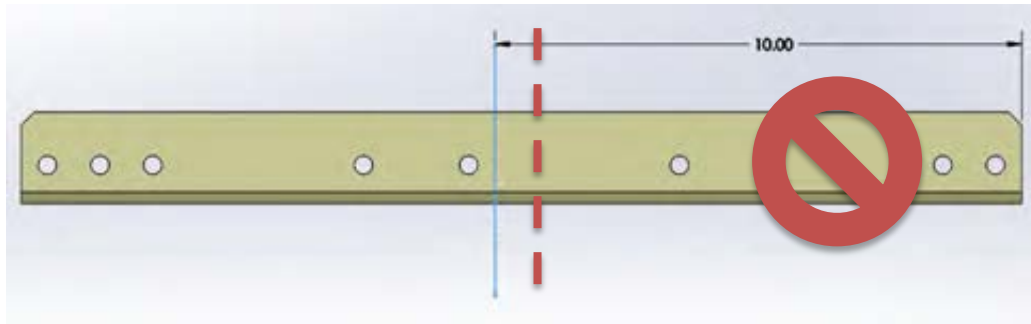

Figure 17. Support rail length for a solar panel with a tilt angle of 50-60°

- c. For an optimum tilt angle of 65°, cut and discard the section 6 inches from the right as shown in **Figure 18**.

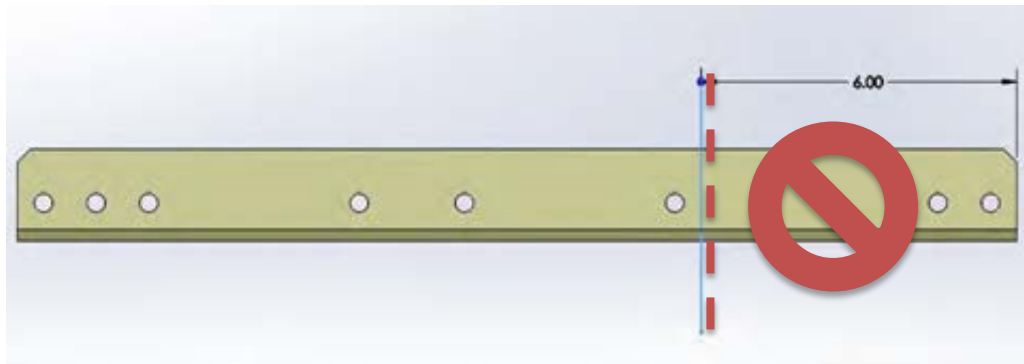

Figure 18. Support rail length for a PV module with a tilt angle of 65°



NOTE: For tilt angles ranging from 40-65°, two supporting rails are required out of the four provided. For angles of 35 degrees and less, the support rails may be extended using the other two rails (two support rails for each mounting rail).

15. Attach one end of the support rail to the lower bucket and attach the other end to the corresponding panel mounting rail using a 5/16 - 18 x 3/4" bolt, flat washers with a lock washer under the nut. Note the orientation of the rail depending on the panel tilt angle as shown in **Figures 19 - 23**. Tighten the bolts at both ends to **12 ft-lbs**.

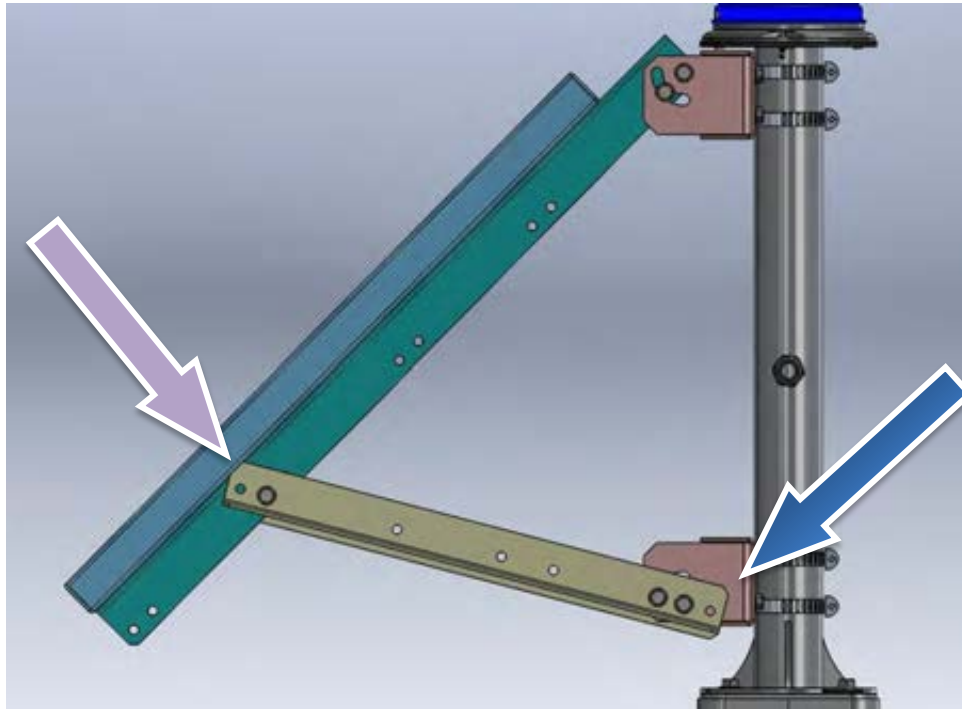

Figure 19. Support rail installation for a solar panel with a tilt angle of 45°

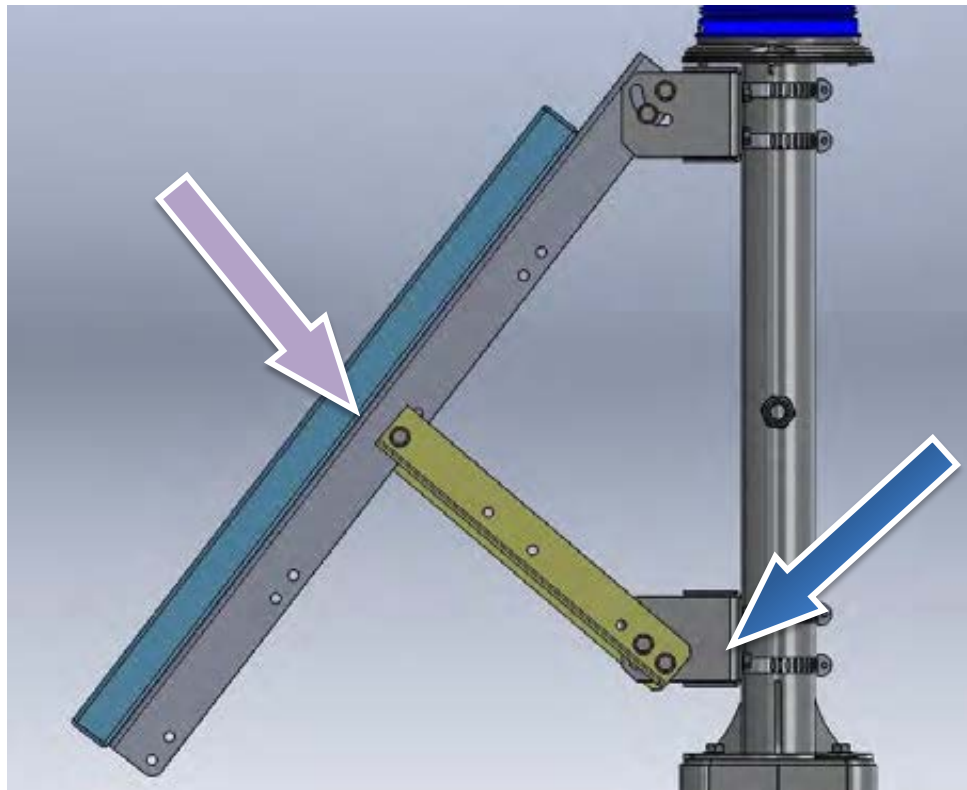

Figure 20. Support rail installation for a solar panel with a tilt angle of 50°

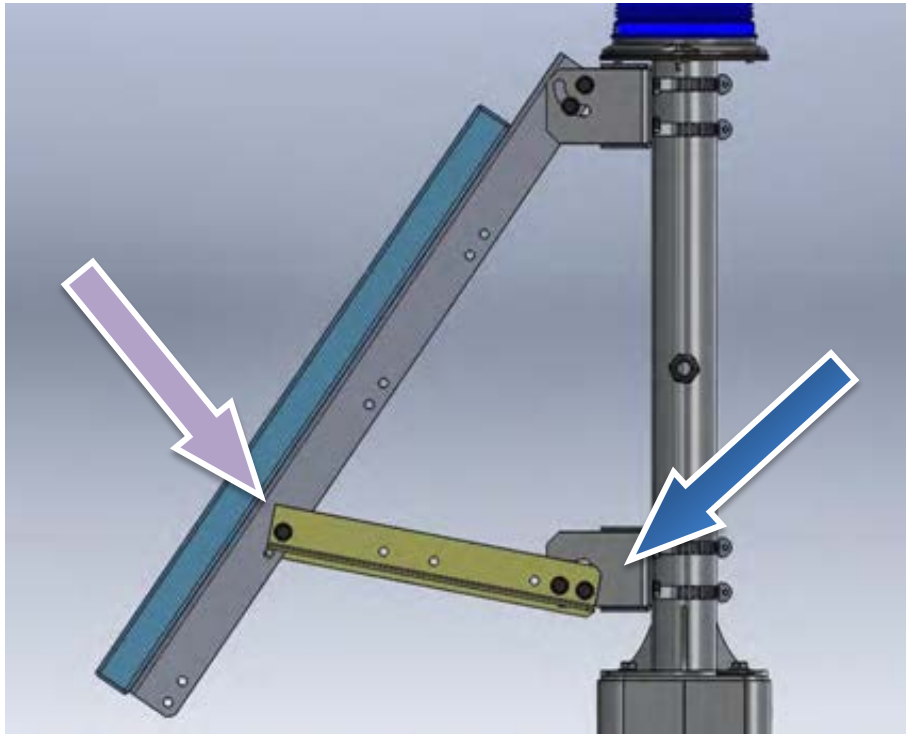

Figure 21. Support rail installation for a solar panel with a tilt angle of 55°

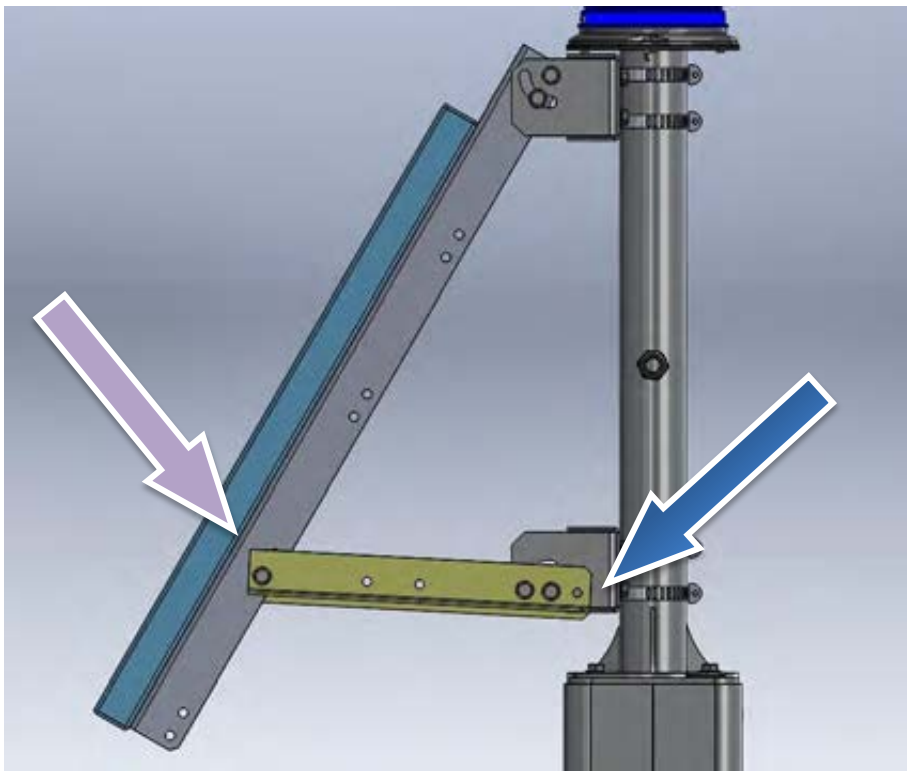

Figure 22. Support rail installation for a solar panel with a tilt angle of 60°

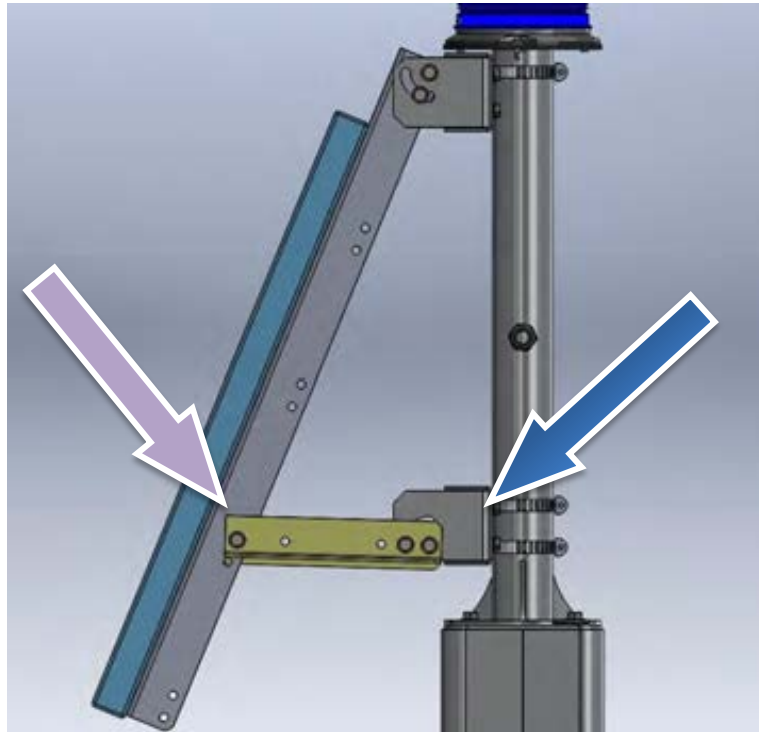

Figure 23. Support rail installation for a solar panel with a tilt angle of 65°

16. Once the adjustments are complete, tighten all 5/16" hardware to **12 ft-lbs** as shown in **Figure 24**.

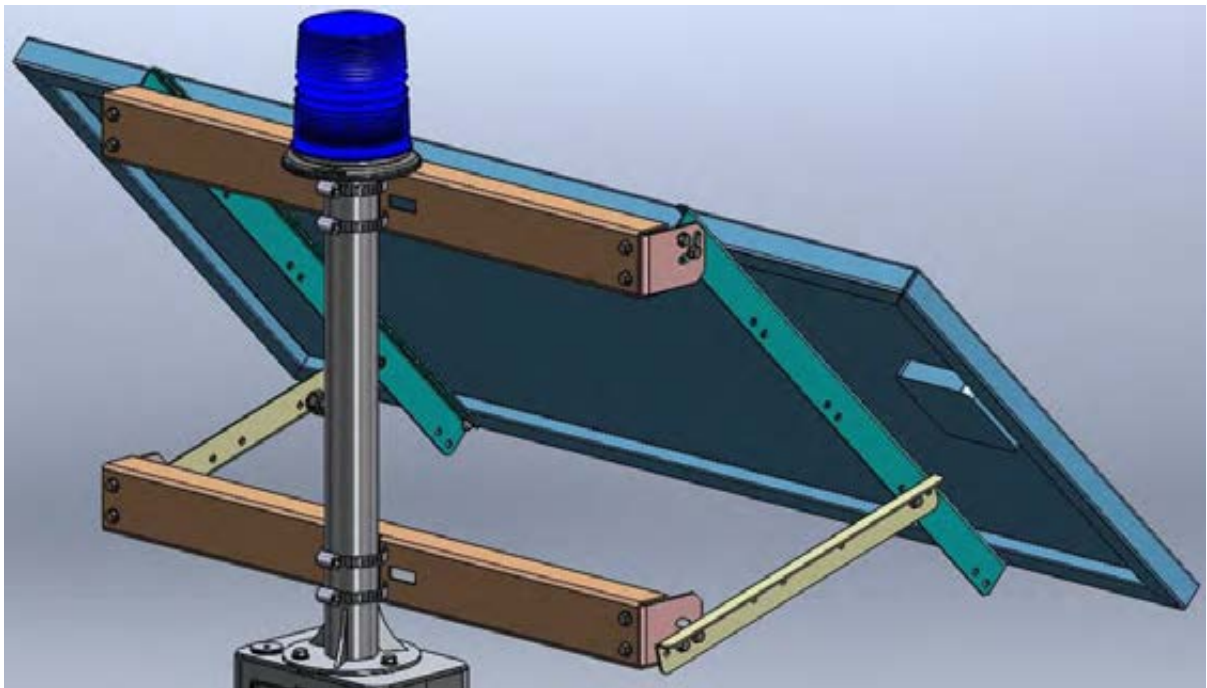

Figure 24. Assembled view of **SLR-120-84** (shown on **ETP-MTE-WP**)

V. Mechanical Installation

1. Install the LED light board above the phone opening. To install the polycarbonate light cover that protects the LED light assembly from the inside, peel the protective film off the light cover and fit it onto the studs inside the tower. Slide the LED board over the studs with the LEDs facing down. The built-in spacers will keep the LEDs from resting on the acrylic window. Tighten down using the enclosed #6 nuts. Be careful not to over-tighten to avoid cracking the circuit board.
2. If using an **ETP-CI** cellular device for wireless communication, install the antenna (using the respective installation instructions) on the enclosure mount for the **ETP-MTE-WP** or the pole mount for the **ETP-MT/R OP SOLAR** by uninstalling the hole-plug at the top of the mount. Run the power cable for the solar panel through the liquid tight cord grip on the side of the pole.
3. For **ETP-MTE-WP** (Refer to **Figure 25**),
 - a. Align the pole base to the center hole on top of the enclosure mount with a gasket in between. Rotate the pole along the vertical axis to minimize the cable travel distance from the PV module junction box and cord grip on the pole. Fasten the pole to the enclosure mount using the hex bolts and nylon washers on the outer end and a washer and nut on the inside.

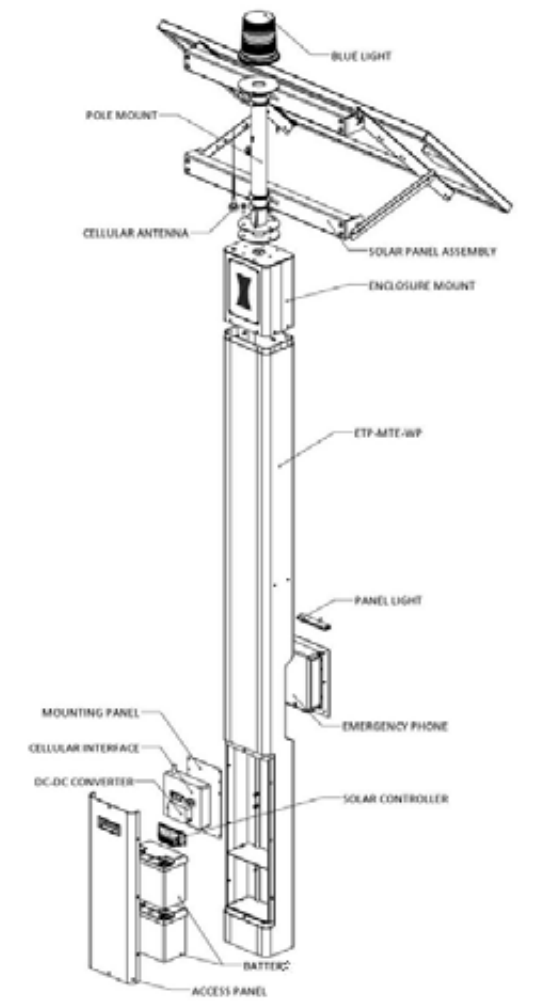

Figure 25. Exploded view of **ETP-MTE-WP** configuration

- b. Fasten the LED Blue Light to the base plate on top of the pole with three (3) tamperproof screws. Feed the power cord and control wires through the pole mount and the enclosure mount.
 - c. Feed the power cable and the antenna cable through the tower enclosure all the way to the bottom of the tower. Surplus cable is used to connect the two batteries.
 - d. Fasten the pole mount enclosure with the solar panel and antenna attached, to the tower
 - e. If installing an **ETP-CI** cellular device for wireless communication, install the cellular interface (if applicable) to the aluminum mounting panel by drilling two holes (for #10 screws) to align with the keyholes behind the device. Fasten a screw through each of the drilled holes using a hex nut in front and behind the panel. Mount the cellular device on to the heads of both screw fasteners.
 - f. Attach the DC-DC converter using the provided dual lock fasteners at a convenient location either on to the tower internal sidewall or on the cellular device itself.
 - g. Skip to step 5.
4. For **ETP-MT/R OP SOLAR** (Refer to **Figure 26**),

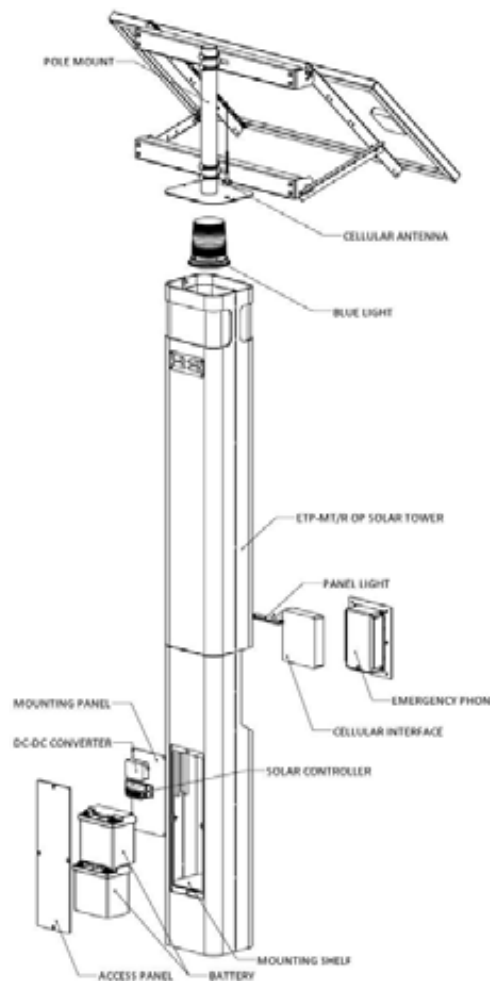

Figure 26. Exploded view of **ETP-MT/R OP SOLAR** configuration

- a. Fasten the LED Blue Light to the base plate with three (3) tamperproof screws inside the Blue Light housing at the top of the tower. Feed the power cord and control wires through the tower enclosure.
 - b. Feed the power cable and the antenna cable through the two wire routing clips and into the hole beneath the clips to run those cables into the tower enclosure all the way to the bottom. Extra cable is used to connect the two batteries.
 - c. Fasten the pole mount with the solar panel and antenna attached, to the tower enclosure using the tamper-resistant fasteners provided.
 - d. Install the cellular interface (if applicable) to the two studs behind the phone-mounting panel.
 - e. Mount the DC-DC Converter to the mounting panel behind the bottom access panel.
5. Install the solar controller using the included fasteners (four pan-head screws, hex nuts and washers) to the mounting panel. This is the where most of the wiring will be connected.

VI. Electrical Installation

1. Connect the solar panel power cable to the junction box behind the solar panel as shown in **Figure 27**. Connect the red cable to the positive terminal and the black cable to the negative terminal.
 - a. To open the junction box, use a screwdriver with a 9/64" wide flat head. Insert the screwdriver into the marked opening lug. Gently unlock the lug and release the lid. Do not pull the lid out at once.
 - b. Open cable gland nut, if not already factory-provided.
 - c. Strip 0.44" of insulation from cable. Use 9/64" flat-head screwdriver to press and hold down the terminal clamp. Push cable through the cable gland and lead it to the terminal clamp. Pay attention to the polarity. Repeat with the second cable. Ensure the correct plug-in depth of 2.0 in for cable to junction box.
 - d. Removal of the tool causes a clamping connection. Check by pulling the cable. After proper installation the top end of cable spring is deeper compared to the middle idle cable spring.
 - e. After covering the box with the lid push the lid over the entire perimeter.
 - f. Tighten cable gland to **11.5 – 13.3 ft-lbs** to ensure IP65 protection and proper tightening of the cable.

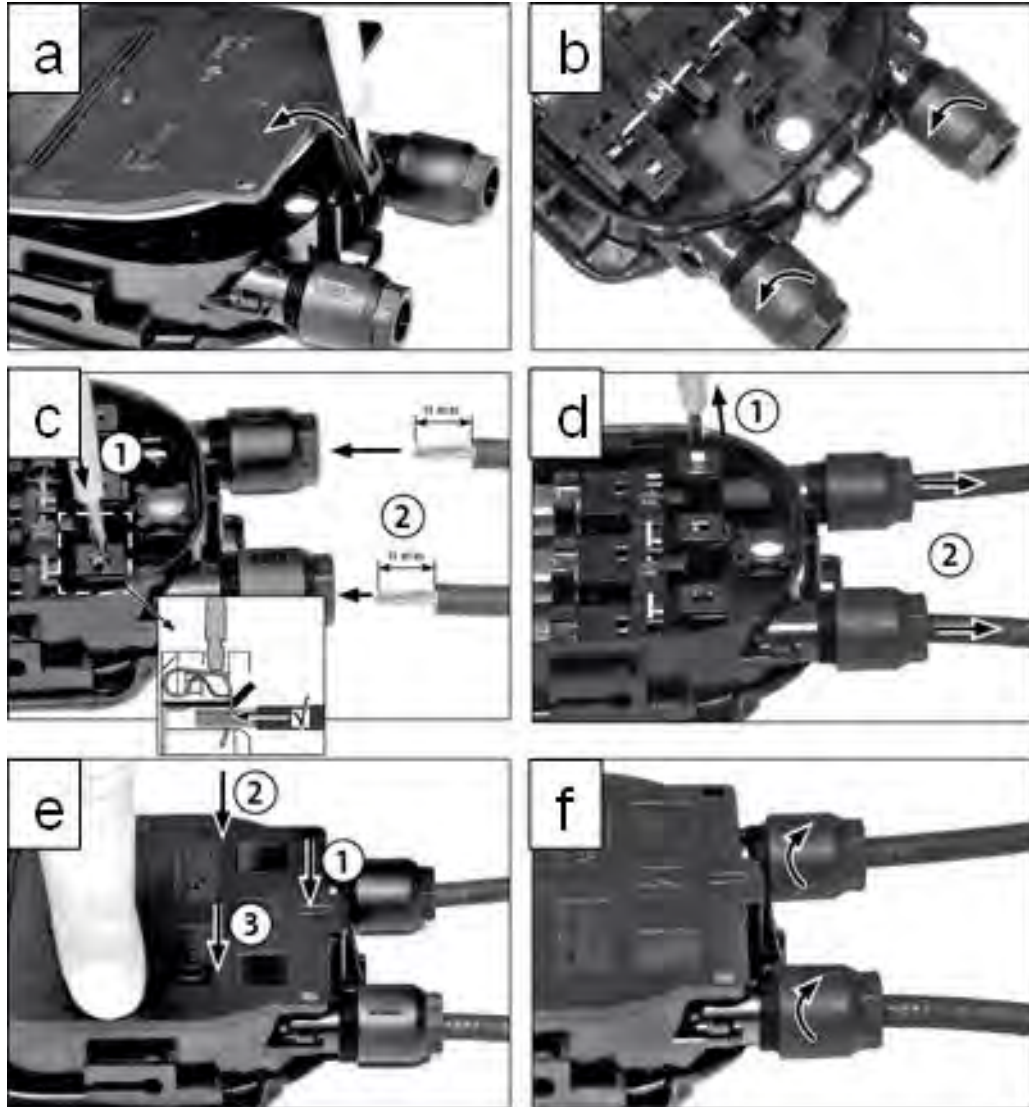

Figure 27. Connecting the power cable to the solar panel junction box

2. Connect the power cable from the solar panel to the “SOLAR” terminals on the solar controller. **Do not discard excess wire.** Refer to the wiring diagram as shown in **Figure 28**.
3. Connect the batteries in parallel to the “BATTERY” terminals on the solar controller using the excess power cable. Crimp-on connectors are included for the batteries. Ensure that the shunt on the solar controller is installed correctly for the battery type. Refer to the wiring diagram as shown in **Figure 28**.

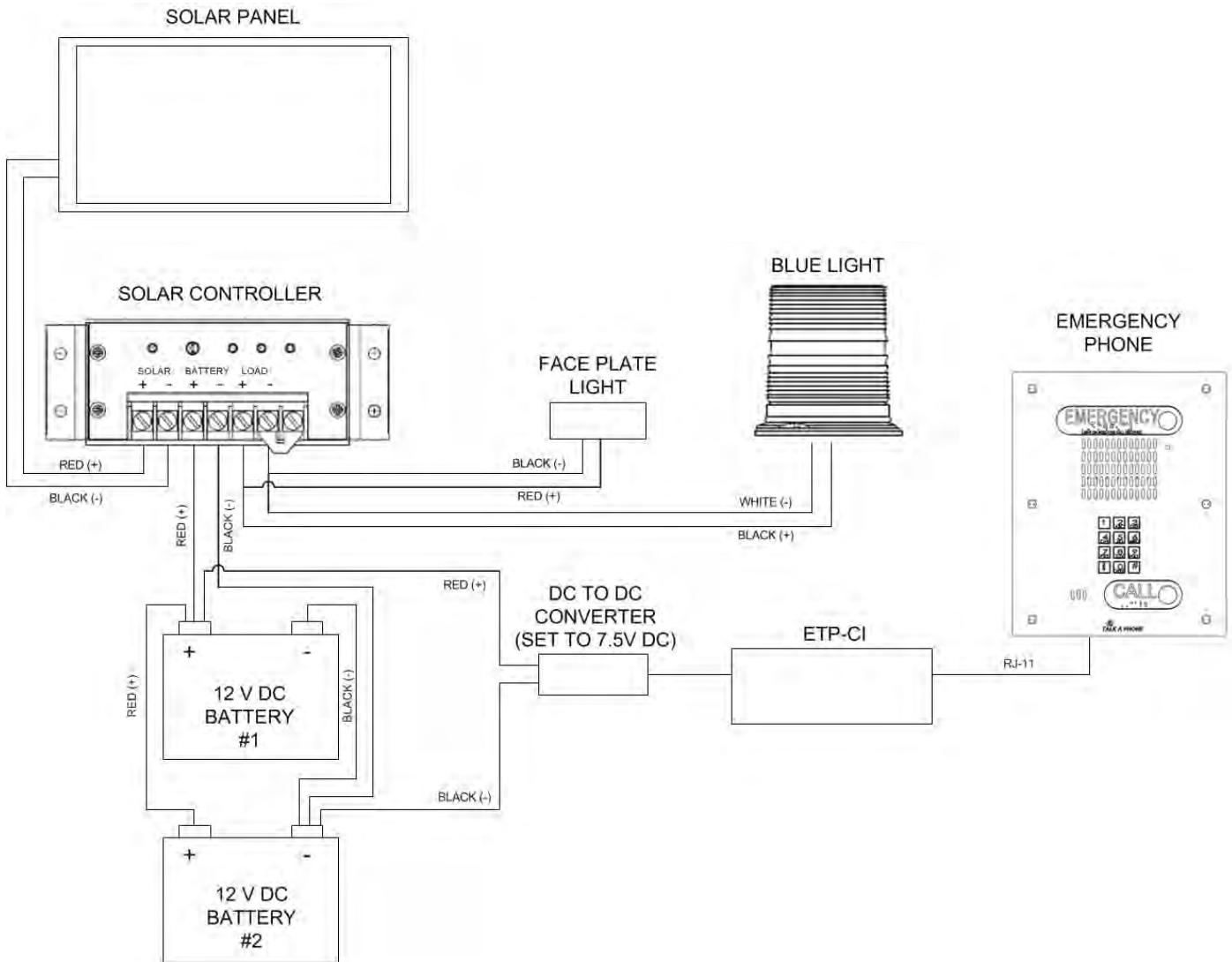

Figure 28. Solar system wiring schematic

- The LED Blue Light (as shown in **Figure 29**) and LED Panel Light power wires should be connected to the "LOAD" terminals on the controller.

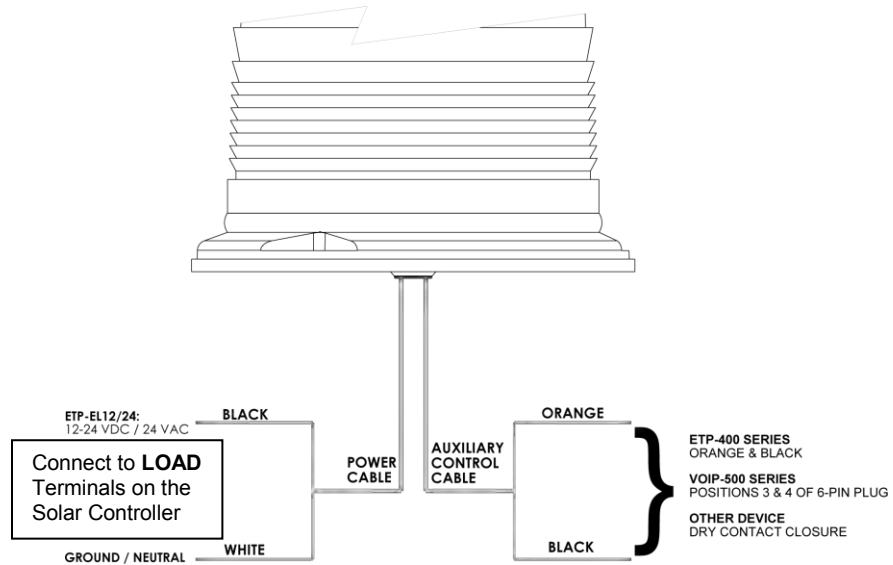

Figure 29. Electrical Connections to the ETP-EL 12/24 LED Blue Light



NOTE: TOWER PTS SOLAR is shipped with ETP-EL12/24 Series Blue Light in Low Power Mode instead of default power mode as shown in **Figure 30**. For Solar applications the Blue Light must operate in Low Power Mode.

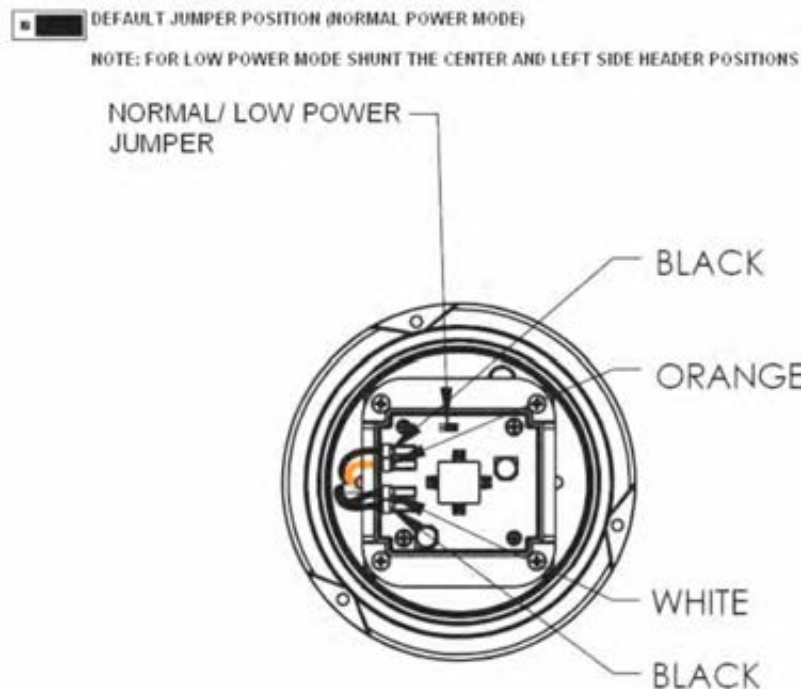

Figure 30. Normal / Low power mode jumper inside LED Blue Light

5. If installing an ETP-CI, connect the antenna cable to the cellular interface. Cellular interfaces should be powered by the included DC/DC converter, which has battery ring terminals pre-connected. **The cellular interface (through the DC/DC converter) should be connected directly to the battery.** The DC-DC converter should be set to 7.5 VDC for the cellular interface device.



NOTE: If the battery voltage drops below a set threshold, the solar controller will shut off power to the “LOAD” terminals. By connecting the emergency communication equipment directly to the battery, emergency calls can still be placed for a small period of time after the lighting disconnects.



NOTE: Excessive drainage will damage batteries. If lights disconnect due to low voltage, batteries must be replaced promptly to ensure correct system operation during night time hours.

6. Install the shelves and batteries in the tower’s rear lower compartment as shown in **Figures 25 & 26**. Make all remaining connections, including connecting the batteries in parallel with the provided connector cable. *Refer to **Figure 28***



NOTE: IT IS ESSENTIAL THAT THE BATTERIES ARE CONNECTED IN PARALLEL AND NOT IN SERIES OR SYSTEM DAMAGE WILL OCCUR.

7. When using the LED Blue Light with **ETP-400** Series Emergency Phones, connect the orange and black auxiliary control cable pair of the Blue Light to the orange and black wires of the Emergency Phone. Plug the RJ11 connector from the emergency phone into the cellular interface.
8. Attach the Emergency Phone to the tower with six (6) 10-24 oval head tamperproof screws.



Refer to the Emergency Phone Manual and ETP-CI Instructions for information regarding the programming of your phone.

9. A single-gang electrical box with a grounding stud is provided inside the enclosure and should be used for grounding purposes only.
10. Re-attach the access panel cover(s).
11. Refer to **Figure 31** and **32** for a fully assembled view of the **ETP-MTE-WP** and **ETP-MT/R OP SOLAR**.



To ensure proper grounding of all electrical components, the tower enclosure should be effectively earth grounded from the grounding stud with 6 AWG or better insulated, stranded copper wire to the metallic power service raceway (conduit) or an 8' or longer corrosion-resistant ground spike.

Use effective drip loops on all wiring connections.

All wiring should comply with local, regional and national codes.

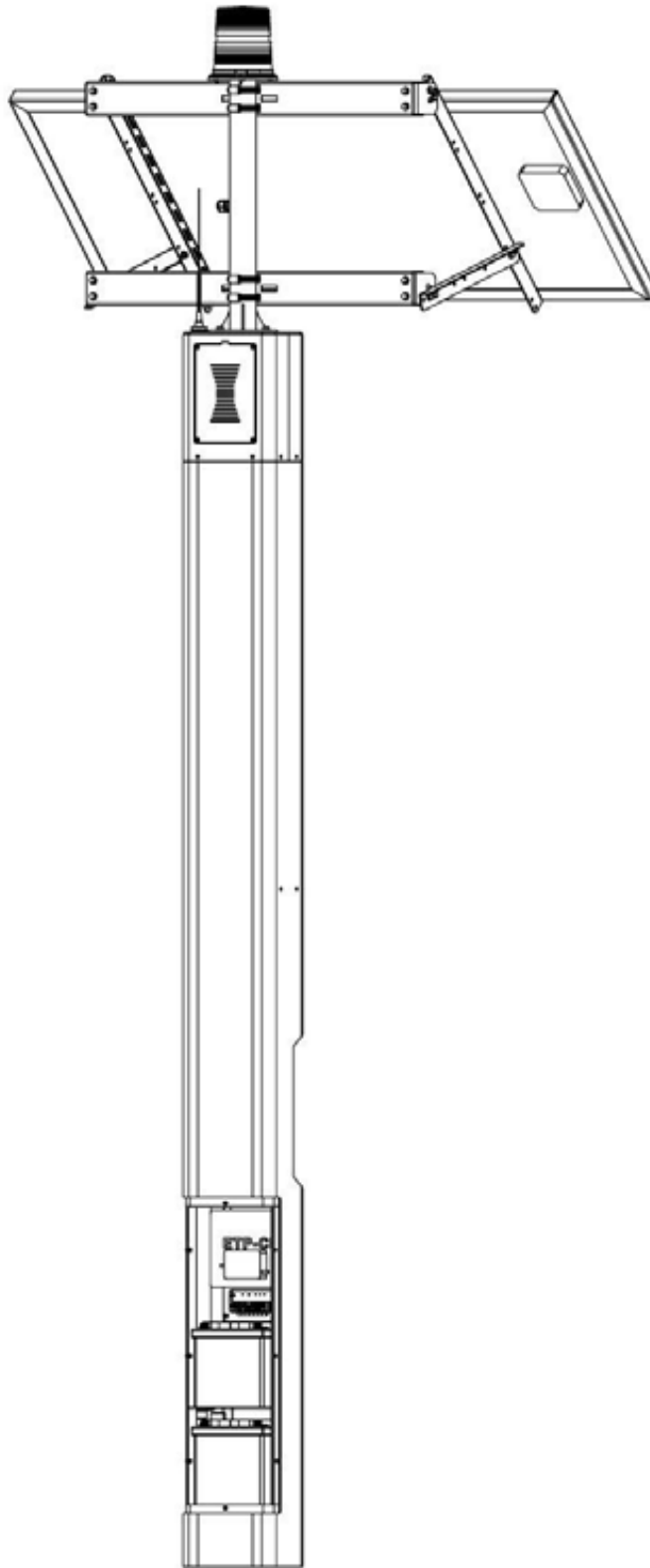

Figure 31. ETP-MTE-WP with access panel removed, assembly overview (SLR-120-84)

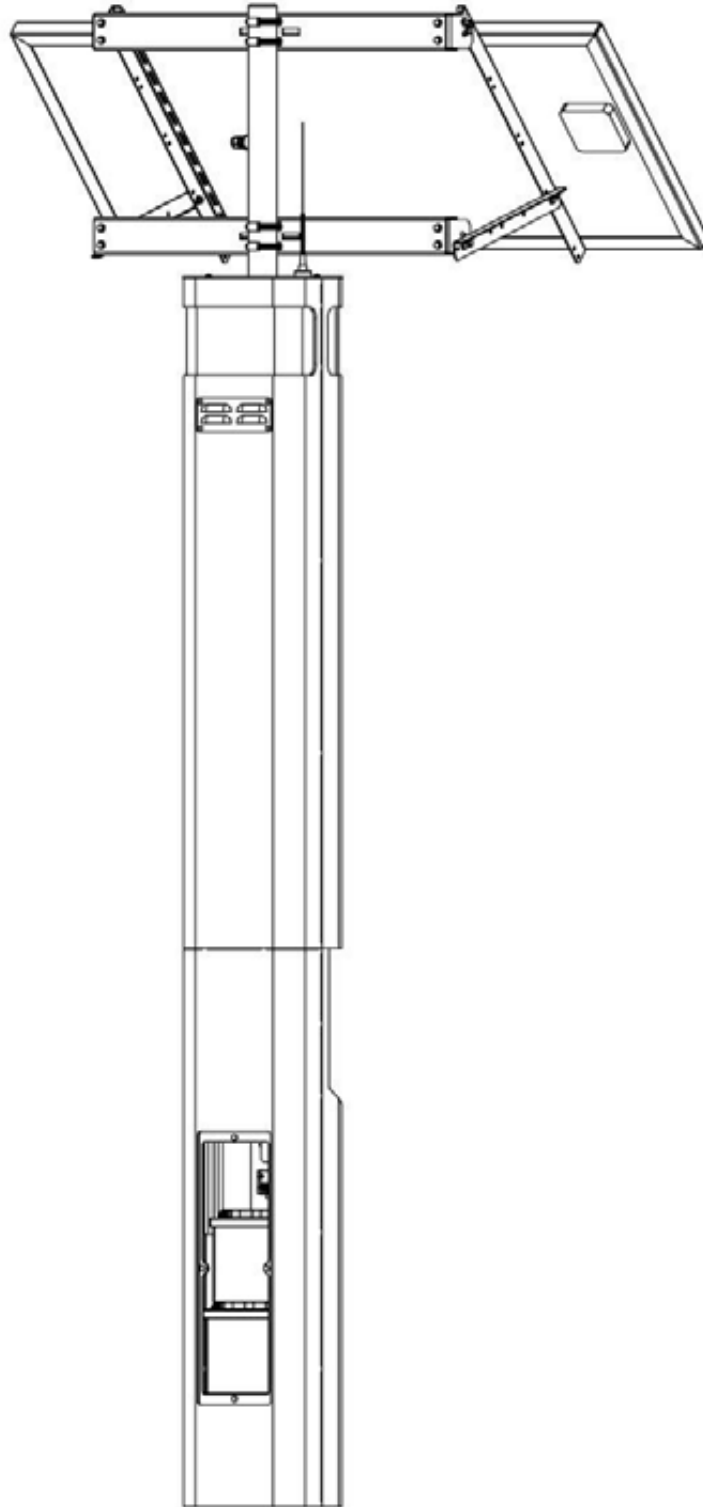

Figure 32. ETP-MT/R OP SOLAR with access panel removed, assembly overview (SLR-120-84)

Appendix A: Solar Panel Optimum Tilt Angle Table Year-Round Non-Adjustable Installation

<u>ALABAMA</u>		Mandalay-CA	50	Tallahassee-FL	50
Birmingham-AL	55	Moorpark-CA	55	Tampa-FL	40
Mobile-AL	55	Mount Shasta-CA	65	West Palm Beach-FL	35
Montgomery-AL	55	Needles-CA	55	<u>GEORGIA</u>	
<u>ALASKA</u>		Oakland-CA	60	Atlanta-GA	55
Adak-AK	70	Palm Springs-CA	55	Augusta-GA	55
Annette-AK	75	Pardee-CA	55	Macon-GA	55
Bethel-AK	80	Point Mugu-CA	50	Savannah-GA	55
Gulkana-AK	80	Ramona-CA	55	<u>HAWAII</u>	
Homer-AK	80	Red Bluff-CA	65	Barbers Point-HI	35
Juneau-AK	75	Redwood City-CA	60	Hilo-HI	35
King Salmon-AK	80	Rialto-CA	55	Honolulu-HI	40
Kodiak-AK	75	Richmond-CA	60	Lihue-HI	40
Matanuska-AK	80	Riverside-CA	55	<u>IDAHO</u>	
McGrain-AK	80	Sacramento-CA	60	Boise-ID	65
Summit-AK	80	San Diego-CA	50	Kimberly-ID	65
Yakutat-AK	75	San Francisco-CA	60	Lewiston-ID	65
<u>ARIZONA</u>		San Luis Dam-CA	60	Pocatello-ID	65
Phoenix-AZ	55	San Rafael-CA	60	<u>ILLINOIS</u>	
Prescott-AZ	50	Santa Maria-CA	60	Chicago-IL	65
Tucson-AZ	50	Sun Valley-CA	55	Moline-IL	65
Winslow-AZ	50	Sunnyvale-CA	60	Springfield-IL	65
Yuma-AZ	50	Victorville-CA	60	<u>INDIANA</u>	
<u>ARKANSAS</u>		Villa Park-CA	55	Evansville-IN	60
Fort Smith-AR	60	Visalia-CA	60	Fort Wayne-IN	65
Little Rock-AR	60	Walnut-CA	60	Indianapolis-IN	60
<u>CALIFORNIA</u>		Warm Sprgs Dam-CA	60	South Bend-IN	60
Alpine-CA	55	Yucca Valley-CA	55	<u>IOWA</u>	
Arcata-CA	65	<u>COLORADO</u>		Burlington-IA	65
Arrowhead-CA	55	Akron-CO	55	Des Moines-IA	65
Bakersfield-CA	60	Alamosa-CO	50	Mason City-IA	65
Blythe-CA	50	Boulder-CO	60	Sioux City-IA	65
Butler Valley Ranch-CA	65	Colorado Springs-CO	55	<u>KANSAS</u>	
Carlsbad-CA	55	Denver-CO	60	Dodge City-KS	60
Carris Plain-CA	60	Eagle-CO	65	Goodland-KS	65
Chula Vista-CA	55	Fort Collins-CO	55	Topeka-KS	65
Daggett-CA	60	Grand Junction-CO	65	Wichita-KS	60
Davis-CA	60	Pueblo-CO	55	<u>KENTUCKY</u>	
El Cajon-CA	55	<u>CONNECTICUT</u>		Lexington-KY	60
El Centro-CA	45	Hartford-CT	60	Louisville-KY	60
El Segundo-CA	55	<u>DELAWARE</u>		<u>LOUISIANA</u>	
El Toro-CA	55	Wilmington-DE	65	Baton Rouge-LA	55
Escondido-CA	55	<u>DISTRICT OF COL.</u>		Lake Charles-LA	50
Fresno-CA	60	Washington, D.C.	60	New Orleans-LA	55
Huntington Beach-CA	55	<u>FLORIDA</u>		Shreveport-LA	55
Inyokem-CA	60	Apalachicola-FL	55	<u>MAINE</u>	
Jolon-CA	60	Daytona Beach-FL	45	Bangor-ME	65
Lancaster-CA	60	Jacksonville-FL	50	Caribou-ME	65
Long Beach-CA	55	Miami-FL	35	Portland-ME	65
Los Angeles-CA	55	Orlando-FL	40		

<u>MARYLAND</u>		<u>NEW HAMPSHIRE</u>		Medford-OR	65	Waco-TX	55
Baltimore-MD	60	Concorde-NH	65	North Bend-OR	65	Wichita Falls-TX	55
Patuxent River-MD	60	<u>NEW JERSEY</u>		Pendleton-OR	65	<u>UTAH</u>	
<u>MASSACHUSETTS</u>		Lakehurst-NJ	65	Portland-OR	65	Bryce Canyon-UT	60
Blue Hill-MA	60	Newark-NJ	65	Redmond-OR	65	Cedar City-UT	65
Boston-MA	65	<u>NEW MEXICO</u>		Salem-OR	65	Salt Lake City-UT	65
<u>MICHIGAN</u>		Albuquerque-NM	55	Whitehorse Ranch-OR	65	<u>VERMONT</u>	
Alpena-MI	65	Clayton-NM	50	<u>PENNSYLVANIA</u>		Burlington-VT	65
Detroit-MI	65	Farmington-NM	60	Allentown-PA	65	<u>VIRGINIA</u>	
Flint-MI	60	Roswell-NM	50	Erie-PA	60	Norfolk-VA	60
Grand Rapids-MI	60	Truth or Conseq.-NM	45	Harrisburg-PA	65	Richmond-VA	60
Houghton-MI	65	Tucumcari-NM	50	Philadelphia-PA	65	Roanoke-VA	60
Sault St. Marie-MI	65	Zuni-NM	50	Pittsburgh-PA	60	<u>WASHINGTON</u>	
Traverse City-MI	65	<u>NEW YORK</u>		Wilkes-Barre-PA	65	Olympia-WA	65
<u>MINNESOTA</u>		Albany-NY	65	<u>RHODE ISLAND</u>		Seattle-WA	65
Duluth-MN	65	Binghamton-NY	65	Providence-RI	65	Spokane-WA	70
Interna'l Falls-MN	70	Buffalo-NY	65	<u>SOUTH CAROLINA</u>		Whidbey Island-WA	70
Minn-St. Paul-MN	65	Massena-NY	65	Charleston-SC	55	Yakima-WA	65
Rochester-MN	65	New York City-NY	65	Columbia-SC	55	<u>WEST VIRGINIA</u>	
<u>MISSISSIPPI</u>		Rochester-NY	60	Greenville-SC	60	Charleston-WV	60
Jackson-MS	55	Syracuse-NY	60	<u>SOUTH DAKOTA</u>		Huntington-WV	60
Meridian-MS	55	<u>NORTH CAROLINA</u>		Huron-SD	65	<u>WISCONSIN</u>	
<u>MISSOURI</u>		Asheville-NC	60	Pierre-SD	70	Eau Claire-WI	65
Columbia-MO	60	Cape Hatteras-NC	60	Rapid City-SD	65	Green Bay-WI	65
Kansas City-MO	65	Charlotte-NC	60	Sioux Falls-SD	65	La Crosse-WI	65
Springfield-MO	60	Cherry Point-NC	55	<u>TENNESSEE</u>		Madison-WI	65
St. Louis-MO	60	Greensboro-NC	60	Chattanooga-TN	55	Milwaukee-WI	65
<u>MONTANA</u>		Raleigh-NC	60	Knoxville-TN	60	<u>WYOMING</u>	
Billings-MT	70	<u>NORTH DAKOTA</u>		Memphis-TN	60	Casper-WY	70
Cut Bank-MT	70	Bismarck-ND	70	Nashville-TN	60	Cheyenne-WY	60
Dillon-MT	70	Fargo-ND	70	<u>TEXAS</u>		Lander-WY	65
Glasgow-MT	70	Minot-ND	70	Abilene-TX	55	Rock Springs-WY	65
Great Falls-MT	70	<u>OHIO</u>		Amarillo-TX	50	Sheridan-WY	70
Helena-MT	70	Akron-OH	60	Austin-TX	50		
Lewiston-MT	70	Cincinnati-OH	60	Brownsville-TX	50		
Miles City-MT	70	Cleveland-OH	60	Corpus Christi-TX	50		
Missoula-MT	65	Columbus-OH	60	Dallas-TX	55		
<u>NEBRASKA</u>		Dayton-OH	60	Del Rio-TX	45		
Grand Island-NE	65	Toledo-OH	65	El Paso-TX	50		
North Omaha-NE	65	Youngstown-OH	60	Fort Worth-TX	55		
North Platte-NE	65	<u>OKLAHOMA</u>		Houston-TX	55		
Scottsbluff-NE	65	Oklahoma City-OK	60	Kingsville-TX	50		
<u>NEVADA</u>		Tulsa-OK	60	Laredo-TX	50		
Elko-NV	65	<u>OREGON</u>		Lubbock-TX	50		
Ely-NV	65	Astoria-OR	65	Lufkin-TX	55		
Las Vegas-NV	55	Bend-OR	70	Midland-TX	50		
Lovelock-NV	65	Burns-OR	65	Port Arthur-TX	55		
Reno-NV	65	Eugene-OR	65	San Angelo-TX	50		
Tonopah-NV	60	Hermiston-OR	65	San Antonio-TX	55		