

DRV602EVM2

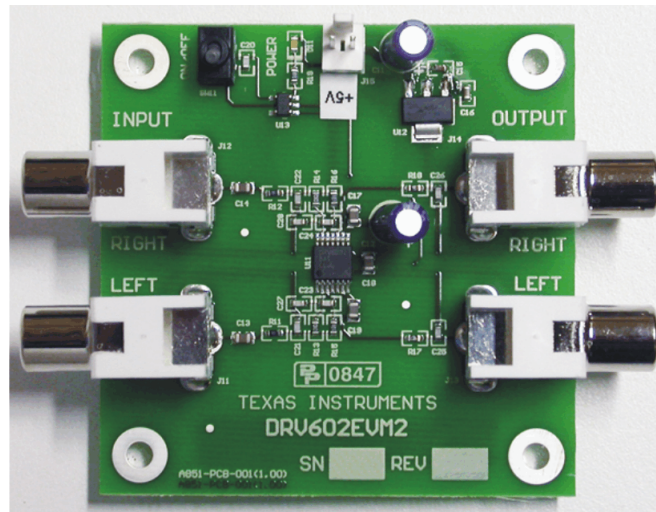

DRV602EVM2

This user's guide describes the operation of the DRV602 evaluation module. This document also provides measurement data and design information including a schematic, bill of materials, and printed circuit board (PCB) layout drawings.

Contents

1	Overview	2
2	Quick Setup.....	3
3	On/Off Sequence	4
4	Component Selection	4
5	Layout Recommendations.....	7
6	DRV602EVM2 Performance	7
7	Related Documentation from Texas Instruments	12
8	Design Documentation	12

List of Figures

1	DRV602EVM2 Functional Block Diagram	3
2	Power-Up/-Down Sequence.....	4
3	Second-Order, Active Low-Pass Filter	5
4	Differential Input, Second-Order Active Low-Pass Filter	6
5	THD+N versus Voltage	8
6	THD+N versus Frequency.....	9
7	FFT Spectrum with -60-dBFS Tone	9
8	Channel Separation.....	10
9	Frequency Response	10
10	Pop/Click (Enable)	11

DirectPath is a trademark of Texas Instruments.
Blu-ray Disc is a trademark of Blu-ray Disc Association.
All other trademarks are the property of their respective owners.

11	Pop/Click (Disable)	11
12	DRV602EVM2 Schematic: DRV602	12
13	DRV602EVM2 Schematic: On/Off and Regulator	12
14	DRV602EVM2 PCB Component Placement.....	15
15	DRV602EVM2 PCB Top Layer.....	16
16	DRV602EVM2 PCB Bottom Layer	16

List of Tables

1	Key Parameters	3
2	Recommended Supply Voltage	4
3	DRV602EVM2 Filter Specifications	5
4	General Test Conditions	7
5	Electrical Data	7
6	Audio Performance Analog Input	8
7	Physical Specifications.....	8
8	Related Documentation.....	12
9	Bill of Materials	13
10	PCB Specifications.....	14

1 Overview

The DRV602EVM2 customer evaluation module (EVM) demonstrates the capabilities and operation of the [DRV602](#) integrated circuit from Texas Instruments.

The DRV602 is a 2- V_{RMS} pop-free stereo line driver designed to allow removal of the output dc-blocking capacitors in audio applications to reduce component count and overall cost. The device is ideal for single-supply electronics where size and cost are critical design parameters.

Designed using TI's patented DirectPath™ technology, the DRV602 is able to drive 2 V_{RMS} into a 2.5-k Ω load with 3.3-V supply voltage. The device has differential inputs and uses external gain-setting resistors that support a gain range of ± 1 V/V to ± 10 V/V, and line outputs that have ± 8 kV IEC electrostatic discharge (ESD) protection. The DRV602 also has built-in shutdown control for pop-free on/off control.

Using the DRV602 in audio product applications can reduce component counts considerably compared to traditional methods of generating a 2- V_{RMS} output. The DRV602 does not require a power supply greater than 3.3 V to generate its 5.6- V_{PP} output, nor does it require a split-rail power supply. The DRV602 integrates its own charge pump to generate a negative supply rail that provides a clean, pop-free, ground-biased 2- V_{RMS} output. The DRV602 is available in a 14-pin TSSOP package.

This EVM is configured with two RCA phono input connectors for analog input; the output signal is available on two RCA phono connectors. The power supply is connected via a two-pin, 2.54-mm header.

This evaluation board is designed for testing applications such as set-top boxes, LCD/PDP TVs, Blu-ray Disc™ DVD players, DVD mini-component systems, home theater-in-a-box (HTIB) systems, or soundcards.

This document presents EVM specifications, audio performance measurements graphs, and design documentation that includes complete circuit descriptions, schematic diagrams, a parts list, and PCB layout design. Gerber (layout) files are available from the TI web site at www.ti.com.

Throughout this document, the abbreviation *EVM* and the term *evaluation module* are synonymous with the DRV602EVM2.

1.1 DRV602EVM2 Features

The DRV602EVM2 has these features:

- Two-channel evaluation module (double-sided, plated-through PCB layout)
- $2\text{-}V_{\text{RMS}}$ line output
- No output capacitor required
- Shutdown button

Figure 1 illustrates the functional diagram for the EVM. Table 1 summarizes the key parameters.

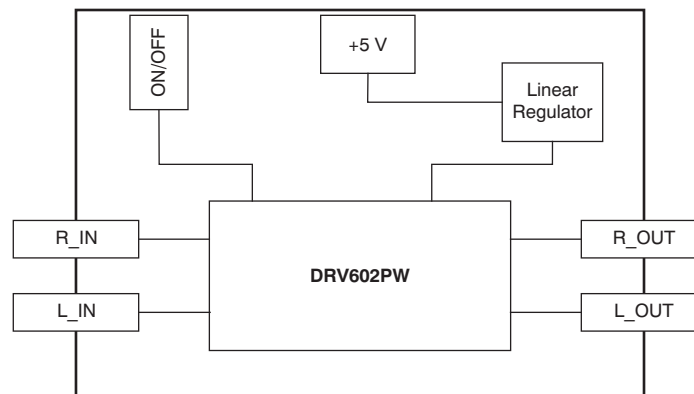

Figure 1. DRV602EVM2 Functional Block Diagram

Table 1. Key Parameters

Key Parameters	Specification/Unit
Supply Voltage	5 V
Number of Channels	Two
Load Impedance	2.5 k Ω (min)
Output Voltage	$> 2 V_{\text{RMS}}$
Dynamic Range	$> 102 \text{ dB}$

2 Quick Setup

This section describes the DRV602EVM2 board with regard to the power supply and system interfaces. It provides information about handling and unpacking the DRV602EVM2, absolute operating conditions, and a description of the factory default switch and jumper configurations.

The following subsections provide a step-by-step guide to configuring the DRV602EVM2 for device evaluation.

2.1 Electrostatic Discharge Notice

CAUTION

Many of the components on the DRV602EVM2 are susceptible to damage by electrostatic discharge (ESD). Customers are advised to observe proper ESD handling precautions when unpacking and handling the EVM, including the use of a grounded wrist strap at an approved ESD workstation.

Failure to observe proper ESD handling procedures may result in damage to EVM components.

2.2 Unpacking the EVM

Upon opening the DRV602EVM2 package, ensure that the following items are included:

- One DRV602EVM2 evaluation board, including:
 - One DRV602PW device

If either item is missing, please contact the Texas Instruments Product Information Center nearest you to inquire about a replacement.

2.3 Power-Supply Setup

A single power supply is required to power up the EVM. The power supply is connected to the EVM board using a two-pin, 2,54-mm header (J10). [Table 2](#) lists the recommended supply voltage.

Table 2. Recommended Supply Voltage

Description	Voltage Limitations	Current Requirement	Cable
Power supply	5 V	0.10 A	—

CAUTION

Applying voltages above the limitations given in [Table 2](#) may cause permanent damage to your hardware.

3 On/Off Sequence

For minimum click and pop interference during device power on and power off, the DRV602 Enable pin (pin 5) should be held low, primarily because of pre-charging of the ac-coupled input capacitors. The preferred power-up/-down sequence is shown in [Figure 2](#).

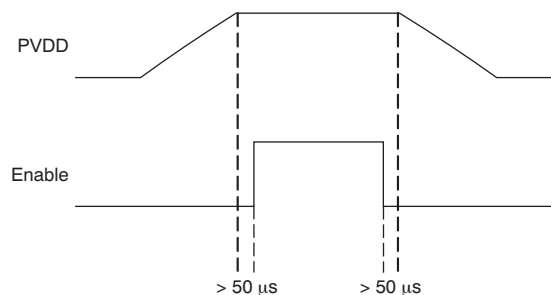

Figure 2. Power-Up/-Down Sequence

This sequence is ensured by the onboard supply monitor, U13.

4 Component Selection

4.1 Charge Pump

The charge pump flying capacitor, C18, serves to transfer charge during the generation of the negative supply voltage. The PVSS capacitor must be at least equal to the charge pump capacitor in order to allow a maximum charge transfer. Low equivalent series resistance (ESR) capacitors are an ideal selection, with a typical value of 1 μF. Capacitor values less than 1 μF can be used, but the maximum output can be reduced. It is therefore recommended to validate the design with thorough testing.

4.2 Power-Supply Decoupling Capacitors

The DRV602 is a DirectPath™ line driver amplifier that requires adequate power-supply decoupling to ensure that noise and total harmonic distortion (THD) are low. A good low ESR ceramic capacitor, C17 (1 μ F typical), placed as close as possible to the device VDD leads is the best option. Placing this decoupling capacitor close to the DRV602 device is important for amplifier performance. For filtering lower-frequency noise signals, a 10- μ F or greater capacitor placed near the audio amplifier may also help, but is not required in most applications because of the high PSRR of the DRV602.

The charge pump circuit does apply ripple current on the VDD line, and an LC or RC filter may be needed if noise-sensitive audio devices share the VDD supply.

4.3 Using the DRV602 as a Second-Order, Low-Pass Filter in Single-Ended Input Mode

Several audio digital-to-audio converters (DACs) used in typical consumer applications require an external low-pass filter to remove out-of-band noise. This function is also possible with the DRV602; the EVM is configured as a 40-kHz, second-order active Butterworth filter to accomplish this filtering using an MFB (Multiple Feed Back) topology. Furthermore, the DRV602 requires an ac-coupling capacitor to remove dc content from the source.

The recommended component values can be calculated with the help of the TI [FilterPro](http://focus.ti.com/docs/toolsw/folders/print/filterpro.html) active filter design program available at <http://focus.ti.com/docs/toolsw/folders/print/filterpro.html> on the TI web site. [Figure 3](#) illustrates the circuit design for this configuration.

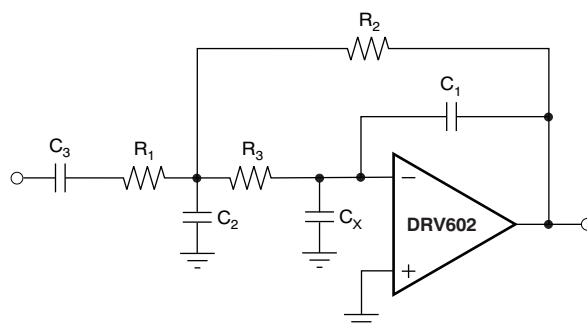

Figure 3. Second-Order, Active Low-Pass Filter

[Figure 3](#) uses the component references also used in the FilterPro software. Various recommendation for filter and gain settings are listed in [Table 3](#).

Table 3. DRV602EVM2 Filter Specifications

FilterPro			C1'	C2'	C3'	R1'	R2'	R3'
Gain	High Pass	Low Pass	C23	C21	C13	R11	R15	R13
			C24	C22	C14	R12	R16	R14
-1 V/V	16 Hz	40 kHz	100 pF	680 pF	1 μ F	10 k Ω	10 k Ω	24 k Ω
-1.5 V/V	19 Hz	40 kHz	68 pF	680 pF	1 μ F	8.2 k Ω	12 k Ω	30 k Ω
-2 V/V	11 Hz	40 kHz	15 pF	150 pF	1 μ F	33 k Ω	68 k Ω	100 k Ω
-2 V/V	11 Hz	30 kHz	47 pF	470 pF	1 μ F	15 k Ω	30 k Ω	43 k Ω
-3.33 V/V	12 Hz	40 kHz	33 pF	470 pF	1 μ F	13 k Ω	43 k Ω	43 k Ω
-10 V/V	15 Hz	30 kHz	22 pF	1 nF	2.2 μ F	4.7 k Ω	47k Ω	27 k Ω

The resistor values should be low value to achieve low noise, but should be of high enough value to obtain a small size ac-coupling capacitor. With the proposed values of 33 k Ω , 68 k Ω , and 100 k Ω , a dynamic range (DYR) of 102 dB can be achieved with a small 1- μ F input ac-coupling capacitor.

The MFB filter structure demands an op amp that is unity-gain stable at high frequencies; this requirement can be relaxed by adding the C_X capacitor value to be equal to C_1 . The DRV602 is unity-gain stable, but stray capacitance and inductance from the PCB layout can affect the phase margin. Therefore, we recommend adding C_X .

4.4 Using the DRV602 as a Differential Input, Second-Order Low-Pass Filter

The single-ended input, second-order filter described in Section 4.3 can easily be extended to have a differential input, as shown in Figure 4.

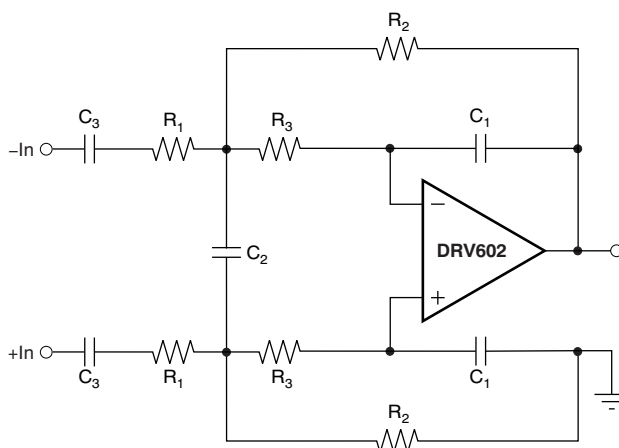

Figure 4. Differential Input, Second-Order Active Low-Pass Filter

C_2 can be split into separate capacitors to ground with the double value; this technique increases the common-mode filtering. Another capacitor, C_X , set equal to C_1 can continue to be used from the negative input to ground to limit the high-frequency gain to 2.

As with the single-ended input, the differential input filter component values can be calculated with the help of the TI [FilterPro](#) active filter design program available on the TI web site.

5 Layout Recommendations

5.1 SGND and PGND Connections

The SGND and GND pins of the DRV602 must be routed separately back to the decoupling capacitor in order to facilitate proper device operation. If the SGND pins are connected directly to each other, the device functions without risk of failure, but noise and THD performance can be reduced.

On the DRV602EVM2, a star ground routing pattern is used; the star point is located directly below the DRV602 device itself.

6 DRV602EVM2 Performance

This section discusses the DRV602EVM2 overall performance in key parametric areas. [Table 4](#) through [Table 7](#) summarize the EVM specifications.

Note: All electrical and audio specifications are typical values.

Table 4. General Test Conditions⁽¹⁾

General Test Conditions		Notes
Supply voltage	5.0 V	
Load impedance	2.5 k Ω	
Input signal	1 kHz sine	
Measurement filter	AES17	

⁽¹⁾ These test conditions are used for all tests, unless otherwise specified.

Table 5. Electrical Data

Electrical Data		Notes/Conditions
Output voltage, 2500 Ω	2.2 V _{RMS}	1 kHz, THD+N = 1%, T _A = +25°C
Output voltage, 100 k Ω	2.3 V _{RMS}	1 kHz, THD+N = 1%, T _A = +25°C
Supply current	< 20 mA	1 kHz, V _O = 2 mV _{RMS} at 2.5 k Ω , including linear regulator and LED
Supply current	< 20 mA	1 kHz, V _O = 2 V _{RMS} at 2.5 k Ω , including linear regulator and LED

Table 6. Audio Performance Analog Input

Audio Performance Analog Input			Notes/Conditions
THD+N, 2.5 k Ω	0.02 V_{RMS}	< 0.150 %	20 Hz to 20 kHz (Noise limited)
THD+N, 2.5 k Ω	0.2 V_{RMS}	< 0.015 %	2 Hz to 20 kHz (Noise limited)
THD+N, 2.5 k Ω	2 V_{RMS}	< 0.060 %	2 Hz to 20 kHz
THD+N, 100 k Ω	0.02 V_{RMS}	< 0.150 %	20 Hz to 20 kHz (Noise limited)
THD+N, 100 k Ω	0.2 V_{RMS}	< 0.015 %	20 Hz to 20 kHz (Noise limited)
THD+N, 100 k Ω	2 V_{RMS}	< 0.050 %	20 Hz to 20 kHz
Dynamic range		> 102 dB	Ref: 3 V_{RMS} , A-weighted, AES17 filter
Noise voltage		< 18 μV_{RMS}	A-weighted, AES17 filter
DC offset		< 5 mV	No signal, 2.5-k Ω load
Channel separation		> 90 dB	1 kHz, V_{RMS}
Frequency response: 20 Hz to 20 kHz		± 0.5 dB	2 V_{RMS} / 2.5 k Ω

Table 7. Physical Specifications

Physical Specifications		Notes/Conditions
PCB dimensions	60 \times 60 \times 25 mm	Width \times Length \times Height (mm)
Total weight	40 g	Components + PCB + Mechanics

6.1 THD+N versus Voltage (Analog Input)

Up to approximately 1 V_{RMS} , THD+N is dominated by the noise element, as shown in Figure 5.

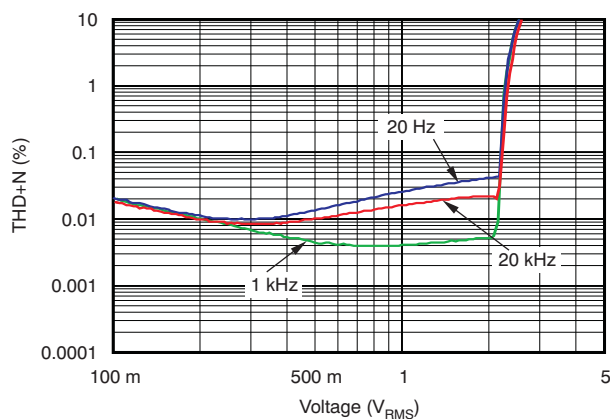
Figure 5. THD+N versus Voltage

6.2 THD+N vs Frequency

Figure 6 illustrates characteristic performance for THD+N versus frequency.

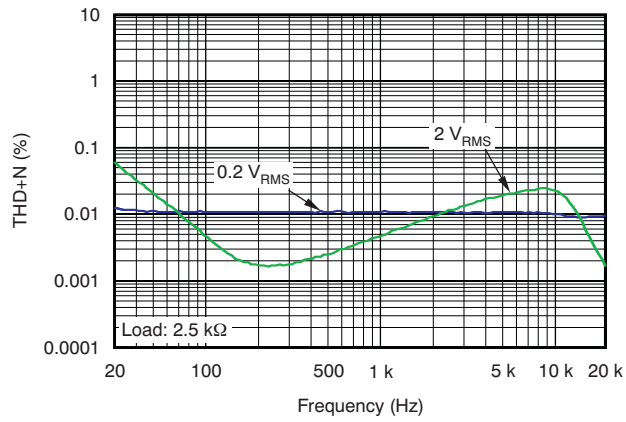

Figure 6. THD+N versus Frequency

6.3 FFT Spectrum with -60dBFS Tone

For the FFT plot shown in Figure 7, the reference voltage is $2 V_{RMS}$ and the FFT size is 16 k.

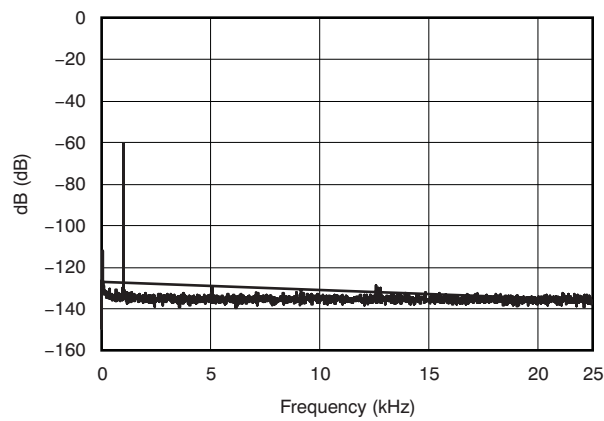

Figure 7. FFT Spectrum with -60-dBFS Tone

6.4 Channel Separation

Figure 8 illustrates the channel separation. The output signal and the reference voltage are both $2 V_{RMS}$, while the load is $2.5\text{ k}\Omega$.

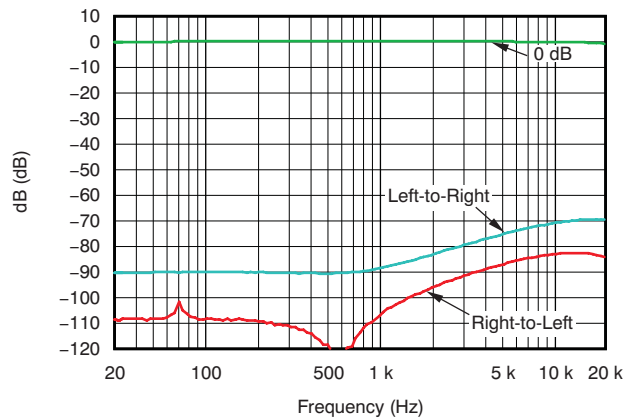

Figure 8. Channel Separation

6.5 Frequency Response

In Figure 9, the measurement bandwidth filter is set to 500 kHz with a load of $2.5\text{ k}\Omega$.

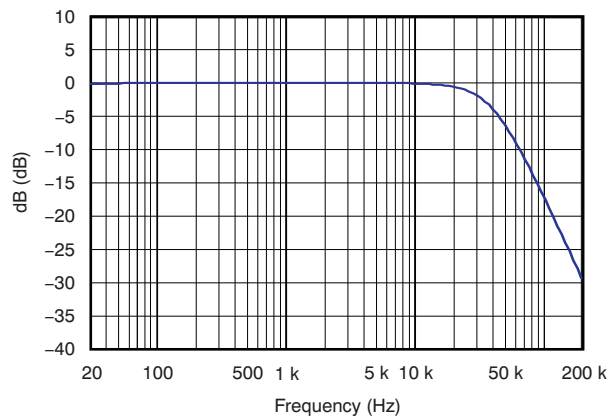

Figure 9. Frequency Response

6.6 Pop/Click (Enable)

The characteristic performance for pop and click interference is shown with and without an input signal applied, with a load of 2.5 kΩ. Measurement results are presented in a time domain domain.

For Figure 10, the power supply is applied, and then the shutdown signal is released. The shutdown signal triggers the measuring system.

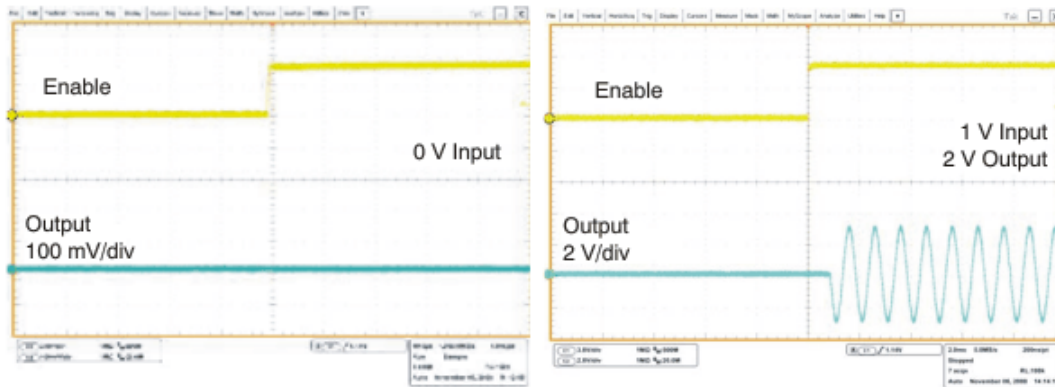

Figure 10. Pop/Click (Enable)

6.7 Pop/Click (Disable)

As with Section 6.6, characteristic performance for pop and click interference is shown with and without an input signal applied, with a load of 2.5 kΩ. Measurement results are again presented in a time domain format.

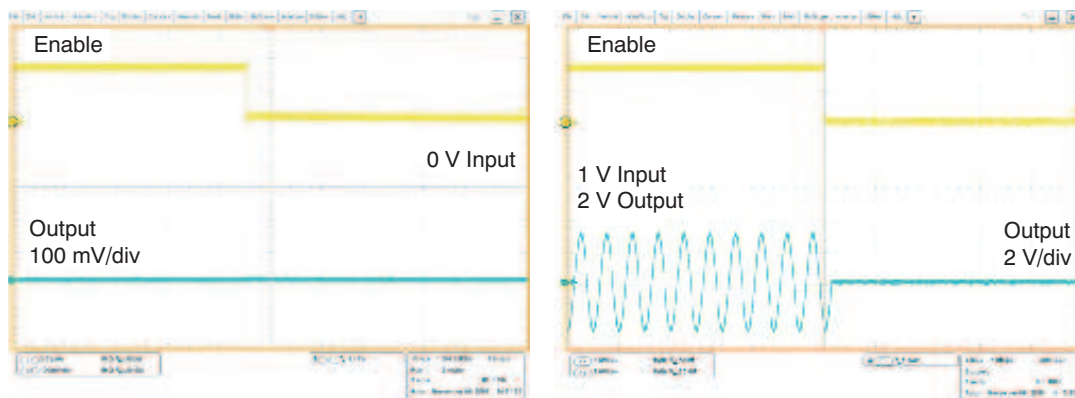

Figure 11. Pop/Click (Disable)

7 Related Documentation from Texas Instruments

The following related documents are available through the Texas Instruments web site at <http://www.ti.com>. These documents have detailed descriptions of the integrated circuits used in the design of the DRV602EVM2.

Table 8. Related Documentation

Part Number	Literature Number
DRV602	SLOS572
TPS3825-33	SLVS165
TLV1117-33C	SLVS561

8 Design Documentation

8.1 Schematics

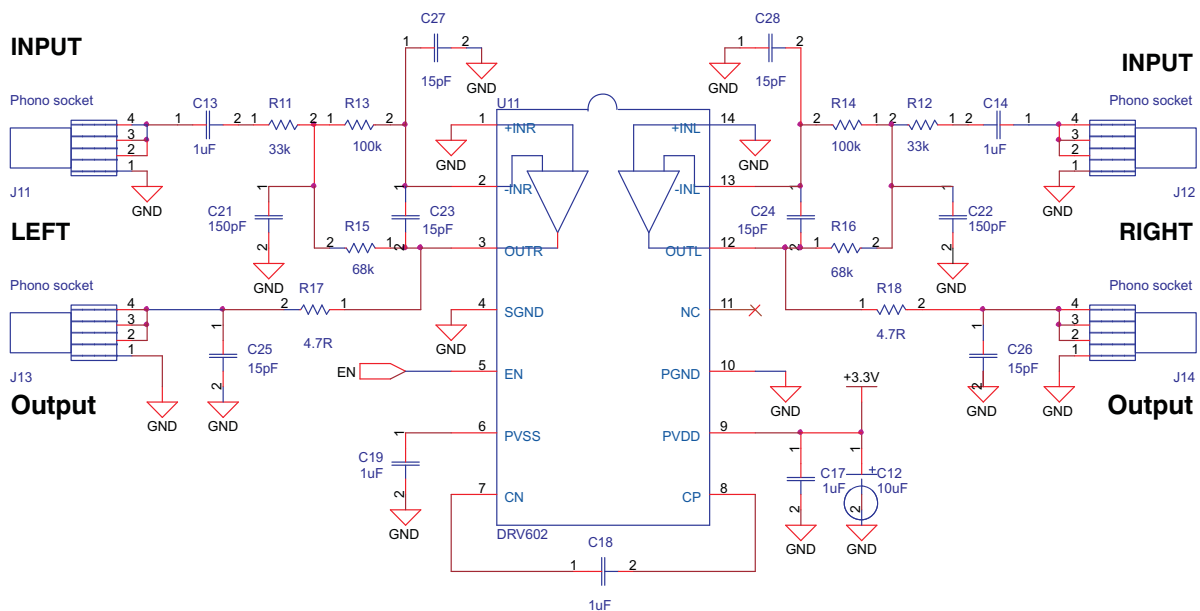
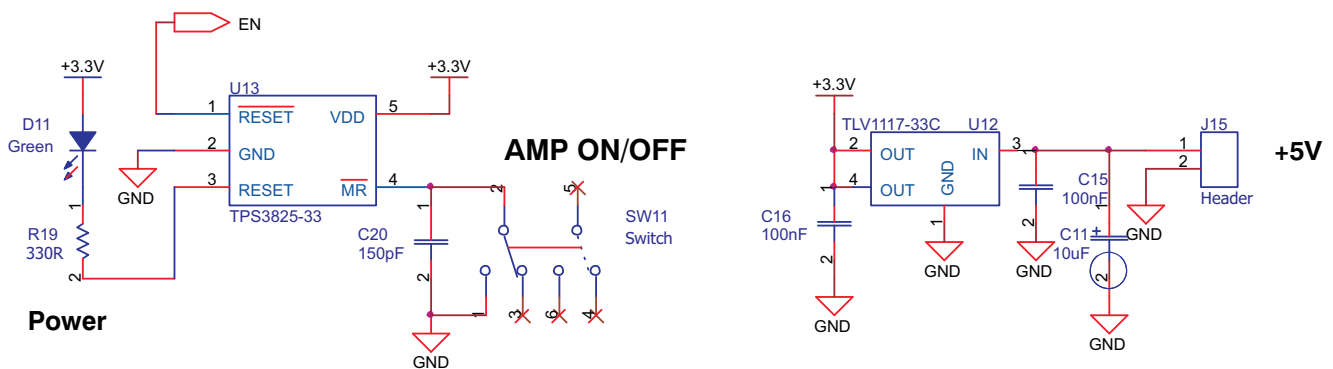
Figure 12. DRV602EVM2 Schematic: DRV602

Figure 13. DRV602EVM2 Schematic: On/Off and Regulator

8.2 Parts List

The bill of materials (BOM) for the DRV602EVM2 is listed in [Table 9](#).

Table 9. Bill of Materials

Qty	Part Reference	Description	Manufacturer	Mfr Part No
1	R19	1.0 k Ω / 100mW / 5% / 0603 Thick Film Resistor	Yageo	RC0603JR-071KL
2	R13, R14	100 k Ω / 100mW / 5% / 0603 Thick Film Resistor	Yageo	RC0603JR-07100KL
2	R11, R12	33 k Ω / 100mW / 5% / 0603 Thick Film Resistor	Yageo	RC0603JR-0733KL
2	R17, R18	4.7 Ω / 100mW / 5% / 0603 Thick Film Resistor	Yageo	RC0603JR-074R7L
2	R15, R16	68 k Ω / 100 mW / 5% / 0603 Thick Film Resistor	Yageo	RC0603JR-0768KL
5	C13, C14, C17, C18, C19	Ceramic 1 μ F / 16V / 20% X7R 0805 Capacitor	BC Components	0805B105M160NT
2	C1,5 C16	Ceramic 100 nF / 16V / 20% X7R 0603 Capacitor	Vishay	VJ0603Y104MXJ
6	C23, C24, C25, C26, C27, C28	Ceramic 15 pF / 50V / 10% NP0 0603 Capacitor	BC Components	0603N150K500NT
3	C20, C21, C22	Ceramic 150 pF / 50V / 10% NP0 0603 Capacitor	BC Components	0603N151K500NT
2	C11, C12	Electrolytic 10 μ F / 16V / 20% Aluminium 2mm ϕ 5mm	Panasonic	ECA1CM100
1	D11	Light Emitting Green Green LED (0603)	Toshiba	TLGU1008
1	U11	DRV602 / DirectPath(TM) Diff Audio Line Driver w. adjustable gain.	Texas Instruments	DRV602PW
1	U13	TPS3825-33 / 3.3-V Supply Voltage Supervisor (SOP5-DBV)	Texas Instruments	TPS3825-33DBVT
1	U12	TLV1117-33C / 3.3-V/800-mA Positive Voltage Regulator (SOT4-DCY)	Texas Instruments	TLV1117-33CDCYR
1	J15	2 pins / 1 row / 2,54 mm Pitch Vertical Male Friction lock Pin Header	Molex	22-27-2021
4	J11, J12, J13, J14	Horizontal Female with Switch Coax Phono socket	Chunfeng	RJ843-4W
1	SW11	Switch DPDT PCB Mount Switch	NKK-Nikkai	G-22-AP
1	PCB11	A851-PCB-001_1.00 / DRV602EVM2 Printed Circuit Board (ver. 2.00)	Printline	A851-PCB-001(2.00)

8.3 PCB Specification

Table 10 summarizes the specifications for the evaluation board PCB.

Table 10. PCB Specifications

Board Identification	A851-PCB-001(2.00)
Board type	Double-sided plated-through board
Laminate type	FR4
Laminate thickness	1,0 mm
Copper thickness	35 μm (including plating exterior layers)
Copper plating of holes	> 25 μm
Minimum hole diameter	0,3 mm
Silkscreen, component side	White; remove silkscreen from solder and pre-tinned areas
Silkscreen, solder side	None
Soldermask, component side	Green
Soldermask, solder side	Green
Protective coating	Solder coating and chemical silver on free copper
Electrical test	PCB must be electrically tested
Manufactured to	PERFAG 2E (www.perfag.dk)
Aperture table	PERFAG 10A (www.perfag.dk)
Board dimensions	60 mm x 60 mm

8.4 PCB Layers

Gerber files are available for download at the DRV602EVM2 product folder page on the TI web site. Component placement and board layout are illustrated in Figure 14, Figure 15, and Figure 16, respectively.

Note: Board layouts are not to scale. These figures are intended to show how the board is laid out; they are not intended to be used for manufacturing DRV602EVM2 PCBs.

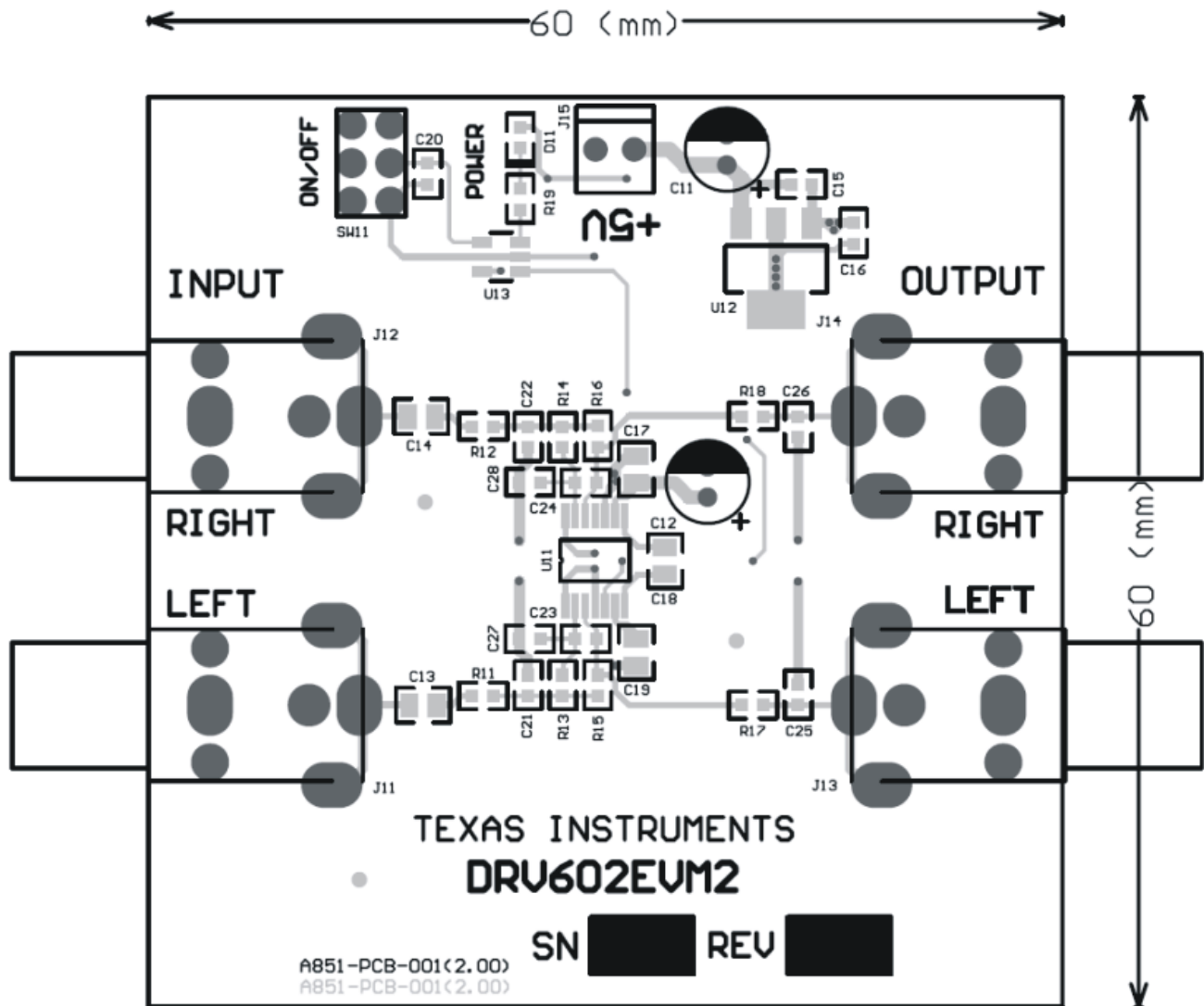

Figure 14. DRV602EVM2 PCB Component Placement

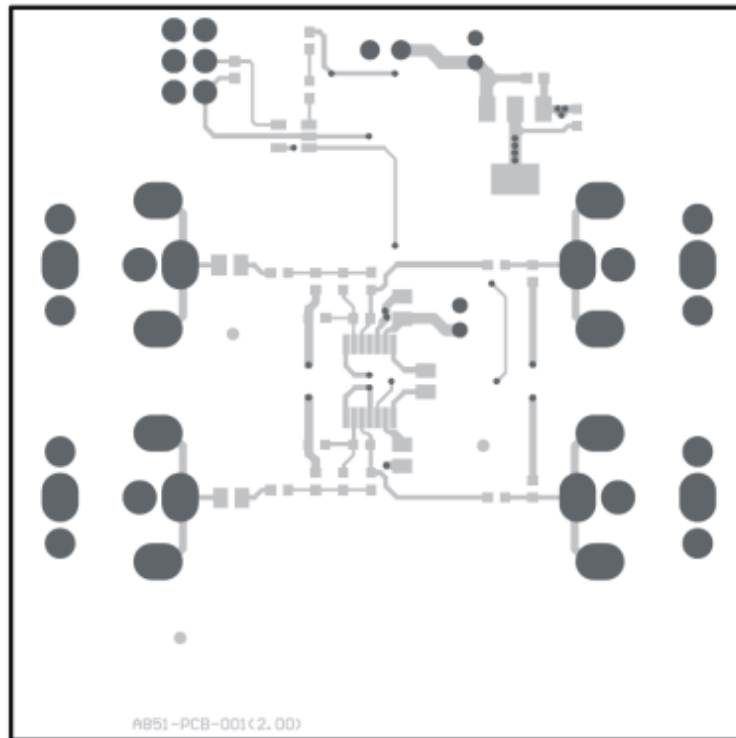

Figure 15. DRV602EVM2 PCB Top Layer

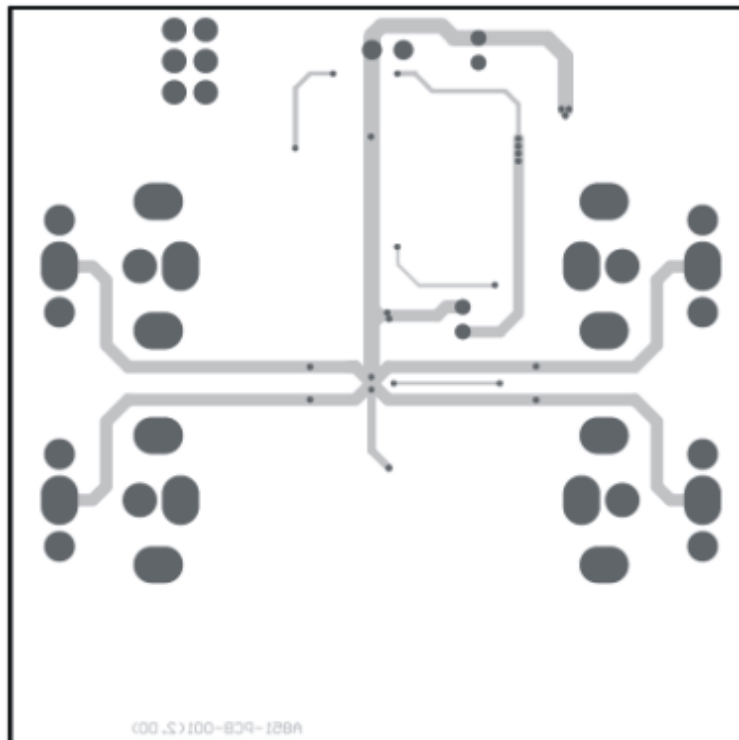

Figure 16. DRV602EVM2 PCB Bottom Layer

EVALUATION BOARD/KIT IMPORTANT NOTICE

Texas Instruments (TI) provides the enclosed product(s) under the following conditions:

This evaluation board/kit is intended for use for **ENGINEERING DEVELOPMENT, DEMONSTRATION, OR EVALUATION PURPOSES ONLY** and is not considered by TI to be a finished end-product fit for general consumer use. Persons handling the product(s) must have electronics training and observe good engineering practice standards. As such, the goods being provided are not intended to be complete in terms of required design-, marketing-, and/or manufacturing-related protective considerations, including product safety and environmental measures typically found in end products that incorporate such semiconductor components or circuit boards. This evaluation board/kit does not fall within the scope of the European Union directives regarding electromagnetic compatibility, restricted substances (RoHS), recycling (WEEE), FCC, CE or UL, and therefore may not meet the technical requirements of these directives or other related directives.

Should this evaluation board/kit not meet the specifications indicated in the User's Guide, the board/kit may be returned within 30 days from the date of delivery for a full refund. **THE FOREGOING WARRANTY IS THE EXCLUSIVE WARRANTY MADE BY SELLER TO BUYER AND IS IN LIEU OF ALL OTHER WARRANTIES, EXPRESSED, IMPLIED, OR STATUTORY, INCLUDING ANY WARRANTY OF MERCHANTABILITY OR FITNESS FOR ANY PARTICULAR PURPOSE.**

The user assumes all responsibility and liability for proper and safe handling of the goods. Further, the user indemnifies TI from all claims arising from the handling or use of the goods. Due to the open construction of the product, it is the user's responsibility to take any and all appropriate precautions with regard to electrostatic discharge.

EXCEPT TO THE EXTENT OF THE INDEMNITY SET FORTH ABOVE, NEITHER PARTY SHALL BE LIABLE TO THE OTHER FOR ANY INDIRECT, SPECIAL, INCIDENTAL, OR CONSEQUENTIAL DAMAGES.

TI currently deals with a variety of customers for products, and therefore our arrangement with the user **is not exclusive.**

TI assumes **no liability for applications assistance, customer product design, software performance, or infringement of patents or services described herein.**

Please read the User's Guide and, specifically, the Warnings and Restrictions notice in the User's Guide prior to handling the product. This notice contains important safety information about temperatures and voltages. For additional information on TI's environmental and/or safety programs, please contact the TI application engineer or visit www.ti.com/esh.

No license is granted under any patent right or other intellectual property right of TI covering or relating to any machine, process, or combination in which such TI products or services might be or are used.

FCC Warning

This evaluation board/kit is intended for use for **ENGINEERING DEVELOPMENT, DEMONSTRATION, OR EVALUATION PURPOSES ONLY** and is not considered by TI to be a finished end-product fit for general consumer use. It generates, uses, and can radiate radio frequency energy and has not been tested for compliance with the limits of computing devices pursuant to part 15 of FCC rules, which are designed to provide reasonable protection against radio frequency interference. Operation of this equipment in other environments may cause interference with radio communications, in which case the user at his own expense will be required to take whatever measures may be required to correct this interference.

EVM WARNINGS AND RESTRICTIONS

It is important to operate this EVM within the input voltage range of 0 V to 3 V_{RMS} and the output voltage range of 0 V to 3.3 V.

Exceeding the specified input range may cause unexpected operation and/or irreversible damage to the EVM. If there are questions concerning the input range, please contact a TI field representative prior to connecting the input power.

Applying loads outside of the specified output range may result in unintended operation and/or possible permanent damage to the EVM. Please consult the EVM User's Guide prior to connecting any load to the EVM output. If there is uncertainty as to the load specification, please contact a TI field representative.

During normal operation, some circuit components may have case temperatures greater than +60°C. The EVM is designed to operate properly with certain components above +40°C as long as the input and output ranges are maintained. These components include but are not limited to linear regulators, switching transistors, pass transistors, and current sense resistors. These types of devices can be identified using the EVM schematic located in the EVM User's Guide. When placing measurement probes near these devices during operation, please be aware that these devices may be very warm to the touch.

Mailing Address: Texas Instruments, Post Office Box 655303, Dallas, Texas 75265
Copyright © 2009, Texas Instruments Incorporated

IMPORTANT NOTICE

Texas Instruments Incorporated and its subsidiaries (TI) reserve the right to make corrections, modifications, enhancements, improvements, and other changes to its products and services at any time and to discontinue any product or service without notice. Customers should obtain the latest relevant information before placing orders and should verify that such information is current and complete. All products are sold subject to TI's terms and conditions of sale supplied at the time of order acknowledgment.

TI warrants performance of its hardware products to the specifications applicable at the time of sale in accordance with TI's standard warranty. Testing and other quality control techniques are used to the extent TI deems necessary to support this warranty. Except where mandated by government requirements, testing of all parameters of each product is not necessarily performed.

TI assumes no liability for applications assistance or customer product design. Customers are responsible for their products and applications using TI components. To minimize the risks associated with customer products and applications, customers should provide adequate design and operating safeguards.

TI does not warrant or represent that any license, either express or implied, is granted under any TI patent right, copyright, mask work right, or other TI intellectual property right relating to any combination, machine, or process in which TI products or services are used. Information published by TI regarding third-party products or services does not constitute a license from TI to use such products or services or a warranty or endorsement thereof. Use of such information may require a license from a third party under the patents or other intellectual property of the third party, or a license from TI under the patents or other intellectual property of TI.

Reproduction of TI information in TI data books or data sheets is permissible only if reproduction is without alteration and is accompanied by all associated warranties, conditions, limitations, and notices. Reproduction of this information with alteration is an unfair and deceptive business practice. TI is not responsible or liable for such altered documentation. Information of third parties may be subject to additional restrictions.

Resale of TI products or services with statements different from or beyond the parameters stated by TI for that product or service voids all express and any implied warranties for the associated TI product or service and is an unfair and deceptive business practice. TI is not responsible or liable for any such statements.

TI products are not authorized for use in safety-critical applications (such as life support) where a failure of the TI product would reasonably be expected to cause severe personal injury or death, unless officers of the parties have executed an agreement specifically governing such use. Buyers represent that they have all necessary expertise in the safety and regulatory ramifications of their applications, and acknowledge and agree that they are solely responsible for all legal, regulatory and safety-related requirements concerning their products and any use of TI products in such safety-critical applications, notwithstanding any applications-related information or support that may be provided by TI. Further, Buyers must fully indemnify TI and its representatives against any damages arising out of the use of TI products in such safety-critical applications.

TI products are neither designed nor intended for use in military/aerospace applications or environments unless the TI products are specifically designated by TI as military-grade or "enhanced plastic." Only products designated by TI as military-grade meet military specifications. Buyers acknowledge and agree that any such use of TI products which TI has not designated as military-grade is solely at the Buyer's risk, and that they are solely responsible for compliance with all legal and regulatory requirements in connection with such use.

TI products are neither designed nor intended for use in automotive applications or environments unless the specific TI products are designated by TI as compliant with ISO/TS 16949 requirements. Buyers acknowledge and agree that, if they use any non-designated products in automotive applications, TI will not be responsible for any failure to meet such requirements.

Following are URLs where you can obtain information on other Texas Instruments products and application solutions:

Products

Amplifiers	amplifier.ti.com
Data Converters	dataconverter.ti.com
DLP® Products	www.dlp.com
DSP	dsp.ti.com
Clocks and Timers	www.ti.com/clocks
Interface	interface.ti.com
Logic	logic.ti.com
Power Mgmt	power.ti.com
Microcontrollers	microcontroller.ti.com
RFID	www.ti-rfid.com
RF/IF and ZigBee® Solutions	www.ti.com/lprf

Applications

Audio	www.ti.com/audio
Automotive	www.ti.com/automotive
Broadband	www.ti.com/broadband
Digital Control	www.ti.com/digitalcontrol
Medical	www.ti.com/medical
Military	www.ti.com/military
Optical Networking	www.ti.com/opticalnetwork
Security	www.ti.com/security
Telephony	www.ti.com/telephony
Video & Imaging	www.ti.com/video
Wireless	www.ti.com/wireless

Mailing Address: Texas Instruments, Post Office Box 655303, Dallas, Texas 75265
Copyright © 2009, Texas Instruments Incorporated