

# *Installation Manual*

## **CLASS A AIS**

Model **FA-170**

---

<b>SAFETY INSTRUCTIONS .....</b>	<b>i</b>
<b>SYSTEM CONFIGURATION .....</b>	<b>ii</b>
<b>EQUIPMENT LISTS.....</b>	<b>iii</b>
<b>1. MOUNTING.....</b>	<b>1-1</b>
1.1 How to Install the Antenna Unit(s) .....	1-1
1.2 How to Install the FA-1702 Monitor Unit .....	1-10
1.3 How to Install the FA-1701 Transponder Unit.....	1-15
1.4 How to Install the FA-1703 Pilot Plug Unit (option).....	1-16
1.5 How to Install the PR-240 Power Supply (option).....	1-17
<b>2. WIRING.....</b>	<b>2-1</b>
2.1 Connection Overview .....	2-1
2.2 How to Fabricate the Cables.....	2-2
2.3 Unit Interconnection .....	2-4
2.4 How to Terminate COM Ports (For IEC 61162-1/2 signal) .....	2-9
2.5 How to Change the Ship's Mains Specifications.....	2-10
<b>3. SETTINGS AND ADJUSTMENTS .....</b>	<b>3-1</b>
3.1 How to Set MMSI, IMO No., Name and Call Sign.....	3-2
3.2 Inland AIS Specific Settings.....	3-3
3.3 How to Set GPS Antenna Position.....	3-5
3.4 How to Enable or Disable Alerts .....	3-6
3.5 How to Set Up the I/O Ports.....	3-7
3.6 Network Set Up.....	3-9
3.7 SERVICE Menu Operations.....	3-10
<b>APPENDIX 1 JIS CABLE GUIDE .....</b>	<b>AP-1</b>
<b>APPENDIX 2 DIGITAL INTERFACE .....</b>	<b>AP-2</b>
<b>PACKING LIST .....</b>	<b>A-1</b>
<b>OUTLINE DRAWINGS .....</b>	<b>D-1</b>
<b>INTERCONNECTION DIAGRAM .....</b>	<b>S-1</b>

**ECF**

(Elemental Chlorine Free)

The paper used in this manual  
is elemental chlorine free.

**FURUNO ELECTRIC CO., LTD.**

9-52 Ashihara-cho,  
Nishinomiya, 662-8580, JAPAN

• FURUNO Authorized Distributor/Dealer

All rights reserved. Printed in Japan

Pub. No. IME-44900-F

(TASU) FA-170

A : NOV. 2015

F : MAY 09, 2019





0 0 0 1 9 1 0 9 3 1 5



# SAFETY INSTRUCTIONS

The installer must read the safety instructions before attempting to install this equipment.

 <b>WARNING</b>	Indicates a potentially hazardous situation which, if not avoided, could result in death or serious injury.
 <b>CAUTION</b>	Indicates a potentially hazardous situation which, if not avoided, can result in minor or moderate injury.

 Warning, Caution	 Prohibitive Action	 Prohibitive Action
--	--	--

## WARNING

 **ELECTRICAL SHOCK HAZARD**  
**Do not open the equipment unless totally familiar with electrical circuits and service manual.**  
 Only qualified personnel should work inside the equipment.

 **Do not approach the antenna closer than listed below when it is transmitting.**  
 The antenna emits radio waves that can be harmful to the human body.

RF power density on antenna aperture	Distance
100 W/m <sup>2</sup>	N/A
10 W/m <sup>2</sup>	0.04 m
2 W/m <sup>2</sup>	0.09 m

 **Turn off the power at the switchboard before beginning the installation.**  
 Fire or electrical shock can result if the power is left on.

 **Do not install the equipment where it may get wet from rain or water splash.**  
 Water in the equipment can result in fire, electrical shock or damage the equipment.

 **Be sure that the power supply is compatible with the voltage rating of the equipment.**  
 Connection of an incorrect power supply can cause fire or damage the equipment. The voltage rating of the equipment appears on the label above the power connector.

## CAUTION

 **Observe the following compass safe distances to prevent interference to a magnetic compass:**

Equipment	Standard compass	Steering compass	Equipment	Standard compass	Steering compass
FA-1701 Transponder unit	1.70 m	1.10 m	GVA-100-T	0.40 m	0.30 m
FA-1702 Monitor unit	0.65 m	0.40 m	DB-1	0.30 m	0.30 m
FA-1703 Pilot Plug unit	0.35 m	0.30 m	PR-240	0.90 m	0.60 m

 **Attach protective earth securely to the ship's body.**  
 The protective earth is required for the power supply to prevent electrical shock.

# SYSTEM CONFIGURATION

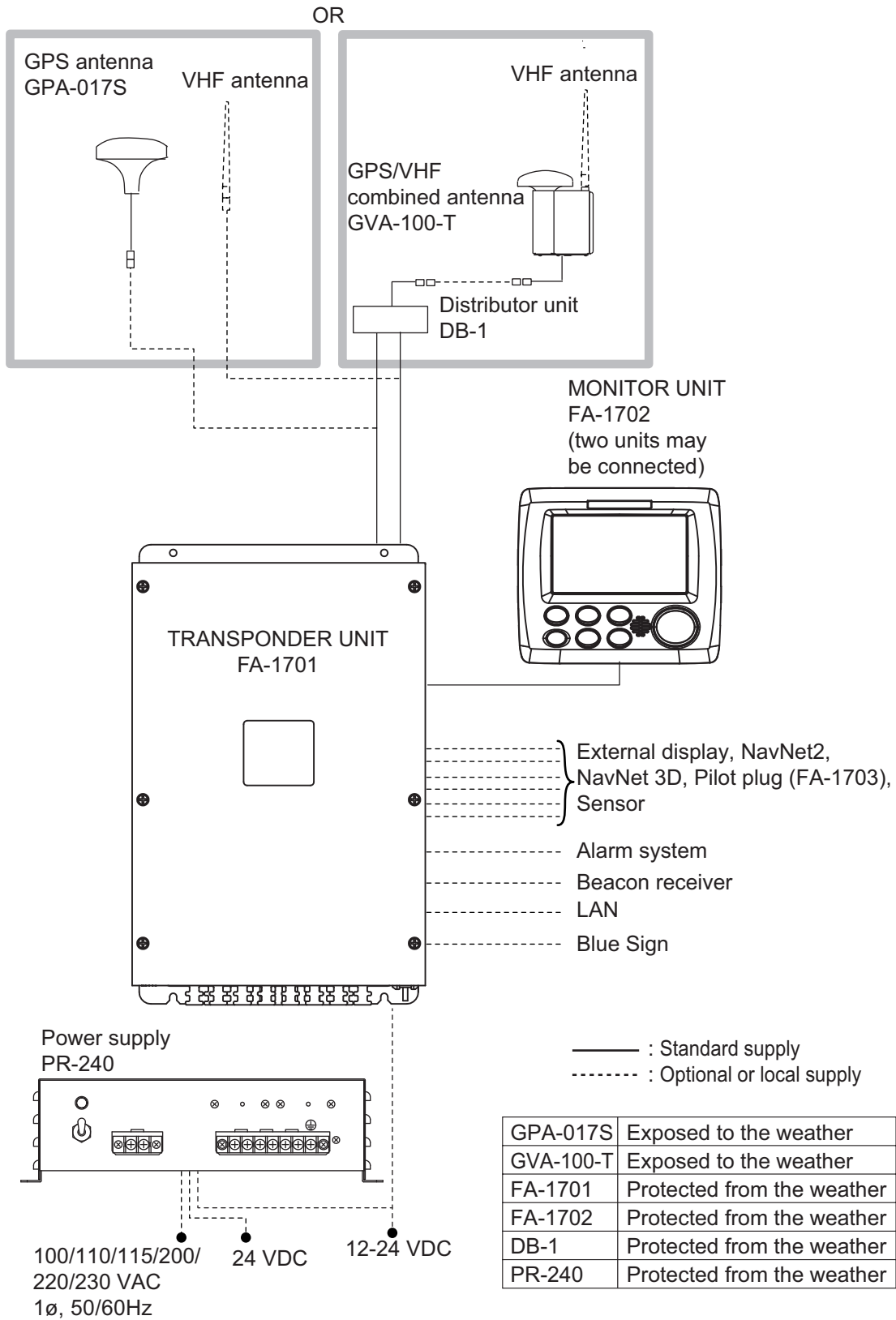

# EQUIPMENT LISTS

## Standard supply

Name	Type	Code no.	Qty	Remarks
Transponder Unit	FA-1701	—	1	
Monitor Unit	FA-1702	—	1	
GPS Antenna	GPA-017S	—	1	Select one.
GPS/VHF Combined Antenna	GVA-100-T	—	1	
Distributor Unit	DB-1	—	1	For GVA-100-T
Installation Materials	CP05-13600	000-029-284	1	For DB-1 (GVA-100-T) See table below for contents.
	CP05-13610	000-029-285	1	For DB-1 (GVA-100-T, Deep Sea) and GPA-017S See table below for contents.
	CP05-13620	000-029-286	1	For DB-1 (GVA-100-T) See table below for contents.
	CP24-00141	001-176-030	1	For GVA-100-T
	CP05-13630	000-029-287	1	For GPA-017S See table below for contents.
	CP05-13640	000-029-288	1	For GPA-017S See table below for contents.
Spare Parts	CP05-13701	001-426-520	1	For FA-1702
	SP05-06501	001-426-300	1	For FA-1701 (Type: FGMB 125V 8A PBF, 2 pcs. Code: 000-191-004-10)

## Installation materials

Installation materials	Contains			
	CP05-13601	CP24-00101	Z-AWG25X4P-SB L050	TNC-PS/PS-3D-L15M-R
CP05-13600	Y	Y	N	N
CP05-13610		N	N	N
CP05-13620		Y	Y	N
CP05-13630		N	Y	N
CP05-13640		N	Y	Y

## Optional supply

Name	Type	Code no.	Qty	Remarks
Pilot Plug Unit	FA-1703	—	1	
Monitor Unit	FA-1702	—	1	
Power Supply Unit	PR-240	—	1	
Distributor Unit	DB-1	—	1	For GVA-100-T
Antenna Cable Assembly	CP20-02700 (30M)	004-381-160	1	For GPA-017S (30 m)
	CP20-02720 (40M)	001-207-990	1	For GPA-017S (40 m)
	CP20-02710 (50M)	004-381-170	1	For GPA-017S (50 m)
Antenna Cable Set	CP24-00300	000-041-938	1	For GVA-100-T (30 m)
	CP24-00310	000-041-939	1	For GVA-100-T (50 m)
	CP24-00320	000-022-637	1	For GVA-100-T (40 m)

## EQUIPMENT LISTS

Name	Type	Code no.	Qty	Remarks
Mast Mounting Kit	CP20-01111	004-365-780	1	For GPA-017S
Antenna Fixing Bracket	N173F/FEC	001-474-350-00	1	For CX4-3/FEC (φ49-90)
	N174F/FEC	001-494-890-00	1	For CX4-3/FEC (φ30-61)
	CP05-14001	001-430-360	1	For FAB-151D
	4-310071	000-166-333-10	1	For FAB-151D
AD Converter	AD-100-E	000-040-110	1	
Mast Mounting Kit	OP24-5	005-954-510	1	For GVA-100-T
Front Fixing Panel	OP24-35	001-247-240	1	For FA-1702
F Mount Cushion Kit	OP05-141	001-436-880	1	
Installation Materials	CP03-28900 (10M)	000-082-658	1	LAN cable (10 m)
	CP03-28910 (20M)	000-082-659	1	LAN cable (20 m)
	CP03-28920 (30M)	000-082-660	1	LAN cable (30 m)
	CP03-28930 (50M)	000-084-368	1	LAN cable (50 m)
	CP03-28940 (100M)	000-090-429	1	LAN cable (100 m)
Antenna	CX4-3/FEC	001-474-340-00	1	
	FAB-151D	001-144-490-10	1	
Right Angle Mounting Base	NO. 13-QA330	001-111-910-10	1	For GPA-017S
L-Angle Mounting Base	NO. 13-QA310	001-111-900-10	1	For GPA-017S
Handrail Mounting Base	NO. 13-RC5160	001-111-920-10	1	For GPA-017S
Cable Assembly	TNC-PS/PS-3D-L15M-R	001-173-110-10	1	For connection to GPA-017S
	OP05-146-1	001-542-230	1	For connection between FA-1701 and FA-1702. Contains Z-AWG25X4P-SB L050 (5 m) and OP05-147.
	OP05-146-2	001-542-240	1	For connection between FA-1701 and FA-1702. Contains Z-AWG25X4P-SB L100 (10 m) and OP05-147.
Water Proof Kit	OP05-139	001-426-500	1	For FA-1702
Cable Protection Kit	OP05-147	001-542-590	1	For FA-1702, Cable packing for the cable assembly Z-AWG25X4P-SB L050 (5 m) or Z-AWG25X4P-SB L100 (10 m).
Replacement Kit	OP05-140	001-426-510	1	For FA-1702
EAIS Handbook	E42-01503-*	000-191-095-*	1	For EAIS users
Attaching the WSV label	E42-01604-*	000-192-102-*	1	For Inland AIS users

# 1. MOUNTING

## NOTICE

**Do not apply paint, anti-corrosive sealant or contact spray to coating or plastic parts of the equipment.**

Those items contain organic solvents that can damage coating and plastic parts, especially plastic connectors.

## 1.1 How to Install the Antenna Unit(s)

### 1.1.1 GPS antenna unit (GPA-017S)

Install the GPS antenna unit referring to the outline drawing at the back of this manual.

When selecting a mounting location for the antenna, keep in mind the following points.

- Select a location out of the radar beam. The radar beam will obstruct or prevent reception of the GPS satellite signal.
- There should be no interfering object within the line-of-sight to the satellites. Objects within line-of-sight to a satellite, for example, a mast, may block reception or prolong acquisition time.
- Mount the antenna unit as high as possible to keep it free of interfering objects and water spray, which can interrupt reception of GPS satellite signal if the water freezes.
- Referring to the drawing at the back of this manual, leave sufficient space between all antennas to avoid mutual interference.

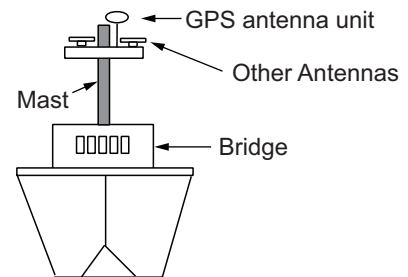

### How to extend the antenna cable

Three types of antenna cable extensions are optionally available.

#### a) Antenna cable set CP20-02700

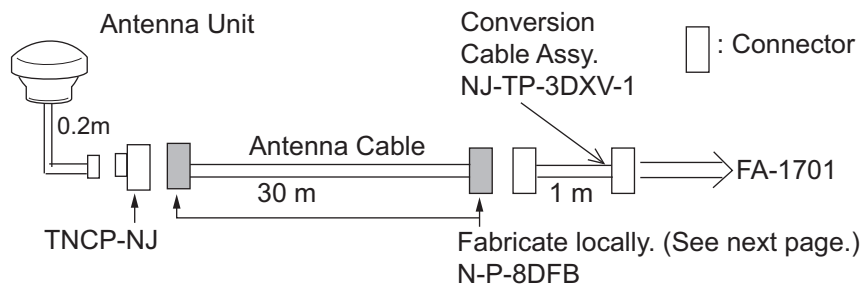

#### ● Securing and waterproofing the connector

Referring to the figures in section 2.2.1 secure and waterproof the connections.

- b) Antenna cable set CP20-02720 (8D-FB-CV, 40m)/CP20-02710 (8D-FB-CV, 50m)  
Connect the cable the same as a) above.

## 1. MOUNTING

### c) Cable type RG-10/UY (shipyard supply)

**Note:** The length of this cable should be less than 20 m to prevent signal loss. The coax. coupling cable assy. (type: NJ-TP-3DXV-1, code no. 000-123-809-10), coaxial connector (N-P-8DFB; supplied), vulcanizing tape and vinyl tape are required. Fabricate both ends of the cable as shown in the figure on the next page.

### How to attach the connector N-P-8DFB for cable 8D-FB-CV

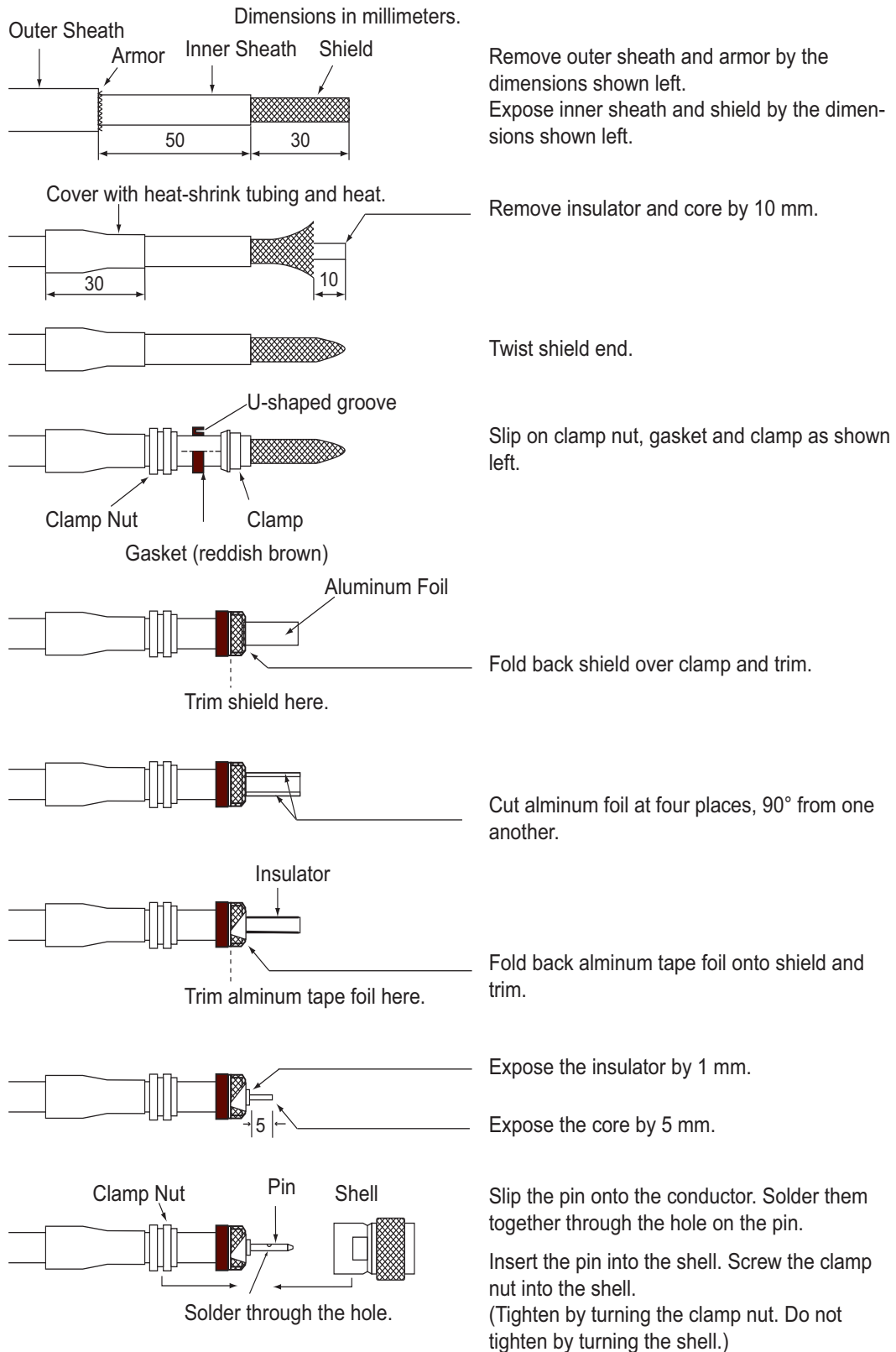



## 1.1.2 VHF antenna

### Requirements for the antenna

Select a good quality antenna that meets the requirement listed below:

- Frequency range: 155 to 164 MHz
- Impedance: 50 ohms
- Polarization: Vertical
- Handling power: 30W
- VSWR: Less than 1.5 (157 to 159 MHz)
- Quality: Able to withstand the marine environment

### Installation location

The location of the mandatory AIS VHF-antenna should be carefully considered. Digital communication is more sensitive than analog/voice communication to interference created by reflections in obstructions like masts and booms. It may be necessary to relocate the VHF radiotelephone antenna to minimize interference effects.

To minimize interference effects, the following guidelines apply:

- The AIS VHF antenna should be placed in an elevated position that is as free as possible with a minimum of 0.5 meters in the horizontal direction from constructions made of conductive materials. The antenna should not be installed close to any large vertical obstruction. The objective for the AIS VHF antenna is to see the horizon freely through 360 degrees.
- The AIS VHF antenna should be installed safely away from interfering high-power energy sources like radar and other transmitting radio antennas, preferably at least 3 meters away from and out of the transmitting beam.
- There should not be more than one antenna on the same plane. The AIS VHF antenna should be mounted directly above or below the ship's primary VHF radiotelephone antenna, with no horizontal separation and with a minimum of 2.8 meters vertical separation. If it is located on the same plane as other antennas, the distance apart should be at least 10 meters.

### Cabling

- The cable should be kept as short as possible to minimize signal attenuation. Coaxial cables equal to or better than RG10U/Y are recommended.
- All outdoor-installed connectors on coaxial cables should be fitted with preventive isolation such as vulcanizing tape to protect against water penetration into the antenna cable. Also, apply marine sealant at the antenna base to prevent water intrusion from the screw part of antenna base.
- Coaxial cables should be installed in separate signal cable channels/tubes and at least 10 cm away from power supply cables. Crossing of cables should be done at right angles (90°). The minimum bend radius of the coaxial cable should be 5 times the cable's outer diameter.

## 1. MOUNTING

- Install the VHF whip antenna referring to the outline drawing at the back of this manual. Separate this antenna from other VHF radiotelephone antennas as shown below to prevent interference to the FA-170.

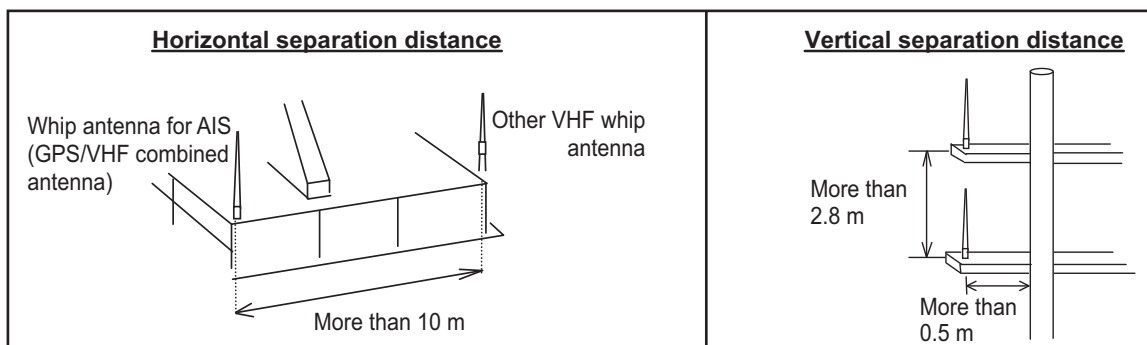

When coaxial cable RG-10/UJY (shipyard supply) is used, attach the coaxial plug M-P-7 (dockyard supply) as shown on the following page.

### How to attach the plug M-P-7

Lay the coaxial cable and attach an M-type plug (if necessary) to the cable as follows.

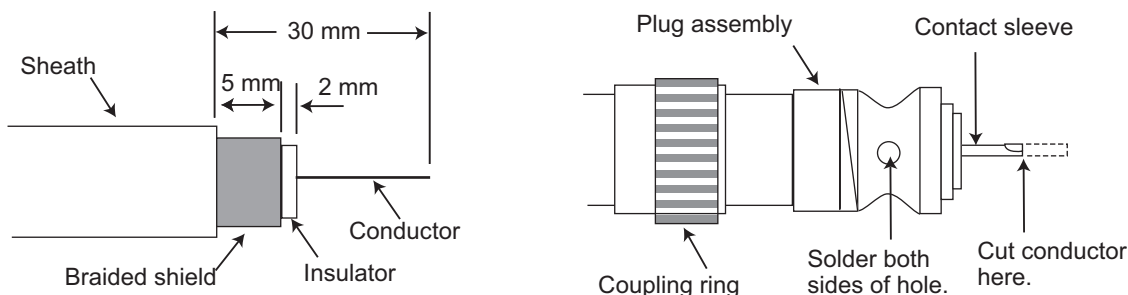

1. Remove the sheath by 30 mm.
2. Bare 23 mm of the center conductor. Trim braided shield by 5 mm and tin.
3. Slide coupling ring onto cable.
4. Screw the plug assembly on the cable.
5. Solder plug assembly to braided shield through solder holes. Solder contact sleeve to conductor.
6. Screw coupling ring into plug assembly.

### 1.1.3 GPS/VHF combined antenna (GVA-100-T)

Install the combined antenna unit referring to the outline drawing. When selecting a mounting location for the antenna, keep in mind the following points.

- Select a location out of the radar beam. The radar beam will obstruct or prevent reception of the GPS satellite signal.
- There should be no interfering object within the line-of-sight to the satellites. Objects within line-of-sight to a satellite, for example, a mast, may block reception or prolong acquisition time.
- Mount the antenna unit as high as possible. Mounting it this way keeps it free of interfering objects and water spray, which can interrupt reception of GPS satellite signal if the water freezes.

- Also, refer to the antenna installation guidelines on page 1-3.

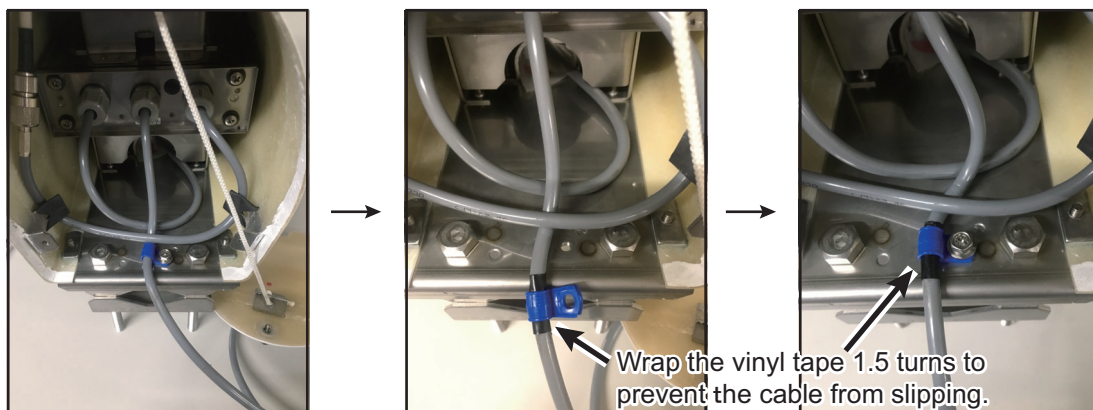
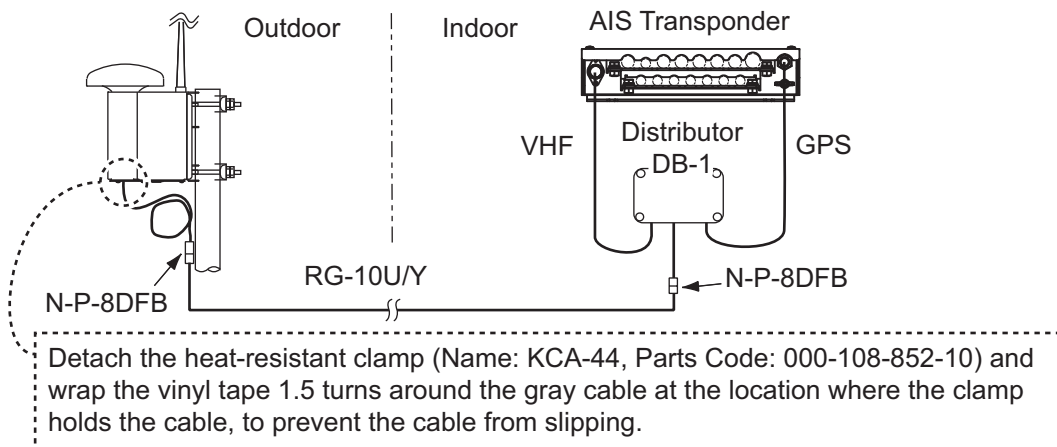

*Installation overview of GPS/VHF combined antenna*

**Note:** Where the mast on which the antenna is installed has a diameter of 60 mm to 80 mm, the optional mast installation kit is required (Model: OP24-5, Code: 005-954-510).

**Installing the VHF antenna CX4-3/FEC or FAB-151D to the combined antenna GVA-100-T**

The compatibility of VHF antenna (CX4-3/FEC or FAB-151D) with the GVA-100-T differs with GVA-100-T's serial number.

Compatibility of CX4-3/FEC, FAB-151D and GVA-100-T

Serial No.	FAB-151D	CX4-3/FEC
000101 to 019999	OK	NG
020000 and after	OK	OK

To install the VHF antenna CX4-3/FEC or FAB-151D to the combined antenna GVA-100-T (with serial number 020000 and after), follow the below procedures.

1. Unfasten the upset head bolts (M5, 4pcs.) at the back side of the GVA-100-T.

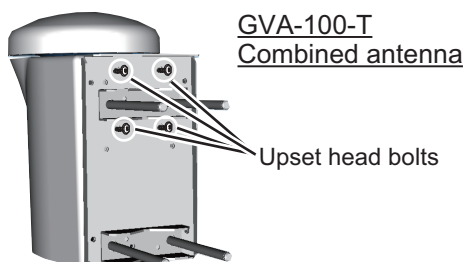

## 1. MOUNTING

2. Turn the GVA-100-T upside-down, then unfasten three screws with captive washers (M4, 3pcs.) on the bottom cover to detach it.

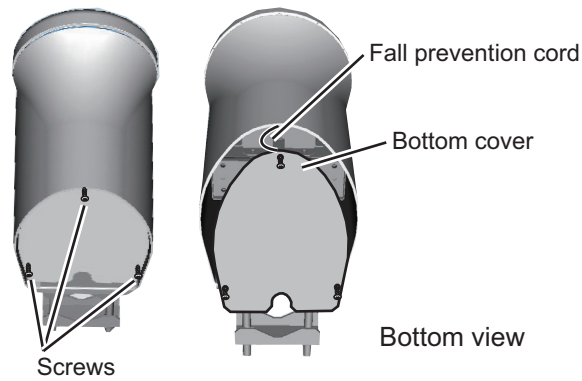

3. Remove the cushioning material from the connector of the cable (MP-3D-360) to connect with VHF antenna.

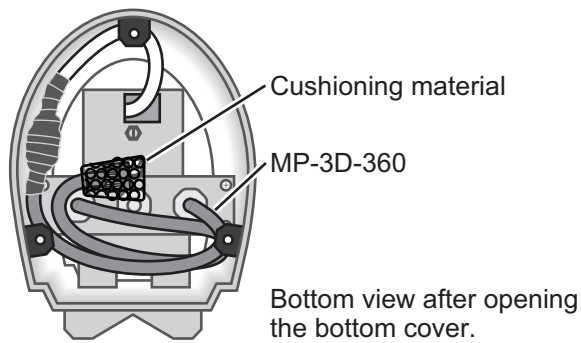

4. Insert the CX4-3/FEC or FAB-151D to the GVA-100-T from the connector side.

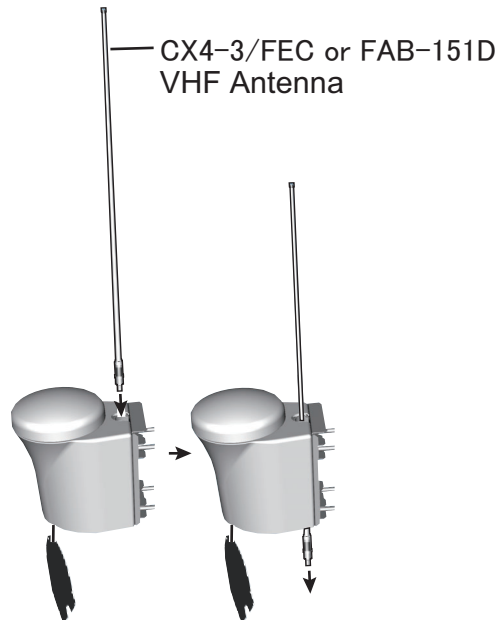

- Connect the MP-3D-360 connector to the VHF antenna and wrap the junction of the connectors with self-vulcanizing tape and vinyl tape.

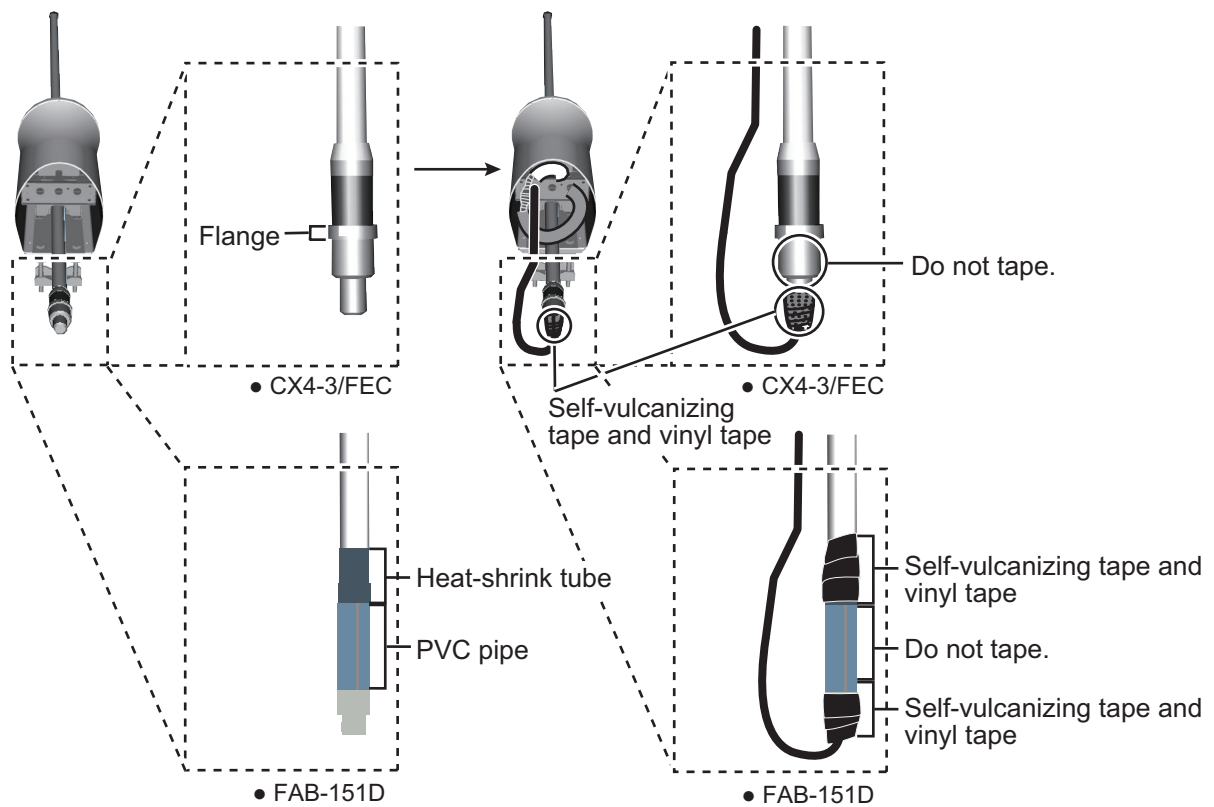

- Raise the CX4-3/FEC or FAB-151D upward, confirm that the flange fits the caulking and tighten with the upset head bolts unfastened with step 1.

For CX4-3/FEC

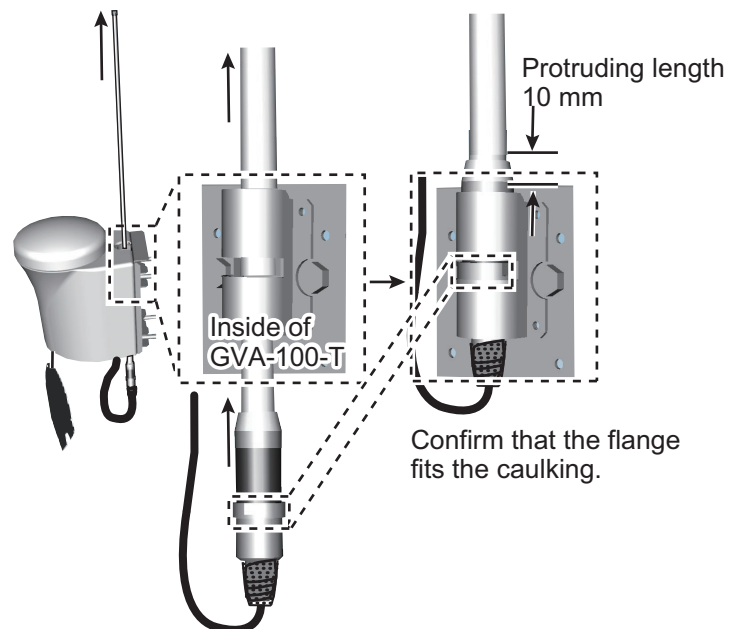

## 1. MOUNTING

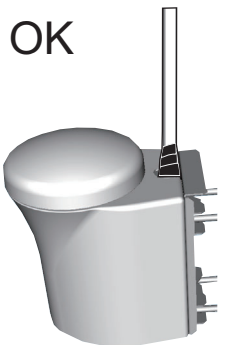
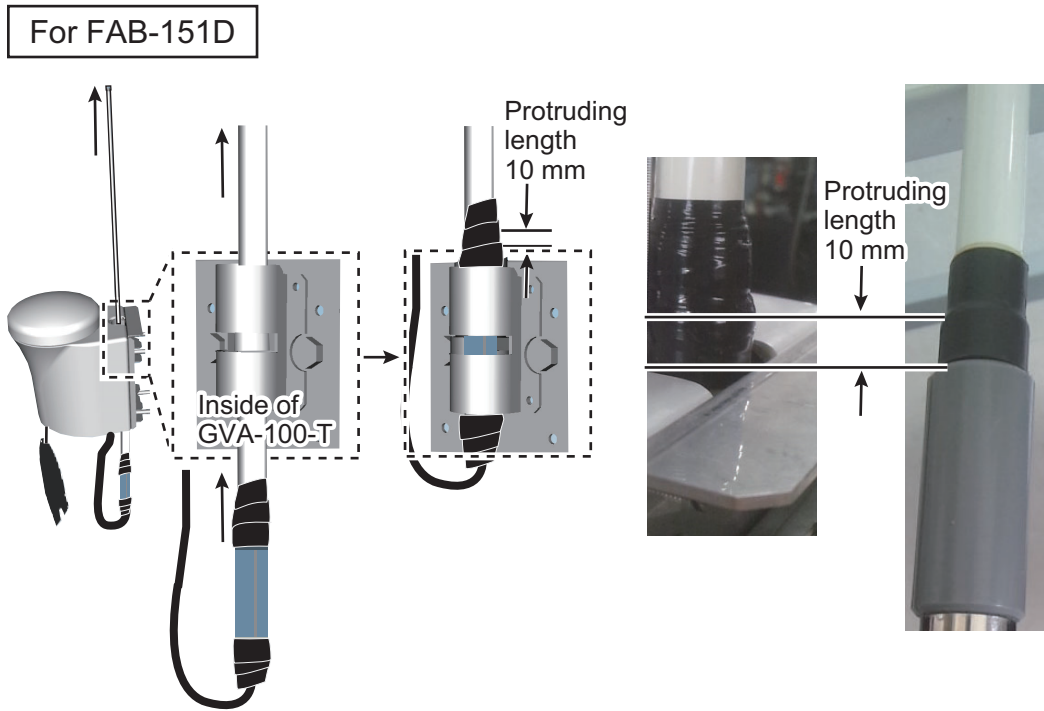

Correct installation



NG: PVC pipe can be seen.



NG: Taped part can not be seen.

7. Fasten the bottom cover to the GVA-100-T.

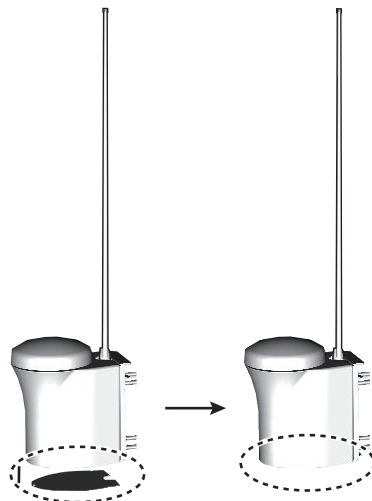

### **Mounting procedure**

1. Dismount the bottom cover, cut the cable-tie inside the unit and take out the coaxial connector attached to the combined box.
2. Loosen four screws to loosen whip antenna fixture and pull out the coaxial connector coming from the combined box through the hole in the whip antenna fixture.

3. Connect the coaxial connector to the whip antenna base and wrap the junction part of the whip antenna with vulcanizing tape and then vinyl tape for waterproofing.
4. Insert the whip antenna from the top of the combined antenna.
5. Secure the whip antenna with whip antenna fixture.
6. Using a new cable tie (supplied), secure the cables and coaxial connector inside the antenna case.
7. Mount the bottom cover.
8. Fix the GPS/VHF combined antenna to the ship's stanchion (40 to 50 mm diameter) with antenna fixing brackets, flat washers and hex nuts.

**Note:** Coat the exposed parts of bolts and nuts with marine sealant (local supply).

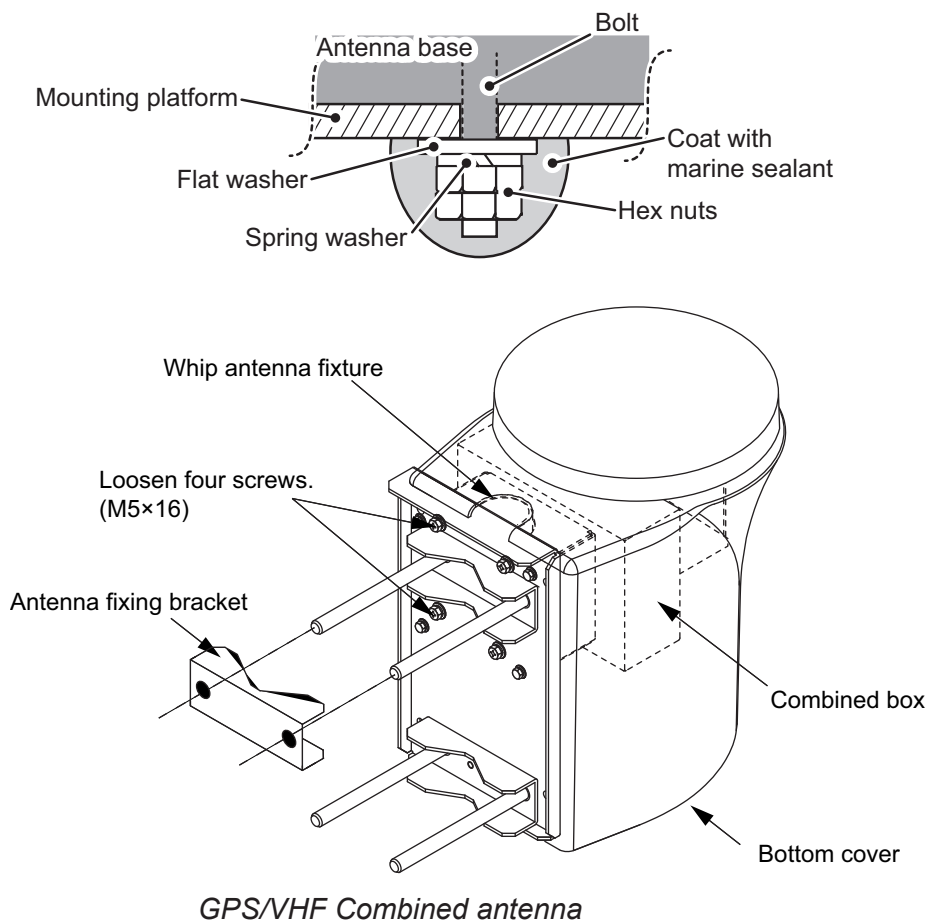

## 1. MOUNTING

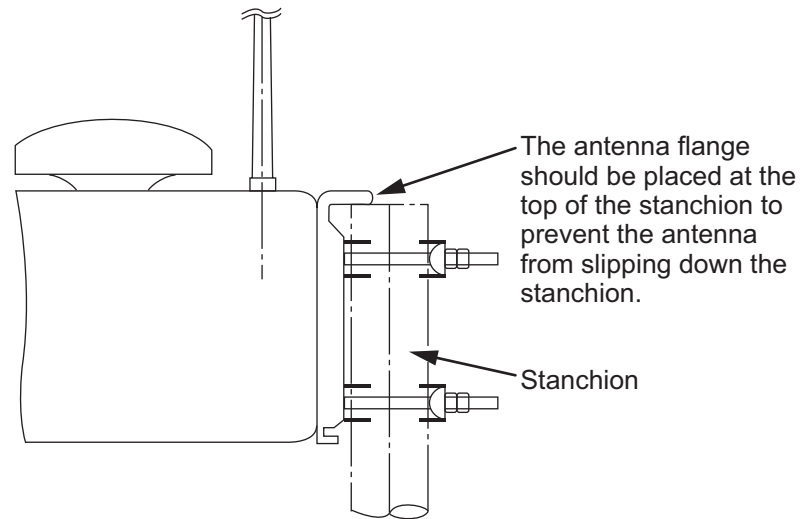

### **How to install distributor unit DB-1**

The length of the cable between the distributor unit and transponder unit is 1 m so locate the distributor unit within 1 m from the transponder unit. Fix the distributor unit on the bulkhead, facing the cable entrance downward. Remove the lid of the distributor unit and secure the unit with two self-tapping screws.

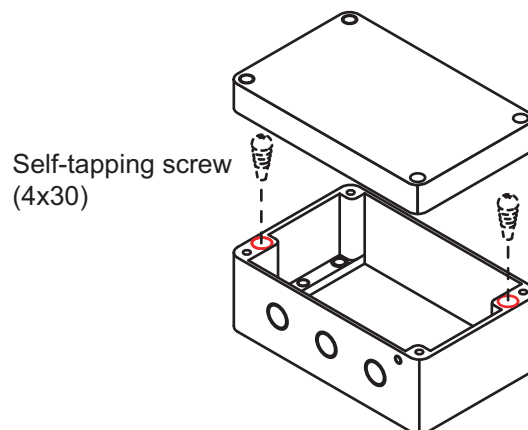

**Note:** Be sure no foreign material or water enters the distributor unit.

## **1.2 How to Install the FA-1702 Monitor Unit**

The monitor unit can be installed on a desktop, overhead (bulkhead) or flush mounted in a panel. Install it on the chart table or near the steering place, referring to the outline drawing.

When selecting a mounting location for the monitor unit, keep the following in mind:

- Keep the unit out of direct sunlight.
- The temperature and humidity should be moderate and stable. (Operating temperature range: -15°C to +55°C)
- Locate the unit away from exhaust pipes and vents.
- The mounting location should be well ventilated.
- Mount the unit where shock and vibration are minimal.



- Keep the unit away from electromagnetic field generating equipment such as motor, generator.
- For maintenance and checking purposes, leave sufficient space at the sides and rear of the unit and leave slack in cables. Refer to the outline drawing.
- A magnetic compass will be affected if the unit is placed too close to it. Observe the following compass safe distances to prevent disturbance to the magnetic compass:  
**Standard compass:** 0.65 meters  
**Steering compass:** 0.40 meters
- For flush mount installation, make sure the mounting location is flat.
- To avoid damage to the cabling when mounting the FA-1702, make sure the cabling is not excessively bent.

**Note:** The cabling to the FA-170 should be completed before mounting the unit. See "How to connect the FA-1702 monitor unit" on page 2-5.

### 1.2.1 How to fit the cable gasket (When using the OP05-146-1 or OP05-146-2)

When using the cable assembly OP05-146-1 or OP05-146-2, its waterproofing capability can be increased by attaching the cable gasket attached to the cable assembly.

The cable gasket needs to be attached to the cable as shown below. The cut line must face downward to prevent the water intrusion to the unit.

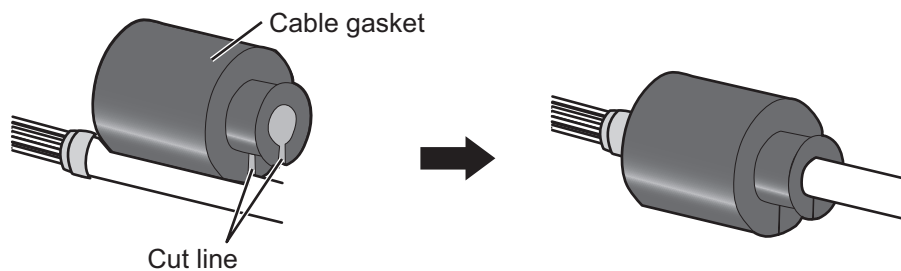

Regarding how to fit the cable gasket to the cable clamp, refer to the illustration on the next page, step 2.

Regarding how to connect the cabling to the FA-1702, referring to section 2.3.1.

## 1. MOUNTING

### 1.2.2 How to fit the optional waterproofing kit (OP05-139)

The optional waterproofing kit (OP05-139) must be fitted at the same time as the cabling is connected to the FA-1702.

The waterproofing kit (OP05-139) contains the following items:

- Cover gasket (Code:100-403-800-10) ×1
  - Cable gasket (Code:100-403-791-10) ×1
1. Unfasten the four screws on the rear cable clamp, then remove the cable clamp to reveal the WAGO connector.
  2. Fit the cable gasket to the cable clamp, referring to the figure below.

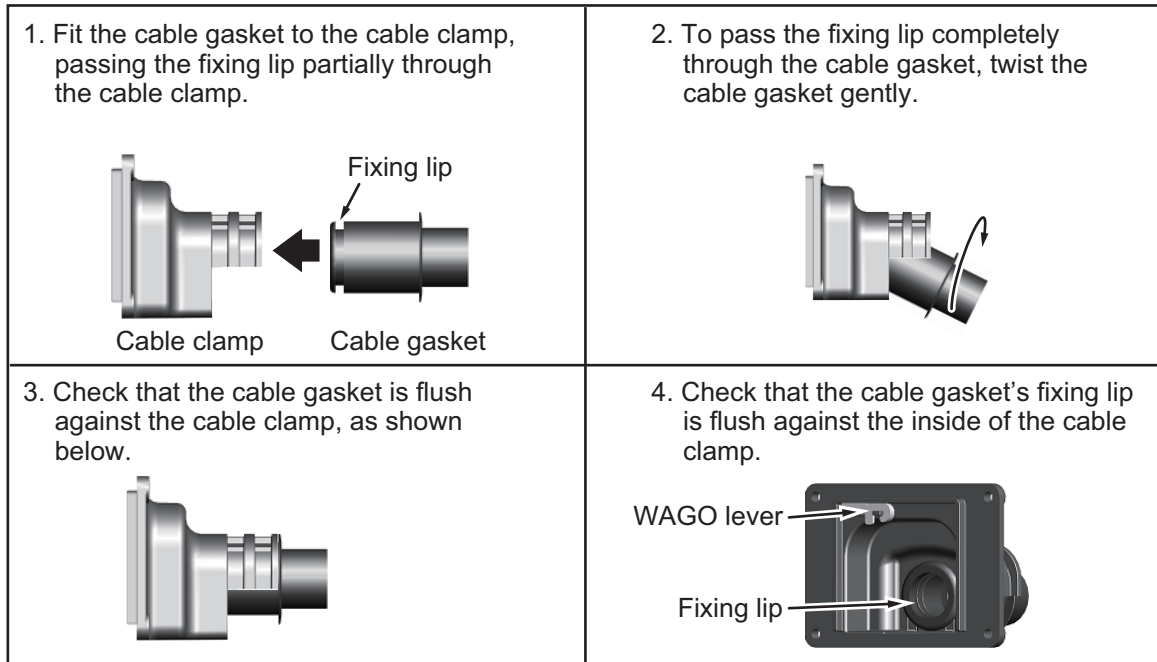

3. Pass the cabling through the cable gasket and cable clamp.  
**Note:** To maintain the IPx5 waterproof rating, the cable must be TTYCSLA-4 (or equivalent) with a diameter of  $\phi 14.4 \pm 0.4$  mm.
4. Fit the cover gasket to the rear of the FA-1702. Make sure the cover gasket is placed inside the groove indicated in the figure below.

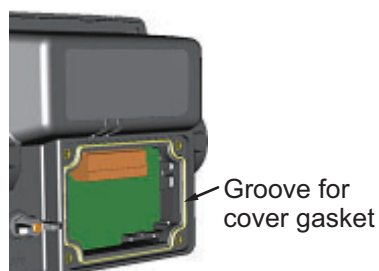

5. Connect the cabling to the FA-1702, referring to section 2.3.1.

- Slide the cable clamp along the cable until the clamp is flush against the rear of the FA-1702.

**Note:** The cable clamp must be oriented with the dome-side up, to prevent water intrusion.

- Fasten the four screws removed at step 1.
- Secure the cabling to the cable clamp with cable ties (included) referring to the figure in section 2.3.1.

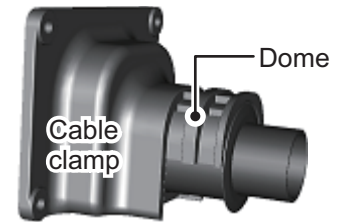

### 1.2.3 How to install the FA-1702 on a desktop or overhead

The monitor unit is shipped with the hanger. For correct installation, the monitor unit and the hanger need to be separated during the installation.

- Place the monitor unit on a firm, flat surface, then unfasten the two knobs on either side of the monitor unit to separate the monitor unit and a hanger.
- Drill four holes for the self-tapping screws ( $\phi 5 \times 20$ ) at the installation location.
- Secure the hanger to the desktop or overhead with four self-tapping screws ( $\phi 5 \times 20$ , installation material). The hanger should be oriented with the insertion slots facing forward. For mounting dimensions and required clearance, see the outline drawing at the back of this manual.

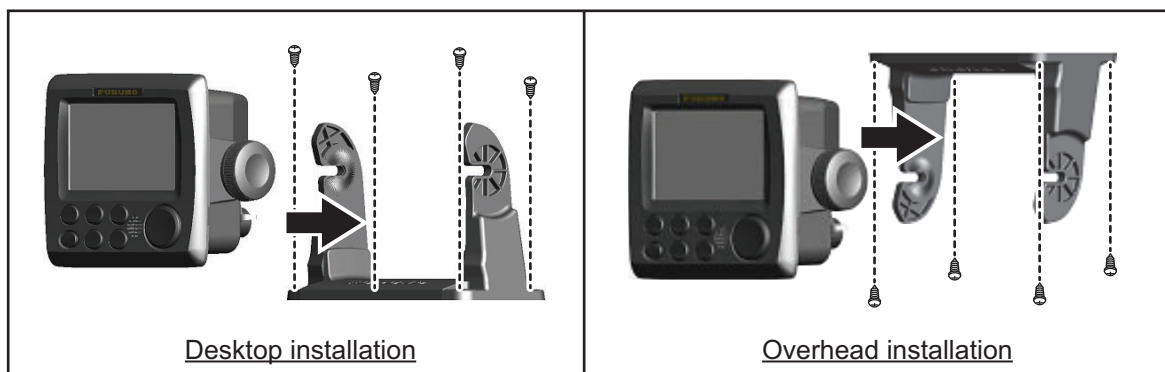

- Referring to section 2.3.1, connect the cabling to the monitor unit.
- Fit the monitor unit to the hanger and tighten the bolts on either side evenly. Adjust the angle of the monitor unit so that the screen can be viewed clearly.

### 1.2.4 How to flush mount the FA-1702

There are two methods for flush mounting the monitor unit, flush mounting the monitor unit directly to the installation location or with using the optional front fixing panel kit.

#### **Flush mounting the monitor unit (unit only)**

1. Cut a hole in the installation location, using the template at the back of this manual.
2. Drill four holes for the self-tapping screws ( $\phi 3 \times 20$ ).
3. Place the monitor unit on a firm, flat surface, then unfasten the two knobs on either side of the monitor unit to separate the monitor unit and a hanger. The hanger can be disposed.
4. Gently lift the locking tabs at the rear of the front panel, then the remove the front panel. Be careful not to damage the locking tabs or the front panel.

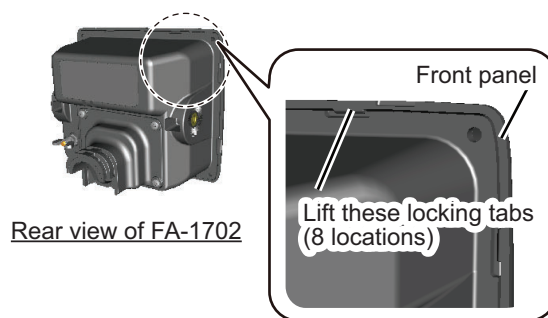

5. Fit the F Mount Cushion (20-032-106, installation material) to the rear of the monitor unit or to the installation hole.
6. Run the cabling through the cutout, then, referring to section 2.3.1, connect the necessary cabling to the FA-1702.

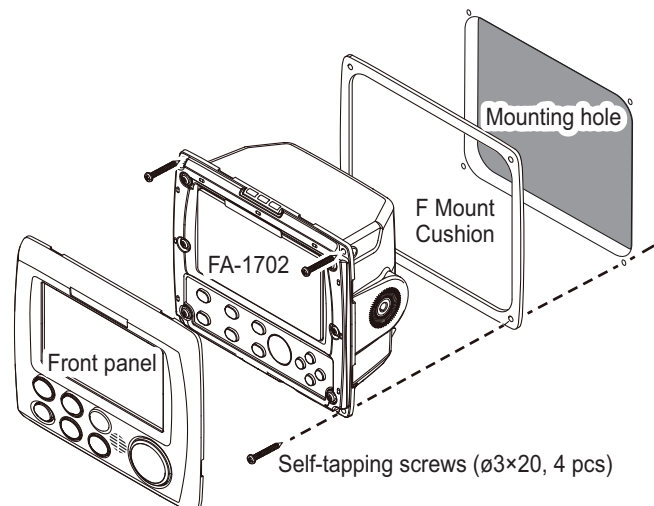

7. Referring to the figure above, fit the FA-1702 to the cutout, then use the supplied self-tapping screws ( $\phi 3 \times 20$ ) to secure the FA-1702 to the flush mount panel.

#### **Flush mounting the FA-1702 (with optional front fixing panel kit)**

Use the optional kit (OP24-35), referring to the outline drawings at the back of this manual and the installation instructions (C42-01310) included with the optional kit.

## 1.3 How to Install the FA-1701 Transponder Unit

Mount the transponder where it is protected from rain and water splash. This unit can be installed on a bulkhead, wall or on the floor. Install it referring to the outline drawing at the back of this manual for dimensions.

When selecting a mounting location for the transponder, keep the following in mind:

- Keep the transponder out of direct sunlight.
- The temperature and humidity should be moderate and stable.  
(Operating temperature range: -15°C to +55°C)
- Locate the unit away from exhaust pipes and vents.
- The mounting location should be well ventilated.
- Mount the unit where shock and vibration are minimal.
- Keep the unit away from electromagnetic field generating equipment such as motor, generator.
- For maintenance and checking purposes, leave sufficient space at the sides and rear of the unit and leave slack in cables. Refer to the outline drawing.
- A magnetic compass will be affected if the unit is placed too close to it. Observe the following compass safe distances to prevent disturbance to the magnetic compass:
  - Standard compass: 1.70 meters
  - Steering compass: 1.10 meters
- Avoid floor mounting the transponder in locations where there is water splash. Keep the cable entry away from water spray and splash.

### **Mounting**

1. Select a mounting location, referring to the recommendations listed above.
2. Referring to the outline drawing at the back of this manual, fit two self-tapping screws at the location for the bottom fixing holes. Leave approximately 5 mm of thread exposed.
3. Place the FA-1701 on the two screws.
4. Fasten two self-tapping screws to the top fixing holes.
5. Fasten all screws to secure the FA-1701.

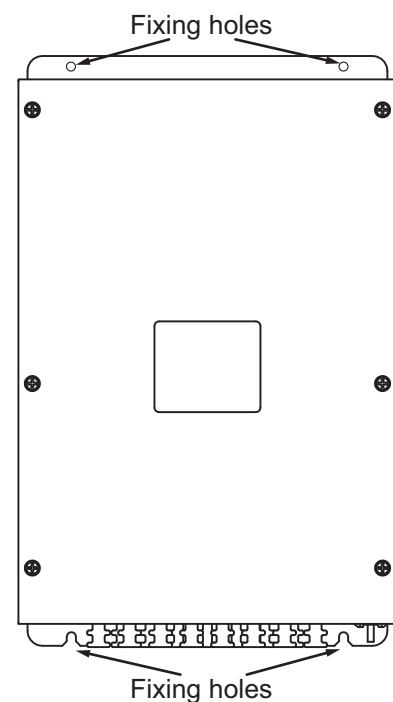

## 1.4 How to Install the FA-1703 Pilot Plug Unit (option)

The pilot plug unit is only available in the flushmount configuration and should be mounted near where the pilot steers the ship. This plug is used to connect a PC to display AIS information for use by the pilot.

1. Cut a mounting hole in the mounting location, referring to the outline drawing at the back of this manual for mounting dimensions.
2. Feed the necessary cables through the cutout, then referring to chapter 2, connect the pilot plug unit.
3. Set the pilot plug unit to the cutout. Use caution to prevent damage to cables when setting the pilot plug unit into the cutout.

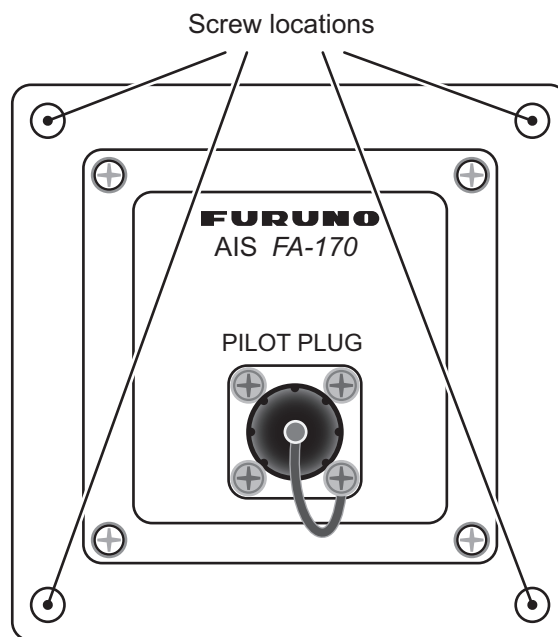
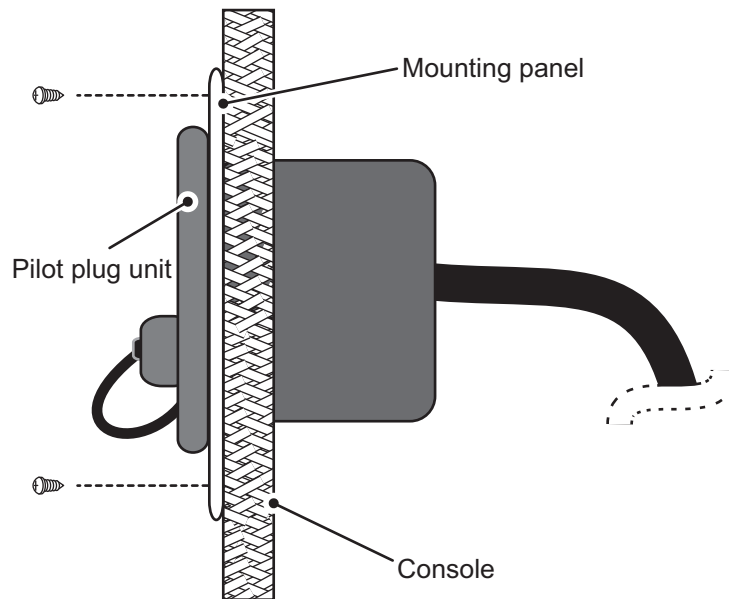

4. Secure the pilot plug unit in place with the supplied screws, referring to the figures above.

## 1.5 How to Install the PR-240 Power Supply (option)

When selecting a mounting location for the unit, keep the following in mind:

- Keep the unit away from areas subject to water splash.
- Locate the unit away from exhaust pipes and vents.
- The mounting location should be well ventilated.
- Mount the unit where shock and vibration are minimal.
- A magnetic compass will be affected if the unit is placed too close to it. Observe the following compass safe distances to prevent disturbance to the magnetic compass:

Standard compass: 0.90 meters

Steering compass: 0.60 meters

Fix the unit with four self-tapping screws (4×16) to a desktop or the deck as shown in the figure below. It is not necessary to open the cover.

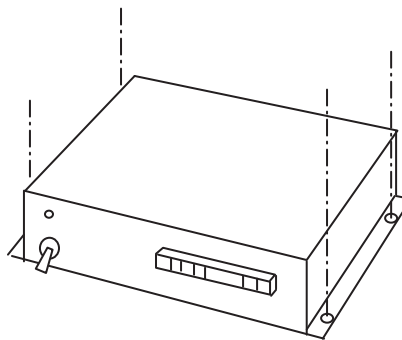

## 1. MOUNTING

This page is intentionally left blank.



# 2. WIRING

## 2.1 Connection Overview

Connect the equipment, referring to the interconnection diagram at the back of this manual.

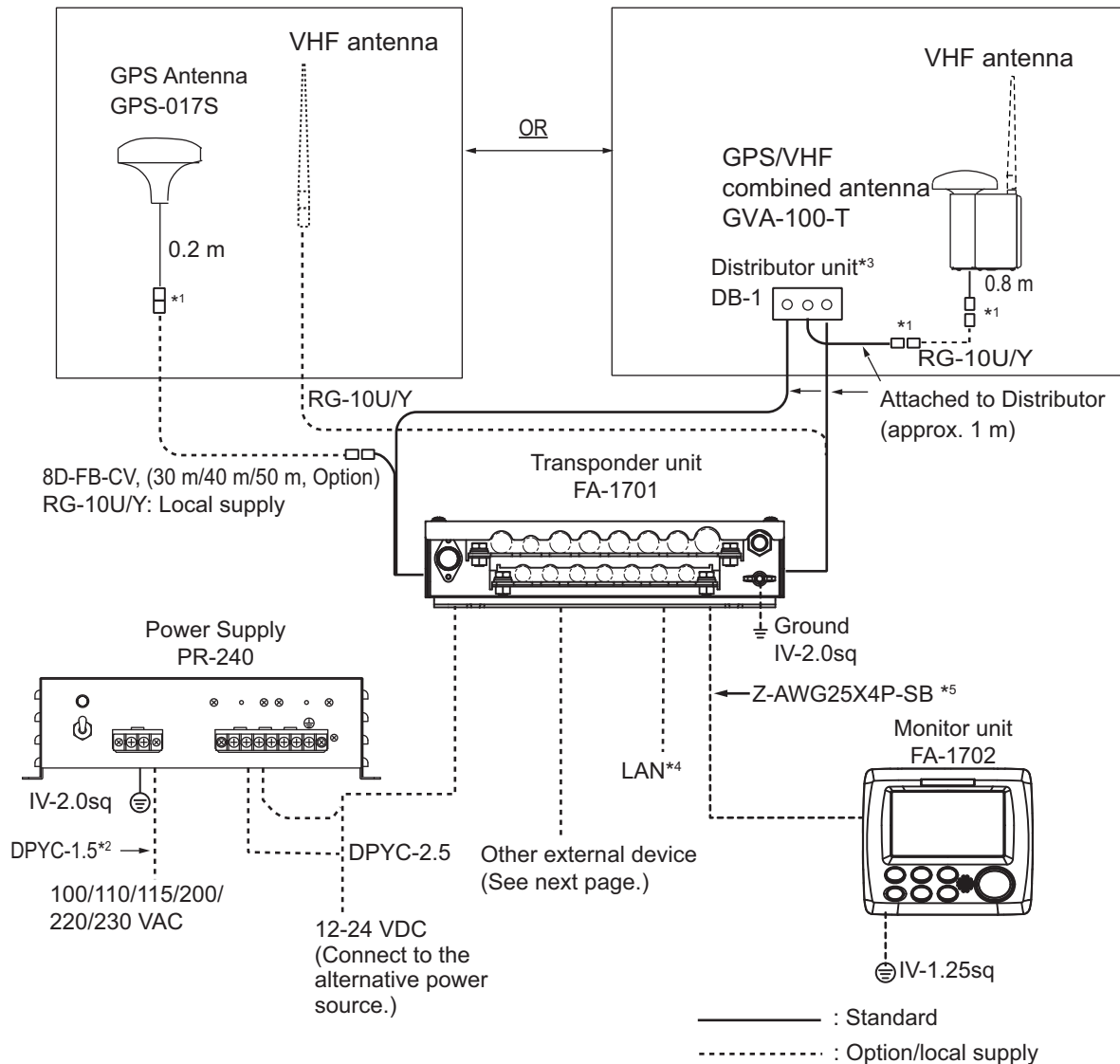

Power supply specifications	
Transponder Unit	12-24 VDC, 6-3 A
Monitor Unit	12 VDC, 0.3 A max.
AC/DC Power Supply Unit	100-115/200-230 VAC, 1 phase, 50/60 Hz

- \*1: Connections must be waterproofed. See "How to secure and waterproof exposed connections" on page 2-3.
- \*2: DPYC-2.5, TTYCSLA-1, TTYCSLA-1Q, TTYCSLA-4 and TTYCSLA-7 are Japan Industry Standard cables. Use them or the equivalents, referring to the "JIS CABLE GUIDE" on page AP-1.
- \*3: Ground is not required.
- \*4: When connecting the LAN cable, leave approx. 200 mm slack before clamping the cable at the cable clamps.
- \*5: Cable type varies depending on configuration. Z-AWG25X4P-SB cable may be substituted for TTYCSLA-4 type cable or locally supplied cable.

## 2.2 How to Fabricate the Cables

### LAN cable fabrication

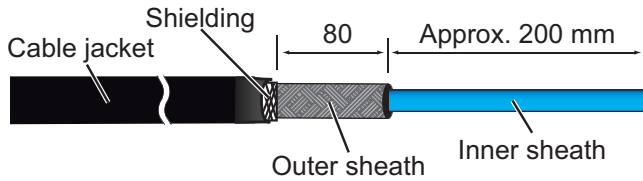

Expose the inner and outer sheaths as shown to the left.



Cover the cable jacket at the cut as shown to the left.

Cover the cable jacket with insulated tape (20 mm width)



Expose inner vinyl sheath.



Remove the outer sheath by approx 25 mm. Be careful not to damage inner shield and cores.

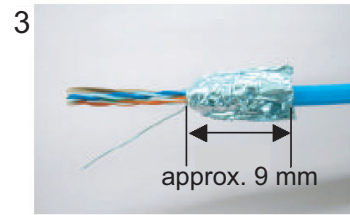

Fold back the shield, wrap it onto the outer sheath and cut it, leaving 9 mm.

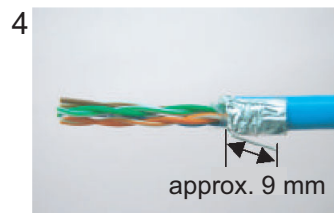

Fold back drain wire and cut it, leaving 9 mm.

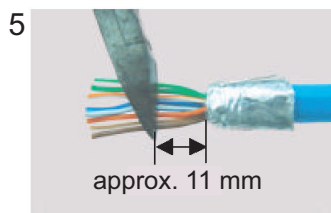

Straighten and flatten the cores in order then cut them, leaving 11 mm.

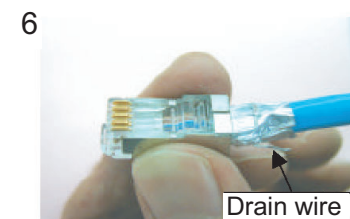

Insert the cable into the modular plug so that the folded part of the shield enters the modular plug. The drain wire must be on the tab side of the jack.



Using special crimping tool MPT5-8AS (PANDUIT CORP.), crimp the modular plug. Finally check the plug visually.

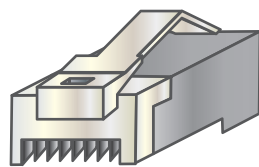

Modular plug

[Straight cable]

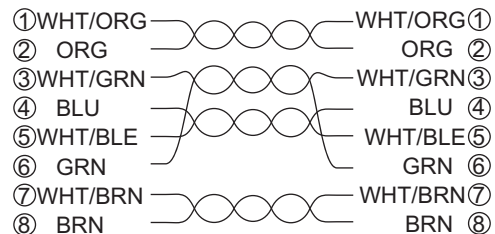

**Fabrication of cables TTYCSLA-4, TYCSLA-7, TTYCSLA-1Q and TTYCSLA-1**

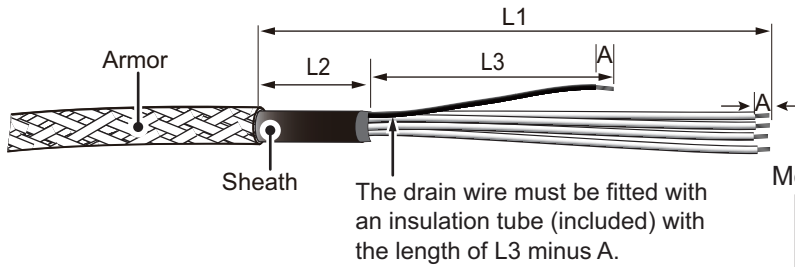

Measurements are displayed in mm

Unit	L1	L2	L3	A
FA-1701	*	80	80	6
FA-1702	130	80	60	6
FA-1703	170	100	80	9

Using the terminals supplied on the inside of the FA-1701, fit the drain wire of each TTYCSLA cable with a terminal, then attach the terminal to the inside of the FA-1701 (the same place it was situated originally).

\*: Length depends on installation configuration. When fabricating this cable, ensure enough slack is left to allow easy access for maintenance and service.

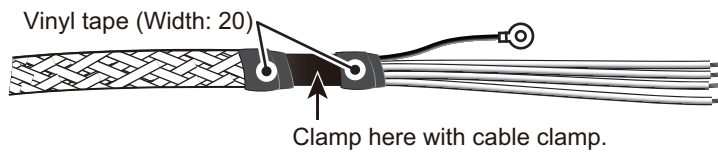

**Note:** L2 lengths displayed in the table above are the minimum recommended length. Adjust the length according to the installation configuration.

**Fabrication of power cable DPYC-2.5**

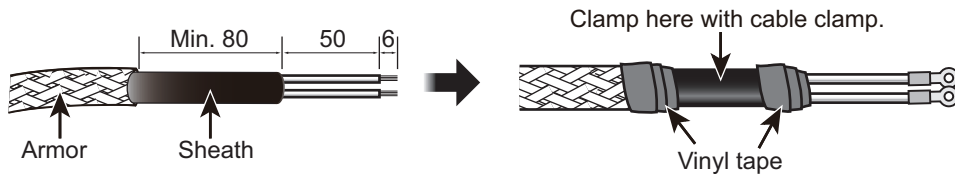

**2.2.1 How to secure and waterproof exposed connections**

All exposed connections between units should be secured and waterproofed using the procedure below.

- 1) Wrap the connection with self-vulcanizing tape.
- 2) Wrap a second layer of self-vulcanizing tape in the opposite direction.

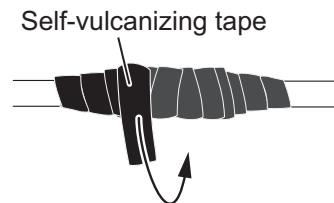
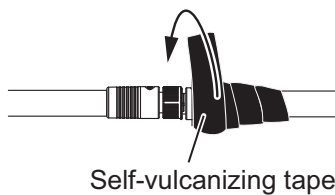

- 3) Wrap vinyl tape over the self-vulcanizing tape.
- 4) Wrap a second layer of vinyl tape in the opposite direction.

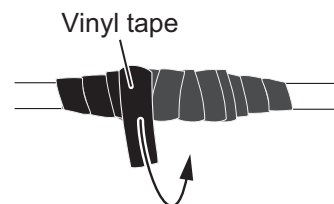
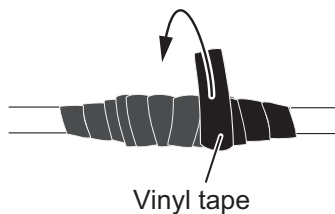

## 2.3 Unit Interconnection

The transponder unit (FA-1701), monitor unit (FA-1702) and the pilot plug unit (FA-1703) use different connectors for interconnection. See the figures below to fabricate the connections.

### How to attach wires to the connectors

Transponder unit FA-1701  
Terminal opener is located on rear of the FA-1701 cover.

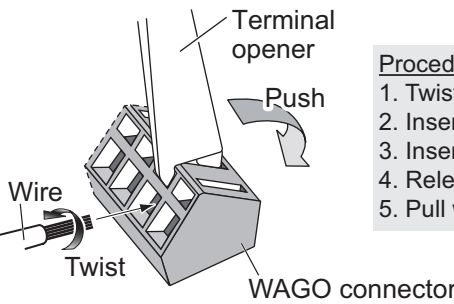

**Procedure**

1. Twist core.
2. Insert terminal opener and push.
3. Insert wire into hole. Be careful not to pinch the sheath.
4. Release terminal opener.
5. Pull wire to confirm it is correctly inserted.

Monitor unit FA-1702  
Terminal opener is located inside cable clamp (rear cover).

Push downward.

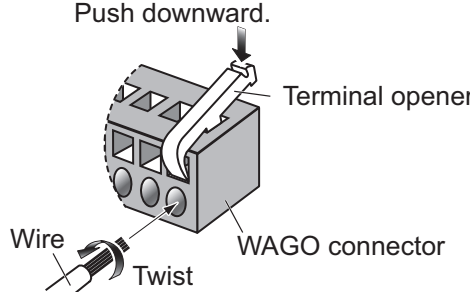

**Procedure**

1. Twist the cores.
2. Push the terminal opener downward.
3. Insert the wire to hole.
4. Remove the terminal opener.
5. Pull the wire to confirm that it is secure.

Pilot plug unit FA-1703  
Use a flat head screwdriver to open the terminals.

Push downward.

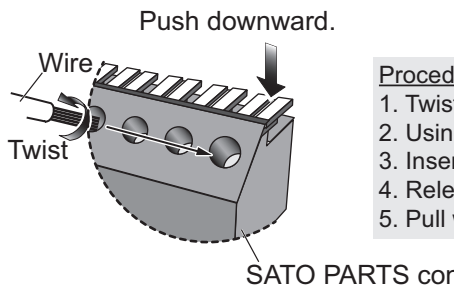

**Procedure**

1. Twist core.
2. Using a flat screw driver, push the terminal opener.
3. Insert wire into hole. Be careful not to pinch the sheath.
4. Release terminal opener.
5. Pull wire to confirm it is correctly inserted.

### 2.3.1 How to connect the FA-1702 monitor unit

1. Unfasten the four screws on the rear cable clamp, then remove the cable clamp to reveal the WAGO connector.

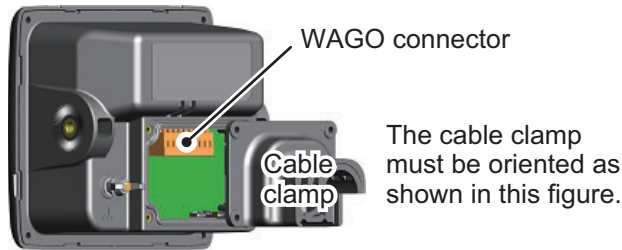

2. Unplug the WAGO connector from the FA-1702.
3. Pass the cable through the cable clamp.  
**Note:** To maintain the IPx5 waterproof rating, the cable must be TTYCSLA-4 (or equivalent) with a diameter of  $\phi 14.4 \pm 0.4$  mm.
4. Referring to the table below and the interconnection diagram at the back of this manual, connect the FA-1702 using the WAGO connector inside the unit.

WAGO Pin No.	Connection	WAGO Pin No.	Connection
1	P12V_P	6	TD-B
2	GND	7	RD-A
3	PON-H	8	RD-B
4	PON-C	9	Drain wire
5	TD-A		

5. Slide the cable clamp along the cable towards the FA-1702, then fasten the four screws which were removed at step 1. The cable clamp must be oriented as shown the figure above.
6. Secure the cable to the cable clamp with cable tie(s) (included). The location and number of cable tie(s) is different, depending on whether the cable assembly OP05-146-1, OP05-146-2, optional cable protection kit or waterproofing kit is installed. Refer to the figure below for the correct location and numbers.

Top view of cable clamp

When using the cable assembly OP05-146-1, OP05-146-2 or the cable protection kit (OP05-147)	When using the cable (TTYCSLA-4)	
	Without using the waterproofing kit (OP05-139)	With using the waterproofing kit (OP05-139)
With three cable ties	With two cable ties	With a single cable tie
<p>Secure the cable gasket also with a cable tie.</p>	<p>Wind cable ties through the slots.</p>	<p>Wind a cable tie outside of the cable clamp.</p>

## 2. WIRING

In cases where the WAGO connector is connected to the cable before the cable is passed through the cable clamp, the cable clamp can be adjusted to allow connection.

**Note:** Adjusting the cable clamp as outlined in the figure below voids the IPx5 waterproof rating of the clamp and the unit. To keep the IPx5 rating, remove the WAGO connector, then repeat the procedure above. When the following adjustment is done, the protection rating will be IPx2 even if any cable gasket is used.

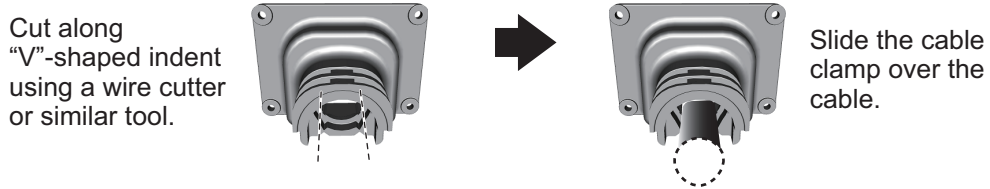

### 2.3.2 How to connect the FA-1701 transponder unit

Referring to the figure and table below, connect the FA-1701. The figure below also shows the recommended entry point for connected cables. (Based on a vessel configured to use all WAGO connection points.)

The WAGO connection points are individually marked on the TRX-PWR PC board.

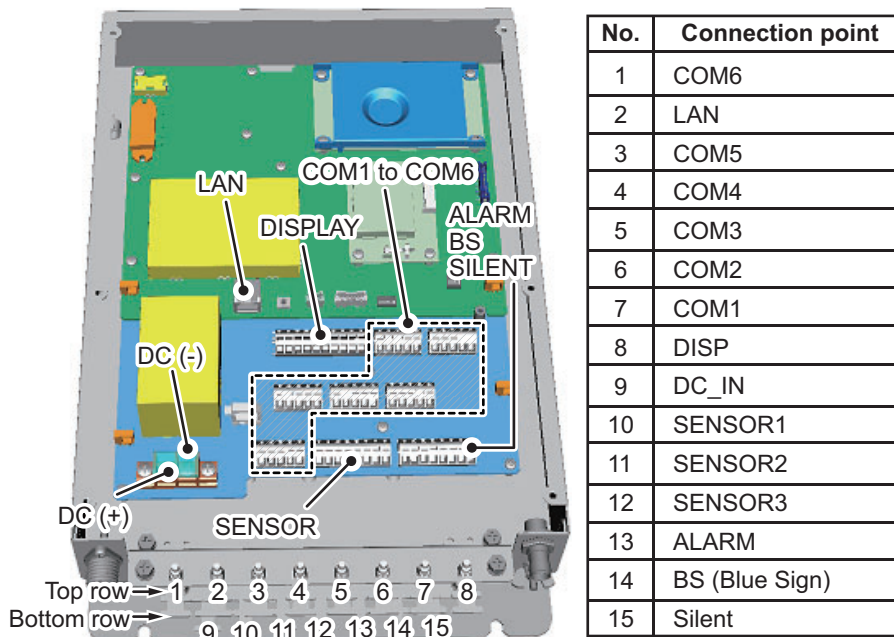

Cable entry #8 should be used for DISP cabling, regardless of vessel configuration, as the entry hole is larger than the other entry points.

Cable entry #2 should be used for LAN connection, regardless of vessel configuration, to avoid excess stress on the LAN cable.

Port	Description
COM1 to COM3	Long range communication device (Inmarsat C, etc.) or External display (Radar, ECDIS, NavNet 2, NavNet 3D), BEACON or Pilot Plug Unit
COM4 to COM6	Long range communication device (Inmarsat C, etc.) or External display (Radar, ECDIS, NavNet 2, NavNet 3D), Pilot Plug Unit, BEACON or Sensor (GPS, Gyrocompass, Speed log, ROT)
DISPLAY	Connects to Monitor Unit FA-1702.
ALARM	Connects to on-board alarm system.

Port	Description
BS (Blue Sign)	Connects a Blue Sign device, a lighting device mounted on the bridge which gives off a blue light to warn oncoming vessels when the vessel is navigating a channel in the reverse direction.
SENSOR	GPS, Gyrocompass, Speed log, ROT.

**Note 1:** The cable entry points (for the top row only) are protected from foreign material with small plastic spacers. Remove the spacers as required when connecting cables to the FA-1701.

All cables should be secured at the cable clamps (indicated as #1 through #15 in the figure above) using cable ties (included). The LAN cable in particular should be secured with the outer sheath of the LAN cable on the cable clamp.

### 2.3.3 How to connect the FA-1703 (Pilot Plug Unit, optional)

The FA-1703 is shipped with a flushmount panel attached. The flushmount panel can be removed if it is not required.

The example figures below show the FA-1703 without a flushmount panel.

1. Unfasten the four screws at the locations indicated with arrows in the figure below.

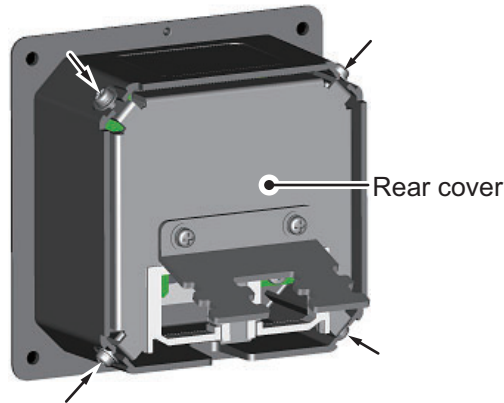

2. Remove the rear cover of the FA-1703. The 05P0895 board, with three SATO PARTS connectors, is exposed.

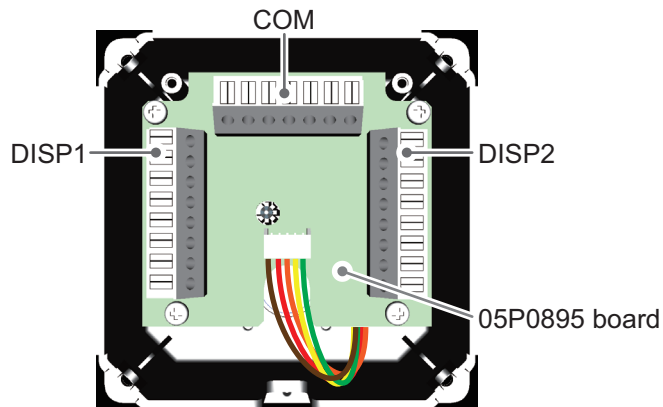

3. Referring to "Unit Interconnection" on page 2-4 and the interconnection diagram at the rear of this manual, connect the FA-1703.
4. Pass the connected cables through the locking wire saddle on the rear cover, then fit the rear cover to the FA-1703.

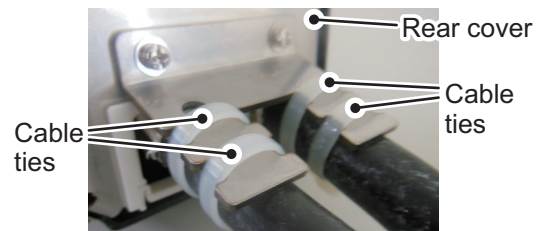
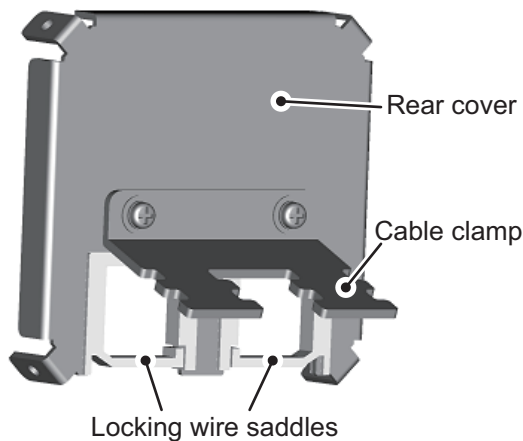

5. Fasten the four screws removed at step 1, then secure the connected cables to the cable clamp with cable ties.



## 2.4 How to Terminate COM Ports (For IEC 61162-1/2 signal)

When the output/input signal used is IEC61162-2 format, terminate at the DIP switch (S2, S3) as required. The DIP switch is located on the TRX-PWR board, see the figure below.

**Note 1:** Incorrect termination may cause communication errors.

**Note 2:** The factory default setting DIP switch S2 and S3 are shown in the figure below.

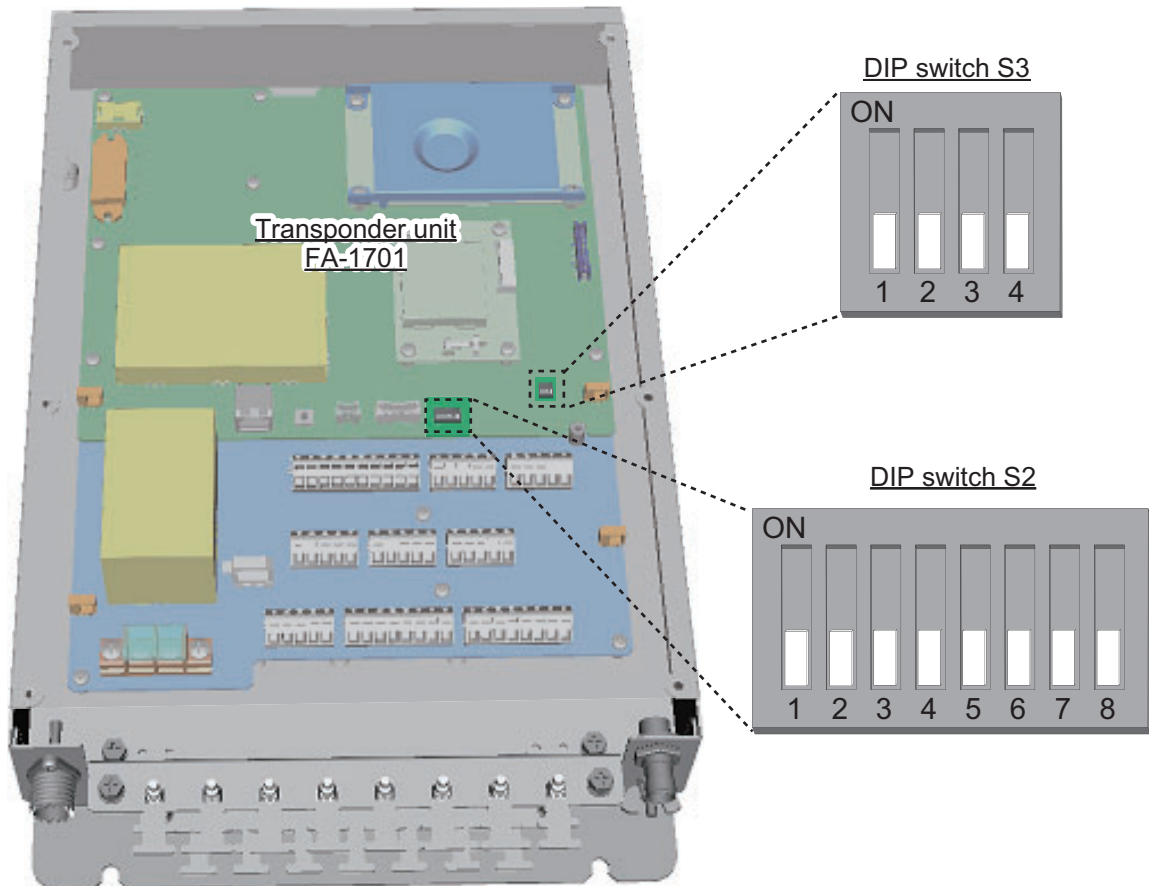

COM port	Termination
COM1	Set S2 #1 to ON.
COM2	Set S2 #2 to ON.

**Note:** S2 #3 to #8 are for technical personnel only. Do not change these settings.

COM port	Termination
COM3	Set S3 #1 to ON.
COM4	Set S3 #2 to ON.
COM5	Set S3 #3 to ON.
COM6	Set S3 #4 to ON.

**Note:** When using the COM ports as IEC61162-1, termination must be OFF.

Where the FA-1701 is part of a daisy chain, and is not the last unit in the daisy chain, the DIP switch for the daisy chained COM port must be OFF. Where the FA-1701 is the last unit in the daisy chain, do not change the DIP switch settings.

## 2.5 How to Change the Ship's Mains Specifications

The AC-DC power supply PR-240 is shipped ready for connection to a 200-230 VAC ship's mains. If the ship's mains is 100 VAC-115 VAC, change the tap connection and terminal board connection as below. Attach label supplied as accessories to the front panel according to the ship's mains.

Ship's mains	Tap connection	Terminal board	Label
200-230 VAC	SEL 230 V	Below (a)	200-230 VAC 2.5-2.0 A 1 $\phi$ , 50/60 Hz
100-115 VAC	SEL 115 V	Below (b)	100-115 VAC 4.0-3.5 A 1 $\phi$ , 50/60 Hz

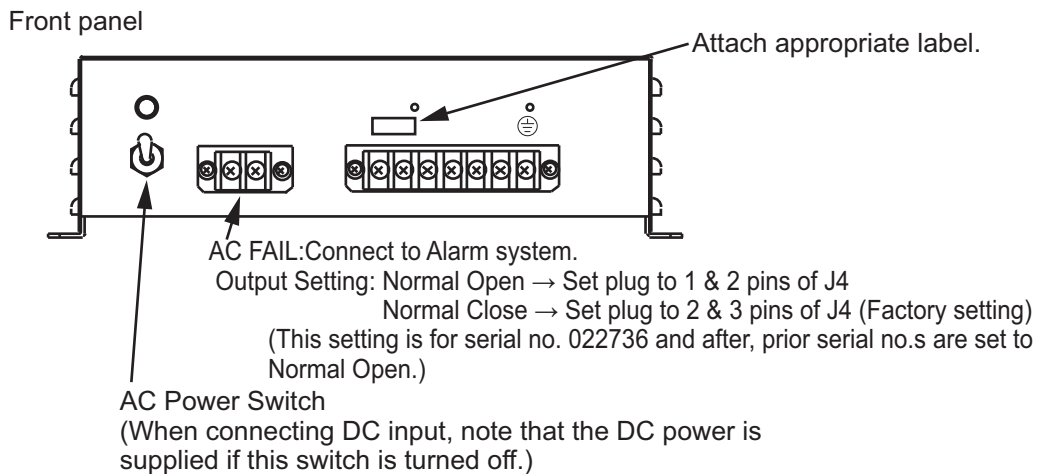
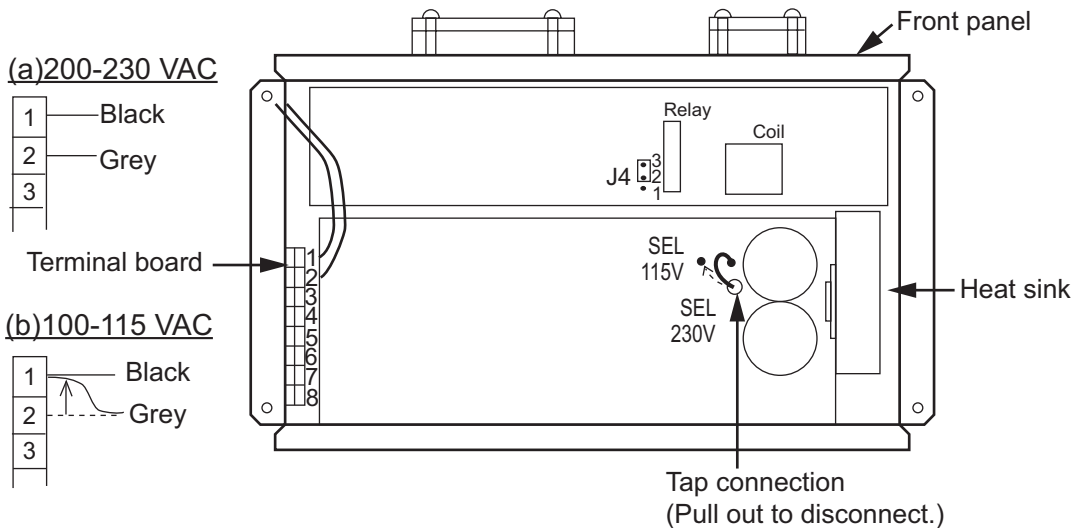
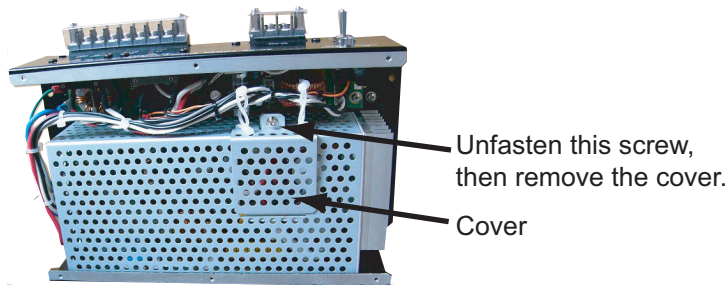

**Note:** The DC output load must be less than 8A.

# 3. SETTINGS AND ADJUSTMENTS

After installing the equipment, set up the own ship's static information (MMSI, IMO number, ship's name, call sign, type of ship and GPS antenna position). Also, set up the I/O ports.

## How to access the [INITIAL SET] menu

The [INITIAL SET] menu can be accessed at any time, however settings are password-locked and require a qualified technician or dealer for password input.

1. Press the **MENU/ESC** key to open the menu.

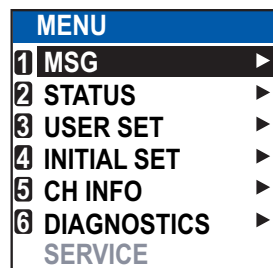

2. Select [INITIAL SET], then press the **ENT/ACK** key.
3. Select [EDIT], then press the **ENT/ACK** key. A pop up options window is displayed.

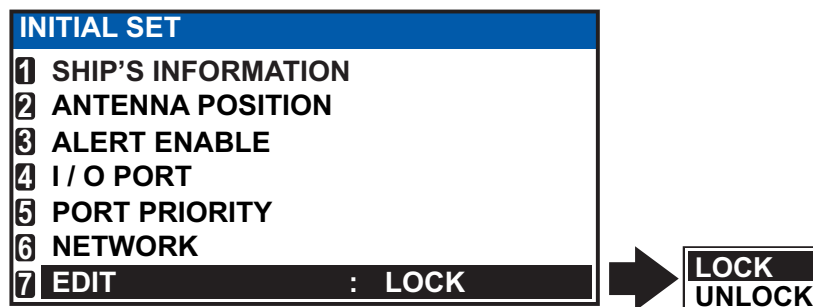

4. Select [UNLOCK], then press the **ENT/ACK** key. The password entry screen is displayed.

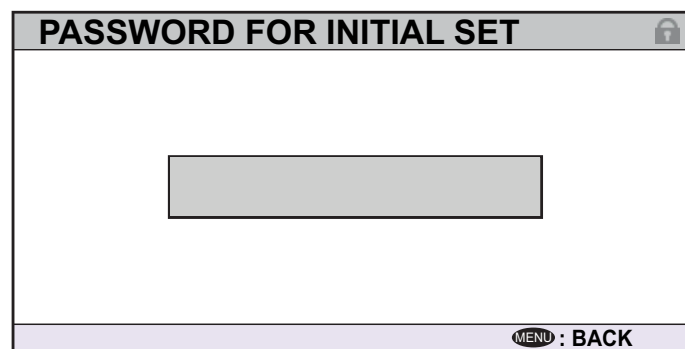

5. Input the password, then press the **ENT/ACK** key.

If the password is correct, the indication for [EDIT] reads "UNLOCK" and the [INITIAL SET] menu items can be edited. The lock icon, found on all settings screens, also changes to a blue colored open lock icon.

### 3.1 How to Set MMSI, IMO No., Name and Call Sign

This section covers the basic setup for CLASS A AIS systems. Inland AIS systems require several Inland AIS specific settings, outlined in section 3.2.

1. Access the [INITIAL SET] menu, following the procedure outlined in "How to access the [INITIAL SET] menu" on page 3-1.
2. Select [SHIP'S INFORMATION], then press the **ENT/ACK** key.
3. Select [MMSI], then press the **ENT/ACK** key to display the [MMSI] pop up window.

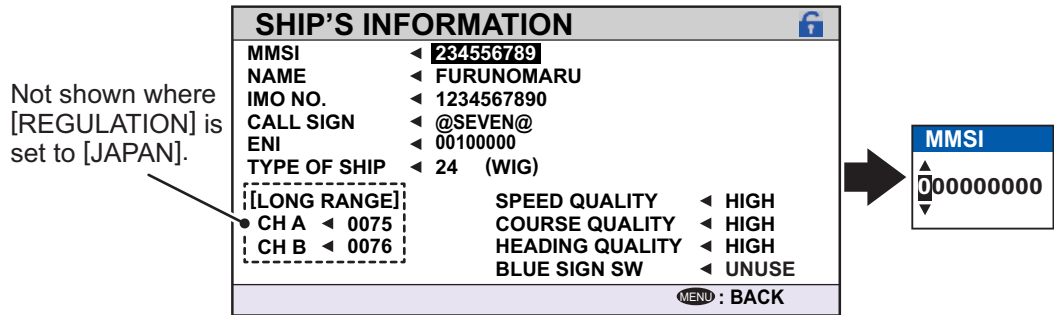

**Note:** [ENI], [SPEED QUALITY], [COURSE QUALITY], [HEADING QUALITY] and [BLUE SIGN SW] are Inland AIS settings. These items do not appear for other AIS modes. For Inland AIS settings, see section 3.2.

4. Use the arrow keys to set the [MMSI], then press the **ENT/ACK** key. The characters are cycled in the following order when ▲ is pressed: 1, 2 ... 9, 0, 1, 2... press ▼ to cycle through characters in the opposite direction. Press ► or ◀ to move the selection cursor.
5. Input the IMO number in a similar manner to MMSI.  
**IMO:** Ten digits. If the IMO number has 8 digits, enter "0" twice followed by IMO number. If the ship has no IMO number, enter ten zeros. Inland AIS is fixed at "0".
6. For [NAME] and [CALL SIGN], the software keyboard is displayed when the item is selected.

Cursor position is shown as a blue bar.

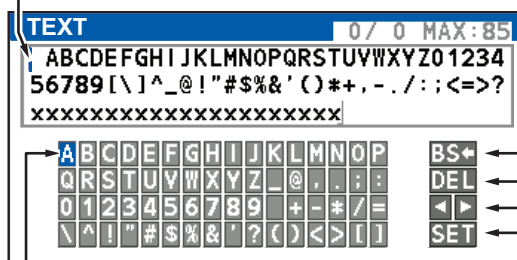

Current selection is highlighted in blue.

**Keyboard operation keys**

- Backspace** - Erase the character to the left of the cursor.
- Delete** - Erase the character to the right of the cursor.
- Cursor locators** - Press ► to move the cursor rightward, ◀ to move the cursor leftward.
- SET** - Apply the changes.

- 1) Referring to the figure above, press the arrow keys to select a character or keyboard operation.
- 2) Press the **ENT/ACK** key to confirm your selection.
- 3) Repeat steps 1 and 2 to complete the alphanumeric input.
- 4) Select [SET], then press the **ENT/ACK** key.
7. Select [TYPE OF SHIP] referring to section 1.5 of the operator's manual, then press the **ENT/ACK** key. This item is not available in Inland mode.
8. After entering data, press the **DISP** key to close the menu.

**Note:** If you enter incorrect data, do the procedure from step 1.

## 3.2 Inland AIS Specific Settings

This section shows how to activate and set up the Inland AIS feature. The AIS activation key is obtained from the place of purchase.

### 3.2.1 How to activate the Inland AIS

Input your key number (received from dealer) to activate the Inland AIS.

1. Press the **MENU/ESC** key to open the menu.

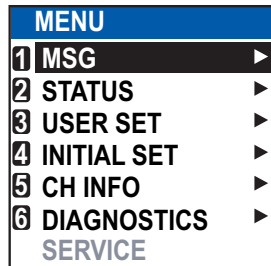

2. Select [USER SET] then press the **ENT/ACK** key.

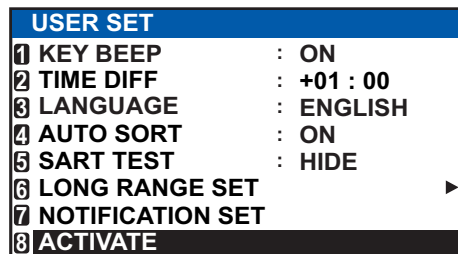

3. Select [ACTIVATE] then press the **ENT/ACK** key.

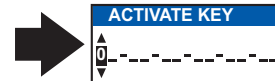
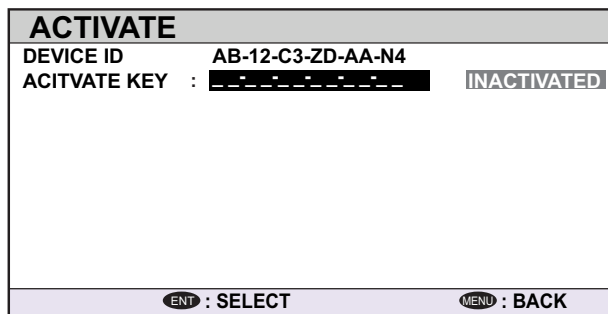

4. Press the **ENT/ACK** key to display the alphanumeric pop up window.  
The characters are cycled in the following order when ▲ is pressed: 1, 2 ... 8, 9, A, B, C ... X, Y, Z, 1, 2... press ▼ to cycle through characters in the opposite direction. Press ▶ or ◀ to move the selection cursor.
5. Input the activation key, then press the **ENT/ACK** key.

If you entered the activation key correctly, the indication "ACTIVATED. SYSTEM WILL RESTART" appears then the system is automatically restarted.

### 3.2.2 How to set blue sign status

Blue sign (a day-sign), which in combination with a white flashing light, must be shown if you are sailing on the port-side shore (against traffic direction).

1. Access the INITIAL SET menu, following the procedure outlined in "How to access the [INITIAL SET] menu" on page 3-1.
2. Select [SHIP'S INFORMATION] then press the **ENT/ACK** key.  
**Note:** [SHIP TYPE] is not displayed and the [IMO NO.] for your vessel is displayed as "0" when using [INLAND] mode.
3. Select [BLUE SIGN SW], then press the **ENT/ACK** key. A pop up options window is displayed.

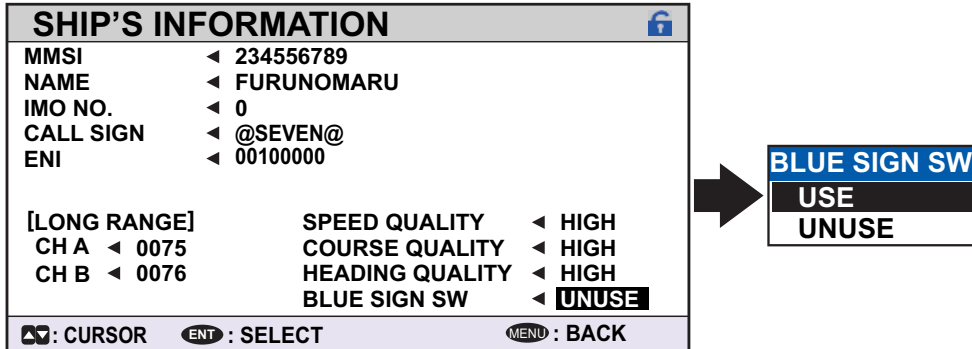

4. Select [UNUSE] (not in use) or [USE] (in use) as applicable, then press the **ENT/ACK** key.

### 3.2.3 Other inland AIS specific settings

Inland AIS requires the following additional settings:

#### ENI

1. Select [ENI], then press the **ENT/ACK** key to display the [ENI] pop up window.
2. Use the arrow keys to set the [ENI], then press the **ENT/ACK** key. The characters are cycled in the following order when ▲ is pressed: 1, 2 ... 9, 0, 1, 2... press ▼ to cycle through characters in the opposite direction. Press ► or ◀ to move the selection cursor.

#### Sensor quality

Set [SPEED QUALITY], [COURSE QUALITY] and [HEADING QUALITY] as follows:

1. Select [SPEED QUALITY], then press the **ENT/ACK** key to display the [SENSOR QUALITY (SPEED)] pop up window.
2. Select the [HIGH] or [LOW] as appropriate, then press the **ENT/ACK** key.  
Select [HIGH] where there is three or more referenced sensors, giving a higher quality reading.  
Select [LOW] where there is only one or two sensors, giving a reading which may require periodic adjustment.
3. Set [COURSE QUALITY] and [HEADING QUALITY] in the same manner.

### 3.3 How to Set GPS Antenna Position

Set the antenna position using this procedure. For INLAND AIS users, this procedure must be done in both INLAND mode and SOLAS mode.

1. Access the [INITIAL SET] menu, following the procedure outlined in "How to access the [INITIAL SET] menu" on page 3-1.
2. Select [ANTENNA POSITION], then press the **ENT/ACK** key. The settings screen for [ANTENNA POSITION] is displayed.

ANTENNA POSITION		
[SHIP SIZE]	LENGTH	BEAM
:	0m	0m
[ANT POSN]	Y	X
1 INTERNAL :	0m	0m
2 EXTERNAL :	0m	0m
[ANT POSN]	↕ A,B ↕	↔ C,D ↔
1 INTERNAL ◀	00,00	00,00
2 EXTERNAL ◀	00,00	00,00
⏏ : CURSOR    ENT : SELECT    MENU : BACK		

3. The [LENGTH] option is selected, press the **ENT/ACK** key to input the vessel length. The available range for length is 0 m to 800 m. Press the **ENT/ACK** key to apply the setting.
4. Select [BEAM], then press the **ENT/ACK** key to input the vessel beam. The available range for beam is 0 m to 100 m. Press the **ENT/ACK** key to apply the setting.

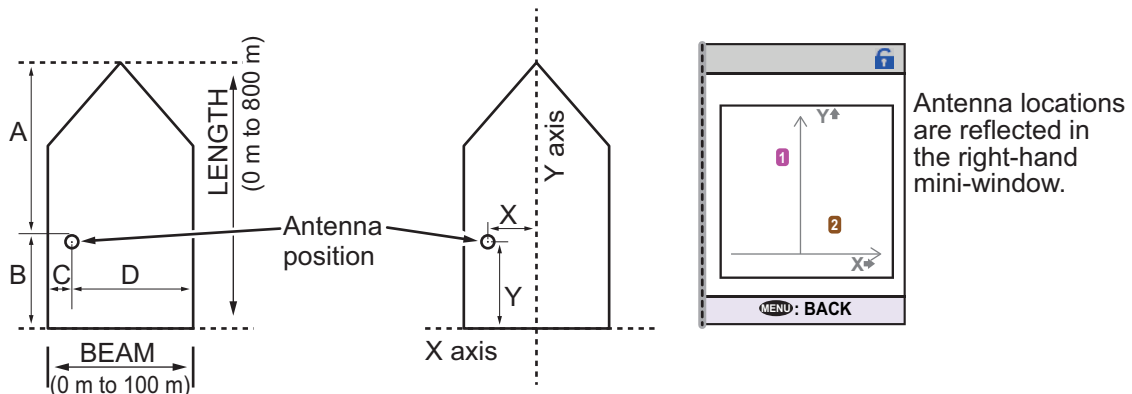

5. Select the Y indication for the internal antenna, then press the **ENT/ACK** key. A settings pop up window is displayed. The pop up shows the available setting range at the bottom. The Y axis coordinates are calculated from the stern of the vessel. The setting range varies depending on the vessel's dimensions.
6. Set the bow-stern position for the antenna, then press the **ENT/ACK** key.
7. Select the X indication for internal antenna, then press the **ENT/ACK** key. The X coordinates are calculated from the center of the vessel. Negative settings give a port-side positioning, positive settings give a starboard-side positioning.
8. Set the port-starboard position for the antenna, then press the **ENT/ACK** key.
9. Set the position for the external antenna, then press the **ENT/ACK** key. A settings pop up window is displayed. The pop up shows the available setting range at the bottom.

**Note:** The settings for the antenna position are reflected at the bottom of the screen, in gray, as [A,B] for bow-stern positioning and [C,D] for port-starboard positioning, and the antenna numbers are also shown in the right-hand mini-window.

10. Press the **MENU/ESC** key to return to the [INITIAL SET] menu.

### 3.4 How to Enable or Disable Alerts

You can enable or disable alerts from the [ALERT ENABLE] menu. Disabling an alert in this menu will disable all related alerts for the disabled alert.

**Note:** All alerts are set to [ENABLE] by default.

1. Access the [INITIAL SET] menu, following the procedure outlined in "How to access the [INITIAL SET] menu" on page 3-1.
2. Select [ALERT ENABLE], then press the **ENT/ACK** key.

The screenshot shows the 'ALERT ENABLE' menu with the following data:

WARNING1		WARNING2	
ENABLE: 8	DISABLE: 0	ENABLE: 9	DISABLE: 0
001	014	005	011
002	026	007	025
003	029	008	032
004	030	009	035
		010	

Selected alert's details: 001 : TX MALFUNCTION

Control buttons: CURSOR, ENT: ENABLE/DISABLE, MENU: BACK

Annotations: 'Cursor selection is highlighted' points to the 001 cell. 'Selected alert's details' points to the 001 : TX MALFUNCTION line. 'Disabled alerts are displayed in gray.' points to the 030 cell.

Active/unacknowledged alerts are displayed with an alert icon next to the alert ID.

3. Select an alert, then press the **ENT/ACK** key to enable or disable the alert. Enabled alerts are displayed in green color text, disabled alerts are displayed in gray color text.
4. Press the **MENU/ESC** key to return to the [INITIAL SET] menu.



## 3.5 How to Set Up the I/O Ports

1. Access the [INITIAL SET] menu, following the procedure outlined in "How to access the [INITIAL SET] menu" on page 3-1.
2. Select [I/O PORT], then press the **ENT/ACK** key.

I / O PORT		
PORT	MODE	SPEED
COM1	: EXT DISPLAY	38400baud
COM2	: EXT DISPLAY	38400baud
COM3	: EXT DISPLAY	38400baud
COM4	: EXT DISPLAY	38400baud
COM5	: EXT DISPLAY	38400baud
COM6	: EXT DISPLAY	38400baud
SENSOR1	: SENSOR	4800baud
SENSOR2	: SENSOR	4800baud
SENSOR3	: SENSOR	4800baud

: CURSOR    : SELECT    : BACK

**Note:** The figure above shows the default settings for all ports. The available port settings are outlined in the table on the following page.

PORT	MODE	SPEED (baud)
COM1	EXT DISPLAY	4800, 38400
	LONG RANGE	4800, 38400
	BEACON	4800
	MONITOR	57600
	DISABLE	-
COM2 to COM3	Same as COM1.	Same as COM1.
COM4	EXT DISPLAY	4800, 38400
	LONG RANGE	4800, 38400
	SENSOR	4800, 38400
	BEACON	4800
	MONITOR	57600
DISABLE	-	
COM5 to COM6	Same as COM4.	Same as COM4.
SENSOR1	SENSOR	Fixed at 4800
	DISABLE	-
SENSOR2 & SENSOR3	Same as SENSOR1.	Same as SENSOR1.

**Note 1:** When [MODE] is set to [BEACON] or [MONITOR], speed settings are fixed at the default setting.

**Note 2:** For detailed information on data format and related speeds, see "DIGITAL INTERFACE" on page AP-2.

### Mode definitions



MODE	Definition
EXT DISPLAY	External display (Radar, ECDIS, Pilot plug, etc.).
LONG RANGE	Long range communication device (Inmarsat C, etc.).
SENSOR	GPS, Gyrocompass, ROT, etc.
MONITOR	For FA-1702 Monitor Unit.
BEACON	For Beacon Receiver.
DISABLE	Disable the port.

### 3.5.1 How to set port priority

1. Access the [INITIAL SET] menu, following the procedure outlined in "How to access the [INITIAL SET] menu" on page 3-1.
2. Select [PORT PRIORITY], then press the **ENT/ACK** key.

Selected item is highlighted in reverse video.

PORT PRIORITY 			
PRIORITY	LL/COG/COG	HDG	ROT
1st	SENSOR1	SENSOR3	SENSOR3
2nd	SENSOR2	SENSOR1	SENSOR1
3rd	SENSOR3	SENSOR2	SENSOR2
4th	COM4	COM6	COM6
5th	COM5	COM4	COM4
6th	COM6	COM5	COM5
7th	LAN	LAN	LAN

 : CURSOR    : SELECT    : BACK

3. Select the sensor whose priority you want to adjust, then press the **ENT/ACK** key. The [SENSOR PORT] pop up window is displayed.
4. Select the appropriate port, then press the **ENT/ACK** key.
5. Repeat step 3 to step 4 for other port priorities.
6. Press the **MENU/ESC** key to return to the [INITIAL SET] menu.

SENSOR PORT
SENSOR1
SENSOR2
SENSOR3
COM4
COM5
COM6
LAN

## 3.6 Network Set Up

1. Access the [INITIAL SET] menu, following the procedure outlined in "How to access the [INITIAL SET] menu" on page 3-1.
2. Select [NETWORK], then press the **ENT/ACK** key.

NETWORK	
IP ADDRESS	: 172 . 031 . 024 . 004
SUBNET MASK	: 255 . 255 . 000 . 000
GATEWAY	: 000 . 000 . 000 . 000
OWN SFI	: AI0001
[RX SFI]	
LL/SOG/COG	: GP0001
HDG	: GP0002
ROT	: GP0002
<SAVE>	
[CURSOR] : CURSOR    [ENT] : SELECT    [MENU] : BACK	

Standard network settings screen.

NETWORK (NAVNET)	
IP ADDRESS	: 172 . 031 . 024 . 004
SUBNET MASK	: 255 . 255 . 000 . 000
GATEWAY	: 000 . 000 . 000 . 000
NAVNET PORT	: 10000
HOST NAME	: AIS0
[OUTPUT AT STARTUP]	
AIS INFO	: ON
ZDA INFO	: OFF
GPS INFO	: OFF
<SAVE>	
[CURSOR] : CURSOR    [ENT] : SELECT    [MENU] : BACK	

NAVNET network settings screen.

3. [IP ADDRESS] is selected. Press the **ENT/ACK** key to show the IP address settings pop up window.
4. Set the IP address, then press the **ENT/ACK** key.
5. Select and set [SUBNET MASK] and [GATEWAY] in a similar fashion. For NavNet networks, go to step 6, for other network types, go to step 13.
6. Select [NAVNET PORT], then press the **ENT/ACK** key.
7. Input the NavNet port which this unit is connected to, then press the **ENT/ACK** key.
8. Select [HOST NAME], then press the **ENT/ACK** key.
9. Input the name for this unit within the NavNet network, then press the **ENT/ACK** key.
10. Select [AIS INFO], then press the **ENT/ACK** key.
11. Select [ON] to enable AIS data output to the NavNet network when this unit is turned on. Select [OFF] to disable AIS data output when this unit is turned on.
12. Set [ZDA INFO] and [GPS INFO] in the same manner as [AIS INFO], then go to step 18.
13. Select [OWN SFI] (System Function ID), then press the **ENT/ACK** key.
14. Set the [OWN SFI], then press the **ENT/ACK** key.
15. Select an option from the [RX SFI] options.  
When part of a LAN network, the FA-170 may receive data for the same item from several sources, resulting in unstable calculations. For stable calculations, set the SFI for the sensor to be used as the fixed data source.  
For example, if [LL/SOG/COG] is set as "AA111", the FA-170 only uses data from the sensor with the ID "AA111" to calculate [LL/SOG/COG].
16. Input the network ID for the sensor.
17. Repeat step 15 to 16 as required.
18. Confirm the settings are correct, then select [<SAVE>] and press the **ENT/ACK** key. A confirmation pop up is displayed.  
**Note:** If no changes are made to the settings, [<SAVE>] is not selectable.
19. Select [NO] to change the settings further. Select [YES] to accept the new settings, the unit now shuts down automatically to apply the new settings. After the unit shuts down, press the power key to restart the unit.

### 3.7 SERVICE Menu Operations

The [SERVICE] menu is password protected. Contact FURUNO for password details.

[SERVICE] menu access is required to setup the following items:

- [ALERT MODE] settings
- Network protocol settings
- Restore Factory settings

SERVICE	
1	CH SET ▶
2	AIS SET ▶
3	<b>ALERT SET ▶</b>
4	FACTORY SET ▶
5	OTHER SET ▶
6	INITIALIZE ▶
7	TEST ▶
8	MAINTENANCE ▶
9	DEVELOPER ▶

#### 3.7.1 How to access the SERVICE menu

1. From the [MAIN] menu, select [SERVICE], then press the **ENT/ACK** key. The password input pop up window appears.
2. Input the password then press the **ENT/ACK** key.

#### 3.7.2 How to hide CPA/TCPA

Factory default settings show CPA/TCPA. You can hide (or re-show) the CPA/TCPA indications, by doing the following:

1. Access the [SERVICE] menu referring to the procedure outlined at the start of this section.
2. Select [AIS SET], then press the **ENT/ACK** key.
3. Select [CPA/TCPA], then press the **ENT/ACK** key. The options pop up window appears.
4. Select [SHOW] or [HIDE] as appropriate, then press the **ENT** key.
5. Press the **MENU/ESC** key to return to the [INITIAL SET] menu, or press the **DISP** key to close all open menus.

AIS SET	
1	REGULATION : INT'L
2	OUTPUT VDM : NORMAL
3	<b>CPA/TCPA : SHOW</b>

SHOW
HIDE

#### 3.7.3 How to set the alert mode

The alert mode can be set according to the vessel's configuration. The available alert modes are: [LEGACY ED.1], [LEGACY ED.2], [ALERT IF1] and [ALERT IF2].

1. Access the [SERVICE] menu referring to the procedure outlined at the start of this section.
2. Select [ALERT SET], then press the **ENT/ACK** key.
3. Select [ALERT MODE], then press the **ENT/ACK** key.

**Note:** The [OPERATIONAL] setting is for technical personnel only. Do not change this setting.

ALERT SET	
1	<b>ALERT MODE : LEGACY ED.2</b>
2	OPERATIONAL

LEGACY ED.1
LEGACY ED.2
ALERT IF1
ALERT IF2

4. Select the appropriate [ALERT MODE] setting, then press the **ENT/ACK** key. Select [ALERT IF1] for vessels configured with AMS, [ALERT IF2] for vessels configured with BAM.
5. Press the **MENU/ESC** key to return to the [INITIAL SET] menu, or press the **DISP** key to close all open menus.

### 3.7.4 How to set the network protocol

Set the LAN network protocol according to the vessel’s on-board network. [NAVNET] protocol should be used where a NavNet series unit is the LAN network hub. Select [450] for all other LAN networks.

1. Access the [SERVICE] menu referring to the procedure outlined at the start of this section.
2. Select [OTHER SET], then press the **ENT/ACK** key.
3. Select [NW PROTOCOL], then press the **ENT/ACK** key.

**Note:** The rest of the [OTHER SET] menu items are for technical personnel only. Do not change these setting.

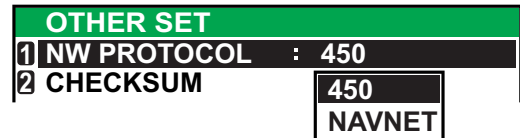

4. Select the appropriate protocol, then press the **ENT/ACK** key. A confirmation pop up is displayed.
5. Select [YES] to accept the new setting or [NO] to cancel and return to the options. Selecting [YES] will restart the unit.

### 3.7.5 How to restore factory settings

This procedure resets the units to factory settings.

Be sure to set all appropriate settings from the [INITIAL SET] menu after completing this procedure.

1. Access the [SERVICE] menu referring to the procedure outlined at the start of this section.
2. Select [INITIALIZE], then press the **ENT/ACK** key.
3. Select [RESTORE FACTORY SET], then press the **ENT/ACK** key. The confirmation pop up window shown below-right is displayed.

**Note:** The rest of the [INITIALIZE] menu items are for technical personnel only. Do not change these settings.

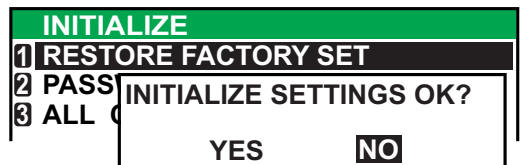

4. Select the [YES] or [NO] as appropriate, then press the **ENT/ACK** key.  
 [YES]: Accept the new settings and restart the unit.  
 [NO]: Cancel and return to the options.

### 3. SETTINGS AND ADJUSTMENTS

This page is intentionally left blank.

# APPENDIX 1 JIS CABLE GUIDE

Cables listed in the manual are usually shown as Japanese Industrial Standard (JIS). Use the following guide to locate an equivalent cable locally.

JIS cable names may have up to 6 alphabetical characters, followed by a dash and a numerical value (example: DPYC-2.5).

For core types D and T, the numerical designation indicates the *cross-sectional Area (mm<sup>2</sup>)* of the core wire(s) in the cable.

For core types M and TT, the numerical designation indicates the *number of core wires* in the cable.

## 1. Core Type

D: Double core power line

T: Triple core power line

M: Multi core

TT: Twisted pair communications  
(1Q=quad cable)

## 2. Insulation Type

P: Ethylene Propylene

Rubber

## 3. Sheath Type

Y: PVC (Vinyl)

## 4. Armor Type

C: Steel

## 5. Sheath Type

Y: Anticorrosive vinyl sheath

## 6. Shielding Type

S: All cores in one sheath

-S: Individually sheathed cores

SLA: All cores in one shield, plastic tape w/aluminum tape

-SLA: Individually shielded cores, plastic tape w/aluminum tape



DPYCY



TPYCY

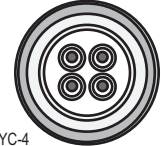

MPYC-4

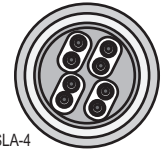

TTYCSLA-4

EX: <sup>1 2 3 4 5 6</sup> TTYC YSLA - 4  
Designation type | # of twisted pairs

EX: <sup>1 2 3 4</sup> M P Y C - 4  
Designation type | # of cores

The following reference table lists gives the measurements of JIS cables commonly used with Furuno products:

Type	Core		Cable Diameter	Type	Core		Cable Diameter
	Area	Diameter			Area	Diameter	
DPYC-1.5	1.5mm <sup>2</sup>	1.56mm	11.7mm	TTYCS-1	0.75mm <sup>2</sup>	1.11mm	10.1mm
DPYC-2.5	2.5mm <sup>2</sup>	2.01mm	12.8mm	TTYCS-1T	0.75mm <sup>2</sup>	1.11mm	10.6mm
DPYC-4	4.0mm <sup>2</sup>	2.55mm	13.9mm	TTYCS-1Q	0.75mm <sup>2</sup>	1.11mm	11.3mm
DPYC-6	6.0mm <sup>2</sup>	3.12mm	15.2mm	TTYCS-4	0.75mm <sup>2</sup>	1.11mm	16.3mm
DPYC-10	10.0mm <sup>2</sup>	4.05mm	17.1mm	TTYCSLA-1	0.75mm <sup>2</sup>	1.11mm	9.4mm
DPYCY-1.5	1.5mm <sup>2</sup>	1.56mm	13.7mm	TTYCSLA-1T	0.75mm <sup>2</sup>	1.11mm	10.1mm
DPYCY-2.5	2.5mm <sup>2</sup>	2.01mm	14.8mm	TTYCSLA-1Q	0.75mm <sup>2</sup>	1.11mm	10.8mm
DPYCY-4	4.0mm <sup>2</sup>	2.55mm	15.9mm	TTYCSLA-4	0.75mm <sup>2</sup>	1.11mm	15.7mm
MPYC-2	1.0mm <sup>2</sup>	1.29mm	10.0mm	TTYCY-1	0.75mm <sup>2</sup>	1.11mm	11.0mm
MPYC-4	1.0mm <sup>2</sup>	1.29mm	11.2mm	TTYCY-1T	0.75mm <sup>2</sup>	1.11mm	11.7mm
MPYC-7	1.0mm <sup>2</sup>	1.29mm	13.2mm	TTYCY-1Q	0.75mm <sup>2</sup>	1.11mm	12.6mm
MPYC-12	1.0mm <sup>2</sup>	1.29mm	16.8mm	TTYCY-4	0.75mm <sup>2</sup>	1.11mm	17.7mm
TPYC-1.5	1.5mm <sup>2</sup>	1.56mm	12.5mm	TTYCY-4S	0.75mm <sup>2</sup>	1.11mm	21.1mm
TPYC-2.5	2.5mm <sup>2</sup>	2.01mm	13.5mm	TTYCY-4SLA	0.75mm <sup>2</sup>	1.11mm	19.5mm
TPYC-4	4.0mm <sup>2</sup>	2.55mm	14.7mm	TTYCYS-1	0.75mm <sup>2</sup>	1.11mm	12.1mm
TPYCY-1.5	1.5mm <sup>2</sup>	1.56mm	14.5mm	TTYCYS-4	0.75mm <sup>2</sup>	1.11mm	18.5mm
TPYCY-2.5	2.5mm <sup>2</sup>	2.01mm	15.5mm	TTYCYSLA-1	0.75mm <sup>2</sup>	1.11mm	11.2mm
TPYCY-4	4.0mm <sup>2</sup>	2.55mm	16.9mm	TTYCYSLA-4	0.75mm <sup>2</sup>	1.11mm	17.9mm
				TTYCSLA-7	0.75mm <sup>2</sup>	1.11mm	20.8mm

# APPENDIX 2 DIGITAL INTERFACE

## IEC61162-1/2 data sentences

IEC61162-1/2 format data is input or output from the data port COM1-COM6.

The table below shows the input/output data specifications for the transponder unit (FA-1701).

Port	Menu setting	Input/Output	Data format	Speed
COM1 to COM3	EXT DISPLAY	Input/output	IEC61162-1/2	4800 or 38400 bps
	LONG RANGE	Input/output	IEC61162-1/2	4800 or 38400 bps
	BEACON	Input	RTCM SC104	4800bps
COM4 to COM6	EXT DISPLAY	Input/output	IEC61162-1/2	4800 or 38400 bps
	LONG RANGE	Input/output	IEC61162-1/2	4800 or 38400 bps
	SENSOR	Input	IEC61162-1/2	4800 or 38400 bps
	BEACON	Input	RTCM SC104	4800bps
SENSOR1 to SENSOR3	SENSOR	Input	IEC61162-1	4800bps

## Priority for input data/sentences

Sentence (Priority)	Contents
GNS>GLL>GGA>RMC	Position
VBW>RMC>VTG>OSD	Speed over ground
RMC>VTG>OSD	Course over ground
THS>HDT>OSD	Heading
ROT> Calculated value	Rate of turn

## Digital Interface (IEC 61162-1 Edition 5, IEC 61162-2)

### **Sentence data**

#### Input sentences

ABM, ACA, ACK, ACM, ACN, AIQ, AIR, BBM, DTM, EPV, GBS, GGA, GLL, GNS, HBT, HDT, LRF, LRI, OSD, PIWWIVD, PIWWSPW, PIWWSSD, PIWWVSD, RMC, ROT, SPW, SSD, THS, VBW, VSD, VTG

#### Output sentences

ABK, ACA, ACS, ALC, ALF, ALR, ARC, EPV, HBT, LRI, LRF, LR1, LR2, LR3, NAK, SSD, TRL, TXT, PIWWIVD, PIWWSPR, PIWWSSD, PIWWVSD, VDM, VDO, VER, VSD



Transmission intervals

Sentence	Interval	Sentence	Interval
ABK	With each event	ACA	When requested, or with each event
ACS	Transmitted after ACA	ALC	30 seconds
ALF	When requested, or with each event	ALR	30 seconds
ARC	With each event	EPV	When requested, or with each event
HBT	50 seconds	LR1	With each event
LR2	With each event	LR3	With each event
LRF	With each event	LRI	With each event
NAK	With each event	PIWWIVD	When requested, or with each event
PIWWSPR	When requested, or with each event	PIWWSSD	When requested, or with each event
PIWWVSD	When requested, or with each event	SSD	When requested, or with each event
TRL	When requested, or with each event	TXT	When requested, or with each event
VDM	With each event	VDO	1 second or with each event
VER	When requested, or with each event, or powered on	VSD	When requested, or with each event

**Load requirements as listener**

Isolation: Provided

Input Impedance: Input Impedance: 110 ohms (130K ohms without jumper plug)

Max. Voltage: ±14 V to GNDiso

Threshold: ±0.2 V (A-B)

Output drive capability

*Differential driver output*

R=50 ohm 2 v min.

R=27 ohm 1.5 V min.

*Driver short-circuit current*

60 mA min. 150 mA max.

**Data transmission**

Data is transmitted in serial asynchronous form in accordance with the standard referenced in 2.1 of IEC 61162-1/2. The first bit is a start bit and is followed by data bits, least-significant-bit as illustrated below.

The following parameters are used:

Baud rate: 38.4 Kbps /4800 bps

Data bits: 8 (D7 = 0), parity none

Stop bits: 1

IEC61162-1:Edition 4.0 2010-11  
 IEC61162-2:First Edition 1998-09  
 IEC61162-450:Edition 1.0 2011-06

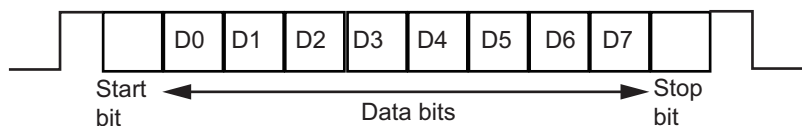

**Serial & contact interface I/O circuit**

COM1 to 6

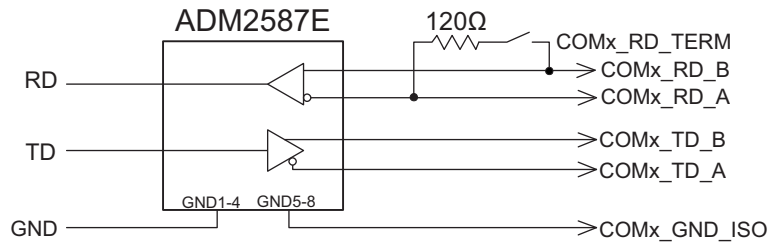

External Alarm

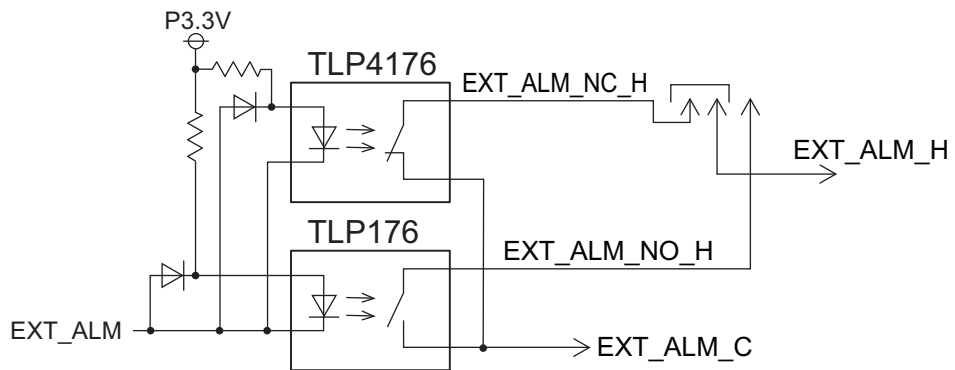

Alarm Acknowledge

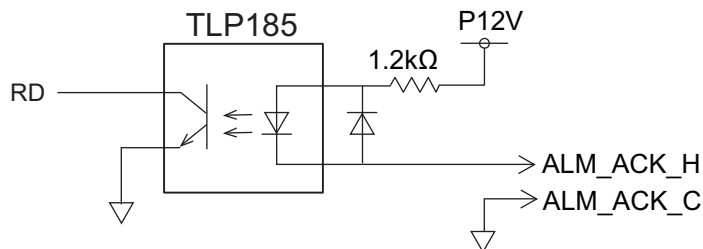

Sensor Input

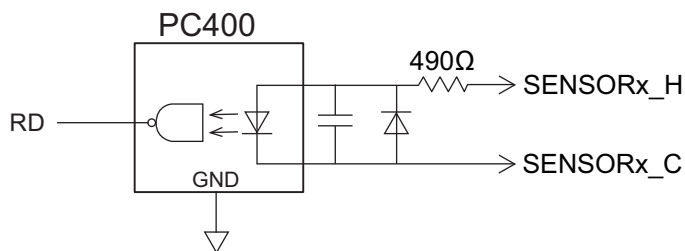

Blue Sign

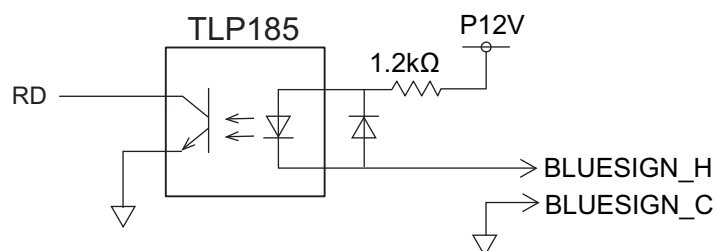

**Sentence description****Input sentences****ABM - Addressed binary and safety related message**

!\*\*ABM, x, x, x, xxxxxxxx, x, x.x, s--s, x, \*hh<CR><LF>  
 1 2 3 4 5 6 7 8

1. Total number of sentences needed to transfer the message (1 to 9)
2. Message sentence number (1 to 9)
3. Message sequence identifier (0 to 3)
4. The MMSI of destination AIS unit for the ITU-R M.1371 message (9 digits, NULL)
5. AIS channel for broadcast of the radio message (0 to 3, NULL)
6. VDL message number (6, 12, 25, 26, 70, 71, NULL), see ITU-R M.1371
7. Encapsulated data (1 to 63 bytes)
8. Number of fill-bits (0 to 5)

**ACA - AIS regional channel assignment message**

\$\*\*ACA,x,IIII.II, a,yyyyy.yy,a,IIII.II,a,yyyyy.yy,a,x,xxxx,x,xxxx,x,x,x,a,x,hmmss.ss,\*hh<CR><LF>  
 1 2 3 4 5 6 7 8 9 1011121314 15

- |   |                             |
|---|-----------------------------|
| 1. Sequence number (0 to 9, NULL)                 | 9. Channel B                |
| 2. Region Northeast corner latitude (N, S, NULL)  | 10. Channel B bandwidth     |
| 3. Region Northeast corner longitude (E, W, NULL) | 11. Tx/Rx mode control      |
| 4. Region Southwest corner latitude (N, S, NULL)  | 12. Power level control     |
| 5. Region Southwest corner longitude (E, W, NULL) | 13. Information source      |
| 6. Transition Zone Size                           | 14. In-use flag             |
| 7. Channel A                                      | 15. Time of "in-use" change |
| 8. Channel A bandwidth                            |                             |

**ACK - Acknowledge**

\$\*\*ACK,xxx,\*hh<CR><LF>  
 1

1. Local alarm number (identifier) (000 to 999)

**ACN(ACM) - Alert command**

\$\*\*ACN(ACM),hmmss.ss,aaa,x.x,x.x,c,a\*hh<CR><LF>  
 1 2 3 4 5 6

1. Time
2. Manufacturer mnemonic code
3. Alert Identifier
4. Alert Instance (1 to 999999)
5. Alert command  
(A=acknowledge, Q=request/repeat information, O=responsibility transfer S=silence)
6. Sentence status flag

**AIQ - Query sentence**

\$\*\*AIQ,ccc,\*hh<CR><LF>  
 1

1. Information requested (ACA\*<sup>3</sup>, IWWIVD\*<sup>1\*2</sup>, IWWVSD\*<sup>1\*2</sup>, IWWSSD\*<sup>1\*2</sup>, PIWWIVD\*<sup>2</sup>, PIWWVSD\*<sup>2</sup>, PIWWSSD\*<sup>2</sup>, SSD, TRL, TXT, VER, VSD)
- \*1: Compatible with Tresco Inland ECDIS viewer.
- \*2: Valid only when AIS is in INLAND mode.
- \*3: When ACA is requested, ACS is also sent immediately after ACA.

## APPENDIX 2 DIGITAL INTERFACE

### AIR - AIS interrogation request

\$\*\*AIR,xxxxxxx,x.x,x,x,x,xxxxxxx,x.x,x, a, x.x, x.x, x.x \*hh<CR><LF>  
1 2 3 4 5 6 7 8 9 10 11 12

1. MMSI of interrogated station 1
2. ITU-R M.1371 message requested from station 1
3. Message sub-section
4. ITU-R M.1371 second message requested from station 1
5. Message sub-section
6. MMSI of interrogated station 2
7. ITU-R M.1371 message requested from station 2
8. Message sub-section
9. Channel used on request
10. No use. Response slot for Message ID 1.1 of Message 15
11. No use. Response slot for Message ID 1.2 of Message 15
12. No use. Response slot for Message ID 2.1 of Message 15

### BBM - AIS broadcast binary message.

\$\*\*BBM,x,x,x,x,xx,s--s,x,\*hh<CR><LF>  
12 3 4 5 6 7

1. Total number of sentences needed to transfer the message (1 to 9)
2. Sentence number (1 to 9)
3. Sequential Message identifier (0 to 9)
4. AIS channel for broadcast of the radio message
5. VDL message no. (8, 14, 25, 26, 70 or 71, NULL)
6. Encapsulated data
7. Number of fill-bits, 0 to 5

### DTM - Datum reference

\$\*\*DTM,ccc,a,x.x,a,x.x,a,x.x,ccc,\*hh<CR><LF>  
1 2 3 4 5 6 7 8

1. Local datum (W84=WGS84, W72=WGS72, S85=SGS85, P90=PE90, User defined=999, IHO datum code, NULL)
2. Local datum subdivision code (NULL or one character)
3. Lat offset, min (-59.99999 to 59.99999)
4. N/S
5. Lon offset, min (-59.99999 to 59.99999)
6. E/W
7. Altitude offset, meters (no use)
8. Reference datum (W84=WGS84, W72=WGS72, S85=SGS85, P90=PE90)

### EPV - Command or report equipment property value

\$ \*\*EPV,s,cc,c--c,x.x,c--c\*hh<CR><LF>  
1 2 3 4 5

1. Sentence status flag (C=Configuration command)
2. Equipment type
3. Unique identifier (MMSI)
4. Property identifier for property to be set
5. Value of property to be set

GBS - GNSS satellite fault detection

\$\*\*GBS, hhmss.ss, x.x, x.x, x.x, xx, x.x, x.x, x.x h, h, \*hh<CR><LF>  
 1 2 3 4 5 6 7 8 9 10

1. UTC time of GGA or GNS fix associated with this sentence
2. Expected error in latitude (0.0 to 999.9)
3. Expected error in longitude (0.0 to 999.9)
4. Expected error in altitude (no use)
5. ID number of most likely failed satellite (no use)
6. Probability of missed detection for most likely failed satellite (no use)
7. Estimate of bias in meters on most likely failed satellite (no use)
8. Standard deviation of bias estimate (no use)
9. GNSS system ID
- 10 GNSS signal ID

GGA - Global positioning system (GPS) fix data

\$\*\*GGA, hhmss.ss, llll.ll, a, yyyy.yy, a, x, xx, x.x, x.x, M, x.x, M, x.x, xxxx,\*hh<CR><LF>  
 1 2 3 4 5 6 7 8 9 10 11 12 13 14

1. UTC of position (0.00 to 235959.99)
2. Latitude (0.00000 to 9000.00000)
3. N/S
4. Longitude (0.00000 to 18000.00000)
5. E/W
6. GPS quality indicator
7. Number of satellites in use, 00 to 12, may be different from the number in view (no use)
8. Horizontal dilution of precision (no use)
9. Antenna altitude above/below mean sea level (geoid) (no use)
10. Units of antenna altitude, m (no use)
11. Geoidal separation (no use)
12. Units of geoidal separation, m (no use)
13. Age of differential GPS data (no use)
14. Differential reference station ID, 0000 to 1023 (no use)

GLL - Geographic position - latitude/longitude

\$\*\*GLL, llll.lll, a, yyyy.yy, a, hhmss.ss, a, x, \*hh<CR><LF>  
 1 2 3 4 5 6 7

1. Latitude (0.00000 to 9000.00000)
2. N/S
3. Longitude (0.00000 to 18000.00000)
4. E/W
5. UTC of position (0.00 to 235959.99)
6. Status (A=data valid)
7. Mode indicator (A=Autonomous, D=Differential, R=Real time kinematic, F=Float RTK, P=Precise)

GNS - GNSS fix data

\$\*\*GNS,hhmmss.ss,llll.ll,a,llll.ll,a,c--c,xx,x.x,x.x,x.x,x.x,x.x,x.x,a\*hh<CR><LF>  
 1 2 3 4 5 6 7 8 9 10 11 12 13

1. UTC of position (0.00 to 235959.99)
2. Latitude (0.00000 to 9000.00000)
3. N/S
4. Longitude (0.00000 to 18000.00000)
5. E/W
6. Mode indicator (A=Autonomous, D=Differential, E=Estimated Mode, F=Float RTK, M=Manual Input Mode, N=No fix, P=Precise, R=Real Time Kinematic, S=Simulator Mode)
7. Total number of satellites in use (Not used)
8. HDOP (Not used)
9. Antenna altitude, meters (Not used)
10. Geoidal separation (Not used)
11. Age of differential data (Not used)
12. Differential reference station ID (Not used)
13. Navigational status indicator (S=Safe; C=Caution; U=Unsafe; V=Not valid)

HBT - Heart beat supervision

\$--HBT, x. x, A, x\*hh<CR><LF>  
 1 2 3

1. Configured repeat interval (1 to 999, NULL)
2. Equipment status (A/V)
3. Sequential sentence identifier (0 to 9, NULL)

HDT - Heading - true

\$\*\*HDT,xxx.x,T\*hh<CR><LF>  
 1 2

1. Heading, degrees (0.000 to 359.999)
2. True (T, NULL)

LRF - Long-range function

\$\*\*LRF,x,xxxxxxxx,c--c,c--c,c--c\*hh<CR><LF>  
 1 2 3 4 5

1. Sequence number (0 to 9)
2. MMSI of requester
3. Name of requester (1 to 20 characters, NULL)
4. Function request  
 (1 to 26 characters (Preceded by A, B, C, E, F, I, O, P, U, W), NULL)  
 A : Ship's name, call sign and IMO No.  
 B : Date and time of message composition  
 C : Position  
 E : Course Over Ground  
 F : Speed Over Ground  
 I : Destination and Estimated Time of Arrival (ETA)  
 O : Draught  
 P : Ship/Cargo  
 U : Ship's length, breadth and type  
 W : Persons on board
5. Function reply status  
 (1 to 26 characters (Preceded by 2, 3, 4), NULL)  
 2: Information available and provided in the following LR1, LR2, LR3 sentence;  
 3: Information not available from AIS unit;  
 4: Information is available but not provided (i.e. restricted access determined by the ship's master)

LRI - Long-range interrogation

```
$**LRI,x,a,xxxxxxxx,xxxxxxxx,lll.ll,a,yyyy.yy,a,lll.ll,a,yyyy.yy,a*hh<CR><LF>
```

1 2 3 4 5 6 7 8

1. Sequence number (0 to 9)
2. Control flag
3. MMSI of requestor
4. MMSI of destination
5. Latitude - N/S for north-east corner (0000.0000 to 9000.0000, NULL)
6. Longitude - E/W for north-east corner (0000.0000 to 18000.0000, NULL)
7. Latitude - N/S for south-west corner (0000.0000 to 9000.0000, NULL)
8. Longitude - E/W for south-west corner (0000.0000 to 18000.0000, NULL)

OSD - Own ship data

```
$**OSD, x.x, A, x.x, a, x.x, x.x, a *hh<CR><LF>
```

1 2 3 4 5 6 7 8 9

1. Heading, degrees true (0.00 to 359.99)
2. Heading status (A=data valid)
3. Vessel course, degrees true (0.00 to 359.99)
4. Course reference (B=Bottom tracking log, R=Radar tracking (of fixed target), P=Positioning system ground reference)
5. Vessel speed (0.00 to 999.999)
6. Speed reference, (B/R/P) (See 4.)
7. Vessel set, degrees true, manually entered (Not used)
8. Vessel drift (speed), manually entered (Not used)
9. Speed units (K=km/h N=Knots S=statute miles/h)

RMC - Recommended minimum specific GPS/TRANSIT data

```
$**RMC, hhmmss.ss, A, lll.ll, a, yyyy.yy, a, x.x, x.x, ddmmyy, x.x, a, a, a *hh<CR><LF>
```

1 2 3 4 5 6 7 8 9 10 11 12 13

1. UTC of position fix (0.00 to 235959.99)
2. Status (A=data valid)
3. Latitude (0000.0000 to 9000.0000)
4. N/S
5. Longitude (0000.0000 to 18000.0000)
6. E/W
7. Speed over ground, knots (0.00 to 999.99)
8. Course over ground, degrees true (0.00 to 359.99)
9. Date (010100 to 311299)
10. Magnetic variation, degrees E/W (Not used)
11. E/W (Not used)
12. Mode indicator (A=Autonomous, D=Differential, F=Float RTK, P=Precise, R=Real time kinematic)
13. Navigational status indication (S=Safe; C=Caution; U=Unsafe; V=Navigational status not valid, equipment is not providing navigational status indication, NULL)

ROT - Rate of turn

```
$--ROT,x.x,A*hh<CR><LF>
```

1 2

1. Rate of turn, deg/min, "-"=bow turns to port (-9999.99 to 9999.99)
2. Status (A=data valid)

SPW - Security password sentence

```
$**SPW,ccc,c--c,x,c--c*hh<CR><LF>
```

1 2 3 4

1. Password protected sentence
2. Unique identifier (MMSI=000000000 to 999999999, NULL)
3. Password level (1=User defined,2=Administrator)
4. Password (Maximum 32 characters, text only)

## APPENDIX 2 DIGITAL INTERFACE

### SSD - AIS ship static data

\$\*\*SSD,c--c,c--c,xxx,xxx,xx,xx,c, aa\*hh<CR><LF>  
1 2 3 4 5 6 7 8

1. Ship's call sign (1 to 7 characters, NULL)
2. Ship's name (1 to 20 characters, NULL)
3. Pos. ref. point distance, "A," from bow (0 to 511 Meters, NULL)
4. Pos. ref. point distance, "B," from stern (0 to 511 Meters, NULL)
5. Pos. ref. point distance, "C," from port beam (0 to 63 Meters, NULL)
6. Pos. ref. point distance, "D," from starboard beam (0 to 63 Meters, NULL)
7. DTE indicator flag
8. Source identifier (2 characters, NULL)

### THS - True heading and status

\$--THS, x.x, a \*hh<CR><LF>  
1 2

1. Heading, degrees true (0.00 to 359.99)
2. Mode indicator (A=Autonomous)

### VBW - Dual ground/water speed

\*\*VBW,x.x,x.x,x.x,x.x,x.x,x.x,x.x,x.x,x.x,x.x\*hh<CR><LF>  
1 2 3 4 5 6 7 8 9 10

1. (No use) Longitudinal water speed, knots (-9999.99 to 9999.99)
2. (No use) Transverse water speed, knots (-9999.99 to 9999.99)
3. (No use) Status: water speed, A=data valid V=data invalid
4. Longitudinal ground speed, knots (-999.999 to 999.999)
5. Transverse ground speed, knots (-999.999 to 999.999)
6. Status: ground speed (A=data valid, NULL)
7. (No use) Stern transverse water speed, knots (-9999.99 - 9999.99)
8. (No use) Status: stern water speed, A=data valid V=data invalid
9. (No use) Stern transverse ground speed, knots (-9999.99 - 9999.99)
10. (No use) Status: stern ground speed, A=data valid V=data invalid

### VSD - AIS voyage static data

\$--VSD,x.x,x.x,x.x,c--c,hmmss.ss,xx,xx,x.x,x.x\*hh<CR><LF>  
1 2 3 4 5 6 7 8 9

1. Type of ship and cargo category (0 to 255, NULL)
2. Maximum present static draught (0 to 25.5m, NULL)
3. Persons on-board (0 to 8191, NULL)
4. Destination (1 to 20 characters, NULL)
5. Estimated UTC of arrival at destination (0 to 235959.99, NULL)
6. Estimated day of arrival at destination (00 to 31(UTC), NULL)
7. Estimated month of arrival at destination (00 to 12(UTC), NULL)
8. Navigational status (0 to 15, NULL)
9. Regional application flags (0 to 15, NULL)

### VTG - Course over ground and ground speed

\$--VTG, x.x, T, x.x, M, x.x, N, x.x, K, a,\*hh <CR><LF>  
1 2 3 4 5 6 7 8 9

1. Course over ground, degrees (0.00 to 359.99)
2. T=True (fixed)
3. (No use) Course over ground, degrees (0.0 to 359.99)
4. (No use) M=Magnetic (fixed)
5. Speed over ground, knots (0.00 to 999.99)
6. N=Knots (fixed)
7. Speed over ground (0.00 to 999.99)
8. K=km/h (fixed)
9. Mode indicator (A=Autonomous mode, D=Differential mode, P=Precise)



**Output sentences**

**ABK - AIS addressed and binary broadcast acknowledgment**

\$\*\*ABK,xxxxxxxx,x,x.x,x,x,\*hh<CR><LF>  
                   1   2  3 4 5

1. MMSI of the addressed AIS unit
2. AIS channel of reception
3. Message ID
4. Message sequence number
5. Type of acknowledgement

**ACA** - See “ACA - AIS regional channel assignment message” on page AP-5.

**ACS - Channel management information source**

\$\*\*ACS,x,xxxxxxxx,hmms.ss,xx,xx,xxx,\*hh<CR><LF>  
                   1   2          3   4  5  6

1. Sequence number (0 to 9)
2. MMSI of originator (000000000 to 999999999, NULL)
3. UTC at receipt of channel management information (000000 to 235959, NULL)
4. UTC day (01 to 31, NULL)
5. UTC month (01 to 12, NULL)
6. UTC year (2010 to 2060, NULL)

**ALC - Cyclic alert list**

\$\*\*ALC,xx,xx,xx,x,x,aaa,x,x,x,x,x,.....,\*hh<CR><LF>  
                   1  2  3  4  5  6  7  8  9

1. Total number of sentences for this message (01 to 99)
2. Sentence number (01 to 99)
3. Sequential message identifier (00 to 99)
4. Number of alert entries
5. Manufacturer mnemonic code
6. Alert identifier
7. Alert instance
8. Revision counter
9. Additional Alert entries (see Note)

**Note:** Alert entry 0 - n: Each alert entry consists of

- Manufacturer Identifier (see ALF Manufacturer Identifier)
- Alert Identifier (see ALF Alert identifier)
- Alert instance (see ALF instance)
- Revision counter (see ALF revision counter)

Alert entry 1  
See Note

ALF - Alert sentence

\$\*\*ALF,x,x,x,hhmmss.ss,a,a,a,aaa,x.x,x.x,x.x,x,c--c,\*hh<CR><LF>  
 1 2 3 4 5 6 7 8 9 10 11 12 13

1. Total number of ALF sentences for this message (1, 2)
2. Sentence number (1, 2)
3. Sequential message identifier (0 to 9)
4. Time of last change (hhmmss.ss, NULL)
5. Alert category (B=Category B, C=Category C, NULL)
6. Alert priority (W=Warning, C=Caution, NULL)
7. Alert state  
 V=active - unacknowledged, S=active - silenced,  
 A=active - acknowledged or active, O=active - responsibility transferred,  
 U=rectified - unacknowledged, N=normal, NULL
8. Manufacturer mnemonic code (FEC, NULL)
9. Alert identifier (001 to 999999)
10. Alert instance (NULL)
11. Revision counter (1 to 99)
12. Escalation counter (0 to 9)
13. Alert text

ALR - Set state

\$\*\*ALR,hhmmss.ss,xxx,A,A,c--c,\*hh<CR><LF>  
 1 2 3 4 5

1. Time of alarm condition change, UTC
2. Unique alarm number (identifier) at alarm source (000 to 999, NULL)
3. Alarm condition (A=threshold exceeded, V=not exceeded)
4. Alarm acknowledge state (A=acknowledged, V=not acknowledged)
5. Alarm description text (alphanumeric)

ARC - Alert command refused

\$\*\*ARC,hhmmss.ss,aaa,x.x,x.x,c\*hh<CR><LF>  
 1 2 3 4 5

1. Time
2. Manufacturer mnemonic code
3. Alert identifier (001 to 999999)
4. Alert instance (NULL)
5. Refused alert command  
 A=acknowledge  
 Q=request/repeat information  
 O=responsibility transfer  
 S=silence

EPV - Command or report equipment property value"

\$\*\*EPV,s,cc,c--c,x.x,c--c\*hh<CR><LF>  
 1 2 3 4 5

1. Sentence status flag (Fixed: R=Response)
2. Equipment type (Fixed: AI)
3. Unique identifier (MMSI: 00000000 to 999999999)
4. Property identifier for property to be set (106 to 113)
5. Value of property to be set

HBT - Heart beat supervision

\$--HBT, x. x, A, x\*hh<CR><LF>  
 1 2 3

1. Configured repeat interval (50)
2. Equipment status (A)
3. Sequential sentence identifier (0 to 9)

LRF - See "LRF - Long-range function" on page AP-8.

LR1 - Long-range reply with destination for function request "A"

\$\*\*LR1,x,xxxxxxxx,xxxxxxxx,c--c,c--c,xxxxxxxx\*hh<CR><LF>  
 1 2 3 4 5 6

1. Sequence number
2. MMSI of responder
3. MMSI of requester (reply destination)
4. Ship's name (1 to 20 characters)
5. Call sign (1 to 7 characters)
6. IMO number, (9-digit number)

LR2 - Long-range reply for function requests "B, C, E, and F"

\$\*\*LR2,x,xxxxxxxx,xxxxxx,hhmmss.ss,lll.ll,a,yyyy.yy,a,x.x,T,x.x,N\*hh<CR><LF>  
 1 2 3 4 5 6 7 8

1. Sequence number
2. MMSI of responder
3. Date (ddmmyy)
4. UTC of Position
5. Latitude - N/S
6. Longitude - E/W
7. Course over ground, degrees True
8. Speed over ground, Knots

LR3 - Long-range reply for function requests "I, O, P, U and W"

\$\*\*LR3,x,xxxxxxxx,c--c,xxxxx,hhmmss.ss,x.x,cc,x.x,x.x,cc,x.x\*hh<CR><LF>  
 1 2 3 4 5 6 7 8 9 10 11

1. Sequence number
2. MMSI of responder
3. Voyage destination (1 to 20 characters)
4. ETA date (ddmmyy)
5. ETA time
6. Draught
7. Ship/cargo
8. Ship length
9. Ship breadth
10. Ship type
11. Persons (0 to 8191)

LRI - See "LRI - Long-range interrogation" on page AP-9.

NAK - Negative acknowledgment

\$\*\*NAK,cc,ccc,c--c,x.x,c--c \*hh<CR><LF>  
 1 2 3 4 5

1. Talker identifier
2. Affected sentence formatter
3. Unique identifier
4. Reason code for negative acknowledgment (0=Query functionality not supported, 1=Sentence formatter not supported, 2=Sentence formatter supported, but not enabled; 3=Senetence formatter supported and enabled, but temporarily unavailable; 4=Sentence formatter supported, but query for this sentence formatter is not supported; 5=Access denied, for sentence formatter requested; 6=Sentence not accepted due to bad checksum; 7=Sentence not accepted due to listener processing issue; 8,9=Reserved for future use; 10=Cannot perform the requested operation; 11=cannot fulfill request or command because of a problem with a data field in the sentence; 12 to 48=Reserved for future use; 49=Other reason as described in field 5.)
5. Negative acknowledgment's descriptive text

SSD - See "SSD - AIS ship static data" on page AP-10.

TRL - AIS transmitter non functioning log

\$\*\*TRL,x,x,x,x,x,xxxxxxx,hhmmss.ss,xxxxxxx,hhmmss.ss,x,\*hh<CR><LF>  
1 2 3 4 5 6 7 8

1. Total number of log entries (0 to 10)
2. Log entry number (1 to 10, NULL)
3. Sequential message identifier (0 to 9, NULL)
4. Switch off date (ddmmyyyy, NULL)
5. Switch off UTC time (000000 to 235959, NULL)
6. Switch on date (ddmmyy, NULL)
7. Switch on UTC time (000000 to 235959, NULL)
8. Reason code (1 to 5, NULL) 1=power off, 2=silent mode, 3=transmission switched off by channel management command, 4=equipment malfunction, 5=invalid configuration.

TXT - Text transmission

\$--TXT,xx,xx,xx,c--c\*hh<CR><LF>  
1 2 3 4

1. Total number of sentences (01 to 99)
2. Sentence number (01 to 99)
3. Text identifier
4. Text message

VDM - VHF data-link message

!AIVDM,x,x,x,a,s--s,x,\*hh<CR><LF>  
1 2 3 4 5 6

1. Total number of sentences needed to transfer the message (1 to 9)
2. Message sentence number (1 to 9)
3. Sequential message identifier (0 to 9, NULL)
4. AIS channel Number (A, B)
5. Encapsulated ITU-R M.1371 radio message (1 - 63 bytes)
6. Number of fill-bits (0 to 5)

VDO - AIS VHF data-link own-vessel report

!AIVDO,x,x,x,x,s--s,x,\*hh<CR><LF>  
1 2 3 4 5 6

1. Total number of sentences needed to transfer the message (1 to 9)
2. Message sentence number (1 to 9)
3. Sequential message identifier (0 to 9, NULL)
4. AIS channel Number (A, B, C, D, NULL)
5. Encapsulated ITU-R M.1371 radio message (1 to 63 bytes)
6. Number of fill-bits (0 to 5)

VER - Version

\$AIVER,x,x,aa,c-c,c-c,c-c,c-c,c-c,c-c,x,\*hh<CR><LF>  
1 2 3 4 5 6 7 8 9 10

1. Total number of sentences needed (1 to 9)
2. Sentence number (1 to 9)
3. Device type (AI)
4. Vendor ID
5. Unique Identifier
6. Manufacturer serial number
7. Model code (product code)
8. Software revision
9. Hardware revision
10. Sequential message identifier (0 to 9)

VSD - See "VSD - AIS voyage static data" on page AP-10.

**Inland AIS specific sentences**

**Input sentences and output sentences**

**PIWWIVD - Inland waterway voyage data**

\$PIWWIVD x, x, x, xx.xx, xx.xx, x, xxx, xxxx, xxx, x.x, x.x, x.x, x.x, hh<CR><LF>  
 1 2 3 4 5 6 7 8 9 10 11 12 13

1. Reporting rate: 0 to 15, NULL (See table to the right)
2. No. of blue cones: 0 to 3, 4=B-Flag, 5=unknown (default), NULL
3. Loaded/unloaded: 1=loaded, 2=unloaded, 0=not available (default), NULL
4. Inland draught: 0.01 to 20.00(m), 0=unknown (default), NULL
5. Air draught: 0.01 to 40.00(m), 0=unknown (default), NULL
6. No. of tugboats: 0 to 6, 7=unknown (default), NULL
7. No. of crew members: 0 to 254, 255=unknown (default), NULL
8. No. of passengers: 0 to 8190, 8191=unknown (default), NULL
9. No. of shipboard personnel: 0 to 254, 255=unknown (default), NULL
10. Convoy extension o bow: 0.0 to 800.0, NULL
11. Convoy extension to stern: 0.0 to 800.0, NULL
12. Convoy extension to port-side: 0.0 to 100.0, NULL
13. Convoy extension to starboard-side: 0.0 to 100.0, NULL

0	Return to Autonomous mode
1	10 minutes
2	6 minutes
3	3 minutes
4	1 minute
5	30 seconds
6	15 seconds
7	10 seconds
8	5 seconds
9	Next longer
10	Next shorter
11	2 seconds
12 to 15	Reserved for future use

**PIWWSSD - Inland waterway static ship data**

\$PIWWSSD CCCCCCCC, xxxx, xxxx, xxxx, x, x, x, x.x, x.x, x.x, x.x, hh<CR><LF>  
 1 2 3 4 5 6 7 8 9 10 11

1. ENI no. (00000000 to 99999999, NULL)
2. ERI ship type (0 to 9999, NULL)
3. Length of ship (0.0 to 800.0(m), NULL)
4. Beam of ship (0.0 to 100.0(m), NULL)
5. Quality of speed information (1: High, 0: Low, NULL)
6. Quality of course information (1: High, 0: Low, NULL)
7. Quality of heading information (1: High, 0: Low, NULL)
8. B value for internal position (0.0 to 800.0, NULL)
9. C value for internal position (0.0 to 100.0, NULL)
10. B value for external position (0.0 to 800.0, NULL)
11. C value for external position (0.0 to 100.0, NULL)

**PIWWVSD - Inland waterway voyage data**

\$PIWWVSD x, x, x, x, xx.xx, xx.xx, x, xxx, xxxx, xxx, hh<CR><LF>  
 1 2 3 4 5 6 7 8  
 9 10

1. Reporting rate. 1: SOLAS reporting rate, 2: 2s, 0: not available (default)
2. Blue sign, 1: Not set, 2: Set, 0: Not available (default)
3. Hazardous cargo 0-3, 4=B-Flag, 5=unknown (default)
4. Loaded/unloaded, 1=loaded, 2=unloaded, 0=not available (default)
5. Static draught, 0.01 to 20.00(m), 0=unknown (default)
6. Air draught, 0.01 to 40.00(m), 0=unknown (default)
7. No. of tugboats, 0 to 6, 7=unknown (default)
8. No. of crew members, 0 to 254, 255=unknown (default)
9. No. of passengers, 0 to 8190, 8191=unknown (default)
10. No. of shipboard personnel, 0 to 254, 255=unknown (default)

**Input only sentence**

**PIWWSPW - Inland AIS security password**

\$PIWWSPW a, x, c - - - c, x, hh<CR><LF>  
 1 2 3 4

1. Mode (E: Password input, C: Password change)
2. Password level (1: Maintenance password, 2: User password)
3. Password (At least 6 characters)
4. Valid time (0 and 1 to 60 (s))

**Output only sentence**

PIWWSPR - Inland AIS security password response

\$PIWWSPR a, x, x, x, hh<CR><LF>  
1 2 3 4

1. Mode (E: Password input, C: Password change)
2. Password level (1: Maintenance password, 2: User password, NULL)
3. Valid time (0 to 60 (s), NULL)
4. Status (0: Pass, 1: Fail)

# PACKING LIST FA-170-E-5-FCC

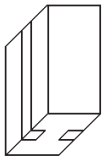
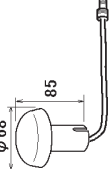

05ES-X-9859-8 1/1





NAME	OUTLINE	DESCRIPTION/CODE No.	Q'TY
ユニット			
トランスポンダ` 部箱詰品		FA-1701-E-FCC	1
TRANSPONDER UNIT IN BOX		000-029-979-00	
表示部一式箱詰品		FA-1702*	1
MONITOR UNIT COMPLETE SET		000-030-012-00	
アンテナ		GPA-017S	1
ANTENNA UNIT		000-192-734-11	

## 予備品

NAME	OUTLINE	DESCRIPTION/CODE No.	Q'TY
予備品			
予備品		SP05-06501	1
SPARE PARTS		001-426-300-00	







## 工事材料



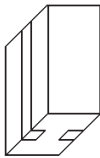
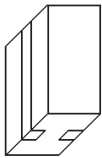

NAME	OUTLINE	DESCRIPTION/CODE No.	Q'TY
ケーブル(組品)			
CABLE ASSEMBLY		Z-AWG25X4P-SB L050	1
ケーブル組品		001-426-390-00	
CABLE ASSEMBLY		TNC-PS/PS-3D-L15M-R	1
工事材料		001-173-110-10	
INSTALLATION MATERIALS		CP05-13601	1
INSTALLATION MATERIALS		001-426-480-00	

NAME	OUTLINE	DESCRIPTION/CODE No.	Q'TY
工事材料			
INSTALLATION MATERIALS		CP05-13621	1
		001-546-360-00	
<b>図書 DOCUMENT</b>			
取扱説明書(英)		OME-44900-*	1
OPERATOR'S MANUAL (EN)		000-191-089-1*	
操作要領書(多言語)		MLG-44900-*	1
OPERATOR'S GUIDE (EN)		000-191-091-1*	
装備要領書(英)		IME-44900-*	1
INSTALLATION MANUAL (EN)		000-191-093-1*	

# PACKING LIST FA-170-E-5-DB1

05ES-X-9854-5 1/1

NAME	OUTLINE	DESCRIPTION/CODE No.	Q'TY
<b>ユニット UNIT</b>			
トランスポンダ` 部箱詰品		FA-1701-*	1
TRANSPONDER UNIT IN BOX		000-029-977-00 **	
表示部一式箱詰品		FA-1702*	1
MONITOR UNIT COMPLETE SET		000-030-012-00 **	
分配器		DB-1	1
DISTRIBUTER UNIT		000-053-854-00	
<b>予備品 SPARE PARTS</b>			
予備品		SP05-06501	1
SPARE PARTS		001-426-300-00	
<b>工事材料 INSTALLATION MATERIALS</b>			
ケーブル(組品)		Z-AWG25X4P-SB L050	1
CABLE ASSEMBLY		001-426-390-00	
工事材料		CP05-13601	1
INSTALLATION MATERIALS		001-426-480-00	
工事材料		CP24-00101	1
INSTALLATION MATERIALS		005-950-730-00	

NAME	OUTLINE	DESCRIPTION/CODE No.	Q'TY
工事材料		CP05-13621	1
INSTALLATION MATERIALS		001-546-360-00	
<b>図書 DOCUMENT</b>			
取扱説明書(英)		OME-44900-*	1
OPERATOR'S MANUAL (EN)		000-191-089-1*	
操作要領書(多言語)		MLG-44900-*	1
OPERATOR'S GUIDE (EN)		000-191-091-1*	
装備要領書(英)		IME-44900-*	1
INSTALLATION MANUAL (EN)		000-191-093-1*	

コード番号末尾の[\*\*]は、選択品の代表コードを表します。  
CODE NUMBER ENDING WITH "\*\*" INDICATES THE CODE NUMBER OF REPRESENTATIVE MATERIAL.

(略図の寸法は、参考値です。DIMENSIONS IN DRAWING FOR REFERENCE ONLY.)



PACKING LIST  
FA-170-E-5-GPA

05ES-X-9857 -7 1/1  
A-3

NAME	OUTLINE	DESCRIPTION/CODE No.	QTY
<b>ユニット</b>			
トランスポンダ 部箱詰品		FA-1701-*	1
TRANSPOUNDER UNIT IN BOX		000-029-977-00 **	
表示部一式箱詰品		FA-1702*	1
MONITOR UNIT COMPLETE SET		000-030-012-00 **	
<b>予備品</b>			
アンテナ		GPA-017S	1
ANTENNA UNIT		000-192-734-11	
<b>SPARE PARTS</b>			
予備品		SP05-06501	1
SPARE PARTS		001-426-300-00	
<b>工事材料</b>			
ケーブル (組品)		Z-AMG25XAP-SB L050	1
CABLE ASSEMBLY		001-426-390-00	
工事材料		CP05-13601	1
INSTALLATION MATERIALS		001-426-480-00	
工事材料		CP05-13621	1
INSTALLATION MATERIALS		001-546-360-00	
<b>図書</b>			
取扱説明書 (英)		IME-44900-*	1
OPERATOR'S MANUAL (EN)		000-191-089-1*	
操作要領書 (多言語)		MLG-44900-*	1
OPERATOR'S GUIDE (EN)		000-191-091-1*	
装備要領書 (英)		IME-44900-*	1
INSTALLATION MANUAL (EN)		000-191-093-1*	

コード番号末尾の[\*]\*\*]は、選択品の代表コードを表します。  
CODE NUMBER ENDING WITH ".\*" INDICATES THE CODE NUMBER OF REPRESENTATIVE MATERIAL.

(略図の寸法は、参考値です。DIMENSIONS IN DRAWING FOR REFERENCE ONLY.)

C4490-Z07-H

PACKING LIST  
FA-170-E-V, FA-170-E-HK-V

05ES-X-9856 -2 1/1  
A-4

NAME	OUTLINE	DESCRIPTION/CODE No.	QTY
<b>ユニット</b>			
トランスポンダ 部		FA-1701-*	1
TRANSPOUNDER UNIT		000-029-978-00 **	
表示部一式箱詰品		FA-1702-V/-HK-V	1
MONITOR UNIT COMPLETE SET		000-029-458-00 **	
<b>工事材料</b>			
工事材料		CP05-13601	1
INSTALLATION MATERIALS		001-426-480-00	
<b>図書</b>			
取扱説明書 (英)		OME-44900-*	1
OPERATOR'S MANUAL (EN)		000-191-089-1*	
操作要領書 (多言語)		MLG-44900-*	1
OPERATOR'S GUIDE (EN)		000-191-091-1*	
装備要領書 (英)		IME-44900-*	1
INSTALLATION MANUAL (EN)		000-191-093-1*	

コード番号末尾の[\*]\*\*]は、選択品の代表コードを表します。  
CODE NUMBER ENDING WITH ".\*" INDICATES THE CODE NUMBER OF REPRESENTATIVE MATERIAL.

(略図の寸法は、参考値です。DIMENSIONS IN DRAWING FOR REFERENCE ONLY.)

C4490-Z06-C

# PACKING LIST

05ES-X-9851 -1 1/1  
A-5

FA-170-J/E

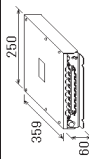
NAME	OUTLINE	DESCRIPTION/CODE No.	QTY
ユニット トランスミッタ部 TRANSPONDER UNIT		FA-1701-* 000-029-976-00 **	1

コード番号末尾の「\*」は、選択品の代表コードを表します。  
CODE NUMBER ENDING WITH "\*" INDICATES THE CODE NUMBER OF REPRESENTATIVE MATERIAL.



(略図の寸法は、参考値です。 DIMENSIONS IN DRAWING FOR REFERENCE ONLY.)

C4490-Z01-B

# PACKING LIST

24AA-X-9853 -6 1/1  
A-6

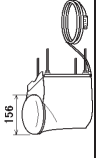
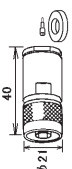
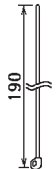
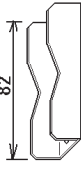
GVA-100, GVA-100-T

NAME	OUTLINE	DESCRIPTION/CODE No.	QTY
ユニット 複合空中線部 GPS/VHF COMBINED ANTENNA		GVA-100 000-053-810-00 **	1
<b>工事材料</b> INSTALLATION MATERIALS			
コネクタ CONNECTOR		N-P-8DSFA 000-167-921-10	2
ケーブル CABLE TIE		CY-200HT 000-162-191-10	2
アンテナ取付金具 ANTENNA BRACKET		24-003-3015-0 R0HS 100-302-670-10	2
フラットワッシャー FLAT WASHER		M8 SUS304 000-167-464-10	4
六角ナット HEX. NUT		M8 SUS304 000-167-479-10	8

1.コード番号末尾の「\*」は、選択品の代表型式/コードを表します。  
CODE NUMBER ENDING WITH "\*" INDICATES THE CODE NUMBER OF REPRESENTATIVE MATERIAL.

型式/コード番号が2段の場合、下段より上段に代わる過渡期品であり、どちらかが入っています。なお、品質は変わりません。  
TWO TYPES AND CODES MAY BE LISTED FOR AN ITEM. THE LOWER PRODUCT MAY BE SHIPPED IN PLACE OF THE UPPER PRODUCT. QUALITY IS THE SAME.  
(略図の寸法は、参考値です。 DIMENSIONS IN DRAWING FOR REFERENCE ONLY.)

C4417-Z03-E



表1 TABLE 1

寸法区分 (mm) DIMENSION	公差 (mm) TOLERANCE
$L \leq 50$	$\pm 1.5$
$50 < L \leq 100$	$\pm 2.5$
$100 < L \leq 500$	$\pm 3$

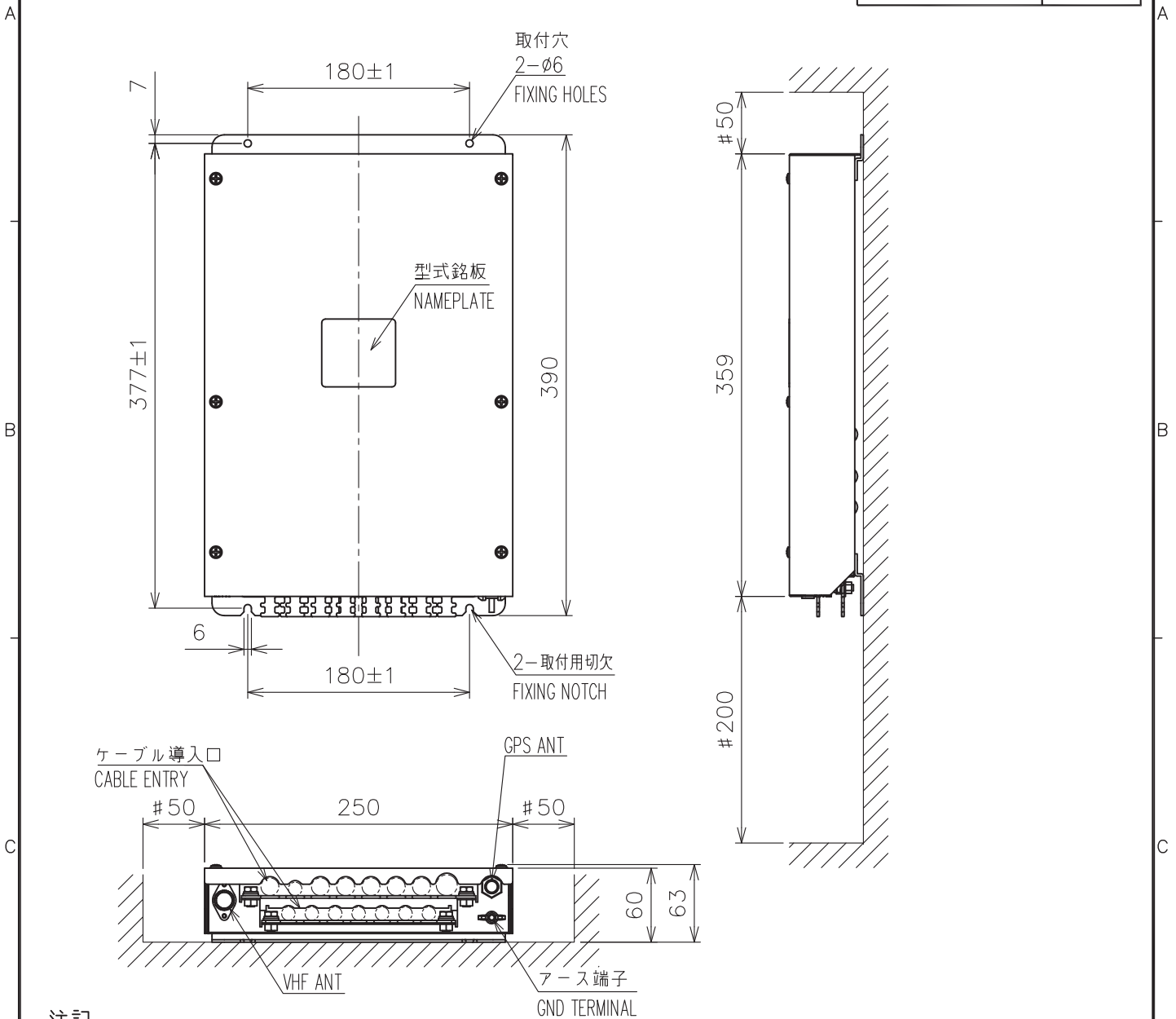

注記

- 1) 指定外の寸法公差は表1による。
- 2) #印寸法は最小サービス空間寸法とする。
- 3) 取付用ネジはタッピンネジ呼び径5×20、またはM5ボルトを使用のこと。

NOTE

1. TABLE 1 INDICATES TOLERANCE OF DIMENSIONS WHICH IS NOT SPECIFIED.
2. #: MINIMUM SERVICE CLEARANCE.
3. USE TAPPING SCREWS  $\phi 5 \times 20$  OR M5 BOLTS FOR FIXING THE UNIT.

DRAWN 15/Oct/2015 T.YAMASAKI		TITLE FA-1701
CHECKED 15/Oct/2015 H.MAKI		名称 トランスポンダ部
APPROVED 15/Oct/2015 H.MAKI	FA-170	外寸図
SCALE 1/5	MASS 3.0 $\pm 10\%$ kg	NAME TRANSPONDER UNIT
DWG. No. C4490-G01-B	REF. No. 05-109-250G-2	OUTLINE DRAWING

表1 TABLE 1

寸法区分 (mm) DIMENSION	公差 (mm) TOLERANCE
L ≤ 50	±1.5
50 < L ≤ 100	±2.5
100 < L ≤ 500	±3

型式銘板  
NAMEPLATE

取付穴  
4-φ5.5  
FIXING HOLES

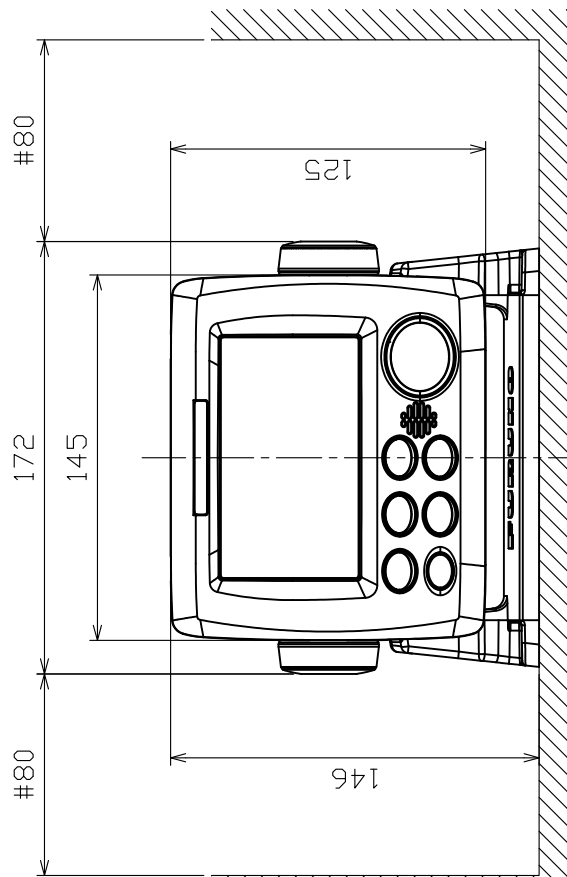
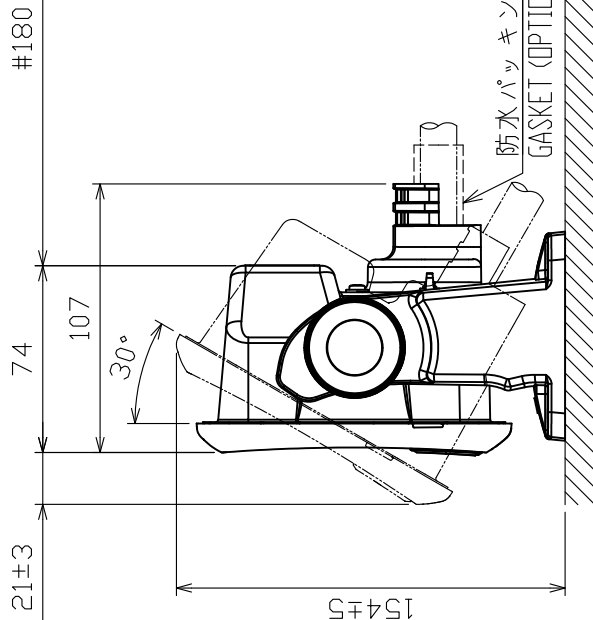
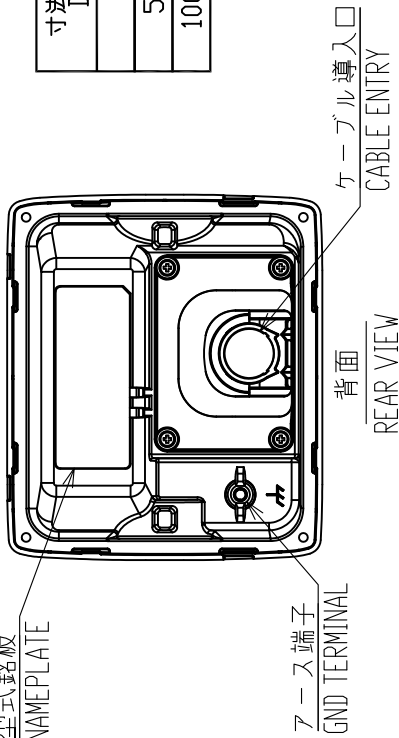

注記

- 1) 指定外寸法公差は表1による。
- 2) #印寸法は、最小サービスクリアランスとする。
- 3) 取付用ネジはトラスチックピンネジ呼び径5×20を使用のこと。

NOTE

1. TABLE 1 INDICATES TOLERANCE OF DIMENSIONS WHICH IS NOT SPECIFIED.
2. # MINIMUM SERVICE CLEARANCE.
3. USE TAPPING SCREWS φ5x20 FOR FIXING THE UNIT.

DRAWN	25/Sep/2018	I.YAMASAKI	TITLE	FA-170C
CHECKED	25/Sep/2018	H.MAKI	名称	表示部 (卓上装備)
APPROVED	27/Sep/2018	H.MAKI	FA-170	外形図
SCALE	1/3	質量はケーブル・アンプ・ジョーンを含む。 MASS DOES NOT INCLUDE CABLE/OPTION.	NAME	MONITOR UNIT (TABLETOP MOUNT)
DWG.No.	C4490-602-D	REF.No.	05-109-350G-3	OUTLINE DRAWING

表1 TABLE 1

寸法区分 (mm) DIMENSION	公差 (mm) TOLERANCE
L ≤ 50	±1.5
50 < L ≤ 100	±2.5
100 < L ≤ 500	±3

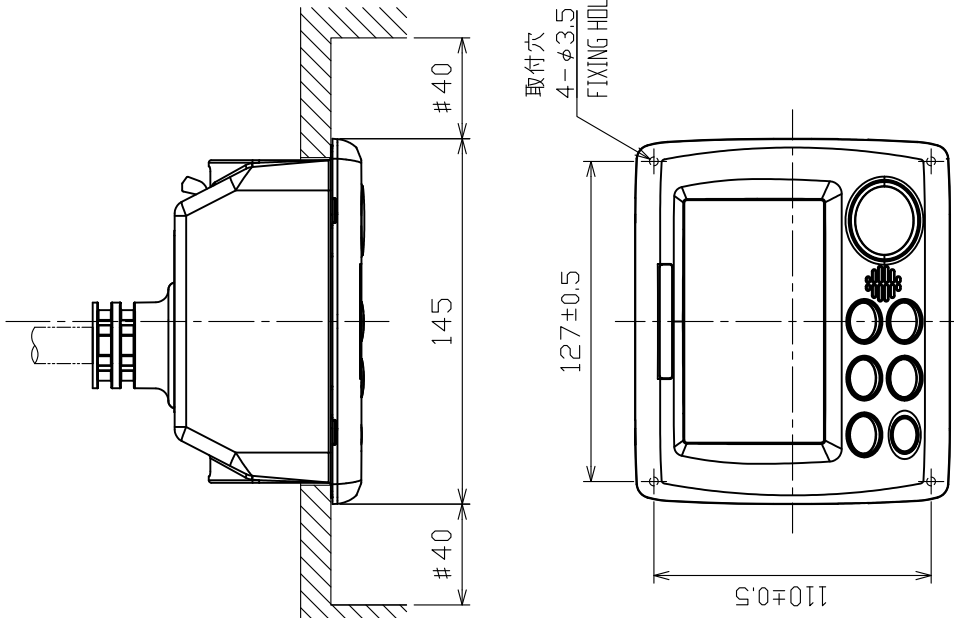
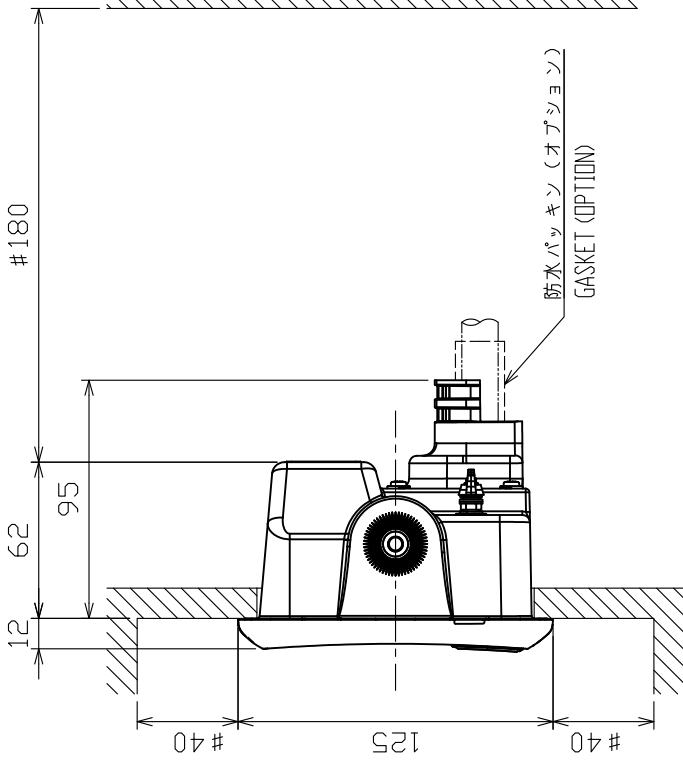
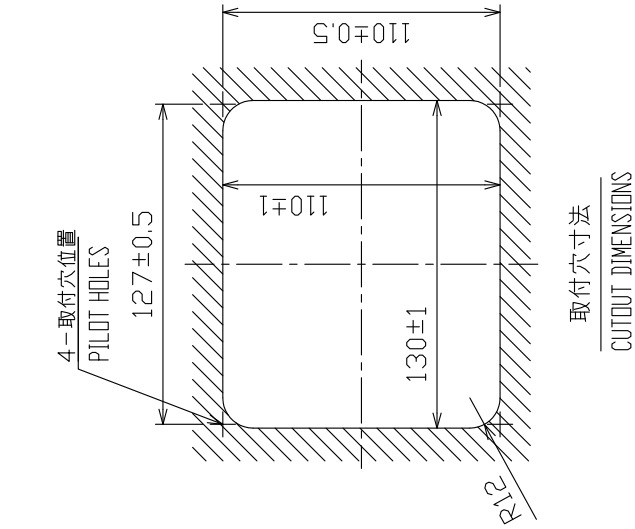
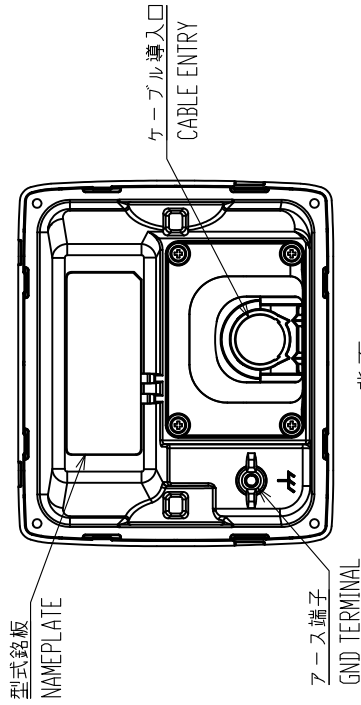

注 記

- 1) 指定外寸法公差は表 1 による。
- 2) # 印寸法は、最小サービスクリアランスとする。
- 3) 取付用ネジはナバタツ呼び径 3×20 を使用のこと。

NOTE

1. TABLE 1 INDICATES TOLERANCE OF DIMENSIONS WHICH IS NOT SPECIFIED.
2. #: MINIMUM SERVICE CLEARANCE.
3. USE TAPPING SCREWS φ3x20 FOR FIXING THE UNIT.

DRAWN	25/Sep/2018	I. YAMASAKI	TITLE	FA-1702
CHECKED	25/Sep/2018	H. MAKI	名称	表示部 (埋込装備)
APPROVED	25/Sep/2018	H. MAKI	外寸図	
SCALE	1/3	MASS 0.6 kg	NAME	MONITOR UNIT (FLUSH MOUNT)
FIG.No.	C4490-G03-D	05-109-351G-3	OUTLINE DRAWING	

表 1 TABLE 1

寸法区分 (mm) DIMENSION	公差 (mm) TOLERANCE
L ≤ 50	±1.5
50 < L ≤ 100	±2.5
100 < L ≤ 500	±3

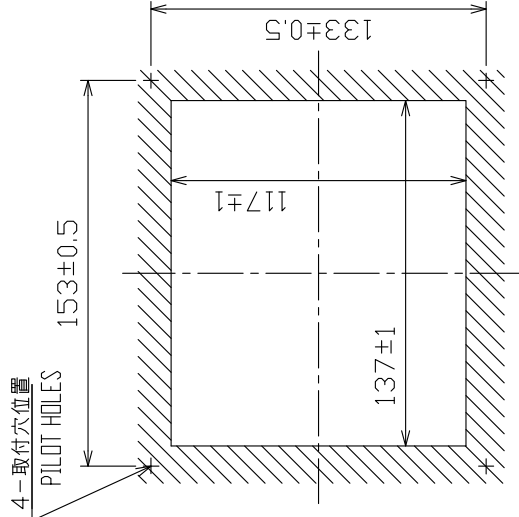
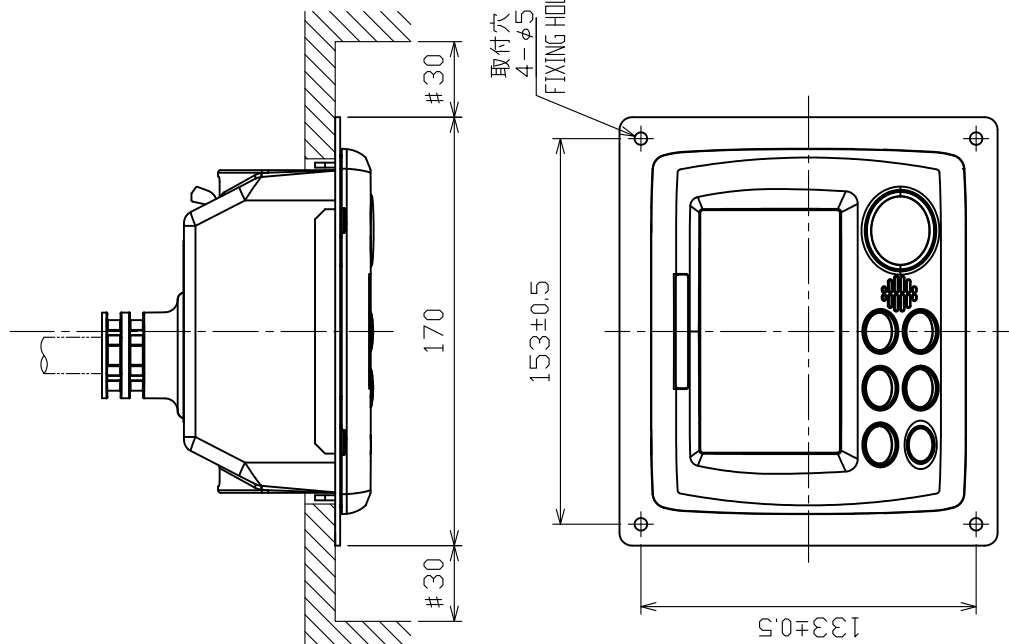
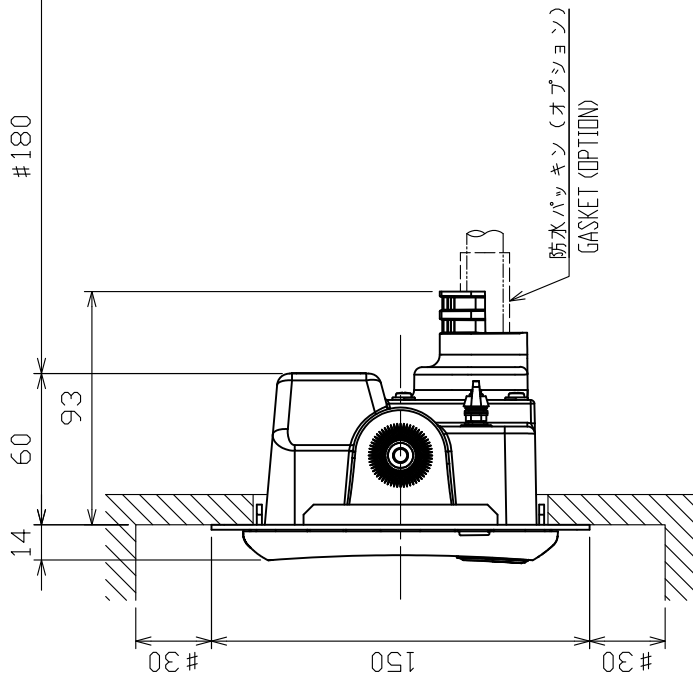
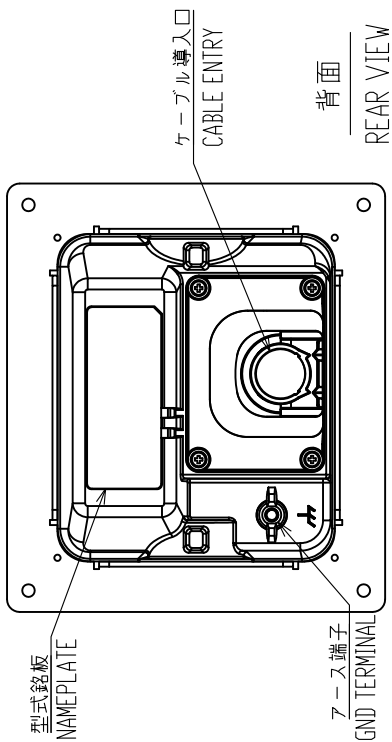

取付穴寸法  
CUTOUT DIMENSIONS

注 記

- 指定外寸法公差は表 1 による。
  - # 印寸法は、最小サービスクリアランスとする。
  - 取付用ネジはトラスター呼び径 4 × 16 を使用のこと。
- NOTE
- TABLE 1 INDICATES TOLERANCE OF DIMENSIONS WHICH IS NOT SPECIFIED.
  - # MINIMUM SERVICE CLEARANCE.
  - USE TAPPING SCREWS φ4x16 FOR FIXING THE UNIT.

DRAWN	25/Sep/2018	I. YAMASAKI	TITLE	FA-1702
CHECKED	25/Sep/2018	H. MAKI	名称	表示部 (パネル装備)
APPROVED	28/Sep/2018	H. MAKI	外寸図	MONITOR UNIT (PANEL MOUNT)
SCALE	1/3	質量 0.65 kg 寸法はケーブル・オプションを含みます。 MASS DOES NOT INCLUDE CABLE/OPTION.	NAME	OUTLINE DRAWING
DWG. No.	C4490-G04-D	REF. No.	05-109-352G-3	

表1 TABLE 1

寸法区分 (mm) DIMENSION	公差 (mm) TOLERANCE
L ≤ 50	±1.5
50 < L ≤ 100	±2.5
100 < L ≤ 500	±3

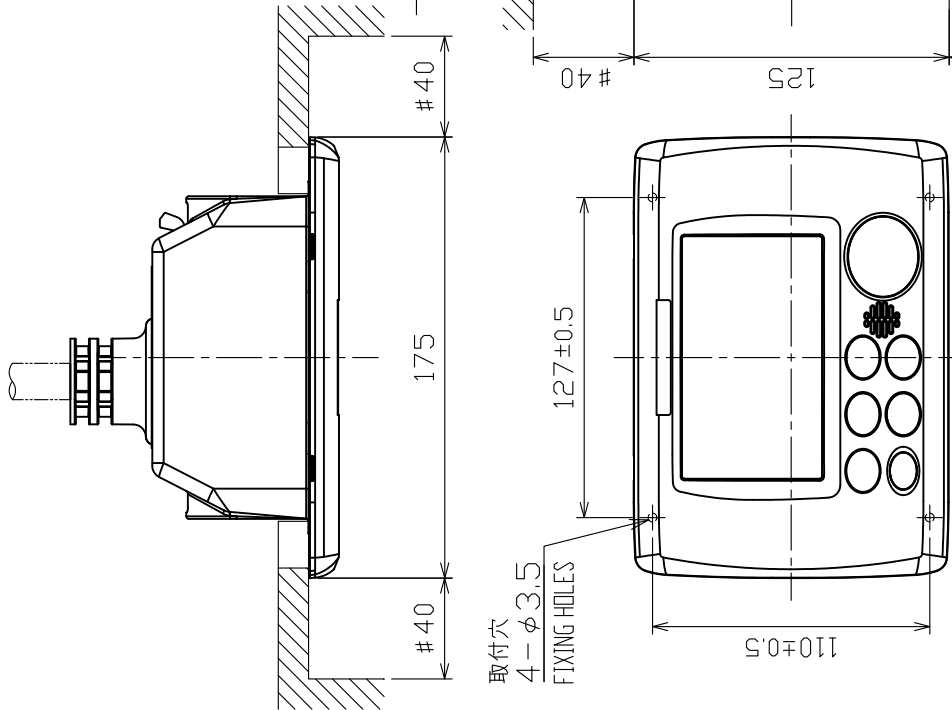
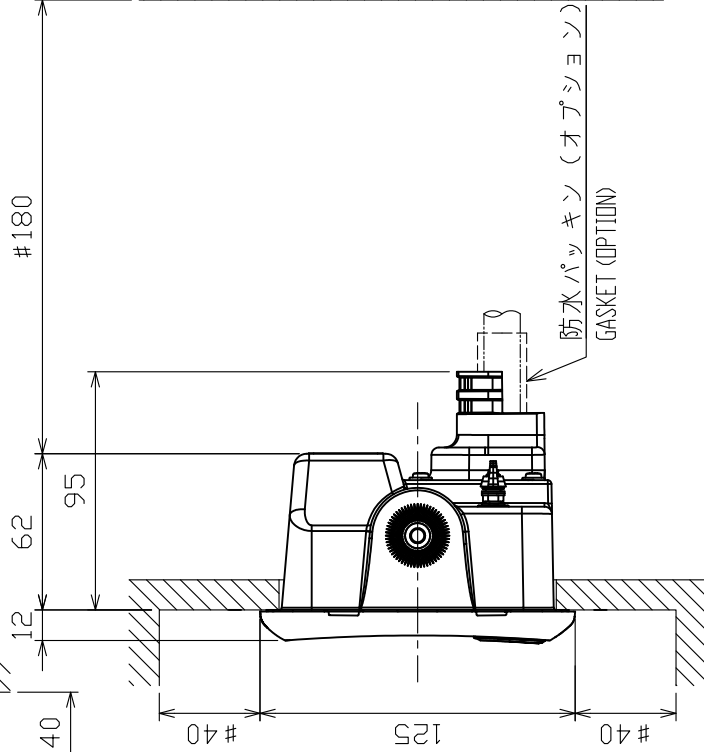
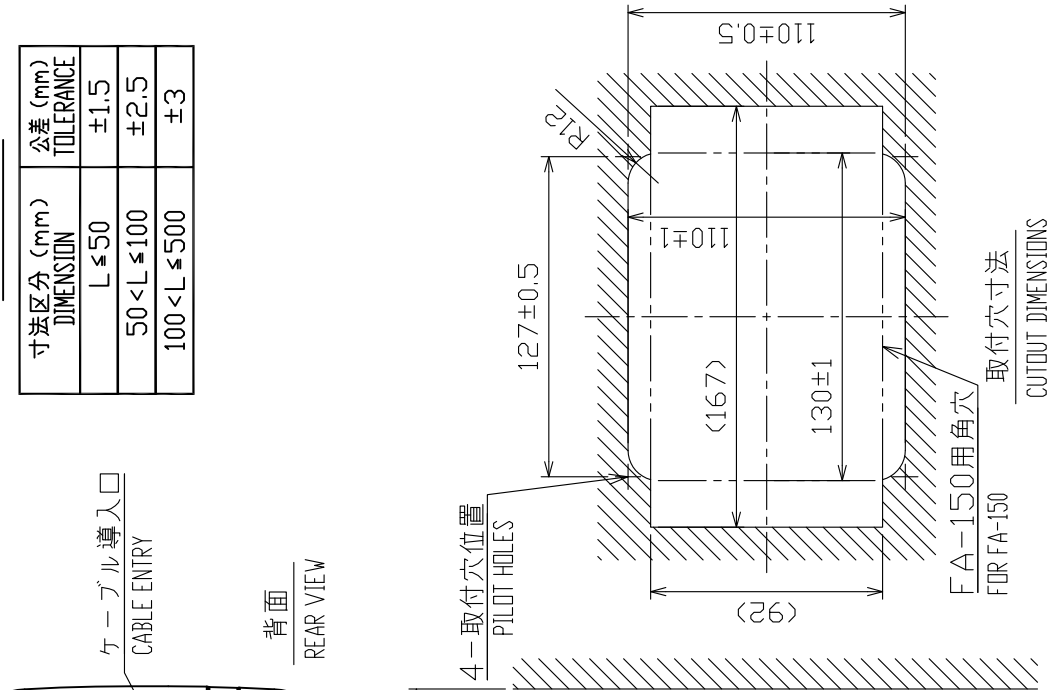
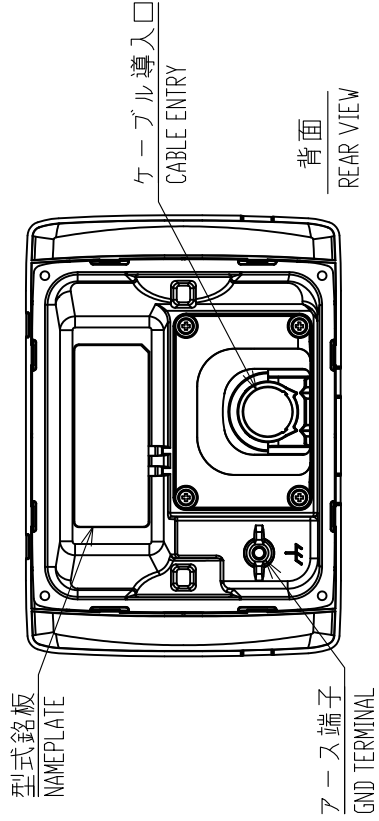

注 記

- 指定外寸法公差は表1による。
- #印寸法は、最小サービスマン寸法とする。
- 取付用ネジはナベタツピネジ呼び径3×20を使用のこと。

NOTE

- TABLE 1 INDICATES TOLERANCE OF DIMENSIONS WHICH IS NOT SPECIFIED.
- # MINIMUM SERVICE CLEARANCE.
- USE TAPPING SCREWS φ3x20 FOR FIXING THE UNIT.

DRAWN	25/Sep/2018	I.YAMASAKI	TITLE	FA-170Z
CHECKED	25/Sep/2018	H.MAKI	名称	表示部 (パネル装備、FA-150換装)
APPROVED	28/Sep/2018	H.MAKI	FA-170	外寸図
SCALE	1/3	MASS 0.6 10% kg	質量はケーブル・オプションを含みます。 MASS DOES NOT INCLUDE CABLE/OPTION.	MONITOR UNIT (FOR FA-150 PANEL REMOUNT)
IMG No.	C4490-G06-C	REF.No.	05-109-353G-2	OUTLINE DRAWING



表 1 TABLE 1

寸法区分 (mm) DIMENSION	公差 (mm) TOLERANCE
L ≤ 50	± 1.5
50 < L ≤ 100	± 2.5
100 < L ≤ 500	± 3

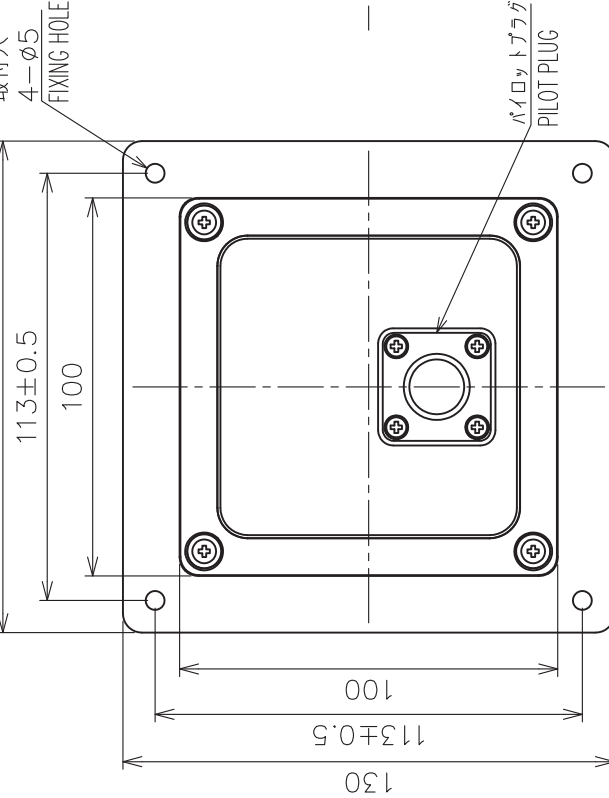
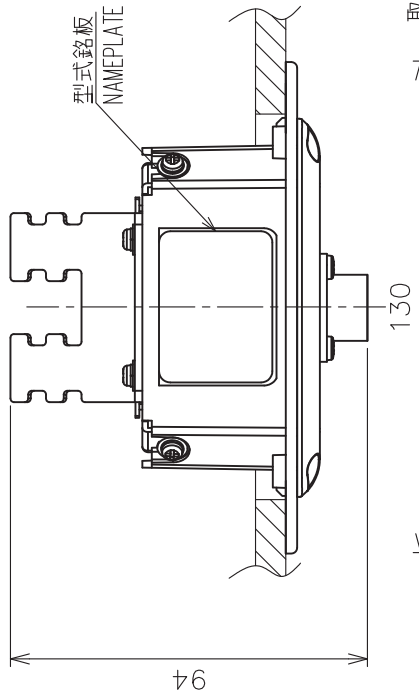
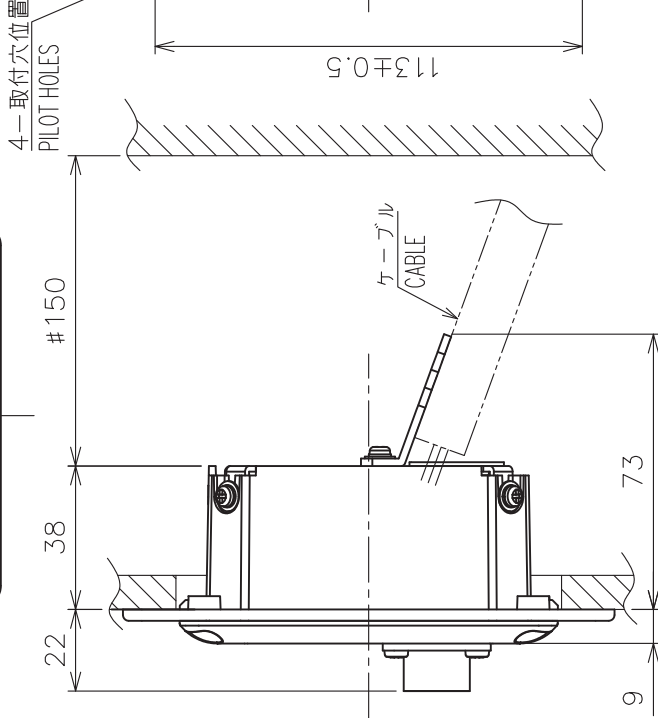
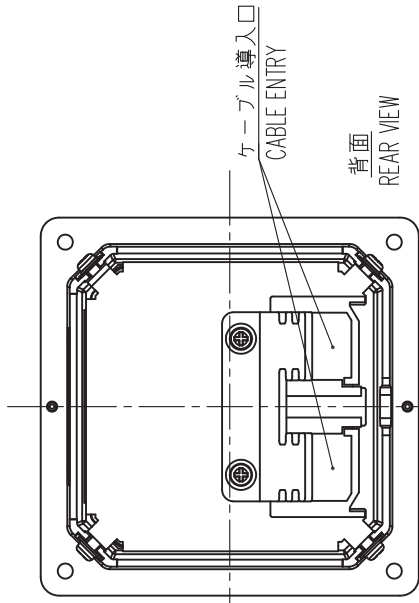

注 記

- 1) 指定外の寸法公差は表 1 による。
- 2) # 印寸法は最小サービスマージン寸法とする。
- 3) 取付にはトラスタップピッチネジ呼び径 4 × 1.6 を使用のこと。

NOTE

1. TABLE 1 INDICATES TOLERANCE OF DIMENSIONS WHICH IS NOT SPECIFIED.
2. # MINIMUM SERVICE CLEARANCE.
3. USE TAPPING SCREWS φ4x1.6 FOR FIXING THE UNIT.

DRAWN	19/Oct/2015	T.YAMASAKI	TITLE	FA-1703
CHECKED	20/Oct/2015	H.MAKI	名称	パイロットプラグユニット
APPROVED	20/Oct/2015	H.MAKI	外寸図	
SCALE	1/2	質量 0.28 kg #104 質量はケーブルを含みず。 MASS DOES NOT INCLUDE CABLE.	NAME	PILOT PLUG UNIT
DWG.No.	C4490-G05-C	REV.No.	05-109-451G-2	OUTLINE DRAWING

寸法区分 (mm) DIMENSION	公差 (mm) TOLERANCE
L ≤ 50	± 1.5
50 < L ≤ 100	± 2.5
100 < L ≤ 500	± 3

表 1 TABLE 1

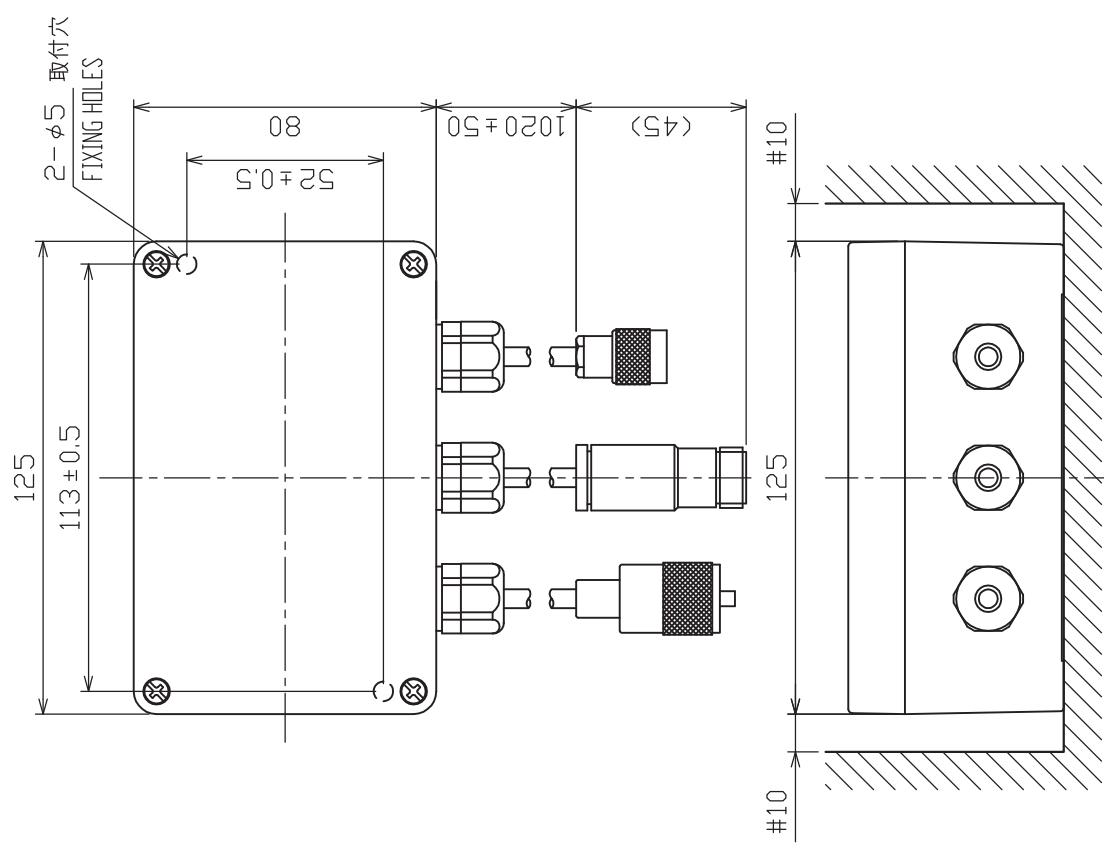

- 注 記
- 1) #印寸法は最小サービスイ空間寸法とする。
  - 2) 指定外の寸法公差は表 1 による。
  - 3) 取付用ネジは + ナベタップピンネジ 4 x 3.0 を使用のこと。
- NOTE
1. # RECOMMENDED SERVICE CLEARANCE.
  2. TABLE 1 INDICATES TOLERANCE OF DIMENSIONS.
  3. USE TAPPING SCREWS 4x3.0 FOR FIXING THE UNIT.

DRAWN	Jan. 9 '03	T. YAMASAKI	TITLE	DB-1
CHECKED	Jan. 9 '03	Y. KIMURA	名称	分配器
APPROVED	Jan. 9 '03	<i>y. Kimura</i>	外寸図	FA-100
SCALE	1/2	MASS 0.85 kg	NAME	DISTRIBUTOR
DWG No.	C4417-G04-C		24-003-320G-4	OUTLINE DRAWING

表2 TABLE 2

アンテナ型式 ANTENNA MODEL	FAB-151D	CX4-3/FEC
L(mm)	1245±15	1356±15
質量 MASS (kg±10%)	3.3	3.4

表1 TABLE 1

寸法区分 (mm) DIMENSION	公差 (mm) TOLERANCE
$L \leq 50$	±1.5
$50 < L \leq 100$	±2.5
$100 < L \leq 500$	±4
$500 < L \leq 1000$	±5
$1000 < L \leq 2000$	

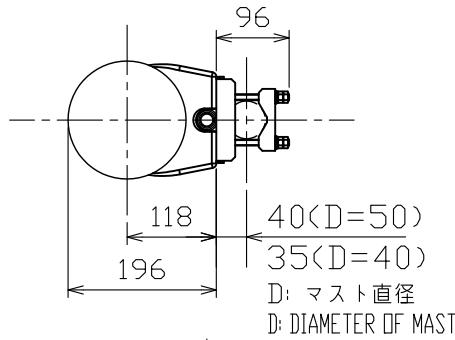

A

B

C

D

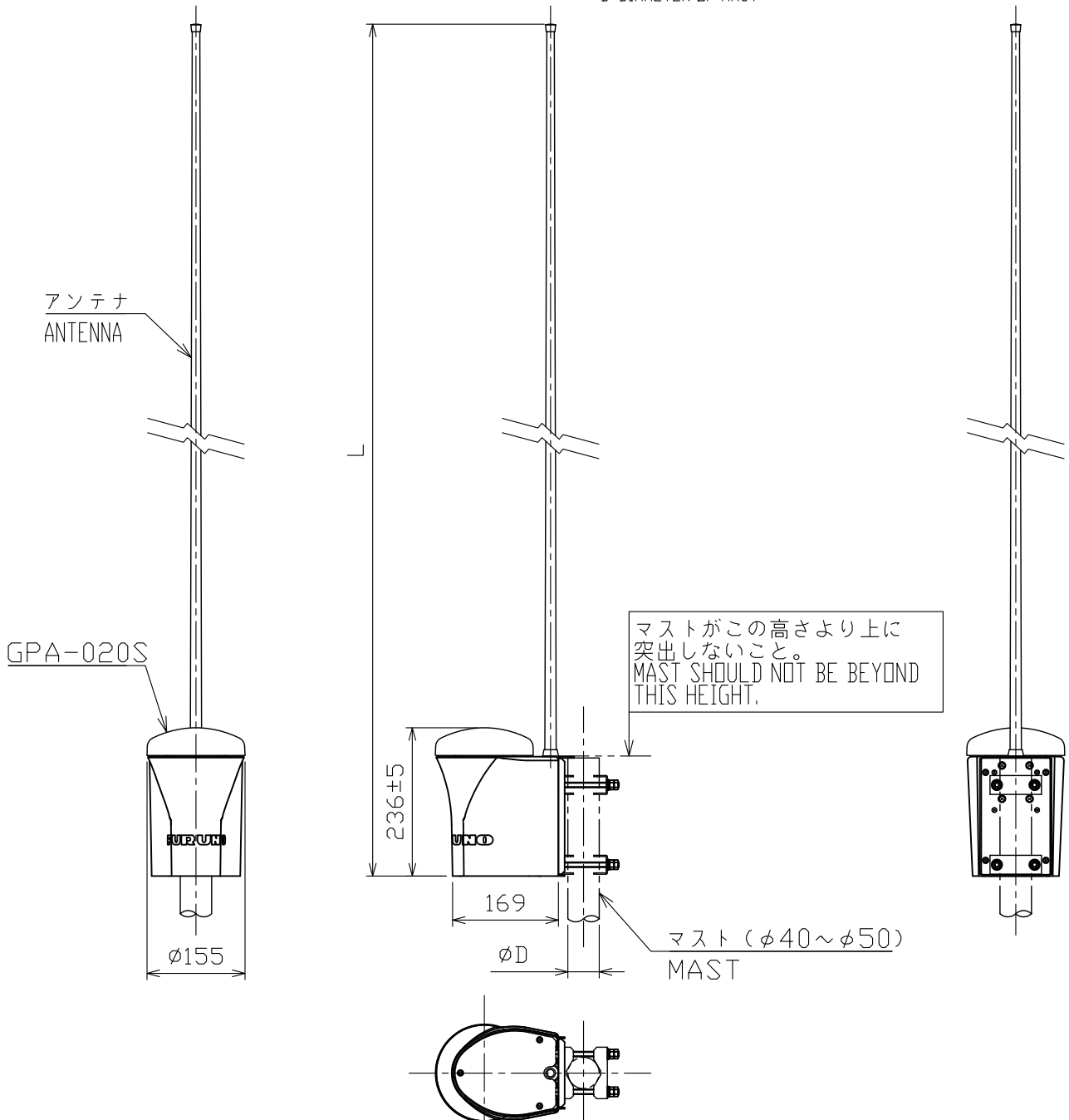

注 記 1) 指定外の寸法公差は表1による。

NOTE 1. TABLE 1 INDICATES TOLERANCE OF DIMENSIONS WHICH IS NOT SPECIFIED.

DRAWN 16/Nov/2018 T.YAMASAKI		TITLE GVA-100-T
CHECKED 16/Nov/2018 H.MAKI		名称 GPS/VHF 複合空中線部
APPROVED 20/Nov/2018 H.MAKI	FA-100/50/150/170	外寸図
SCALE 1/10	MASS 表2参照 TABLE 2	NAME GPS/VHF COMBINED ANTENNA
DWG. No. C4417-G02-K	REF. No. 24-003-301G-4	OUTLINE DRAWING

表2 TABLE 2

アンテナ型式 ANTENNA MODEL	FAB-151D	CX4-3/FEC
L(mm)	1245±15	1356±15
質量 MASS (kg±10%)	5.1	5.2

表1 TABLE 1

寸法区分 (mm) DIMENSION	公差 (mm) TOLERANCE
$L \leq 50$	±1.5
$50 < L \leq 100$	±2.5
$100 < L \leq 500$	±3
$500 < L \leq 1000$	±4
$1000 < L \leq 2000$	±5

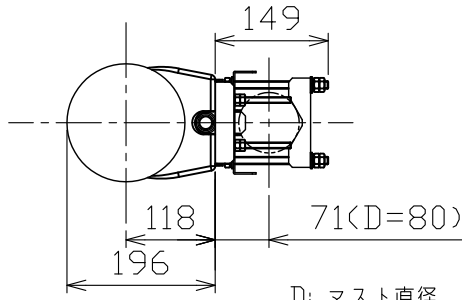

D: マスト直径  
D: DIAMETER OF MAST

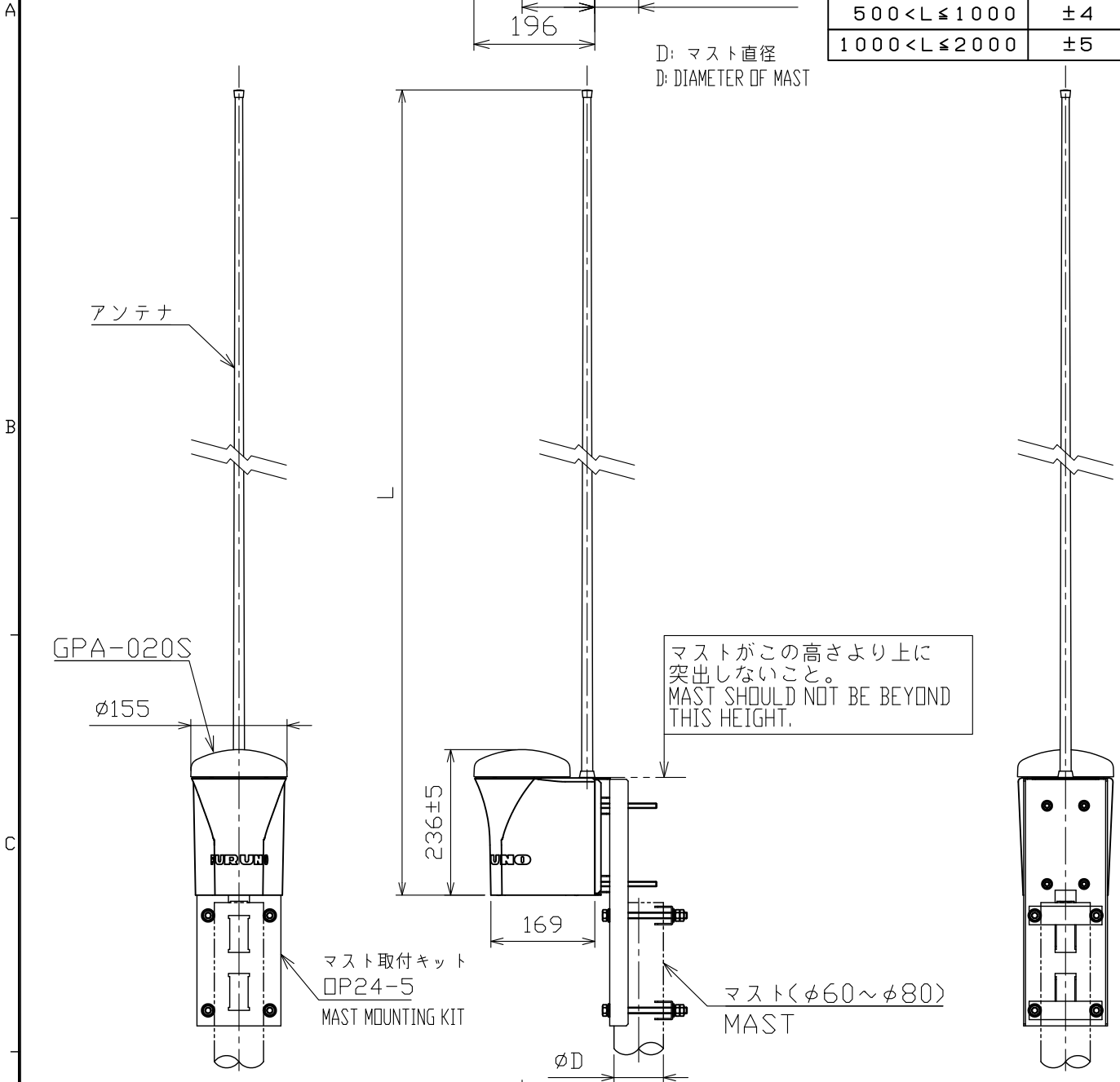

注記

1) 指定外の寸法公差は表1による。

NOTE

1. TABLE 1 INDICATES TOLERANCE OF DIMENSIONS WHICH IS NOT SPECIFIED.

DRAWN 19/Nov/2018 T.YAMASAKI	TITLE GVA-100-T
CHECKED 19/Nov/2018 H.MAKI	名称 GPS/VHF 複合空中線部 (取付キット)
APPROVED 20/Nov/2018 H.MAKI	外寸図
SCALE 1/10	NAME GPS/VHF COMBINED ANTENNA (MAST MOUNTING KIT)
DWG. No. C4417-G10-E	REF. No. 24-003-303G-4
MASS 表2参照 TABLE 2	OUTLINE DRAWING

A

B

C

D



表1 TABLE 1

寸法区分(mm) DIMENSION	公差(mm) TOLERANCE
L ≤ 50	±1.5
50 < L ≤ 100	±2.5
100 < L ≤ 500	±3

1-14UNS1B

ねじ山数 (25.4mmにつき) : 14  
 ピッチ : 1.8143 mm  
 オネジ有効長さ : 19 mm以上  
 オネジ有効径 : 24.17mm

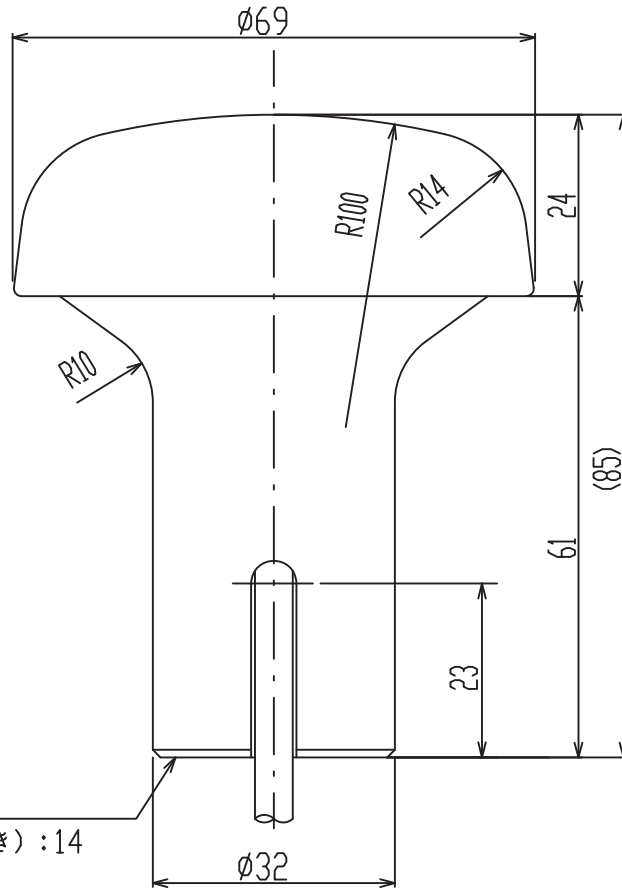
THREAD PER 25.4mm (1 INCH): 14  
 PITCH: 1.8143 mm  
 THREAD LENGTH: 19 mm OR MORE  
 PITCH DIAMETER: 24.17mm



表2 TABLE 2

型式 TYPE	ケーブル長(m) CABLE LENGTH	プラグ PLUG	質量(kg±10%) MASS
GPA-017	10	TNC-P-3	0.6
GPA-017S	0.2	TNC-J-3	0.15

注記

指定外の寸法公差は表1による。

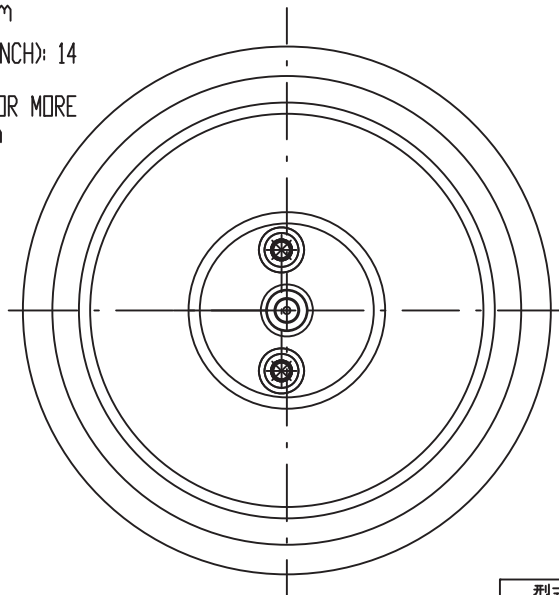
NOTE

TABLE 1 INDICATES TOLERANCE OF DIMENSIONS WHICH IS NOT SPECIFIED.

DRAWN Mar. 27 '07 T.YAMASAKI	TITLE GPA-017/017S
CHECKED Mar. 27 '07 T.TAKENO	名称 空中線部
APPROVED Mar. 27 '07 R.Esumi	外寸図
SCALE 1/1 MASS TABLE 2 表2参照	NAME ANTENNA UNIT
DWG.No. C4384-G04- L	OUTLINE DRAWING

表1 (Table1)

寸法区分 (mm) Dimension	公差 (mm) Tolerance
$L \leq 50$	$\pm 1.5$
$50 < L \leq 100$	$\pm 2.5$
$100 < L \leq 500$	$\pm 3$
$500 < L \leq 1000$	$\pm 4$
$1000 < L \leq 2000$	$\pm 5$

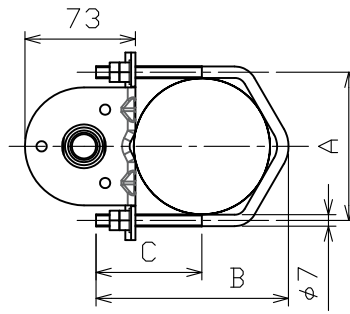

品目	ITEM	型式 MODEL	材質 (JIS) MATERIAL
アンテナ金具	FIXING PLATE	N173F/174F	SUS316
座金	WASHER		SUS316
ナット	NUT		C3603B
Uボルト	U-BOLT		SUS316
座金・ナット	WASHER/NUT	M8	SUS316

表3 (Table3)

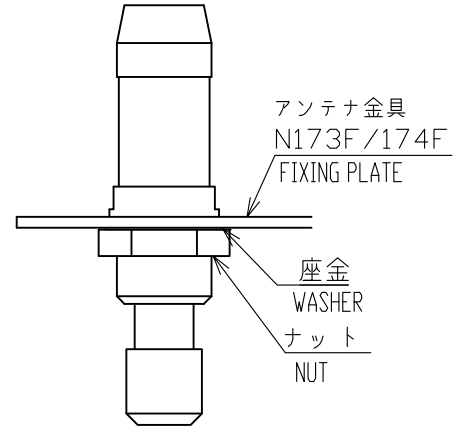

取付部詳細 (尺度:1/2)  
DETAIL FOR FIXING (SCALE:1/2)

\*: 斜線部は自己融着テープを巻きさらにビニールテープを巻いて防水処理をすること。  
SEAL WITH SELF-BONDING TAPE AND PVC TAPE FOR WATERTIGHT.

マストがこの高さより上に突出しないこと。  
MAST SHOULD NOT BE BEYOND THIS HEIGHT.



表2 (Table2)

アンテナ金具型式 FIXING PLATE	Uボルト型式 U-BOLT TYPE	適合マスト径 MAST DIAMETER	A	B	C
N173F/FEC	412-0051-01	φ49 - φ90	98	127	70
N174F/FEC	412-0024-02	φ30 - φ61	69	117	83

注記 1) 指定外の寸法公差は表1による。

NOTE 1. TABLE 1 INDICATES TOLERANCE OF DIMENSIONS WHICH IS NOT SPECIFIED.

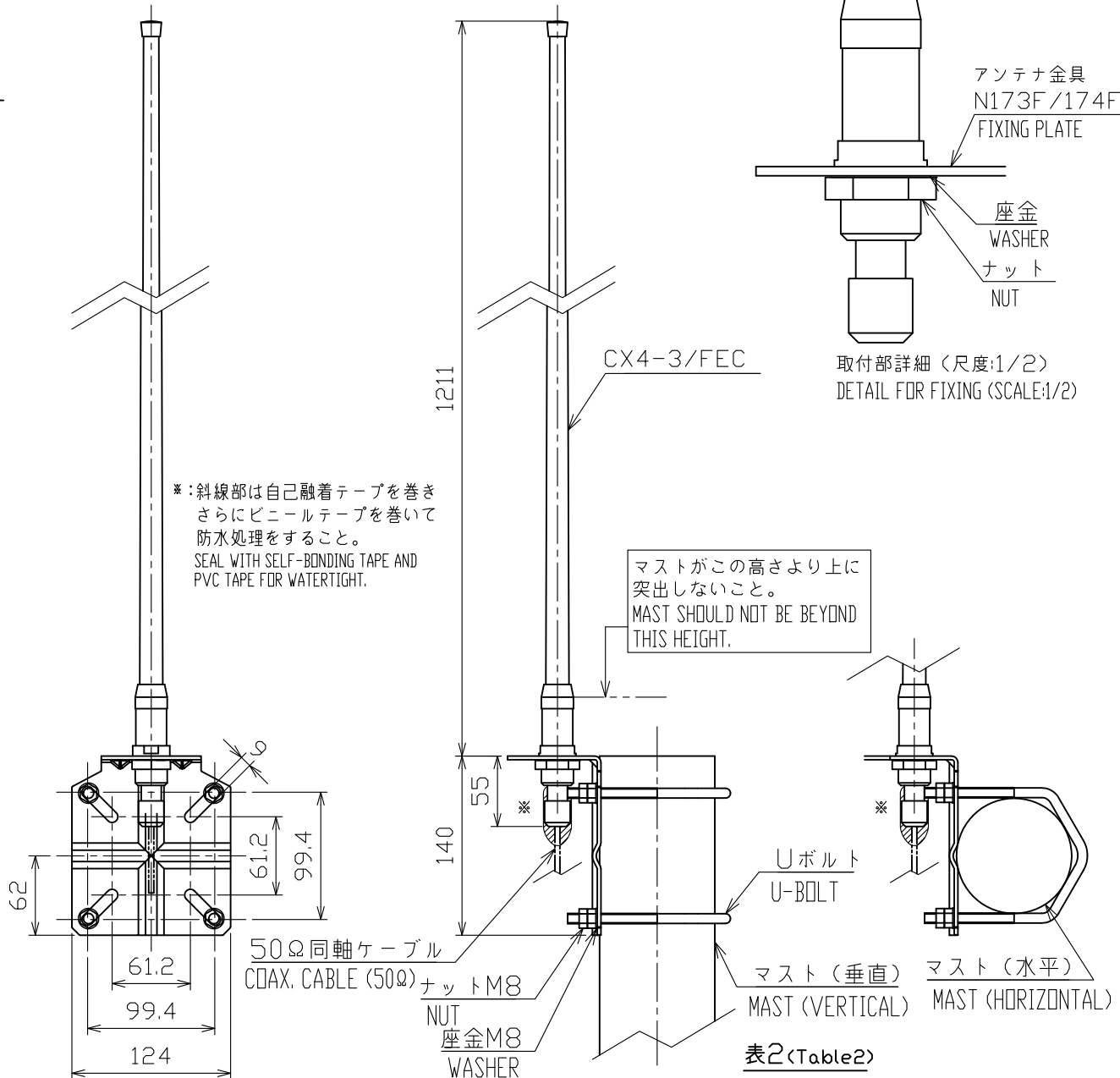
DRAWN	10/Jan/2019	T.YAMASAKI	TITLE	CX4-3/FEC		
CHECKED	10/Jan/2019	H.MAKI	名称	アンテナ		
APPROVED	11/Jan/2019	H.MAKI	外寸図			
SCALE	1/5	MASS ±10% 1.2 kg	質量は取付金具を含まず。 MASS DOES NOT INCLUDE FIXTURE.	NAME	ANTENNA	
DWG. No.	C5013-G04-F		REF. No.	05-104-355G-2		
				OUTLINE DRAWING		

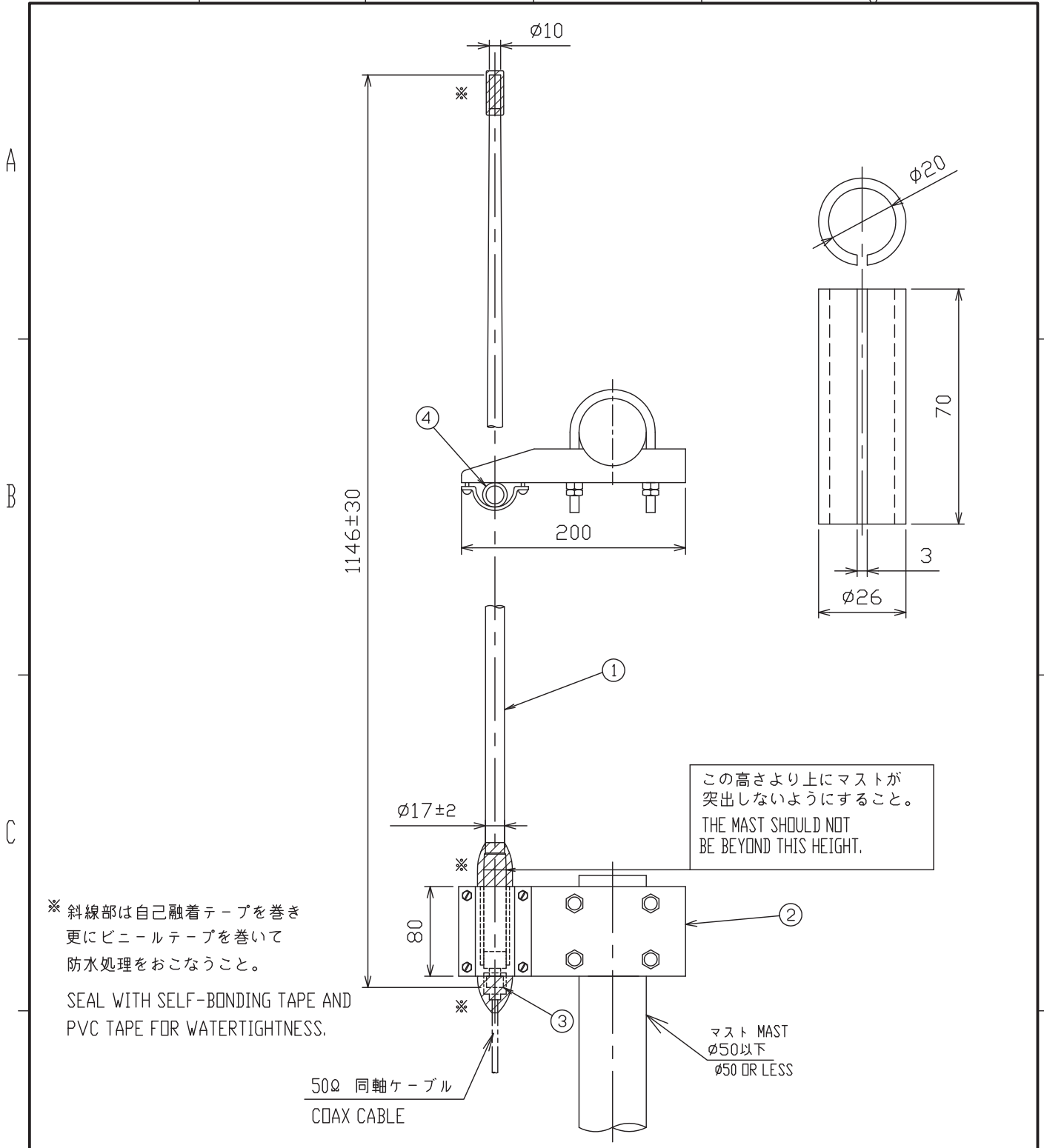

品番 ITEM	品名 NAME	材質 MATERIAL	数量 Q.TY	図番 DWG.No.	摘要 REMARKS
4	固定用パイプ LINER PIPE	硬質塩ビ VINYL CHLORIDE	1		
3	同軸コネクタ COAX. CONNECTOR		1		M-R
2	アンテナ取付金具 ANTENNA BRACKET	SUS	1 式 SET	4-310071	0.6kg
1	アンテナ棒 ANTENNA ELEMENT	FRP	1		0.25kg

DRAWN	4/Aug/2017	I.YAMASAKI	TITLE	FAB-151D
CHECKED	4/Aug/2017	H.MAKI	名称	150MHz ホイップアンテナ
APPROVED	10/Aug/2017	H.MAKI		外寸図
SCALE	1/5	MASS 0.85 ±10% kg	NAME	150MHz WHIP ANTENNA
DWG.No.	C5013-019-L	4-110718		OUTLINE DRAWING

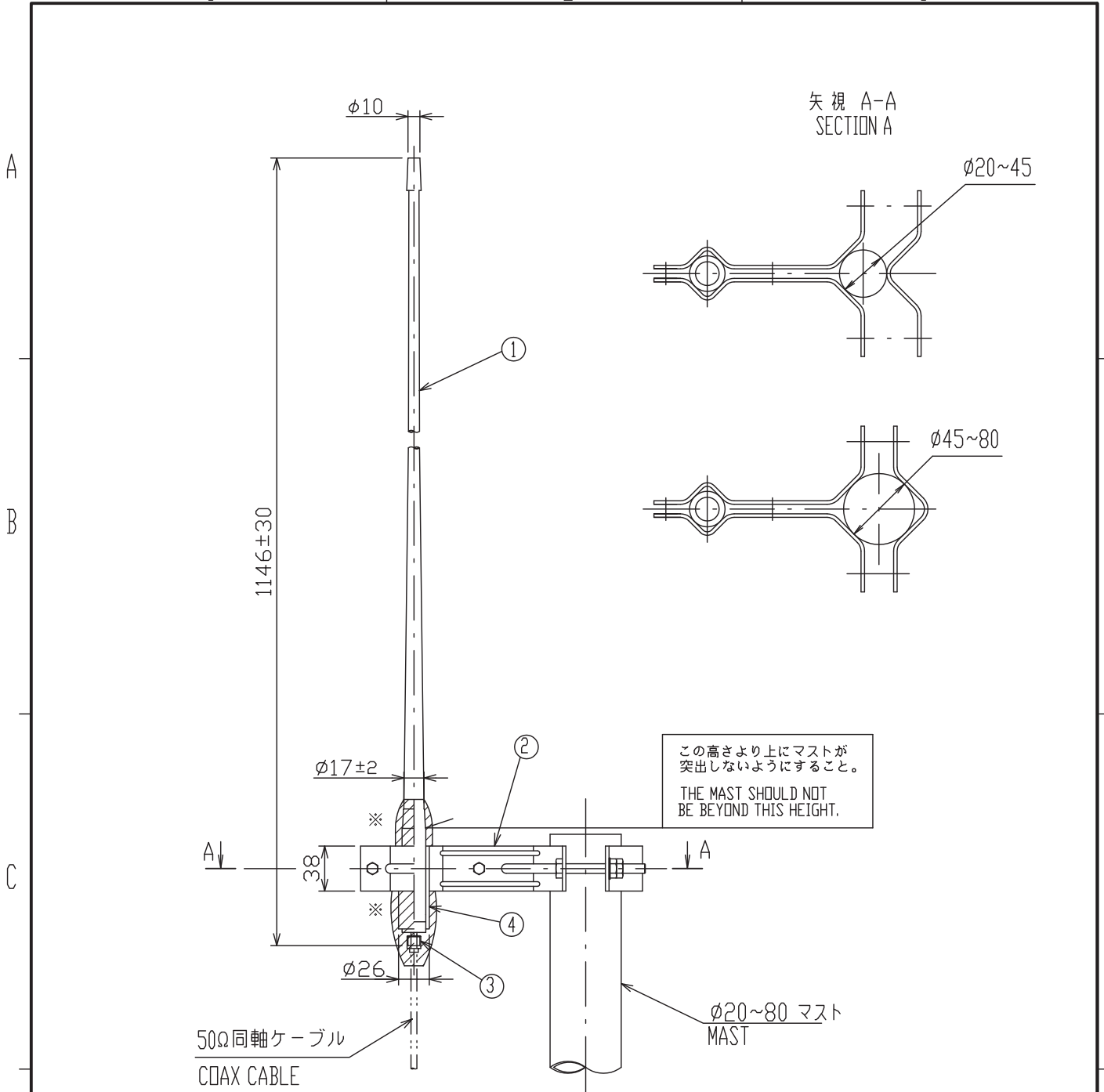

※： 斜線部は自己融着テープを巻き  
さらにビニールテープを巻いて  
防水処理を行うこと。  
SEAL WITH SELF-BONDING TAPE AND  
PVC TAPE FOR WATERTIGHTNESS.

4	固定用パイプ LINEAR PIPE	硬質塩ビ VINYL CHLORIDE	1		
3	同軸コネクタ COAX. CONNECTOR		1		M-R
2	アンテナ取付金具 ANTENNA BRACKET	SUS316L	1 式 SET	M-15AS	t2.5
1	アンテナ棒 ANTENNA ELEMENT	FRP	1	FAB-151D	0.25 kg
品番 ITEM	品名 NAME	材質 MATERIAL	数量 QTY	図番 DWG. No.	摘要 REMARKS

DRAWN	4/Aug/2017 T.YAMASAKI	TITLE	FAB-151D + M-15AS1
CHECKED	4/Aug/2017 H.MAKI	名称	150MHzホイップアンテナ(取付金具)
APPROVED	10/Aug/2017 H.MAKI	外寸図	
SCALE	1/5 MASS 0.7 ±10% kg	質量は取付金具を含む。 MASS INCLUDES BRACKET.	NAME
DWG. No.	C5011-042-G	REF. No.	OUTLINE DRAWING



**取付位置**  
MOUNTING LOCATION

他の機器のアンテナから下の図の距離以上離す。  
THIS FIGURE SHOWS THE SEPARATION DISTANCES FROM OTHER ANTENNAS TO AVOID MUTUAL INTERFERENCE.

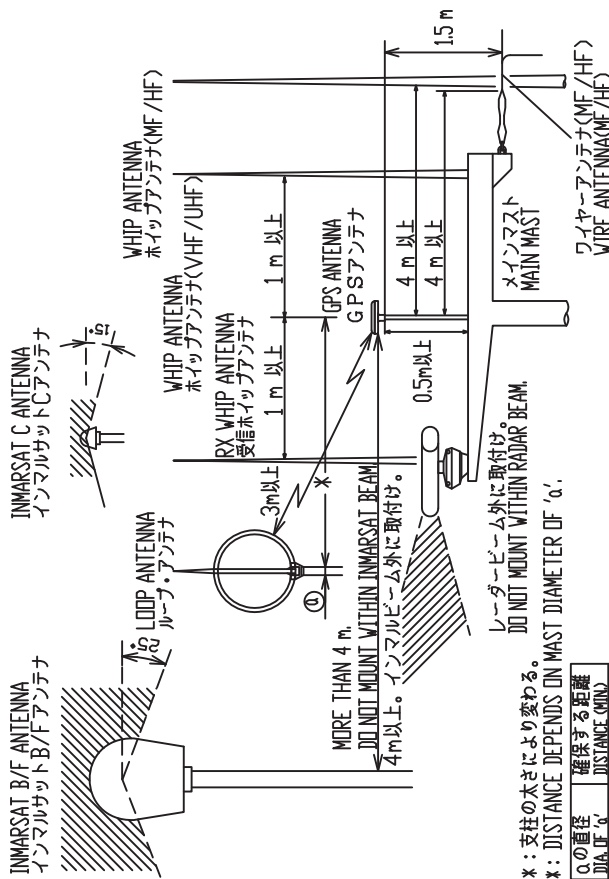

**B) スタンションやパルピットにつけるとき**

レール用アンテナベース No.13-RC5160  
(取付可能レール直径:φ19~φ32)  
(コード番号:000-806-114)

**HANDRAIL MOUNTING**

USE HANDRAIL MOUNTING BASE No.13-RC5160  
(CODE No.000-806-114, OPTION).  
THE DIAMETER OF THE HANDRAIL MAY BE  
FROM φ19mm TO φ32mm.

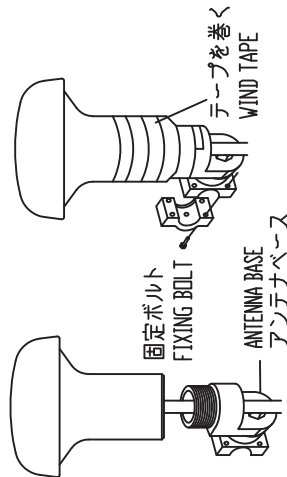

- 注記 1) パイプやアンテナベースはアンテナユニットにねじ込んだ後に固定する。  
2) アンテナを固定するときはパイプ(アンテナベース)をアンテナにねじ込むこと。  
アンテナ脚をねじるとコネクタ部やケーブルに無理がかかり、故障の原因となる。
- NOTE 1. FASTEN PIPE(ANTENNA BASE) TO ANTENNA UNIT FIRST THEN FIX THEM TO MAST OR HANDRAIL.  
2. WHEN FIXING ANTENNA, TURN PIPE OR ANTENNA BASE; NOT THE ANTENNA.  
TURNING THE ANTENNA MAY TWIST THE CABLE AND PLACE STRESS ON CONNECTOR.

**A) マストへの取付け**  
MAST MOUNTING

α) マスト取付金具CP20-0111(工事材料)でマストに固定する。  
USE MAST MOUNTING KIT CP20-0111.

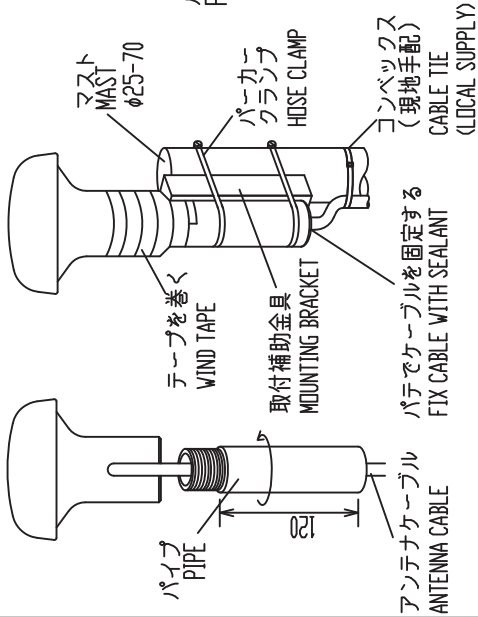

β) パイプのみを使うとき  
USE A PIPE ONLY.

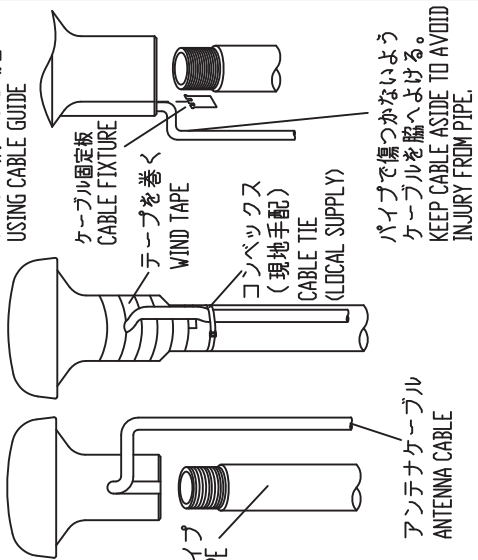

ケーブル溝のある場合  
USING CABLE GUIDE

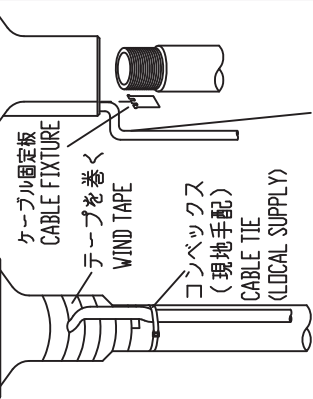

パイプで傷つかないよう  
ケーブルを脇へよける。  
KEEP CABLE ASIDE TO AVOID  
INJURY FROM PIPE.

**C) 取付ける場所が傾斜しているとき** ANTENNA BASE MOUNTING

オプションのアンテナベースを使う。  
USE OPTIONAL ANTENNA BASE.

アンテナベース基部  
MOUNTING DIMENSIONS OF ANTENNA BASE.

傾斜 INCLINATION	5° - 33°	32° - 65°	65° - 98°
取付方法 MOUNTING METHOD			
アンテナベース型式 ANT. BASE TYPE	直型アンテナベース RIGHT ANGLE ANTENNA BASE No.13-QA330	L型アンテナベース L-TYPE ANTENNA BASE No.13-QA310	L型アンテナベース L-TYPE ANTENNA BASE No.13-QA310
コード番号 CODE No.	000-803-239	000-803-240	000-803-240

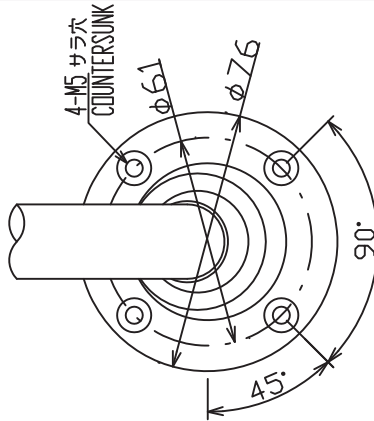

DRAWN 14/MAY/2014 T.YAMASAKI  
CHECKED 14/MAY/2014 H.MAKI  
APPROVED 15/May/2014 H.MAKI  
SCALE MASS  
Drawing No. C4384-Y01-F

TITLE GPA series  
名称 空中線部  
装備要領図  
NAME ANTENNA UNIT  
INSTALLATION PROCEDURE

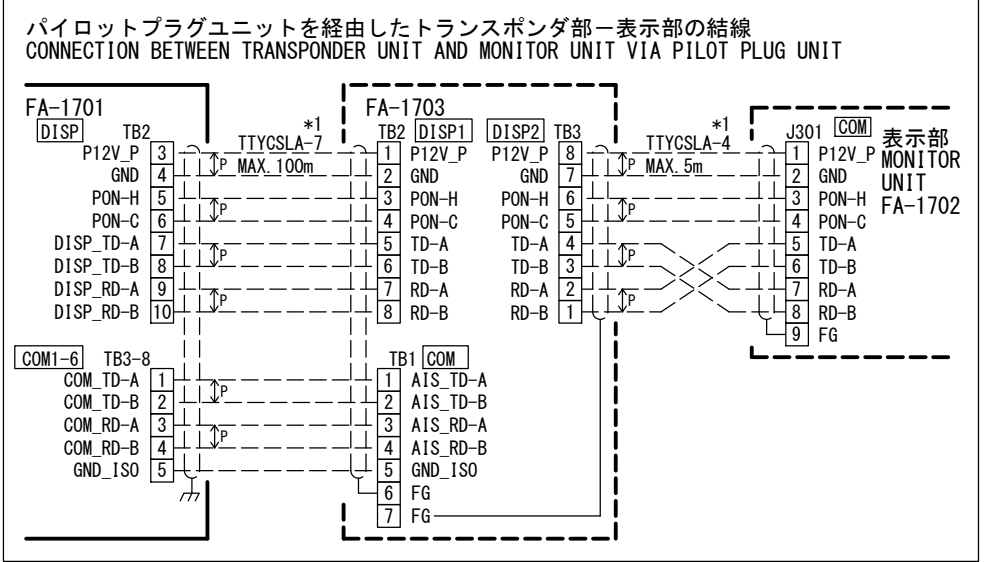
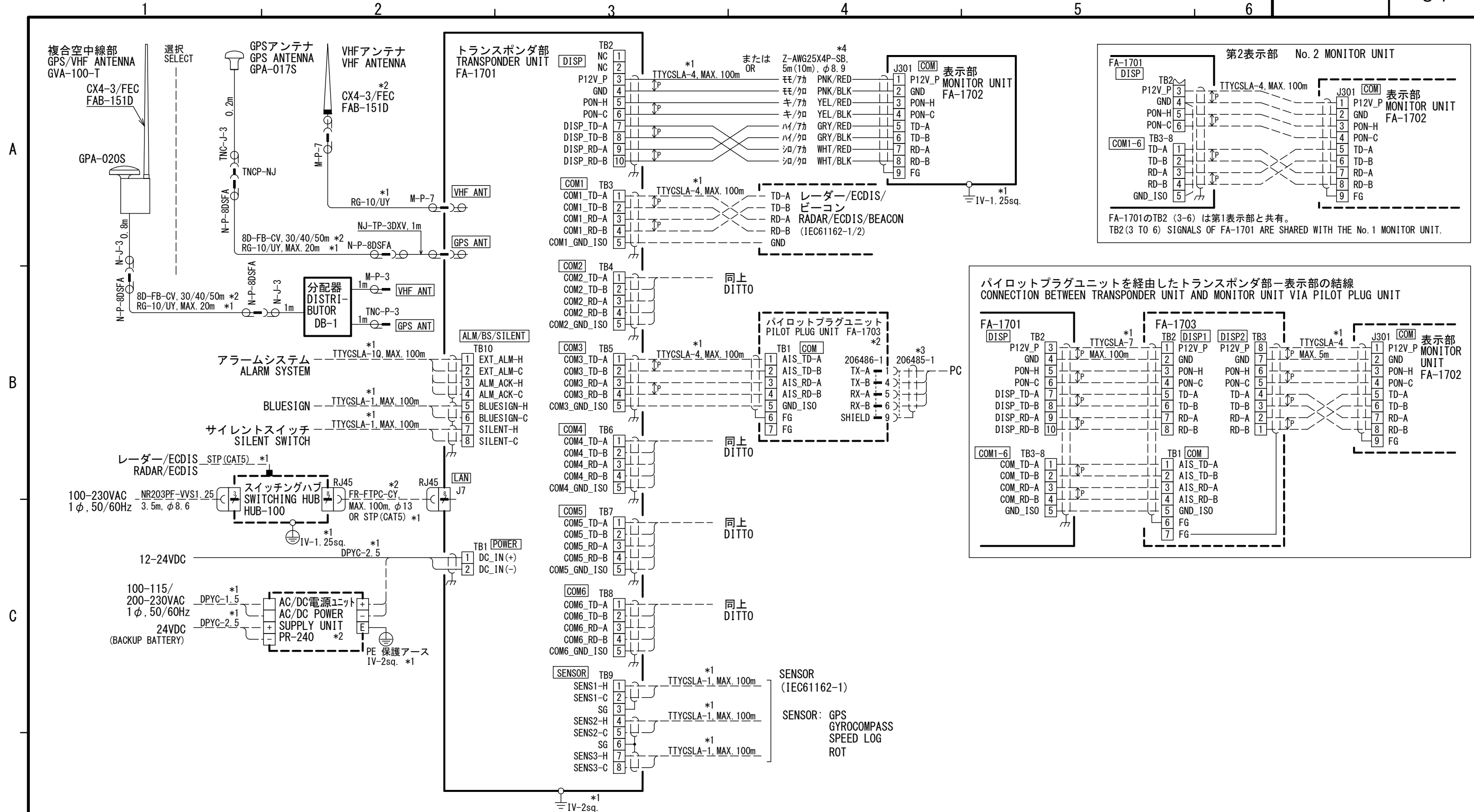

DRAWN	25/Feb/2019 T. YAMASAKI	TITLE	FA-170
CHECKED	25/Feb/2019 H. MAKI	名称	国際船舶自動識別装置
APPROVED	26/Feb/2019 H. MAKI		相互結線図
SCALE	MASS kg	NAME	U-AIS TRANSPONDER
DWG No.	C4490-C01- E	REF. No.	05-109-1001-0
			INTERCONNECTION DIAGRAM