

Installation Instructions

Vaisala K-PATENTS® SAFE-DRIVE™ Process Refractometer PR-23-SD Upgrade Kits



VAISALA

Contents

Section 1	Background information	3
Section 2	Identifying your SAFE-DRIVE system version	4
	2.1 Generation 1	4
	2.2 Generation 2	5
Section 3	Upgrading from Generation 1 to Generation 2.1	6
	3.1 Upgrade options.....	6
	3.1.1 SDR2-KIT for Isolation valve and Retractor	6
	3.1.2 SN2-KIT for Prism wash nozzle for steam.....	6
	3.1.3 WP2-KIT for Prism wash nozzle for high pressure water.....	7
	3.2 Before installation	8
	3.2.1 Components checklist.....	8
	3.3 Installation.....	10
	3.3.1 Safety requirements.....	10
	3.3.2 Locking bracket installation in Generation 1 Isolation valve.....	10
	3.3.3 Removal of Generation 1 Nozzle assembly	10
	3.3.4 Installation of Generation 2.1 Nozzle assembly	12
Section 4	Upgrading from Generation 2 to Generation 2.1	13
	4.1 SDR2-KIT-2.1 for documentation and parts	13
	4.2 Before installation	13
	4.2.1 Components checklist.....	13
	4.3 Installation.....	14
	4.3.1 Labels.....	14
	4.3.2 Safety pins and cable wires	15
	4.4 Upgrade report form	16

Installation Instructions for Vaisala K-Patents SAFE-DRIVE™ Process Refractometer PR-23-SD Upgrade Kits

1 Background information

We have upgraded the SAFE-DRIVE safety documentation. The new Generation 2.1 improvements in the safety instructions allow for better understanding of the most significant safety parameters, and emphasize different safety layers, check-points and parts that must be in place when operating the SAFE-DRIVE equipment.

The safety pin and safety clip are attached to the retractor handle with a cable wire. Furthermore, contrasting colors and marks are used to highlight the safety check points (see Figure 1). For instance, the safety bracket between the isolation valve and the retractor is painted in red to draw the user's attention. For safe insertion and retraction of the sensor, the user must lock the bracket with the safety pin or a padlock. Locking is possible only when the bayonets of the outer casing and isolation valve are aligned, and it secures that the casing is properly mounted.

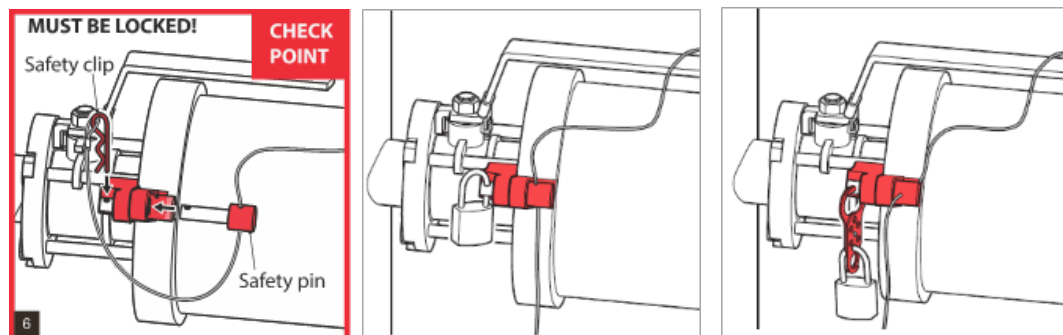

Figure 1 Examples of the upgraded safety documentation.

Vaisala strongly recommends all SAFE DRIVE Generation 1 and 2 users to update to the latest Generation 2.1 as a preventative measure to enhance the product safety. The **upgrade from Generation 1 to Generation 2.1** should be scheduled during the next upcoming shut-down. The **upgrade from Generation 2 to Generation 2.1** does not require a shut-down of the process line and can be implemented immediately.

2 Identifying your SAFE-DRIVE system version

2.1 Generation 1

Generation 1 System components are shown in Figure 2. In this system version the SDI isolation valve (No. 2) and the Retractor (No. 3) do not have locking brackets. Also the wash nozzle assembly (3a, b, c) is of original design.

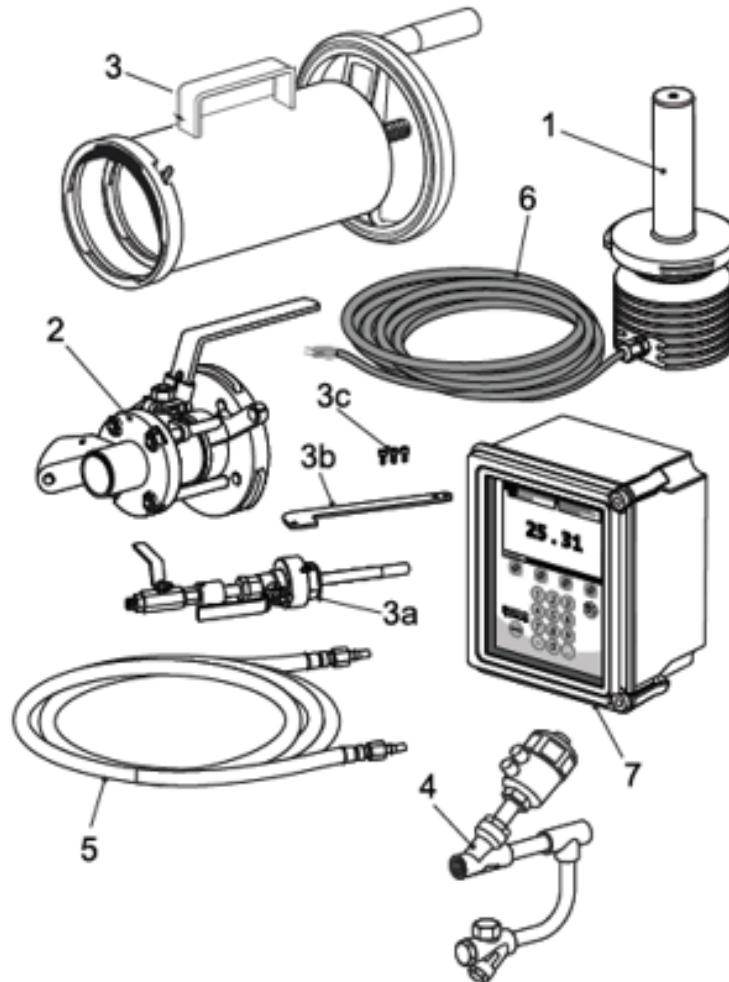

Figure 2 Generation 1 System components.

2.2 Generation 2

Generation 2 re-engineered components are shown in Figure 3. In this system version the other components remain intact, but the Isolation valve and Retractor (No. 1) have locking brackets (No. 2) and a safety pin (No. 3), but no locking pin. Generation 2 Retractors have a product label G2 on the handle indicating that the Retractor is of Generation 2. Also the wash nozzle assembly (4, 4a, b) has been re-designed and it has a safety pin (No. 3).

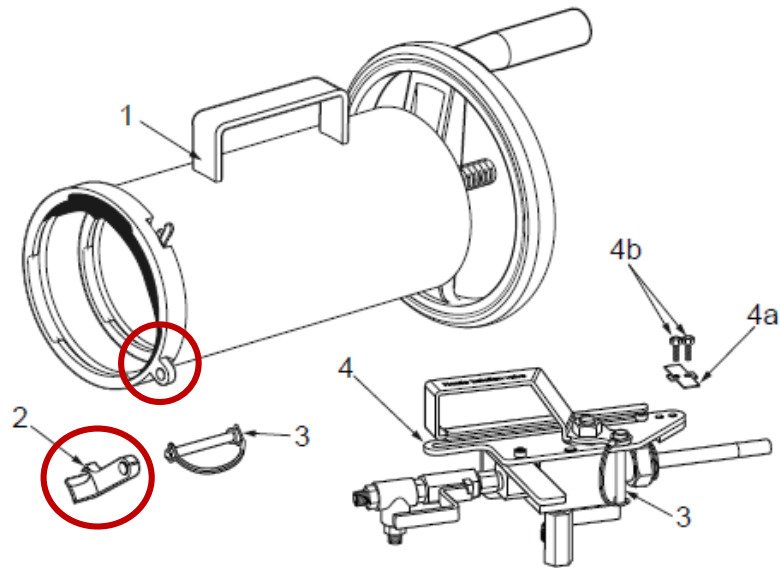

Figure 3 Generation 2 re-engineered system components.

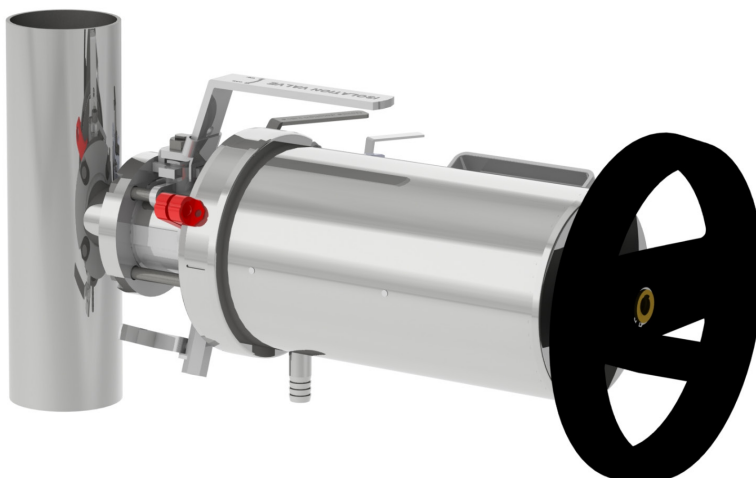

Figure 4 Generation 2 locking brackets (highlighted with red color) mounted on the Isolation valve and Retractor

3 Upgrading from Generation 1 to Generation 2.1

3.1 Upgrade options

3.1.1 SDR2-KIT for Isolation valve and Retractor

The SDR2-KIT consists of parts for upgrading the existing Isolation valve and replacing the Retractor and all SAFE-DRIVE safety documentation with new ones. The kit contains a new Retractor tool (complete kit consisting of the inner and outer casing), a PR-11026 locking bracket and new SAFE-DRIVE safety guides and instructions.

When multiple isolation valves are to be operated with the same Retractor tool, it is recommended to specify and order **one SDR2-KIT** and **additional Locking brackets PR-11026 for each upgraded isolation valve**.

It is recommended to dispose of the old Retractor Tool(s) and earlier versions of safety documentation to avoid their accidental use.

Model and Description	Part No.
SDR2-KIT = Retractor upgrade kit to SDR2-23, Gen 2.1	SDR2-KIT
Consisting of the following:	
SDR2-23 = SAFE-DRIVE Generation 2.1 RETRACTOR	SDR2-23
PR-11026 = Locking bracket for SDI isolation valve	PR-11026
Complete with Best Practices manual, Pocket guides, laminated insertion/retraction guides, upgrade installation instructions (this document)	
Additional locking brackets	
PR-11026 = Locking bracket for SDI isolation valve	PR-11026

3.1.2 SN2-KIT for Prism wash nozzle for steam

The SN2-KIT contains parts for upgrading steam wash nozzle with added safety features during the insertion and removal operation. The kit contains operational and safety guides.

Model and Description	Part No.
SN2-KIT = Steam wash upgrade kit to SN2	SN2-KIT
Consisting of the following:	
PR-11023-KIT = Steam kit for SN2 (Includes PR-11023 SDI2 steam wash nozzle SN2, PR-11030 Screws for SDI2 wash nozzle, PR-3516 Ball valve and PR-3304 Check valve)	PR-11023-KIT
PR-11025 = Nozzle isolation valve assembly for SDI2	PR-11025
Complete with safety pin and cable wire, Best Practice manual, Pocket guide, laminated insertion/retraction guide, upgrade installation instructions (this document)	

3.1.3 WP2-KIT for Prism wash nozzle for high pressure water

The WP2-KIT contains parts for upgrading high pressure wash nozzle with added safety features during the insertion and removal operation. The kit contains operational and safety guides.

Model and Description	Part No.
WP2-KIT = High pressure water wash upgrade kit to WP2	WP2-KIT
Consisting of the following:	
PR-11024-KIT = High pressure water kit for WP2 (Includes PR-11024 SDI2 High pressure water wash nozzle WP2, PR-11030 Screws for SDI2 wash nozzle, PR-3516 Ball valve and PR-3304 Check valve)	PR-11024-KIT
PR-11025 = Nozzle isolation valve assembly for SDI2	PR-11025
Complete with safety pin and cable wire, Best Practice manual, Pocket guide, laminated insertion/retraction guide, upgrade installation instructions (this document)	

3.2 Before installation

3.2.1 Components checklist

Before starting installation, make sure you have all the tools and components listed in Figure 5 and 6.

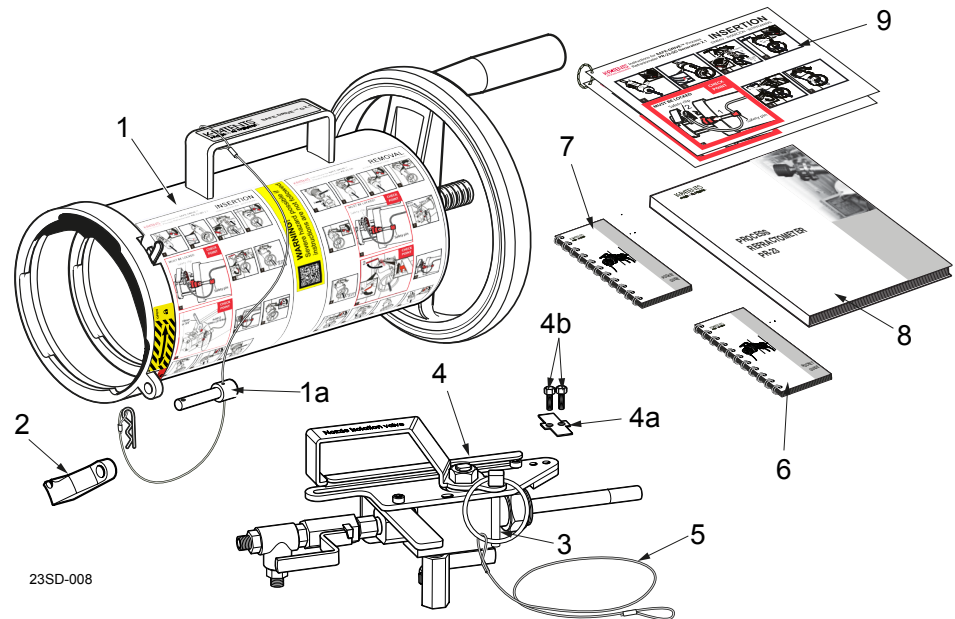
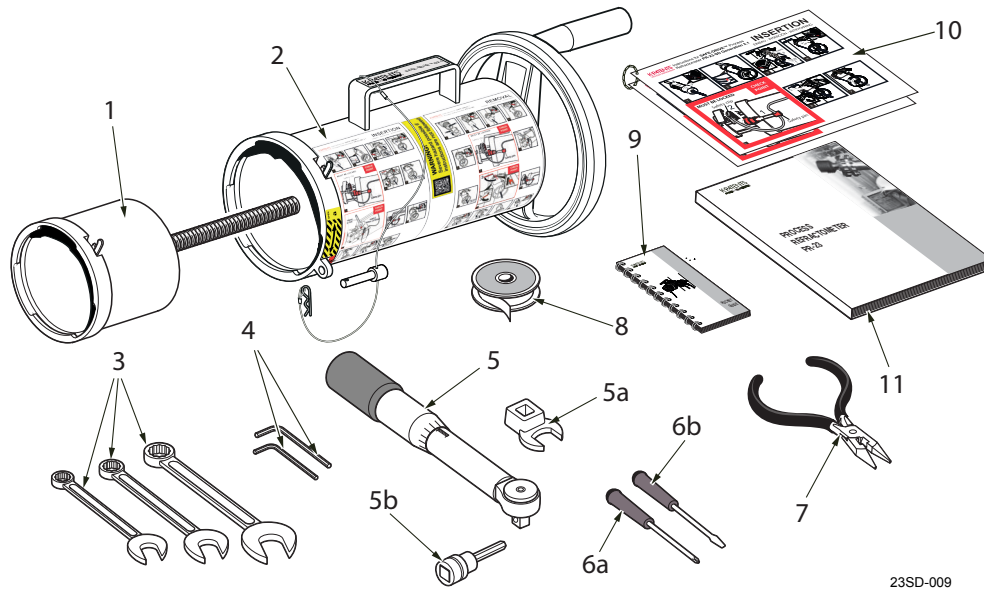

Figure 5 System components included in Vaisala delivery

- | | |
|-------------------------------|----------------------------------------------------------------------------------------------|
| <input type="checkbox"/> 1 | Retractor SDR2-23, Generation 2.1 |
| 1a | containing Safety pin, clip and cable wire connected on retractor handle |
| <input type="checkbox"/> 2 | Locking bracket PR-11026 |
| 3 - 5 | Orders with Wash nozzle assembly contain the following components: |
| <input type="checkbox"/> 4 | Wash nozzle assembly SN2-KIT or WP2-KIT |
| <input type="checkbox"/> 4a | containing nozzle locking plate |
| <input type="checkbox"/> 4b | 2 pcs of M5 bolt |
| <input type="checkbox"/> 3, 5 | Safety pin and cable wire for prism nozzle isolation valve connected on wash nozzle assembly |
| <input type="checkbox"/> 6 | SAFE-DRIVE pocket guide IM-EN-SDI21-PG |
| <input type="checkbox"/> 7 | SAFE-DRIVE pocket guide for installation IM-EN-SDI21INST-PG |
| <input type="checkbox"/> 8 | SAFE-DRIVE Process refractometer PR-23-SD Generation 2.1 Best Practices IM-EN-SDGEN21-BP |
| <input type="checkbox"/> 9 | Laminated instructions for removal and insertion of SAFE-DRIVE Process refractometer |

NOTE: If any of components are missing, contact your supplier before starting installation.



23SD-009

Figure 6 Installation equipment

<input type="checkbox"/> 1	Retractor inner casing	Supplied by Vaisala
<input type="checkbox"/> 2	Retractor outer casing	Supplied by Vaisala
<input type="checkbox"/> 3	Combination wrenches, 32 mm (1 pc), 14 mm (1 pc), 8 mm (1 pc)	
<input type="checkbox"/> 4	Allen keys 8 mm (1 pc), 5 mm (1 pc)	
<input type="checkbox"/> 5	Torque wrench	
<input type="checkbox"/> 5a	open end fitting 19 mm	
<input type="checkbox"/> 5b	hex bit socket 8 mm	
<input type="checkbox"/> 6	Screw driver	
<input type="checkbox"/> 6a	Phillips head	
<input type="checkbox"/> 6b	Flathead	
<input type="checkbox"/> 7	Pliers	
<input type="checkbox"/> 8	Thread seal tape	
<input type="checkbox"/> 9	Pocket guide for insertion and retraction of sensor and wash nozzle	Supplied by Vaisala
<input type="checkbox"/> 10	Laminated instructions for insertion and removal of SAFE-DRIVE sensor	Supplied by Vaisala
<input type="checkbox"/> 11	SAFE-DRIVE Process refractometer PR-23-SD Generation 2.1 Best Practices IM-EN-SDGEN21-BP	Supplied by Vaisala

3.3 Installation

3.3.1 Safety requirements

WARNING: The SAFE-DRIVE Isolation valve SDI can only be upgraded during a shutdown of the process line.

WARNING: Always shut down the main steam valve before performing any work on the wash nozzle. Ensure process pipe is empty and not pressurized.

For more safety requirements, please see the safety instructions included in the delivery.

3.3.2 Locking bracket installation in Generation 1 Isolation valve

1. Remove top left bolt
2. Insert safety locking bracket according to Figure 7
3. Tighten all four bolts to 36Nm (26lb ft).

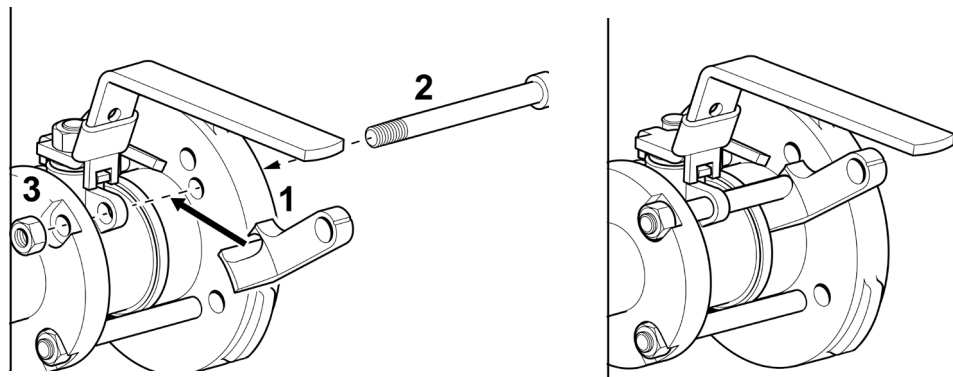

Figure 7 Locking bracket installed

3.3.3 Removal of Generation 1 Nozzle assembly

WARNING: Always shut the main steam valve before performing any work on the wash nozzle. Ensure process pipe is empty and not pressurized.

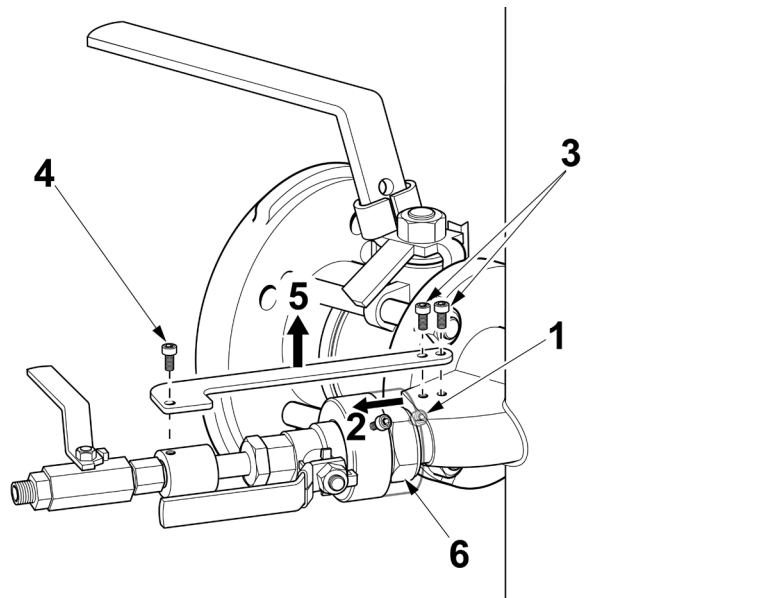

Figure 8 Removal of Gen 1 nozzle assembly

1. Close the steam connections
2. Detach the steam line
3. Open safety cover M5 Allen screw (1)
4. Detach the safety cover over the nozzle nut (2)
5. Remove three M5x8 screws (3, 4)
6. Remove nozzle guide plate (5)
7. Open the large nozzle nut (6)

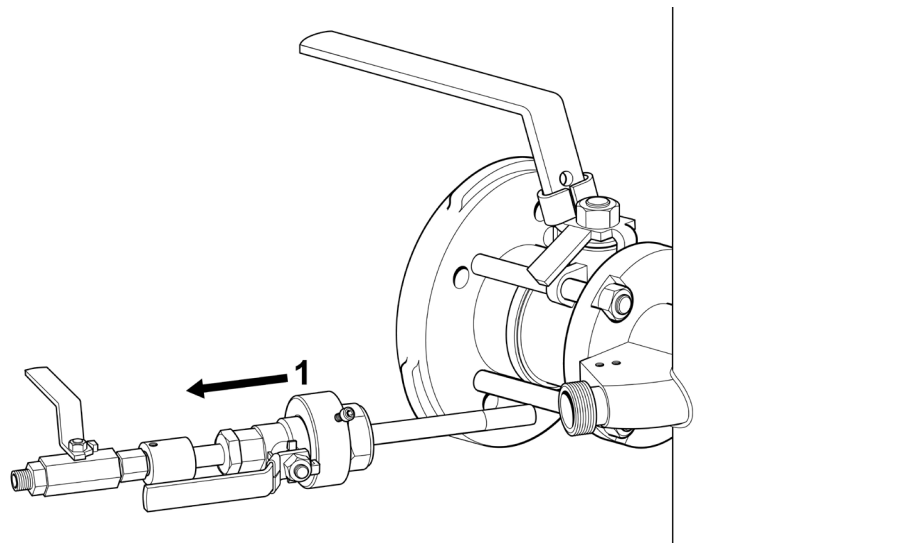

Figure 9 Removal of Gen 1 nozzle assembly

8. Remove nozzle assembly.

3.3.4 Installation of Generation 2.1 Nozzle assembly

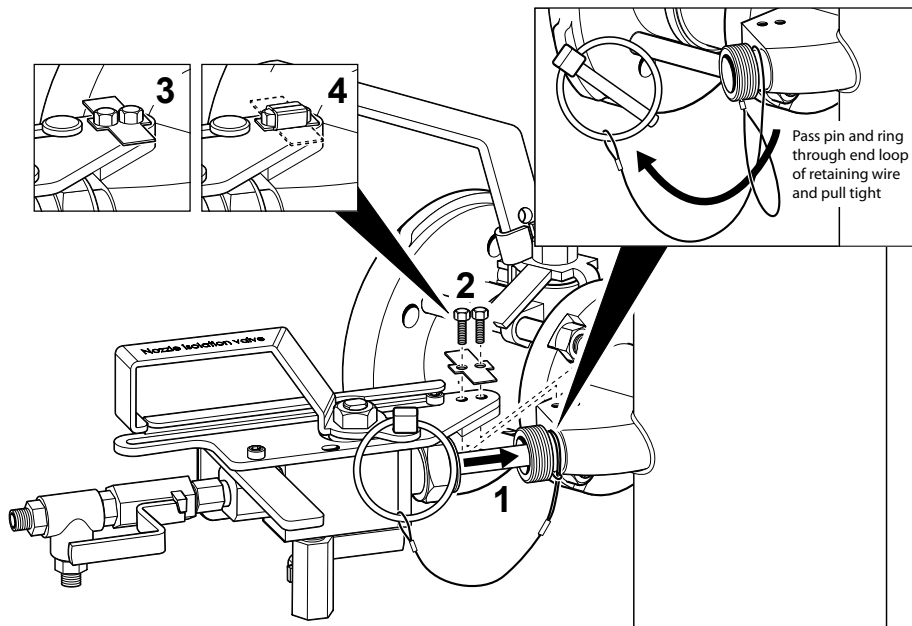

Figure 10 Installation of the Gen 2.1 wash nozzle

To re-install the wash nozzle assembly:

1. Insert the wash nozzle assembly to its place (1). Tighten up 32 mm nozzle nut with a combination wrench.
2. Place the nozzle guide plate in the correct position and tighten the two (2) M5 bolts (2)
3. Secure the wash nozzle bolts with a locking plate (3, 4).
4. Pass pin and ring through end loop of retaining wire and pull tight to connect the cable wire on nozzle isolation valve.
5. Lock the safety pin on the nozzle plate.

4 Upgrading from Generation 2 to Generation 2.1

4.1 SDR2-KIT-2.1 for documentation and parts

The SDR2-KIT-2.1 consists of parts for upgrading the existing Generation 2 Retractor and replacing all SAFE-DRIVE safety documentation with new ones.

When multiple Generation 2 wash nozzles are upgraded, it is recommended to specify and order **additional Safety pins and cable wires for prism nozzle isolation valve PR-11041 for each upgraded nozzle assembly.**

It is recommended to dispose of the earlier versions of the safety documentation to avoid their accidental use.

The **upgrade from Generation 2 to Generation 2.1** does not require a shut-down of the process line and can be implemented immediately.

4.2 Before installation

Before starting installation, make sure you have all the components listed in Figure 11.

4.2.1 Components checklist

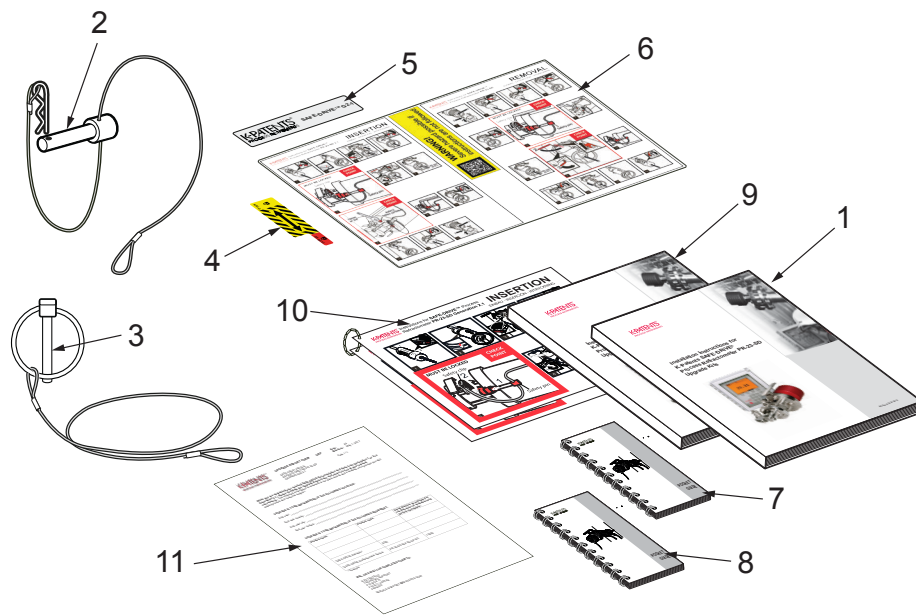

Figure 11 Upgrade documents and parts included in Vaisala delivery

- | | |
|-----------------------------|---------------------------------------------------------------------------------------------------------------------------------------|
| <input type="checkbox"/> 1 | Installation instructions for Vaisala K-Patents Safe-Drive Process refractometer PR-23-SD Upgrade kits IM-EN-SDI21UPG (this document) |
| <input type="checkbox"/> 2 | Safety pin, clip and cable wire for Retractor handle PR-11040 |
| <input type="checkbox"/> 3 | Safety pin, clip and cable wire for prism nozzle isolation valve PR-11041 |
| <input type="checkbox"/> 4 | Yellow locking bracket safety label for Retractor |
| <input type="checkbox"/> 5 | Product version information label for Retractor handle |
| <input type="checkbox"/> 6 | Removal/insertion instruction label for Retractor |
| <input type="checkbox"/> 7 | SAFE-DRIVE pocket guide IM-EN-SDI21-PG |
| <input type="checkbox"/> 8 | SAFE-DRIVE pocket guide for installation IM-EN-SDI21INST-PG |
| <input type="checkbox"/> 9 | SAFE-DRIVE Process refractometer PR-23-SD Generation 2.1 Best Practices IM-EN-SDGEN21-BP |
| <input type="checkbox"/> 10 | Laminated instructions for removal and insertion of SAFE-DRIVE Process refractometer |
| <input type="checkbox"/> 11 | Upgrade Report Form URF to be completed and returned to Vaisala |

4.3 Installation

4.3.1 Labels

First place the new labels on Retractor:

- Yellow locking bracket safety label is placed next to the locking bracket so that the red part is aligned with the bracket.
- Removal-insertion instructions label is placed next to the handle, the top part nearest to the handle.
- Product label indicating the SAFE-DRIVE Retractor code and Generation 2.1 is placed on the retractor handle. It replaces the former G2 label.

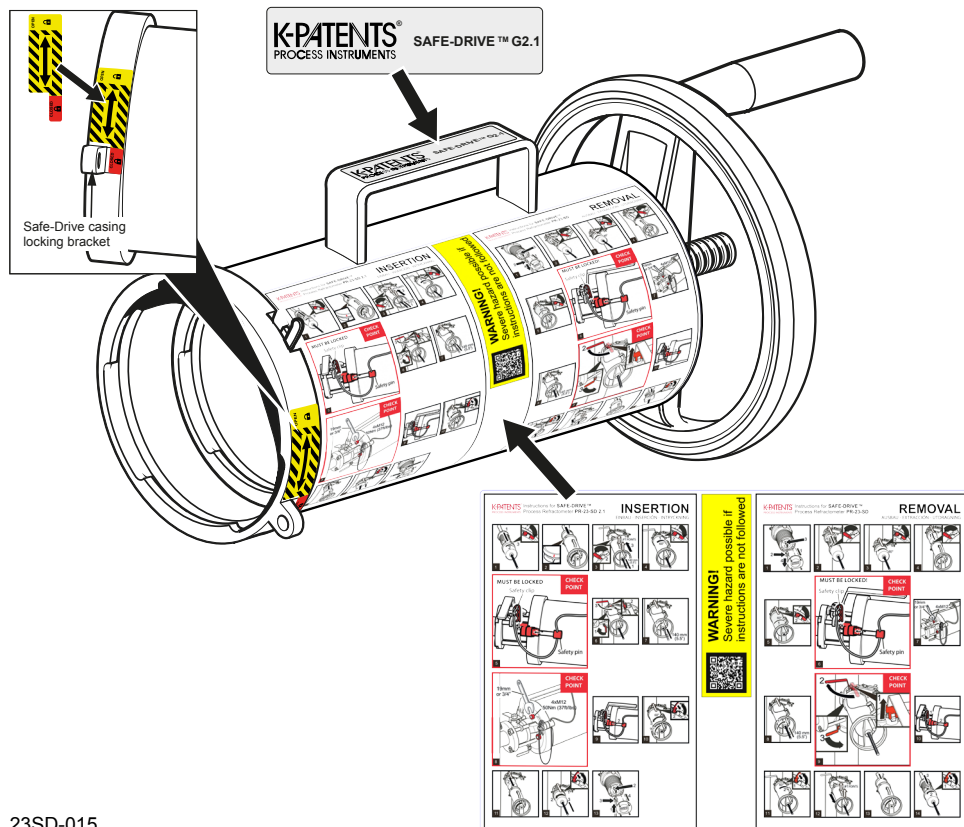

Figure 12 Placing the labels

4.3.2 Safety pins and cable wires

The locking pin assembly is looped over the Retractor handle. Pull the safety clip and safety pin through the loop on the end of the wire to secure the assembly to the Retractor.

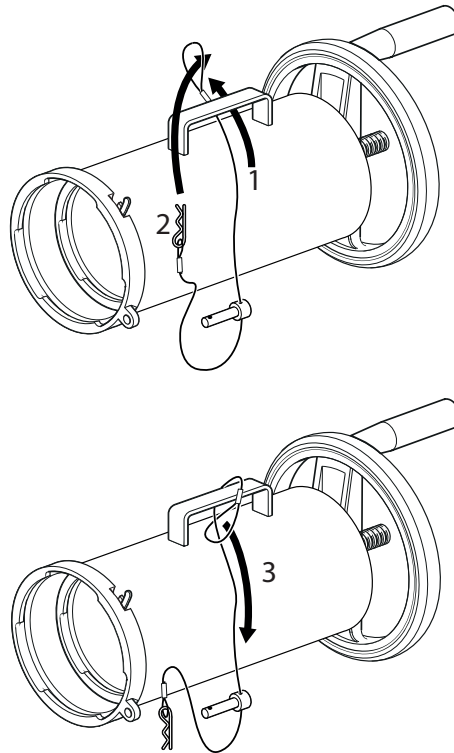

Figure 13 Attaching the cable wire with safety pin and clip

For installing the wash nozzle safety wire, see Figure 10.

4.4 Upgrade report form

You can find an Upgrade Report Form URF in the upgrade kit SDR2-KIT-2.1 delivery.

Once the equipment has been upgraded, please complete and return the Upgrade Report Form back to Vaisala via mail or e-mail to:

Vaisala Oyj
Liquid measurements technical support
P.O. Box 26
FI-00421 Helsinki
Finland

helpdesk@vaisala.com

The form is requested for keeping the installation data records up to date on SAFE-DRIVE generations in the field. Accurate data records are vital part of Vaisala technical and product support.

VAISALA

www.vaisala.com