



YARWAY BLOW-OFF VALVES

SEATLESS, HARDSEAT AND UNIT TANDEM

Designed for blow-off service in boiler systems with pressures of 3206 psig.



FEATURES

- Designed according ASME section 1, ASME B31.1, ASME B16.34.
- For boiler systems up to 3206 psig.
- Rugged construction to withstand high pressure and high velocities.
- Excellent resistance to cleaning acids and wear caused by precipitated solids.

Seatless valves

- No Seat
 - will not score or plug with dirt
 - will not leak
- Live-loaded packing
 - will not leak after packing
- Slow opening
 - will not rapidly drain boiler drum

Unit tandem valves

- Combination of hardseat and seatless valves in a single body
 - eliminates pipe joints
 - reduces potential leaks
 - fits into a confined space

Hardseat valves

- Stellite seat faces
 - resists wear
 - provides long service life

GENERAL APPLICATION

Blow-off service in boiler systems to remove dirt, sediment and scale as well as maintain boiler level surge.

TECHNICAL DATA

Size range: NPS 1, 1¼, 1½, 2, 2½
[DN 25, 32, 40, 50, 65]
Pressure Rating: Up to 3206 psi
Connection: Flanged, Socketweld, Buttweld
Materials: Cast Iron, Carbon Steel

YARWAY BLOW-OFF VALVES

SEATLESS, HARDSEAT AND UNIT TANDEM

GENERAL DESCRIPTION

Basic requirements for the design and use of blow-off valves are established by the ASME Power Boiler Code, Section I. The general form of a valve, the materials of its construction, allowable boiler pressures, and the installation of the valve are all determined by the code. Yarway blow-off valves are designed in conformance with all code requirements (ASME Section I, ASME B31.1, ASME B16.34).

Because the primary purpose of a blow-off valve is removal of dirt, sediment and scale, the boiler code requires that valves which have dams or pockets in which sediment can accumulate cannot be used in blow-off service. This means that ordinary globe valves cannot be used as blow-off valves.

Yarway valves are especially designed for the punishment of blow-off service in boiler systems with pressures of 3206 psi.

The rugged construction of these valves can successfully withstand the combination of problems inherent in the service - a service in which high pressures result in high velocities which can cause wire drawing and cavitation of metal surfaces.

The valves must also withstand the corrosive environment created by acid cleaning of boilers, and the potential wear problems caused by precipitated solids.

The valves are also helpful in maintaining boiler level surge within desirable limits during quick startup of high pressure systems.

Two broad categories of Yarway blow-off valves are available; those that operate on a sliding principle and those that operate on a seat-and-disc principle.

TYPE B SEATLESS BLOW-OFF VALVE

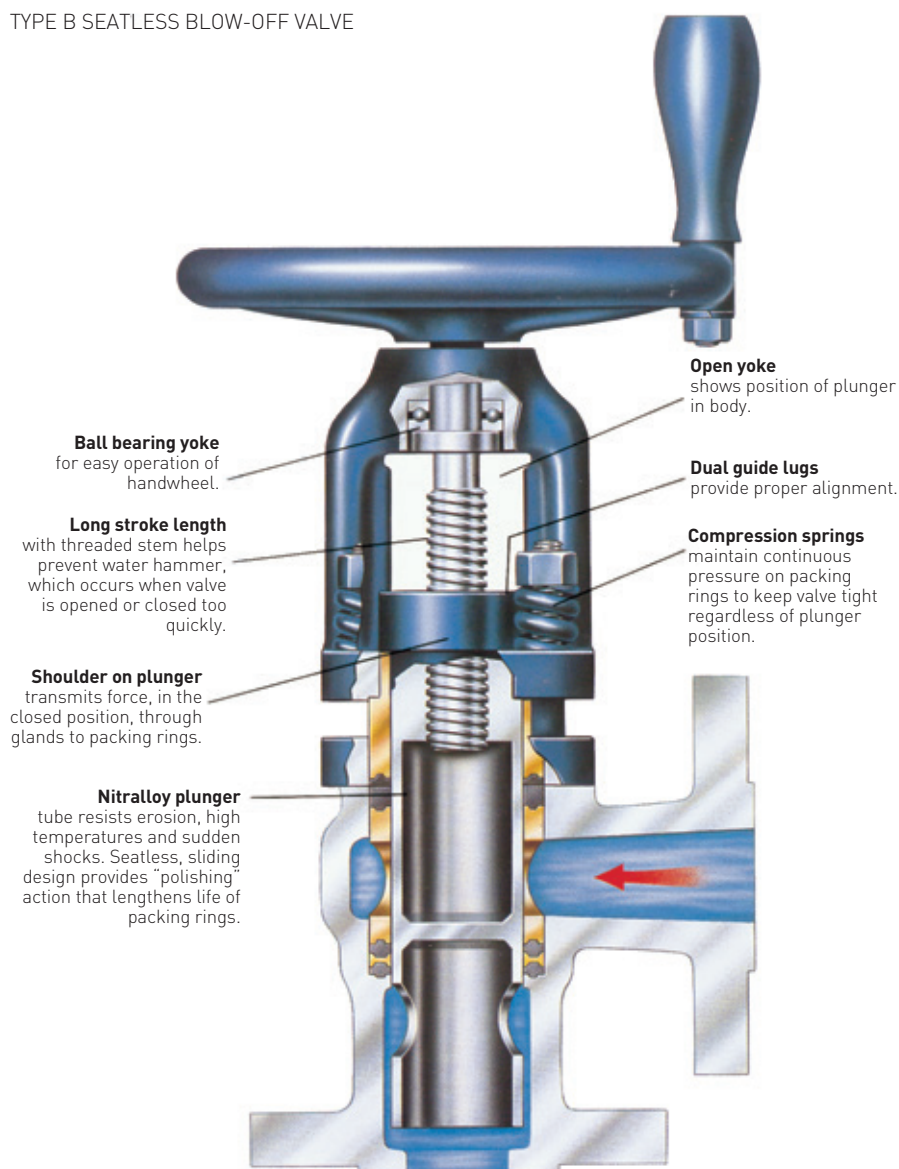

YARWAY BLOW-OFF VALVES

SEATLESS, HARDSEAT AND UNIT TANDEM

Flange and drilling data common to all Yarway valve designs are shown below. All dimensions are consistent with ASME standards and supplied as listed unless otherwise specified.

BLOW-OFF VALVE FLANGE DATA - FLANGE DIMENSIONS

Size NPS	Diameter			Thickness ¹				Diameter of raised face	
	Class 250-600	Class 1500	Class 2500	Class 250-300	Class 400-600	Class 1500	Class 2500	Class 250	Class 300-2500
1	4 ⁷ / ₈	5 ⁷ / ₈	6 ¹ / ₄	1 ¹¹ / ₁₆	1 ¹⁵ / ₁₆ [2]	1 ³ / ₈	1 ⁵ / ₈	2 ¹¹ / ₁₆	2
1 ¹ / ₂	6 ¹ / ₈	7	8	1 ¹³ / ₁₆	1 ¹ / ₈	1 ¹ / ₂	2	3 ⁹ / ₁₆	2 ⁷ / ₈
2	6 ¹ / ₂	8 ¹ / ₂	9 ¹ / ₄	7 ⁷ / ₈	1 ¹ / ₄	1 ³ / ₄	2 ¹ / ₄	4 ³ / ₁₆	3 ⁵ / ₈
2 ¹ / ₂	7 ¹ / ₂	9 ⁵ / ₈	10 ¹ / ₂	1	1 ³ / ₈	1 ⁷ / ₈	2 ¹ / ₂	4 ¹⁵ / ₁₆	4 ¹ / ₈

DRILLING DATA

Size (NPS)	No. of holes ^[3]	Diameter			Bolt circle diameter		
		Class 250-600	Class 1500	Class 2500	Class 250-600	Class 1500	Class 2500
1	4	3 ³ / ₄	1	1	3 ¹ / ₂	4	4 ¹ / ₄
1 ¹ / ₂	4	7 ⁷ / ₈	1 ¹ / ₈	1 ¹ / ₄	4 ¹ / ₂	4 ³ / ₈	5 ³ / ₄
2	8	3 ³ / ₄	1	1 ¹ / ₈	5	6 ¹ / ₂	6 ³ / ₄
2 ¹ / ₂	8	7 ⁷ / ₈	1 ¹ / ₈	1 ¹ / ₄	5 ⁷ / ₈	7 ¹ / ₂	7 ³ / ₄

NOTES:

1. Includes 1/16" raised face 250-400 psi valves, 1/4" raised face 600-2500 psi.
2. 600 psi only, no 1" 400 psi valve available.
3. Bolt holes straddle center lines.

YARWAY BLOW-OFF VALVES

SEATLESS, HARDSEAT AND UNIT TANDEM

SEATLESS VALVES FOR PRESSURES TO 935 PSI - CLASS 250 TO 600

The seatless blow-off valve is a sliding plunger type, opened and closed by means of a handwheel and non-rising stem, and sealed against leakage by packing rings above and below the ports.

This valve is provided with heavy coil compression springs under the yoke nuts. Designed to help prevent leaking when the valve is open, yoke nuts are screwed down evenly and tightly placing compression on the springs and the packing rings.

Ample flow area is provided in the hollow plunger; absence of projections or pockets prevents accumulation of scale and sediment that can impede flow and shorten the life of the valve. Annular space in the body permits pressure to surround the plunger, making the valve a fully balanced unit easy to operate at high pressures.

For complete protection of the packing, the valve has a long-stroke plunger so that the packing is never exposed to the mainstream flow. The gland and plunger have double inlet ports to balance flow pressures.

This valve is available in angle or straightway styles, cast iron or steel construction, and flanged ends.

Operation

When the valve is open (plunger raised), discharge occurs through double ports in the lower gland and plunger. The slotted plunger head slides on guides in the valve yoke, preventing rotation of the plunger.

A stop screw keeps the lower gland in alignment. The yoke permits visual indication of the position of the plunger within the valve body.

Upon closing, the shoulder on the plunger exerts a thrust force compressing the packing rings above and below the port in the body. A final hard turn of the handwheel gives additional compression of the packing around the plunger, ensuring drop tight shutoff.

End connections

Flange dimensions per ASME B 16.5

Actuation

Manual handwheel only.



YARWAY BLOW-OFF VALVES

SEATLESS, HARDSEAT AND UNIT TANDEM

Standard options

Acid wash trim:

1. Standard upper gland is replaced with nickel plated steel upper gland.
2. Standard lower gland is replaced with Ni-resist lower gland.
3. Standard plunger is replaced with nickel plated nitralloy plunger.

Stop screw with lubrication fitting.

Caution plate for tandem sets.

Special flanges only when dimensions are within standard flange maximum metal conditions.

How to specify

To specify seatless valves for nominal pressures to 600 psi, use figure number shown. Describe as long stroke, balanced sliding plunger type seatless valve.

How to order

Order by stating:

- a. Size
- b. Figure number
- c. Basic pressure rating
- d. Connections - flanged
- e. Angle or straightway style

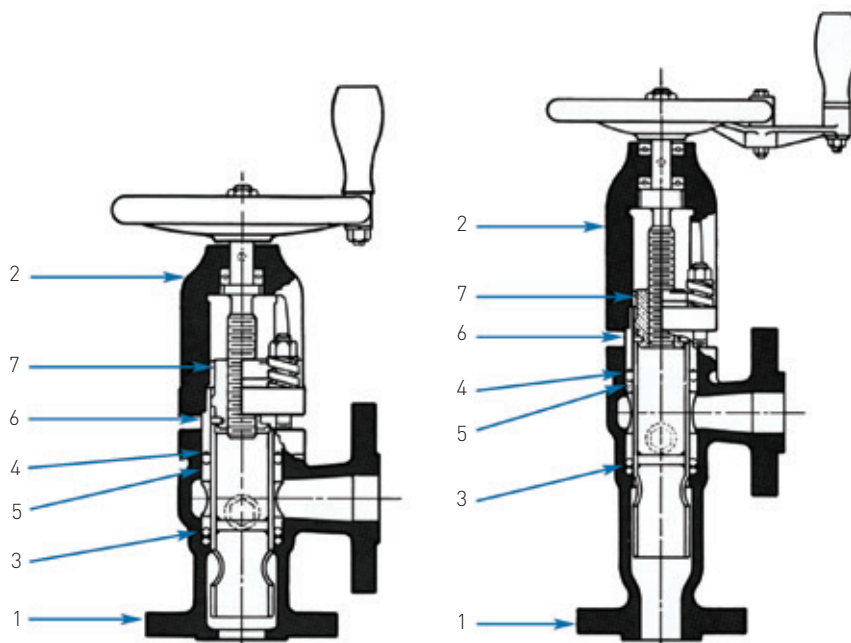

SEATLESS VALVES FOR PRESSURES TO 935 PSI - CLASS 250 TO 600

MATERIALS OF CONSTRUCTION (pressure containing envelope)

Valve type	Class	1 body	2 yoke	3 and 4 packing rings	5 and 6 glands	7 plunger
B	250	Cast iron ASTM A126 Class B	Cast iron ASTM A395 60-40-18	Graphite, SS filled PTFE, Brass or SS support ring ¹⁾	Hard brass B135 Alloy 3	Nitralloy Grade H
B	300	Cast steel ASME SA216 Grade WCB	Cast steel ASME SA216 Grade WCB	Graphite, SS filled PTFE, Brass or SS support ring ¹⁾	Hard brass B135 Alloy 3	Nitralloy Grade H
C	600	Cast steel ASME SA216 Grade WCB	Cast steel ASME SA216 Grade WCB	Graphite, SS filled PTFE, SS support ring	Low Carbon steel	Nitralloy Grade H

NOTE:

1. 316 SS for acid wash trim.

YARWAY BLOW-OFF VALVES

SEATLESS, HARDSEAT AND UNIT TANDEM

SEATLESS VALVES FOR PRESSURES TO 935 PSI - CLASS 250 TO 600

FIGURE 3482-R AND 3486-R
TYPE B

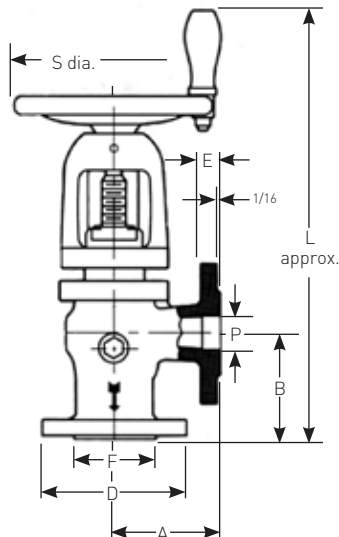

FIGURE 3484-R AND 3488-R
TYPE B

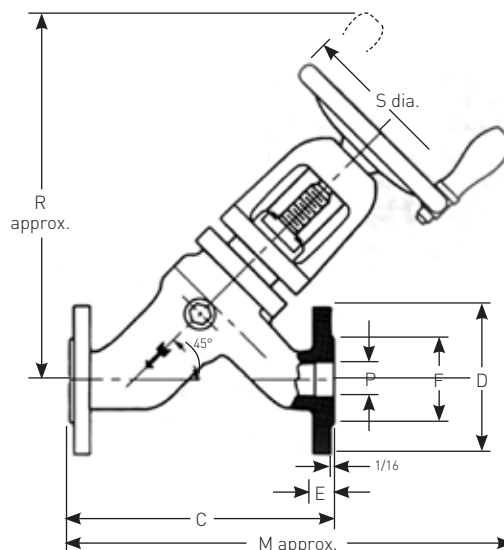

FIGURE 3910-R
TYPE C

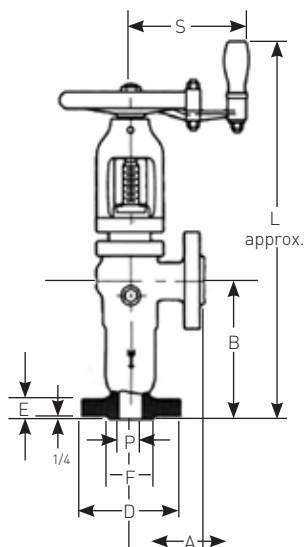
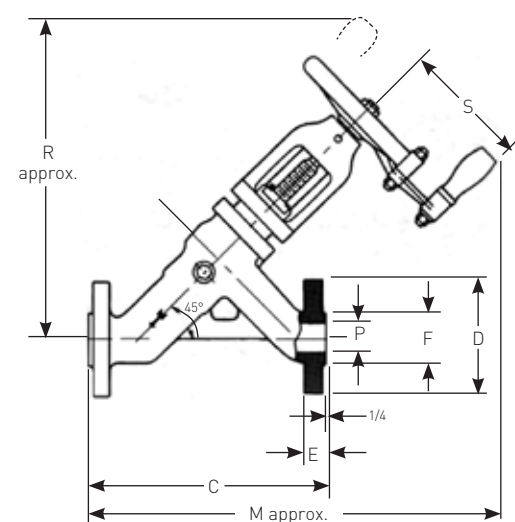

FIGURE 3912-R
TYPE C



DIMENSIONS AND WEIGHTS

Press. rating class	Blow-off (max. psi)	Figure number		Size NPS	Dimensions													Wt. (lb.)
		Angle	Straight-way		A	B	C	D	E	F	L	M	P	R	S	C _v		
250	200	3482-R	3484-R	1	4	6	10¼	4⅞	1⅛	2⅛	18¼	17¼	1	14 ¹³ / ₁₆	8⅞	24	30	
250	200	3482-R	3484-R	1½	4½	4½	11	6⅞	1⅜	3⅜	18¼	18½	1½	16	8⅞	30	38	
250	200	3482-R	3484-R	2	5	5	12	6½	⅞	4⅜	19⅞	19⅞	2	17	9⅞	58	55	
250	200	3482-R	3484-R	2½	5¾	5¾	13½	7½	1	4 ¹⁵ / ₁₆	21⅞	22⅞	2½	19½	11	73	85	
300	490	3486-R	3488-R	1	3 ¹⁵ / ₁₆	5⅞	9⅞	4⅞	1⅛	2	17¾	16⅞	1	14 ¹³ / ₁₆	8⅞	27	38	
300	490	3486-R	3488-R	1½	4 ⁷ / ₁₆	4 ⁷ / ₁₆	11	6⅞	1⅜	2⅞	18 ¹ / ₁₆	18½	1½	15⅞	8⅞	30	45	
300	490	3486-R	3488-R	2	5	5¼	12	6½	⅞	3⅞	19 ⁹ / ₁₆	19 ¹⁵ / ₁₆	2	17⅞	9⅞	58	65	
300	490	3486-R	3488-R	2½	5¾	6	13½	7½	1	4⅞	22⅞	22⅞	2½	19½	11	79	90	
600	935	3910-R	3912-R	1½	4½	8¼	13	6⅞	1⅞	2⅞	22⅞	22½	1½	19⅞	8⅞	30	53	
600	935	3910-R	3912-R	2	5¼	9¼	15	6½	1¼	3⅞	25¼	22 ⁵ / ₁₆	2	22 ⁵ / ₁₆	9⅞	59	75	
600	935	3910-R	3912-R	2½	5¾	9½	17	7½	1⅞	4⅞	27¾	28½	2½	25⅞	11	79	105	

YARWAY BLOW-OFF VALVES

SEATLESS, HARDSEAT AND UNIT TANDEM

HARDSEAT VALVES FOR PRESSURES TO 2455 PSI - CLASS 600 AND 1500

The hardseat valve has a seat and disc design with flow entering under the seat. It is opened and closed by means of a handwheel and threaded rising stem. The stuffing box bushing and threaded yoke bushing provide a simple, sturdy guide for the stem. This valve has been designed with thick Stellite facings on the disc and seat to provide the hard wearing, anti-galling surfaces characteristic of Stellite.

Operation

Hardseat valves are available in angle or straightway styles, socketweld or flanged end connections with manual or electric motor actuation. Usual installation of this valve allows the flow to enter below the seat. As the valve is opened, the lip on the end of the disc restricts the flow until the beveled edge or seating surface of the disc is well away from the seat. This minimizes wiredrawing and protects the sealing faces. The valve should be opened rapidly and fully to help increase the life of the internal parts.

Tandem usage

Any two Yarway hardseat valves may be used in tandem for pressures to 2455 psi. The valve nearest the boiler is used as the blowing valve (opened last and closed first) and the valve farthest from the boiler is the sealing valve (opened first and closed last). For pressures to 935 psi, hardseat valves may be used in tandem with Yarway Type C seatless valves.

How to specify

For single valves, describe as seat and disc type hardseat valve. Use size and figure number shown.

For tandem valves (pressures to 2455 psi), describe as: blow-off valves shall consist of one angle and one straightway (or two angle or two straightway) seat and disc type hardseat valves, installed in tandem arrangement, to conform with requirements of ASME Boiler Code and suitable for basic pressure rating of _____ psi.

How to order

Order by stating:

- a. Size
- b. Figure number
- c. Basic pressure rating
- d. Connections - flanged and socketweld for 600 class valves; socketweld for 1500 class valves.
As an option, buttweld ends are available for 2" and 2½" 1500 class valves only.
- e. Angle or straightway style



YARWAY BLOW-OFF VALVES

SEATLESS, HARDSEAT AND UNIT TANDEM

HARDSEAT VALVES FOR PRESSURES TO 2455 PSI - CLASS 600 AND 1500

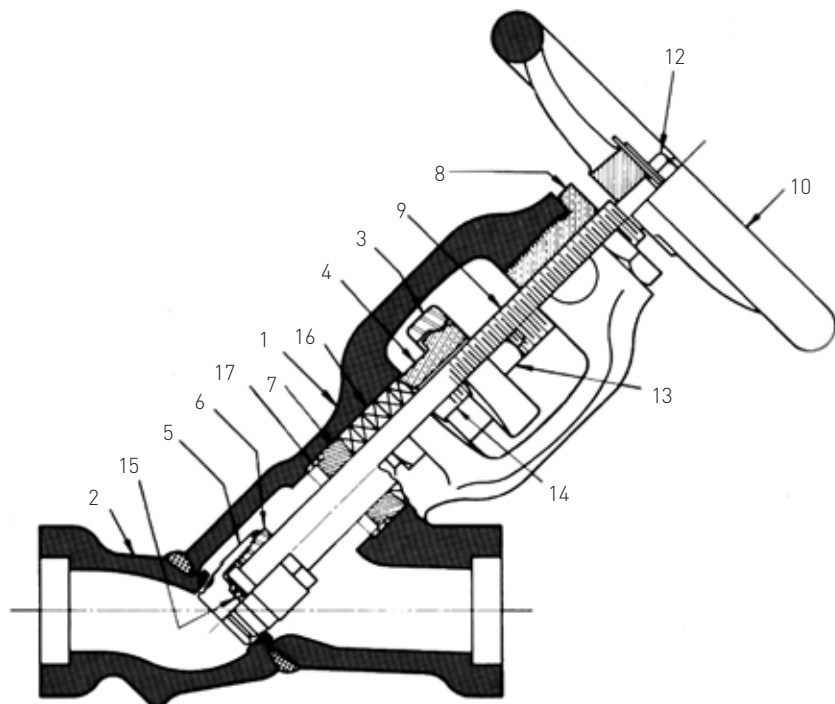

MATERIALS OF CONSTRUCTION

Item	Part	Figures 6909, 6911, 6912, 6929-C, 6931-C		Figures 6929, 6931	
		Material	Specifications	Material	Specifications
1	Body	Steel	ASME SA-216 WCB	Steel	ASME SA-105 ¹
2	Nozzle with integral seat	Steel with integral stellited face	ASME SA-216 WCB	Steel with integral stellited face	ASME SA-105 ¹
3	Gland	Steel	ASME SA-216 WCB ²	Steel	ASME SA-105 ¹
4	Split gland bushing	Naval brass ²	-	Stainless steel	AISI 416
5	Disc	Steel with stellited seating face	ASME SA-182 Grade F11	Steel with stellited seating face	ASME SA-182 Grade F11
6	Disc nut	Stainless steel	AISI 410 ²	Stainless steel	AISI 410 ²
7	Stuffing box bushing	Nickel alloy	Ni-Resist No. 1	Nickel alloy	Ni-Resist No. 1
8	Yoke bushing	Naval brass	-	Silicon brass	B-371 Alloy 694
9	Stem	Stainless steel	ASTM A-582 Type 416	Stainless steel	ASTM A-582 Type 416
10	Handwheel	Cast iron	ASTM A-47 Gr. 32510	Cast iron	ASTM A-47 Gr. 32510
12	Hex nut	Steel	ASME SA-194 Gr. 2H	Steel	ASME SA-194 Gr. 2H
13	Hex nut	Steel	ASME SA-194 Gr. 2H	Steel	ASME SA-194 Gr. 2H
14	Bolt	Steel	ASME SA-193 Gr. B7	Steel	ASME SA-193 Gr. B7
15	Disc insert	Stainless steel (heat treated)	AISI 410	Stainless steel (heat treated)	AISI 410
16	Packing	Flexible graphite	-	Flexible graphite	-
17	Sleeve insert ³	Steel	-	Steel	-

NOTES:

- 1 1/2" 6929 and 6931 only. 2" and 2 1/2" 6929-C and 6931-C body and nozzle are cast ASME SA216 WCB ("C" in Figure Number designates cast material); gland ASME SA217 WCB.
- 1 1/2" valve gland material is ASME SA181 Gr. II; split gland bushing and disc nut material is AISI 416.
- 2" and 2 1/2" valve only.

YARWAY BLOW-OFF VALVES

SEATLESS, HARDSEAT AND UNIT TANDEM

HARDSEAT VALVES FOR PRESSURES TO 2455 PSI - CLASS 600 AND 1500

FIGURE 6909-C

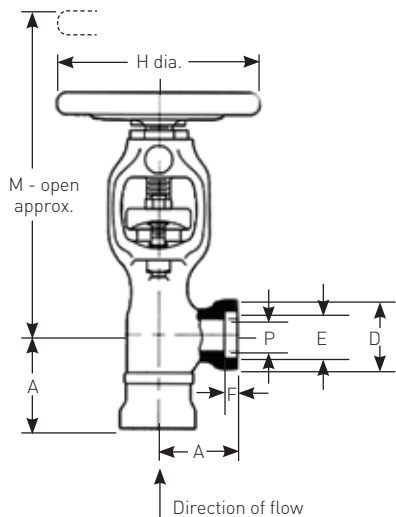

FIGURE 6910-C

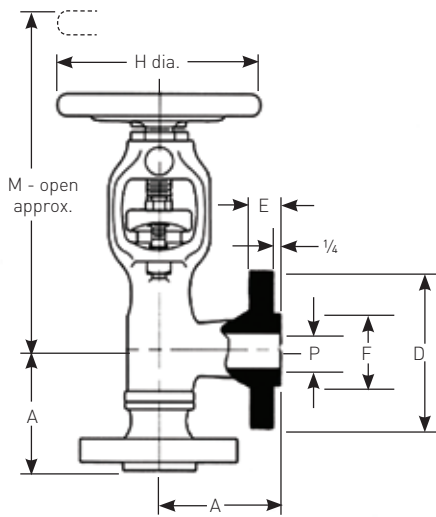

FIGURE 6911-C

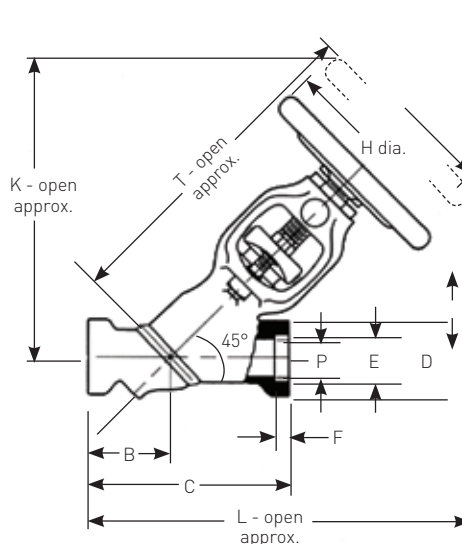

FIGURE 6912-C

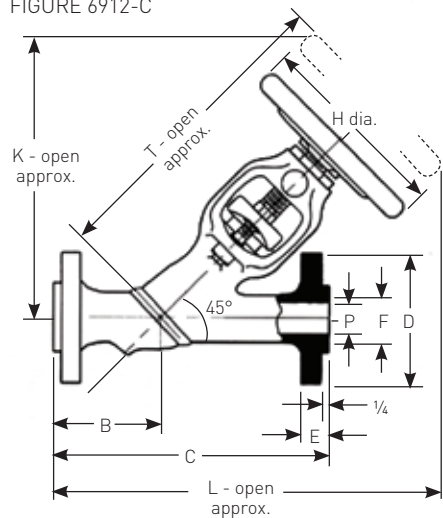

FIGURE 6929 AND 6929-C

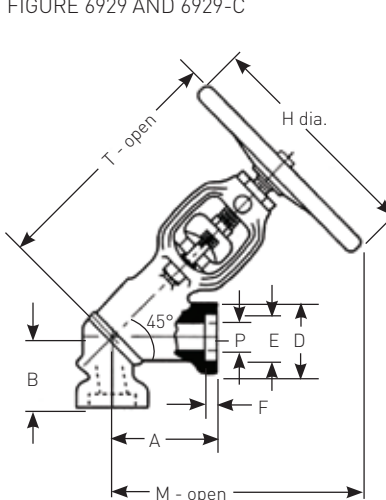
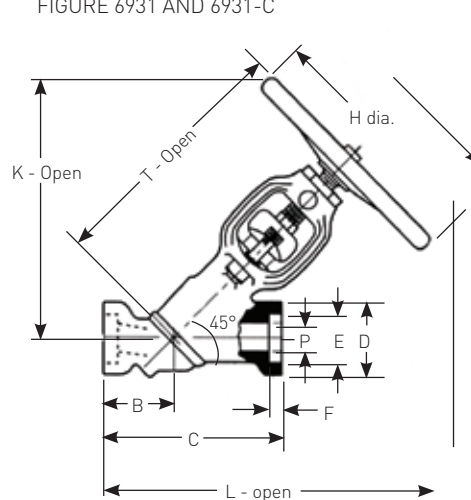

FIGURE 6931 AND 6931-C



DIMENSIONS AND WEIGHTS

Press. class rating	Blow-off (max. psi)	Figure number		Size NPS	Dimensions													Wt. (lb.)
		Angle	Straight-way		A	B	C	D	E	F	H	K	L	M	P	T	C _v	
600	935	6909-C	6911-C	1½	3¼	3¾	8¼	3	1.92	½	11½	12¾	16½	11¼	1½	12¾	41	25
600	935	6909-C	6911-C	2	3¾	3¾	9	3½	2.41	⅝	11½	14¾	18¾	13¾	2	15	96	44
600	935	6909-C	6911-C	2½	4	4¾	10½	4	2.91	⅝	11½	16¾	20½	15½	2½	17¾	125	75
600	935	6910-C	6912-C	1½	4¾	4½	12	6½	1½	27/8	11½	12¾	17¼	11¼	1½	12¾	41	36
600	935	6910-C	6912-C	2	5¾	5	14	6½	1¼	3¾	11½	14¾	19¾	13¾	2	15	96	55
600	935	6910-C	6912-C	2½	6½	5¾	16	7½	1¾	4½	11½	16¾	21¾	15½	2½	17¾	125	85
1500	2455	6929	6931	1½	5⅞	37/16	9	2¾	1.92	½	11½	16	19½	16	1¾	17	41	33
1500	2455	6929-C	6931-C	2	5¾	3¾	9¼	4½	2.41	⅝	13½	17¼	217/16	17¼	1½	18½	95	60
1500	2455	6929-C	6931-C	2½	5¾	3¾	9¼	4½	2.91	⅝	13½	17¼	217/16	17¼	2½	18½	95	60

YARWAY BLOW-OFF VALVES

SEATLESS, HARDSEAT AND UNIT TANDEM

UNIT TANDEM VALVES FOR PRESSURES TO 3206 PSI - CLASS 300 TO 2500

The Yarway unit tandem valve features a one-piece steel block which serves as a common body for both blowing and sealing valves. This construction eliminates interconnecting welds, or bolts and gaskets where flanged valves are required, and makes the unit tandem a compact design.

For valves with basic pressure rating to 600 psi (medium pressure unit tandem), the inlet valve is a hardseat type and the discharge valve is of the seatless type. For basic pressure ratings above 600 to 2500 psi, both inlet and discharge valves are hardseat type.

All features of the Yarway single valves are contained in the unit tandem design with the additional advantage of a one-piece, heavy duty construction.

These valves are available in right-hand or left-hand body assemblies, carbon steel (ASME SA-105), socketweld or flanged end connections. All hardseat unit tandem valves include acid wash trim.

In hardseat seatless unit tandem valves, acid wash trim is optional.

The hardseat valve of any unit tandem can be equipped with an electric motor actuator (230/460-volt, three-phase, 60-Hertz).

Special voltage and standard actuator accessories are available.

How to specify

To specify unit tandem valves use size and figure numbers shown. Describe as: valve assembly shall consist of one seat and disc type hardseat valve and one balanced, sliding plunger type seatless valve (or two seat and disc hardseat valves) assembled in tandem arrangement as part of one common body conforming with requirements of ASME Boiler Code and suitable for pressure rating of _____ psi.

When motor actuation is desired, describe as: ...with electric motor actuation (230/460-volt, three-phase, 60-Hertz).

How to order

Order by stating:

- Size
- Figure number
- Basic pressure rating
- Connectors - flanged or socketwelding ends
(if buttwelding ends are required, include description of profile)
- Hand: right-hand or left-hand
- Trim: standard or acid wash

How to "hand" unit tandem valves

Because the construction and installation of a unit tandem valve is inherently "off-center" with respect to the centerline of the boiler outlet, opening and closing of the valve can become difficult if operating space is inadequate on the side of the blowing valve.

Therefore, the practice of "handing" a valve has become part of its specification. This is essentially a statement of planned position for the valve, to the left-hand or right-hand of the centerline of the boiler outlet, by specifying the location of the sealing valve when facing the handwheel of the blowing valve (next to boiler). The drawing shown should help you to "hand" or orient your valves correctly.

Specify location (right or left) of sealing valve when facing handwheel of next-to boiler hardseat blowing valve.

1½" 6978-6978 LEFT HAND

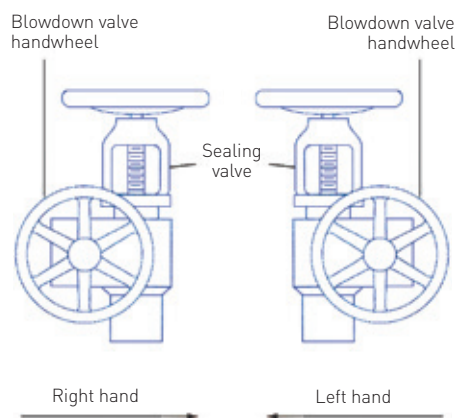
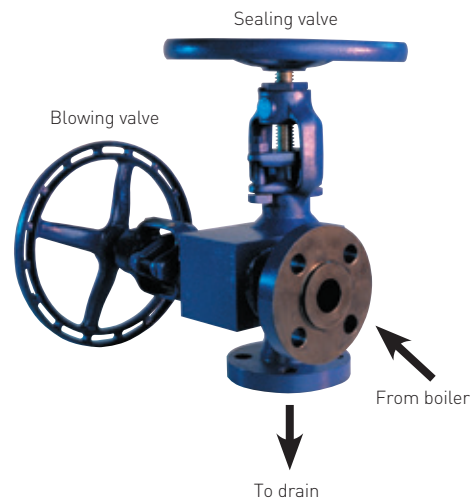

YARWAY BLOW-OFF VALVES

SEATLESS, HARDSEAT AND UNIT TANDEM

MATERIALS OF CONSTRUCTION (see pages 8 - 11 for drawing references)

Item	Part	Material	Specification
1	Body	Carbon steel - 0.35% max. C (Stellited seat)	ASME SA-105
13	Spring	Steel	SAE 6150
14	Stud	Steel	ASME SA 193 Gr. B7
15	Extension lever	Malleable iron	-
16	Nozzle	Forged steel - 0.35% max. C	ASME SA-105
17	Yoke	Steel	ASME SA-105 ¹
19	Gland	Steel	ASTM A-181 Grade II ¹¹
20	Disc	Steel (stellited)	ASME SA-182 Grade F11
21	Split gland bushing	Stainless steel	Type 416 ²
22	Disc nut	Stainless steel	Type 410
23	Stuffing box bushing	Nickel alloy	Ni-Resist No. 1
24	Yoke bushing	Bronze	ASTM B-371 Alloy 694 ²
25	Stem	Stainless steel	ASTM A-582 Type 416
26	Bolt	Stainless steel	ASTM A-193-B6 ³
27	Handwheel	Cast iron	ASTM A-48
28	Packing	Flexible graphite (carbon braid end rings)	-
31	Disc insert	Stainless steel (heat treated)	AISI 410

NOTES:

1. 600 psi and lower rated valve; ASME SA-216 Gr. WCB.
2. 600 psi and lower rated valve; Naval Brass.
3. 600 psi and lower rated valve; ASME SA-193 B7.

DIMENSIONS AND WEIGHTS (see pages 8 - 11 for drawing references)

Press. rating class	Blow-off (max. psi)	Figure no.	Size NPS	Dimensions											Stem rise	C _v	Wt. (lb.)
				A	B	C	D	E	G	H	K (closed)	L (closed)	M	P			
300	490	3947-3927 ¹¹	1	5 ¹³ / ₁₆	5 ¹ / ₂	3	2 ³ / ₈	1.33	8 ³ / ₈	1/2	10 ⁵ / ₈	16 ⁷ / ₁₆	8 ³ / ₈	3 ¹ / ₃₂	15 ¹ / ₁₆	17	50
300	490	3947-3927 ¹¹	1 1/2	5 ¹³ / ₁₆	5 ¹ / ₂	3	3 ¹ / ₈	1.92	8 ³ / ₈	1/2	10 ⁵ / ₈	16 ⁷ / ₁₆	8 ³ / ₈	1 1/2	15 ¹ / ₁₆	22	65
300	490	3947-3927 ¹¹	2	6 ³ / ₁₆	5 ¹⁵ / ₁₆	3 ¹³ / ₁₆	3 ³ / ₈	2.41	9 ³ / ₈	5/8	12 ⁵ / ₁₆	18 ¹ / ₂	9 ³ / ₈	1 ¹⁵ / ₁₆	1 ³ / ₁₆	38	108
300	490	3947-3927 ¹¹	2 1/2	7 ¹ / ₁₆	7 ¹ / ₁₆	4 ¹ / ₈	4	2.91	11	5/8	14 ¹¹ / ₁₆	21 ³ / ₄	11	2 1/2	1 1/4	47	150
300	490	3948-3928 ¹¹	1	4 ³ / ₄	7 ¹ / ₈	3	4 ⁷ / ₈	1 ¹¹ / ₁₆	8 ³ / ₈	-	10 ⁵ / ₈	15 ³ / ₈	8 ³ / ₈	1	15 ¹ / ₁₆	17	55
300	490	3948-3928 ¹¹	1 1/2	5 1/2	5 ³ / ₁₆	3	6 1/8	1 ¹³ / ₁₆	8 ³ / ₈	-	10 ⁵ / ₈	16 1/8	8 ³ / ₈	1 1/2	15 ¹ / ₁₆	25	70
300	490	3948-3928 ¹¹	2	5 ¹³ / ₁₆	5 ⁷ / ₁₆	3 ¹³ / ₁₆	6 1/2	7/8	9 ³ / ₈	-	12 ⁵ / ₁₆	18 1/8	9 ³ / ₈	2	1 ³ / ₁₆	39	113
300	490	3948-3928 ¹¹	2 1/2	6 ¹¹ / ₁₆	6 ¹¹ / ₁₆	4 ¹ / ₈	7 1/2	1	11	-	14 ¹¹ / ₁₆	21 ³ / ₈	11	2 1/2	1 1/4	47	163
600	935	6977-6953 ¹¹	1	4 ⁷ / ₈	5 1/2	2 ² / ₁₆	2	1.33	8 ³ / ₄	1/2	9 ³ / ₈	14 1/4	6	1	15 ¹ / ₁₆	9	50
600	935	6977-6953 ¹¹	1 1/2	5 ¹³ / ₁₆	7 1/8	3	3	1.92	7 1/4	1/2	10 ⁵ / ₈	16 ⁷ / ₁₆	11 1/2	1 1/2	15 ¹ / ₁₆	17	82
600	935	6977-6953 ¹¹	2	6 ³ / ₁₆	8 ⁷ / ₈	3 ¹³ / ₁₆	3 ³ / ₈	2.41	8 1/2	5/8	12 ⁵ / ₁₆	18 1/2	11 1/2	2	1 ³ / ₁₆	39	125
600	935	6977-6953 ¹¹	2 1/2	7 ¹ / ₁₆	10 ⁷ / ₈	4 ¹ / ₈	4	2.91	9 ⁵ / ₁₆	5/8	14 ¹¹ / ₁₆	21 ³ / ₄	11 1/2	2 1/2	1 1/4	75	174
600	935	6978-6954 ¹¹	1	4 ⁷ / ₈	5 1/2	2 ² / ₁₆	4 ⁷ / ₈	1 ¹¹ / ₁₆	8 ³ / ₄	-	9 ³ / ₈	14 1/4	6	1	15 ¹ / ₁₆	9	50
600	935	6978-6954 ¹¹	1 1/2	5 ¹³ / ₁₆	7 1/8	3	6 1/8	1 ¹³ / ₁₆	7 1/4	-	10 ⁵ / ₈	16 ⁷ / ₁₆	11 1/2	1 1/2	15 ¹ / ₁₆	17	82
600	935	6978-6954 ¹¹	2	6 ³ / ₁₆	8 ⁷ / ₈	3 ¹³ / ₁₆	6 1/2	7/8	8 1/2	-	12 ⁵ / ₁₆	18 1/2	11 1/2	2	1 ³ / ₁₆	39	125
600	935	6978-6954 ¹¹	2 1/2	7 ¹ / ₁₆	10 ⁷ / ₈	4 ¹ / ₈	7 1/2	1	9 ⁵ / ₁₆	-	14 ¹¹ / ₁₆	21 ³ / ₄	11 1/2	2 1/2	1 1/4	75	174
600	935	6977-6977 ²¹	1	4 ⁷ / ₈	5 1/2	2 ² / ₁₆	2	1.33	-	1/2	9 ³ / ₈	14 1/4	6	1	15 ¹ / ₁₆	9	50
600	935	6977-6977 ²¹	1 1/2	5 ¹³ / ₁₆	7 1/8	3	3	1.92	-	1/2	10 ⁵ / ₈	16 ⁷ / ₁₆	11 1/2	1 1/2	15 ¹ / ₁₆	29	82
600	935	6977-6977 ²¹	2	6 ³ / ₁₆	8 ⁷ / ₈	3 ¹³ / ₁₆	3 ³ / ₈	2.41	-	5/8	12 ⁵ / ₁₆	18 1/2	11 1/2	2	1 ³ / ₁₆	41	125
600	935	6977-6977 ²¹	2 1/2	7 ¹ / ₁₆	10 ⁷ / ₈	4 ¹ / ₈	4	2.91	-	5/8	14 ¹¹ / ₁₆	21 ³ / ₄	11 1/2	2 1/2	1 1/4	48	174
600	935	6978-6978 ²¹	1	4 ⁷ / ₈	-	2 ² / ₁₆	4 ⁷ / ₈	1 ¹¹ / ₁₆	-	-	9 ³ / ₈	14 1/4	6	1	15 ¹ / ₁₆	9	75
600	935	6978-6978 ²¹	1 1/2	5 ¹³ / ₁₆	-	3	6 1/8	1 ¹³ / ₁₆	-	-	10 ⁵ / ₈	16 ⁷ / ₁₆	11 1/2	1 1/2	15 ¹ / ₁₆	29	112
600	935	6978-6978 ²¹	2	6 ³ / ₁₆	-	3 ¹³ / ₁₆	6 1/2	7/8	-	-	12 ⁵ / ₁₆	18 1/2	11 1/2	2	1 ³ / ₁₆	41	230
600	935	6978-6978 ²¹	2 1/2	7 ¹ / ₁₆	-	4 ¹ / ₈	7 1/2	1	-	-	14 ¹¹ / ₁₆	21 ³ / ₄	11 1/2	2 1/2	1 1/4	48	240
1500	2455	6982-6982 ²¹	1	5 ⁵ / ₁₆	-	1 ⁵ / ₈	5 ⁷ / ₈	1 ³ / ₈	-	-	13 ³ / ₈	18 ¹⁵ / ₁₆	6	7/8	1	9	80
1500	2455	6982-6982 ²¹	1 1/2	5 ⁷ / ₈	-	2	7	1 1/2	-	-	16 1/2	22 ³ / ₈	11	1 ³ / ₈	1 1/16	25	130
1500	2455	6982-6982 ²¹	2	7 ³ / ₈	-	2 ¹¹ / ₁₆	8 1/2	1 ³ / ₄	-	-	20 ⁹ / ₁₆	27 ¹⁵ / ₁₆	14 1/2	1 ⁷ / ₈	1 1/4	50	270
1500	2455	6982-6982 ²¹	2 1/2	8	-	2 ¹¹ / ₁₆	9 ⁵ / ₈	1 ⁷ / ₈	-	-	20 ⁹ / ₁₆	28 ⁹ / ₁₆	14 1/2	1 ⁷ / ₈	1 1/4	50	300
1500	2455	6981-6981 ²¹	1	4	-	1 ⁵ / ₈	2	1.33	-	1/2	13 ³ / ₈	17 ⁷ / ₈	6	7/8	1	9	75
1500	2455	6981-6981 ²¹	1 1/2	5	-	2	2 ⁷ / ₈	1.92	-	1/2	16 1/2	21 1/2	11	1 ³ / ₈	1 1/16	26	115
1500	2455	6981-6981 ²¹	2	6	-	2 ¹¹ / ₁₆	3 1/2	2.41	-	5/8	20 ⁹ / ₁₆	26 ⁹ / ₁₆	14 1/2	1 ⁷ / ₈	1 1/4	49	238
1500	2455	6981-6981 ²¹	2 1/2	6	-	2 ¹¹ / ₁₆	4 ⁵ / ₁₆	2.91	-	5/8	20 ⁹ / ₁₆	26 ⁹ / ₁₆	14 1/2	1 ⁷ / ₈	1 1/4	49	238
2500	3206	6983-6983 ²¹	1	4	-	1 ⁵ / ₈	2 1/4	1.33	-	1/2	13 ³ / ₈	17 ⁷ / ₈	6	7/8	1	9	75
2500	3206	6983-6983 ²¹	1 1/2	5	-	2	3 ¹ / ₄	1.92	-	1/2	16 1/2	21 1/2	11	1 ³ / ₈	1 1/16	26	115
2500	3206	6983-6983 ²¹	2	6	-	2 ¹¹ / ₁₆	3 ³ / ₈	2.41	-	5/8	20 ⁹ / ₁₆	26 ⁹ / ₁₆	14 1/2	1 ⁷ / ₈	1 1/4	49	238
2500	3206	6983-6983 ²¹	2 1/2	6	-	2 ¹¹ / ₁₆	4 1/2	2.91	-	5/8	20 ⁹ / ₁₆	26 ⁹ / ₁₆	14 1/2	1 ⁷ / ₈	1 1/4	49	238

NOTES:

1. Hardseat-seatless
2. Hardseat-hardseat

YARWAY BLOW-OFF VALVES

SEATLESS, HARDSEAT AND UNIT TANDEM

HARDSEAT-SEATLESS UNIT TANDEM VALVES

FIGURE 3947-3927

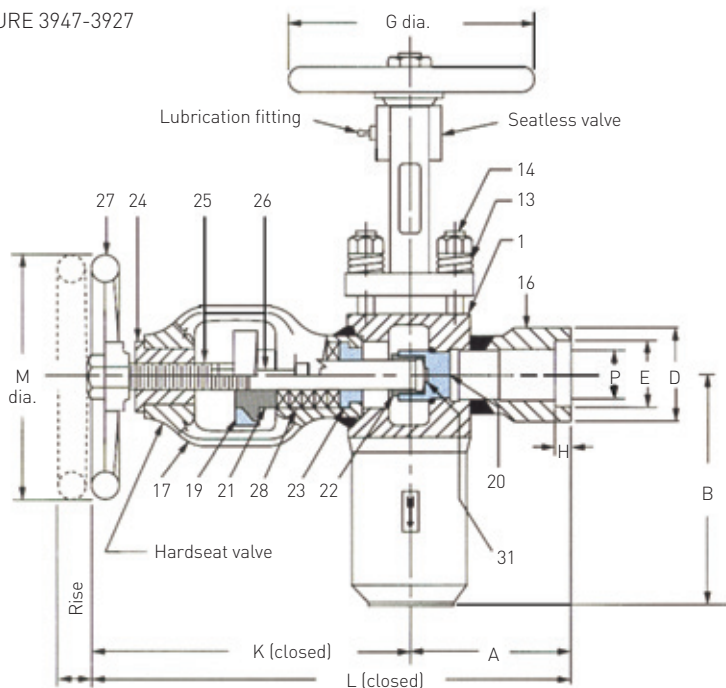
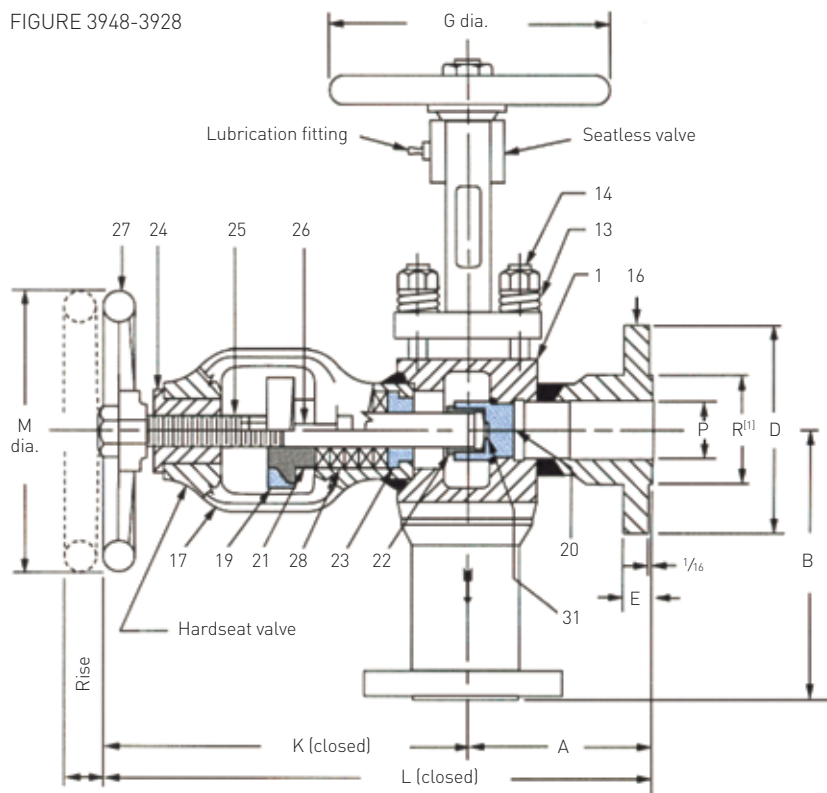

FIGURE 3948-3928



NOTE

1. See page 3 "diameter of raised face" (in flange dimensions table) for "R" dimensions.

YARWAY BLOW-OFF VALVES

SEATLESS, HARDSEAT AND UNIT TANDEM

HARDSEAT-SEATLESS UNIT TANDEM VALVES

FIGURE 6978-6954

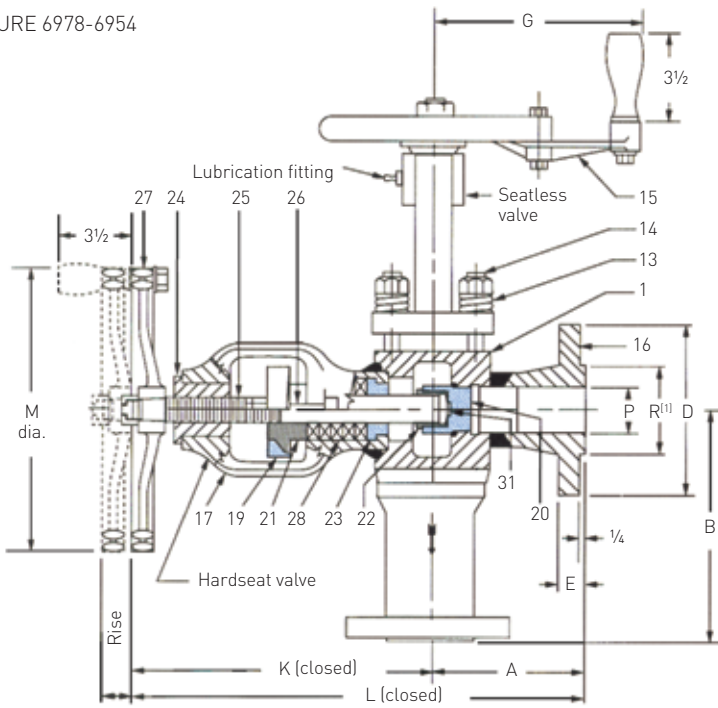

NOTE

1. See page 3 "diameter of raised face" (in flange dimensions table) for "R" dimensions.

FIGURE 6977-6953

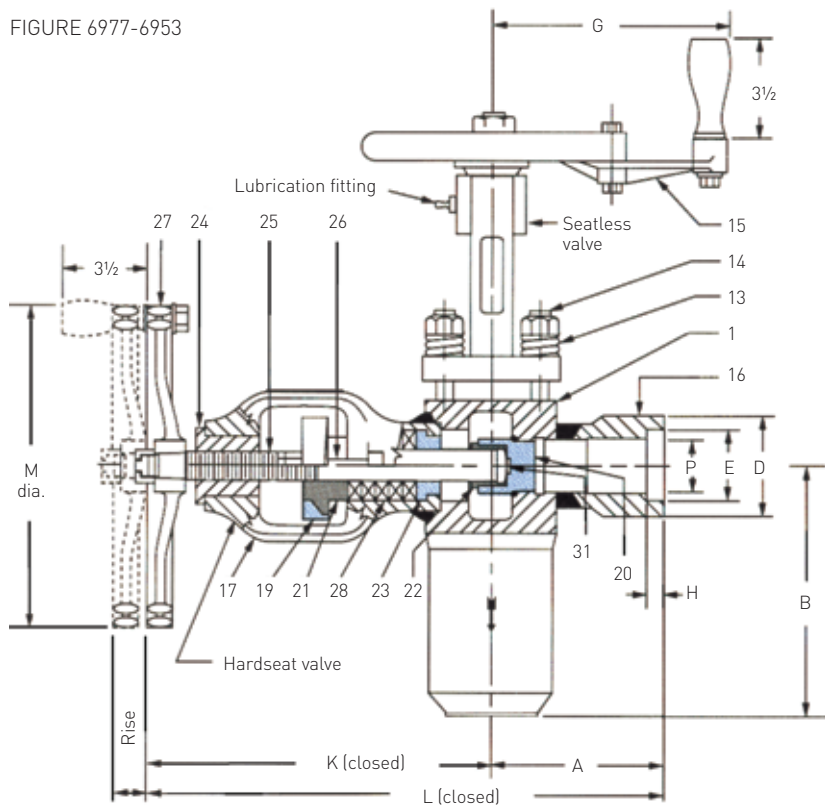

YARWAY BLOW-OFF VALVES

SEATLESS, HARDSEAT AND UNIT TANDEM

HARDSEAT-HARDSEAT UNIT TANDEM VALVES

FIGURE 6977-6977

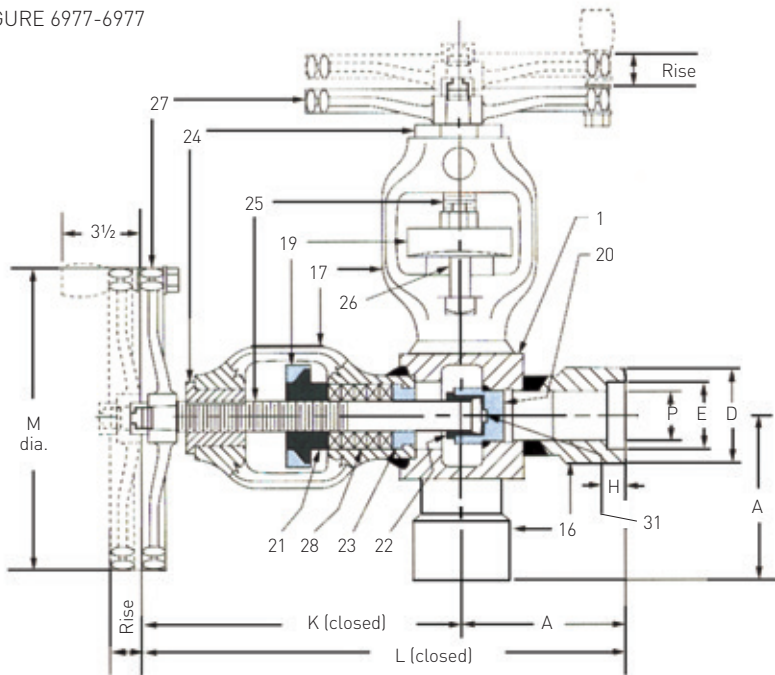
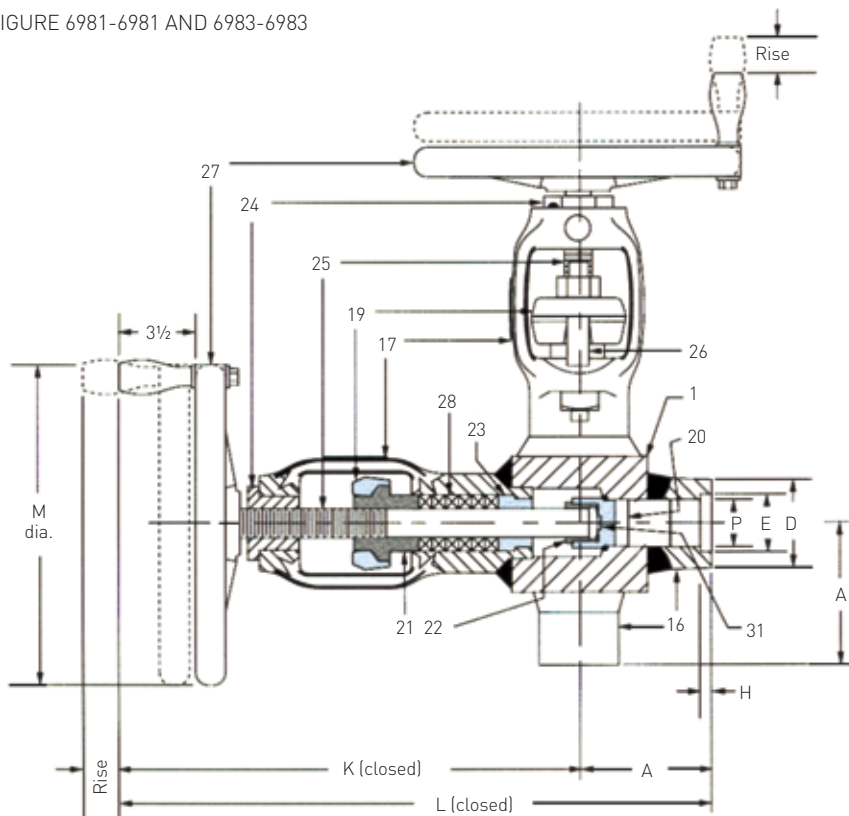

FIGURE 6981-6981 AND 6983-6983



YARWAY BLOW-OFF VALVES

SEATLESS, HARDSEAT AND UNIT TANDEM

HARDSEAT-HARDSEAT UNIT TANDEM VALVES

FIGURE 6978-6978

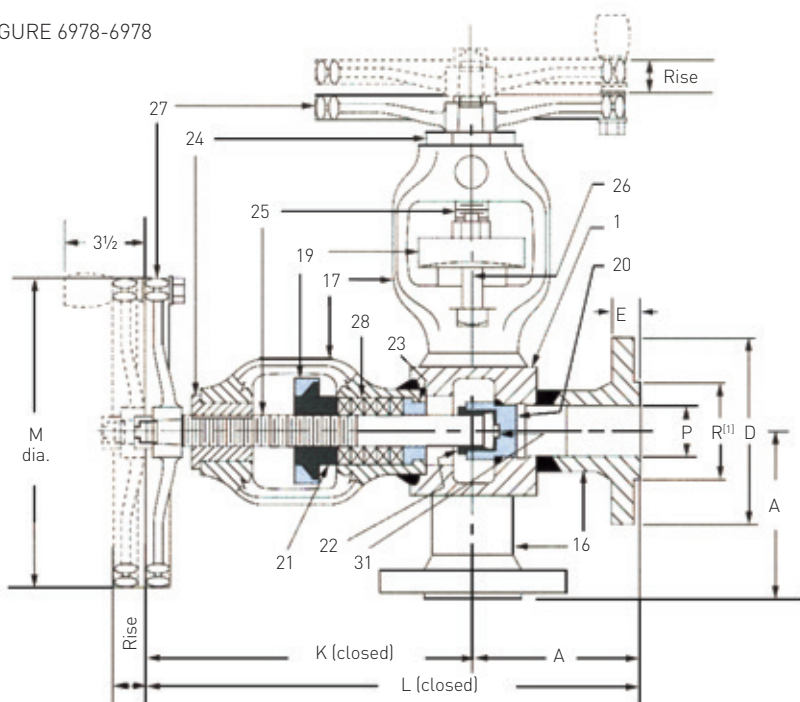
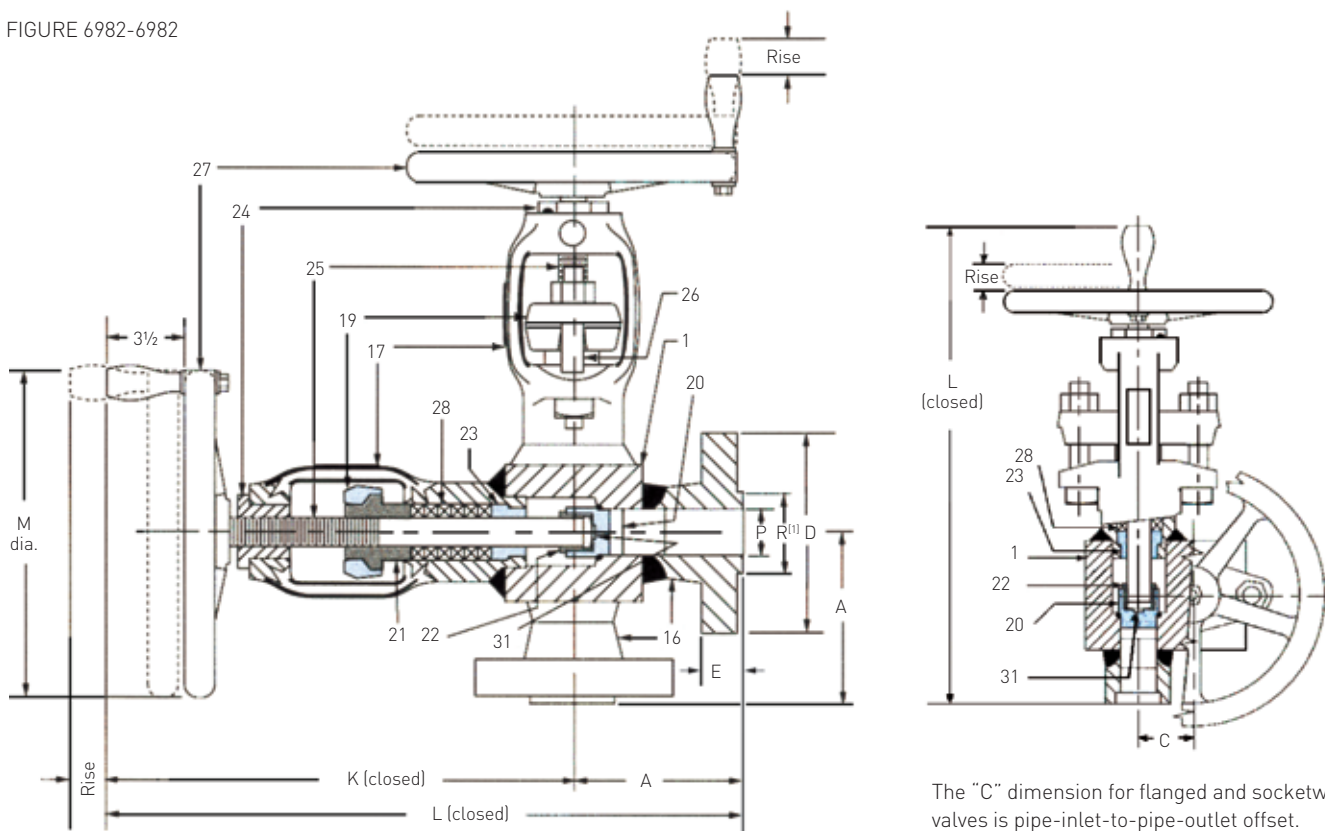

FIGURE 6982-6982



The "C" dimension for flanged and socketweld valves is pipe-inlet-to-pipe-outlet offset.

NOTE

1. See page 3 "diameter of raised face" (in flange dimensions table) for "R" dimensions.

