

CPB-460EN

# SERVICE CONDITIONS AND WARRANTY GUIDELINES

---

AGRICULTURAL TRACK

Including Drive Wheels, Idlers, Midrollers



This page intentionally left blank

# Contents

<b>1</b>	<b>INTRODUCTION</b>	<b>5</b>
<b>2</b>	<b>RUBBER TRACK SYSTEM TERMINOLOGY</b>	<b>5</b>
2.1	Friction Drive System	5
2.2	Positive Drive System	6
2.3	Non-Powered System	6
2.4	Track Construction	7
<b>3</b>	<b>PRODUCT IDENTIFICATION</b>	<b>8</b>
3.1	Track	8
3.2	Wheels	8
<b>4</b>	<b>TRACTION LUGS / TREAD BARS</b>	<b>9</b>
4.1	Typical Wear Patterns / Characteristics	9
4.2	Warrantable Conditions	11
4.2.1	Smooth Base Separation	11
4.2.2	Delamination	12
4.3	Non-Warrantable Conditions	13
4.3.1	Internal Reversion/Blowout	13
4.3.2	Mechanical Damage	14
4.3.3	Abrasion, Erosion, or Chunking Damage	15
4.3.4	Flex / Base Cracks	16
4.3.5	Stubble Wear	17
4.3.6	Inboard Edge Break-In Wear	18
4.3.7	Tread Bar Fatigue Cracks	19
4.3.8	Tread Bar Cupping / Trailing Edge Wear	20
<b>5</b>	<b>GUIDE OR DRIVE LUGS</b>	<b>21</b>
5.1	Typical Wear Patterns/Characteristics of Guide Lugs	21
5.2	Typical Wear Patterns/Characteristics of Drive Lugs	22
5.3	Track repair with missing or damaged guide lugs	23
5.4	Warrantable Conditions	24
5.4.1	Smooth Base Separation	24
5.4.2	Drive Lug Loss (Split Lug)	25
5.4.3	Reinforcement Layer Separation (Reinforced Drive Lugs)	26
5.5	Non-Warrantable Conditions	27
5.5.1	Torn or Jagged Separation	27
5.5.2	Side Wear (Misalignment/Side loads)	28
5.5.3	Break-In Wear (Lack of Dust or Wet Conditions)	30
5.5.4	Repeated Tip Damage	31
5.5.5	Corner Separation (Guide Lugs)	32
5.5.6	Reverse Face Wear (Drive Lugs)	33
5.5.7	Ratcheting Damage (Drive Lugs)	34
5.5.8	Base Cracks (Drive Lugs)	35
5.5.9	Reinforcement Layer Exposure (Drive Lugs)	36
<b>6</b>	<b>CARCASS</b>	<b>37</b>
6.1	Typical Wear Patterns / Characteristics	37
6.2	Warrantable Conditions	38
6.2.1	Carcass Separation (Traction Lug Side)	38
6.2.2	Carcass Separation (Localized Section)	39
6.2.3	Distorted Carcass	40
6.3	Non-Warrantable Conditions	41
6.3.1	Main Cable Failure (Wheel Path Tear)	41
6.3.2	Stubble Wear or Abrasive Damage	43
6.3.3	Internal or External Carcass Damage (Chunk, Cracks)	44

6.3.4	Internal Splits in the Carcass.....	45
6.3.5	Wheel Path Separation—Friction Drive (Due to Material Buildup).....	46
6.3.6	Wheel Path Separation—Positive Drive (Due to Material Buildup).....	47
6.3.7	Mechanical Edge Damage .....	48
6.3.8	Exposed or Loose Main Cable .....	49
6.3.9	Carcass Ribbon Separation .....	50
6.3.10	Wheel Path Wear (Internal surface) .....	51
6.3.11	Loss of alignment .....	52
6.3.12	Track Noise (Snapping or clicking) .....	53
<b>7</b>	<b>COSMETIC DEFECTS .....</b>	<b>54</b>
7.1	Tread bar .....	54
7.2	Drive Lug.....	55
7.3	Guide Lug .....	56
7.4	Carcass.....	57
<b>8</b>	<b>TREADBAR WEAR ESTIMATION CHART.....</b>	<b>58</b>
<b>9</b>	<b>ELASTOMERIC COATED WHEELS.....</b>	<b>59</b>
9.1	Wear Characteristics of Coated Wheels.....	59
9.2	Midroller Replacement Criteria .....	61
9.3	Warrantable Conditions.....	62
9.3.1	Smooth Separation – (Drive wheel).....	62
9.3.2	Smooth Separation (Idler / Midroller) .....	63
9.3.3	Pitting or Chunking (Drive wheels) .....	64
9.4	Non-Warrantable Conditions .....	65
9.4.1	Grinding or Polishing Wear .....	65
9.4.2	Metal Cracks .....	66
9.4.3	Coating Separation – Excessive Heat (Midroller) .....	67
9.4.4	Outboard Edge Wear (Midrollers).....	68
9.4.5	Stuck Wheel (Midroller).....	69
9.4.6	Mechanical Damage.....	70
9.4.7	Rubber Splitting / Tearing (Idler) .....	71
<b>10</b>	<b>DISABLING TRACKS AND WHEELS FOR WARRANTY .....</b>	<b>72</b>
10.1	Track and Wheels Disabling .....	72
<b>11</b>	<b>TRACK STORAGE GUIDELINES.....</b>	<b>73</b>
<b>12</b>	<b>TRACK SYSTEM INSPECTION PROCESS.....</b>	<b>75</b>
<b>13</b>	<b>GLOSSARY OF STANDARDIZED TRACK SYSTEM TERMINOLOGY.....</b>	<b>76</b>

# 1 Introduction

The purpose of this guide is to provide information regarding rubber track system warrantable and non-warrantable conditions. Descriptions are presented to allow the dealer to better understand the causes of both types of failures. Recommendations on track and wheel replacement versus continued usability are suggested, as well as comments to help minimize further damage.

Rubber track systems are used in a wide variety of applications and operating conditions. Various types of damage may occur during service life. In most cases where damage has occurred, repair is not necessary or feasible. Many times wear or damage only results in poor aesthetics. Operational functionality and performance, however, remain intact. In other cases, damage is severe enough to justify replacement.

This guide categorizes typical wear patterns or damage found as a result of normal use as well as accidental damage or damage resulting from misuse. Guidelines are provided for assessing the need for replacement, and recommendations are made for damage prevention to ensure that the maximum track service life is realized.

## 2 Rubber Track System Terminology

In order to use this guide, many system and component terms referenced throughout this document must be understood. The following section discusses these terms.

### 2.1 Friction Drive System

Track systems which use the frictional force between the drive wheel and track are known as friction drive systems. Friction drive systems rely on the coefficient of friction between rubber and rubber, or rubber and steel, along with high track tension, to transmit the tractive force of the machine from the drive train to the track.

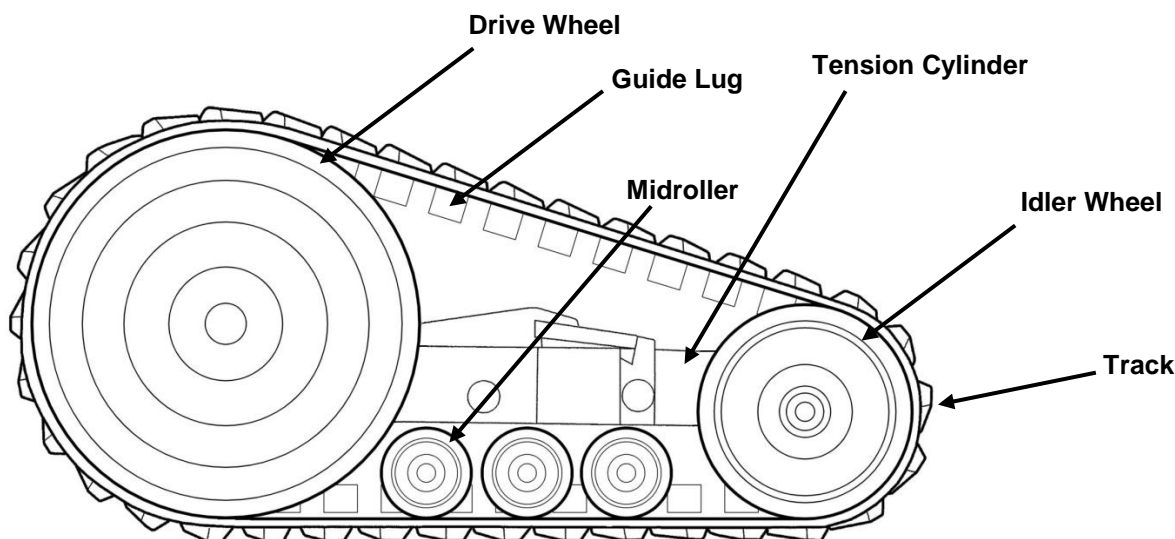

**Major components of a typical friction drive track system**

## 2.2 Positive Drive System

A track system which uses the drive lugs inside the track to transmit a portion or all of the torque to the track is known as a positive drive system.

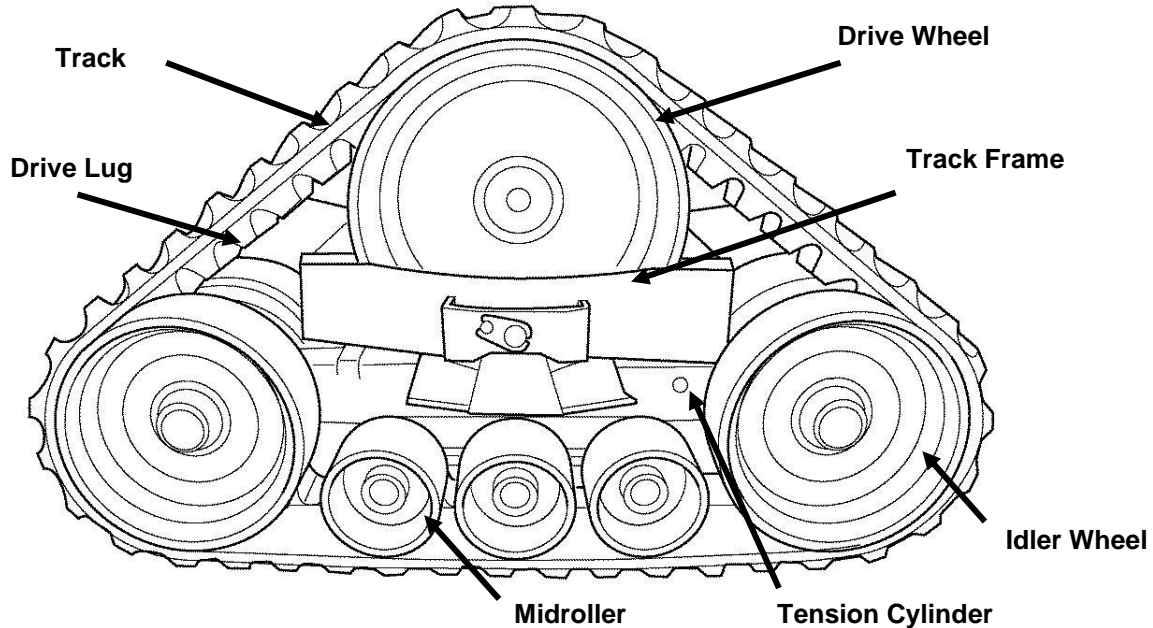

Major components of a typical positive drive track system

## 2.3 Non-Powered System

A track system which uses the track to carry only the load of the machine and does not transmit power to the ground is known as a non-powered track system.

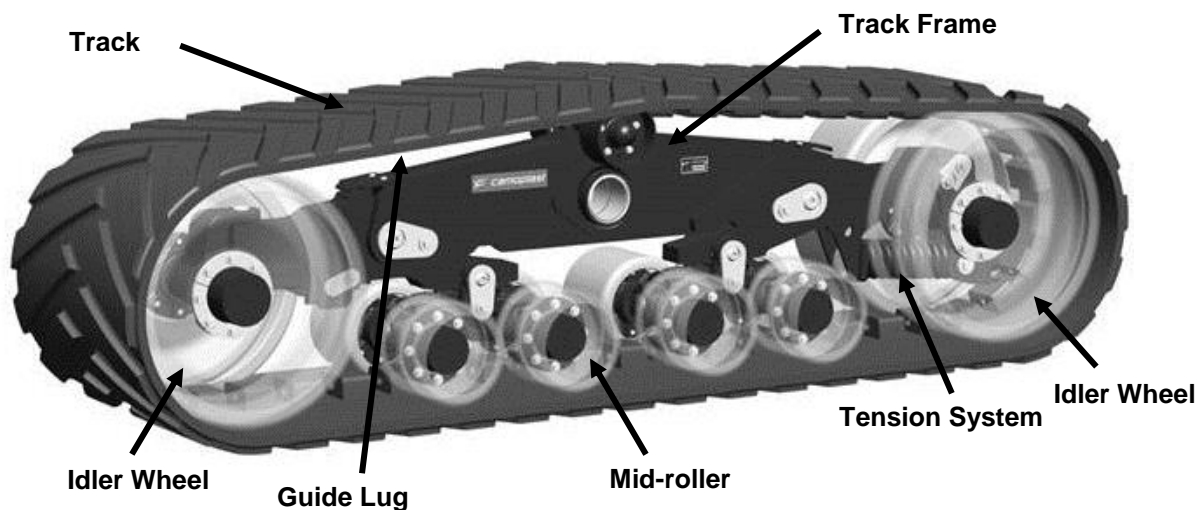

Major components of a typical non-powered track system

## 2.4 Track Construction

The illustration below shows some of the basic terminology used when referring to an agricultural track. For additional definitions of the track system terms used throughout this document, refer to [Appendix A – Glossary of Standardized Track System Terminology](#).

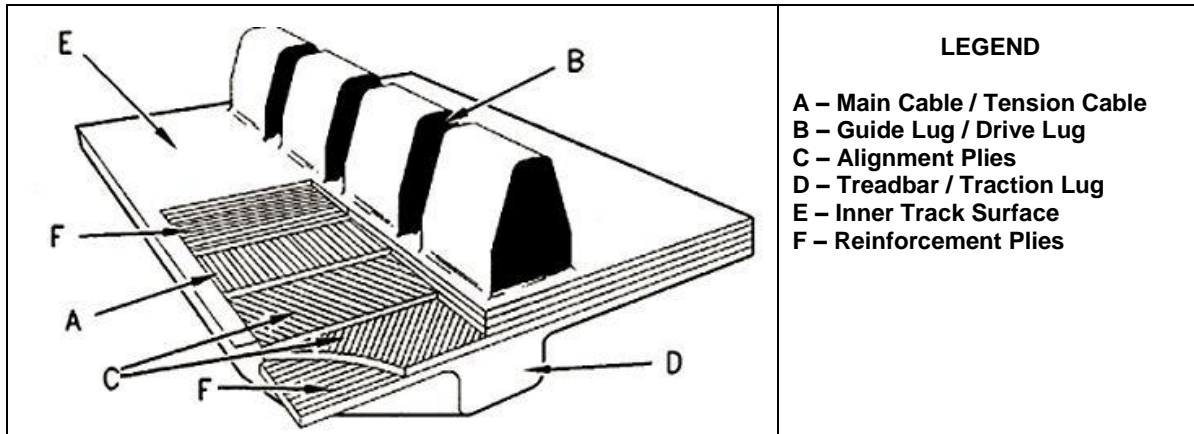

Camso tracks are constructed using a combination of natural and synthetic rubber, steel plies and a high tensile continuous wound main cable. The main cable gives the track tension strength, while at the same time maintaining lateral flexibility. The alignment and reinforcement plies protect the carcass, provide uniform track alignment, and increase lateral stiffness to better distribute loads across the track width. The tread bars are molded into specific shapes and sizes depending on the application, and guide and drive lugs come in various shapes and sizes depending on the requirements of the track design.

### 3 Product Identification

#### 3.1 Track

Track part and serial numbers are located on both sides of the track on the edge of the carcass. There may be 1 or 2 part numbers, depending on if the track is sold through more than one sales channel. When determining warranty eligibility, **all** information contained on the track identification strip should be provided.

##### Multiple Sales Channel Identification



Camso P/N                      Serial Number                      OEM P/N

##### Single Sales Channel Identification

Part Number                      Serial Number



#### 3.2 Wheels

Camso elastomeric coated wheels are not serialized, but use manufacturing date codes to aid in traceability. The date codes are stamped into the steel portion of the wheel on the hub side.

<p><b>Manufacture Date (MMDDYY) (Drive wheels/Idlers/rubber midrollers)</b></p>	<p><b>Manufacture Date (PMMDDYY HH:MM) (PU midrollers)</b></p>



## 4 Traction Lugs / Tread Bars

### 4.1 Typical Wear Patterns / Characteristics

Tread bar wear is a result of two different wear mechanisms:

1. **Abrasive action** during the transfer of power to the ground
2. **Scrubbing action** as the tread bar leaves and enters ground contact, or when turning on hard surfaces.

Several factors will influence tread wear:

- |                                |   |
|--------------------------------|---|
| • Amount of roading            | (Roading dramatically increases wear)             |
| • Track Width/Wheel Package    | (Wheels narrower than track cause uneven wear)    |
| • Track width                  | (Narrower track generally wears at a faster rate) |
| • Field soil conditions        | (Abrasive conditions increases wear)              |
| • Ballast weight /distribution | (Out of balance causes uneven tread wear)         |
| • Maximum drawbar pull         | (Higher slip levels increases wear)               |
| • Operational techniques       | (Can either decrease or increase wear)            |

#### Transport / Roading Wear

Tread wear rate increases significantly during roading operations. It is important to minimize the distance and duration of high speed roading whenever possible. If long distances must be covered, consider transporting rather than roading. If roading must be done, tread bar wear rates can be reduced by staying off pavement, reducing transport weight and speed, and adjusting machine balance for even weight distribution front to back. The greatest rate of tread wear occurs on a hot day with a poorly balanced, heavy machine. If possible, transport during cooler parts of the day and at reduced travel speeds and with minimum ballasted weight, as this will lower temperatures of the treads, guide lugs, and rolling components.

Unbalanced machines, especially ones with a lot of transport or roading time, exhibit more pronounced “leading” or of “trailing “edge wear. By properly balancing the tractor while under operation, this type of uneven wear may be minimized.

#### IMPORTANT

Some track tractors have transport speed restrictions based on axle weight. Refer to the track machine operators manual and posted decals for transport speed limitations, and stay below these limits, or track and track system damage can result.

Transport during the track break-in period (1<sup>st</sup> season) above 10 mph should be avoided. Transport speeds and duration, if required during this time, should be well below posted limits as track damage is much more likely during the break-in period

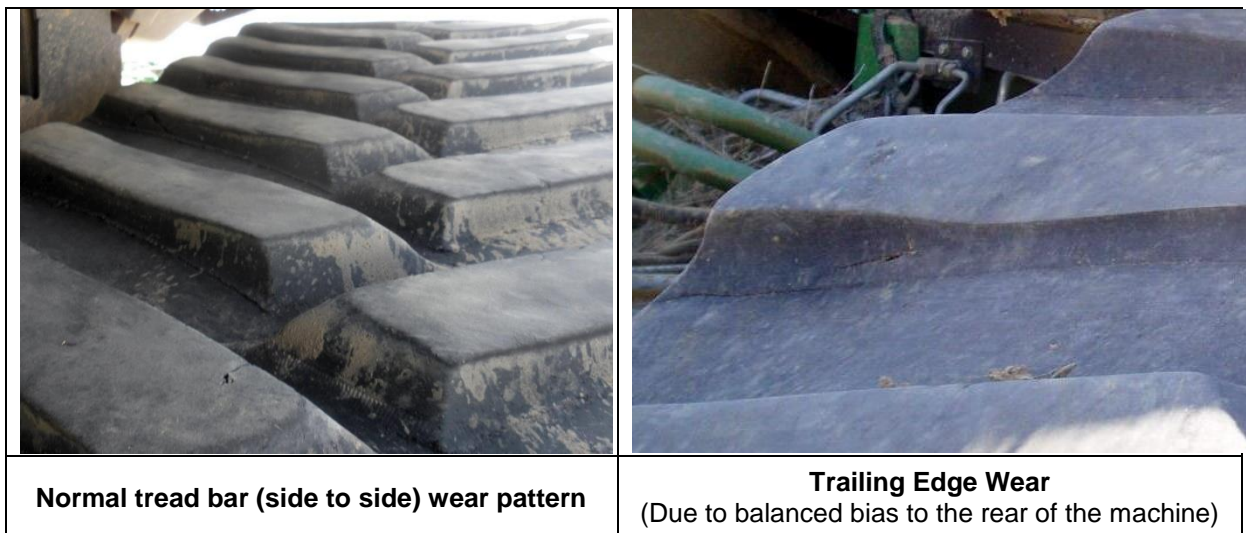

### Wheel Path Wear

Tread bars will also wear at different rates across the track width. This is because the area with the highest wear rate is under the highest load – this highly loaded area of the track is called the wheel path. It is normal for the inboard side of the track to wear faster than the outboard side, due to axle deflections, curvature of the road surface, etc... Tread bars will also wear faster on one side of the machine if always turned the same direction during field operation. If turning occurs frequently in only one direction, rotating tracks seasonally will even out tread wear.

Wear rate is increased by high slip and high vertical loads. Operation with wider tracks and wide wheel packages (if available) will lower wear rates and also lower temperatures during roading or transport. Because of this, always operate with the widest tracks available, and appropriate for the application. Uneven tread wear caused by using narrow midrollers with wide tracks may also cause higher vibration levels and flex damage to the carcass, so always use the widest midrollers available for the track.



## 4.2 Warrantable Conditions

### 4.2.1 Smooth Base Separation

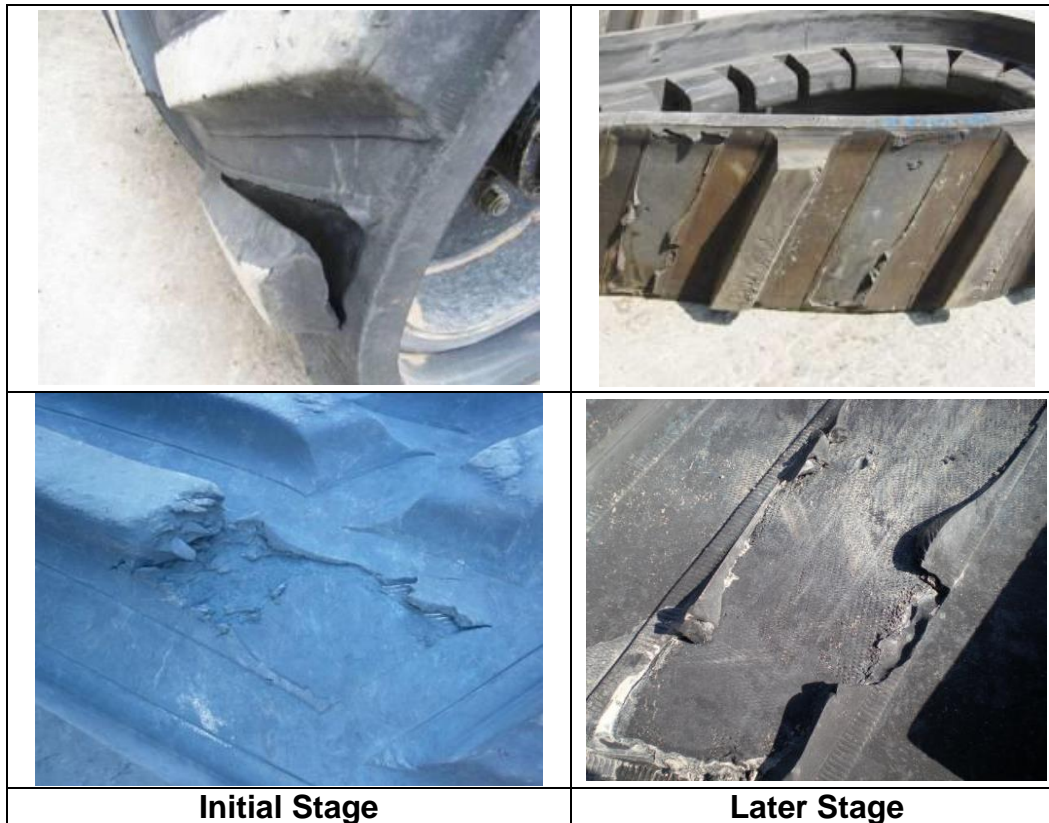

**WARRANTY CAUSE:** Poor adhesion due to contamination or improper cure

**APPEARANCE:** Failure is indicated by smooth surface at the tread bar to carcass interface, in some cases with jagged tears at the tread bar ends and outer edges

**WARRANTY:** YES (if more than 25% of the tread bar is separated smoothly)

If a loose tread bar is noted for any reason (either from a defect or from non-smooth separation due to mechanical damage), make sure to trim any loose portion to minimize the chances of additional track damage if the loose tread bar is torn off.

Trimming may be done by putting the rubber in tension in the area you would like to cut. Then using a sharp knife, make small cuts and slowly cut through the smallest section in order to separate the loose piece.

There is not an effective available field repair available to reattach such a traction lug separation.

#### **MINOR SEPARATION**

**WARRANTY:** NO (Less than 25% of total tread bar separation)

Minor separation is considered cosmetic and the track life will not be affected. Any loose portions should be trimmed to avoid further track damage.

## 4.2.2 Delamination

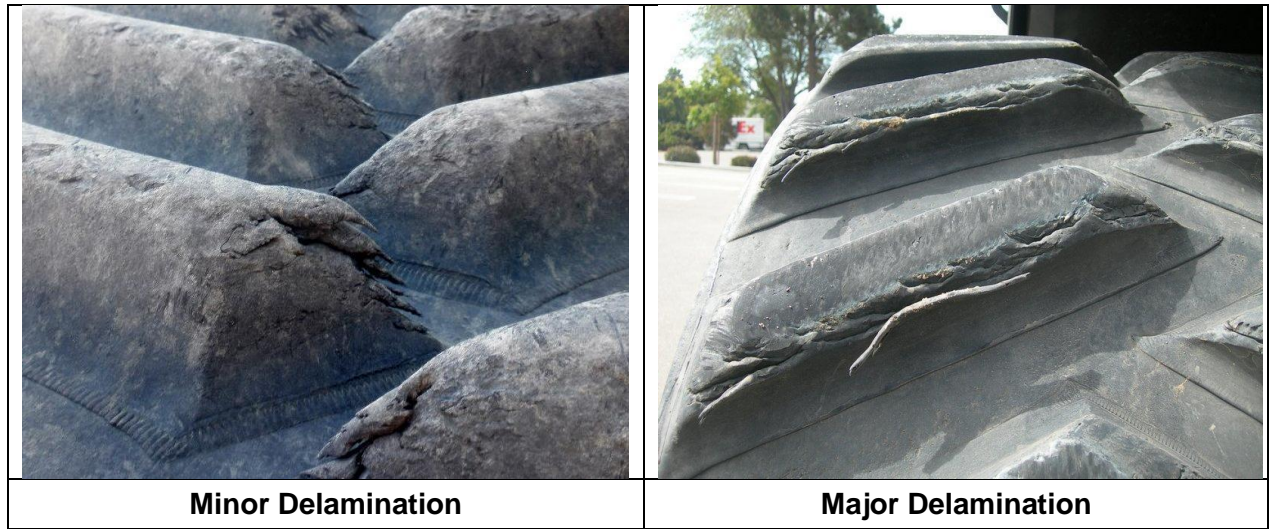

**WARRANTY CAUSE:** Incomplete or improper cure, or contamination, poor source material.

**APPEARANCE:** This type of failure will usually be noted throughout all tread bars on the track, although it may be to differing degrees. The rubber material may separate in more than 1 layer as wear continues.

**WARRANTY:** YES. However, the following criteria should be met in order to qualify a claim:

- A significant number of the tread bars should exhibit the defect
- Defect will significantly reduce track life (see above under Major Delamination)

### Minor Delamination

**WARRANTY:** Normally NO. However documentation may be filed.

Cases of track exhibiting a minor degree of delamination should be viewed as a cosmetic defect, as this will not significantly reduce overall track life.

## 4.3 Non-Warrantable Conditions

### 4.3.1 Internal Reversion/Blowout

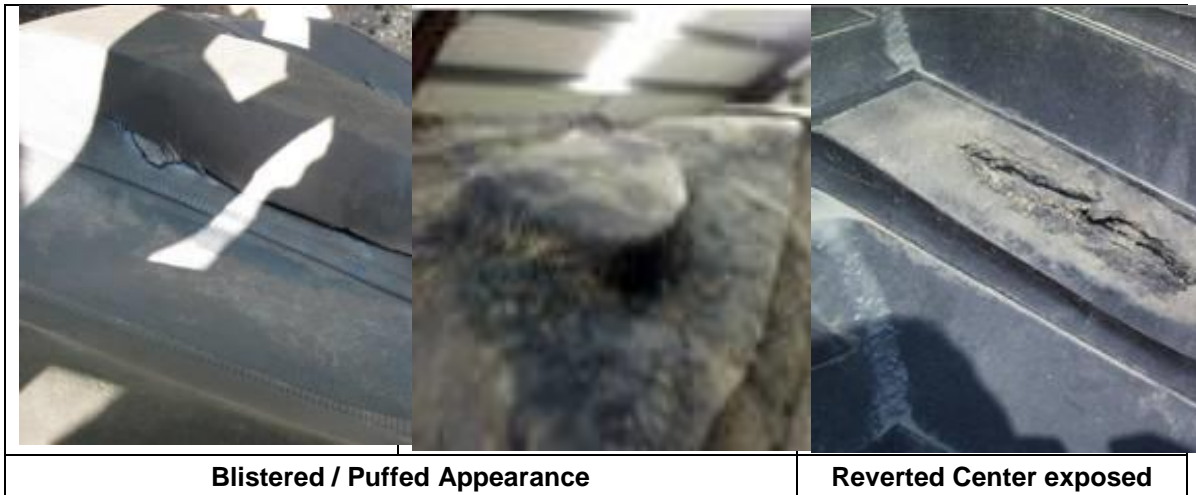

**NON-WARRANTY CAUSE:** Excessive internal heat buildup caused by high loads combined with extended transport or roading.

**APPEARANCE:** Tread bar appears to blister and swells up. Eventually with further heat input it can split open. Inside appearance shows rubber which has been reverted into a soft, sticky consistency. Many times associated with failed midrollers as well.

**DISCUSSION:** Heat is generated during operation from alternatively compressing and releasing tread bars over time. The higher the temperatures, and the more compression cycles in a fixed time the tread bar is subjected to, the greater the internal heat buildup.

Condition of which some or all may be present could include:

- Narrow track and narrow midrollers
- Highly ballasted machine
- Significant amounts of high speed roading
- Running 1 track on pavement and other on shoulder
- High ambient conditions
- Heavy hitch (fully mounted), vertical drawbar loads, or saddle tanks
- Incorrect air suspension pressure (if applicable)
- Highly crowned roads

**PREVENTION:** This type of damage can be prevented by doing the following:

- Reduce maximum roading speeds especially in high ambient conditions
- Reduce laden weight during roading (remove vertical drawbar load, fully mounted implements, remove headers, empty grain or chemical tanks, etc.)
- Travel on gravel roads instead of pavement and at cooler times of the day
- Balance machine to distribute evenly the weight on the track system

### 4.3.2 Mechanical Damage



**NON-WARRANTY CAUSE:** Mechanical damage

**APPEARANCE:** Tearing through more than one track layer, or smooth cut in one area through several layers. This can indicate a slice by a sharp object such as an implement disk blade. Driving over a sharp object under load may also show several consecutive tread bars with similar damage.

**DISCUSSION:** Mechanical damage may be misdiagnosed as smooth base separation if an entire tread is torn off. The difference is that the base is a jagged tear into the track carcass. Investigate cause of damage to help correctly determine the root cause of failure. Look for visual signs such as rubber marks on the implement.

**PREVENTION:** Careful operation is needed when using rubber components near sharp objects. Damage may frequently occur when carelessly offloading from a railcar or a trailer. Watch for sharp objects and avoid them. Sharp turns into an implement (RH upper photo) can also result in similar damage.

To prolong track life, loose tread rubber should be cut off to prevent additional tearing into the adjacent tread or carcass.

### 4.3.3 Abrasion, Erosion, or Chunking Damage



**NON-WARRANTY CAUSE:** Highly abrasive or hard/irregular soil conditions

**APPEARANCE:** Chipping of tread bars, usually on both tracks but typically worse on the side most frequently used for turning. Usually the field conditions are recognizable as very abrasive, sharp, or large hard cloddy soil. Tread erosion wear (bottom LH photo) may be seen in abrasive soil conditions, such as gravel or sand, usually in conjunction with high drawbar loads. Usually the ground is very hard, causing little penetration of the tread

**DISCUSSION:** This type of damage is seen more frequently in dry land farming, where deep ripping causes large clods of soil to be present, or where on land or in furrow plowing has been done. It also can occur in construction applications, where there is more uneven terrain and frequent encounters with larger non-compressible and sharp objects. Operation in deep V shaped beds may also cause this type of wear on the outside half of the tread bar.

**PREVENTION:** Operation in less aggressive soil conditions, less clods, or less sharp objects.

**NOTE:** This type of damage will stop once the machine ceases operations in harsh conditions, or once the large hard soil clods are broken up.

### 4.3.4 Flex / Base Cracks



**NON-WARRANTY CAUSE:** Flex cracking generally occurs over time, and is due to rubber fatigue. This fatigue is caused by repeated flexing and bending loads as the track goes around the wheels, and from tread bar stresses due to tractive effort.

**APPEARANCE:** The track will generally not exhibit flex cracking until well into the lifetime of the track. Cracks are usually shallow, and only at the base of the tread bar. The crack extends into the upper layer of the carcass and may show some reinforcement cables

**DISCUSSION:** Flex cracking is generally more pronounced in tracks that are thicker, and in tracks installed on track systems with smaller diameter idlers or drive wheels.

Flex cracking will not have any effect on track life, as cracks will not propagate further before tread is worn out. It is normal for flex cracks to appear after track usage.

**PREVENTION:** Flex cracking can be accelerated in high ozone areas or in conditions where tracks are stored outside or in areas with heavy exposure to the sun. Flex cracking may be delayed by keeping tracks out of the sun and away from ozone when not in use.



### 4.3.5 Stubble Wear



**NON-WARRANTY CAUSE:** Track operation with aggressive crop stubble in the same location on the track for an extended period of time.

**APPEARANCE:** The tread bars and the carcass sections between them will usually show chipping damage down a narrow path of the track in a rowcrop application such as corn. Broadcast or drilled crop stubble wear can also be seen across the entire track surface. The chipping may eventually expose some outer track carcass reinforcement layers. The damage path will correspond with the location of the crop stubble.

**DISCUSSION:** Stubble wear can be more significant to specific varieties of crops which are resistant to organic breakdown. Wear can vary year to year depending on moisture conditions, speed of operation, or height the crop is being cut by the combine header. This damage is most prevalent in very aggressive crop stubble, such as sunflower, pineapple, or sugar cane, but can also occur in corn and bean stubble as well.

**PREVENTION:** Run between or diagonal to the crop stubble during the primary tillage pass if possible. When harvesting, cut crop close to the ground to minimize the stubble height, or cut higher and use of stalk stompers can also minimize this type of damage.

### 4.3.6 Inboard Edge Break-In Wear



**NON-WARRANTY CAUSE:** Operating in more aggressive or cloddy soil in high load / low ground penetration conditions, usually with new tracks

**APPEARANCE:** The tread shows some tearing in the inboard/center tread edge. It has been noted in a wide variety of applications, and can be anything from a shallow cut, to a small section of the tread torn away.

**DISCUSSION:** This type of wear can be associated with a variety of crop or operational factors. In some specific conditions, this cosmetic break-in wear will be evident for the first few hundred hours, but will eventually polish over and smooth the area out.

**PREVENTION:** None noted – mainly influenced by specific operational conditions.

### 4.3.7 Tread Bar Fatigue Cracks



**NON-WARRANTY CAUSE:** Due to high drawbar loads in hard soil conditions with little to no tread bar ground penetration

**APPEARANCE:** Cracks forming at ½” from the carcass. Cracks usually start near the center of the track and move outwards.

**DISCUSSION:** This type of wear is usually seen in applications with high drawbar loads, high tractor weight, and hard soil conditions such as fully mounted mold-board ploughs. In hard soil conditions where little to no tread bar penetration into the ground occurs, drawbar load is transferred to the ground using the tip of the tread bar instead of the face of the tread bar. This causes the tread bar to flex under the load and over time fatigue cracks to occur.

**PREVENTION:** None noted – mainly influenced by specific operational conditions.

### 4.3.8 Tread Bar Cupping / Trailing Edge Wear



**NON-WARRANTY CAUSE:** Undercarriage wheels apply localized loading into the track wheelpath and into a portion of the tread bars. Other factors that can cause tread bar cupping are soil conditions, long distance or long duration roading at high speeds, additional tractor ballasting, and high axle loads.

**APPEARANCE:** Cupping on the trailing edge of the tread bars, in the middle or towards the edge of the track. Location of cupping typically correlates to where the wheels are applying pressure to the track carcass. Track alignment can affect where the cupping occurs.

**DISCUSSION:** This type of wear is considered normal. The tread rubber wears faster in the localized area of the rolling stock footprint. Increased amounts of roading can accelerate this type of wear. Narrow tracks are more susceptible to this type of wear due to the reduced footprint of the narrow track and narrower wheels. Narrow wheels on wide tracks can result in the same cupping wear. This narrow wheel footprint increases the localized load on the track, accelerating the wear of the tread bars in that area.

**PREVENTION:** Always utilize the widest recommended rolling stock available for the track width being used.

## 5 Guide or Drive Lugs

There are two major types of guiding lugs, this being dependent on the track system design:

**Guide Lug** - The lug serves to retain the track, and carries no torque or tractive force. This type of lug is used in friction drive type track systems

**Drive Lug** - The lug serves to both retain the track and carry some or all of the torque or tractive force to the track from the drivetrain. This type of lug is used on positive drive type track systems.

### 5.1 Typical Wear Patterns/Characteristics of Guide Lugs

Initial guide lug break-in on new machines, or machines with new tracks installed, may take up to a few hundred hours of operation. Break-in on an in-service machine will usually take much less time, due to the presence of dirt on the existing track system and rolling components. The ideal operating condition for guide lug break-in is **dry and dusty soils**. Dust acts as a dry lubricant to assist in heat reduction and polishing in of the components.

---

#### CAUTION

Extended roading of a new track during the break-in period and especially prior to initial field use, even with correct alignment, is **not recommended**, and may lead to significant drive lug scuffing as well as midroller failures due to heat. Break-in wear is non-warrantable.

---

If damage is seen on both sides of the guide lug, it is usually caused by “**break-in**”. If damage is seen only on one side of the guide lug, it is usually caused by **misalignment**.



After break-in, guide lug appearance stabilizes and additional wear generally occurs on the leading edge. If guide lugs continue to wear, one of the following conditions may exist:

- Misalignment (due to adjustment or due to track system mechanical issues)
- Steep side slope operation
- Abrasive or sharp soil conditions
- Application induced side loading (such as construction)

## 5.2 Typical Wear Patterns/Characteristics of Drive Lugs

Typically, wear will be seen on the edges of the lugs and small cracks can develop at the corners of the lug as shown in the attached pictures. This condition is considered normal and not an indicator of drive lug overall life. The types of drive lug wear can vary depending on conditions and applications. Regardless of appearance, drive lugs are considered serviceable if more than 50% of the lug remains attached. If one drive lug is missing, the track can also remain in service but overall life will likely be reduced as loads will increase on the surrounding drive lugs.



**Typical Drive Lug Break-in Wear**



**Typical Drive Lug Mid-Life Wear**

As with all tracks alignment is critical for maximum track life. In addition to conditions and applications, drive lug life is highly dependent on the operator techniques used, especially in construction applications. Often small operational changes can extend service life considerably.

### **Drive Lug Operational Practices to Maximize Life**

In order to extend drive lug life (many times the track life limiting factor) customer should:

- Minimize high draft side loads. When under load, always operate in a straight line when possible; avoid operating on step side hills pulling heavy loads while turning. Avoid high speed turns on declines or with heavy implements in tow.
- Minimize full power application in low speed gears. Maintain speeds above 4-5 MPH.
- Monitor and correct track misalignment. New tracks may require frequent adjustments during the break-in phase. Check several times per day and make small adjustments until the track alignment stabilizes. Then continue to monitor tracks as part of daily maintenance schedule. If alignment cannot be maintained an undercarriage problem may exist. Address immediately.
- Keep drive wheel lug pockets and surfaces clear of material. Do not clear dried or frozen material by driving the machine or drive lug damage will result.
- If application results in reduced track life and conditions or operations cannot be changed or improved, rotate tracks left to right, or front to rear (if applicable/) to even out wear and help maximize track life.

### 5.3 Track repair with missing or damaged guide lugs



In situations where **guide lugs** are lost for a variety of causes, bolt-on guide lugs may be an economical alternative to track replacement. Guide lug replacement and reinforcement should only be done if the track economic life justifies it (amount of tread wear and carcass condition should be evaluated).

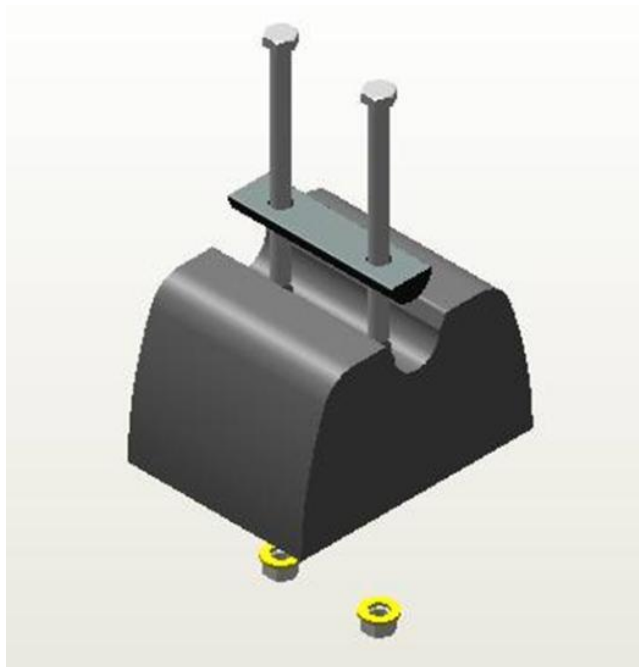

Camso has a patent pending bolt-on guide lug kit available for many track designs. See your dealer for more details

#### **CAN DRIVE LUGS BE BOLTED ON?**

It is not recommended that drive lugs on positive track systems be repaired using the bolt-on method, due to the exact placement tolerances and high loads. In most Agricultural applications, a single drive lug lost has not been found to be disabling, and in many cases several hundred hours additional life can be had before additional drive lugs are lost. This, tracks with random missing drive lugs should continue to run as long as possible to gain maximum track life

**NOTE:** Repair of drive lugs on positive drive tracks cannot be done using this method, due to the critical nature of proper positioning and timing.

## 5.4 Warrantable Conditions

### 5.4.1 Smooth Base Separation

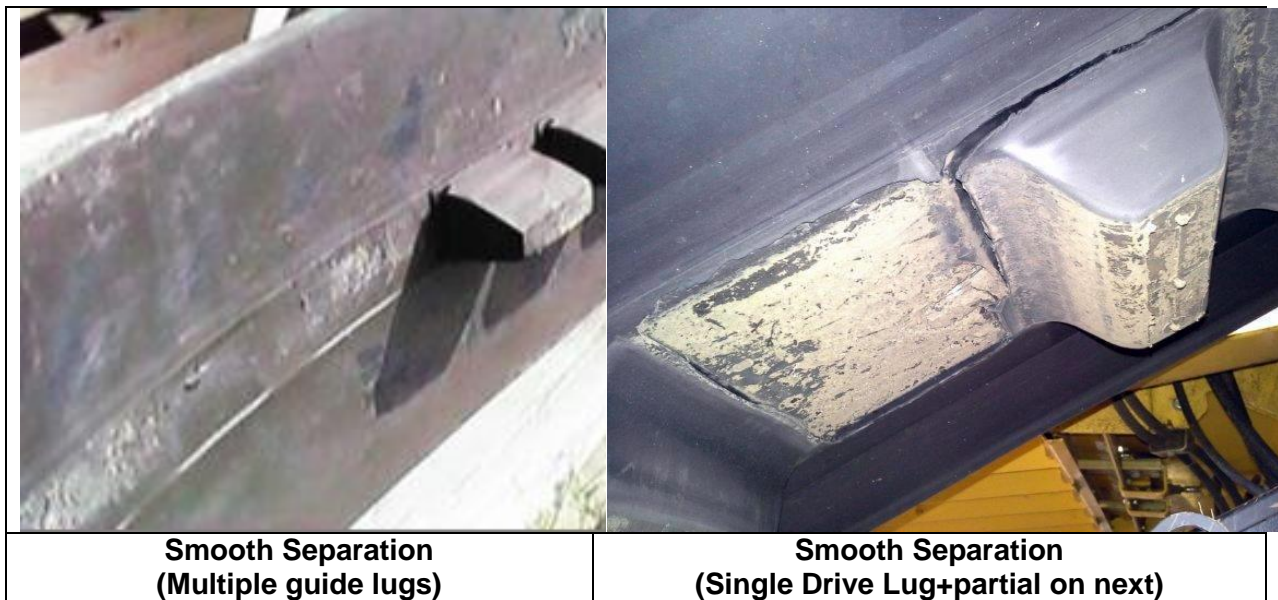

**WARRANTY CAUSE:** Poor manufacturing curing or contamination

**APPEARANCE:** Loss of guide or drive lugs due to contamination will usually exhibit a smooth or clean surface guide lug separation from the carcass. Little or no lug material will be adhered to the carcass.

**WARRANTABLE:** In most cases, YES. If the following conditions are met:

- At least 1 guide or drive lug is lost due to smooth separation
- Shows CLEAN or SMOOTH separation – jagged separation in center does not apply

**NOTE:** Remember, non-warrantable guiding lug damage does not necessarily render the track unusable. Use the track replacement criteria below to determine if the track can continue to run, or if track replacement/repair is required:

#### GUIDE LUG

- More than 3 consecutive guiding lugs are lost
- More than one quarter of the total number of guide lugs are lost

#### DRIVE LUG

- More than 25% of the total drive lugs engaged in drive wheel at once are missing



## 5.4.2 Drive Lug Loss (Split Lug)

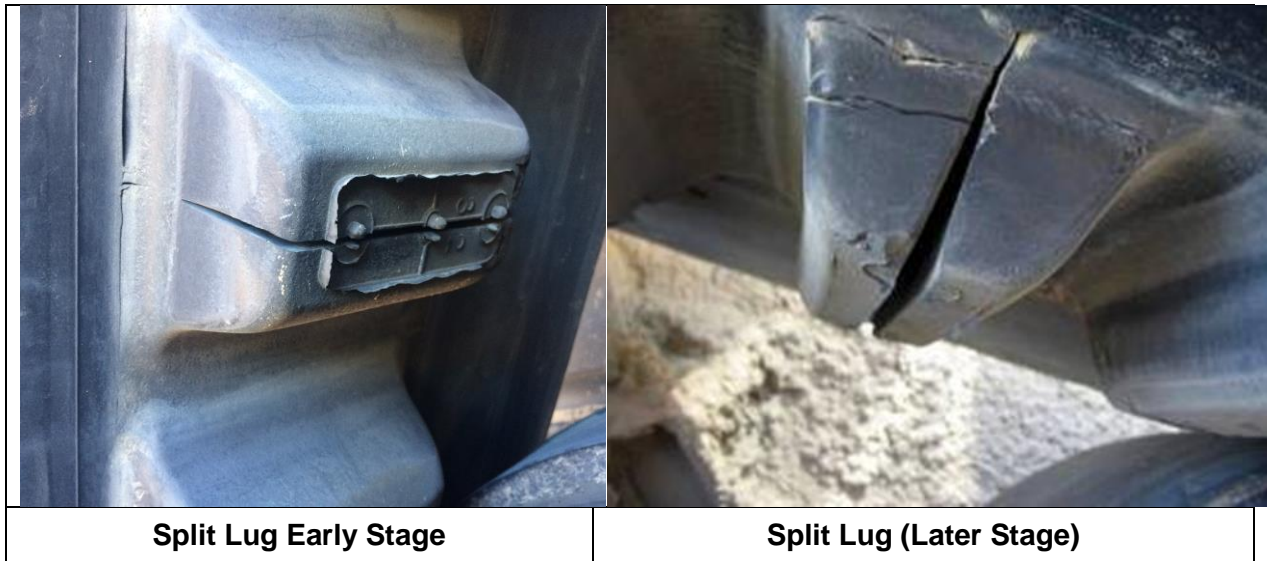

**WARRANTY CAUSE:** Contamination or incomplete cure

**APPEARANCE:** Clean separation in center of drive lug at mold line.

**WARRANTY:** YES. Any of the conditions below is considered a disabling defect:

- More than 1 drive lug 100% missing with evidence of being split
- More than 2 drive lugs with at least 50% of drive lugs missing due to split lug condition

**DISCUSSION:** Drive lugs can be lost due to several causes, not only due to a manufacturing issue. In order to qualify for this type of consideration, clear evidence that the drive lug split prior to its loss should be exhibited. If present, it usually can be seen as a split down the center of the drive lug, even if most or half of the drive lug is missing.

### 5.4.3 Reinforcement Layer Separation (Reinforced Drive Lugs)

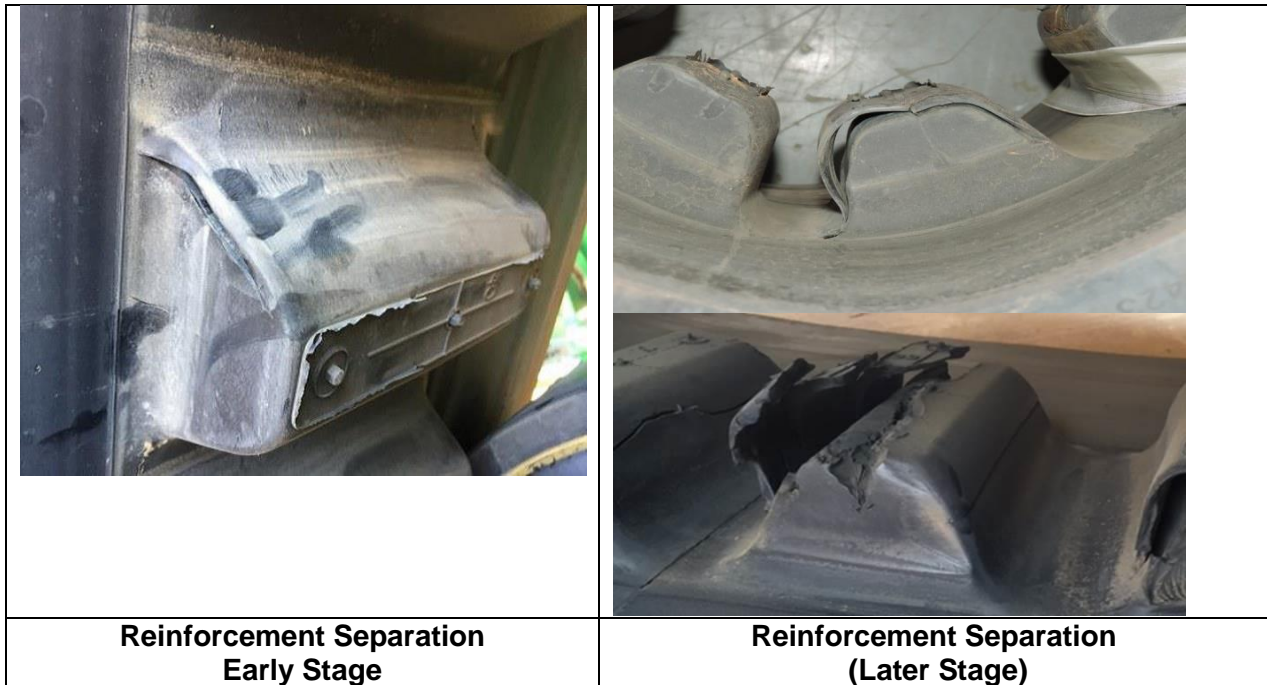

**WARRANTY CAUSE:** Incomplete manufacturing cure or contamination.

**APPEARANCE:** Outer layer of drive lug rubber appears to peel off, showing smooth separation from the fabric reinforcement layer or drive lug rubber.

**WARRANTABLE:** YES – If the following condition is met:

- The fabric reinforcement material is loose across the entire width of the drive lug (confirm by inserting ruler from one side through to the other)

NO – If the following condition is met :

- The drive lugs have ratcheted through the drive wheel pockets and damaged the drive lugs enough to tear the fabric loose from the drive lug.

**DISCUSSION:** Drive lug damage can occur from side loading (misalignment), excessive torque, improperly sized drive wheels, excess material ingestion through the undercarriage, and low track tension. Drive lug damage may cause the fabric reinforcement layer to detach from the drive lugs, which would result in a non-warrantable failure. Before considering for warranty, verify track alignment is correct, track tension is correct, the drive wheel is the correct diameter, the application is not inducing excess material into the undercarriage, and the machine power output to the track system is not modified above and beyond approved levels using power chips, tuning etc.

## 5.5 Non-Warrantable Conditions

### 5.5.1 Torn or Jagged Separation



**Jagged Separation (Guide Lugs (LH) and Drive Lugs (RH))**

**NON-WARRANTY CAUSE (*Friction Drive/ Guide Lug*):** Mechanical damage to the guide lug due to object stuck in the track system, untracking, low track tension, or contact with track system component(s).

**NON-WARRANTY CAUSE (*Positive Drive/ Drive Lug*):** Drive lugs can also be damaged through mechanical means, or by ratcheting of the system due to high torque loads or material ingestion, or temporary loss of track tension. As the drive lugs ratchets, it pops in and out of the sprocket and causes substantial damage to the tips of the lug or cracks in the base of the lug. Untracking allows the drive lugs to climb on top of the idler or drive wheels causing track overtension and considerable drive lug damage.

**APPEARANCE:** Lugs are torn with jagged separation. Damage may be in groupings from interference with a large, one time piece of debris or from a track system component. Also, if untracking has occurred, in some cases, more extensive mechanical damage is seen, such as torn cables, lugs pulled off the track attached to base cables, crushing, and drive lug splitting.

**PREVENTION:** Keep sharp non-compressible material out of the track. Maintain correct track tension and alignment. Operate in a manner that will prevent untracking occurrences. Make sure tensioning system is free to move and is working correctly. Minimize amount of high draft side loads. Always pull or push straight, avoid operating on side hills and loading scrapers or pulling heavy loads while turning. Avoid high speed turns on declines or with heavy implements in tow. Also, inspect and replace midrollers with rubber missing.

Drive lugs can also exhibit jagged separation due to **track ratcheting**. Improper tensioning can cause ratcheting and must be corrected before track is replaced.

## 5.5.2 Side Wear (Misalignment/Side loads)

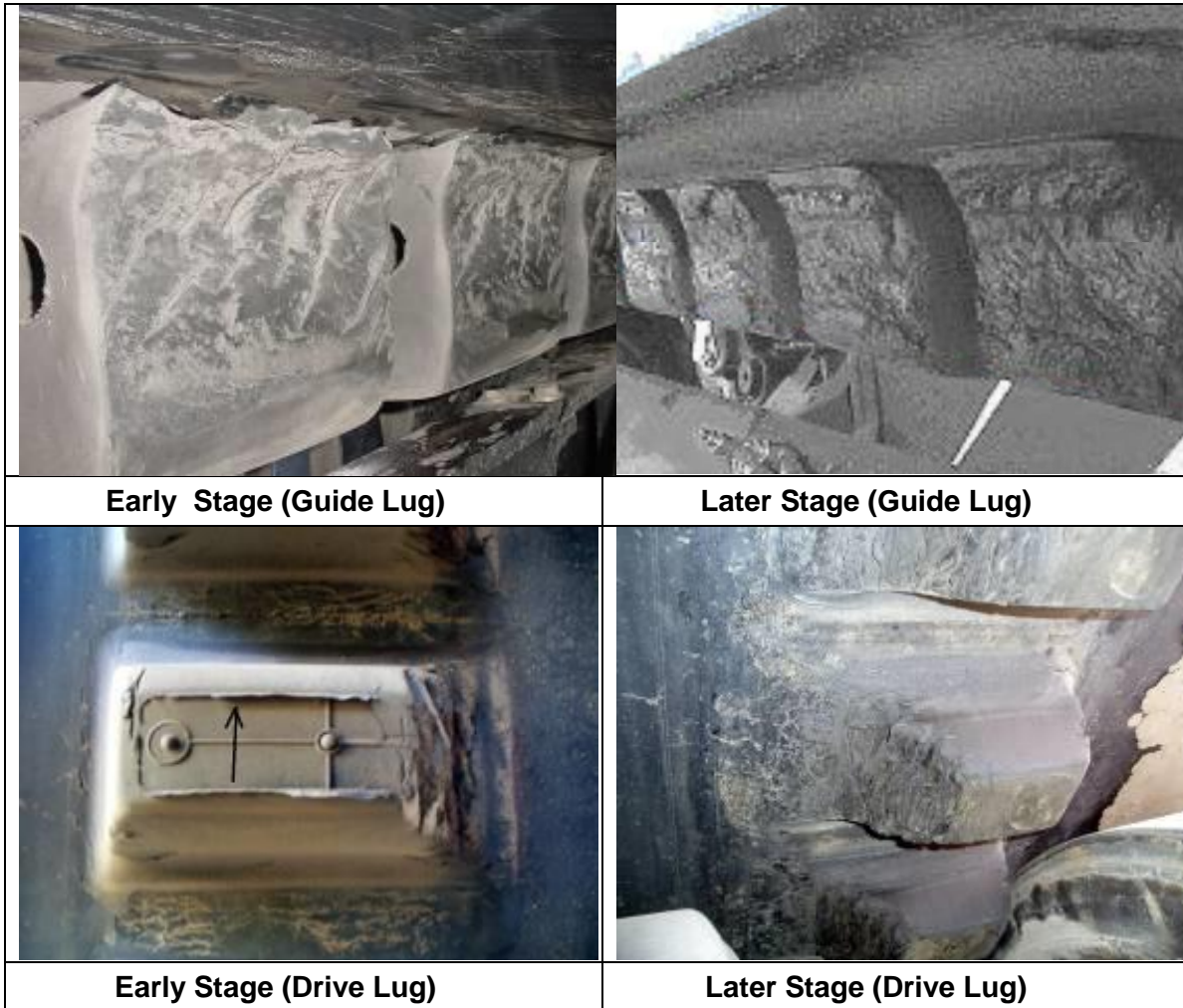

**NON-WARRANTY CAUSE:** Wear caused by a combination of the following conditions:

- Track misalignment
- Operation of track in extreme side hill conditions
- Poor mechanical condition of the track system
- Incorrect break-in procedures
- Internal track damage
- High side loads caused by turns with heavy drawbar loads such as scrapers or deep tillage, turn at speed or on declines with heavy towed implements
- Untracking /derailing causing the lug to climb on top of the idler or drive wheels

**APPEARANCE:** If the problem is due to misalignment or side hill operation, generally only one side of the guide lug will show damage. If improper break-in procedures have been followed, both sides of the guide lug could show scuffing damage.

**(Continued on next page)**

**DISCUSSION:** The source of track misalignment can either be due to improper alignment (most but not all machines have alignment adjustment), mechanical track system damage or wear in the track tension pivot assemblies, or uneven wear in the track system idler and midroller components.

It is important to identify the cause of the misalignment before the guide lug wear progresses too far. If track is run misaligned, especially when roading, guide lugs will run against the midrollers and generate heat. Excessive heat will eventually cause track damage including rubber separation, reversion, and midroller elastomeric coating loss.

Operation on steep side slopes will increase guide lug side loading and wear. Correct alignment is critical for operation in these conditions. In addition, operation of side slopes with narrow track is not recommended. When using tracks on side slopes, alternate track operation on the downhill side of the machine to help even out guiding lug wear. If the machine must always be operated with the same side downhill, consider periodically rotating the tracks.

If operating tracks on a very heavily loaded machine such as a combine, while turning with a very short turning radius (spot turning) it is possible to damage the inside alignment bias of the tracks. This can cause the track to become much more difficult to align, or to become misaligned after being aligned only a short time earlier.

**PREVENTION:** Always check the mechanical condition of the track and track system if guide/drive lug scuffing begins during machine operation for no apparent reason. Always inspect and repair as required before installing new tracks.

**NOTE:** Refer to the track machine Operation and Maintenance Manual (OMM) for more information on adjusting and maintaining track alignment. Track alignment is an owner maintenance responsibility and is not covered under warranty.

### 5.5.3 Break-In Wear (Lack of Dust or Wet Conditions)



**NON-WARRANTY CAUSE:** Rubber to rubber contact between guide lug and rolling components.

**DISCUSSION:** Guide lugs will show scuffing and wear on the leading edge in the area where rubber to rubber contact occurs. This type of damage is more likely to be seen with a new track on a new machine, during the break-in period, if insufficient dirt and or lubrication are used, if slightly misaligned, or in consistently wet conditions. It also can occur on a used machine with a replacement track if new midrollers, idlers, or drivers were also installed. New wheels may have rubber flash and this can increase the amount of scuffing until the flash is completely worn away.

**PREVENTION:** Operate in dry and dusty conditions as soon as possible. Avoid break in during very wet conditions. Do not transport machine without use of dry lubricant applied to the lug periodically until break-in is completed.

With new systems, or systems with new rolling stock, operate as much as possible in dry dusty conditions until the flash is removed, and minimize the amounts of high speed roading. Make sure to also check alignment and adjust if possible to minimize leading edge wear.

Periodically check alignment and inspect track system for damage that could cause misalignment. Alternate downhill sides in steep side slopes to equalize break-in wear on both sides of the guide/drive lug.

**NOTE:** All new tracks should be lubricated with dust or fine dirt prior to high speed road operation. A second and third application should be applied at 15 minute intervals if prolonged road travel cannot be avoided. A dry lubricant such as soil, talc, or "oil-dry" works well for this purpose, and can be applied periodically until exposure to field conditions commence. This is only necessary on new tracks - prior to break-in. The best practice for new tracks is to operate at field speed in dusty soil conditions as soon as possible.

## 5.5.4 Repeated Tip Damage



**NON-WARRANTY CAUSE:** Loose bolts, failure of track drive or alignment components or mechanical damage to guiding lugs due to rocks and debris caught in the track system or between the wheels. This damage can also be caused by operating with excessively worn midrollers or midrollers with missing elastomeric coatings, or from uneven tread wear forcing guiding lugs up into the track system.

**APPEARANCE:** Look for repeat gouging or chipping of guide or drive lugs. Frequently if untracking has occurred more extensive mechanical damage including crushing or scuffing will be seen. A crushed drive lug will most likely be deformed and show internal fractures. In some cases, severe misalignment can cause side loads to fracture the drive lugs in a similar fashion or appearance.

**PREVENTION:** Maintain proper track tension and track alignment. Inspect track system for mud buildup or signs of stuck material. Check for and replace broken or loose track system parts including drive wheel cleanout bars (when equipped), alignment pins, axles, bearings, adjustment arm bolts, hub bolts, hard bar clamps, swing link components, etc. Replace elastomeric coated wheel components if worn beyond published replacement criteria.

### 5.5.5 Corner Separation (Guide Lugs)

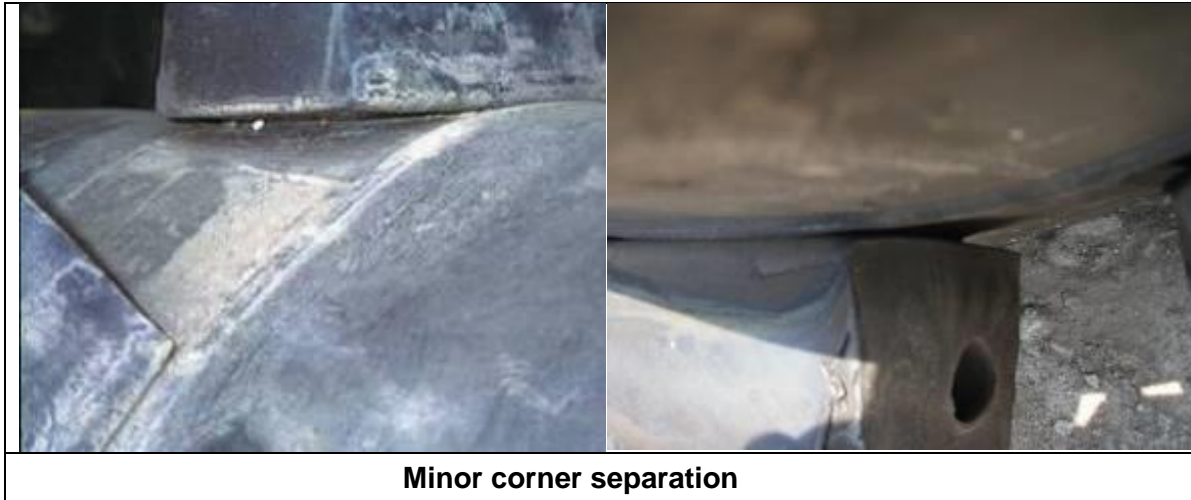

**NON-WARRANTY CAUSE:** Normal manufacturing edge relief and base fatigue due to long term operation.

**APPEARANCE:** Small amounts of separation can occur along guide lug base after substantial operational time. This occurs over time as a result of cyclic loading.

**DISCUSSION:** If the guide lug also shows evidence of contact with the track system frame, see Repeated **Tip Damage**. If enough time elapses, the lug can eventually be lost.

If significant amounts of corner separation are noted, especially with tears into the guide lug material at low hours, the source of the damage is the track system and /or due to side loads or partial untracking events. (See Torn or Jagged Separation).

**PREVENTION:** In normal operation, this cracking or separation should not affect the operation of the track unless it continues to the point of guide lug loss prior to tread wear out.

**NOTE:** Bolt-on guide lugs may be an alternative if a few lugs are lost. See your dealer for more information and more information in this document on bolt-on guide lugs.



## 5.5.6 Reverse Face Wear (Drive Lugs)

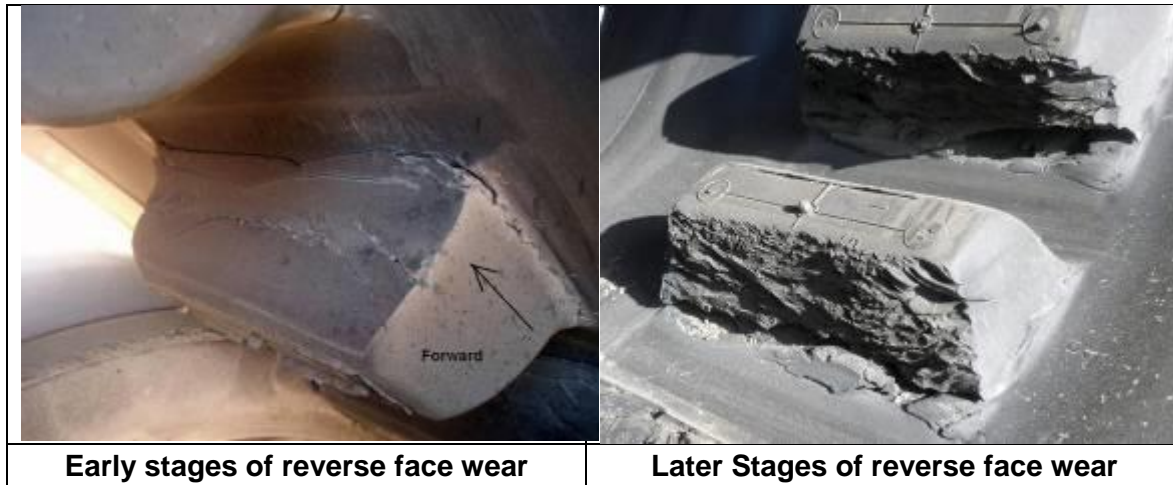

**NON-WARRANTY CAUSE(S):** Mechanical damage from the drive bar scrubbing the reverse (non-power) side of the drive lug. Can be related to very low drawbar loading or extended amounts of roading. This can also be caused by incorrectly sized or worn drive wheels.

**APPEARANCE:** Early stages shown above. More advanced stages will show aggressive erosion or scuffing of the lug. Damage is typically uniform on all lugs and can vary between different machines and even between different tracks on the same machine. Abnormal track vibration can also be a resulting symptom.

**PREVENTION:** Tracks are designed to reduce drive lug face wear in most loading conditions, however worn /undersize drive wheels, or oversize drive wheels with aggressive scrub ratios can still cause face wear during high speed no load operation such as roading, particularly on new tracks operated at high speed prior to the field operation break-in period.

If drive wheels show significant loss in diameter or are unevenly worn inboard to outboard side, or center to the edge of the wheel, then they should be replaced. Oversize wheels due to manufacturing or material build-up can also cause reverse face wear. Wheel scraper should also be used to minimize material build-up on the surface of the wheel.

The ideal operating condition for track lug break-in is **dry and dusty soils**. Dust acts as a dry lubricant to assist in the polishing and break-in phase, and helps minimize early hour break-in scuffing and chunking. Lug damage due to improper break-in is not warrantable. During normal field tillage applications the drive bar will engage in the neutral to positive drive position and not cause reverse face scrubbing action.

## 5.5.7 Ratcheting Damage (Drive Lugs)



**Track / Drive Wheel Ratcheting**

**NON-WARRANTY CAUSE:** Mud Buildup on drive wheel. Low track tension. Severely worn drive lugs that become so narrow as to not be able to carry the torque loads.

**APPEARANCE:** The drive lugs are torn, usually with a jagged separation. Frequently if untracking has occurred more extensive mechanical damage including crushing or scuffing will be seen. A crushed drive lug will most likely be deformed and show internal fractures or splits. In some cases severe misalignment can cause side loads to fracture the drive lugs in a similar fashion or appearance.

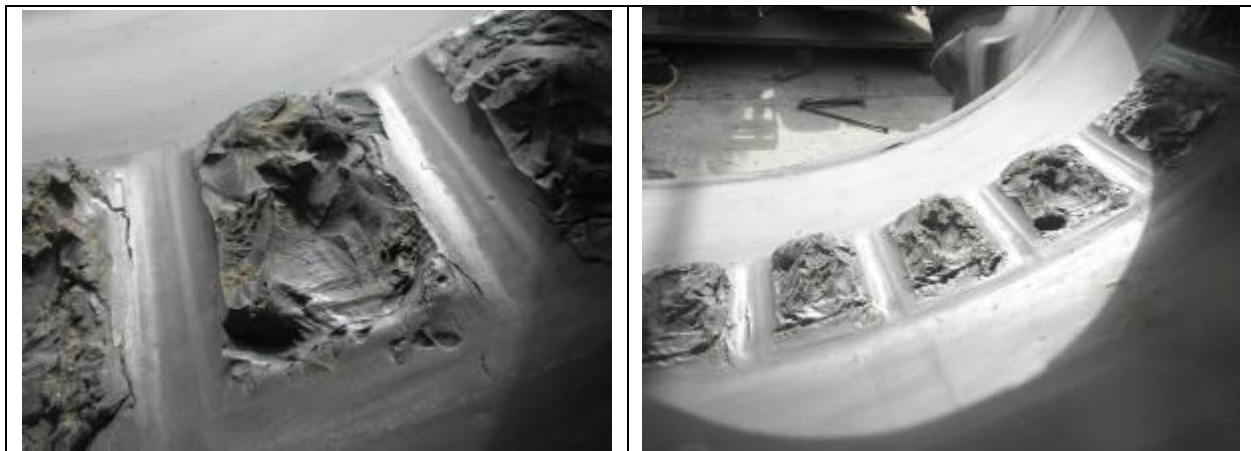

**Final Stages or Ratcheting Loss – All drive lugs have been stripped off the track**

**PREVENTION:** Inspect track system and drive sprocket for mud buildup or signs of stuck foreign material. Drive wheel pockets must remain clear of hard material. Maintain correct track tension and alignment. Also, inspect and replace midrollers with 50% or more rubber missing across the entire width of wheel.

## 5.5.8 Base Cracks (Drive Lugs)



**NON-WARRANTY CAUSE:** Stress cracking due to side loads, misalignment, or ratcheting.

**WARRANTY CAUSE:** Improper cure or contamination during track assembly

**APPEARANCE:** Cracks or minor corner separation can occur near drive lug base after substantial operation time, or sooner if subjected to high side loading, and will occur over time as a result of cyclic loading.

**DISCUSSION:** This cracking will not affect the operation of the track unless separation occurs which causes drive lug loss. This type of problem should not normally be submitted for warranty consideration. If base cracking is seen, monitor the progression (if any), and make sure that alignment is correct and that excessive side loads are not being encountered.

**WARRANTABLE:** If base cracks go across the whole drive lug, turn the corner, and followed by drive lug loss that shows smooth separation in the center of the missing drive lug, then this a warrantable situation

**NON WARRANTABLE:** Straight crack at the base of the lugs and not turning the corners.

## 5.5.9 Reinforcement Layer Exposure (Drive Lugs)



**Drive Lug Reinforcement Layer Exposure**

**NON-WARRANTY CAUSE:** Abrasive soil conditions, improperly sized drive wheel, worn drive wheel, increased/modified power output of machine, sudden shock loading to the drive lugs (i.e. emergency braking or excessive track slippage followed by sudden traction).

**APPEARANCE:** Reinforcement layer becomes visible between drive lugs or in areas on the drive lugs that come into contact with the drive wheel.

**DISCUSSION:** Exposure of the fabric reinforcement layer can occur in the later stages of track life due to drive lug flexing and normal rubber wear from contact with the drive wheel and other abrasive environmental conditions.

If the fabric reinforcement layer is exposed, investigate if it is occurring on other tracks on the same machine. If so, the cause is most likely not manufacturing related.

**NOTE:** In rare circumstances, if the fabric reinforcement layer was not located correctly during production, and this is seen on a new track, it could be possibly a warrantable situation. Contact Camso for clarification as needed.

## 6 Carcass

### 6.1 Typical Wear Patterns / Characteristics

Carcass wear can vary depending on the environment and the application. During track operation, many surface blemishes can appear on the outside and inside carcass surfaces, including; cuts, scrapes, scratches, nicks, surface cracks, slits, etc. In cases where sharp objects are contacted, then varied degrees of minor carcass damage can result. These types of cuts and marks are a normal result of operation in the fields.



## 6.2 Warrantable Conditions

### 6.2.1 Carcass Separation (Traction Lug Side)

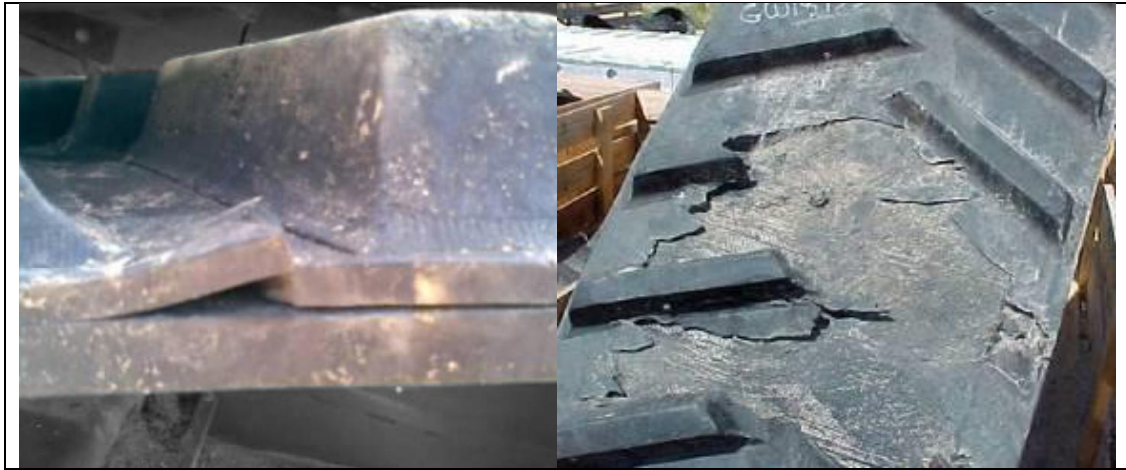

#### Major Separation

**WARRANTY CAUSE:** Contamination or poor manufacturing cure.

**APPEARANCE:** Separation and delamination will generally be in a large area and usually is limited to one layer (between two specific layers of rubber). Because of this, the separation will be smooth. It will likely be concentrated in one area of the track. Many times the separation occurs at clearly defined, non-jagged edges.

**WARRANTY:** YES.

Note that at least one of the following conditions must be met:

- The separation occurs at the main cable layer, causing loss of carcass integrity
- One or more traction lugs or guide lugs are lost or loosened due to this defect
- Clear evidence of smooth separation

#### Minor Separation

**WARRANTY:** NO

In some cases, a minor or partial separation of a small area can occur. A small area is considered a non-disabling or cosmetic defect. However, it is possible that the minor separation could progress to a warrantable condition at some future time. In these cases, file documentation of the condition with Camso and continue to run the track. If a warrantable condition develops at a later date, evidence will be on file to support a warranty replacement at that time.

#### Minor Cracks

**WARRANTY:** NO

Minor cracks can occur. Although this may be related to an issue concerning materials and workmanship, minor cracks are considered non-disabling and of a cosmetic nature and should not be submitted for warranty consideration.

## 6.2.2 Carcass Separation (Localized Section)



**WARRANTY CAUSE:** Contamination or manufacturing cure.

**APPEARANCE:** The track wheel path surface area displays very little damage, with the exception of a localized area. Loose rubber may be present around the margins of the damaged area.

**WARRANTABLE:** In many cases, YES. If the following criteria are met:

- No evidence of drive wheel slippage, seized rolling stock or blistering from excessive heat
- No evidence of carcass damage from sharp material or small stone punctures to other areas of the carcass ID wheel path or the rolling stock.
- Rolling stock is OEM and in good working condition (no midrollers with lost coating), and appropriate midroller option for width of track and application
- Damage is limited to a small section of the track (usually less than 24")
- Remainder of the track internal surface shows normal wear

**DISCUSSION:** This condition may appear similar to a non-warrantable condition in the section titled Carcass **Internal Rubber Separation**. The differences are:

- Damage area is localized versus widespread
- Small wire or rubber exposed only, no main cable exposure
- Operation with elastomeric coated wheels, instead of bare metal wheels

**PREVENTION:** In situations where this is not caused by a defect, if you operate in conditions where build-up or ID chipping or chunking can occur, clean the wheels and UC system periodically and always at the end of the day. If wheel rubber is missing or worn to the point of allowing hard packed soil to stick to it, prompt wheel replacement will help reduce the chance this type of condition may develop.

Use of non-OEM rolling stock of incorrect dimensional and hardness specifications can also cause this type of issue. Also, make sure track tension is correct and the drive wheel is not worn down too much or internal slippage can cause similar damage. Drive wheel slippage usually occurs on both the inboard and outboard sides, and would not be warrantable. If wheel rubber is worn to the point of allowing hard packed soil to stick to it or midrollers have lost rubber, consider prompt wheel replacement in order to prevent more rapid track damage.

### 6.2.3 Distorted Carcass



**WARRANTY CAUSE:** Manufacturing issue

**APPEARANCE:** Under full track tension, a twist or kink is noticed in the carcass of the track. Generally this is also seen as the track is unable to be aligned properly.

**WARRANTY:** YES, if a severe visible kink or twist can be seen and identified in the pictures while the track is properly tensioned and all attempts to align the tracks have failed.

**NON-WARRANTY CAUSE:** Packaging or operational damage



## 6.3 Non-Warrantable Conditions

### 6.3.1 Main Cable Failure (Wheel Path Tear)

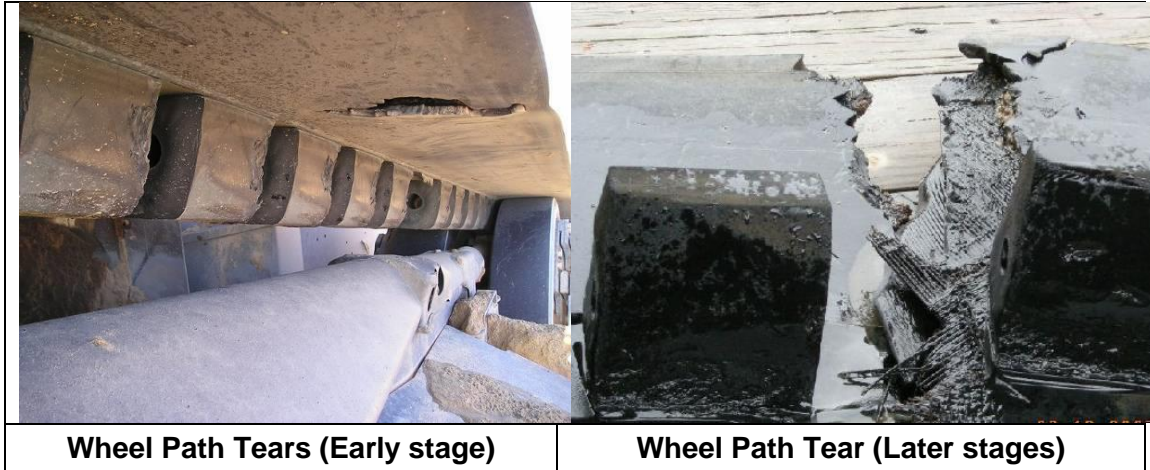

**NON-WARRANTY CAUSE:** Localized over tensioning of the main cable, due to:

- Untracking and resultant localized guide path loading
- Overloading due to a rock or sharp debris
- Over tensioning due to excessive material ingestion, especially during a sharp turn
- Build-up of soil, mud or debris in track system

**APPEARANCE:** In most cases, the damage is through the entire carcass. The tear may be straight across or at an angle. Partial failures can occur on one side of the wheel path (LH photo). After continued operation the track may be torn in half (RH photo). The track may be difficult or impossible to align. In some extreme cases, such as severe packing of debris due to being stuck or buried in material under full load, track may tear across entire width at once.

Since no joints are present in this type of track, in all cases, torn tracks are application related and are not considered warrantable.

**DISCUSSION:** The main cable is a continuous strand wound around the track from one edge to the other. This cable is designed to operate under track tension as well as power transfer, and be able to take localized loads without damage. However, in extreme conditions, it is possible to overload and break a section of the main cable.

In many cases, the main cables are damaged due to punctures to the main cables. Punctures are typically the result of hard foreign objects being run through the undercarriage, such as between the drive wheel or midroller and the track. Punctures to the main cables result in damage to the main cables, weakening the main cable, but also allow dirt and moisture to penetrate the main cables. The dirt and moisture penetration result in the main cables beginning to rust. Over time, the now rusted main cables weaken further due to fatigue and spread across the width of the track. Eventually a tear through the carcass occurs.

**(Continued on next page)**

Pictures below show a track that has ran in the field with the inner rubber layer removed to expose the main cables. Several localized regions of the main cables have seen a puncture which has resulted in the main cables to be damaged and to begin to show signs of rust. Each of these locations is considered to be the beginning of a possible torn main cable.

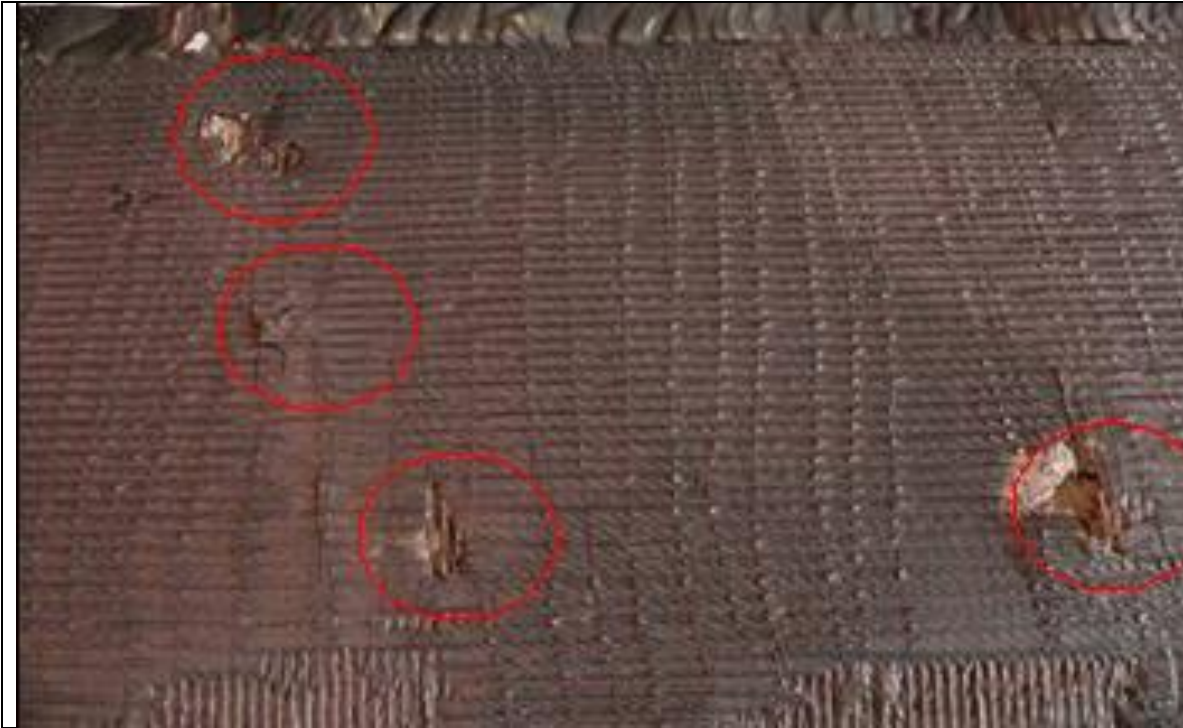

**Internal view of track**  
**Track main cable damage as a result of punctures to the inner surface of the track**

With small tears, the track may continue to run, but overall life will be reduced. Any loose cable should be cut off. If the tear starts to damage any rolling stock, or if alignment can no longer be maintained, then the track should be replaced.

**PREVENTION:** The chances of main cable breakage can be reduced by avoiding situations where material can pack or run through the track system between the wheels and the track. If the machine becomes stuck or buried in soil, do not attempt to drive the machine out of the situation. Clean out the track system first to avoid an over tension condition. Avoid situations where untracking can be an issue as untracking events cause high stresses in the carcass.

Ensure that the right track is being used for the application. Camso has released the 4500 and 6500 Series tracks with improved carcass features to reduce main cable failure events from occurring. Depending on your application, using the correct track carcass (4500 Series or 6500 Series) and tread configuration (low profile, general ag, high roading, scraper) may improve track life. Please refer to the Camso Track Reference Guides for recommended tracks for your application needs.

### 6.3.2 Stubble Wear or Abrasive Damage



**NON-WARRANTY CAUSE:** Track operation on sharp, woody crop stubble.

**APPEARANCE:** The tread bars and the carcass sections between them will usually show chipping damage down a narrow path of the track (LH photo). The chipping may eventually expose the OD alignment layers (RH photo). The damage path will correspond with the location of the crop stubble. This will vary depending on the implement and operator.

**DISCUSSION:** This type of damage is most prevalent in very woody crop stubble, such as sunflower, pineapple, or sugar cane, but can also occur in certain conditions in corn and bean stubble as well.

**PREVENTION:** Run between the crop stubble during the primary tillage pass if possible. When harvesting, cut crop closer to the ground to minimize the stubble height. Use of stalk stompers can minimize this type of damage.

### 6.3.3 Internal or External Carcass Damage (Chunk, Cracks)



**NON-WARRANTY CAUSE:** Localized loading of carcass caused by:

- Operation in narrow beds with improper width tracks (edge cracking)
- Operation of track in the furrow, causing debris ingestion and severe bending
- Untracking to inside of machine on frame or guards (mechanical damage)
- Operation in conditions where material builds up on the elastomeric coated wheels
- Operation in severe ground and material conditions (i.e. construction)
- Operation with rocks/material stuck or embedded in the undercarriage wheels

**APPEARANCE:** This type of failure is most frequently on the internal carcass under or at the edge of the wheel path. Material is pinched between the wheels and the track rubber, or where the edge of the furrow is folding the track and causing material to stay in the track system.

**DISCUSSION:** Most of the time this type of damage is non-disabling, and allows the track to continue to be operational without loss in life. In some cases (mechanical damage), a loose end of a main cable may become exposed. This end should be cut off to minimize additional potential damage if it caught on the track system and pull further out of the track.

**PREVENTION:** If ID damage is a potential concern, use tracks designed with inside reinforcement to minimize the damage.

Ensure that the right track is being used for the application. Depending on your application, using the correct track carcass (4500 Series or 6500 Series) and tread configuration (low profile, general ag, high roading, scraper) may improve track life. Please refer to the Camso Track Reference Guides for recommended tracks for your application needs.

### 6.3.4 Internal Splits in the Carcass

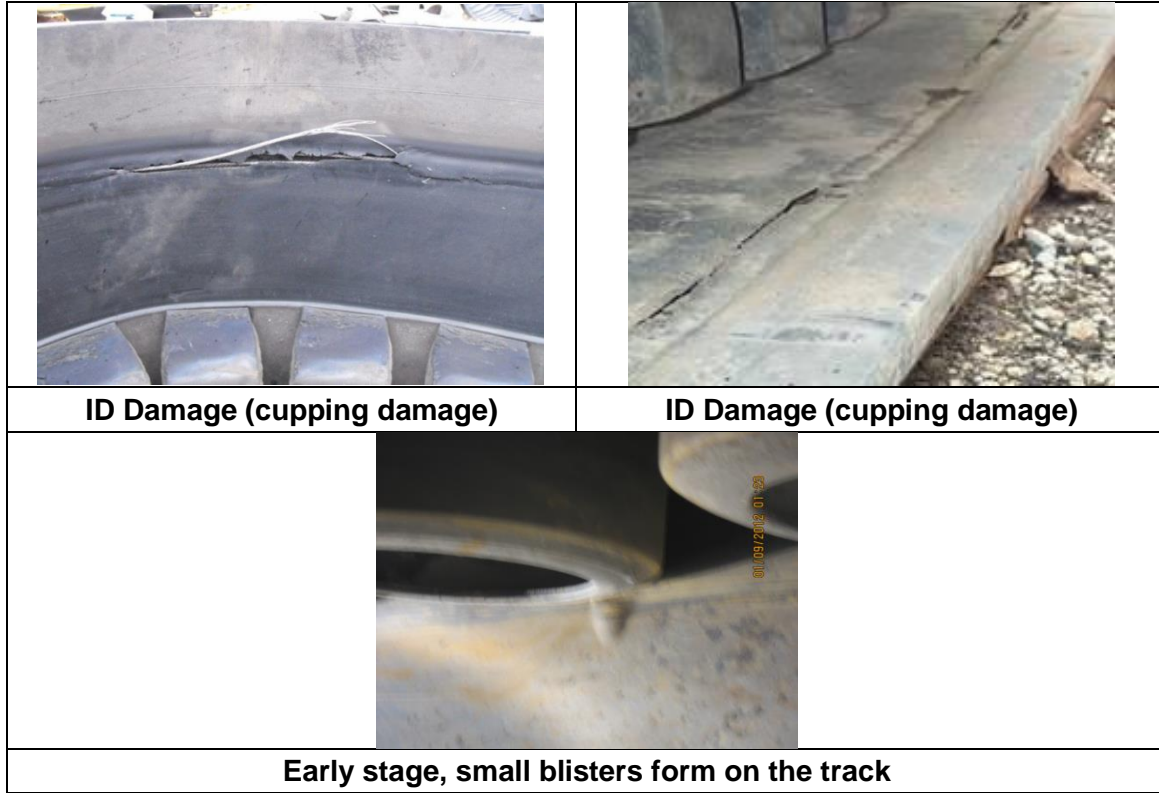

**NON-WARRANTY CAUSE:** Localized loading of carcass caused by:

- Operation of tracks that are much wider than undercarriage wheels (high load concentrations right next to the wheel path due to severe track flexing)
- Operation in narrow beds with improper width tracks (edge cracking)
- Operation of track in the furrow, causing debris ingestion and severe bending
- Operation in severe ground and material conditions (i.e. construction)

**APPEARANCE:** This type of failure is most frequently on the internal carcass at the edge of the wheel path. Small blisters may be seen in the carcass near the edge of the wheel path. If track continues to run, the split will open further, exposing the main cables. In extreme cases, the main cable can come out of the carcass resulting in damage to undercarriage components.

**DISCUSSION:** Tracks can continue to be used if in the early stages. Changing to the correct width wheels may improve track life if installed at the early stages. Track should be replaced at the later stages to prevent additional downtime and damage to other components due to the cable unravelling from inside the track.

**PREVENTION:** Use the correct width tracks for the application. Use the correct width wheels for the tracks being used. Wheel width recommendations for particular width tracks can be found in the Camso Track Reference Guides.

### 6.3.5 Wheel Path Separation—Friction Drive (Due to Material Buildup)

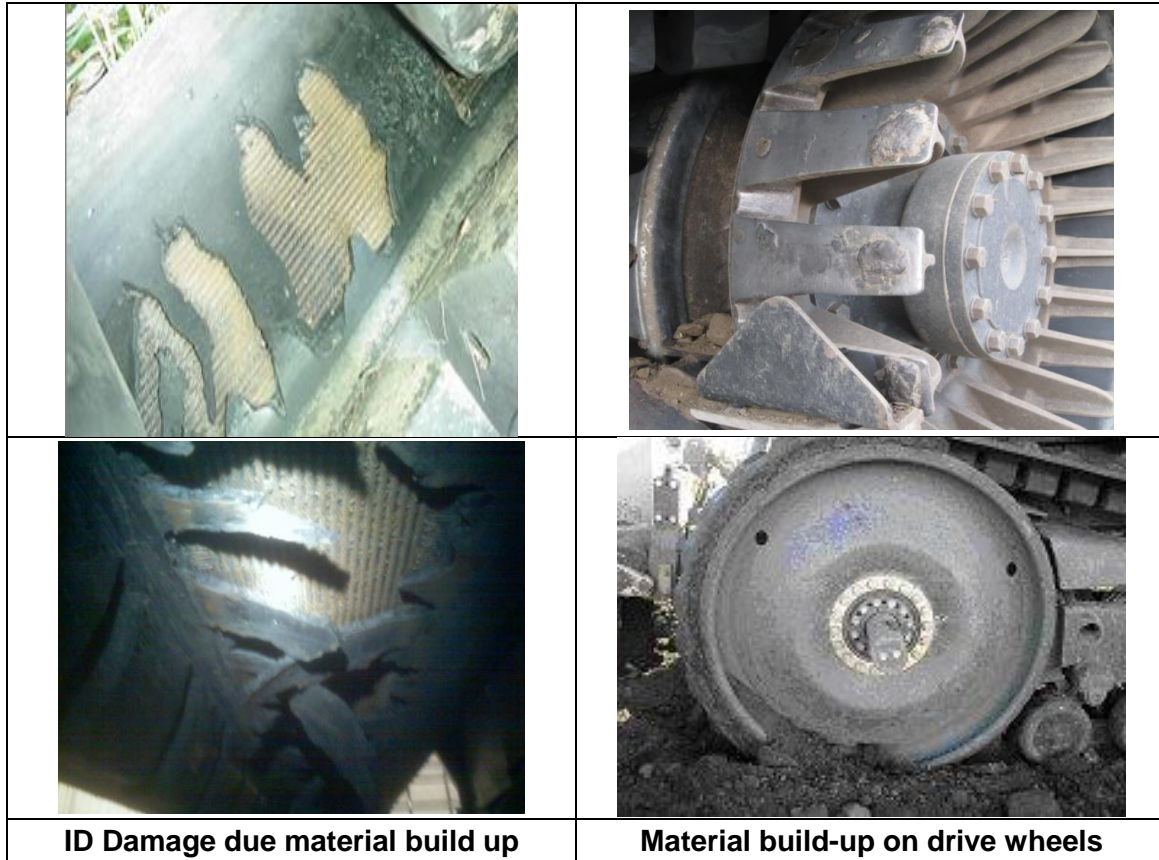

**NON-WARRANTY CAUSE:** Material building up on drive wheels, idlers, midrollers and/or operation with non-elastomeric coated wheels causing blistering or grooving of the inside track surface, overloading due to failed midrollers, excessive heat generation from extended transport time, or spinning of drive wheel inside the track.

**APPEARANCE:** Rubber detachment around the entire circumference of the track. The separation width will be approximately equal to the drive wheel width. The track inside surface may initially show blistering or grooving of the rubber. Later stages will show inside surface rubber flaps, separating down to the inner reinforcement layer, or the track main cables.

**DISCUSSION:** Operation with steel (non rubber coated) drive wheels, idlers, or midrollers is the primary cause for this failure mode. Build-up of dirt or ice on wheels repeatedly can cause blistering or grooving of the inside track surface. After sufficient cycles, the entire inside surface can bubble up and separate. Blistering can also be caused by operating with several failed midrollers, causing the remaining midrollers to concentrate a higher load on the inside of the track. The damage is usually limited to the path of the undercarriage wheels and does not show signs of separation outside of the wheelpath.

**PREVENTION:** Check drive wheels, midrollers, and idlers frequently for a damaged or missing rubber coating. On machines with steel drive wheels, ensure drive wheel scrapers are installed and properly adjusted to keep the drive wheels as clean as possible. If wheel rubber is worn to the point of allowing hard packed soil to stick to it, or midrollers have lost rubber, always make a prompt wheel replacement in order to prevent track damage.

### 6.3.6 Wheel Path Separation—Positive Drive (Due to Material Buildup)

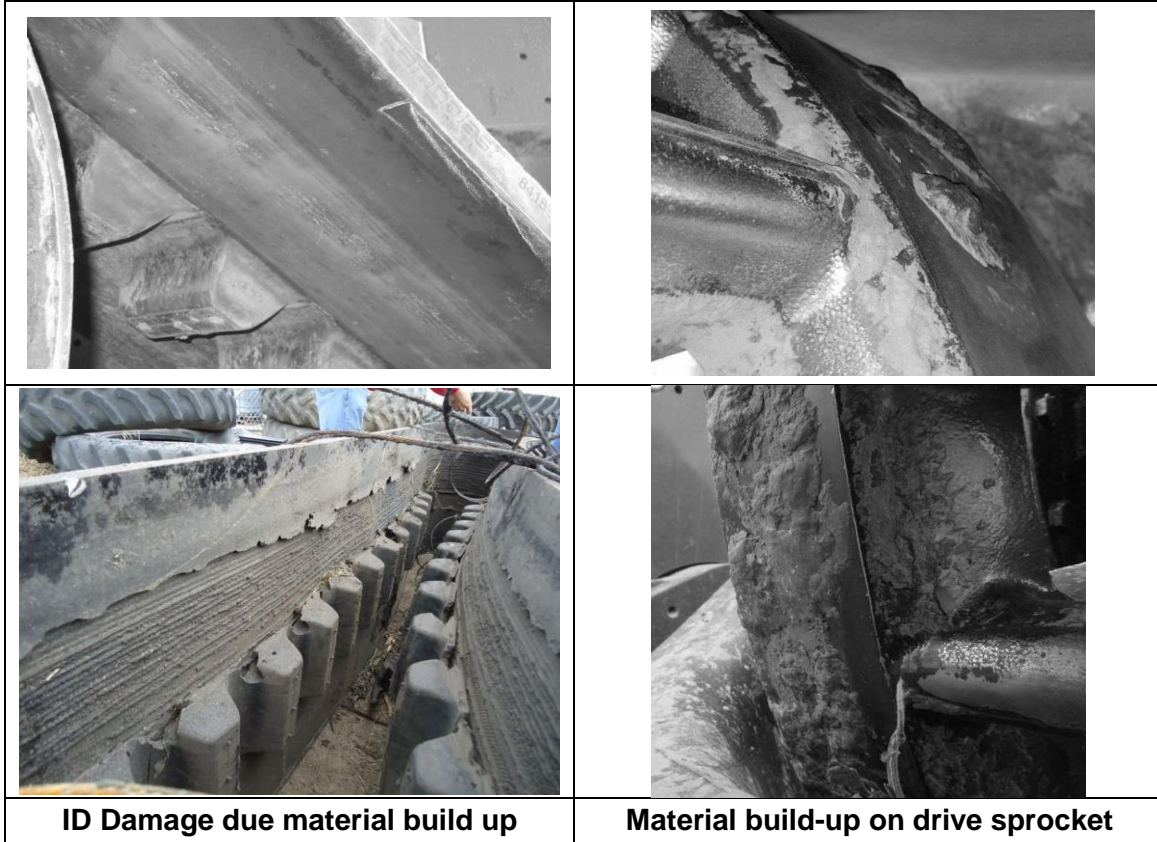

**NON-WARRANTY CAUSE:** Material building up on drive wheels, idlers, midrollers and/or operation with non-elastomeric coated wheels causing blistering or grooving of the inside track surface, overloading due to failed midrollers, excessive heat generation from extended transport time, or spinning of drive wheel inside the track.

**APPEARANCE:** Rubber detachment around the entire circumference of the track. The separation width will be approximately equal to the drive wheel width. The track inside surface may initially show blistering or grooving of the rubber. Later stages will show inside surface rubber flaps, separating down to the inner reinforcement layer, or the track main cables.

**DISCUSSION:** Operation with steel (non rubber coated) drive wheels, idlers, or midrollers is the primary cause for this failure mode. Build-up of dirt or ice on wheels repeatedly can cause blistering or grooving of the inside track surface. After sufficient cycles, the entire inside surface can bubble up and separate. Blistering can also be caused by operating with several failed midrollers, causing the remaining midrollers to concentrate a higher load on the inside of the track. The damage is usually limited to the path of the undercarriage wheels and does not show signs of separation outside of the wheelpath.

**PREVENTION:** Check drive wheels, midrollers, and idlers frequently for a damaged or missing rubber coating. On machines with steel drive wheels, ensure drive wheel scrapers (if available) are installed and properly adjusted to keep the drive wheels as clean as possible. If wheel rubber is worn to the point of allowing hard packed soil to stick to it, or midrollers have lost rubber, always make a prompt wheel replacement in order to prevent track damage.

### 6.3.7 Mechanical Edge Damage

	
	
<p style="text-align: center;"><b>DAMAGE CAUSE</b></p>	<p style="text-align: center;"><b>DAMAGE EFFECT</b></p>

**NON-WARRANTY CAUSE:** Mechanical contact with external objects such as an implement, posts, blades, posts, culverts, machine frame, etc.

**APPEARANCE:** The edge of the track will be jagged, and can either be on the inboard side (from partial or full untracking events) or if on the outboard side (implement or other external contact). The track may have either single or multiple tread bars damaged on either side of the main damaged area. Tread bars and carcass will show ragged tears and cables may or may not be exposed. If mechanical damage allows the main cable to be exposed, the failure may also appear to be similar to section **Exposed or Loose Main Cables**.

**DISCUSSION:** This type of damage usually does not disable a track, and it should continue to run. Overall track life may or may not be significantly reduced.

**PREVENTION:** When operating the machine, avoid edge contact with any sharp objects such as implement tongues, wings, disk blades, etc. Maintain proper tension and use correct operational techniques to avoid partial or full untracking. Use care when roading or transporting machine to not catch track edges on any lowboy sharp edges. Maintain proper tension and operate sensibly to avoid partial or full untracking events.



### 6.3.8 Exposed or Loose Main Cable



**NON-WARRANTY CAUSE:** Inside rubber cracks or splits, or mechanical damage, causing exposed cable.

**APPEARANCE:** The main cable starts approximately 1” from the edge. If the damage allows the termination of the main cable to be exposed, it may work out of the carcass.

**DISCUSSION:** Main cable ends may be exposed as a result of the following conditions:

- Damaged midrollers
- Turning into an implement
- Mechanical damage (during transport on a lowboy or loading/unloading)
- Secondary result of edge damage in furrow or bed work
- Untracking (on inboard side contacting the machine frame)

**PREVENTION:** Avoid contacting the track with any sharp edges by turning into an implement tongue or wing. Use care when transporting machine to not catch tracks on any trailer sharp edges. Maintain proper tension and operate sensibly to avoid partial or full untracking events.

**IMPORTANT:** If main cables are protruding from the track, immediately trim cable to prevent a whipping effect that can lengthen an exposed cable. Provided that the cable protrudes near the edge of the track, performance of track will not be affected and track may continue to run. Monitor the condition and trim cable as needed to keep elastomeric coated component damage to a minimum and to extend track life. If enough cable is lost or the area moves into the wheel path, then the track may need to be replaced to avoid possible wheel contingent damage and because alignment may no longer be able to be achieved.

### 6.3.9 Carcass Ribbon Separation



**NON-WARRANTY CAUSE:** Hard material buildup on drive wheels or idler wheels. Operation with drive lugs without full track width support on the drive wheel. Frequently this failure mode is a secondary failure as a result of a main cable / wheelpath tear.

**APPEARANCE:** Main cable separation underneath the drive or guide lugs in large sections of the track.

**DISCUSSION:** Dirt and materials can build-up can bridge in the center of the idlers or drive wheels. Also, material can build up in the drive wheel drive lug pockets and increase main cable loading under the lugs more than normal. Sufficient build-up will raise the center of the track as the lugs ride on top of the material. This condition can over tension the center of the carcass causing the center cables to pull loose from the carcass. Another indicator is scuff marks or wear on top of the guide lugs.

If a track is operated for an extended period of time with a wheel path tear, it is very likely that such damage will occur. If you see this type of damage on a track, may sure to always look for the original primary cause which may be a torn track.

**PREVENTION:** If you operate in conditions where hard material build-up occurs, check / clean this area as needed to prevent bridging in the center of the wheels.

### 6.3.10 Wheel Path Wear (Internal surface)

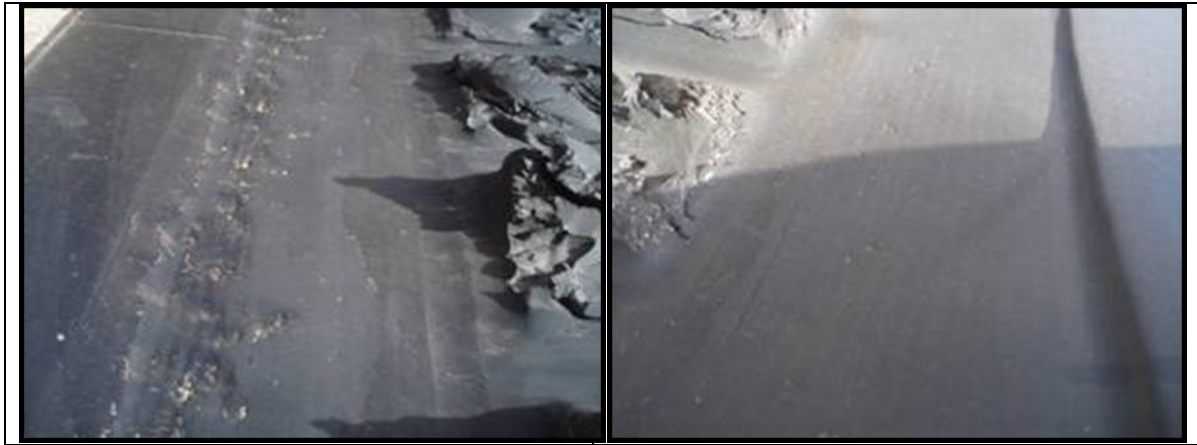

**NON-WARRANTY CAUSE:** Normal wear. In some severe cases, drive wheel to track slippage, due to loss of tension and resulting in drive lug ratcheting, material buildup on drive wheel, or lockup of midroller inside the track.

**APPEARANCE:** This type of damage appears in the inside surface of the track as grooved or planed off, as opposed to sheet separation. Most or all of the ID rubber is worn off rather than broke off the inside of the track. The wear will be in uniform circumferential grooves around the track. Usually, either a drive wheel or a midroller may also show significant wear. If due to a lock up on a midroller, this midroller will show a flat/worn section or may not be freely turning.

**PREVENTION:** Monitor midrollers for signs of lockup due to rocks or mechanical damage. Always maintain correct track tension. When operating in adverse environments, be aware of possible slippage between the track and wheels. If slippage inside the track occurs, operate in a manner to avoid continuous spinning inside track for an extended time in order to minimize damage. Monitor drive wheel scraper wear and adjust/replace as necessary.

### 6.3.11 Loss of alignment



**NON-WARRANTY CAUSE:** Broken steel plies within the carcass of the track.

**APPEARANCE:** Typically the outside of the track show little to no signs of an issue with the exception of the guide lugs showing wear. Typically the track has been operating for several hundred hours without any alignment issues and then at some point, the track is no longer able to be aligned.

**DISCUSSION:** Typically this failure mode is related to applications with very heavy machine weight, such scraper applications and harvesters. Over time, the steel plies fatigue and break next to the wheel path due to the high loads. This results in the track to be unalignable. If this issue is observed, track replacement is necessary to prevent additional damage to other components.

### 6.3.12 Track Noise (Snapping or clicking)

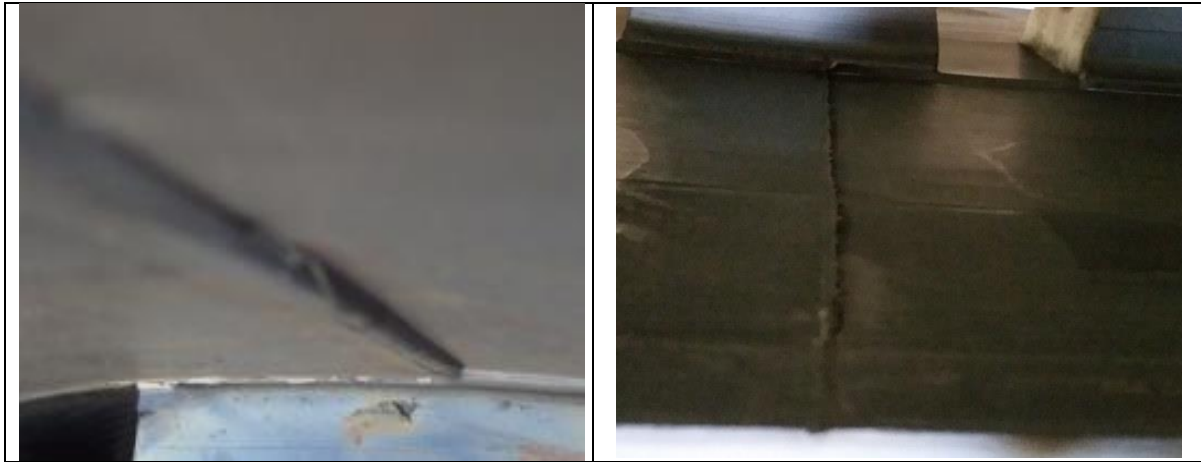







**NON-WARRANTY CAUSE:** Normal rubber flash from track assembly process

**APPEARANCE:** Some minor excess rubber flash may remain on new tracks. In some cases, a noise is caused as the midrollers travel across this rubber flash. The sound is similar to a clicking noise or snapping sound as each of the midroller go across the rubber flash.

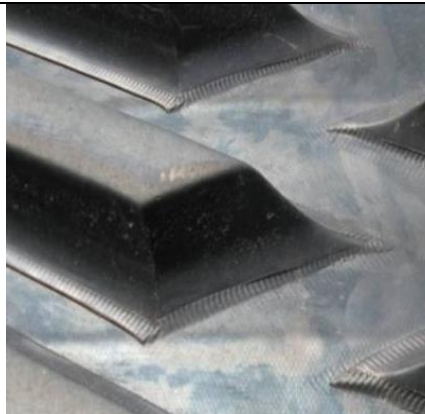
**DISCUSSION:** Normally the rubber flash wears off over time as the track is used. If the noise is concerning, the rubber flash can be removed using a sharp flat knife or by using a grinder with a sanding flap disk installed to smooth out the rubber flash.

## 7 Cosmetic Defects

### 7.1 Tread bar

		
<b>Varying tread bar stitching</b>	<b>Alternate stitch appearance</b>	<b>Mold Lines</b>
		
<b>Small notch in edge of tread bars</b>	<b>Small depressions or lumps in the tread bars</b>	<b>Handling mark on side of tread bar</b>

**NON-WARRANTY CAUSE:** Normal manufacturing process-due to minor manufacturing defects, environment or minor mechanical damage.

**APPEARANCE:** See above photos for some general examples.

**DISCUSSION:** Cosmetic defects do not affect the overall track life and should not be submitted for warranty consideration unless it is determined that a significant reduction in overall track life will result.

**PREVENTION:** No change in operation is needed. In rare cases, the cosmetic issue may signal the early stages of another problem. If unusual cosmetic defects are seen, other than ones noted above, note and document the defect (if possible with photos and current hours). Then monitor the area of concern to see if a more serious condition develops.

## 7.2 Drive Lug

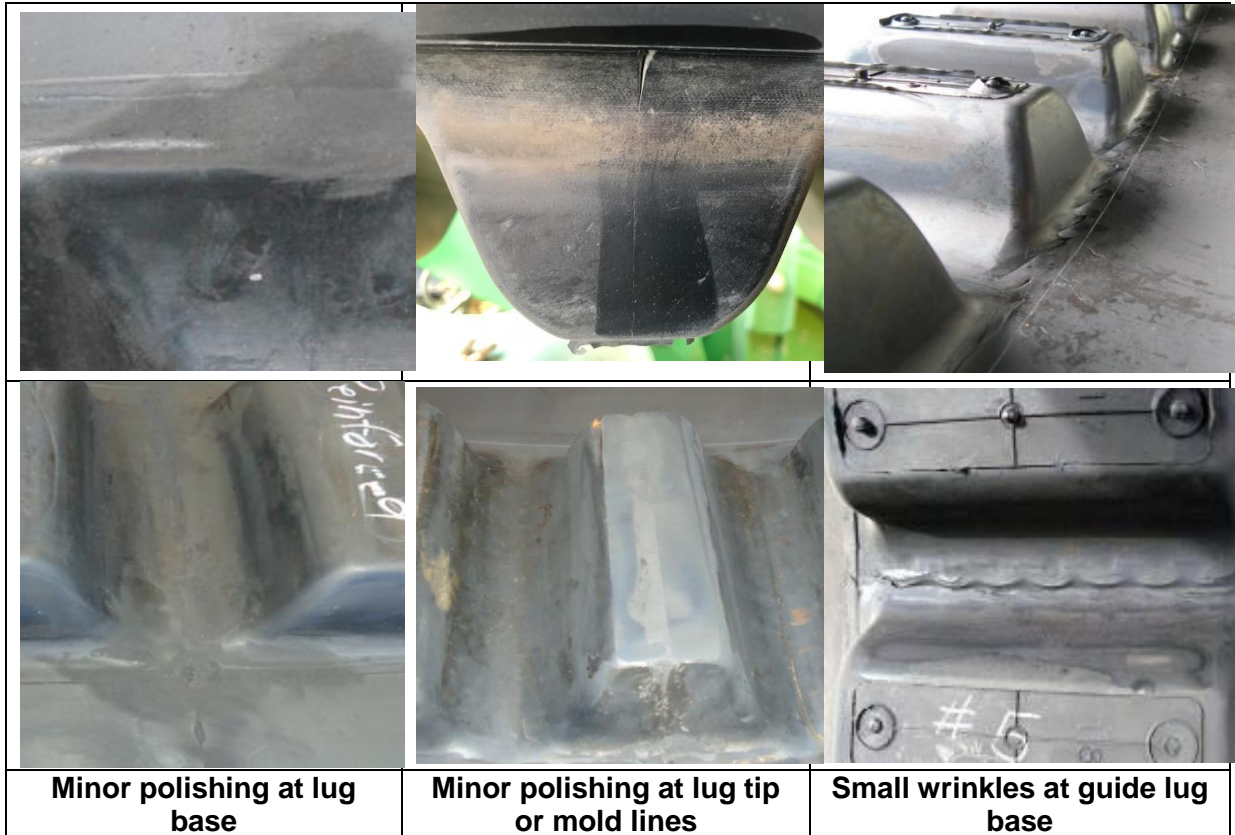

**NON-WARRANTY CAUSE:** Normal manufacturing process-due to minor manufacturing defects, environment or minor mechanical damage.

**APPEARANCE:** See above photos for some general examples.

**DISCUSSION:** Cosmetic defects do not affect the overall track life and should not be submitted for warranty consideration unless it is determined that a significant reduction in overall track life will result.

**PREVENTION:** No change in operation is needed. In rare cases, the cosmetic issue may signal the early stages of another problem. If unusual cosmetic defects are seen, other than ones noted above, note and document the defect (if possible with photos and current hours). Then monitor the area of concern to see if a more serious condition develops.

### 7.3 Guide Lug



**NON-WARRANTY CAUSE:** Normal manufacturing process-due to minor manufacturing defects, environment or minor mechanical damage.





**APPEARANCE:** See above photos for some general examples.

**DISCUSSION:** Cosmetic defects do not affect the overall track life and should not be submitted for warranty consideration unless it is determined that a significant reduction in overall track life will result.

**PREVENTION:** No change in operation is needed. In rare cases, the cosmetic issue may signal the early stages of another problem. If unusual cosmetic defects are seen, other than ones noted above, note and document the defect (if possible with photos and current hours). Then monitor the area of concern to see if a more serious condition develops.

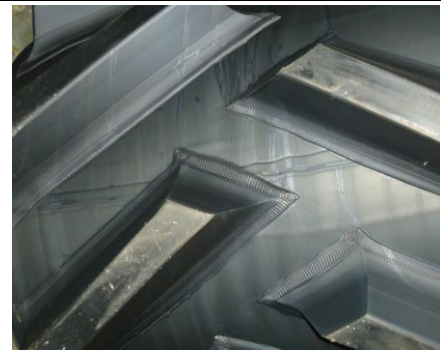

## 7.4 Carcass

		
<b>Small surface grooves</b>	<b>Small surface wrinkles</b>	<b>Small surface imperfections</b>
		
<b>Slight irregularity on outside surface of track</b>	<b>Small depressions near the branding strip</b>	<b>Slight uneven track surface</b>

**NON-WARRANTY CAUSE:** Normal manufacturing process-due to minor manufacturing defects, environment or minor mechanical damage.

**APPEARANCE:** See above photos for some general examples.

**DISCUSSION:** Cosmetic defects do not affect the overall track life and should not be submitted for warranty consideration unless it is determined that a significant reduction in overall track life will result.

**PREVENTION:** No change in operation is needed. In rare cases, the cosmetic issue may signal the early stages of another problem. If unusual cosmetic defects are seen, other than ones noted above, note and document the defect (if possible with photos and current hours). Then monitor the area of concern to see if a more serious condition develops.

# 8 Treadbar Wear Estimation Chart

Tread Height (in)	Tread Height (mm)	New Track Tread Height														
		3" (76 mm)	2.9" (74 mm)	2.8" (71 mm)	2.7" (69 mm)	2.6" (66 mm)	2.5" (64 mm)	2.3" (58 mm)	2.2" (56 mm)	2.1" (53 mm)	2" (51 mm)	1.6" (41 mm)	1.5" (38 mm)	1.0" (25 mm)		
3.0	76	0%	0%													
2.9	74	8%	4%													
2.8	71	8%	4%	0%												
2.7	69	12%	8%	4%	0%											
2.6	66	16%	13%	9%	5%	0%										
2.5	64	20%	17%	13%	9%	5%	0%									
2.4	61	24%	21%	17%	14%	10%	5%									
2.3	58	28%	25%	22%	18%	14%	10%	5%								
2.2	56	32%	29%	26%	23%	19%	15%	10%	6%	0%						
2.1	53	36%	33%	30%	27%	24%	20%	17%	12%	6%	0%					
2	51	40%	38%	35%	32%	29%	25%	22%	19%	13%	6%	0%				
1.9	48	44%	42%	39%	36%	33%	30%	28%	24%	18%	13%	7%				
1.8	46	48%	46%	43%	41%	38%	35%	33%	29%	24%	19%	13%				
1.7	43	52%	50%	48%	45%	43%	40%	38%	33%	29%	25%	20%				
1.6	41	56%	54%	52%	50%	48%	45%	43%	39%	35%	31%	27%	0%			
1.5	38	60%	58%	57%	55%	52%	50%	50%	44%	41%	38%	33%	0%			
1.4	36	64%	63%	61%	59%	57%	55%	55%	50%	47%	44%	40%	0%			
1.3	33	68%	67%	65%	64%	62%	60%	60%	56%	53%	50%	47%	0%			
1.2	30	72%	71%	70%	68%	67%	65%	65%	59%	56%	53%	50%	0%			
1.1	28	76%	75%	74%	73%	71%	70%	67%	61%	59%	56%	53%	0%			
1	25	80%	79%	78%	77%	76%	75%	72%	65%	63%	60%	57%	0%			
0.9	23	84%	83%	83%	82%	81%	80%	78%	71%	69%	66%	63%	0%			
0.8	20	88%	88%	87%	86%	86%	85%	83%	76%	75%	73%	70%	0%			
0.7	18	92%	92%	91%	91%	90%	90%	89%	82%	81%	80%	78%	0%			
0.6	15	96%	96%	96%	95%	95%	95%	94%	88%	88%	87%	85%	0%			
0.5	13	100%	100%	100%	100%	100%	100%	100%	94%	94%	94%	93%	0%			
0.4	10	104%	104%	104%	105%	105%	105%	106%	100%	100%	100%	100%	0%			
0.3	8	108%	108%	109%	109%	110%	110%	111%	106%	106%	106%	107%	0%			
0.2	5	112%	113%	113%	114%	114%	115%	117%	111%	112%	113%	113%	0%			
0.1	3	116%	117%	117%	118%	119%	120%	122%	118%	118%	119%	120%	0%			
0.0	0	120%	121%	122%	123%	124%	125%	128%	124%	124%	125%	127%	0%			
Challenger MT700/MT800--6500 & 5500 Series																
John Deere 9000T--5500 Series John Deere 9RT--6500 & 5500 Series																
John Deere 8RT--6500 & 5500 Series John Deere 9000T--3500 Series																
Challenger MT700/MT800--6500 & 5500 Series Challenger MT700/MT800--4500 & 3500 Series																
Challenger Rowcrop--3500 & 4500 Series Challenger Tillage--3500 & 4500 Series John Deere 8000T--3500 & 5500 Series John Deere 8RT--3500 & 4500 Series John Deere 9RT--3500 & 4500 Series Camso CTS Combines--3500 Series																
Claas Combines and Harvesters--3500 Series																
John Deere 9RT--6500 & 5500 Series																
Challenger MT800--6500 & 5500 Series																
Challenger Rowcrop--2500 Series Challenger Tillage--2500 Series John Deere 8000T--2500 Series																
Case IH STX--3500, 5500, 6500 Series Case IH 9300--3500, 5500, 6500 Series Case IH Combine--3500 Series New Holland Combine--3500 Series ATI/New Holland T9 SmartTrax--3500 Series John Deere 9000T-2500 Series John Deere 9RX Wide--3500 & 6500 Series Camso CTS Tractors--3500 Series																
Challenger Tillage--3500 Series Case IH Steiger Quadtrac--3500, 5500, 6500 Series Case IH 9300 Quadtrac--3500, 5500, 6500 Series Case IH Steiger Rowtrac--3500 Series Case IH Magnum Rowtrac--3500 Series New Holland Genesis Smart Trax--3500 Series John Deere 9RX Scraper--6500 Series John Deere 9RX Narrow--6500 Series																
Challenger MT700--4500 & 3500 Series																
Camso Flexhaul Camso TTS																

## 9 Elastomeric Coated Wheels

### 9.1 Wear Characteristics of Coated Wheels

#### Drive Wheels and Idlers

Drive wheels and idler wheels are not generally considered wear items, and should last to major overhaul in most applications. Any significant wear should be noted especially if it develops quickly, as this may indicate a track system problem.

#### Friction Drive Drive Wheels

Drive wheel tractive effort on a friction drive system relies on the drive wheel rubber groove edges to wipe mud and moisture out of the track. Anytime the groove leading edge is damaged or rounded, or if proper track tension is not maintained, the effectiveness of the drive wheel at “grabbing” the track is diminished and internal slip can occur.



#### Positive Drive Drive Wheels

Drive wheel traction on a positive drive system relies on the proper engagement of the drive lugs into the drive wheel sprocket. Any time this drive wheel is packed with material, damaged, worn, or the track is not tensioned under the proper specifications, damage to the drive lugs can result.



## **Midrollers**

Midrollers carry the majority of the machine weight when the machine is properly balanced. Midrollers are generally considered wear items and require replacement in a similar timeframe to that of the track. Midrollers do not typically encounter failures unless due to excess speed, weight, loading, or due to mechanical damage.

Major factors influencing midroller life include:

- Total load (narrower midroller have higher unit loading)
- Extent of abrasive conditions causing physical damage
- Peak temperatures seen during operation and extended roading, or from misalignment
- Material cascading into track system



**Typical Midroller Edge Wear (Mid life and late life)**

### **Typical Wear Patterns**

Midrollers display small nicks and chunks, small sections with material loss, rock punctures, and separation at the edges. Midrollers will continue to perform their intended function with this type of damage and do not need to be replaced until they meet replacement criteria, discussed later in this section.

To maximize life, minimize operation in rocky or abrasive soil if possible. Consider ways to reduce recirculation of material on top of the midrollers and through the track system. Remove embedded rocks or debris from wheel coating to prevent further penetration and separation.

**The primary reason for midroller failures is HEAT. This heat can be from misalignment, from extended roading, from high ambient temperatures, or from high ballasted loads. Note that the wider the midroller width, the more heat it can dissipate, and the lower the unit loading. Always use the widest midroller available for the given track being used.**

During normal operation, midrollers typically see coating edge wear. Significant wear may be evident, but the midrollers will still perform as intended and have considerable life remaining. Do not replace a midroller unless they meet the replacement criteria listed below.

## 9.2 Midroller Replacement Criteria

Operate midrollers until such time that one of the following conditions occurs:

1. More than 1/3 of the midroller coating is missing all the way around
2. Any area where midroller coating loss extends across entire roller width
3. Midroller no longer turns freely
4. Midroller face begins to build-up with dirt due to lack of coating thickness
5. Any flat spots are visible which may indicate wheel stopped turning

Outer edge wear and missing coating is common on midrollers and do not require replacement unless they meet one of the above criteria.



**NOTE: REPLACE MIDROLLERS IN SETS ON SAME AXLE IF SIGNIFICANT WEAR IS EVIDENT.** It is not advisable to pair a worn midroller on the same axle as a new midroller, or overloading of the opposite side midroller may occur. Opposite side replacement is non warrantable unless the midroller meets replacement criteria.

## 9.3 Warrantable Conditions

### 9.3.1 Smooth Separation – (Drive wheel)



**WARRANTY CAUSE:** Poor manufacturing process control

**APPEARANCE:** Sections of the drive wheel or idler coating are torn or chunked away.

**WARRANTY:** In some cases, YES. If a manufacturing issue exists, this condition will be apparent early in the wheels' life (less than 1000 hours).

If a warrantable condition exists if there is clean separation of large sections of the coating from the wheel

Request a pre-approval before considering replacement due to suspected warranty causes. This type of issue can be caused by either warrantable or non-warrantable causes.

**NON WARRANTY CAUSE:** Abrasive soil conditions or mechanical damage

**NON-WARRANTABLE CONDITION:** If this type of issue appears later in life (> 1000 hours for example), then a combination of factors could be contributing to the failure

- Mechanical damage
- High heat input (misaligned tracks)
- Unbalanced machine operation with extended roading (heavy vertical loads)
- Abrasive or sharp soil conditions

**PREVENTION:** Avoid conditions in which the abrasive soil can get into the track. Minimize the amount of spot turning, and avoid multiple passes in the same cut with scraper pan applications, which can cascade material into the track.

### 9.3.2 Smooth Separation (Idler / Midroller)

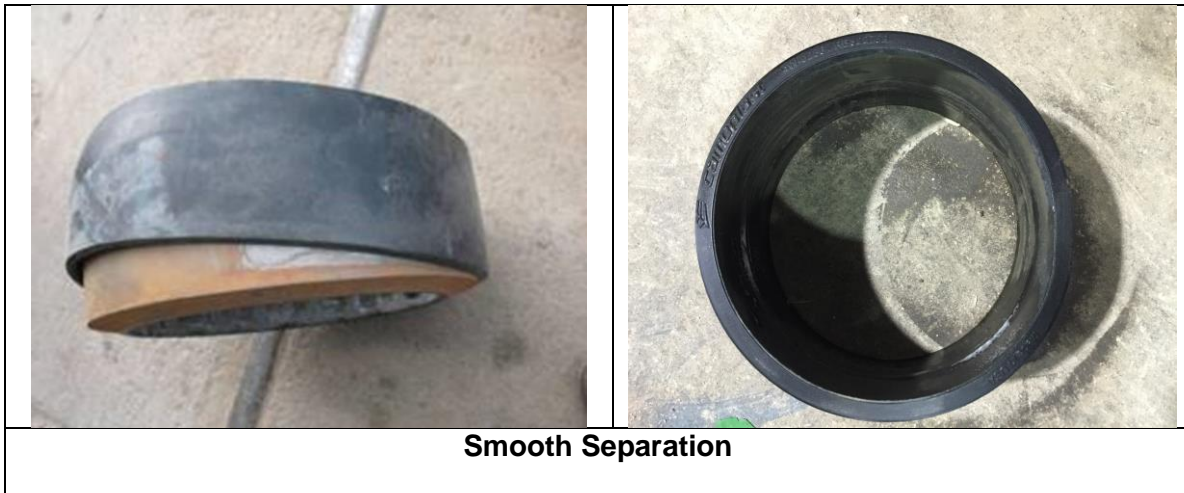

**WARRANTY CAUSE:** Poor adhesion to steel or casting

**APPEARANCE:** Coating separates cleanly from the idler / midroller on the edges AWAY from the guide lugs, or coating comes off the wheel cleanly in one piece with almost no adhesion.

**WARRANTY:** YES. The following conditions should be present to allow for warranty replacement:

1. Track is confirmed to have been properly aligned (no excess heat input)
2. Separation is smooth, is on the outside edge and/or entire coating ring was lost
3. Idler / midroller meets replacement criteria listed in prior section – idlers and midrollers are not claimable if they do not meet replacement criteria

If there is evidence of adhesion on the wheel, or if the wheel coating material has jagged separated from the guide lug side, then please see “**Coating separation – Excessive Heating**” in the non-warrantable section.

### 9.3.3 Pitting or Chunking (Drive wheels)



#### MAJOR PITTING

**WARRANTY CAUSE:** Poor manufacturing / process control

**APPEARANCE:** Sections of the drive wheel or idler coating are torn or chunked away.

**WARRANTY:** In many cases, YES. If a manufacturing issue exists, this condition will be apparent early in the service life. A warrantable condition exists if one or more of the following conditions are also seen:

- All non-warrantable causes are eliminated (debris, misalignment, etc)
- Defined areas appear to be soft, sticky, delaminated, brittle, etc.

Request a pre-approval before considering replacement due to suspected warranty causes. This type of issue may require some additional investigation.

#### MINOR PITTING

**NON-WARRANTY CAUSE:** Abrasive soil conditions or mechanical damage.

**DISCUSSION:** The appearance of chunking or damage near the guide lugs can be caused by track misalignment or derailing. General rubber chunking in the drive wheels and idlers can also be due to the soil conditions, and how much sharp material passes through the track system. If defined areas appear to have unusual brittleness or softness of the coating material, further investigation may be needed to determine if this is a warrantable situation.

**PREVENTION:** Avoid conditions in which the abrasive soil can get into the track. Minimize the amount of spot turning, and avoid multiple passes in the same cut (with scraper applications), which can cascade material into the track.



## 9.4 Non-Warrantable Conditions

### 9.4.1 Grinding or Polishing Wear



#### NON-WARRANTY CAUSE:

- Buildup of material/debris on the track system or roller frame
- Low track tension causing buildup on the wheels

If track tension is low, or if the heavy clay or muddy operating conditions exist, it is possible that the grinding wear can be caused by track to drive wheel slip.

**APPEARANCE:** Sections of the drive wheel coating machined off smoothly with circumferential grooves visible. A drive wheel that has encountered this type of wear becomes ineffective in cleaning the ID of the track. In addition, if only one side of the drive wheel is worn, and the other is not, track alignment will be affected and guide lug damage can result.

**PREVENTION:** Periodically track system and remove any material buildup that has occurred. If buildup is a problem, consider adjusting tread gage (if possible) or switching to a more appropriate track width to better keep material out of the track system. Inspect the track system at the end of the day for build-up and remove before operating the machine again, so it cannot set up overnight and cause wear the following day. Make sure all guards and scrapers are in place. Verify track tension is correct.

## 9.4.2 Metal Cracks



**Drive Wheel, Midroller or Idler Cracks**

**WARRANTY CAUSE:** Steel defect. If caused by stress concentration, it will originate from a defective area that can be identified upon inspection and will occur at lower operational hours.

**APPEARANCE:** Cracks in the rim or around the bolt circle. Cracks can be multiple or single.

**NON-WARRANTY CAUSE:** High vertical or side loads, or abrasive wear due to inside of wheel rubbing on the track system frame. Fatigue cracks will develop in these situations during the midlife of the machine, and are application related.

Cracks originating from the bolt circle can also be caused by improper torque on the wheel to the hub, or missing or soft wheel bolt circle backing plates (if equipped)

**PREVENTION:** Periodically inspect the wheels for cracks. If cracks are found, replacement is recommended rather than repairing/welding the existing wheel. Also, inspect the area between the inside of the wheel and the frame for adequate clearance or for signs of rubbing.

### 9.4.3 Coating Separation – Excessive Heat (Midroller)



**NON-WARRANTY CAUSE:** Excessive heat due to track misalignment or steep side slope operation. This coating loss will be seen on the side of the midroller next to guide lug.

**APPEARANCE:** Polished surface will be seen on the guide lug side of the midroller, with sudden coating failure, many times only with partial separation.

**DISCUSSION:** Midroller coating loss due to excessive heat can occur due to:

- A) Track misalignment
- B) Extended operations on side slopes, ditches, or terraces
- C) Operation of an unbalanced machine (too much weight in front or rear)
- D) Installation of midroller without required spacer (some machines)

In addition, the following conditions will cause additional heat input and damage:

- Use of narrow midrollers (smaller width and less surface area to dissipate heat)
- Extending roading (more than 5-10 miles) at over 20 MPH
- High ambient temperature conditions
- Heavy drawbar vertical loads or fully mounted hitch vertical loads
- Operation with new & clean track system components( break-in period)

**PREVENTION:** Verify track alignment using manufacturer’s specifications. Internal damage to the track may cause it to come out of alignment, so it is important to check alignment on a periodic basis. **Drive wheels must be positioned correctly on track systems with axle adjustable gauge width.**

Avoid use of excessive ballast, and verify balance is correct. Use the correct track/midroller combination for the application to avoid edge damage. Avoid high speed roading, especially at high ballasted weights and in high ambient conditions. Always monitor the condition of the track system. Worn pins and bushings can cause tracks to become misaligned and cause midroller damage.

#### 9.4.4 Outboard Edge Wear (Midrollers)



#### NON-WARRANTY CAUSE:

- Normal Wear
- High localized loads
- Abrasive, flint, or rocky soils
- Operation in narrow beds (material cascading into track system)

**APPEARANCE:** Edge areas of the midroller coating are chipped or chunked.

**DISCUSSION:** Midrollers which have significant nicks or chunks missing can continue to operate for a substantial amount of time, especially if the cause of the damage is identified and minimized or eliminated. If the cuts have progressed through the coating to the steel wheel below, then the life of the wheel may be reduced as the coating slowly erodes away due to fatigue and rock/dirt can get pressed under the coating surface.

Midrollers will continue to perform their intended function with this type of damage and should not be replaced until they meet the following replacement criteria:

- *More than 1/3 of the midroller coating is lost around the entire wheel*
- *Any area where midroller coating loss extends across entire midroller width*
- *Midroller no longer turns freely*
- *Midroller face begins to build-up with dirt due to lack of coating thickness*

**NOTE: REPLACE MIDROLLERS IN SETS IF SIGNIFICANT WEAR IS SEEN ON THE OPPOSITE SIDE ON SAME AXLE – Do not pair a worn midroller on the same axle as a new midroller, or overloading of the opposite side midroller may occur.**

**PREVENTION:** Avoid operation in very rocky or abrasive soil. If operation is required, make sure to balance the machine and avoid excessive weight. Consider ways to reduce recirculation of material on top of the midrollers and through the track system.

### 9.4.5 Stuck Wheel (Midroller)



**NON WARRANTY CAUSE:** Excessive heat and abrasion due to loss of rotation on midroller during operation. Midroller rubber loss due to lack of rotation can occur from:

- Ice Buildup (winter operations where freezing has occurred while parked)
- Failed bearing/seal causes mechanical seizing of hub
- Buildup of debris or other material between midroller and frame or other wheels

**PREVENTION:** Always monitor the condition of the track system. Especially during winter operation, check the rotational movement of each wheel before daily operation, or after extended parking, which low temps could allow wheels to freeze up.

**NOTE:** If the midroller will no longer rotate freely due to the flat spot, and has worn all the way across the diameter of the wheel, it must be replaced as soon as possible, and the root cause identified (hub seized, ice buildup, etc.), or track damage will result.

## 9.4.6 Mechanical Damage



**NON-WARRANTY CAUSE:** Material ingestion, cutting, or other damage due to debris. In some cases, may also be heat and load related.

**APPEARANCE:** Coating is pitted, chunked, or damaged in a random fashion.

**DISCUSSION:** This kind of damage is non-disabling and the machine should continue to run. Do not replace the coated wheels unless they meet replacement criteria documented in earlier sections.

**PREVENTION:** Always monitor the condition of the track system. Limit the amount of spot turning you do to minimize material ingestion into the track system.

## 9.4.7 Rubber Splitting / Tearing (Idler)

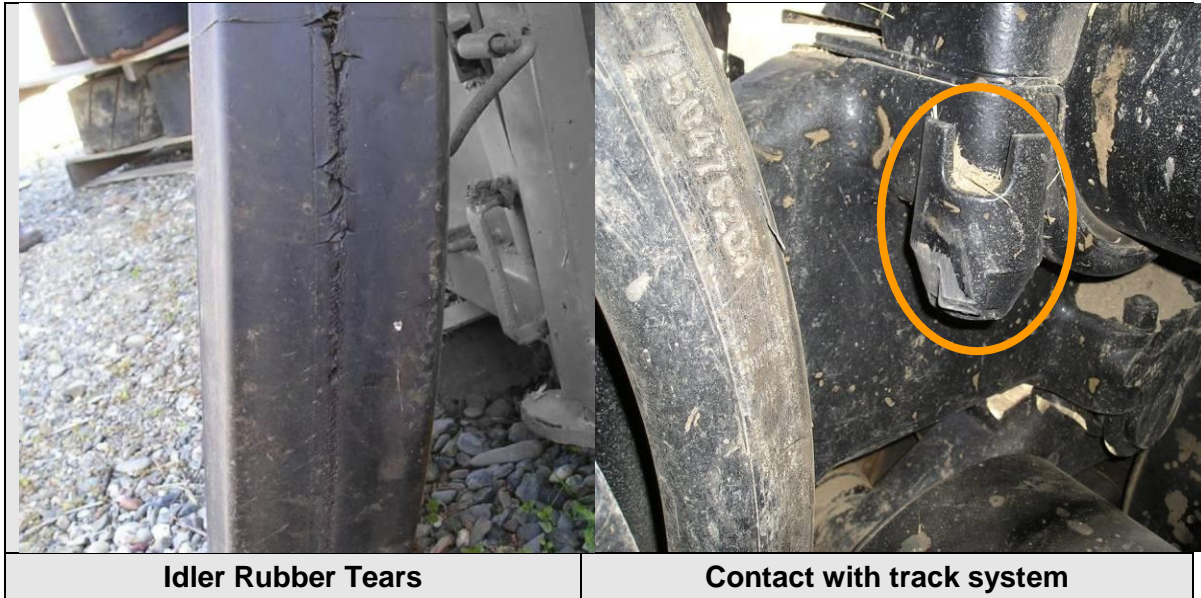

**NON-WARRANTY CAUSE:** Mechanical damage from front idler recoil event causing track frame contact.

**APPEARANCE:** Sections of the idler coating are scratched, torn, or split circumferentially around the wheel.

**PREVENTION:** Maintain proper track tension. Also, avoid machine operations the result in high impact situations to front idler. Avoid excessive material ingestion. Reduce speeds when approaching slope transitions.

## 10 Disabling Tracks and Wheels for Warranty

### 10.1 Track and Wheels Disabling



**DISCUSSION:** Depending on the failure mode, some tracks and wheels may still be usable or have reman coatings installed. If a track is replaced under warranty, the failed track is not to be continued to be used or sold without written permission from Camso. If a track warranty replacement is approved, Camso in many cases will require the track to be disabled prior to warranty credit being issued. This assures that the track can no longer be used or sold after the warranty credit is issued.

To be considered for warranty reimbursement, the track must be disabled by cutting through the entire thickness of the carcass at least 4 inches deep from one side. The cut should be near the serial number strip on the edge of the track so as a picture can be taken and shows the detail of the track being disabled and the serial number of the track in the same picture.



## 11 Track Storage Guidelines

In order for Camso tracks to provide good performance and durability for a period up to five years after date of manufacture, the following storage conditions should be observed:



### Individual Track Storage

#### Temperature

- The storage temperature of rubber tracks should be below 25°C/77°F.
- Store away from sources of heat such as boilers, radiators and direct sunlight, in a ventilated room free from excessive air currents.
- If the storage temperature is below 0°C/32°F, care should be exercised during the handling of stored rubber tracks as they may have stiffened and become susceptible to distortion if not handled carefully. The temperature of tracks taken from such low-temperature storage should be raised to approximately 15°C/59°F throughout their mass before the tracks are put into service.

#### Humidity

- The relative humidity should be such that, given the variations of temperature in storage, condensation does not occur. The relative humidity of the atmosphere in storage should be less than 60%.

#### Light

- Tracks should be protected from light sources, in particular direct sunlight or intense artificial light having a high UV content.
- **It is not recommended to store rubber tracks outside.** It is recommended that tracks be protected from direct sunlight with opaque or UV resistant covering if outside for an extended period of time.

#### Radiation

- Precautions shall be taken to protect stored rubber tracks from all sources of ionizing radiation likely to cause damage to the rubber tracks.

## **Ozone**

- As ozone is particularly detrimental to rubber, storage rooms should not contain any equipment that is capable of generating ozone such as mercury vapor lamps, electric motors or high-voltage electrical equipment giving rise to electric sparks.
- Combustion gases and organic vapors should be excluded from storage rooms as they may give rise to ozone via photochemical processes.

## **Storage of Palletized Tracks**

- Palletized rubber tracks shall not be stacked more than four pallets high and should have a plywood separator between each pallet.
- Rubber tracks may be bent for storage; back-bending is allowed as long as the minimum bend radius is at least 200mm (8 inches).

## **Contact with Liquids and Semi-Liquids**

- Rubber tracks should not be allowed to come into contact with liquid or semi-liquid materials such as acids, disinfectants and petroleum products like greases, gasoline, thinner, etc. or their vapors at any time during storage.

## **Contact with metals**

- Certain metals and their alloys, in particular copper and manganese, are known to have harmful effects on some rubbers. Rubber tracks should not be stored in contact with such metals except when bonded to them.

## **Contact between different products**

- Contact between products made from rubbers of different compositions should be avoided.

## **Storage of Tracks Installed on Vehicles**

- When tracks are installed on the vehicle for extended storage, i.e. more than six (6) months, it is recommended to store the vehicle with track tension released completely. NOTE: With track tension released, it is possible for the track, if a friction drive track system, to slip over the drive wheel if little or no tension is provided. Take additional measures to ensure machine does not move if track tension is reduced or eliminated during storage. It is also good practice to rotate the track by half turn so that the bottom part moves to the top part of the undercarriage every six months

## **Storage Life Limitation**

- Tracks stored for more than five (5) years should be reassessed before resale and/or use. No warranty will apply to tracks after five (5) years from the manufacture date, regardless of resale or service date.

# 12 Track System Inspection Process

Customers should use this chart when reviewing a complaint to quickly determine if the track system issue is application related, or a possible warrantable condition. If the chart indicates a possible warrantable condition, then refer to your dealer for appropriate claims procedures.

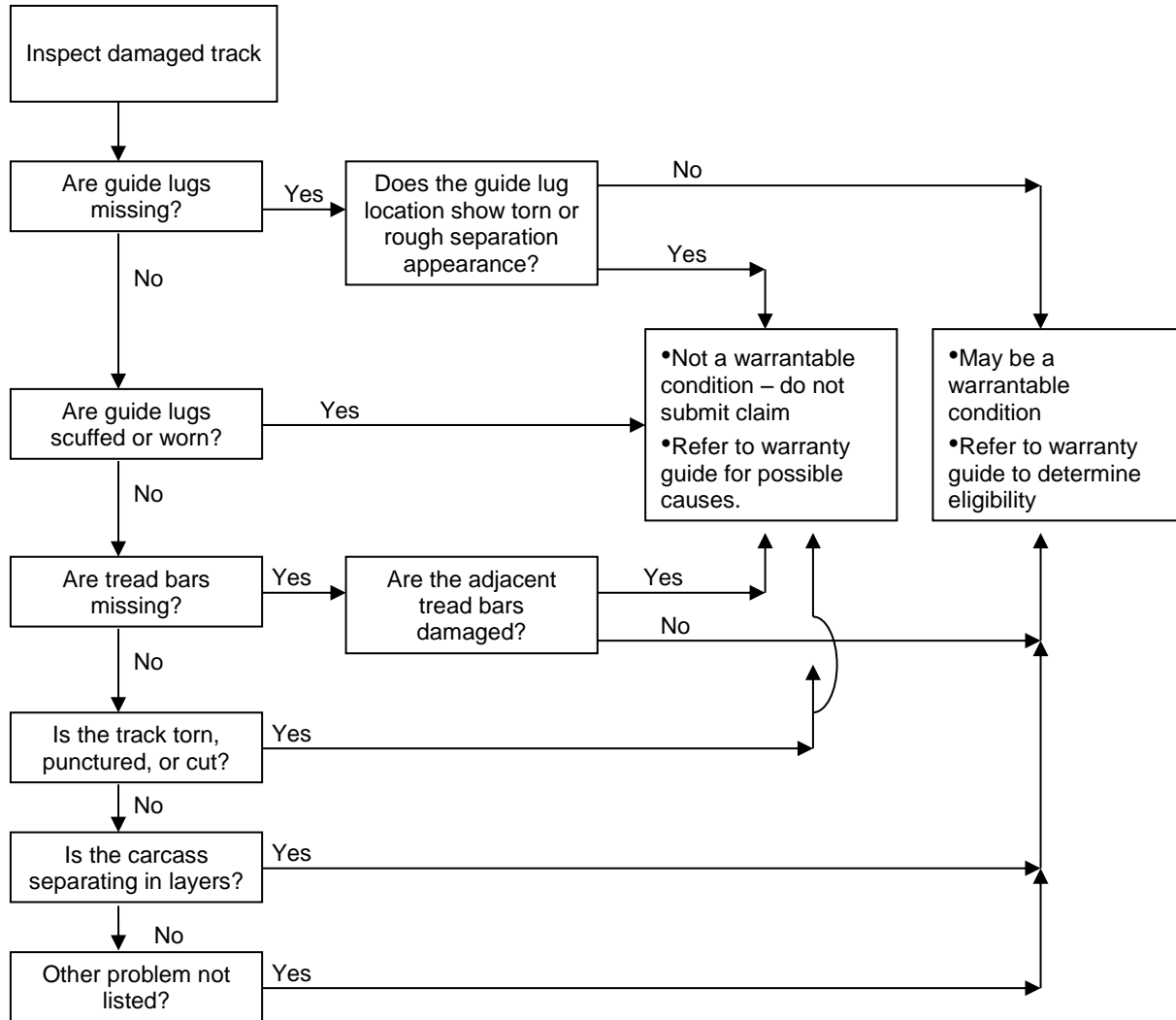

## 13 GLOSSARY of Standardized Track System Terminology

**Alignment:** Uniform parallelism of track components that minimizes the interaction between the track guide or drive lugs and wheels.

**Bias Plies:** Specialized rubber layers embedded with reinforcing wire placed at various angles to improve carcass lateral stiffness and neutralize the bias tendencies of tracks as a result of the manufacturing process.

**Berming:** The tendency for tracked machines to push up a pile of material from the sideways sliding motion of the track while turning, also known as ridging.

**Belt:** Normally known as “Track”.

**Camber:** Curvature or “bow” introduced into track system and support components to allow for a flat track footprint once axle and support deflection occurs on a fully loaded machine.

**Chevron Pattern:** A “V” tread bar pattern of alternating tread bars, with a single tread bar length of approximately one half of the width of the track. See also Diagonal pattern.

**Carcass:** The central part of the track, which includes the main cable, rubber layers, and reinforcement and bias plies.

**Chunking:** Loss of small pieces of rubber by tearing from the wear surface of the track.

**Delamination:** Separation of track carcass layers between construction sheets. This term may also refer to separation of tread bars in fine layers.

**Derailing/Untracking:** Track comes off of the drive wheel.

**Diagonal Pattern:** A tread bar pattern consisting of a single tread bar across the width of the track.

**Drift:** The tendency for a tracked machine to “pull” to one side if differences exist in the LH and RH track rolling radius. Maybe due to wear and /or mismatched track designs on each side. Drift can also be caused by gauge width misadjustment or steering system problems.

**Drive bar(s):** A series of metal bar inserts embedded into the inside surface of the track carcass for the purpose of both keeping the track retained on the undercarriage or roller frame, and also to provide a surface to transmit power to the track.

**Drive Sprocket:** A large powered wheel with teeth that engages the embedded metal drive bars and transmits power from the machine to the tracks.

**Drive Lug(s):** A series of shaped rubber blocks attached to the inside surface of the track carcass, for the purpose of both keeping the track retained on the track system or roller frame, and to also provide a surface to transmit power to the track.

**Drive wheel:** The large powered wheel (usually at the rear of the track system) that transmits power from the axle to the track via friction, drive lugs, or a combination of the two.

**Elastomeric:** A pliable material coating used to prevent material buildup on wheels.

**Friction Drive:** Track system that uses the frictional coefficient between the track and the drive wheel to transfer torque between the drivetrain and the rubber track.

**Gauge Settings:** The distance between the LH and RH track centers. Also known as “Tread Gauge” or “Tread settings”.

**Guide Lug(s):** A series of shaped rubber lugs attached to the inside surface of the track, for the purpose of keeping the track retained on the track system or roller frame. Also known in some cases as “guide blocks”.

**Inside Surface, ID:** The internal surface of the carcass on which the guide lugs are attached, and that contacts the drive wheels, idlers and midrollers.

**Inside Reinforcement:** Term used for a heavy duty carcass design in which additional layers of rubber and reinforcing plies are added between the main cables and the inside surface of the track.

**Idler Wheel:** A large non-powered wheel (usually at the front of the track system) that provides a reaction point for the track tensioning system. The idler in many cases also serves as the location for alignment adjustment.

**Inboard:** The portion of the track, from the guide lugs to the track edge that is closest to the centerline of the machine.

**Leading Edge:** When referring to tread bars, the edge of the tread bar that first engages the soil when the machine is being operated in the forward direction. This edge is to the rear on tread bars that are in contact with the soil. When referring to guide lugs, it is the edge of the guide lug that first engages a wheel when being operated in the forward direction.

**Main Cable:** The largest cable in the carcass that serves as the backbone of the track. The main cable maintains the track shape and enables it to withstand tension load without elongation.

**Midroller:** Small non-powered wheel used to distribute machine load over the track.

**Misalignment:** Condition that arises when one side of the track guide lugs are in hard contact the rolling components.

**Outside Surface, OD:** The external surface of the carcass on which the tread bars are attached, and that contacts the ground.

**Outboard:** The portion of the track, from the guide lugs to the track edge that is farthest away from the centerline of the machine.

**Positive Drive:** Track system that uses the guiding lugs (called drive lugs in this case) to transfer power from drivetrain to rubber track. Drive lugs engage drive bars in the drive wheel.

**Recoil:** The movement allowed by the tensioning system in order to allow “give” for material which may pass between the track carcass and the wheels.

**Reinforcement Plies:** Specialized bias ply layers embedded with reinforcing wires perpendicular to the main cable, in order to increase lateral stiffness and provide internal carcass protection.

**Reverse face wear:** Wear on drive lug face opposite to the forward drive contact area.

**Reversion:** Breakdown of the rubber due to overheating.

**Rock Drilling** – Sharp stone that penetrates either side of the carcass to the cable layer often in the wheel path area on the carcass ID.

**Roller frame:** Normally known as “Track system” or “Track System”. Term used for the track system excluding the track itself.

**Rolling Radius:** The distance from the center of the drive wheel axle to the center of the track main cable.

**Scuffing:** A roughened or smeared surface on the side of guide lugs as a result of minor misalignment of the track. It can also refer to the surface appearance on the tops of tread bars which can occur when turning on hard surfaces.

**Sprocket:** The drive wheel on a positive drive track system.

**Tensioning Force:** The total reaction force applied to tension the track.

**Track:** Flexible component of the track system which engages the soil.

**Track Tension:** The force seen in a given section of track, which is statically  $\frac{1}{2}$  of the tensioning force. Under normal operations, the track tension can change depending on the amount of tractive force and also on the amount of recoil in the system.

**Tractive Effort:** The amount of power that is transferred to the ground from the track.

**Trailing Edge:** When referring to tread bars, the edge of the tread bar that is the last to leave the soil when the machine is being operated in the forward direction. This edge is to the front on tread bars that are in contact with the soil. When referring to guide lugs, it is the edge of the guide lug that is the last to contact a wheel when being operated in the forward direction.

**Tread Settings:** The distance between the track centers. Also known as “Tread Gauge”.

**Tread bar(s)/Traction Lug(s):** A series of shaped rubber pieces attached to the track outside surface, and which transfer the tractive force to the ground.

**Track system:** Term normally used for the track system excluding the track itself. When referenced in the context of rubber track, the track system may also refer to a system in which the track gauge is not easily adjustable. Also referred to as roller frame or undercarriage.

**Unbonding:** Separation of rubber from a steel component.

**Untracking/Derailing:** The most common term used when a track comes off of the track system.

**Voids:** When referring to track systems, it is a defective condition where pockets of air are found inside rubber on a track or wheel.

**Wheel Path:** The portion of the inside track surface that makes contact with the wheels.

**Wheelbase:** The distance that the track is on the ground as measured front to back. This is typically measured from the centerline of the idler axle to the centerline of the drive wheel.

