

User Manual

IC-215P-AA2

Interactive Computer



About This Document

No part of this publication may be reproduced, transmitted, transcribed, stored in a retrieval system, or translated into any language or computer language, in any form or by any means, including, but not limited to, electronic, magnetic, optical, chemical, manual, or otherwise without prior written permission of MicroTouch™ a TES Company.

The information in this document is subject to change without notice. MicroTouch™ a TES Company makes no representations or warranties with respect to the contents herein, and specifically disclaims any implied warranties of merchantability or fitness for a particular purpose. MicroTouch™ a TES Company reserves the right to revise this publication and to make changes from time to time in the content hereof without obligation of MicroTouch™ a TES Company to notify any person of such revisions or changes. Windows is a registered trademark of Microsoft, Inc. Other brand or product names are trademarks of their respective holders.

Compliance Information

For FCC (USA)

This equipment has been tested and found to comply with the limits for a Class A digital device, pursuant to part 15 of the FCC Rules. These limits are designed to provide reasonable protection against harmful interference when the equipment is operated in a commercial environment. This equipment generates, uses, and can radiate radio frequency energy and, if not installed and used in accordance with the instruction manual, may cause harmful interference to radio communications. Operation of this equipment in a residential area is likely to cause harmful interference in which case the user will be required to correct the interference at his own expense.

This device complies with part 15 of the FCC Rules. Operation is subject to the following two conditions: (1) this device may not cause harmful interference, and (2) this device must accept any interference received, including interference that may cause undesired operation.

For IC (Canada)

CAN ICES-3(A)/NMB-3(A)

For CE (EU)

The device complies with the EMC Directive 2014/30/EU and Low Voltage Directive 2014/35/EU

Renseignements relatifs à la conformité

Pour la FCC (États-Unis).

Ce matériel a fait l'objet d'essais qui ont déterminé qu'il respectait les limites d'un appareil de classe A selon la partie 15 des règlements de la FCC. Ces limites sont établies pour assurer une protection raisonnable contre les parasites nuisant à un fonctionnement dans un environnement commercial. Ce matériel génère, utilise et peut émettre des ondes radio électriques, et lorsqu'il n'est pas installé et utilisé selon le manuel d'instructions, peut causer des parasites nuisant aux communications radio. L'utilisation de ce matériel dans une zone résidentielle est susceptible de causer des parasites auquel cas l'utilisateur est tenu de corriger le problème des parasites à ses propres frais.

L'appareil respecte la partie 15 des règlements de la FCC. Le fonctionnement doit respecter les deux conditions suivantes : 1) cet appareil ne doit pas causer de parasites et (2) cet appareil doit accepter tous les parasites reçus, notamment ceux pouvant causer un fonctionnement non voulu.





Pour Industrie Canada

Norme canadienne NMB-3(A)

Pour la CE (UE)

L'appareil respecte la directive 2014/30/UE relative à la compatibilité électromagnétique et la directive 2014/35/EU sur les limites de basse tension

Usage Notice

-  **Warning - To prevent the risk of fire or shock hazards, and do not expose the product to moisture.**
-  **Warning - Please do not open or disassemble the product as this may cause electric shock.**
-  **Warning - Power cord shall be connected to a socket-outlet with earthing connection.**
-  **Warning - The cable cover cannot be removed under normal use conditions.**
-  **Warning - Stability Hazard. The touch monitor may fall, causing serious personal injury or death. To prevent injury, this touch monitor must be securely attached to the wall in accordance with the installation instructions.**

Precautions

Please follow all warnings, precautions and maintenance as recommended in this user's manual to maximize the life of your unit.

Do :

- Turn off the product before cleaning.
- Use a soft cloth moistened with mild detergent to clean the product housing.
- Use only the qualified power adapter that comes with your device.
- Disconnect the power plug from AC outlet if the product is not going to be used for an extended period of time.

Don't :

- Do not use abrasive cleaners, waxes or solvents for your cleaning.
- Do not operate the product under the following conditions:
 - Extremely hot, cold or humid environment.
 - Areas susceptible to excessive dust and dirt.
 - Near any appliance generating a strong magnetic field.

Caution

Risk of explosion if battery is replaced by an incorrect type. Dispose of used batteries according to the instructions.

Avis d'utilisation



Mise en garde — Pour prévenir les risques d'incendie ou d'électrocution, ne pas exposer le produit à l'humidité.



Mise en garde — Prière de ne pas ouvrir ou démonter le produit, car cela pourrait entraîner l'électrocution.



Mise en garde – Le cordon d'alimentation doit être branché à une prise pourvue d'une mise à la terre.



Mise en garde – La gaine du câble ne doit pas être retirée en conditions normales d'utilisation.



Mise en garde — Risque de renversement. Le moniteur tactile peut se renverser et causer de graves blessures corporelles, voire la mort. Pour prévenir les blessures, ce moniteur tactile doit être solidement fixé au mur selon les instructions d'installation.

Précautions

Veillez suivre toutes les mises en garde, précautions et entretiens recommandés dans ce manuel d'utilisation pour maximiser la durée de vie de votre unité.

À faire :

- Éteindre l'appareil avant de le nettoyer.
- Utiliser un chiffon humidifié par une solution savonneuse pour nettoyer le boîtier du produit.
- Utiliser uniquement l'adaptateur d'alimentation prescrit pour votre appareil.
- Débrancher l'appareil lorsqu'il n'est pas utilisé pendant une période prolongée.

À éviter :

- Ne pas utiliser de nettoyeurs abrasifs, de cires ou de solvants pour le nettoyage
- Ne jamais utiliser l'appareil dans les conditions suivantes :
 - des conditions environnementales extrêmes (chaud, froid ou humidité)
 - des endroits remplis de poussières et de saletés.
 - à proximité d'appareils produisant un fort champ magnétique.

Mise en garde

Risque d'explosion si la batterie est remplacée par un type incorrect. Jetez les piles usagées conformément aux instructions.

Table of Contents

| | |
|--|------------|
| Chapter 1 | 7 |
| 1.1 Overview | 8 |
| 1.2 Feature..... | 8 |
| 1.3 Specifications..... | 9 |
| 1.4 Block Diagram..... | 11 |
| 1.4.2 IC-215P-AA2 | 11 |
| 1.5 Interface Connectors..... | 12 |
| 1.5.2 IC-215P-AA2 | 12 |
| 1.6 Package Overview | 15 |
| Chapter 2 | 16 |
| 2.1 About VESA Mount | 18 |
| 2.2 Power On / Off Switch..... | 20 |
| 2.3 Dimension..... | 21 |
| 2.3.1 IC-215P-AA2 (System Only) | 21 |
| 2.3.2 IC-215P-AA2 (System with Stand Module) | 22 |
| 2.4 Optional Accessory Installation | 23 |
| 2.4.1 Install the Stand Module..... | 23 |
| 2.4.2 Dismantle the Stand Module | 23 |
| 2.4.3 Install the Cables..... | 24 |
| 2.4.3.1 Cable Organizer | 24 |
| 2.4.3.2 Stand Module | 25 |
| 2.4.4 Install the Camera Module | 25 |
| 2.4.5 Dismantle the Camera Module..... | 26 |
| 2.4.6 Install the MSR Module | 26 |
| 2.4.7 Dismantle the MSR Module | 28 |
| Appendix | 306 |
| Declaration of the Presence Condition of the Restricted Substances Marking | 37 |

Chapter 1

Product Introduction

1.1 Overview

The IC-215P-AA2 series is a thinner 21.5" touch computer that offers a unique screw less design with expandability and flexibility, making expansion and accessory installation much easier. The versatility of IC-215P-AA2 Series is an exceptional choice for applications in all business sectors, especially in the retail market.

1.2 Feature

- RK3399 processor for A2 version
- Unique screw less design for better user experience.
- Patented I/O design for better wiring management while implementation.

1.3 Specifications

| System (IC-215P-AA2) | |
|---|---|
| CPU | Rock chip RK3399, Dual-core Cortex-A72 up to 1.8GHz, Quad-core Cortex-A53 up to 1.4GHz |
| GPU | Mali-T860 MP4 |
| Memory | 4GB dual channel LPDDR4 |
| Storage | 32GB eMMC |
| Input Power | DC in 12V/4A 2PIN |
| Display | Dual channel LVDS, resolution up to 1920x1080P60 |
| Touch | TPK/ZCC 21.5-inch P-Cap touch sensor (EETI 80H84 controller), supports 10 fingers touch function. |
| Audio | 2 x speaker (2W x 2) |
| Network | Gigabit Ethernet Wi-Fi 802.11a/b/g/n/ac, 1T1R Bluetooth 4.0 (Support BLE) |
| External IO Ports | 1 x LAN (Support 10/100/1000Mbps) 1 x TF slot(Support SDHC 2.0) 1 x HDMI (Support 4K@60Hz) 1 x USB3.0 Type-A 1 x USB3.0 Type-C OTG (Support DP1.2 4-lane, 5V/0.5A) 1 x 12V DC In 1 x Power button |
| Internal IO Ports (inside plastic cover) | 1 x connector (5V/0.5A) |
| OS Version | Android 9.0 or later |
| Operation Temp. | 0°C~40°C |
| Storage Temp. | -20°C to 60°C |
| Operation Humidity | 20~80%, Non-Condensing |
| Storage Humidity | 10~90%, Non-Condensing |
| LCD Touch Panel | |
| Size | 21.5" TFT LCD |
| Brightness | Typical 225 cd/m ² ; min. 200 cd/m ² |
| | |
| | |

| | |
|-----------------------|--|
| Number of Pixels | 1920 (H) × 1080 (V)/ 60Hz |
| Tilt Angle | 10°~70° |
| Environment | |
| Certificate | CE、FCC、LVD |
| Mounting | VESA 100 mm x 100 mm |
| Dimension (W x H x D) | <p>System Only</p> <ul style="list-style-type: none"> IC-215P-AA2: 510.96 mm x 308.01 mm x 37.9 mm <p>System with Stand Module</p> <ul style="list-style-type: none"> IC-215P-AA2: 510.96 mm x 322.28 mm x 172.98 mm |
| Net Weight | <p>System Only</p> <ul style="list-style-type: none"> IC-215P-AA2: 4.0 Kg <p>System with Stand Module</p> <ul style="list-style-type: none"> IC-215P-AA2: 6.52 Kg |
| Gross Weight | <p>System Only</p> <ul style="list-style-type: none"> IC-215P-AA2: 6.2 Kg <p>System with Stand Module</p> <ul style="list-style-type: none"> IC-215P-AA2: 9.07 Kg |

1.4 Block Diagram

1.4.1 IC-215P-AA2

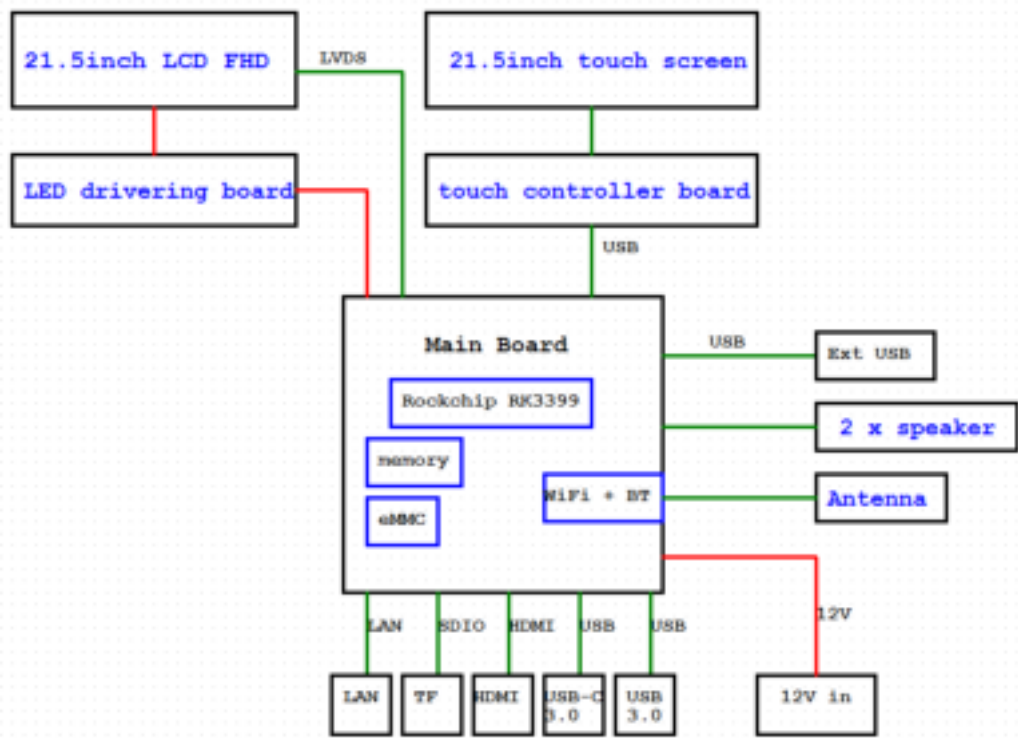

1.5 Interface Connectors

1.5 IC-215P-AA2

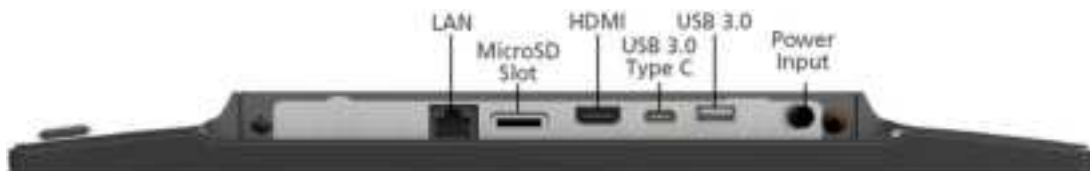

12V DC in



| Pin # | Signal Name | Pin # | Signal Name |
|-------|-------------|-------|-------------|
| 1 | 12V | 2 | GND |

RJ45 for LAN



| Pin # | Signal Name | Pin # | Signal Name |
|-------|----------------|----------------|-------------|
| 1 | TP1+ | 2 | TP1- |
| 3 | TP2+ | 4 | TP3- |
| 5 | TP3+ | 6 | TP2- |
| 7 | TP4+ | 8 | TP4- |
| LED | Function | Color | |
| Left | Active | Yellow (Blink) | |
| Right | 10M/100M/1000M | Green | |

USB3.0

| Pin # | Signal Name | Pin # | Signal Name |
|-------|-------------|-------|-------------|
| 1 | USB5V | 2 | D- |
| 3 | D+ | 4 | GND |
| 5 | SSRX- | 6 | SSRX+ |
| 7 | GND_DRAIN | 8 | SSTX- |

USB-C

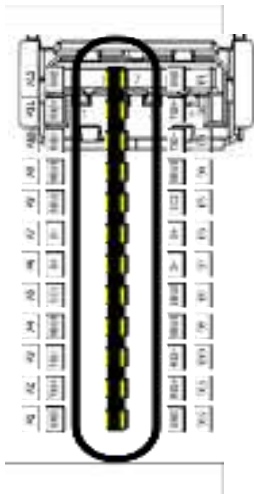

| Pin # | Signal Name | Pin # | Signal Name |
|-------|-------------|-------|-------------|
| A1 | GND | B12 | GND |
| A2 | SSTXp1 | B11 | SSRXp1 |
| A3 | SSTXn1 | B10 | SSRXn1 |
| A4 | VBUS | B9 | VBUS |
| A5 | CC1 | B8 | SBU2 |
| A6 | Dp1 | B7 | Dn2 |
| A7 | Dn1 | B6 | Dp2 |
| A8 | SBU1 | B5 | CC2 |
| A9 | VBUS | B4 | VBUS |
| A10 | SSRXn2 | B3 | SSTXn2 |
| A11 | SSRXp2 | B2 | SSTXp2 |
| A12 | GND | B1 | GND |
| 9 | SSTX+ | | |

| Pin # | Signal Name | Pin # | Signal Name |
|-------|---------------------|-------|---------------------------|
| 1 | TMDS Data2+ | 2 | TMDS Data2 Shield |
| 3 | TMDS Data2- | 4 | TMDS Data1+ |
| 5 | TMDS Data1 Shield | 6 | TMDS Data1- |
| 7 | TMDS Data0+ | 8 | TMDS Data0 Shield |
| 9 | TMDS Data0- | 10 | TMDS Clock+ |
| 11 | TMDS Clock Shield | 12 | TMDS Clock- |
| 13 | CEC (N.C on device) | 14 | Reserved (N.C. on device) |
| 15 | SCL | 16 | SDA |
| 17 | DDC/CEC Ground | 18 | +5V Power |

HDMI

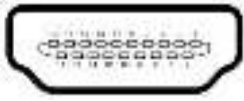

| | | | |
|----|-----------------|--|--|
| 19 | Hot Plug Detect | | |
|----|-----------------|--|--|

TF card

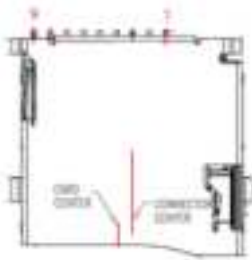

| Pin # | Signal Name | Pin # | Signal Name |
|-------|-------------|-------|-------------|
| 1 | DAT2 | 2 | DAT3 |
| 3 | CMD | 4 | VCC |
| 5 | CLK | 6 | GND |
| 7 | DAT0 | 8 | DAT1 |
| 9 | CD | | |

1.6 Package Overview



Touch Computer



Power Cord

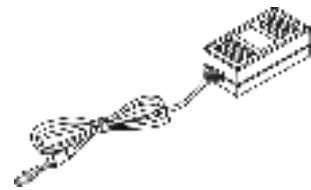

DC Power Supply



Screw

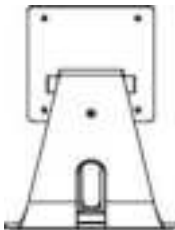

Stand Module
(Optional)

 **Warning!**

This product is intended to be supplied by a UL Listed Power Adapter, rated 12Vdc, 5A minimum. (complied with LPS or PS2) Tma = 40 degree C minimum, and the altitude of operation = 3048m minimum. If it needs further assistance with purchasing the power source, please contact to MicroTouch for further information

 **Mise en garde!**

Cet appareil est conçu avec une alimentation de courant CA, d'une tension nominale de 12Vdc, 5A minimum. (conforme au LPS ou PS2) Tma = 40 degrés C minimum et l'altitude de l'utilisation = 3048m minimum. Pour d'autres conseils pour l'installation de la source d'alimentation, communiquer avec MicroTouch pour de plus amples renseignements.

Chapter 2

Product Installation

2.1 About VESA Mount

The IC-215P-AA2 series conform to the “VESA Flat Display Mounting Interface Standard” which defines a physical mounting interface for touch computer, and corresponding with the standards of touch computer mounting devices, such as wall-mounted. The VESA mount is located on the back of this unit.

The equipment is only for wall mounting for horizontal (output connector facing down) and vertical mounting orientations (output connector facing left or right) when EUT without base. The equipment with base used for horizontal (output connector facing down) and panel facing up position.

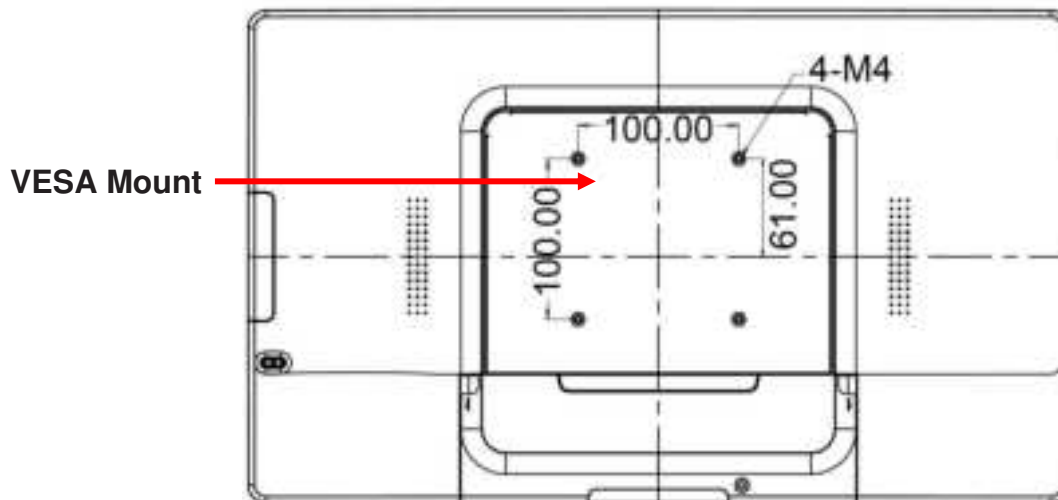

Warning!

*Please select the MicroTouch original screws!
The distance between the back cover surface and the bottom of the screw hole is 8 mm. Please use four M4 / 8 mm screws diameter with proper length to mount your monitor.*

Note: The mounting stand must be able to support at least 7.67 lbs (3.48 Kg).



Mise en garde!

Sélectionner les vis d'origine de MicroTouch!

La distance entre la surface du couvercle arrière et le bas de l'orifice de la vis est de 8 mm. Utiliser quatre vis M4 de 8 mm de diamètre pour le montage de votre moniteur.

Remarque : Le support de montage doit pouvoir supporter un poids d'au moins 7,67 lb (3,48 kg).

2.2 Power On / Off Switch

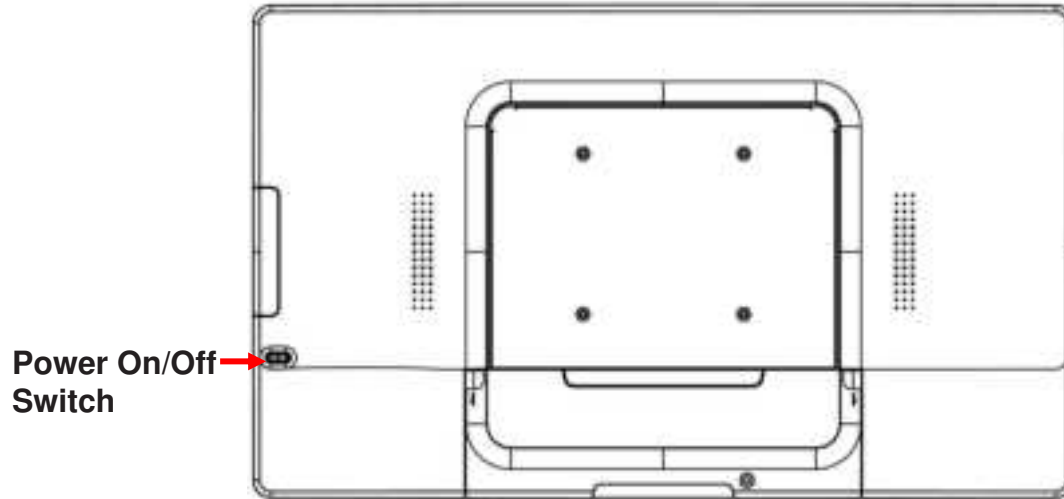

IC-215P-AA2

| Function | Description |
|-----------|--|
| Power on | Press the power button 2 sec |
| Sleep | Press the power button to enter sleep mode, and press again to resume from sleep |
| Power off | Press the power button 2 sec and click power off. |

2.3 Dimension

2.3.1 IC-215P-AA2 (System Only)

Front View

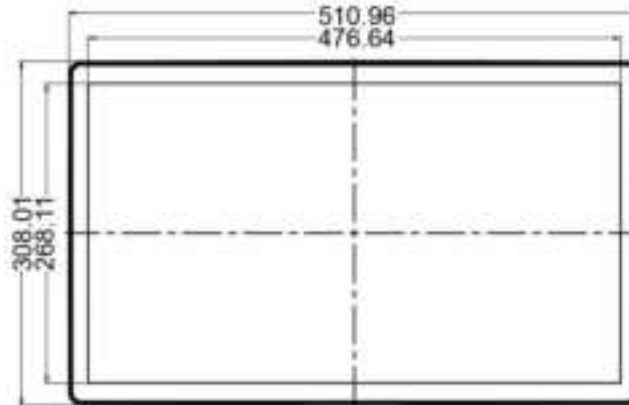

Side View



Rear View

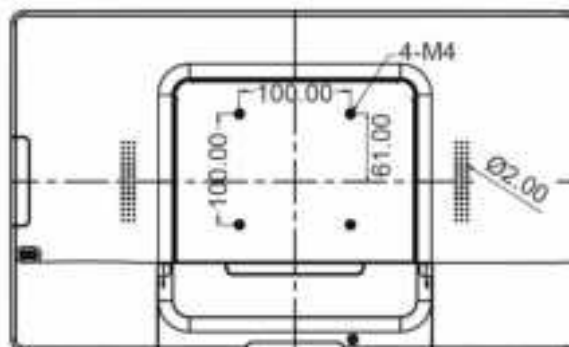

Bottom View

IC-215P-AA2

2.3.2 IC-215P-AA2 (System with Stand Module)

Front View

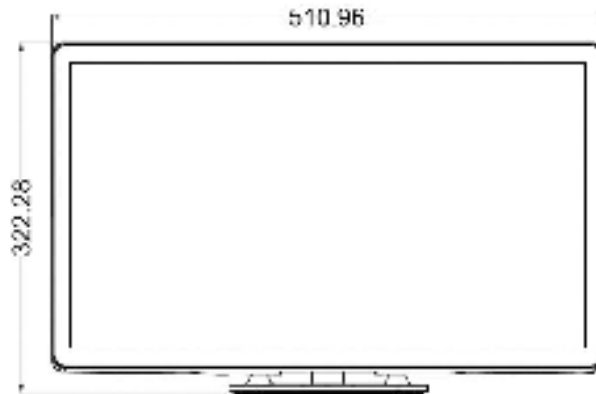

Side View

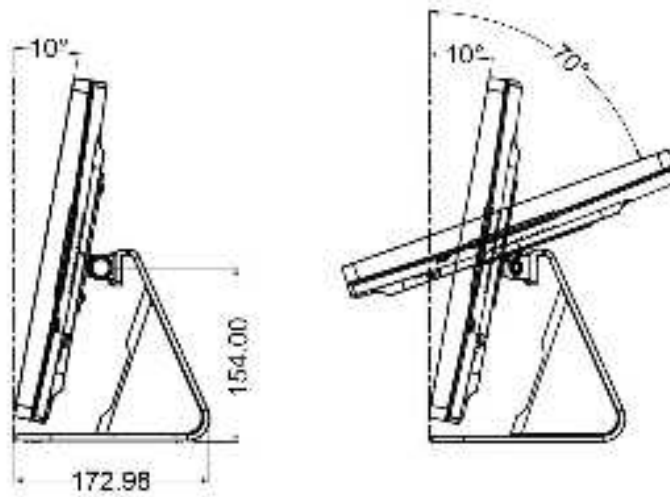

Rear View

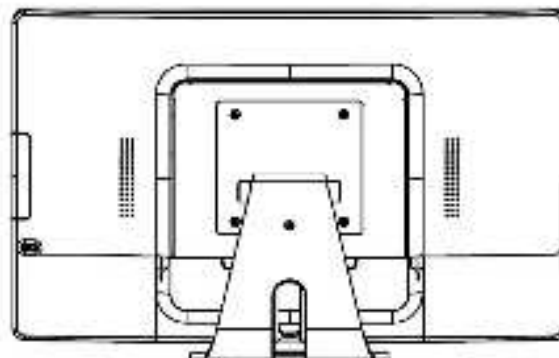

Bottom View



2.4 Optional Accessory Installation

Note: Please install/ dismantle the product when the computer system is in the shutdown state.

2.4.1 Install the Stand Module

Place stand module on back of touch computer and align the screw holes. Install the four M4 screws to fasten the stand.

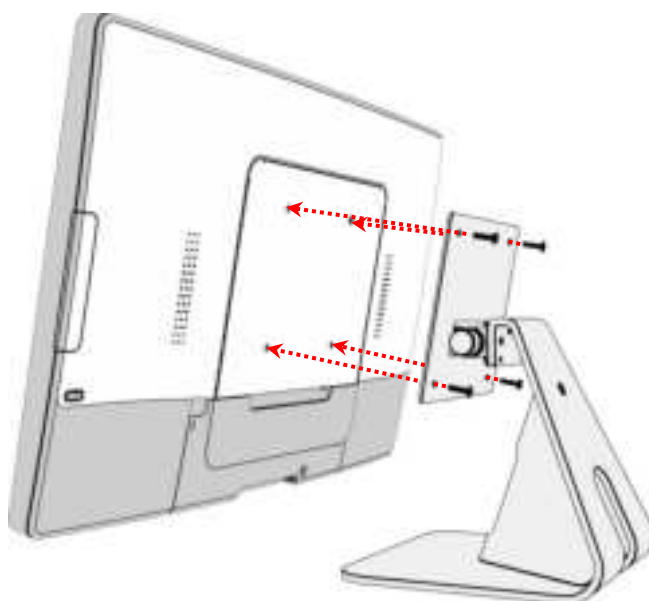

2.4.2 Dismantle the Stand Module

Step 1: Loosen the screws

Step 2: Pull it to out from touch computer and remove stand module.

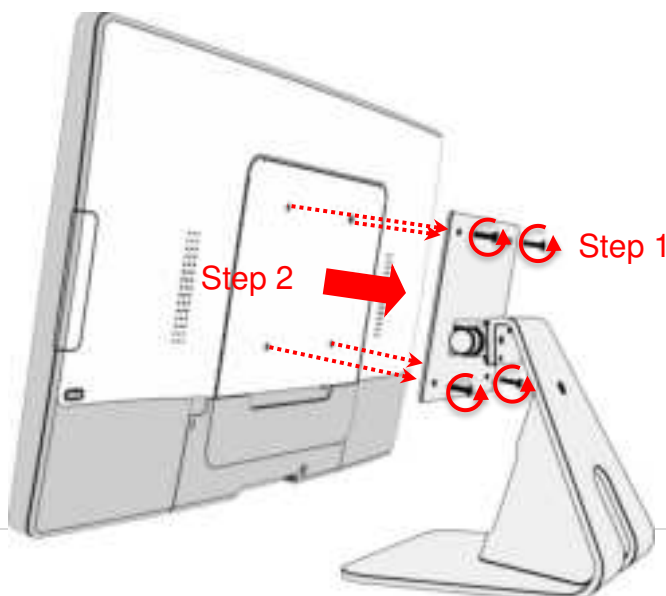

2.4.3 Install the Cables

2.4.3.1 Cable Organizer

Step 1: Pull down the cable cover for cables installation.

Step 2: To fit the plugs

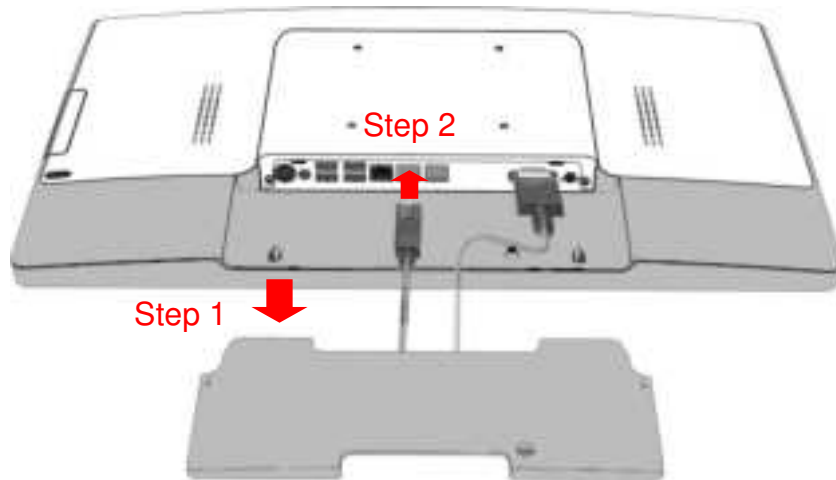

Step 3: To assemble the cable cover.

Step 4: Driving a screw to fix cable cover

(The cable can be fixed above or below the cable cover)

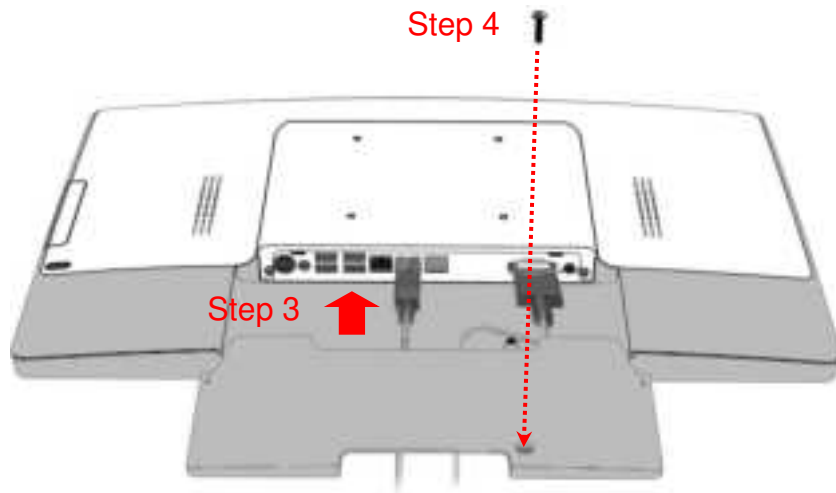

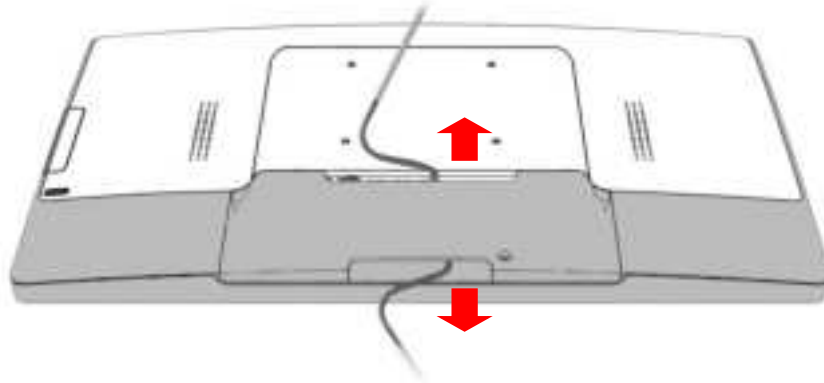

2.4.3.2 Stand Module

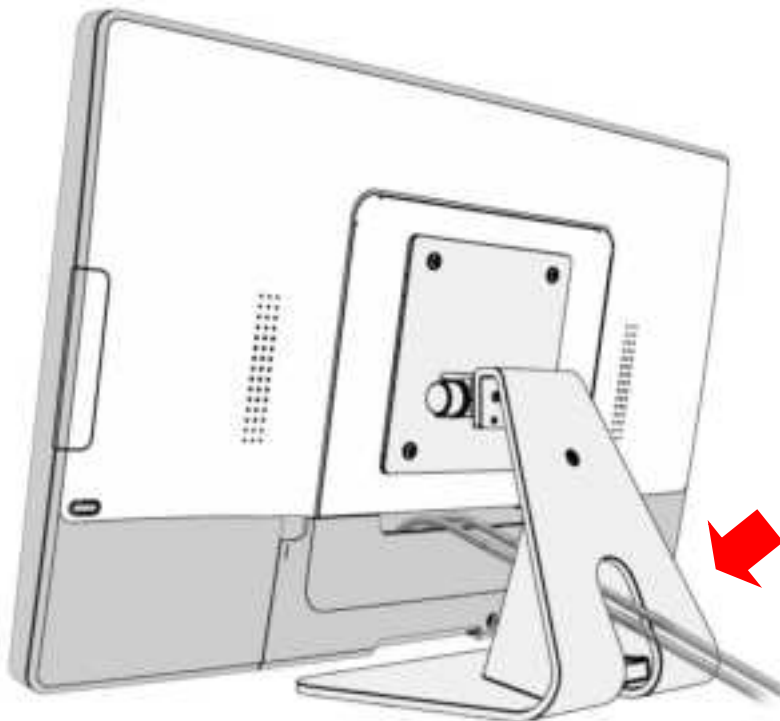

2.4.4 Install the Camera Module

Camera Module max. 19g

Step 1: Remove the side cover.

Step 2: Connect the camera module cable to the touch computer.

Step 3: Install the two M3 screws to fasten the camera module.

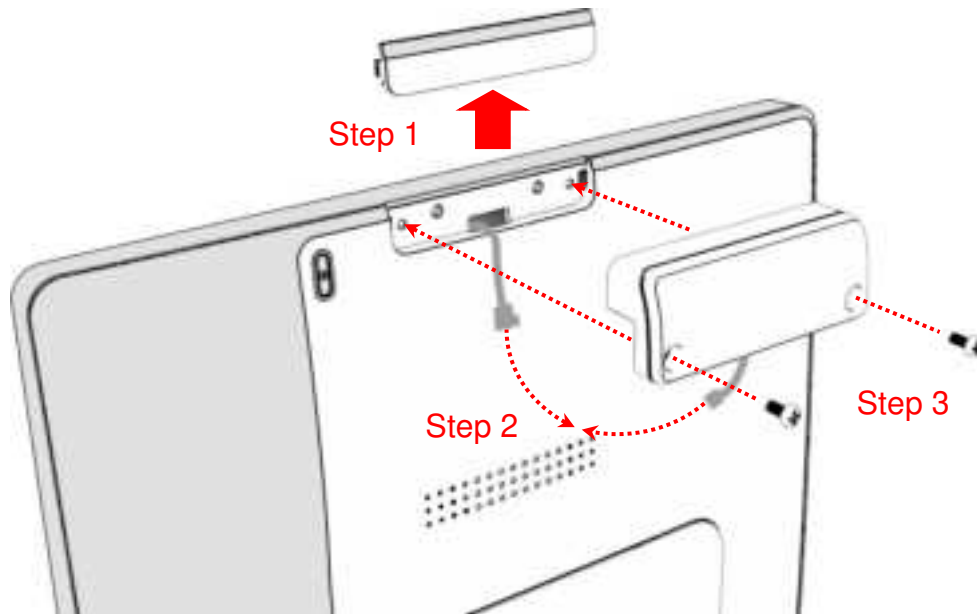

2.4.5 Dismantle the Camera Module

Step 1: Loosen the screws.

Step 2: Remove the camera module cable from the touch computer.

Step 3: To assemble the side cover.

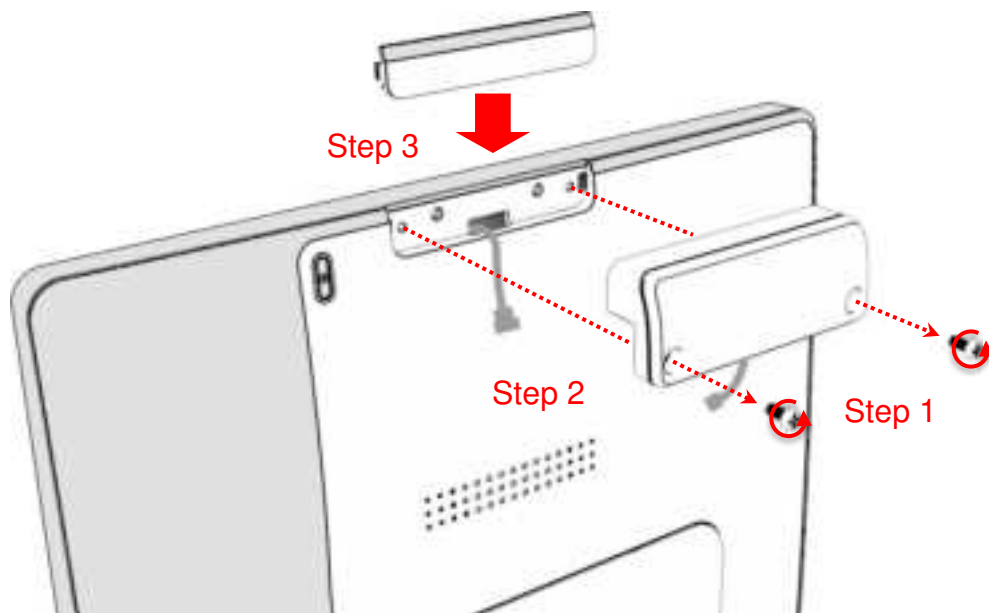

2.4.6 Install the MSR Module

MSR Module max. 62g.

Step 1: Remove the side cover.

Step 2: Connect the MSR module cable to the touch computer.

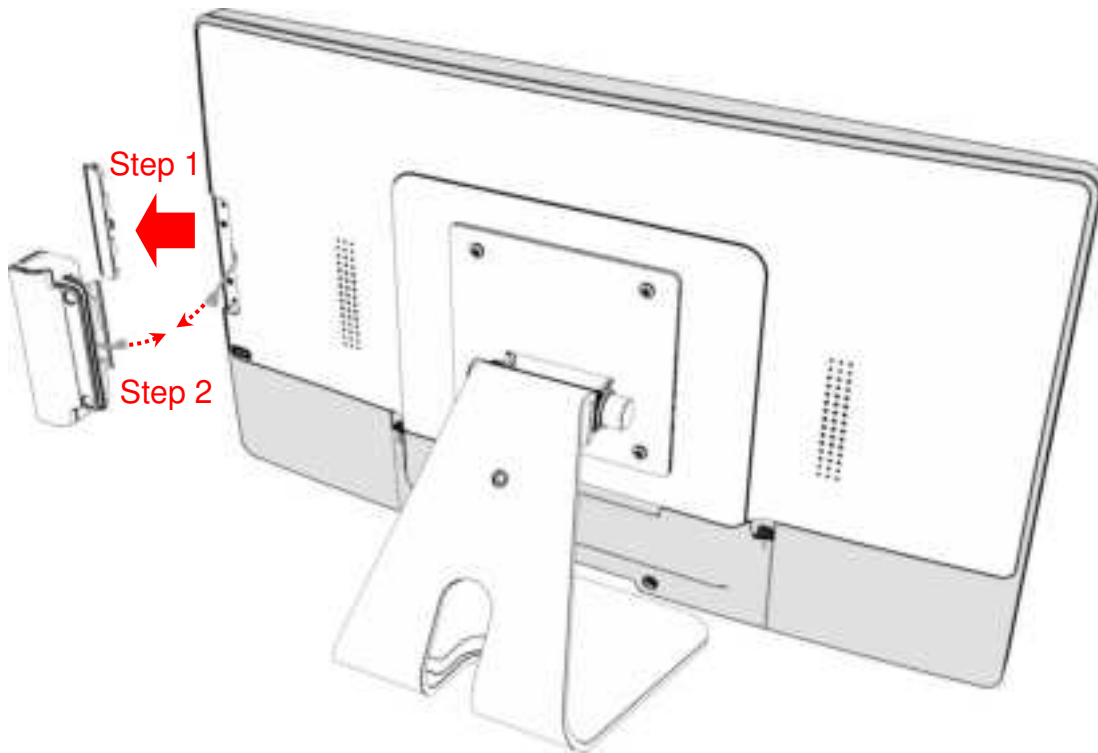

Step 3: The metal bracket hook into the gap between cover glass and bezel.

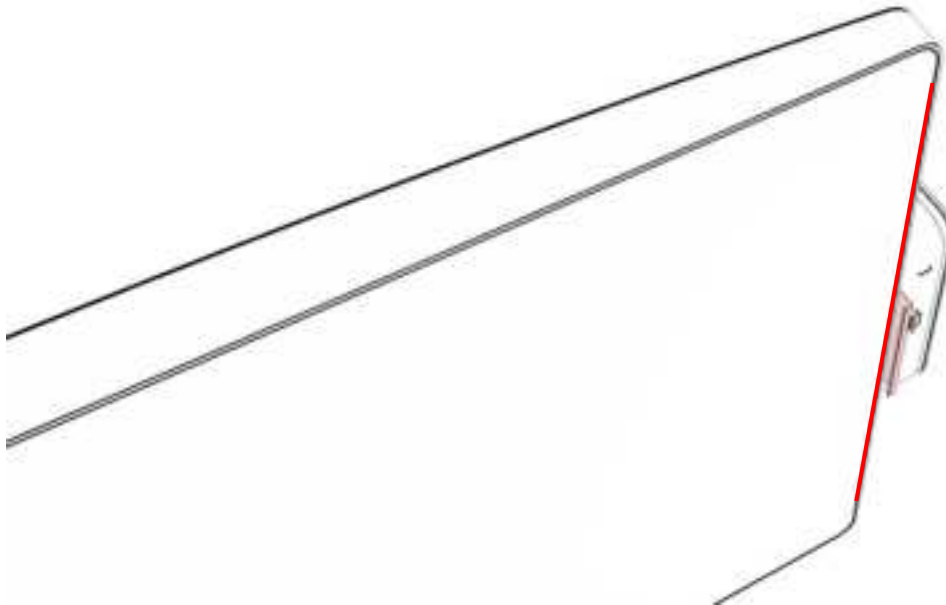

Step 4: Install the two M3 screws to fasten the MSR module.

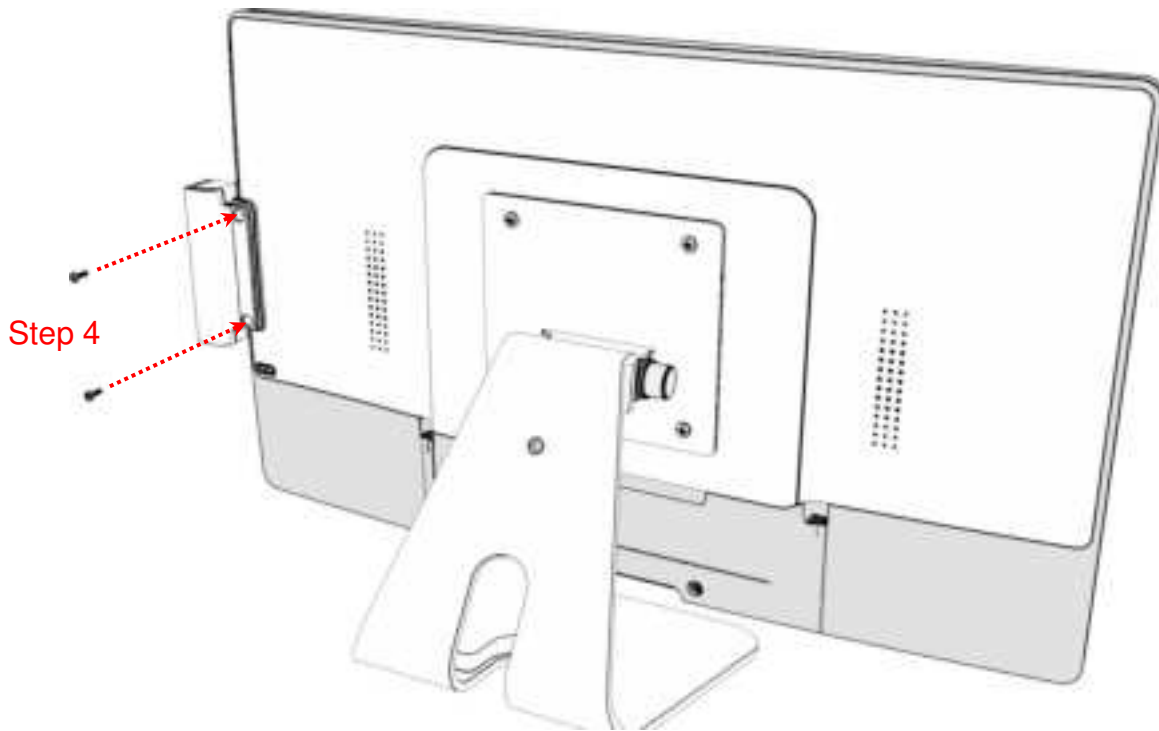

2.4.7 Dismantle the MSR Module

Step 1: Loosen the screws.

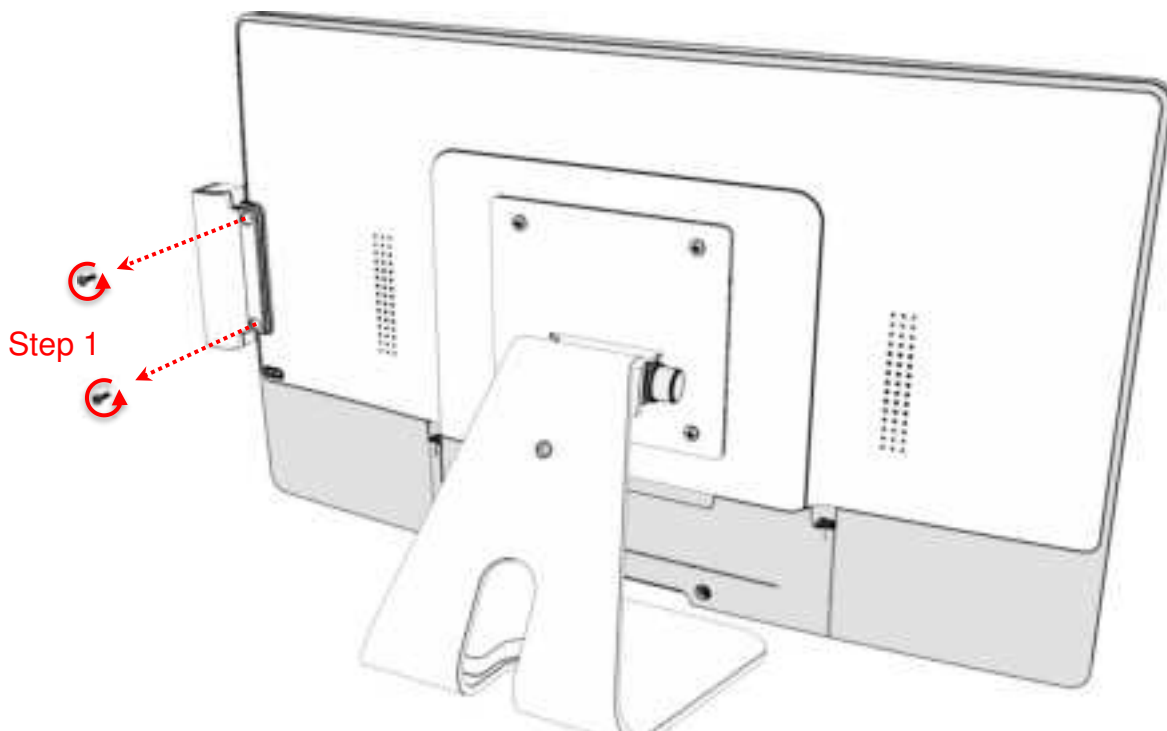

Step 2: Remove the MSR module cable from the touch computer.
Step 3: To assemble the side cover.

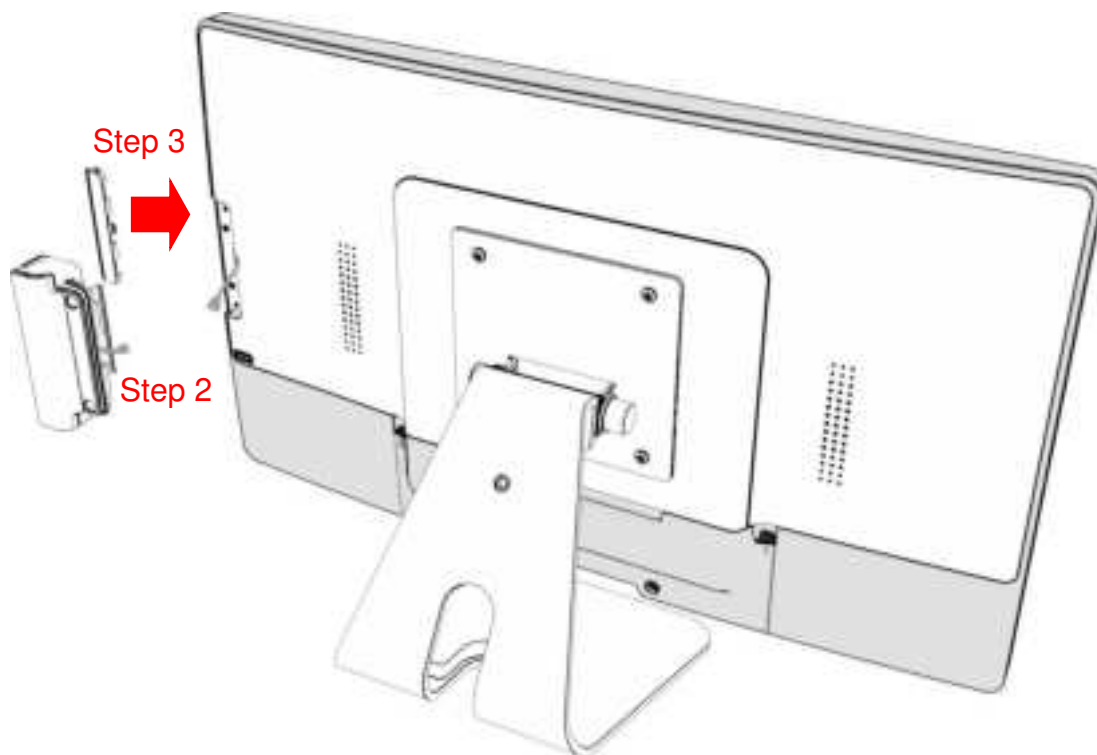

Appendix

Declaration of the Presence Condition of the Restricted Substances Marking

| | | | | | | |
|--|--|--|----------------------|--|--|--|
| 設備名稱：觸控電腦 Equipment name: Touch Computer | | 型號（型式）：IC-215P-AA2 Type designation (Type): IC-215P-AA2 | | | | |
| 單元 Unit | 限用物質及其化學符號 Restricted substances and its chemical symbols | | | | | |
| | 鉛 Lead (Pb) | 汞 Mercury (Hg) | 鎘 Cadmium (Cd) | 六價鉻 Hexavalent chromium (Cr ⁺⁶) | 多溴聯苯 Polybrominated biphenyls (PBB) | 多溴二苯醚 Polybrominated diphenyl ethers (PBDE) |
| 塑膠零件 Plastic Parts | ○ | ○ | ○ | ○ | ○ | ○ |
| 金屬零件 Metal Parts | — | ○ | ○ | ○ | ○ | ○ |
| 線纜和電纜組件 Cable component | — | ○ | ○ | ○ | ○ | ○ |
| 液晶面板 LCD Panel | — | ○ | ○ | ○ | ○ | ○ |
| 觸控式螢幕面板 Touch Panel | — | ○ | ○ | ○ | ○ | ○ |
| 電路板總成 PCBA | — | ○ | ○ | ○ | ○ | ○ |
| 軟體(光碟片等) Software | ○ | ○ | ○ | ○ | ○ | ○ |
| <p>Note 1 : “Exceeding 0.1 wt %” and “exceeding 0.01 wt %” indicate that the percentage content of the restricted substance exceeds the reference percentage value of presence condition. ◦</p> <p>Note 2 : “○” indicates that the percentage content of the restricted substance does not exceed the percentage of reference value of presence.</p> <p>Note 3 : The “—” indicates that the restricted substance corresponds to the exemption.</p> | | | | | | |