

Operating Instructions (Basic) AC Servo Motor & Driver MINAS A5-series

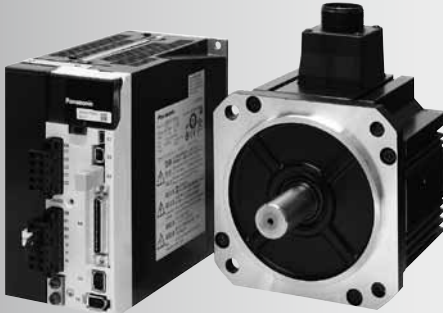

* This product image is 1.5kW type of A5-series.

- Thank you for purchasing this Panasonic product.
- Before operating this product, please read the instructions carefully, and save this manual for future use.
- This product is for industrial equipment. Don't use this product at general household.

If you are the first user of this product, please be sure to read the downloaded Operating Instructions (Overall) from our Web Site.

[Web address of Panasonic Corporation]

http://industrial.panasonic.com/ww/i_e/25000/motor_fa_e/motor_fa_e.html

Make sure to forward these Operating Instructions for safety to the final user.

<Contents>		page	page
1. Introduction	B2	Wiring to the Connector, X5	B29
On Opening the Product Package	B2	Wiring to the Connector, X6	B30
Check of the Driver Model	B2	Wiring to the Connector, X7	B32
Check of the Motor Model	B3	4. Parameter	B33
2. Installation	B4	Outline / Setup / Connection	B33
Driver	B4	Composition of Parameters	B35
Motor	B6	5. Protective Functions	B36
3. System Configuration and Wiring	B8	Protective Function (What Is Error Code ?)	B36
Overall Wiring (Connector type)	B8	6. Maintenance and Inspections	B38
Overall Wiring (Terminal block type)	B12	7. Conformity to EC Directives and UL Standards	B40
Driver and List of Applicable Peripheral Equipments	B14	Composition of Peripheral Equipments	B42
Wiring of the Main Circuit (Connector type)	B16	8. Built-in Holding Brake	B48
Wiring of the Main Circuit (Terminal block type) ...	B18	9. Dynamic Brake	B50
Wiring method to connector	B19	10. Check of the Combination of the Driver and the Motor	B51
Wiring Diagram	B21	Incremental Specifications, 20-bit	B51
Wiring of connector for motor and brake	B23	Absolute Specifications, 17-bit	B52
Wiring to the Connector, X1	B24	11. Specifications	B53
Wiring to the Connector, X2	B24	After-Sale Service (Repair)	B56
Wiring to the Connector, X3	B25		
Wiring to the Connector, X4	B26		

1. Introduction

On Opening the Product Package

- Make sure that the model is what you have ordered.
- Check if the product is damaged or not during transportation.
- Check if the Operating Instructions (safety) are included or not.
- Check if the power connector, motor connectors, connector for external regenerative resistor connection (only E-frame) and safety by-pass plug are included or not. (Neither the power connector nor motor connector are included to F-frame.)

1. Introduction

Check of the Driver Model

Contents of Name Plate

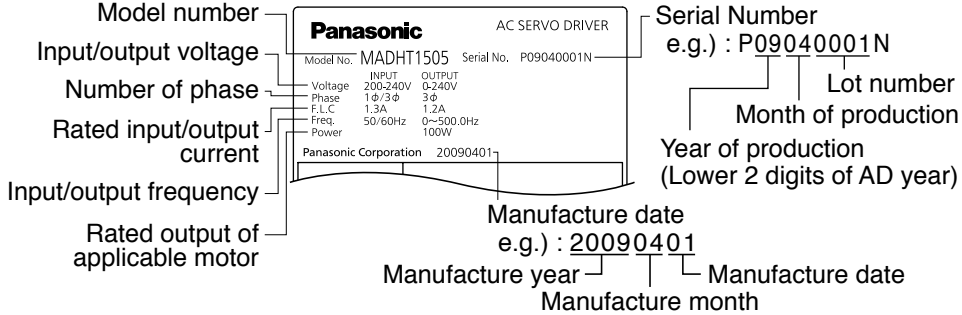

Model Designation

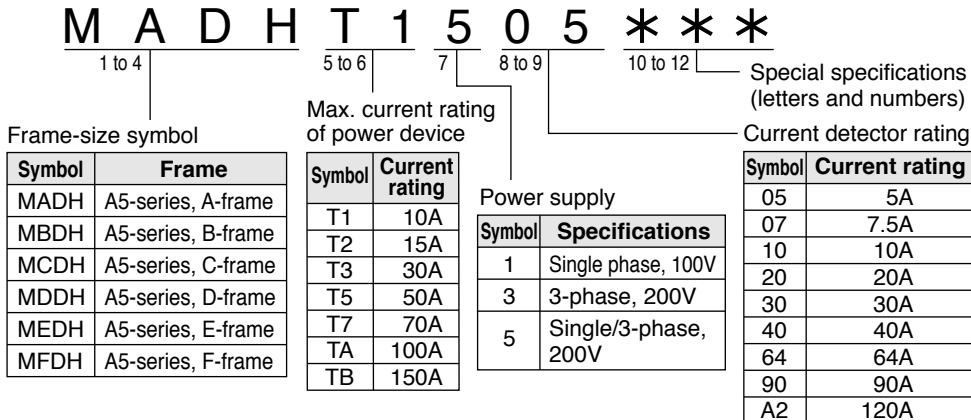

1. Introduction

Check of the Motor Model

Contents of Name Plate

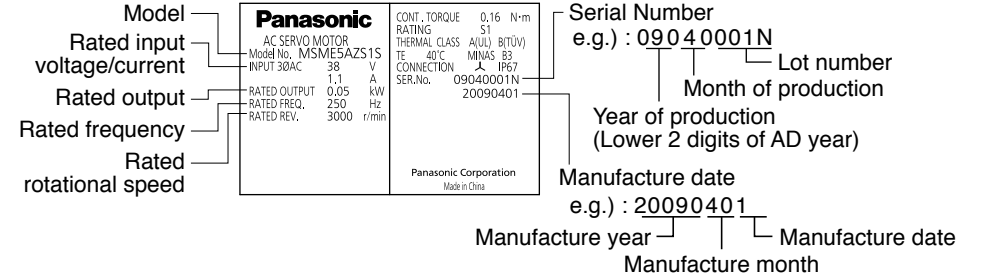

Model Designation

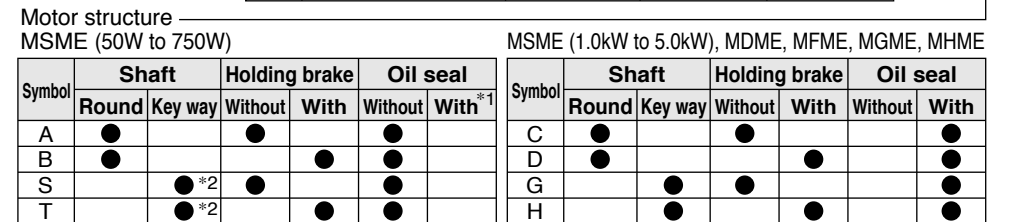
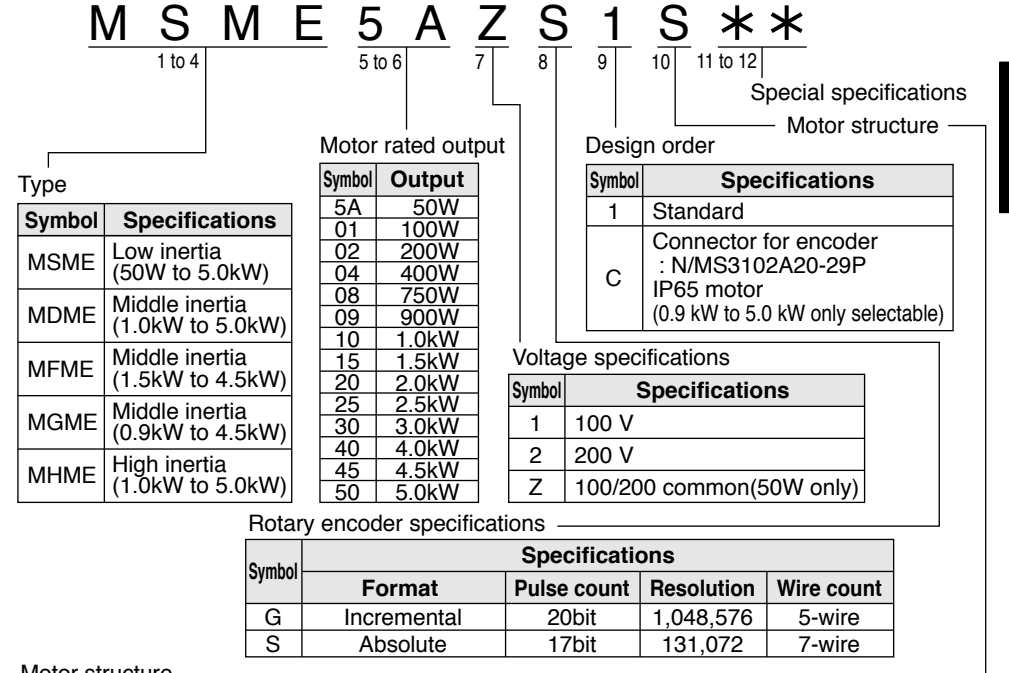

*1 The product with oil seal is a special order product. *2 Key way with center tap [Products are standard stock items or manufactured by order. For details, inquire the dealer.]

2. Installation

Driver

Install the driver properly to avoid a breakdown or an accident.

Installation Place

- 1) Install the driver in a control panel enclosed in noncombustible material and placed indoor where the product is not subjected to rain or direct sunlight. The products are not waterproof.
- 2) Where the products are not subjected to corrosive atmospheres such as hydrogen sulfide, sulfurous acid, chlorine, ammonia, sulfur, chloric gas, sulfuric gas, acid, alkaline and salt and so on, and are free from splash of inflammable gas.
- 3) Where the motor is free from grinding oil, oil mist, iron powder or chips.
- 4) Well-ventilated and low humidity and dust-free place.
- 5) Vibration-free place.
- 6) Do not use benzene, thinner, alcohol, acidic cleaner and alkaline cleaner because they can discolor or damage the exterior case.

Environmental Conditions

Item	Conditions	
Ambient temperature	0°C to 55°C (free from freezing)	*1 Extreme temperatures are permissible only for short period such as during transportation.
Ambient humidity	20% to 85% RH (free from condensation)	
Storage temperature*1	-20°C to 65°C (Max.temperature guarantee: 80°C for 72 hours free from condensation*2)	*2 Air containing water vapor will become saturated with water vapor as the temperature falls, causing dew.
Storage humidity	20% to 85% RH (free from condensation*2)	
Vibration	Lower than 5.88m/s ² (0.6G), 10 to 60Hz	
Altitude	Lower than 1000m	

How to Install

- 1) Rack-mount type. Install in vertical position, and reserve enough space around the servo driver for ventilation.
- 2) Base mount (rear mount) is standard for A/B/C/D-frame driver.
- 3) To change the mounting surface of A/B/C/D-frame driver, use the optional mounting fixture. For choosing the correct optional mounting fixture, refer to the Operating Instructions (Overall).
- 4) For the dimensions and mass of the product, which are necessary design data of the mounting section, refer to the dimensional outline drawing on the Operating Instructions (Overall) or the Delivery Specification.
- 5) In consideration of strength of the screws and the material of the mounting base, select appropriate fastening torque for the product mounting screws, so that the screws will not be loosened or damaged.
Example) To tighten a steel screw into a steel base, A to F-frame: M5 2.7 to 3.3 N·m

A to D-frame

Basemount (Standard)
[Rear mount]

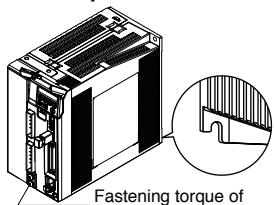

Fastening torque of earth screws (M4) to be 0.7 to 0.8 N·m.

Frontmount
[Use mounting fixture]

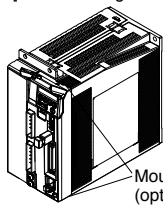

Mounting fixture (optional parts)

— B4 —

E, F-frame

Front or Basemount [Use mounting fixture]

<E-frame>
Fastening torque of earth screws (M4) to be 0.7 to 0.8 N·m.

<F-frame>
Fastening torque of earth screws (M5) to be 1.4 to 1.6 N·m.

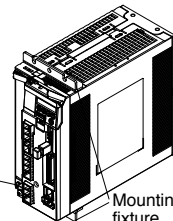

Mounting fixture (Attachment)

2. Installation

Driver

Mounting Direction and Spacing

- Reserve enough surrounding space for effective cooling.
- Install fans to provide uniform distribution of temperature in the control panel.
- D/E/F frame is provided with a cooling fan at the bottom.
- Observe the environmental conditions of the control panel described in the previous page.

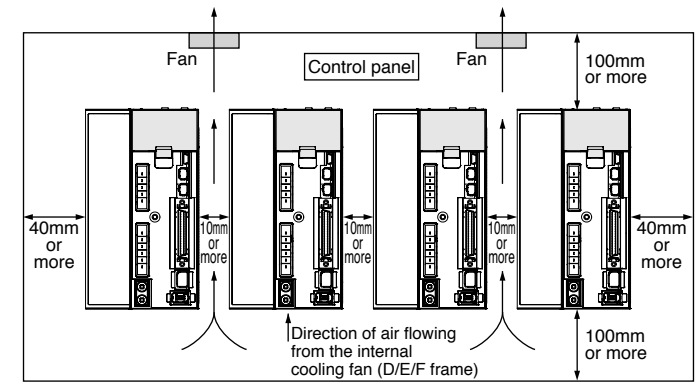

Note

It is recommended to use the conductive paint when you make your own mounting fixture, or repaint after peeling off the paint on the machine for installing the products, in order to make noise countermeasure.

Caution on Installation

- We have been making the best effort to ensure the highest quality, however, application of exceptionally large external noise disturbance and static electricity, or failure in input power, wiring and components may result in unexpected action. It is highly recommended that you make a fail-safe design and secure the safety in the operative range.
- If stranded wires are used as the cable, bunch the conductors of the cable using a rod terminals or a round terminals.
If stranded wires are used as they are, unexpected accidents such as an electric shock and short circuit or injury may result. (Refer to P.B19. "Wiring method to connector".)
- There might be a chance of smoke generation due to the failure of these products. Pay an extra attention when you apply these products in a clean room environment.
- Be sure to install a no-fuse breaker in the power supply. In addition, be sure to ground the grounding terminal or ground wire provided.
If the product is grounded insufficiently, not only the driver may not deliver its performance sufficiently, but also safety hazards such as a malfunction due to a electrification or a disturbance may be caused.
- If electric wires are bound and run through metal duct, they cannot carry the rated current due to temperature rise. If they are forced to carry the rated current, they may burn. When determining size of the wire, check the current decreasing coefficient by referring to the Operating Instructions (Overall).

— B5 —

2. Installation

Motor

Install the motor properly to avoid a breakdown or an accident.

Installation Place

Since the conditions of location affect a lot to the motor life, select a place which meets the conditions below.

- 1) Indoors, where the products are not subjected to rain or direct sun beam. The products are not waterproof.
- 2) Where the products are not subjected to corrosive atmospheres such as hydrogen sulfide, sulfurous acid, chlorine, ammonia, sulfur, chloric gas, sulfuric gas, acid, alkaline and salt and so on, and are free from splash of inflammable gas.
- 3) Where the motor is free from grinding oil, oil mist, iron powder or chips.
- 4) Well-ventilated and humid and dust-free place, far apart from the heat source such as a furnace.
- 5) Easy-to-access place for inspection and cleaning
- 6) Vibration-free place.
- 7) Avoid enclosed place. Motor may get hot in those enclosure and shorten the motor life.

Environmental Conditions

Item		Conditions
Ambient temperature*1		0°C to 40°C (free from freezing)
Ambient humidity		20% to 85% RH (free from condensation)
Storage temperature*2		-20°C to 65°C (Max.temperature guarantee: 80°C for 72 hours free from condensation*5)
Storage humidity		20% to 85% RH (free from condensation*5)
Vibration	Motor only	Lower than 49m/s ² (5G) at running, 24.5m/s ² (2.5G) at stall
Impact	Motor only	Lower than 98m/s ² (10G)
Enclosure rating	Motor only (Connector type)	IP67 (except rotating portion of output shaft and connecting pin part of the motor connector and the encoder connector)*3*4
Altitude		Lower than 1000m

*1 Ambient temperature to be measured at 5cm away from the motor.

*2 Permissible temperature for short duration such as transportation.

*3 These motors conform to the test conditions specified in EN standards (EN60529, EN60034-5). Do not use these motors in application where water proof performance is required such as continuous wash-down operation.

*4 This condition is applied when the connector mounting screw in case of motor 750W or less are tightened to the recommended tightening torque (Refer to P.B23, 30, 31). Be sure to use mounting screw supplied with the connector.

*5 Air containing water vapor will become saturated with water vapor as the temperature falls, causing dew.

How to Install

You can mount the motor either horizontally or vertically as long as you observe the followings.

1) Horizontal mounting

- Mount the motor with cable outlet facing downward for water/oil countermeasure.

2. Installation

Motor

2) Vertical mounting

- Use the motor with oil seal (make-to-order in case of motor 750W or less) when mounting the motor with gear reducer to prevent the reducer oil/grease from entering to the motor.
- 3) For the dimensions and mass of the product, which are necessary design data of the mounting section, refer to the dimensional outline drawing on the Operating Instructions (Overall) or the Delivery Specification.

Oil/Water Protection

- 1) Don't submerge the motor cable to water or oil.
- 2) Install the motor with the cable outlet facing downward.
- 3) Avoid a place where the motor is always subjected to oil or water.
- 4) Use the motor with an oil seal when used with the gear reducer, so that the oil may not enter to the motor through shaft.

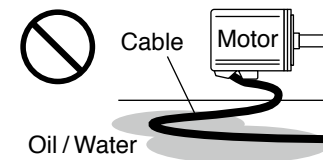

Stress to Cables

- 1) Avoid a stress application to the cable outlet and connecting portion by bending or self-weight.
- 2) Especially in an application where the motor itself travels, fix the attached cable and contain the extension junction cable into the bearer so that the stress by bending can be minimized.
- 3) Take the cable bending radius as large as possible. (When you use our optional cable, Minimum R20mm)

Permissible Load to Output Shaft

- 1) Design the mechanical system so that the applied radial load and/or thrust load to the motor shaft at installation and at normal operation can meet the permissible value specified to each model.
- 2) Pay an extra attention when you use a rigid coupling. (Excess bending load may damage the shaft or deteriorate the bearing life.)
- 3) Use a flexible coupling with high stiffness designed exclusively for servo application in order to make a radial thrust caused by micro misalignment smaller than the permissible value.

Notes on Installation

- 1) Do not apply direct impact to the shaft by hammer while attaching/detaching a coupling to and from the motor shaft. (Or it may damage the encoder mounted on the other side of the shaft.)
- 2) Make a full alignment. (incomplete alignment may cause vibration and damage the bearing.)
- 3) If the motor shaft is not electrically grounded, it may cause electrolytic corrosion to the bearing depending on the condition of the machine and its mounting environment, and may result in the bearing noise. Check and verification by customer is required.

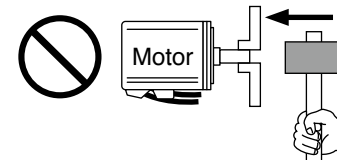

3. System Configuration and Wiring

Overall Wiring (Connector type)

Connecting Example of A to D-frame

Wiring of Main Connector (XA)

Circuit Breaker (MCCB)

To protect power supply line from overloading, install a wiring circuit breaker rated to the capacity of the power supply.

Noise Filter (NF)

Removes external noise from the power lines. And reduces an effect of the noise generated by the servo driver.

Magnetic Contactor (MC)

Turns on/off the main power of the servo driver. Use coil surge suppression units together with this.

• **Never start nor stop the servo motor with this Magnetic Contactor.**

Reactor (L)

Reduces harmonic current of the main power.

Wiring of Motor Connector (XB)

Pin B1 (6-pin), B2 (4-pin), and B3 (5-pin)

• **B2 and B3 to be kept shorted for normal operation (For C-frame and D-frame).**

• When you connect an external regenerative resistor, disconnect a short circuit wire between B2 and B3 (For C-frame and D-frame), then connect the external regenerative resistor between B1 and B2, set up Pr0.16 to 1 or 2.

Note

Note that no regenerative resistor is equipped in Frame A and B type.

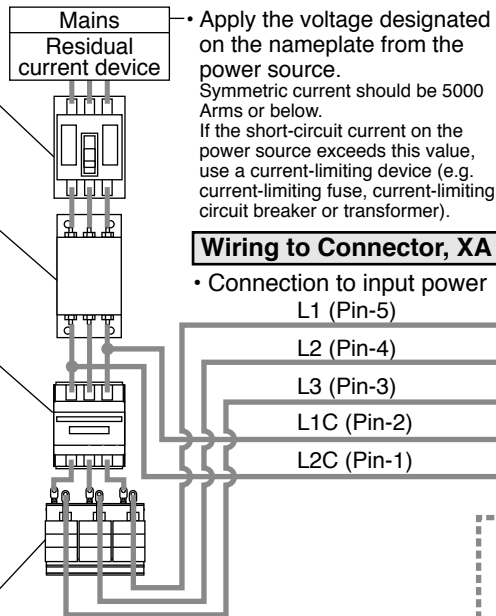

Apply the voltage designated on the nameplate from the power source. Symmetric current should be 5000 Arms or below. If the short-circuit current on the power source exceeds this value, use a current-limiting device (e.g. current-limiting fuse, current-limiting circuit breaker or transformer).

Wiring to Connector, XA

- Connection to input power
- L1 (Pin-5)
- L2 (Pin-4)
- L3 (Pin-3)
- L1C (Pin-2)
- L2C (Pin-1)

Wiring to Connector, XB

- Connection to external components

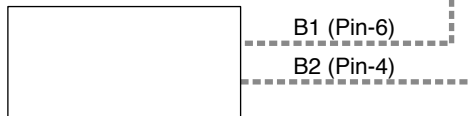

Regenerative resistor (optional)

Remarks

- When you use an external regenerative resistor, **install an external protective apparatus, such as thermal fuse without fail.**
- Thermal fuse and thermostat are built in to the regenerative resistor (Option). **If the thermal fuse is activated, it will not resume.**
- Mount the regenerative resistor **on incombustible material such as metal.**

3. System Configuration and Wiring

Overall Wiring (Connector type)

⊞: High voltage

PC (to be supplied by customer)



Setup support software "PANATERM"
Please download from our web site.

Wiring to Connector, X7

- Monitor output

Handle lever
Use this for connector connection. Store this after connection for other occasions. (Refer to P.B20 for connection.)

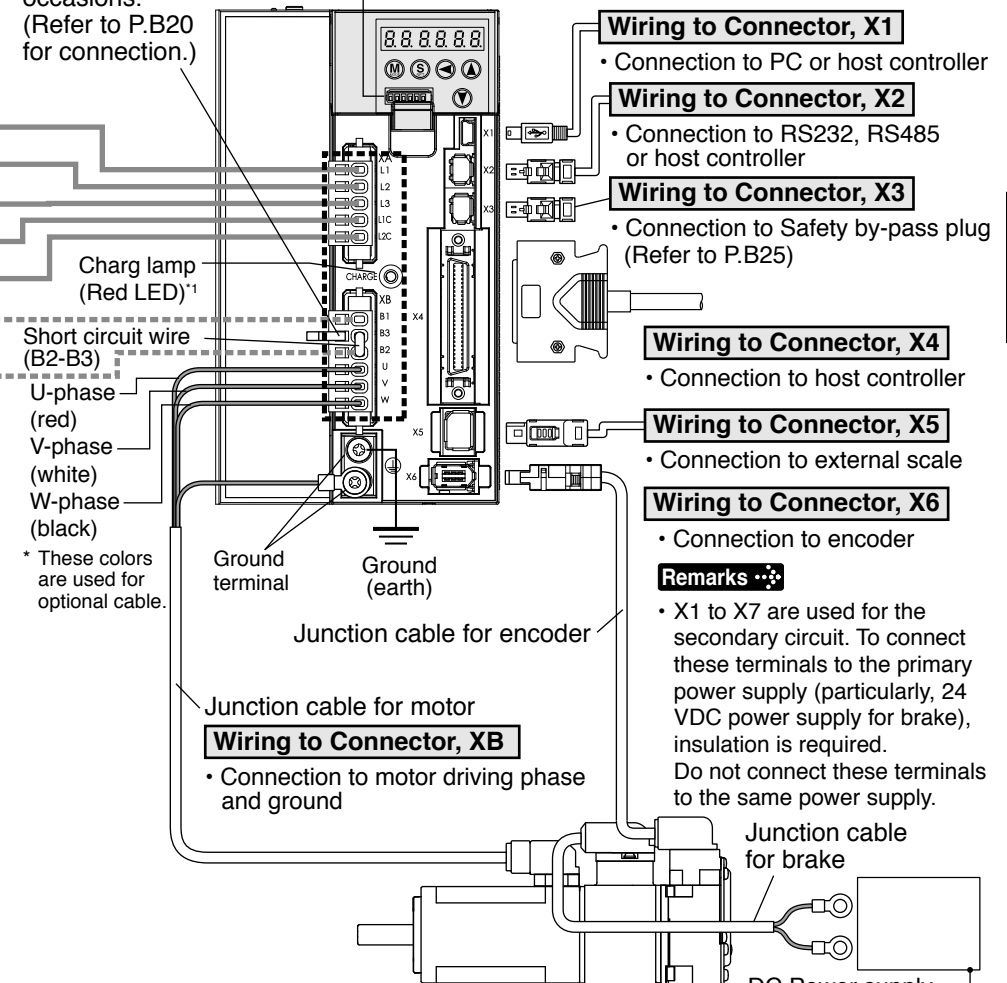

Wiring to Connector, X1

- Connection to PC or host controller

Wiring to Connector, X2

- Connection to RS232, RS485 or host controller

Wiring to Connector, X3

- Connection to Safety by-pass plug (Refer to P.B25)

Wiring to Connector, X4

- Connection to host controller

Wiring to Connector, X5

- Connection to external scale

Wiring to Connector, X6

- Connection to encoder

Remarks

- X1 to X7 are used for the secondary circuit. To connect these terminals to the primary power supply (particularly, 24 VDC power supply for brake), insulation is required. Do not connect these terminals to the same power supply.

*1 Do not make displacement, wiring or inspection while the LED is lit - cause of electric shock.

DC Power supply for brake
DC24V
(to be supplied by customer)

3. System Configuration and Wiring

Overall Wiring (Connector type)

Connecting Example of E-frame

Wiring of Main Connector (XA)

Circuit Breaker (MCCB)

To protect power supply line from overloading, install a wiring circuit breaker rated to the capacity of the power supply.

Noise Filter (NF)

Removes external noise from the power lines. And reduces an effect of the noise generated by the servo driver.

Magnetic Contactor (MC)

Turns on/off the main power of the servo driver. Use coil surge suppression units together with this.

• **Never start nor stop the servo motor with this Magnetic Contactor.**

Reactor (L)

Reduces harmonic current of the main power.

Wiring of Motor Connector (XC)

Pin B1 (4-pin), B2 (2-pin), and B3 (3-pin)

• **B2 and B3 to be kept shorted for normal operation.**

• When you connect an external regenerative resistor, disconnect a short circuit wire between B2 and B3, then connect the external regenerative resistor between B1 and B2, set up Pr0.16 to 1 or 2.

Regenerative resistor (optional)

Remarks

- When you use an external regenerative resistor, **install an external protective apparatus, such as thermal fuse without fail.**
- Thermal fuse and thermostat are built in to the regenerative resistor (Option). **If the thermal fuse is activated, it will not resume.**
- Mount the regenerative resistor on **incombustible material such as metal.**

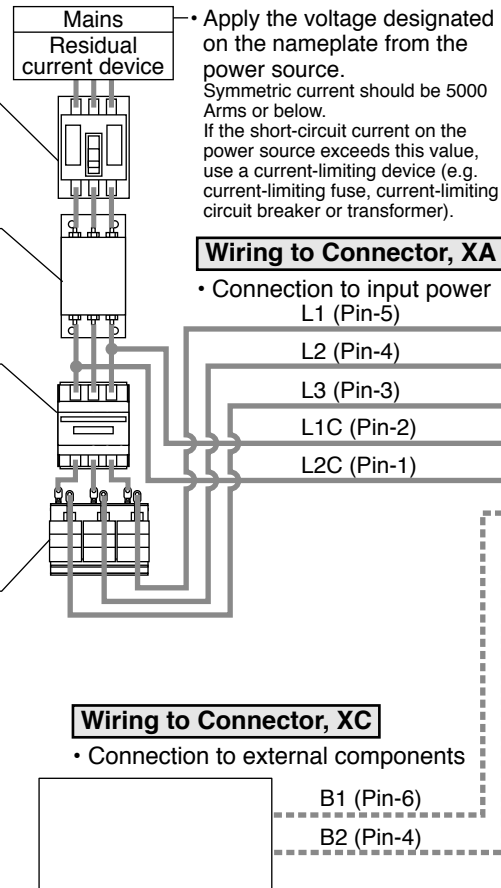

3. System Configuration and Wiring

Overall Wiring (Connector type)

⦿: High voltage

PC (to be supplied by customer)

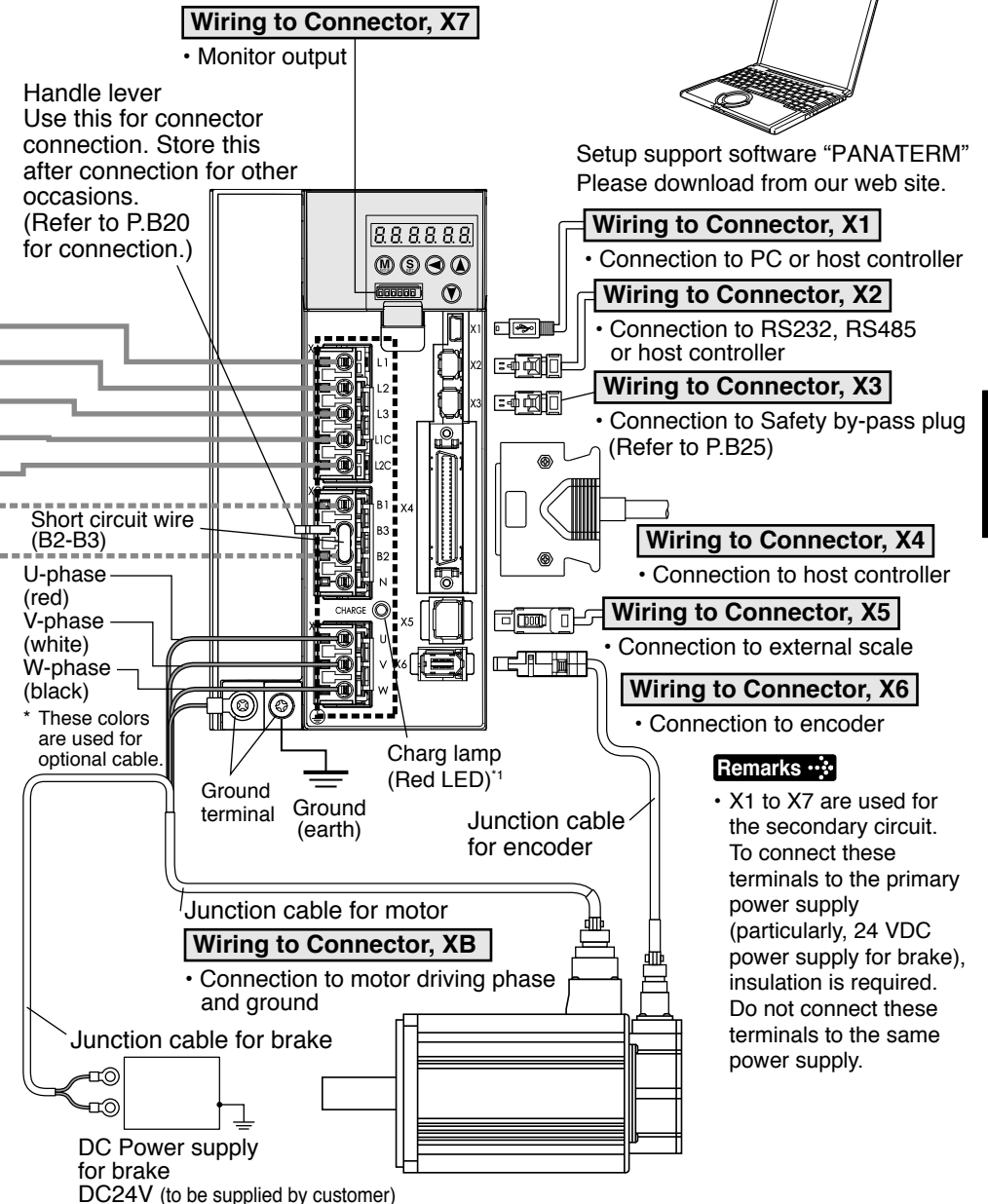

¹⁾ Do not make displacement, wiring or inspection while the LED is lit - cause of electric shock.

3. System Configuration and Wiring

Overall Wiring (Terminal block type)

Connecting Example of F-frame

Wiring of Main Connector

Circuit Breaker (MCCB)

To protect power supply line from overloading, install a wiring circuit breaker rated to the capacity of the power supply.

Noise Filter (NF)

Removes external noise from the power lines. And reduces an effect of the noise generated by the servo driver.

Magnetic Contactor (MC)

Turns on/off the main power of the servo driver.

Use coil surge suppression units together with this.

• **Never start nor stop the servo motor with this Magnetic Contactor.**

Reactor (L)

Reduces harmonic current of the main power.

Pin B1, B2 and B3

- **B2 and B3 to be kept shorted for normal operation.**
- When you connect an external regenerative resistor, disconnect a short bar between B2 and B3, then connect the external regenerative resistor between B1 and B2, set up Pr0.16 to 1 or 2.

Pin NC

- Do not connect anything.

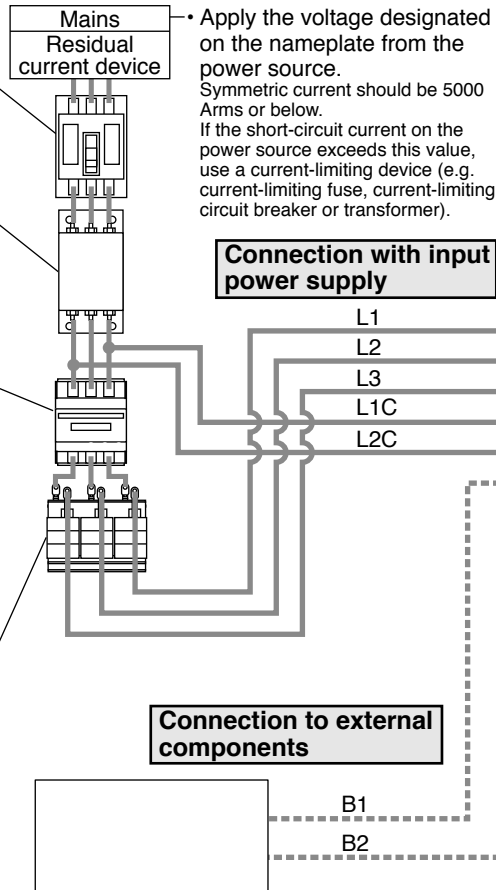

Regenerative resistor (optional)

Remarks

- When you use an external regenerative resistor, **install an external protective apparatus, such as thermal fuse without fail.**
- Thermal fuse and thermostat are built in to the regenerative resistor (Option). **If the thermal fuse is activated, it will not resume.**
- Mount the regenerative resistor on **incombustible material such as metal.**

3. System Configuration and Wiring

Overall Wiring (Terminal block type)

: High voltage

PC (to be supplied by customer)

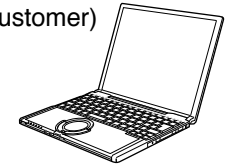

Wiring to Connector, X7

- Monitor output

Setup support software "PANATERM"
Please download from our web site.

Wiring to Connector, X1

- Connection to PC or host controller

Wiring to Connector, X2

- Connection to RS232, RS485 or host controller

Wiring to Connector, X3

- Connection to Safety by-pass plug (Refer to P.B25)

Wiring to Connector, X4

- Connection to host controller

Wiring to Connector, X5

- Connection to external scale

Wiring to Connector, X6

- Connection to encoder

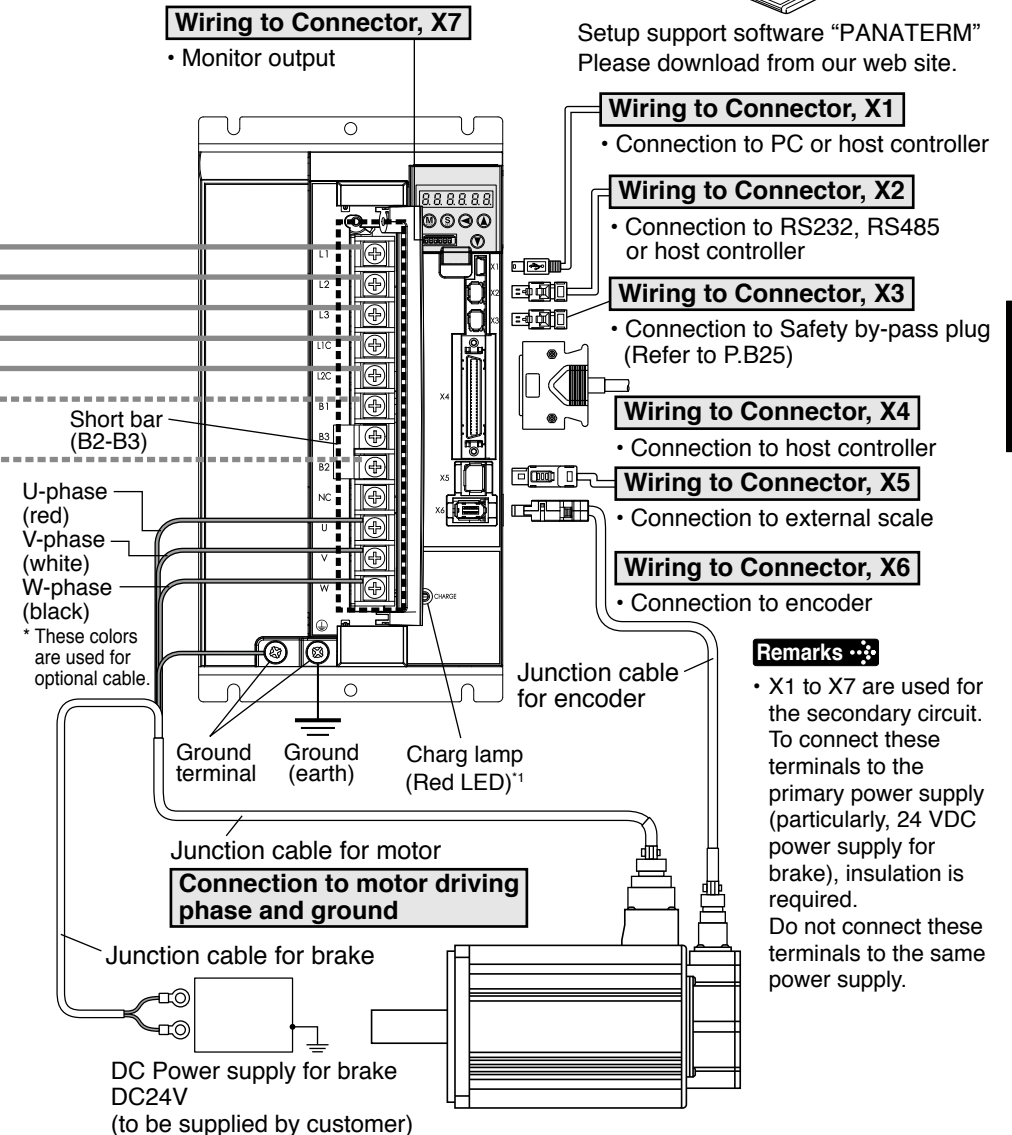

Remarks

- X1 to X7 are used for the secondary circuit. To connect these terminals to the primary power supply (particularly, 24 VDC power supply for brake), insulation is required. Do not connect these terminals to the same power supply.

*1 Do not make displacement, wiring or inspection while the LED is lit - cause of electric shock.

3. System Configuration and Wiring

Driver and List of Applicable Peripheral Equipments

Driver	Applicable motor	Voltage ^{*1}	Rated output	Required Power (at the rated load)	Circuit breaker (rated current)	Noise filter (Single phase/3-phase)	Surge absorber (Single phase/3-phase)	Noise filter for signal	Rated operating current of magnetic (contactor/Cont) configuration	Diameter and withstand voltage of main circuit cable	Crimp terminal for main circuit terminal block	Diameter and withstand voltage of control power supply cable	Crimp terminal for control power supply terminal block	Diameter and withstand voltage of motor cable ^{*2}	Diameter and withstand voltage of brake cable
MADH	MSME	Single phase, 100V	50W to 100W	approx. 0.4kVA	10A	DV0P4170	DV0P4190	DV0P1460	20A (3P+1a)	0.75mm ² / AWG18 600VAC or more	Connection to exclusive connector	0.75mm ² / AWG18 600VAC or more	Connection to exclusive connector	2.0mm ² / AWG14 600VAC or more	0.28mm ² / AWG22 to 0.75mm ² / AWG18 100VAC or more
		Single/3-phase, 200V	50W to 200W	approx. 0.5kVA		DV0P4170	DV0P4190								
MBDH	MSME	Single phase, 100V	200W	approx. 0.5kVA	10A	DV0P4170	DV0P4190	DV0P1460	20A (3P+1a)	0.75mm ² / AWG18 600VAC or more	Connection to exclusive connector	0.75mm ² / AWG18 600VAC or more	Connection to exclusive connector	2.0mm ² / AWG14 600VAC or more	0.28mm ² / AWG22 to 0.75mm ² / AWG18 100VAC or more
		Single/3-phase, 200V	400W	approx. 0.9kVA		DV0P4170	DV0P4190								
MCDH	MSME	Single phase, 100V	400W	approx. 0.9kVA	15A	DV0P4170	DV0P4190	DV0P1460	20A (3P+1a)	0.75mm ² / AWG18 600VAC or more	Connection to exclusive connector	0.75mm ² / AWG18 600VAC or more	Connection to exclusive connector	2.0mm ² / AWG14 600VAC or more	0.28mm ² / AWG22 to 0.75mm ² / AWG18 100VAC or more
		Single/3-phase, 200V	750W	approx. 1.3kVA		DV0PM 20042	DV0P4190								
MDDH	MDME	Single/3-phase, 200V	1.0kW	approx. 1.8kVA	20A	DV0P4190	DV0P1450	DV0P1460	30A (3P+1a)	2.0mm ² / AWG14 600VAC or more	Connection to exclusive connector	0.75mm ² / AWG18 600VAC or more	Connection to exclusive connector	2.0mm ² / AWG14 600VAC or more	0.28mm ² / AWG22 to 0.75mm ² / AWG18 100VAC or more
	MHME		0.9kW	approx. 1.8kVA											
	MGME		1.0kW	approx. 1.8kVA											
	MSME		1.5kW	approx. 2.3kVA											
	MFME		1.5kW	approx. 2.3kVA											
MEDH	MDME	3-phase, 200V	2.0kW	approx. 3.3kVA	30A	DV0PM 20043	DV0P1450	DV0P1460	60A (3P+1a)	0.75mm ² / AWG18 600VAC or more	Connection to exclusive connector	0.75mm ² / AWG18 600VAC or more	Connection to exclusive connector	2.0mm ² / AWG14 600VAC or more	0.28mm ² / AWG22 to 0.75mm ² / AWG18 100VAC or more
	MHME		2.5kW	approx. 3.8kVA											
MFDH	MGME	3-phase, 200V	2.0kW	approx. 3.8kVA	50A	DV0P3410	DV0P1450	DV0P1460	60A (3P+1a)	3.5mm ² / AWG12 600VAC or more	11mm or smaller Terminal block M5	0.75mm ² / AWG18 600VAC or more	11mm or smaller Terminal block M5	3.5mm ² / AWG12 600VAC or more	0.28mm ² / AWG22 to 0.75mm ² / AWG18 100VAC or more
	MDME		3.0kW	approx. 4.5kVA											
	MHME		4.0kW	approx. 6.0kVA											
	MSME		4.5kW	approx. 6.8kVA											
	MGME		4.5kW	approx. 6.8kVA											
	MDME		5.0kW	approx. 7.5kVA											
	MHME		5.0kW	approx. 7.5kVA											
	MSME		5.0kW	approx. 7.5kVA											
	MFME		5.0kW	approx. 7.5kVA											
	MGME		5.0kW	approx. 7.5kVA											

*1 Select peripheral equipments for single/3phase common specification according to the power source.

*2 The diameter of the ground cable must be equal to, or larger than that of the motor cable.

*3 Use these products to suit an international standard.

3. System Configuration and Wiring

Driver and List of Applicable Peripheral Equipments

Reference page

Noise filter.....P.B43 “Composition of Peripheral Equipments”
 Surge absorber.....P.B45 “Composition of Peripheral Equipments”
 Noise filter for signal.....P.B46 “Composition of Peripheral Equipments”
 Motor/brake connector....P.B23 “Wiring of connector for motor and brake”

• **About circuit breaker and magnetic contactor**
To comply to EC Directives, install a circuit breaker between the power and the noise filter without fail, and the circuit breaker should conform to IEC Standards and UL recognized (Listed and UL marked).
 Suitable for use on a circuit capable of delivering not more than 5,000Arms symmetrical amperes, below the maximum input voltage of the product.

Remarks Select a circuit breaker and noise filter which match to the capacity of power supply (including a load condition).

• **Terminal block and ground terminals**
 • Use a copper conductor cables with temperature rating of 75°C or higher.
 • Use the attached exclusive connector for A to E-frame, and maintain the peeled off length of 8 to 9mm. (Refer to P.B19)

• **Fastening torque list (Terminal block screw/Terminal cover fastening screw)**

Frame	Driver	Terminal block screw		Terminal cover fastening screw	
		Nominal size	Fastening torque (N·m) (*1)	Nominal size	Fastening torque (N·m) (*1)
F200V	L1, L2, L3, L1C, L2C, B1, B2, B3, NC, U, V, W	M5	1.0 to 1.7	M3	0.19 to 0.21

• **Fastening torque list (Ground terminal screw/Connector to host controller (X4))**

Driver frame	Terminal block screw		Connector to host controller (X4)	
	Nominal size	Fastening torque (N·m) (*1)	Nominal size	Fastening torque (N·m) (*1)
A to E	M4	0.7 to 0.8	M2.6	0.3 to 0.35
F	M5	1.4 to 1.6		

(*1)

- Applying fastening torque larger than the maximum value may result in damage to the product.
- Do not turn on power without tightening all terminal block screws properly.
- Do not turn on power without tightening all terminal block screws properly, otherwise, loose contacts may generate heat (smoking, firing).
- To check for looseness, conduct periodic inspection of fastening torque once a year.

Caution

Be sure to conduct wiring properly and securely. Insecure or improper wiring may cause the motor running out of control or being damaged from overheating. In addition, pay attention not to allow conductive materials, such as wire chips, entering the driver during the installation and wiring.

3. System Configuration and Wiring

Wiring of the Main Circuit (Connector type)

A to D-frame, 100 V / 200 V type

- Wiring should be performed by a specialist or an authorized personnel.
- Do not turn on the power until the wiring is completed.
- Never touch the power connector (XA and XB) to which high voltage is applied. There is a risk of electric shock.

• Tips on Wiring

- 1) Wire connector (XA and XB).
- 2) Connect the wired connector to the driver. Fully insert the connector to the bottom until it clicks.

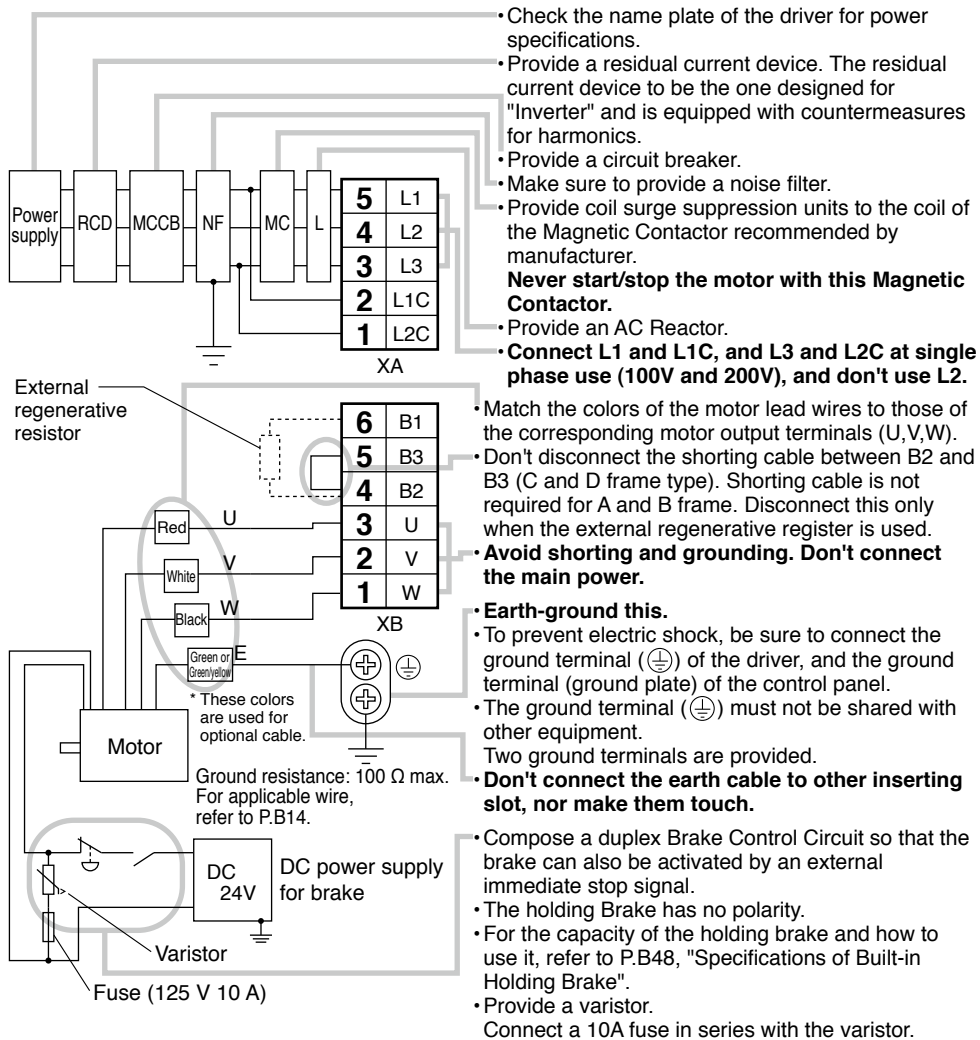

3. System Configuration and Wiring

Wiring of the Main Circuit (Connector type)

E-frame, 200 V type

- Wiring should be performed by a specialist or an authorized personnel.
- Do not turn on the power until the wiring is completed.
- Never touch the power connector (XA, XB and XC) to which high voltage is applied. There is a risk of electric shock.

• Tips on Wiring

- 1) Wire connector (XA, XB and XC).
- 2) Connect the wired connector to the driver. Fully insert the connector to the bottom until it clicks.

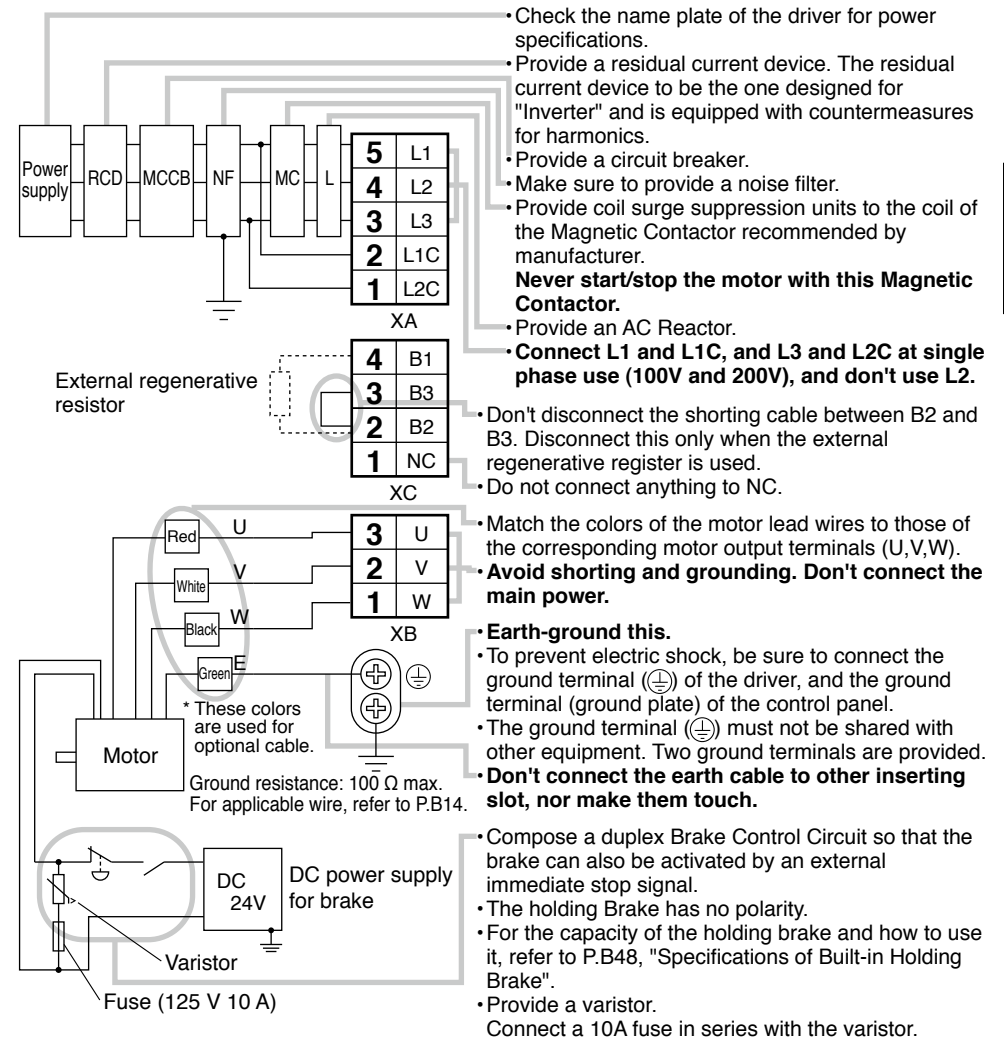

3. System Configuration and Wiring

Wiring of the Main Circuit (Terminal block type)

F-frame, 200 V type

- Wiring should be performed by a specialist or an authorized personnel.
- Do not turn on the power until the wiring is completed.
- Never touch the terminal to which high voltage is applied. There is a risk of electric shock.

• Tips on Wiring

- 1) Take off the cover fixing screws, and detach the terminal cover.
- 2) Make wiring
Use clamp type terminals of round shape with insulation cover for wiring to the terminal block. For cable diameter and size, refer to "Driver and List of Applicable Peripheral Equipments" (P.B14).
Tighten the terminal block screw with a torque between 1.0 and 1.7 N·m.
- 3) Attach the terminal cover, and fix with screws.
Tighten the screw securing the cover with a torque written on P.B15.

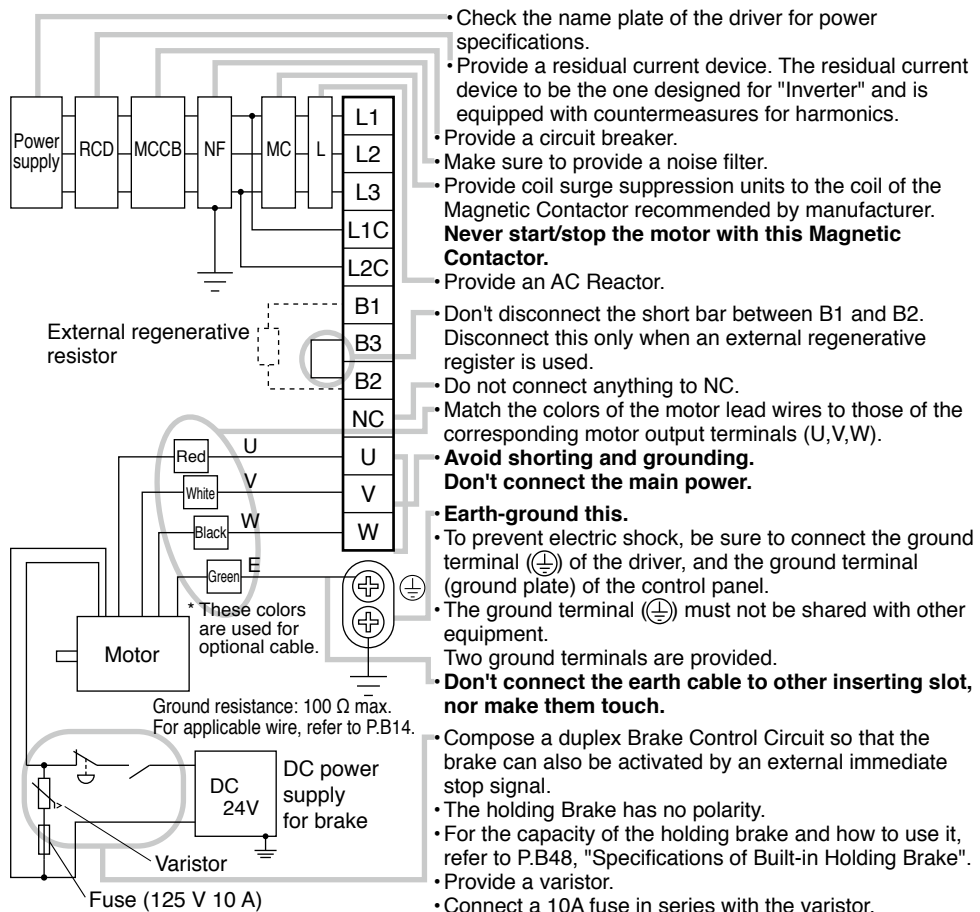

3. System Configuration and Wiring

Wiring method to connector

- Follow the procedures below for the wiring connection to the Connector [XA], [XB] and [XC].

How to connect

1. Peel off the insulation cover of the cable.
- For single wire (Please obey the length in figure.)

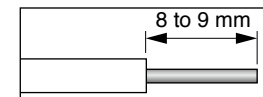

- For stranded wires (ferrules must be used as illustrated below).

Example: Ferrules with plastic insulating sleeve (AI series, Phoenix Contact, Ltd.)

- 1) Peel off the sheath so that the conductor portion of the cable will protrude from the tip of the ferrule. (It should protrude 1 mm or more from the ferrule.)
- 2) Insert the cable into the ferrule and crimp it with an appropriate crimping tool.
- 3) After crimping, cut off the cable conductor portion protruding from the ferrule. (The allowable protruding length after cutting should be 0 to 0.5 mm.)

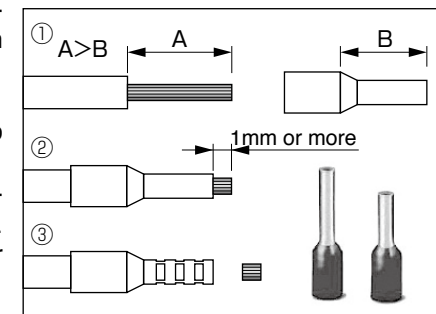

- Part No. of the crimping tool:

CRIMPFOX U-D66 (1204436) Available from Phoenix Contact, Ltd.

Examples: Nylon-insulated ferrule (NTUB series, J.S.T. Mfg. Co., Ltd.)

Vinyl-insulated ferrule (VTUB series, J.S.T. Mfg. Co., Ltd.)

- 1) Peel off the sheath of the cable conductor portion to the length equal to that of sheath on the ferrule.
- 2) Insert the cable into the ferrule and crimp it with an appropriate crimping tool.

- Part No. of the crimping tool: YNT-1614

Available from J.S.T. Mfg. Co., Ltd

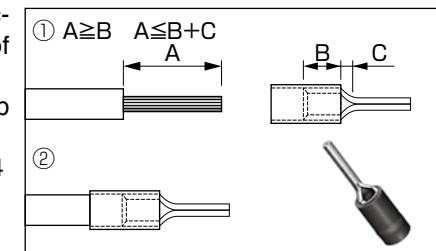

<Cables Compatible with Connector>

Conductor Size AWG18 to 12
Sheath Outline $\phi 2.1$ to $\phi 4.2$ mm

<Recommended Connector Bar Terminal>

Conductor Size AWG18
Terminal Model Number AI0.75-8GY (Phoenix Contact, Ltd.)
Conductor Size AWG16 to 14
Terminal Model Number VTUB-2 or NTUB-2 (J.S.T. Mfg. Co., Ltd)

Caution

- When peeling off the sheath of the cable, take care not to damage other portions.
- When crimping the ferrule, sufficiently check the status of the ferrule and cable. If the conductors of the cable stick out from the insulation cover or protrude excessively from the tip of the ferrule, accidents such as an electric shock and fire from a short circuit may result.

3. System Configuration and Wiring

Wiring method to connector

2. Insert the cable to the connector in the following 2 methods.

- (a) Insert the cable using the supplied handle lever.
- (b) Insert the cable using a flat-blade screwdriver (Edge width: 3.0 to 3.5 mm).

(a) Using handle lever

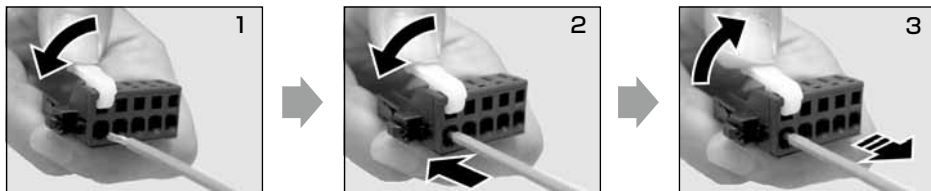

Attach the handle lever to the handling slot on the upper portion. Press down the lever to push down the spring.

Insert the peeled cable while pressing down the lever, until it hits the insertion slot (round hole).

Release the lever.

* You can pull out the cable by pushing down the spring as the above.

(b) Using screw driver

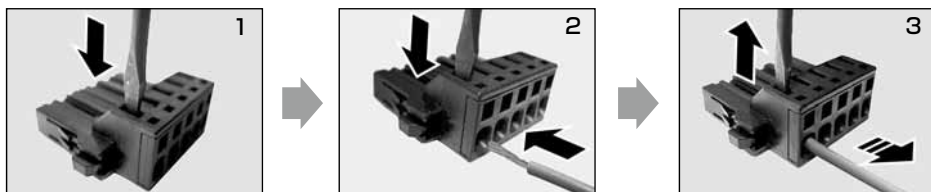

Press the screw driver to the handling slot on the upper portion to push down the spring.

Insert the peeled cable while pressing down the screw driver, until it hits the insertion slot (round hole).

Release the screw driver.

- Caution**
- Take off the connector from the Servo Driver before making connection.
 - Insert only one cable into each one of cable insertion slot.
 - Pay attention to injury by screw driver.

3. System Configuration and Wiring

Wiring Diagram

Compose the circuit so that the main circuit power will be shut off when an error occurs.

In Case of Single Phase, A to D-frame, 100 V / 200 V type

Power supply Single phase, 100V -15% to 120V +10% Single phase, 200V -15% to 240V +10%

Remarks

When you use single phase, connect the main power between L1 and L3 terminals.

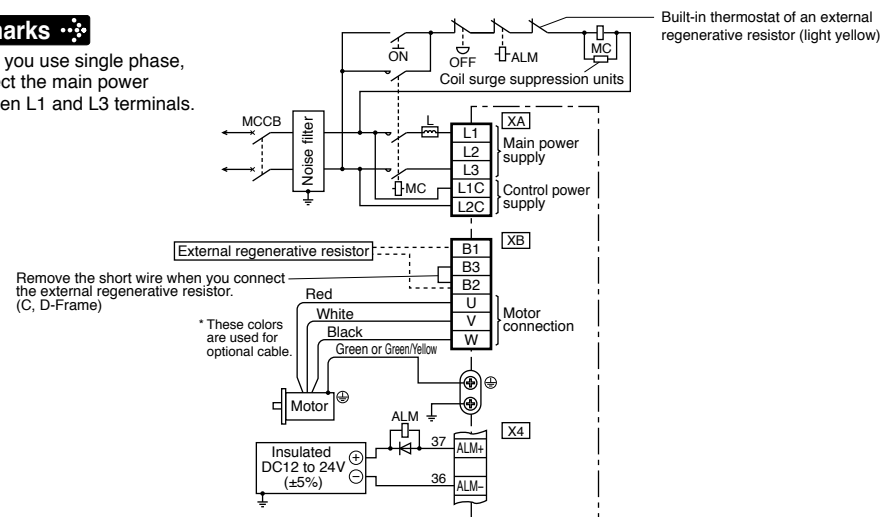

In Case of 3-Phase, A to D-frame, 200 V type

Power supply 3-phase, 200V -15% to 240V +10%

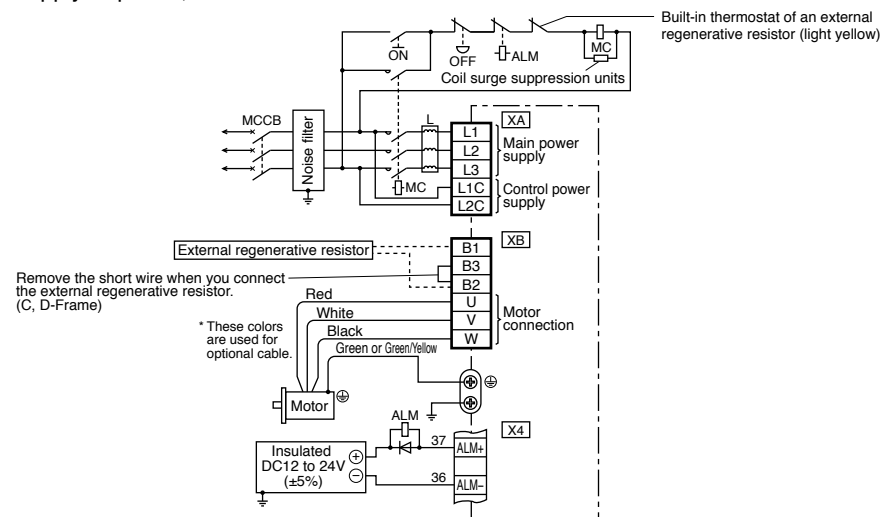

Note For wiring the motor connector, refer to P.B23.

3. System Configuration and Wiring

Wiring Diagram

Compose the circuit so that the main circuit power will be shut off when an error occurs.

In Case of 3-Phase, E-frame, 200 V type

Power supply 3-phase, 200V -15% to 230V +10%

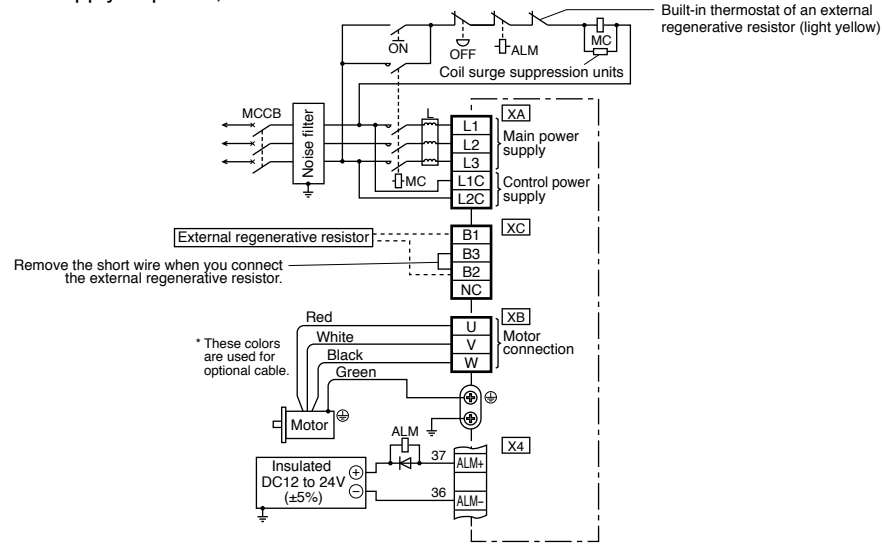

In Case of 3-Phase, F-frame, 200 V type

Power supply 3-phase, 200V -15% to 230V +10%

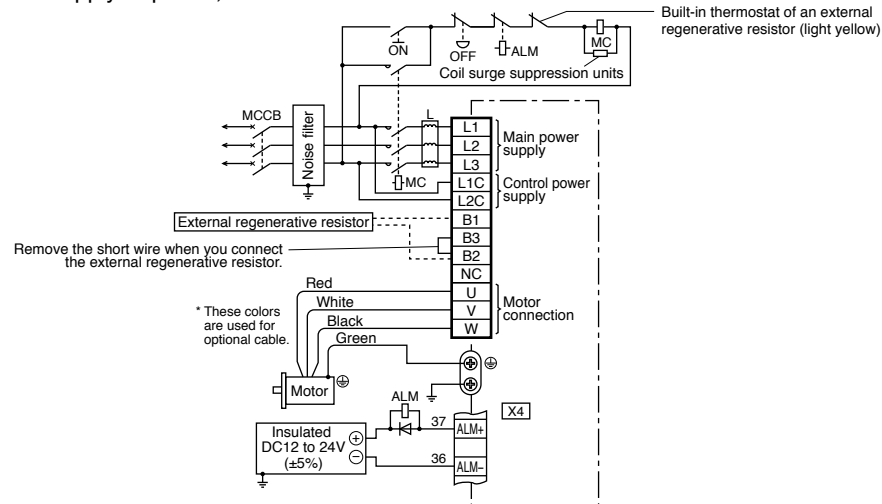

Note For wiring the motor connector, refer to P.B23.

3. System Configuration and Wiring

Wiring of connector for motor and brake

- When the motors of <MSME (50 W to 750 W)> are used, they are connected as shown below.

Connector: Made by Japan Aviation Electronics Industry, Ltd.

(The figures below show connectors for the motor.)

<Motor>

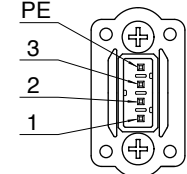

JN8AT04NJ1

PIN No.	Application
1	U-phase
2	V-phase
3	W-phase
PE	Ground

Tightening torque of the screw (M2)
0.085 to 0.095 N·m
(screwed to plastic)

<Brake>

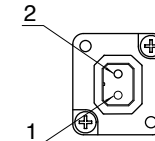

JN4AT02PJ1-R

PIN No.	Application
1	Brake
2	Brake

Tightening torque of the screw (M2)
0.19 to 0.21 N·m

- * Be sure to use only the screw supplied with the connector, to avoid damage.

- When the motors of <MSME (1.0 kW to 5.0 kW), MDME, MFME, MGME, MHME> are used, they are connected as shown below.

Connector: Made by Japan Aviation Electronics Industry, Ltd.

(The figures below show connectors for the motor.)

<without Brake>

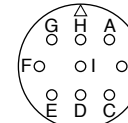

JL04V-2E20-18PE-B-R

PIN No.	Application
G	NC
H	NC
A	NC
F	U-phase
I	V-phase
B	W-phase
E	Ground
D	Ground
C	NC

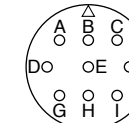

JL04V-2E24-11PE-B-R

PIN No.	Application
A	NC
B	NC
C	NC
D	U-phase
E	V-phase
F	W-phase
G	Ground
H	Ground
I	NC

<with Brake>

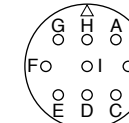

JL04V-2E20-18PE-B-R

PIN No.	Application
G	Brake
H	Brake
A	NC
F	U-phase
I	V-phase
B	W-phase
E	Ground
D	Ground
C	NC

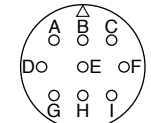

JL04V-2E24-11PE-B-R

PIN No.	Application
A	Brake
B	Brake
C	NC
D	U-phase
E	V-phase
F	W-phase
G	Ground
H	Ground
I	NC

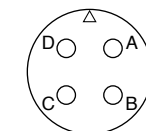

JL04V-2E20-4PE-B-R
JL04HV-2E22-22PE-B-R

PIN No.	Application
A	U-phase
B	V-phase
C	W-phase
D	Ground

Remarks

Do not connect anything to NC.

3. System Configuration and Wiring

Wiring to the connector, X1

This is used for USB connection to a personal computer. It is possible to change the parameter setting and perform monitoring.

Application	Symbol	Connector Pin No.	Contents
USB signal terminal	VBUS	1	Use for communication with personal computer.
	D-	2	
	D+	3	
	—	4	Do not connect.
	GND	5	Connected to ground of control circuit.

Caution Use commercially available USB mini-B connector for the driver.

3. System Configuration and Wiring

Wiring to the connector, X2

This is used for connection to the host controller when two or more units are used. RS232 and RS485 interfaces are supplied.

Application	Symbol	Connector Pin No.	Contents
Signal ground	GND	1	Connected to ground of control circuit.
NC	—	2	Do not connect.
RS232 signal	TXD	3	RS232
	RXD	4	The transmission / reception method.
RS485 signal	485-	5	RS485 The transmission / reception method.
	485+	6	
	485-	7	
	485+	8	
Frame ground	FG	Shell	Connected with protective earth terminal in the servo driver.

Connector (plug): 2040008-1 (optional, available from Tyco Electronics AMP)

[Connector pin assignment]



Remarks X1 to X7 are used for the secondary circuit. To connect these terminals to the primary power supply (particularly, the 24 VDC power supply for brake), insulation is required. Do not connect these terminals to the same power supply.

3. System Configuration and Wiring

Wiring to the connector, X3

A safety by-pass plug is supplied as standard equipment. Do not disconnect it in normal times.

When controlling the safety function from the connected host controller, accessory connector cannot be used. Prepare and wire the connector (option) as specified below. Since the standard connector cannot be used when controlling the safety function from the host controller, purchase the optional connector and make connection as shown below.

Application	Symbol	Connector Pin No.	Contents
NC	—	1	Do not connect.
	—	2	
Safety input 1	SF1-	3	These are two independent circuits that turn off the operation signal to the power module to shut off the motor current.
	SF1+	4	
Safety input 2	SF2-	5	
	SF2+	6	
EDM output	EDM-	7	This is an output for monitoring the failure of the safety function.
	EDM+	8	
Frame ground	FG	Shell	Connected with protective earth terminal in the servo driver.

Connector (plug): 2013595-1 (optional, available from Tyco Electronics AMP)

[Connector pin assignment]

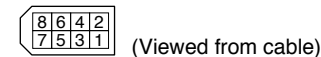

Remarks X1 to X7 are used for the secondary circuit. To connect these terminals to the primary power supply (particularly, the 24 VDC power supply for brake), insulation is required. Do not connect these terminals to the same power supply.

Caution Disconnecting this connector during operation results in immediate stop.

3. System Configuration and Wiring

Wiring to the connector, X4

Wiring Example of Position Control Mode

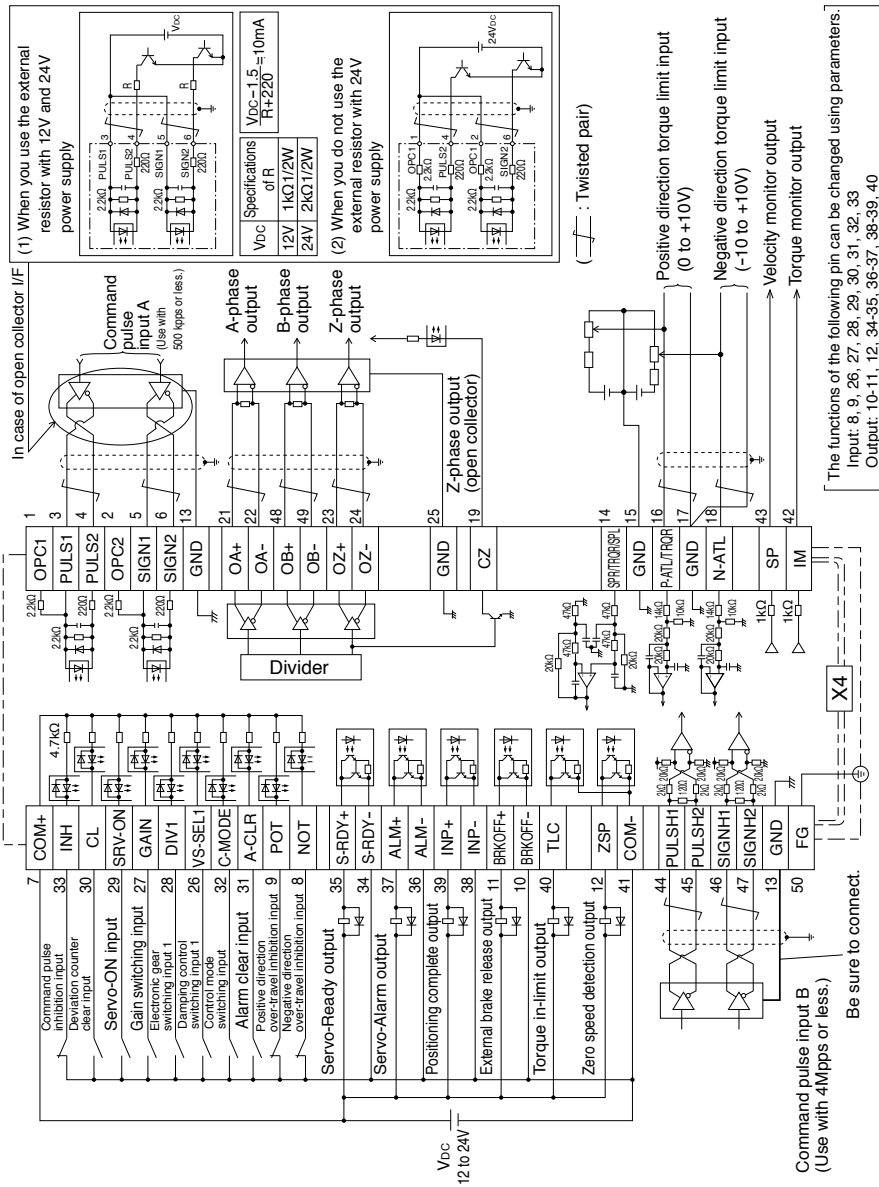

Remarks X1 to X7 are used for the secondary circuit. To connect these terminals to the primary power supply (particularly, the 24 VDC power supply for brake), insulation is required. Do not connect these terminals to the same power supply.

3. System Configuration and Wiring

Wiring to the connector, X4

Wiring Example of Velocity Control Mode

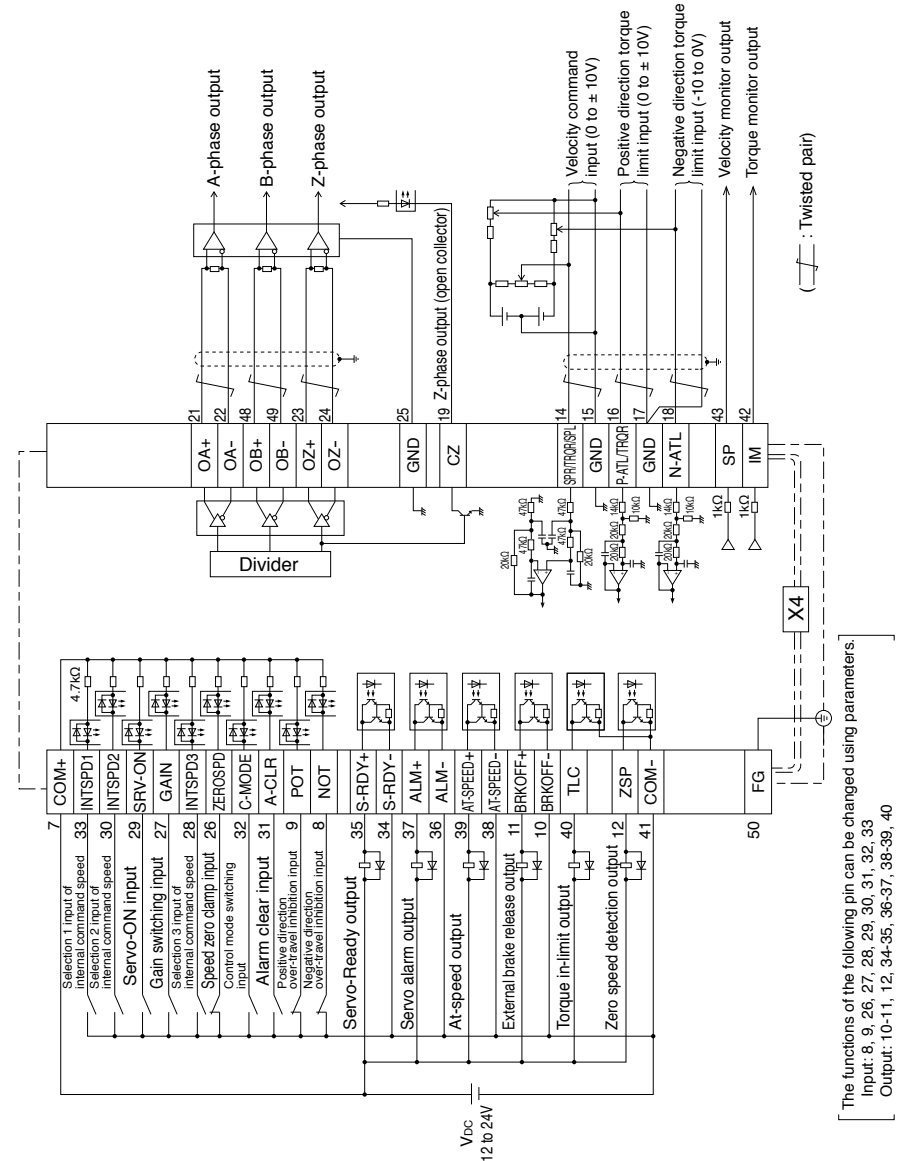

Remarks X1 to X7 are used for the secondary circuit. To connect these terminals to the primary power supply (particularly, the 24 VDC power supply for brake), insulation is required. Do not connect these terminals to the same power supply.

3. System Configuration and Wiring

Wiring to the connector, X4

Wiring Example of Torque Control Mode

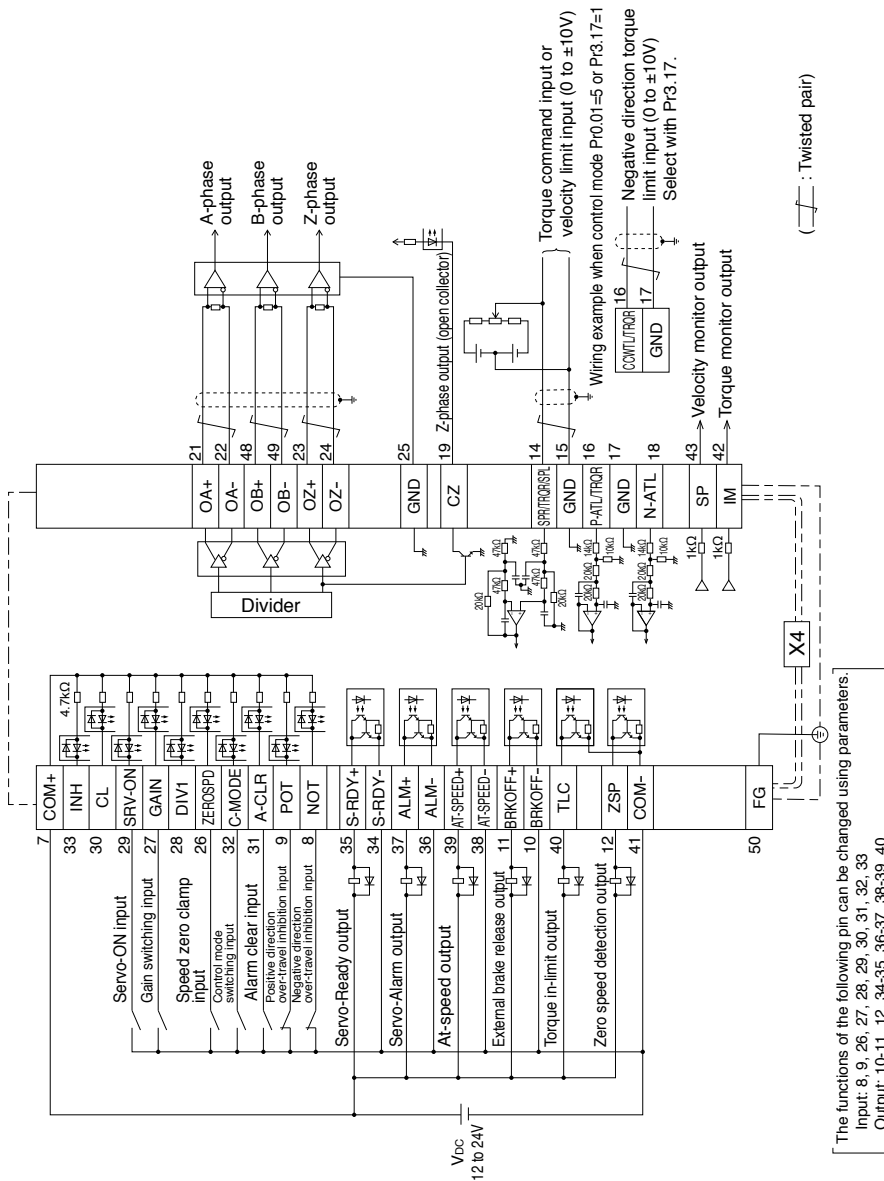

Remarks X1 to X7 are used for the secondary circuit. To connect these terminals to the primary power supply (particularly, the 24 VDC power supply for brake), insulation is required. Do not connect these terminals to the same power supply.

3. System Configuration and Wiring

Wiring to the connector, X5

Connect on to External Scale

Provide a power supply for the external scale on your part or use the following power output (250mA or less).

Application	Symbol	Connector Pin No.	Contents
Power supply output	EX5V	1	Supply the power of external scale or A, B, Z phase encoder.
	EX0V	2	Connected to ground of control circuit.
I/F of external scale signals	EXPS	3	Serial signal The transmission / reception method.
	/EXPS	4	
A, B, Z phase Encoder signal input	EXA	5	Parallel signal reception Correspondence speed : 4Mpps (after quadruple)
	/EXA	6	
	EXB	7	
	/EXB	8	
	EXZ	9	
	/EXZ	10	
Frame ground	FG	Shell	Connected with ground terminal in the servo driver.

Connector (plug): MUF-PK10K-X (by J.S.T. Mfg. Co., Ltd.)

• Caution

1) The manufacturers applicable external scales for this product are as follows.

- Mitutoyo Corp.
- Magnescale Co., Ltd.

For the details of the external scale product, contact each company.

2) **Recommended external scale ratio is $1/40 \leq \text{External scale ratio} \leq 160$**

If you set up the external scale ratio to smaller value than 50/position loop gain (Pr1.00 and Pr.1.05), you may not be able to control per 1 pulse unit. Setup of larger scale ratio may result in larger noise.

Remarks X1 to X7 are used for the secondary circuit. To connect these terminals to the primary power supply (particularly, the 24 VDC power supply for brake), insulation is required. Do not connect these terminals to the same power supply.

3. System Configuration and Wiring

Wiring to the connector, X6

Connection to Encoder

- In case of 20-bit incremental encoder

MSME 50W to 750W

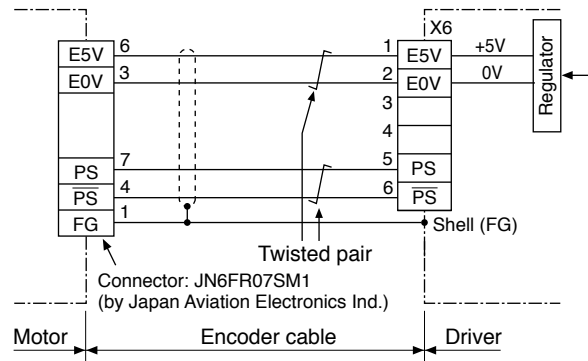

- Caution** ⚠
- Tighten the motor connector mounting screw (M2) [Connector pin assignment] with a torque between 0.19 and 0.21 N·m. To avoid damage, be sure to use only the screw supplied with the connector.
 - Do not remove the gasket supplied with the junction cable connector. Securely install the gasket in place. Otherwise, the degree of protection of IP67 will not be guaranteed.

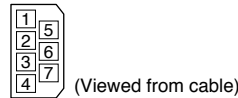

MSME 1.0kW to 5.0kW
 MDME 1.0kW to 5.0kW
 MFME 1.5kW to 4.5kW
 MGME 0.9kW to 4.5kW
 MHME 1.0kW to 5.0kW

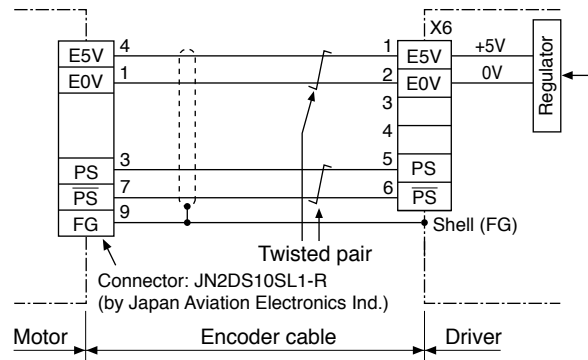

- Remarks** ⚠ X1 to X7 are used for the secondary circuit. To connect these terminals to the primary power supply (particularly, the 24 VDC power supply for brake), insulation is required. Do not connect these terminals to the same power supply.

3. System Configuration and Wiring

Wiring to the connector, X6

- In case of 17-bit absolute encoder

MSME 50W to 750W

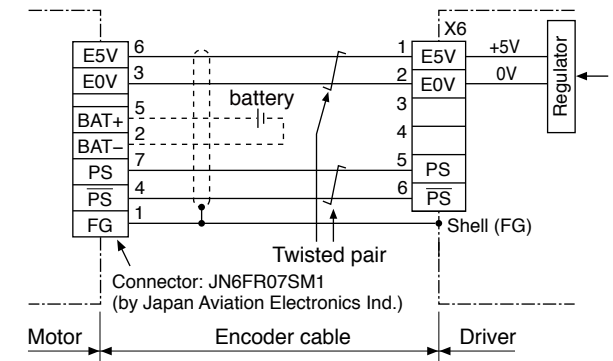

- Caution** ⚠
- Tighten the motor connector mounting screw (M2) [Connector pin assignment] with a torque between 0.19 and 0.21 N·m. To avoid damage, be sure to use only the screw supplied with the connector.
 - Do not remove the gasket supplied with the junction cable connector. Securely install the gasket in place. Otherwise, the degree of protection of IP67 will not be guaranteed.

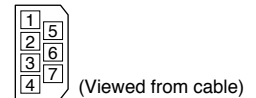

MSME 1.0kW to 5.0kW
 MDME 1.0kW to 5.0kW
 MFME 1.5kW to 4.5kW
 MGME 0.9kW to 4.5kW
 MHME 1.0kW to 5.0kW

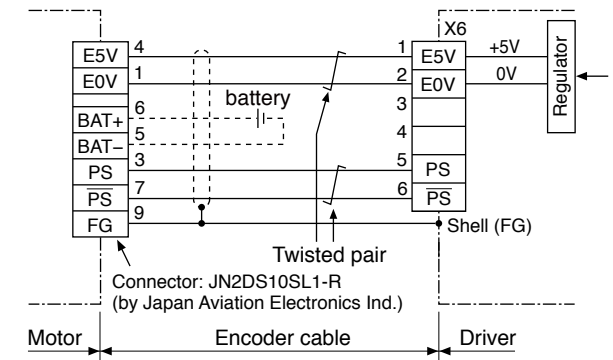

- Remarks** ⚠ X1 to X7 are used for the secondary circuit. To connect these terminals to the primary power supply (particularly, the 24 VDC power supply for brake), insulation is required. Do not connect these terminals to the same power supply.

3. System Configuration and Wiring

Wiring to the connector, X7

The connector X7 of the front panel is for monitor output.

Analogue output : 2 systems

Digital output : 1 systems

In both cases, it is possible to switch the output signal by setting parameters.

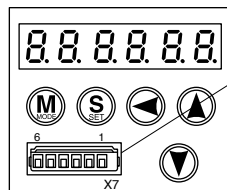

Connector X7
 Manufacturer's part No.:
 530140610
 Manufacturer:
 Japan Molex Inc.

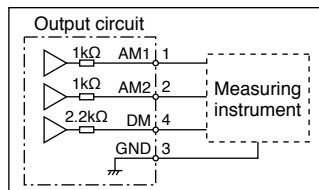

Application	Symbol	Connector Pin No.	Contents
Analogue monitor output 1	AM1	1	<ul style="list-style-type: none"> Output the analogue signal for monitor. The amplitude of the output signal is ± 10 V.
Analogue monitor output 2	AM2	2	<ul style="list-style-type: none"> Output impedance is 1 kΩ. When connecting a measuring instrument, check its input circuit for impedance matching.
Signal ground	GND	3	Connected to ground of control circuit.
Digital monitor output	DM	4	<ul style="list-style-type: none"> Output the digital signal for monitor. Output voltage is CMOS level compatible. Output impedance is 2.2 kΩ. When connecting a measuring instrument, check its input circuit for impedance matching.
NC	-	5	Do not connect.
NC	-	6	Do not connect.

Remarks X1 to X7 are used for the secondary circuit. To connect these terminals to the primary power supply (particularly, the 24 VDC power supply for brake), insulation is required. Do not connect these terminals to the same power supply.

4. Parameter

Outline / Setup / Connection

Outline of Parameter

This driver is equipped with various parameters to set up its characteristics and functions. This section describes the function and purpose of each parameter. Read and comprehend very well so that you can adjust this driver in optimum condition for your running requirements.

• You can refer and set up the parameter with either one of the following.

- 1) front panel of the driver
- 2) combination of the setup support software, "PANATERM" and PC.

Setup with the Front Panel

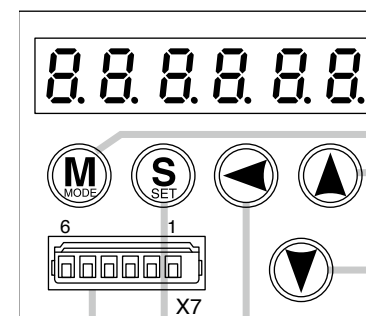

Display LED (6-digit)

Switch to error display screen when error occurs, and LED will flash (about 2Hz). LED will flash slowly (about 1Hz) when warning occurs.

Mode switching button

(valid at SELECTION display)
 Press this to switch 4 kinds of mode.

- 1) Monitor Mode
- 2) Parameter Set up Mode
- 3) EEPROM Write Mode
- 4) Auxiliary Function Mode

SET Button (valid at any time)

Press this to switch SELECTION and EXECUTION display.

Press these to change display and data, select parameters and execute actions. (Change/Selection/Execution is valid to the digit which decimal point flashes.)

Numerical value increases by pressing \blacktriangle , decreases by pressing \blacktriangledown .

X7
 Output connector for monitor

Shifting of the digit for data changing to higher digit.

4. Parameter

Outline / Setup / Connection

Setup with the PC

It is possible to connect your personal computer to connector X1 of MINAS A5 using a USB cable for personal computer connection. Downloading the setup support software "PANATERM" from our web site and installing it on your personal computer will allow you to perform the following easily.

• With the PANATERM, you can execute the followings.

- 1) Setup and storage of parameters, and writing to the memory (EEPROM).
- 2) Monitoring of I/O, pulse input and load factor.
- 3) Display of the present alarm and reference of the error history.
- 4) Data measurement of the wave-form graphic and bringing of the stored data.
- 5) Normal auto-gain tuning
- 6) Frequency characteristic measurement of the machine system.

Note Because no production software such as CD-ROM is available, download the setup support software from our web site and install it on your personal computer.

• How to Connect

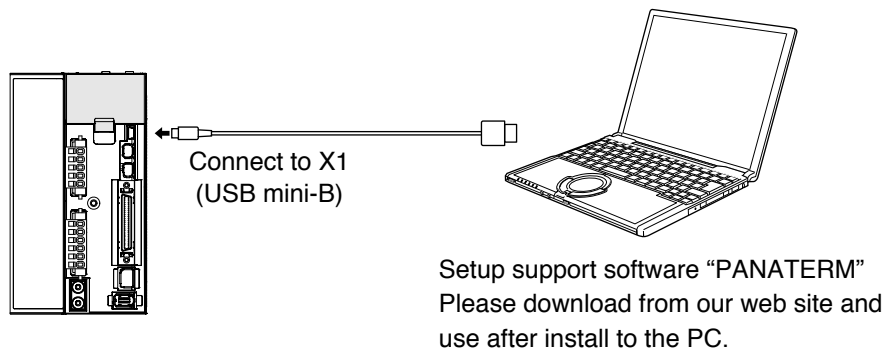

• USB cable

On the driver, use commercially available USB mini-B connector.
The connector on the personal computer side should be in accordance with the specifications of the PC.
When the cable does not have noise filter, attach a signal line noise filter (DV0P1460) to both ends of the cable.

4. Parameter

Composition of Parameters

- The parameter No. is displayed in the form of PrX.YY (X: Classification, YY: No.).
- For the details on the parameters, refer to the Operating Instructions (Overall).

Parametr No.		Class name	Group
Class	No.*		
0	00 to	Basic setting	Parameter for Basic setting
1	00 to	Gain adjustment	Parameter for Gain adjustment
2	00 to	Damping control	Parameter for Damping control
3	00 to	Verocity/ Torque/ Full-closed control	Parameter for Verocity/ Torque/ Full-closed control
4	00 to	I/F monitor setting	Parameter for I/F monitor setting
5	00 to	Enhancing setting	Parameter for Enhancing setting
6	00 to	Special setting	Parameter for Special setting

* The Parameter No. consists of 2 digits.

5. Protective Functions

Protective Function (What Is Error Code ?)

- Various protective functions are equipped in the driver. When these are triggered, the motor will stall due to error, the driver will turn the Servo-Alarm output (ALM) to off (open).
- Error status and their measures
 - During the error status, the error code No. will be displayed on the front panel LED, and you cannot turn Servo-ON.
 - You can clear the error status by Alarm clear input(A-CLR) in 120ms or longer.
 - When overload protection is triggered, you can clear it by Alarm clear input(A-CLR) in 10sec or longer after the error occurs. You can clear the Overload protection time characteristics (refer to P.B40, 41) by turning off the control power supply between L1C and L2C (100V, 200V) of the driver.*1
 - You can clear the above error by operating the front panel keys and setup support software "PANATERM".
 - Be sure to clear the alarm during stop after removing the cause of the error and securing safety.
- **The error code No. is displayed in the form of ErrXX.Y (X: main, YY: sub).**

<List of error code No.>

Error code		Protective function	Attribute		
Main	Sub		History	Can be cleared	Immediate stop
11	0	Control power supply under- voltage protection		○	
12	0	Over-voltage protection	○	○	
13	0	Main power supply under-voltage protection (between P to N)		○	
	1	Main power supply under-voltage protection (AC interception detection)		○	
14	0	Over-current protection	○		
	1	IPM error protection	○		
15	0	Over-heat protection	○		○
16	0	Over-load protection	○	○*1	
18	0	Over-regeneration load protection	○		○
	1	Over-regeneration Tr error protection	○		
21	0	Encoder communication disconnect error protection	○		
	1	Encoder communication error protection	○		
23	0	Encoder communication data error protection	○		
24	0	Position deviation excess protection	○	○	○
25	0	Hybrid deviation excess error protection	○		○
26	0	Over-speed protection	○	○	○
	1	2nd over-speed protection	○	○	
27	0	Command pulse input frequency error protection	○	○	○
	2	Command pulse multiplier error protection	○	○	○
28	0	Limit of pulse replay error protection	○	○	○
29	0	Deviation counter overflow protection	○	○	
30	0	Safety detection		○	
33	0	IF overlaps allocation error 1 protection	○		
	1	IF overlaps allocation error 2 protection	○		
	2	IF input function number error 1 protection	○		

5. Protective Functions

Protective Function (What Is Error Code ?)

Error code		Protective function	Attribute		
Main	Sub		History	Can be cleared	Immediate stop
33	3	IF input function number error 2 protection	○		
	4	IF output function number error 1 protection	○		
	5	IF output function number error 2 protection	○		
	6	CL fitting error protection	○		
	7	INH fitting error protection	○		
34	0	Software limit protection	○	○	
36	0 to 2	EEPROM parameter error protection			
37	0 to 2	EEPROM check code error protection			
38	0	Over-travel inhibit input protection		○	
39	0	Analog input1 excess protection	○	○	○
	1	Analog input2 excess protection	○	○	○
	2	Analog input3 excess protection	○	○	○
40	0	Absolute system down error protection	○	○	
41	0	Absolute counter over error protection	○		
42	0	Absolute over-speed error protection	○	○	
43	0	Initialization failure	○		
44	0	Absolute single turn counter error protection	○		
45	0	Absolute multi-turn counter error protection	○		
47	0	Absolute status error protection	○		
48	0	Encoder Z-phase error protection	○		
49	0	Encoder CS signal error protection	○		
50	0	Feedback scale connection error protection	○		
	1	Feedback scale communication error protection	○		
51	0	Feedback scale status 0 error protection	○		
	1	Feedback scale status 1 error protection	○		
	2	Feedback scale status 2 error protection	○		
	3	Feedback scale status 3 error protection	○		
	4	Feedback scale status 4 error protection	○		
	5	Feedback scale status 5 error protection	○		
55	0	A-phase connection error protection	○		
	1	B-phase connection error protection	○		
	2	Z-phase connection error protection	○		
87	0	Compulsory alarm input protection		○	
95	0	Motor automatic recognition error protection			
Other number		Other error	○		

Note

History...The error will be stored in the error history.

Can be cleared...To cancel the error, use the alarm clear input (A-CLR).

If the alarm clear input is not effective, turn off power, remove the cause of the error and then turn on power again.

Immediate stop...Instantaneous controlled stop upon occurrence of an error. (Setting of "Pr.5.10 Sequence at alarm" is also required.)

6. Maintenance and Inspections

Maintenance and Inspections

- Routine maintenance and inspection of the driver and motor are essential for the proper and safe operation.

Notes on Maintenance and Inspection

- 1) Turn on and turn off should be done by operators or inspectors themselves.
- 2) Internal circuit of the driver is kept charged with high voltage for a while even after power-off. Turn off the power and allow 15 minutes or longer after LED display of the front panel has gone off, before performing maintenance and inspection.
- 3) Disconnect all of the connection to the driver when performing megger test (Insulation resistance measurement) to the driver, otherwise it could result in breakdown of the driver.
- 4) Do not use benzine, thinner, alcohol, acidic cleaner and alkaline cleaner because they can discolor or damage the exterior case.

Inspection Items and Cycles

General and normal running condition

Ambient conditions : 30°C (annual average), load factor of 80% or lower, operating hours of 20 hours or less per day.

Perform the daily and periodical inspection as per the items below.

Type	Cycles	Items to be inspected
Daily inspection	Daily	<ul style="list-style-type: none"> • Ambient temperature, humidity, speck, dust or foreign object • Abnormal vibration and noise • Main circuit voltage • Odor • Lint or other particles at air holes • Cleanness at front portion of the driver and connector • Damage of the cables • Loose connection or misalignment between the motor and machine or equipment • Pinching of foreign object at the load
Periodical inspection	Annual	<ul style="list-style-type: none"> • Loose tightening • Trace of overheat • Damage to the terminal block • Loose fasteners on terminal block

Note Inspection cycle may change when the running conditions of the above change.

6. Maintenance and Inspections

Maintenance and Inspections

Guideline for Parts Replacement

Use the table below for a reference. Parts replacement cycle varies depending on the actual operating conditions. Defective parts should be replaced or repaired when any error have occurred.

 Prohibited	Disassembling for inspection and repair should be carried out only by authorized dealers or service company.
--	---

Product	Component	Standard replacement cycles (hour)	Note
Driver	Smoothing condenser	Approx. 5 years	These hours or cycles are reference. When you experience any error, replacement is required even before this standard replacement cycle.
	Cooling fan	2 to 3 years (10,000 to 30,000 hours)	
	Aluminum electrolytic capacitor (on PCB)	Approx. 5 years	
	Rush current preventive relay	Approx. 100,000 times (depending on working condition)	
	Rush current preventive resistor	Approx. 20,000 times (depending on working condition)	
Motor	Bearing	3 to 5 years (20,000 to 30,000 hours)	
	Oil seal	5000 hours	
	Encoder	3 to 5 years (20,000 to 30,000 hours)	
	Battery for absolute encoder	Life time varies depending on working conditions. Refer to the Operating Instructions attached to the battery for absolute encoder.	

7. Conformity to EC Directives and UL Standards

EC Directives / Conformity to UL Standards

EC Directives

The EC Directives apply to all such electronic products as those having specific functions and have been exported to EU and directly sold to general consumers. Those products are required to conform to the EU unified standards and to furnish the CE marking on the products.

However, our AC servos meet the relevant EC Directives for Low Voltage Equipment so that the machine or equipment comprising our AC servos can meet EC Directives.

EMC Directives

MINAS Servo System conforms to relevant standard under EMC Directives setting up certain model (condition) with certain locating distance and wiring of the servo motor and the driver. And actual working condition often differs from this model condition especially in wiring and grounding. Therefore, in order for the machine to conform to the EMC Directives, especially for noise emission and noise terminal voltage, it is necessary to examine the machine incorporating our servos.

Conformity to UL Standards

Observe the following conditions of (1) and (2) to make the system conform to UL508C (File No. E164620).

- (1) Use the driver in an environment of Pollution Degree 2 or 1 prescribed in IEC60664-1. (e.g. Install in the control box with IP54 enclosure.)
- (2) Make sure to install a circuit breaker or fuse which are UL recognized (Listed UL marked) between the power supply and the noise filter.
For the rated current of the circuit breaker or fuse, refer to P.B14, "Driver and List of Applicable Peripheral Equipments" of Preparation.
Use a copper cable with temperature rating of 75°C or higher.
- (3) Over-load protection level
Over-load protective function will be activated when the effective current exceeds 115% or more than the rated current based on the time characteristics (see the next page). Confirm that the effective current of the driver does not exceed the rated current. Set up the peak permissible current with Pr0.13 (Setup of 1st torque limit) and Pr5.22 (Setup 2nd torque limit).
- (4) Motor over-temperature protection is not provided.
Motor over-load-temperature protection shall be provided at the final installation upon required by the NEC (National Electric Code).

7. Conformity to EC Directives and UL Standards

EC Directives / Conformity to UL Standards

Overload protection time characteristics

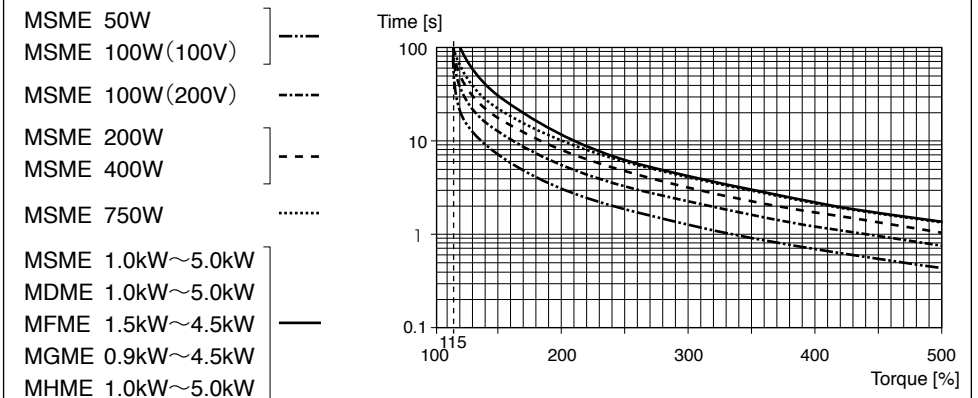

Conformed Standards

		Driver	Motor
EC Directives	EMC Directives	EN55011 EN61000-6-2 EN61800-3	-
	Low-Voltage Directives	EN61800-5-1	IEC60034-1 IEC60034-5
	Functional safety	EN954-1 (Cat. 3) ISO13849-1 (PL c, d*)(Cat. 3) EN61508 (SIL 2) EN62061 (SIL 2) EN61800-5-2 (STO) IEC61326-3-1	-
UL Standards	UL508C (File No.E164620)	UL1004-1 (E327868 : 50W to 750W) UL1004 (E327868 : 0.9kW to 5.0kW)	
CSA Standards	C22.2 No.14	C22.2 No.100	

IEC : International Electrotechnical Commission
 EN : Europaischen Normen
 EMC : Electromagnetic Compatibility
 UL : Underwriters Laboratories
 CSA : Canadian Standards Association

Pursuant to the directive 2004/108/EC, article 9(2)
 Panasonic Testing Centre
 Panasonic Service Europe, a division of
 Panasonic Marketing Europe GmbH
 Winsbergring 15, 22525 Hamburg, F.R. Germany

* PL d: Provided that EDM is used.

7. Conformity to EC Directives and UL Standards

Composition of Peripheral Equipments

Installation Environment

Use the servo driver in the environment of Pollution Degree 1 or 2 prescribed in IEC-60664-1 (e.g. Install the driver in control panel with IP54 protection structure.)

Metallic control box

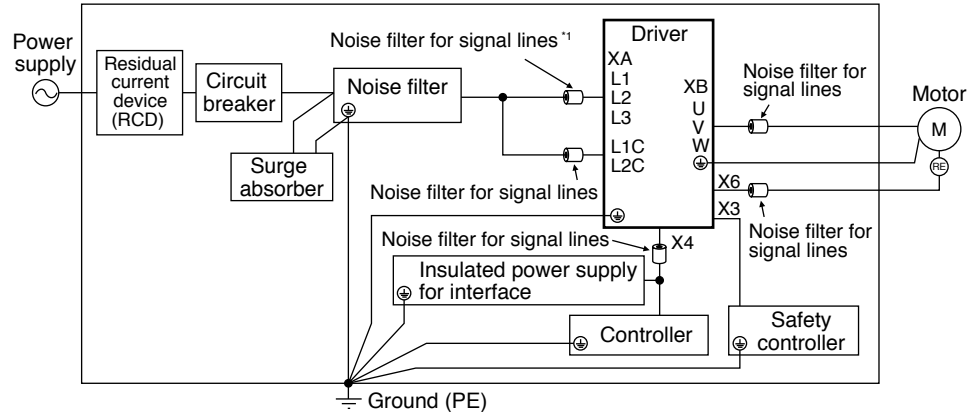

*1 A to D-frame: Noise filter for signal lines, E, F-frame: Noise filter for signal lines <Power supply cable>

Caution Use options correctly after reading Operating Instructions of the options to better understand the precautions. Take care not to apply excessive stress to each optional part.

Power Supply

100V type : Single phase, (A to C-frame)	100V	+10% -15%	to	120V	+10% -15%	50/60Hz
200V type : Single/3-phase, (A to D-frame)	200V	+10% -15%	to	240V	+10% -15%	50/60Hz
200V type : 3-phase, (E, F-frame)	200V	+10% -15%	to	230V	+10% -15%	50/60Hz

- (1) This product is designed to be used in over-voltage category (installation category) III of EN 61800-5-1:2007.
- (2) Use an insulated power supply of DC12 to 24V which has CE marking or complies with EN60950.

Circuit Breaker

Install a circuit breaker which complies with IEC Standards and UL recognized (Listed and marked) between power supply and noise filter. Integral solid state short circuit protection does not provide branch circuit protection. Branch circuit protection must be provided in accordance with the National Electrical Code and any additional local codes.

7. Conformity to EC Directives and UL Standards

Composition of Peripheral Equipments

Noise Filter

When you install one noise filter at the power supply for multi-axes application, consult with manufacturer of the noise filter. If sufficient noise margin is required, connect 2 filters in series.

• Optional parts

Option part No.	Voltage specifications for driver	Manufacturer's part No.	Applicable driver (frame)	Manufacturer
DV0P4170	Single phase 100V/200V	SUP-EK5-ER-6	A and B-frame	Okaya Electric Ind.

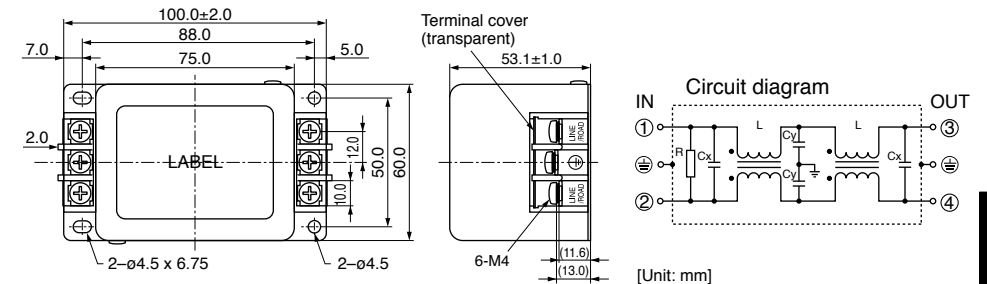

Option part No.	Voltage specifications for driver	Manufacturer's part No.	Applicable driver (frame)	Manufacturer
DV0PM20042	3-phase 200V	3SUP-HU10-ER-6	A, B-frame	Okaya Electric Ind.
DV0P4220	Single phase 100V/200V		C-frame	
DV0P4220	3-phase 200V	3SUP-HU30-ER-6	D-frame	
DV0PM20043	3-phase 200V	3SUP-HU50-ER-6	E-frame	

<DV0PM20042, DV0P4220>

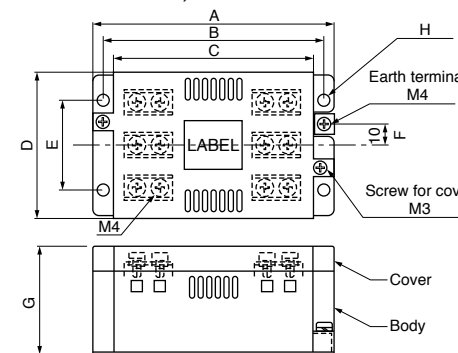

<DV0PM20043>

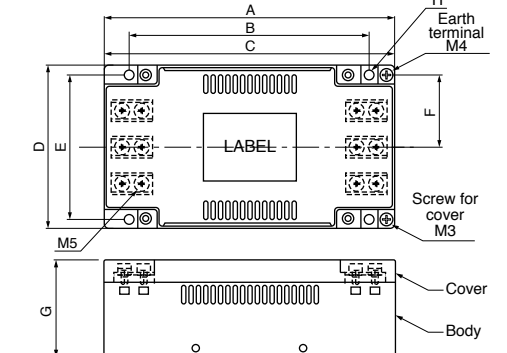

[Size]	[Unit: mm]	A	B	C	D	E	F	G	H
DV0PM20042		115	105	95	70	43	10	52	5.5
DV0P4220		145	135	125	70	50	10	52	5.5
DV0PM20043		165	136	165	90	80	40	54	5.5

For single phase application, use 2 terminals among 3 terminals, leaving the remaining terminal unconnected.

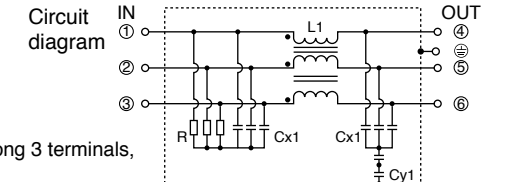

7. Conformity to EC Directives and UL Standards

Composition of Peripheral Equipments

Option part No.	Voltage specifications for driver	Manufacturer's part No.	Applicable driver (frame)	Manufacturer
DV0P3410	3-phase 200V	3SUP-HL50-ER-6B	F-frame	Okaya Electric Ind.

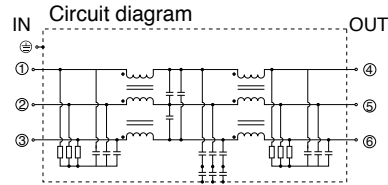
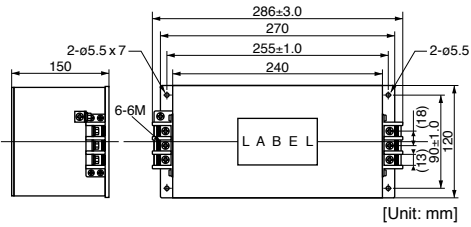

Recommended components

Model No.	Voltage specifications for driver	Current rating (A)	Applicable driver (frame)	Manufacturer
RTHN-5010	Single phase 100V/200V 3-phase 200V	10	A, B, C-frame	TDK-Lambda Corp.
RTHN-5030		30	D-frame	
RTHN-5050		50	E, F-frame	

<RTHN-5010>

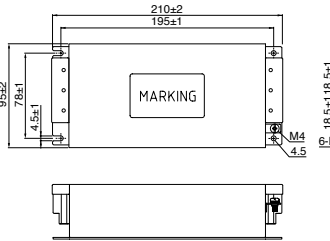

<RTHN-5030>

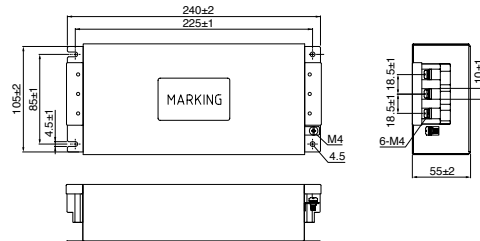

<RTHN-5050>

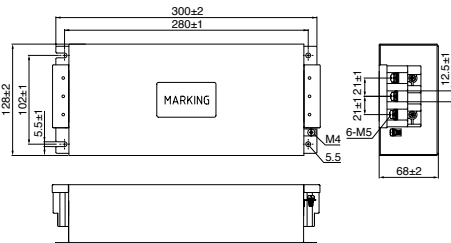

Remarks

- Select a noise filter whose capacity is commensurate with the power source capacity (in consideration of the load condition).
- For the detailed specifications of each noise filter, contact the manufacturer.

7. Conformity to EC Directives and UL Standards

Composition of Peripheral Equipments

Surge Absorber

Provide a surge absorber for the primary side of noise filter.

Option part No.	Voltage specifications for driver	Manufacturer's part No.	Manufacturer
DV0P1450	3-phase 200V	R·A·V-781BXZ-4	Okaya Electric Ind.

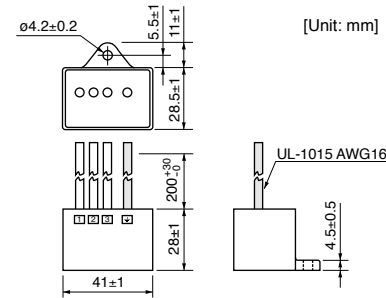

Circuit diagram

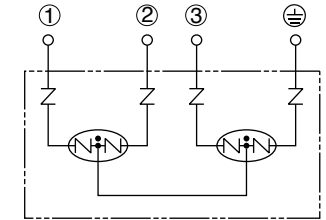

Option part No.	Voltage specifications for driver	Manufacturer's part No.	Manufacturer
DV0P4190	Single phase 100V/200V	R·A·V-781BWZ-4	Okaya Electric Ind.

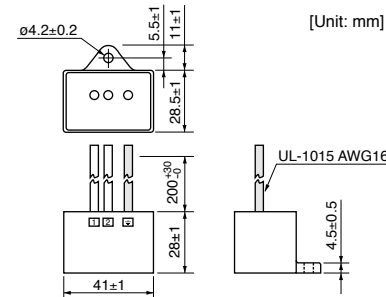

Circuit diagram

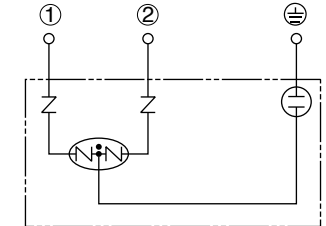

7. Conformity to EC Directives and UL Standards

Composition of Peripheral Equipments

Noise Filter for Signal Lines

Install noise filters for signal lines to all cables (power cable, motor cable, encoder cable and interface cable)

• Optional parts

<24V Power cable, Encoder cable, Interface cable and USB cable>

Option part No.	Manufacturer's part No.	Manufacturer
DV0P1460	ZCAT3035-1330	TDK Corp.

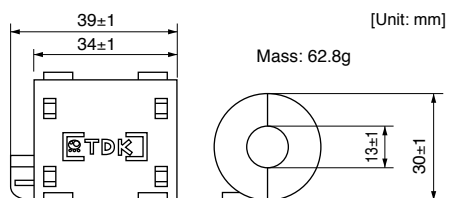

Remarks ❖ To connect the noise filter to the connector XB connection cable, adjust the sheath length at the tip of the cable, as required.

Caution ❖ Fix the signal line noise filter in order to prevent excessive stress to the cables.

• Recommended components

<Power cable>

Manufacturer's part No.	Manufacturer
RJ8035	KK-CORP.CO.JP

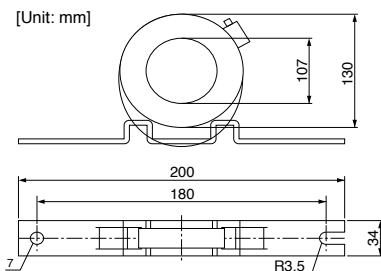

7. Conformity to EC Directives and UL Standards

Composition of Peripheral Equipments

Residual current device

Install a type B Residual current device (RCD) at primary side of the power supply.

Grounding

- (1) To prevent electric shock, be sure to connect the ground terminal (⊕) of the driver, and the ground terminal (PE) of the control panel.
- (2) The ground terminal (⊕) must not be shared with other equipment. Two ground terminals are provided.

Note ❖ For driver and applicable peripheral equipments, refer to P.B12 "Driver and List of Applicable Peripheral Equipments" .

8. Built-in Holding Brake

Outline / Specifications

In the applications where the motor drives the vertical axis, this brake would be used to hold and prevent the work (moving load) from falling by gravity while the power to the servo is shut off.

Use this built-in brake for "Holding" purpose only, that is to hold the stalling status. Never use this for "Brake" purpose to stop the load in motion.

Output Timing of BRK-OFF Signal

- For the brake release timing at power-on, or braking timing at Servo-OFF/Servo-Alarm while the motor is in motion, refer to the Operating Instructions (Overall).
- With the parameter, Pr4.38 (Setup of mechanical brake action while the motor is in motion), you can set up a time between when the motor enters to a free-run from energized status and when BRK-OFF signal turns off (brake will be engaged), when the Servo-OFF or alarm occurs while the motor is in motion. Refer to the Operating Instructions (Overall) for the details.

- Note**
1. The lining sound of the brake (chattering and etc.) might be generated while running the motor with built-in brake, however this does not affect any functionality.
 2. Magnetic flux might be generated through the motor shaft while the brake coil is energized (brake is open). Pay an extra attention when magnetic sensors are used nearby the motor.

8. Built-in Holding Brake

Outline / Specifications

Specifications of Built-in Holding Brake

Motor series	Motor output	Static friction torque N·m	Rotor inertia x 10 ⁻⁴ kg·m ²	Engaging time ms	Releasing time ms	Exciting current DC A (at cool-off)	Releasing voltage	Permissible work (J) per one braking	Permissible total work x 10 ³ J	Permissible angular acceleration rad/s ²
MSME	50W, 100W	0.29 or more	0.002	35 or less	20 or less	0.3	DC1V or more	39.2	4.9	30000
	200W, 400W	1.27 or more	0.018	50 or less	15 or less	0.36		137	44.1	
	750W	2.45 or more	0.075	70 or less	20 or less	0.42		196	147	
	1.0kW, 1.5kW, 2.0kW	7.8 or more	0.33	50 or less	15 or less (100)	0.81	DC2V or more	392	490	10000
	3.0kW	11.8 or more		80 or less						
4.0kW, 5.0kW	16.2 or more	1.35	110 or less	50 or less (130)	0.9	1470	2200			
MDME	1.0kW	4.9 or more	1.35	80 or less	70 or less (200)	0.59	DC2V or more	588	780	10000
	1.5kW, 2.0kW	13.7 or more		100 or less	50 or less (130)	0.79		1176	1500	
	3.0kW	16.2 or more		110 or less	0.9	1470		2200		
	4.0kW, 5.0kW	24.5 or more	4.7	80 or less	25 or less (200)	1.3		1372	2900	
MFME	1.5kW	7.8 or more	4.7	80 or less	35 or less	0.83	DC2V or more	1372	2900	10000
	2.5kW	21.6 or more	8.75	150 or less	100 or less	0.75		1470	1500	
	4.5kW	31.4 or more						2200		
MGME	900W	13.7 or more	1.35	100 or less	50 or less (130)	0.79	DC2V or more	1176	1500	10000
	2.0kW	24.5 or more	4.7	80 or less	25 or less (200)	1.3		1372	2900	5440
	3.0kW	58.8 or more		150 or less	50 or less (130)	1.4				
	4.5kW									
MHME	1.0kW	4.9 or more	1.35	80 or less	70 or less (200)	0.59	DC2V or more	588	780	10000
	1.5kW	13.7 or more		100 or less	50 or less (130)	0.79		1176	1500	
	2.0kW to 5.0kW	24.5 or more	4.7	80 or less	25 or less (200)	1.3		1372	2900	

- Excitation voltage is DC24V±10%.
- Releasing time values represent the ones with DC-cutoff using a varistor. Values in () represent those measured by using a diode (V03C by Hitachi, Ltd.)
- Above values (except static friction torque, releasing voltage and excitation current) represent typical values.
- Backlash of the built-in holding brake is kept ±1° or smaller at ex-factory point.
- Service life of the number of acceleration/deceleration with the above permissible angular acceleration is more than 10 million times. (Life end is defined as when the brake backlash drastically changes.)

9. Dynamic Brake

Outline

This driver is equipped with a dynamic brake for emergency stop. Pay a special attention to the followings.

Caution 1. Dynamic brake is only for emergency stop.

Do not start/stop the motor by turning on/off the Servo-ON signal (SRV-ON). Otherwise it may damage the dynamic brake circuit of the driver.

The Motor becomes a dynamo when driven externally and short circuit current occurred while dynamic brake is activated may cause smoking or fire.

2. Dynamic brake is a short-duration rating, and designed for only emergency stop. Allow approx. 10 minutes pause when the dynamic brake is activated during high-speed running.

(F-frame(200V) built-in dynamic brake resistor is capable of handling up to 3 continuous halts at the rated revolutions with max. permissible inertia. When overheated under more critical operating conditions, the brake will blow out and should be replaced with a new one.)

• **You can activate the dynamic brake in the following cases.**

- 1) when the main power is turned off
- 2) at Servo-OFF
- 3) when one of the protective function is activated.
- 4) when over-travel inhibit input (NOT, POT) of connector X4 is activated

In the above cases from 1) to 4), you can select either activation of the dynamic brake or making the motor free-run during deceleration or after the stop, with parameter.

10. Check of the Combination of the Driver and the Motor

Incremental Specifications, 20-bit

This driver is designed to be used in a combination with the motor which are specified by us. Check the series name of the motor, rated output torque, voltage specifications and encoder specifications.

Caution Do not use in other combinations than those listed below.

		Motor			Driver					
Power supply	Type	Rated rotational speed	Model	Rated output	Model	Frame				
Single phase, 100V	MSME Low inertia	3000r/min	MSME5AZG1*	50W	MADHT1105	A-frame				
			MSME011G1*	100W	MADHT1107					
			MSME021G1*	200W	MBDHT2110	B-frame				
			MSME041G1*	400W	MCDHT3120	C-frame				
Single/ 3-phase, 200V			MSME Low inertia	3000r/min	MSME5AZG1*	50W	MADHT1505	A-frame		
					MSME012G1*	100W	MADHT1507			
					MSME022G1*	200W	MADHT1507	B-frame		
					MSME042G1*	400W	MBDHT2510	B-frame		
3-phase, 200V					MSME Low inertia	3000r/min	MSME082G1*	750W	MCDHT3520	C-frame
							MSME102G□*	1.0kW	MDDHT5540	D-frame
							MSME152G□*	1.5kW		
							MSME202G□*	2.0kW	MEDHT7364	E-frame
3-phase, 200V	MSME Low inertia	3000r/min					MSME302G□*	3.0kW	MFDHTA390	F-frame
							MSME402G□*	4.0kW	MFDHTB3A2	
							MSME502G□*	5.0kW		
							Single/3-phase, 200V	MDME Middle inertia	2000r/min	MDME102G□*
MDME152G□*			1.5kW	MDDHT5540						E-frame
MDME202G□*			2.0kW	MEDHT7364						
MDME302G□*			3.0kW	MFDHTA390						F-frame
MDME402G□*			4.0kW	MFDHTB3A2						
MDME502G□*			5.0kW							
Single/3-phase, 200V			MFME Middle inertia	2000r/min	MFME152G1*	1.5kW	MDDHT5540	D-frame		
					MFME252G1*	2.5kW	MEDHT7364	E-frame		
					MFME452G1*	4.5kW	MFDHTB3A2	F-frame		
Single/3-phase, 200V	MGME Middle inertia	1000r/min	MGME092G□*	900W	MDDHT5540	D-frame				
			MGME202G□*	2.0kW	MFDHTA390	F-frame				
			MGME302G□*	3.0kW	MFDHTB3A2					
			MGME452G1*	4.5kW						
Single/3-phase, 200V	MHME High inertia	2000r/min	MHME102G□*	1.0kW	MDDHT3530	D-frame				
			MHME152G□*	1.5kW	MDDHT5540	E-frame				
			MHME202G□*	2.0kW	MEDHT7364					
			MHME302G□*	3.0kW	MFDHTA390	F-frame				
			MHME402G□*	4.0kW	MFDHTB3A2					
			MHME502G□*	5.0kW						

Note • Suffix of “□” in the applicable motor model represents design order.
• Suffix of “*” in the applicable motor model represents the motor structure.

10. Check of the Combination of the Driver and the Motor

Absolute Specifications, 17-bit

This driver is designed to be used in a combination with the motor which are specified by us. Check the series name of the motor, rated output torque, voltage specifications and encoder specifications.

Caution ❗ Do not use in other combinations than those listed below.

Motor					Driver	
Power supply	Type	Rated rotational speed	Model	Rated output	Model	Frame
Single phase, 100V	MSME Low inertia	3000r/min	MSME5AZS1*	50W	MADHT1105	A-frame
			MSME011S1*	100W	MADHT1107	
			MSME021S1*	200W	MBDHT2110	
			MSME041S1*	400W	MCDHT3120	
Single/ 3-phase, 200V			MSME5AZS1*	50W	MADHT1505	A-frame
			MSME012S1*	100W		
			MSME022S1*	200W	MADHT1507	
			MSME042S1*	400W	MBDHT2510	
			MSME082S1*	750W	MCDHT3520	
			MSME102S□*	1.0kW	MDDHT5540	D-frame
			MSME152S□*	1.5kW		
			3-phase, 200V	MSME202S□*	2.0kW	MEDHT7364
MSME302S□*	3.0kW	MFDHTA390		F-frame		
MSME402S□*	4.0kW	MFDHTB3A2				
MSME502S□*	5.0kW					
Single/3-phase, 200V	MDME Middle inertia	2000r/min	MDME102S□*	1.0kW	MDDHT3530	D-frame
3-phase, 200V			MDME152S□*	1.5kW	MDDHT5540	
			MDME202S□*	2.0kW	MEDHT7364	
			MDME302S□*	3.0kW	MFDHTA390	
			MDME402S□*	4.0kW	MFDHTB3A2	
MDME502S□*			5.0kW			
Single/3-phase, 200V	MFME Middle inertia	2000r/min	MFME152S1*	1.5kW	MDDHT5540	D-frame
3-phase, 200V			MFME252S1*	2.5kW	MEDHT7364	E-frame
			MFME452S1*	4.5kW	MFDHTB3A2	F-frame
Single/3-phase, 200V	MGME Middle inertia	1000r/min	MGME092S□*	900W	MDDHT5540	D-frame
3-phase, 200V			MGME202S□*	2.0kW	MFDHTA390	F-frame
			MGME302S□*	3.0kW	MFDHTB3A2	
			MGME452S1*	4.5kW		
Single/3-phase, 200V	MHME High inertia	2000r/min	MHME102S□*	1.0kW	MDDHT3530	D-frame
3-phase, 200V			MHME152S□*	1.5kW	MDDHT5540	
			MHME202S□*	2.0kW	MEDHT7364	
			MHME302S□*	3.0kW	MFDHTA390	
			MHME402S□*	4.0kW	MFDHTB3A2	
MHME502S□*			5.0kW			

- Note** ❗
- Suffix of "□" in the applicable motor model represents design order.
Suffix of "*" in the applicable motor model represents the motor structure.
 - Default of the driver is set for the incremental encoder specifications.
When you use in absolute, make the following operations.
 - Install a battery for absolute encoder.
 - Switch the parameter Pr0.15 (Absolute encoder setup) from "1 (default)" to "0".

11. Specifications

Basic Specifications

Input power	100V	Main circuit	Single phase, 100 to 120V	+ 10% - 15%	50/60Hz	
		Control circuit	Single phase, 100 to 120V	+ 10% - 15%	50/60Hz	
	200V	Main circuit	A to D-frame	Single/3-phase, 200 to 240V	+ 10% - 15%	50/60Hz
			E to F-frame	3-phase, 200 to 230V	+ 10% - 15%	50/60Hz
		Control circuit	A to D-frame	Single phase, 200 to 240V	+ 10% - 15%	50/60Hz
		E to F-frame	Single phase, 200 to 230V	+ 10% - 15%	50/60Hz	
Control method			IGBT PWM Sinusoidal wave drive			
Encoder feedback			17-bit (131072 resolution) absolute encoder, 7-wire serial 20-bit (1048576 resolution) incremental encoder, 5-wire serial			
External scale feedback			A/B phase, initialization signal differential input. Manufacturers that support serial communication scale: Mitsutoyo Corp. Magrescale Co., Ltd.			
Parallel I/O connector	Control signal	Input	General purpose 10 inputs The function of general-purpose input is selected by parameters.			
		Output	General purpose 6 outputs The function of general-purpose input is selected by parameters.			
	Analog signal	Input	3 inputs (16Bit A/D : 1 input, 12Bit A/D : 2 inputs)			
		Output	2 outputs (Analog monitor: 2 output)			
	Pulse signal	Input	2 inputs (Photo-coupler input, Line receiver input)			
		Output	4 outputs (Line driver: 3 output, open collector: 1 output)			
Communication function		USB	Connection with PC etc.			
		RS232	1 : 1 communication			
		RS485	1 : n communication up to 31 axes to a host.			
Safety function			Used for IEC61800-5-2: STO.			
Front panel			(1) 5 keys (MODE, SET, UP, DOWN, SHIFT) (2) LED (6-digit) (3) Monitor connector (Analog monitor output (2ch), Digital monitor output (1ch))			
Regeneration			A, B-frame: no built-in regenerative resistor (external resistor only) C to F-frame: Built-in regenerative resistor (external resistor is also enabled.)			
Dynamic brake			Built-in			
Control mode			Switching among the following 7 mode is enabled, (1) Position control (2) Velocity control (3) Torque control (4) Position/Velocity control (5) Position/Torque control (6) Velocity/Torque control (7) Full-closed control			

11. Specifications

Functions

Position control	Control input		(1) Deviation counter clear (2) Command pulse inhibition (3) Command dividing gradual increase switching (4) Damping control switching etc.
	Control output		Positioning complete (In-position) etc.
	Pulse input	Max. command pulse frequency	Exclusive interface for Photo-coupler: 500kpps Exclusive interface for line driver : 4Mpps
		Input pulse signal format	Differential input
		Electronic gear (Division/Multiplication of command pulse)	1/1000 to 1000 times
		Smoothing filter	Primary delay filter or FIR type filter is adaptable to the command input
	Analog input	Torque limit command input	Individual torque limit for both positive and negative direction is enabled.
		Torque feed forward input	Analog voltage can be used as torque feed forward input.
	Instantaneous Speed Observer		Available
	Damping Control		Available
Velocity control	Control input		(1) Selection of internal velocity setup 1 (2) Selection of internal velocity setup 2 (3) Selection of internal velocity setup 3 (4) Speed zero clamp etc.
	Control output		Speed arrival etc.
	Analog input	Velocity command input	Speed command input can be provided by means of analog voltage. Parameters are used for scale setting and command polarity.
		Torque limit command input	Individual torque limit for both positive and negative direction is enabled.
		Torque feed forward input	Analog voltage can be used as torque feed forward input.
	Internal velocity command		Switching the internal 8speed is enabled by command input.
	Soft-start/down function		Individual setup of acceleration and deceleration is enabled, with 0 to 10s/1000r/min. Sigmoid acceleration/deceleration is also enabled.
	Zero-speed clamp		Speed zero clamp input is enabled.
	Instantaneous Speed Observer		Available
	Velocity Control filter		Available

11. Specifications

Functions

Torque control	Control input		Speed zero clamp, Torque command sign input etc.	
	Control output		Speed arrival etc.	
	Analog input	Torque command input	Torque command input can be provided by means of analog voltage. Parameters are used for scale setting and command polarity.	
Speed limit function		Speed limit value with parameter is enabled.		
Full-closed control	Control input		(1) Deviation counter clear (2) Command pulse inhibition (3) Command dividing gradual increase switching (4) Damping control switching etc.	
	Control output		Full-closed positioning complete etc.	
	Pulse input	Max. command pulse frequency	Exclusive interface for Photo-coupler: 500kpps Exclusive interface for line driver : 4Mpps	
		Input pulse signal format	Differential input	
		Electronic gear (Division/Multiplication of command pulse)	1/1000 to 1000 times	
		Smoothing filter	Primary delay filter or FIR type filter is adaptable to the command input	
	Analog input	Torque limit command input	Individual torque limit for both positive and negative direction is enabled.	
		Torque feed forward input	Analog voltage can be used as torque feed forward input.	
	Setup range of division/multiplication of feedback scale		1/40 to 160 times	
	Auto tuning		The load inertia is identified in real time by the driving state of the motor operating according to the command given by the controlling device and set up support software "PANATERM". The gain is set automatically in accordance with the rigidity setting.	
Division of encoder feedback pulse		Set up of any value is enabled (encoder pulses count is the max.).		
Protective function	Hard error	Over-voltage, under-voltage, over-speed, over-load, over-heat, over-current and encoder error etc.		
	Soft error	Excess position deviation, command pulse division error, EEPROM error etc.		
Traceability of alarm data		The alarm data history can be referred to.		
Common	Auto tuning		The load inertia is identified in real time by the driving state of the motor operating according to the command given by the controlling device and set up support software "PANATERM". The gain is set automatically in accordance with the rigidity setting.	
	Division of encoder feedback pulse		Set up of any value is enabled (encoder pulses count is the max.).	

After-Sale Service (Repair)

Repair

Consult to a dealer from whom you have purchased the product for details of repair. When the product is incorporated to the machine or equipment you have purchased, consult to the manufacturer or the dealer of the machine or equipment.

Cautions for Proper Use

- Practical considerations for exporting the product or assembly containing the product
When the end user of the product or end use of the product is associated with military affair or weapon, its export may be controlled by the Foreign Exchange and Foreign Trade Control Law. Complete review of the product to be exported and export formalities should be practiced.
- This product is intended to be used with a general industrial product, but not designed or manufactured to be used in a machine or system that may cause personal death when it is failed.
- Installation, wiring, operation, maintenance, etc., of the equipment should be done by qualified and experienced personnel.
- Apply adequate tightening torque to the product mounting screw by taking into consideration strength of the screw and the characteristics of material to which the product is installed. Overtightening can damage the screw and/or material; undertightening can result in loosening.
Example) Steel screw (M5) into steel section: 2.7-3.3 N·m.
- Install a safety equipments or apparatus in your application, when a serious accident or loss of property is expected due to the failure of this product.
- Consult us if the application of this product is under such special conditions and environments as nuclear energy control, aerospace, transportation, medical equipment, various safety equipments or equipments which require a lesser air contamination.
- We have been making the best effort to ensure the highest quality of the products, however, application of exceptionally larger external noise disturbance and static electricity, or failure in input power, wiring and components may result in unexpected action. It is highly recommended that you make a fail-safe design and secure the safety in the operative range.
- If the motor shaft is not electrically grounded, it may cause an electrolytic corrosion to the bearing, depending on the condition of the machine and its mounting environment, and may result in the bearing noise. Checking and verification by customer is required.
- Failure of this product depending on its content, may generate smoke of about one cigarette. Take this into consideration when the application of the machine is clean room related.
- Please be careful when using in an environment with high concentrations of sulfur or sulfuric gases, as sulfuration can lead to disconnection from the chip resistor or a poor contact connection.

- Take care to avoid inputting a supply voltage which significantly exceeds the rated range to the power supply of this product. Failure to heed this caution may result in damage to the internal parts, causing smoking and/or a fire and other trouble.
- The user is responsible for matching between machine and components in terms of configuration, dimensions, life expectancy, characteristics, when installing the machine or changing specification of the machine. The user is also responsible for complying with applicable laws and regulations.
- The product will not be guaranteed when it is used outside its specification limits.
- Parts are subject to minor change to improve performance.

Technical information

Technical information of this product (Operating Instructions, CAD data) can be downloaded from the following web site.

http://industrial.panasonic.com/ww/i_e/25000/motor_fa_e/motor_fa_e.html

For your records:

The model number and serial number of this product can be found on either the back or the bottom of the unit. Please note them in the space provided and keep for future reference.

Model No.	M <input type="checkbox"/> DH _____	Serial No.	
	M <input type="checkbox"/> ME _____		
Date of purchase			
Dealer	Name		
	Address		
	Phone	()	-

Motor Business Unit, Panasonic Corporation

7-1-1 Morofuku, Daito, Osaka, 574-0044, Japan Phone : +81-72-871-1212

© Panasonic Corporation 2009

Motor Business Unit, Panasonic Corporation

7-1-1 Morofuku, Daito, Osaka, 574-0044, Japan Phone : +81-72-871-1212

© Panasonic Corporation 2009

Printed in China

IMD88+A
Z0409-1111