

LTC7821

12V, 20A Hybrid Step-Down Synchronous Converter

DESCRIPTION

Demonstration circuit 2513B is a high efficiency, high power density hybrid converter. It can deliver 12V/20A with an input voltage from 36V to 72V. This demo board features the [LTC®7821](#), which uses an architecture that merges soft-switching switched-capacitor topology with a traditional step-down converter to provide superior efficiency compared to the traditional switching architectures. It offers a high efficiency/high density and cost effective solution for nonisolated intermediate bus applications in power distribution, datacom and telecom as well as emerging 48V automotive systems.

External MOSFETs switch at a 500kHz fixed frequency for this demo board and can be programmed from 200kHz to 1.5MHz. The LTC7821's powerful 1Ω N-channel MOSFET gate drivers maximize efficiency and can drive multiple MOSFETs in parallel for higher power applications. Due to its current mode control architecture, multiple LTC7821s can be operated in a parallel, multiphase configuration with excellent current sharing and low output voltage ripple to enable much higher power applications. Other benefits include low EMI emissions due to a soft-switched front end and reduced MOSFET stress.

The LTC7821 design eliminates the inrush current typically associated with switched capacitor circuits by pre-balancing the capacitors on start-up. The LTC7821 also monitors system voltage, current and temperature for faults, and uses a sense resistor for overcurrent protection. It stops switching and pulls the $\overline{\text{FAULT}}$ pin low when a fault condition occurs. An onboard timer can be set for appropriate restart/retry times.

Additional features include $\pm 1\%$ output voltage accuracy over temperature, a clock output for multiphase operation, a power good output signal, short-circuit protection, monotonic output voltage start-up, optional external reference, undervoltage lockout and internal charge balance circuitry.

The LTC7821 data sheet must be used in conjunction with this demo board manual.

[Design files for this circuit board are available.](#)

All registered trademarks and trademarks are the property of their respective owners.

PERFORMANCE SUMMARY Specifications are at $T_A = 25^\circ\text{C}$

PARAMETER	CONDITION	VALUE
Input Voltage Range		36V to 72V
Output Voltage, V_{OUT}	$V_{IN} = 36\text{V to }72\text{V}, I_{OUT} = 0\text{A to }20\text{A}$	12V
Maximum Output Current, I_{OUT}	$V_{IN} = 36\text{V to }72\text{V}, V_{OUT} = 12\text{V}$	20A
Typical Efficiency	$V_{IN} = 48\text{V}, V_{OUT} = 12\text{V}, I_{OUT} = 20\text{A}$	97.3%
Peak Efficiency	$V_{IN} = 48\text{V}, V_{OUT} = 12\text{V}$	97.5%
Switching Frequency		500kHz

QUICK START PROCEDURE

Demonstration circuit 2513B is easy to set up to evaluate the performance of the LTC7821. Refer to Figure 1 for the proper measurement equipment setup and follow the procedure below.

1. With power off, connect the input power supply to V_{IN} (36V to 72V) and GND (input return).
2. Connect the output loads between V_{OUT} and GND (Initial load: no load). Refer to Figure 1.
3. Connect the DVMs to the input and output.
4. Check the default jumper/switch position: SW1 (RUN): OFF; JP2 (BIAS): ON.
5. Turn on the input power supply and adjust voltage to 48V;
NOTE. Make sure that the input voltage does not exceed 72V.
6. Turn on the switches: SW1: ON.
7. Check for the proper output voltages from VO_SNS^+ to VO_SNS^- .
8. Once the proper output voltage is established, adjust the loads within the operating range and measure the efficiency, output ripple voltage and other parameters.
9. After completing all tests, adjust the load to 0A, power off the input power supply.

Notes:

1. When measuring the output or input voltage ripple, do not use the long ground lead on the oscilloscope probe. See Figure 2 for the proper scope probe technique. Short, stiff leads need to be soldered to the (+) and (-) terminals of an output capacitor. The probe's ground ring needs to touch the (-) lead and the probe tip needs to touch the (+) lead.
2. When doing the load step test with the onboard dynamic load circuit, please make sure the load step-up pulse duty cycle does not exceed 2% and the pulse duration is less than 500 μ s so that the temperature of the MOSFETs Q9, Q10 in the dynamic load circuit stay in the safe region. Instead of using the onboard dynamic load circuit, an electric load can also be used for the load step test, which does not have the 2% max duty cycle limit for the load step.

QUICK START PROCEDURE

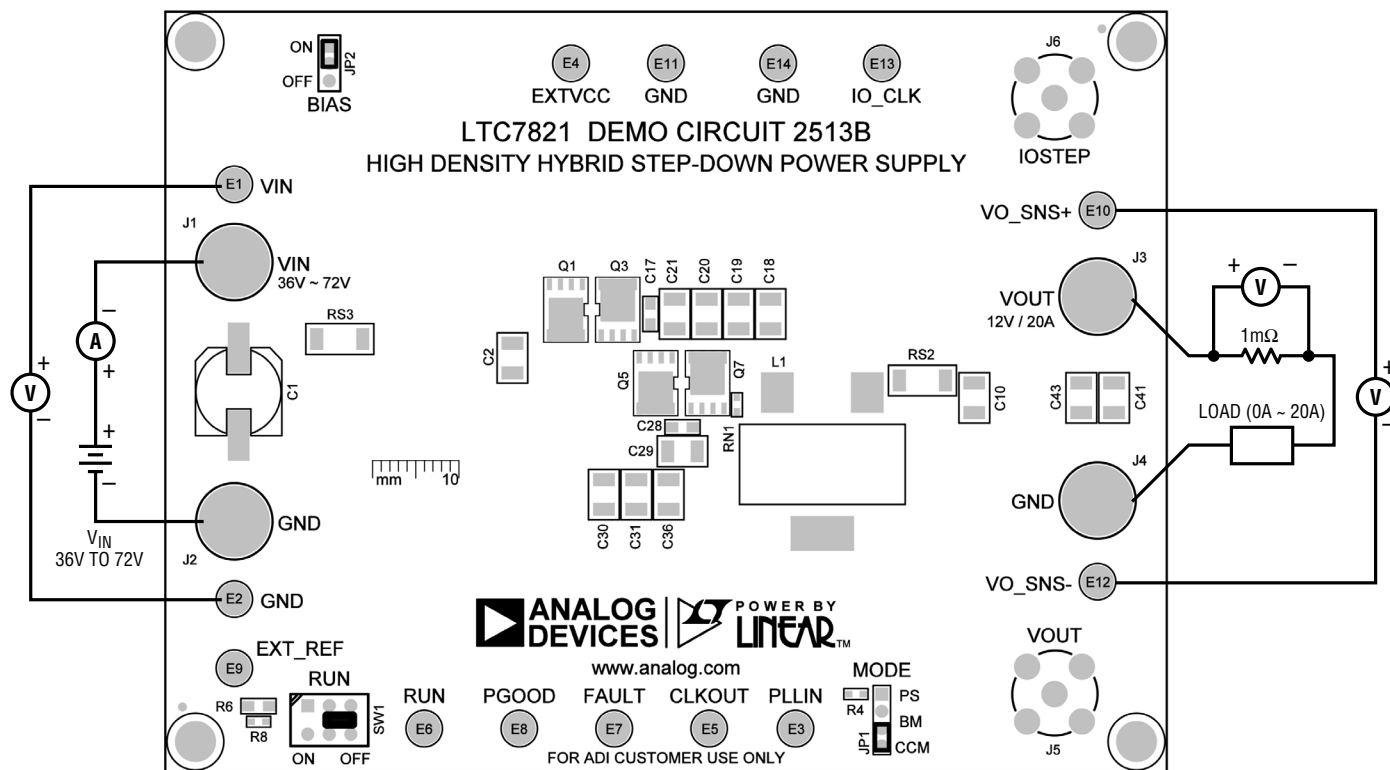

Figure 1. Proper Measurement Equipment Setup

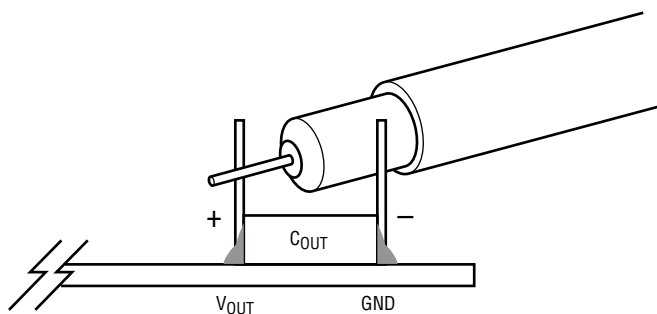
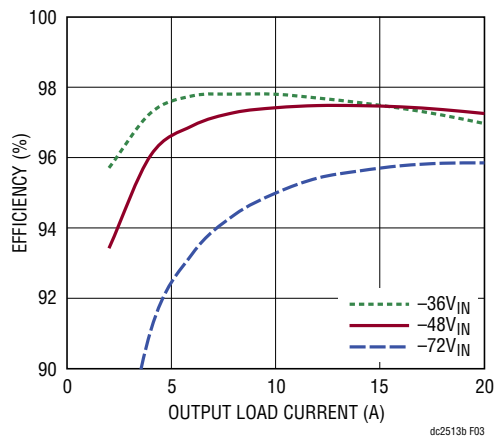

Figure 2. Measuring Output Voltage Ripple

QUICK START PROCEDURE



**Figure 3. Efficiency vs Load Current at $V_{IN} = 36V \sim 72V$, $V_{OUT} = 12V$, $f_{SW} = 500kHz$
Note: Tested with External 8V Bias**

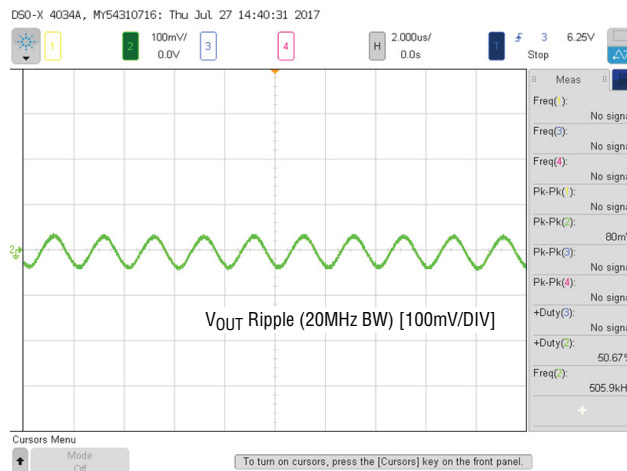
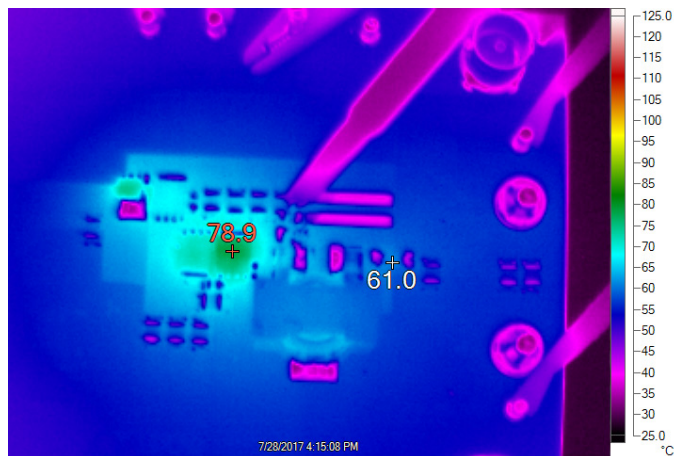

Figure 4. Output Voltage Ripple at $V_{IN} = 48V$, $V_{OUT} = 12V$, $I_{OUT} = 20A$, $f_{SW} = 500kHz$



Figure 5. Load Step at $V_{IN} = 48V$, $V_{OUT} = 12V$



**Figure 6. Thermal Performance $V_{IN} = 48V$, $V_{OUT} = 12V$, $I_{OUT} = 20A$, $T_A = 23^\circ C$, No Airflow
Note: Tested with External 8V Bias**

PARTS LIST

ITEM	QTY	REFERENCE	PART DESCRIPTION	MANUFACTURER/PART NUMBER
Required Circuit Components				
1	1	C1	CAP, 33 μ F, 20%, 80V POLYMER HYBRID ALUM ELEC	PANASONIC EEHZA1K330P
2	8	C2, C3, C47, C49, C56, C57, C58, C59	CAP, 1210, 2.2 μ F, 10%, 100V, X7R	MURATA GRM32DR72A225KA12K
3	4	C4, C5, C15, C37	CAP, 0603, 0.1 μ F, 10%, 100V, X7R	MURATA GRM188R72A104KA35D
4	1	C6	CAP, 0805, 4.7 μ F 10%, 16V, X7R	MURATA GRM21BR71C475KA73K
5	1	C7	CAP, 0805, 4.7 μ F, 10%, 25V, X7R	MURATA GRM21BR71E475KA73L
6	2	C8, C40	CAP, 0603, 0.22 μ F, 10%, 25V, X7R	MURATA GRM188R71E224KA88D
7	1	C9	CAP, 0603, 0.47 μ F, 10%, 25V, X7R	MURATA GRM188R71E474KA12D
8	19	C10, C18, C19, C20, C21, C22, C23, C24, C25, C29, C30, C31, C32, C33, C34, C35, C36, C41, C43	CAP, 1210, 10 μ F, 10%, 50V, X7R	MURATA GRM32ER71H106KA12L
9	2	C17, C28	CAP, 0805, 2.2 μ F, 10%, 50V X7R	TDK C2012X7R1H225K125AC
10	3	C26, C27, C50	CAP, 0603, 1 μ F, 20%, 25V, X5R	AVX 06033D105MAT2A
11	1	C39	CAP, 6800pF, X7R, 50V, 10%, 0603	AVX 06035C682KAT2A
12	2	C42, C44	CAP, 150 μ F, 20%, 16V	PANASONIC 16SVPC150M
13	1	C45	CAP, 56pF, C0G, 50V, 5%, 0603	MURATA GRM1885C1H560JA01D
14	2	C52, C53	CAP, 1210, 22 μ F, 10%, 25V, X5R	AVX 12103D226KAT2A
15	1	C54	CAP, 0603, 47nF, 10%, 25V, X7R	AVX 06033C473KAT2A
16	1	C55	CAP, 0603, 220pF, 10%, 50V, X7R	AVX 06035C221KAT2A
17	3	D1, D2, D3	DIODE, SCHOTTKY	CENTRAL SEMI. CMDSH-4E.TR LEAD-FREE
18	1	L1	IND, 2 μ H 20%	COILCRAFT SER2011-202MLD
19	1	L2	IND, 68 μ H	COILCRAFT LPS6225-683MRB
20	1	Q1	XSTR, N-CHANNEL MOSFET	INFINEON BSZ070N08LS5ATMA1
21	2	Q3, Q5	XSTR, N-CHANNEL MOSFET	INFINEON BSC032N04LS
22	1	Q7	XSTR, N-CHANNEL MOSFET	INFINEON BSC014N04LSI
23	2	Q9, Q10	XSTR, MOSFET N-CHANNEL, 40V TO 252V	VISHAY SILICONIX SUD50N04-8M8P-4GE3
24	4	RS1, RS2, RS3, RS4	RES., 2010, 0 Ω JUMPER	VISHAY WSL201000000ZEA9
25	2	R1, R7	RES, 0603, 1k, 1%, 0.1W	VISHAY CRCW06031K00FKEA
26	1	R2	RES, 0603, 2.2 Ω , 5%, 0.1W	VISHAY CRCW06032R20JNEA
27	1	R4	RES, 0603, 20k, 1%, 0.1W	VISHAY CRCW060320K0FKEA
28	7	R5, R10, R12, R19, R20, R24, R32	RES, 0603, 0 Ω , JUMPER	VISHAY CRCW06030000Z0EA
29	1	R6	RES, 0805, 1M Ω , 1%, 0.125W	VISHAY CRCW08051M00FKEA
30	1	R8	RES, 0603, 39.2k, 1%, 1/10W	VISHAY CRCW060339K2FKEA
31	3	R9, R13, R28	RES, 0603, 10k, 1%, 0.1W	VISHAY CRCW060310K0FKEA
32	1	R15	RES, 0603, 100k, 1%, 0.1W	VISHAY CRCW0603100KFKEA
33	1	R16	RES, 0603, 68k, 1%, 0.1W	VISHAY CRCW060368K0FKEA
34	1	R17	RES, 0805, 6.81k, 1%, 0.1W	VISHAY CRCW08056K81FKEA
35	1	R18	RES, 0603, 29.4k, 1%, 1/10W	VISHAY CRCW060329K4FKEA
36	1	R23	RES, 0805, 60.4k 1%, 0.125W	VISHAY CRCW080560K4FKEA
37	1	R25	RES, 0603, 4.32k, 1%, 0.1W	VISHAY CRCW06034K32FKEA
38	1	R26	RES, 0603, 182k, 1%, 0.1W	VISHAY CRCW0603182KFKEA

DEMO MANUAL DC2513B

PARTS LIST

ITEM	QTY	REFERENCE	PART DESCRIPTION	MANUFACTURER/PART NUMBER
39	1	R27	RES, 0603 20k 5% 0.1W	VISHAY CRCW060320K0JNEA
40	1	R29	RES, 0603 80.6k 1% 0.1W	VISHAY CRCW060380K6FKEA
41	1	R30	RES. 2010 0.1Ω 1% 1W	VISHAY WSL2010R1000FEA18
42	1	U1	IC, LTC7821EUH	ANALOG DEVICES LTC7821EUH
43	1	U2	IC, SYNCHRONOUS STEP-DOWN CONVERTER	ANALOG DEVICES LTC3630EMSE

Additional Demo Board Circuit Components

1	0	C16, C38, C46, C48, C51	CAP, 0603 OPTION	OPTION
2	0	Q2, Q4, Q6, Q8	XSTR, N-CHANNEL MOSFET OPTION	OPTION
3	0	RN1	THERMISTOR, OPTION	OPTION
4	0	R3, R11, R14, R21, R22	RES, 0603 OPTION	OPTION

Hardware

1	14	E1, E2, E3, E4, E5, E6, E7, E8, E9, E10, E11, E12, E13, E14	TURRET	MILL-MAX 2501-2-00-80-00-00-07-0
2	1	JP1	HEADER, 4-PIN, 2mm	WURTH ELEKTRONIK 6200041121
3	1	JP2	HEADER, 3-PIN 2mm	WURTH ELEKTRONIK 6200031121
4	4	J1, J2, J3, J4	JACK, BANANA	KEYSTONE 575-4
5	2	J5, J6	CON, BNC, 5-PIN	CONNEX 112404
6	1	SW1	SWITCH, SUBMINATURE SLIDE	C&K JS202011CQN
7	2	XJP1, XJP2	SHUNT 2mm	WURTH ELEKTRONIK 60800213421
8	4	X2, X3, X5, X6	STANDOFF, SNAP ON	KEYSTONE 8834

SCHEMATIC DIAGRAM

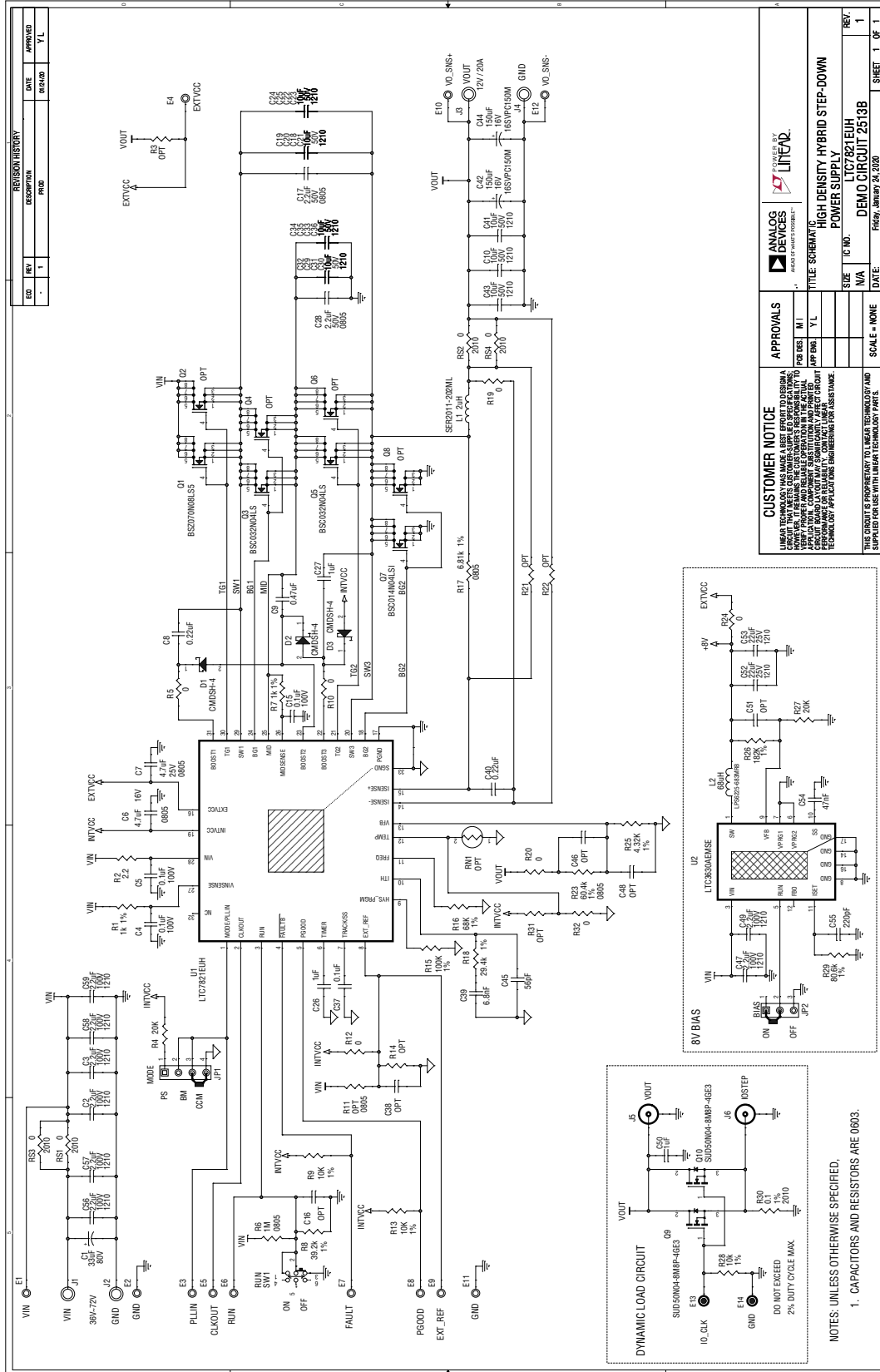



ESD Caution

ESD (electrostatic discharge) sensitive device. Charged devices and circuit boards can discharge without detection. Although this product features patented or proprietary protection circuitry, damage may occur on devices subjected to high energy ESD. Therefore, proper ESD precautions should be taken to avoid performance degradation or loss of functionality.

Legal Terms and Conditions

By using the evaluation board discussed herein (together with any tools, components documentation or support materials, the "Evaluation Board"), you are agreeing to be bound by the terms and conditions set forth below ("Agreement") unless you have purchased the Evaluation Board, in which case the Analog Devices Standard Terms and Conditions of Sale shall govern. Do not use the Evaluation Board until you have read and agreed to the Agreement. Your use of the Evaluation Board shall signify your acceptance of the Agreement. This Agreement is made by and between you ("Customer") and Analog Devices, Inc. ("ADI"), with its principal place of business at One Technology Way, Norwood, MA 02062, USA. Subject to the terms and conditions of the Agreement, ADI hereby grants to Customer a free, limited, personal, temporary, non-exclusive, non-sublicensable, non-transferable license to use the Evaluation Board FOR EVALUATION PURPOSES ONLY. Customer understands and agrees that the Evaluation Board is provided for the sole and exclusive purpose referenced above, and agrees not to use the Evaluation Board for any other purpose. Furthermore, the license granted is expressly made subject to the following additional limitations: Customer shall not (i) rent, lease, display, sell, transfer, assign, sublicense, or distribute the Evaluation Board; and (ii) permit any Third Party to access the Evaluation Board. As used herein, the term "Third Party" includes any entity other than ADI, Customer, their employees, affiliates and in-house consultants. The Evaluation Board is NOT sold to Customer; all rights not expressly granted herein, including ownership of the Evaluation Board, are reserved by ADI. CONFIDENTIALITY. This Agreement and the Evaluation Board shall all be considered the confidential and proprietary information of ADI. Customer may not disclose or transfer any portion of the Evaluation Board to any other party for any reason. Upon discontinuation of use of the Evaluation Board or termination of this Agreement, Customer agrees to promptly return the Evaluation Board to ADI. ADDITIONAL RESTRICTIONS. Customer may not disassemble, decompile or reverse engineer chips on the Evaluation Board. Customer shall inform ADI of any occurred damages or any modifications or alterations it makes to the Evaluation Board, including but not limited to soldering or any other activity that affects the material content of the Evaluation Board. Modifications to the Evaluation Board must comply with applicable law, including but not limited to the RoHS Directive. TERMINATION. ADI may terminate this Agreement at any time upon giving written notice to Customer. Customer agrees to return to ADI the Evaluation Board at that time. LIMITATION OF LIABILITY. THE EVALUATION BOARD PROVIDED HEREUNDER IS PROVIDED "AS IS" AND ADI MAKES NO WARRANTIES OR REPRESENTATIONS OF ANY KIND WITH RESPECT TO IT. ADI SPECIFICALLY DISCLAIMS ANY REPRESENTATIONS, ENDORSEMENTS, GUARANTEES, OR WARRANTIES, EXPRESS OR IMPLIED, RELATED TO THE EVALUATION BOARD INCLUDING, BUT NOT LIMITED TO, THE IMPLIED WARRANTY OF MERCHANTABILITY, TITLE, FITNESS FOR A PARTICULAR PURPOSE OR NON-INFRINGEMENT OF INTELLECTUAL PROPERTY RIGHTS. IN NO EVENT WILL ADI AND ITS LICENSORS BE LIABLE FOR ANY INCIDENTAL, SPECIAL, INDIRECT, OR CONSEQUENTIAL DAMAGES RESULTING FROM CUSTOMER'S POSSESSION OR USE OF THE EVALUATION BOARD, INCLUDING BUT NOT LIMITED TO LOST PROFITS, DELAY COSTS, LABOR COSTS OR LOSS OF GOODWILL. ADI'S TOTAL LIABILITY FROM ANY AND ALL CAUSES SHALL BE LIMITED TO THE AMOUNT OF ONE HUNDRED US DOLLARS (\$100.00). EXPORT. Customer agrees that it will not directly or indirectly export the Evaluation Board to another country, and that it will comply with all applicable United States federal laws and regulations relating to exports. GOVERNING LAW. This Agreement shall be governed by and construed in accordance with the substantive laws of the Commonwealth of Massachusetts (excluding conflict of law rules). Any legal action regarding this Agreement will be heard in the state or federal courts having jurisdiction in Suffolk County, Massachusetts, and Customer hereby submits to the personal jurisdiction and venue of such courts. The United Nations Convention on Contracts for the International Sale of Goods shall not apply to this Agreement and is expressly disclaimed.