



Specification Catalog

5 Series **500R11**

Indoor Split Geothermal Heat Pump
2-6 ton (single speed)
2-6 ton (dual capacity)

Table of Contents

The 5 Series	4
Model Nomenclature	5
AHRI Data	6-7
5 Series Indoor Split Features	8
5 Series Design Features	9-10
The Aurora™ Control System	11-19
Water Quality	20
Dimensional Data	21
Physical Data	22
Electrical Data	22
Model Nomenclature - Air Handler	23
Air Handler Compatibility	23
Physical Data - Air Handler	24
Line Set Sizes	25
Model Nomenclature - Coil	26
Refrigerant Coil Compatibility	26
SR Coil Data	26
Reference Calculations	27
Legend and Notes	27
Operating Limits	28
Antifreeze Corrections	28
Correction Factor Tables	29
Pressure Drop	30
Performance Data	31-47
Wiring Schematics	48-51
Engineering Guide Specifications	52-53
Revision Guide	54

5 Series

500R11 Geothermal Heat Pump



5 Series indoor splits are designed for indoor installations, and are connected to an indoor air handler via refrigerant lines and control wiring. NSZ and NDZ units utilize the ozone-safe R-410A refrigerant to meet the most stringent EPA requirements now and for many years to come. Easily accessible controls and connections for refrigerant piping and water piping make this unit simple to install in a wide variety of applications. Heavy gauge metal cabinets are coated with durable poly paint for long lasting beauty and protection. No matter what the installation, the 5 Series

indoor split will provide exceptional performance and comfort for many years. And because there is no outdoor blower like ordinary air conditioners or heat pumps, the NSZ and NDZ is exceptionally quiet. A new sophisticated Aurora™ Control system is modular and designed to grow with the application. The Aurora 'Base' Control (ABC) features a microprocessor control to sequence all components during operation for optimum performance. Plus, the ABC provides easy-to-use troubleshooting features with fault lights, on-board diagnostics, and a hand held Aurora Interface Diagnostic (AID) Tool. The Aurora 'Advanced' Control adds the Aurora Expansion Board (AXB) to further extend the capability of the system to include compressor current monitoring, advanced loop and hot water generator pump control, as well as service, performance, and energy monitoring sensor kit capability. Aurora Weblink (AWL) allows remote access to the thermostat via WiFi to the internet or smartphone as well as remote monitoring of the heat pump and receives lockout/fault info via text or e-mail.

5 Series products are performance-certified to AHRI/ISO 13256-1 standards, ETL listed, ENERGY STAR® qualified, and tested in an ISO 17025 accredited testing lab.

As a leader in the industry, WaterFurnace is dedicated to innovation, quality, and customer satisfaction. In fact, every unit built is exposed to a wide range of quality control procedures throughout the assembly process and is then subjected to a rigorous battery of computerized run tests to certify that it meets or exceeds performance standards for efficiency and safety, and will perform flawlessly at startup. As further affirmation of our quality standards, each unit carries our exclusive Quality Assurance emblem, signed by the final test technician.

WaterFurnace International's corporate headquarters ISO 9001:2008 and manufacturing facility is located in Fort Wayne, IN. A scenic three-acre pond located in front of the building serves as our geothermal heating and cooling source to comfort-condition our 110,000 square feet of manufacturing and office space. As a pioneer, and now a leader in the industry, the team of WaterFurnace engineers, customer support staff, and skilled assembly technicians is dedicated to providing the finest comfort systems available.



All 5 Series products are safety listed under UL1995 thru ETL and performance listed with AHRI in accordance with standard 13256-1. The 5 Series is also ENERGY STAR rated.

Model Nomenclature

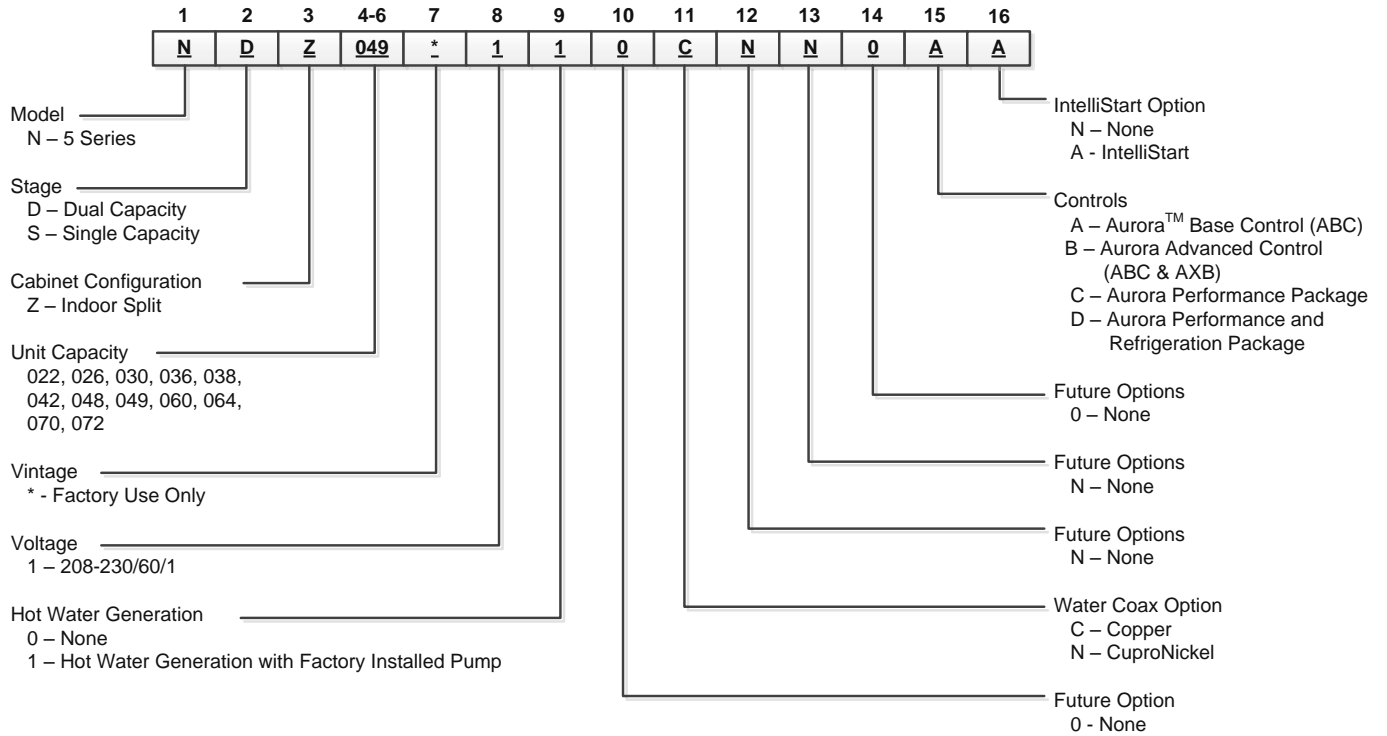

Rev.: 17, October 2016

AHRI Data

Model	SAH Air Handler Model	Capacity Modulation	Flow Rate		Water Loop Heat Pump				Ground Water Heat Pump				Ground Loop Heat Pump			
					Cooling Brine EWT 86°F		Heating Brine EWT 68°F		Cooling EWT 59°F		Heating EWT 50°F		Cooling Brine Full Load 77°F Part Load 68°F		Heating Brine Full Load 32°F Part Load 41°F	
			gpm	cfm	Capacity Btuh	EER Btuh/W	Capacity Btuh	COP	Capacity Btuh	EER Btuh/W	Capacity Btuh	COP	Capacity Btuh	EER Btuh/W	Capacity Btuh	COP
026	026	Full	8	850	22,500	15.0	28,100	5.0	25,800	23.0	23,300	4.6	23,400	17.5	18,400	3.7
		Part	7	750	17,400	17.0	21,200	6.0	20,000	29.0	17,400	5.0	19,200	24.5	15,500	4.3
038	036	Full	9	1200	34,400	16.3	41,600	5.2	38,200	24.2	35,100	4.7	36,000	19.0	27,900	4.0
		Part	8	800	24,600	18.3	30,000	5.4	28,000	32.5	25,100	4.7	27,000	27.0	22,500	4.2
049	048	Full	12	1500	43,200	15.4	56,300	5.1	51,000	24.2	47,100	4.6	46,300	18.0	37,700	3.9
		Part	11	1300	32,500	17.0	41,600	5.9	39,400	31.0	34,000	4.9	37,500	25.8	30,000	4.4
064	060	Full	16	1800	54,800	15.0	66,900	4.8	63,200	22.5	56,000	4.4	57,400	17.0	45,200	3.7
		Part	14	1500	40,900	16.5	48,900	5.4	48,500	29.0	40,100	4.6	46,300	24.5	35,600	4.1
072	066	Full	18	2000	60,400	14.0	81,000	4.5	70,000	22.0	67,500	4.1	62,800	16.0	53,500	3.5
		Part	16	1600	46,600	15.3	61,400	5.2	54,600	26.5	50,800	4.2	51,900	22.0	45,300	3.9
022	022	Single	8	800	17,800	16.2	22,100	5.7	20,400	26.5	18,100	4.8	18,700	19.1	14,000	3.8
030	030	Single	8	1000	23,400	15.9	30,600	5.7	26,900	25.6	24,900	4.8	24,600	18.9	19,800	3.9
036	036	Single	9	1200	29,100	17.4	35,600	5.8	33,200	27.4	29,600	4.9	30,600	20.4	23,100	4.0
042	042	Single	11	1300	36,000	16.7	43,100	5.5	41,300	25.6	36,000	4.8	37,800	19.5	27,400	3.9
048	048	Single	12	1500	39,300	15.3	50,000	5.3	46,900	25.5	41,900	4.7	42,500	18.7	33,400	4.0
060	060	Single	15	1800	53,500	14.9	64,500	4.8	61,700	23.6	54,500	4.3	56,300	17.7	44,000	3.7
070	066	Single	18	2000	57,100	13.8	74,700	4.6	66,400	21.7	62,100	4.1	60,500	16.2	50,700	3.6

Cooling capacities based upon 80.6°F DB, 66.2°F WB entering air temperature

Heating capacities based upon 68°F DB, 59°F WB entering air temperature

All ratings based upon operation at the lower voltage of dual voltage rated models.

11/21/2016

Energy Star Compliance Table

Model	Tier 3	
	Ground Water	Ground Loop
026	Yes	Yes
038	Yes	Yes
049	Yes	Yes
064	Yes	Yes
072	Yes	Yes
022	Yes	Yes
030	Yes	Yes
036	Yes	Yes
042	Yes	Yes
048	Yes	Yes
060	Yes	Yes
070	Yes	Yes

NOTE: This product meets Energy Star requirements when purchased with a minimum 5 year warranty and appropriate coil components are used. Ask your contractor for details.

1/16/17

Energy Star Rating Criteria

In order for water-source heat pumps to be Energy Star rated they must meet or exceed the minimum efficiency requirements listed below.

Tier 3: 1/1/2012 - No Effective End Date Published

	EER	COP
Closed loop water-to-air	17.1	3.6
Open loop water-to-air	21.1	4.1
Closed loop water-to-water	16.1	3.1
Open loop water-to-water	20.1	3.5



AHRI Data cont.

The performance standard AHRI/ASHRAE/ISO 13256-1 became effective January 1, 2000 and replaces ARI Standards 320, 325, and 330. This new standard has three major categories: Water Loop (comparable to ARI 320), Ground Water (ARI 325), and Ground Loop (ARI 330). Although these standards are similar there are some differences:

Unit of Measure: The Cooling COP

The cooling efficiency is measured in EER (US version measured in Btu/h per Watt. The Metric version is measured in a cooling COP (Watt per Watt) similar to the traditional COP measurement.

Water Conditions Differences

Entering water temperatures have changed to reflect the centigrade temperature scale. For instance the water loop heating test is performed with 68°F (20°C) water rounded down from the old 70°F (21.1°C).

Air Conditions Differences

Entering air temperatures have also changed (rounded down) to reflect the centigrade temperature scale. For instance the cooling tests are performed with 80.6°F (27°C) dry bulb and 66.2°F (19°C) wet bulb entering air instead of the traditional 80°F (26.7°C) DB and 67°F (19.4°C) WB entering air temperatures. 80.6/66.2 data may be converted to 80/67 using the entering air correction table. This represents a significantly lower relative humidity than the old 80/67 of 50% and will result in lower latent capacities.

Pump Power Correction Calculation

Within each model, only one water flow rate is specified for all three groups and pumping Watts are calculated using the following formula. This additional power is added onto the existing power consumption.

- Pump power correction = (gpm x 0.0631) x (Press Drop x 2990) / 300

Where 'gpm' is waterflow in gpm and 'Press Drop' is the pressure drop through the unit heat exchanger at rated water flow in feet of head.

Blower Power Correction Calculation

Blower power is corrected to zero external static pressure using the following equation. The nominal airflow is rated at a specific external static pressure. This effectively reduces the power consumption of the unit and increases cooling capacity but decreases heating capacity. These Watts are significant enough in most cases to increase EER and COPs fairly dramatically over ARI 320, 325, and 330 ratings.

- Blower Power Correction = (cfm x 0.472) x (esp x 249) / 300

Where 'cfm' is airflow in cfm and 'esp' is the external static pressure at rated airflow in inches of water gauge.

ISO Capacity and Efficiency Calculations

The following equations illustrate cooling calculations:

- ISO Cooling Capacity = Cooling Capacity (Btu/h) + (Blower Power Correction (Watts) x 3.412)
- ISO EER Efficiency (W/W) = ISO Cooling Capacity (Btu/h) x 3.412 / [Power Input (Watts) - Blower Power Correction (Watts) + Pump Power Correction (Watt)]

The following equations illustrate heating calculations:

- ISO Heating Capacity = Heating Capacity (Btu/h) - (Blower Power Correction (Watts) x 3.412)
- ISO COP Efficiency (W/W) = ISO Heating Capacity (Btu/h) x 3.412 / [Power Input (Watts) - Blower Power Correction (Watts) + Pump Power Correction (Watt)]

Comparison of Test Conditions

	ARI 320	ISO/AHRI 13256-1 WLHP	ARI 325	ISO/AHRI 13256-1 GWHP	ARI 330	ISO/AHRI 13256-1 GLHP
Cooling						
Entering Air - DB/WB °F	80/67	80.6/66.2	80/67	80.6/66.2	80/67	80.6/66.2
Entering Water - °F	85	86	50/70	59	77	77
Fluid Flow Rate	*	**	**	**	**	**
Heating						
Entering Air - DB/WB °F	70	68	70	68	70	68
Entering Water - °F	70	68	50/70	50	32	32
Fluid Flow Rate	*	**	**	**	**	**

Note *: Flow rate is set by 10°F rise in standard cooling test Part load entering water conditions not shown.

Note **: Flow rate is specified by the manufacturer

WLHP = Water Loop Heat Pump; GWHP = Ground Water Heat Pump; GLHP = Ground Loop Heat Pump

Conversions:

Airflow (lps) = cfm x 0.472;

ESP (Pascals) = ESP (in wg) x 249;

WaterFlow (lps) = GPM x 0.0631;

Press Drop (Pascals) = Press Drop (ft hd) x 2990

5 Series Indoor Split Features



- ① **COMPRESSOR:** Copeland Scroll™ (022-070 single speed) and Copeland Scroll UltraTech™ (dual capacity 026-072) represent the latest technology
- ② **DOUBLE ISOLATED COMPRESSOR:** Double isolated compressor mounting to reduce noise and vibration
- ③ **AURORA CONTROLS & AID TOOL:** Aurora 'Base' Control, Aurora 'Advanced' Control, and Aurora AID Tool
- ④ **COAXIAL HEAT EXCHANGER:** Standard large high efficiency copper (optional cupronickel) coax with our exclusive void-free and robotically applied ThermaShield insulation coating
- ⑤ **BALANCED PORT EXPANSION VALVE:** Balanced port expansion valve for steady superheat control and reliable efficiency and operation at any condition (not shown)
- ⑥ **DISCHARGE MUFFLER:** Helps quiet compressor gas pulsations
- ⑦ **SWIVEL LOOP CONNECTIONS:** Leak free swivel water connections provide a hand tight gasket connection that easily handles the temperature extremes of geothermal earth loops
- ⑧ **INTELLISTART®:** Optional single phase soft starter
- ⑨ **INSULATION:** Cleanable foil lined insulation to prevent mold growth (not shown)
- ⑩ **CABINET FINISH:** Heavy gauge galvanized sheet metal cabinet has 1,000 hr. salt spray rated gray powder coat paint for long life
- ⑪ **ACCESS PANELS:** Lift out front bottom access panel, lift out panels for easier removal and servicing
- ⑫ **AID TOOL PORT:** AID Tool port provides quick AID Tool connection
- ⑬ **ACCUMULATOR:** Safeguards the compressor against liquid refrigerant flowback
- ⑭ **SERVICE VALVES:** Brass service valves with service port for easy installation, charging, and service
- ⑮ **RECESSED LINE SET:** Line set stubs are recessed to protect service valves during shipment
- ⑯ **DECORATIVE COVER:** Matching painted cover for line set stubs after brazing enhances cabinet appearance
- ⑰ **LIQUID LINE FILTER DRIER:** Removes moisture and contaminants from the refrigerant stream ensuring trouble-free operation (not shown)

5 Series Design Features

What's New?

- Latest technology compressors
 - Copeland K5 Scrolls™ in single speed units (sizes 022, 030, 036, 042, 048, 060, 070)
 - Copeland UltraTech™ K5 Compressors in dual capacity units (sizes 026, 038, 049, 064, 072)
- Communicating Digital Thermostats: The Aurora controls system features either monochromatic or color touch screen graphic display thermostats for user interface with the 5 Series system. These displays not only feature easy to use graphical interface but display alerts and faults in plain English.
- Aurora™ Communicating Control Features
 - *Traditional Safety Sensors:* HP, LP, freeze detection loop, freeze detection air coil
 - *Communicating Modular Design:* Communicating modular design for flexibility and expandability
 - *Intelligent Hot Water Generator Control:* The Aurora Advanced control determines operation of hot water assist dependent upon system parameters to maximize overall system efficiency.
 - *Loop pump linking:* For multiple units on one flow center with either variable speed, single, or dual capacity units (with Aurora Advanced Control); even works with our legacy controls
 - *Internet Ready:* With optional Aurora WebLink (AWL) device and Symphony Web Portal
- Advanced Service Features
 - Aurora Controls with the AID Tool provide advanced service diagnostics. With this device setup and configurations as well as real-time sensors fault and lockout history can be monitored and much more.
 - Aurora can be internet capable simply by adding the Aurora WebLink (AWL). This device will connect your Aurora system to web for remote monitoring and control. It also comes standard with an SD drive for storing operating and performance data. Providing 'black box' capability.
 - Condensate overflow detection when Air Handler is equipped with control option 'C' AHB.

- Monitoring Sensor Kits
 - *Energy Monitoring:* With this standard sensor kit, the Aurora Advanced Control will feature power monitoring of the compressor; the information can be displayed on AID Tool, selected thermostats, or through AWL
 - *Refrigerant Monitoring:* The 5 Series features refrigeration service sensors as an optional feature; now superheat, subcooling, refrigerant pressures, and various temperatures needed to diagnose unit problems are readily available at your finger tips in the AID Tool
 - *Performance Monitoring:* With this optional sensor kit installation, the Aurora controls can measure actual capacity and efficiency performance of the heat pump; the information can be displayed on AID Tool or thru AWL
- Cupronickel heat exchanger

Application Flexibility

- Safe, efficient operation in a wide range of liquid temperatures (20°F to 120°F) and flow rates (as low as 1.5 gpm/ton in open loop applications when EWT >50°F)
- Corner-located electrical box for field wiring from two sides
- Circuit breaker protected loop pump power block for easy wiring
- Relay to control field-mounted accessories
- Field-selectable freeze detection setting for well or closed loop systems
- Loop pump linking feature allows multiple units to share one flow center (requires Aurora 'Advanced' Control option)

Operating Efficiencies

- AHRI 13256-1 rating for heating COPs, cooling EERs and low water flow requirements
- High-stability expansion valve delivers optimum refrigerant flow over a wide range of conditions
- Efficient Copeland scroll compressors provide superior comfort levels
- Optional hot water generator with internal pump generates hot water at considerable savings while improving overall system efficiency.
- Accumulator is on all models for added compressor reliability
- Oversized coaxial tube water-to-refrigerant heat exchanger operates at low liquid pressure drops
- Convoluted cupronickel water tube functions efficiently at low flow rates, and provides freeze-damage resistance
- Utilizes the ozone-friendly R-410A refrigerant which produces higher efficiencies and warmer discharge air temperatures

5 Series Design Features cont.

Service Advantages

- Hinged/removable control box for added serviceability
- Removable panels: three for the compressor compartment provide quick access to all internal components
- Easily accessible thermal expansion valve
- Brass, swivel-type water connections for quick connection union, and elimination of wrenches and sealants during installation; sweat type connections are on the hot water generator
- Designed for front access in tight applications
- LED fault and status lights on the Aurora board with memory for easy diagnostics
- Aurora AID Tool provides enhanced service information via communication directly with the Aurora control including sensor inputs, fault history, and much more
- Detachable thermostat connection strip for wiring convenience
- Hot water pump shut-off switch for easy startup and service
- Control box has quick-attach wiring plugs for easy removal
- High- and low-pressure service ports in refrigerant circuit

Microprocessor Benefits

- Communicating monochromatic or color digital auto-changeover thermostat with 3-stage heating/2-stage cooling holds precise temperature and provides varying blower speed control
- Hot water limit prevents scalding, and pump shuts down automatically when full unit capacity is needed for heating
- Communication capability for future expansions

Options and Accessories

- Communicating Digital Thermostats
 - *Monochromatic Graphic Display Thermostats:* For user interface with the Aurora system; these displays not only feature easy to use graphical interface but display alerts and faults in plain English. When Energy Monitoring is added, instantaneous usage is displayed on the thermostat itself.
 - *Color Touch Screen Graphic Display Thermostats:* For user interface with the Aurora system; these displays not only feature easy to use graphical interface but display alerts and faults in plain English. When Energy Monitoring is added not only instantaneous usage is displayed but also weekly and annual consumptions are stored and graphed. Other features include full color implementation, user loaded background photos, and USB port for easy configuration and software updates.

- AID Tool: The Aurora Interface and Diagnostics (AID) Tool is a plug-in configuration and troubleshooting tool for the Aurora Control System
- Aurora WebLink (AWL) : The Aurora Control System can be made internet capable simply by adding the Aurora WebLink (AWL) device. The AWL will connect your Aurora system to the web for remote monitoring and control. It also comes standard with an SD disc for storing operating and performance data providing true 'black box' capability for troubleshooting
- Optional Aurora 'Advanced' Controls (see controls description)
- Optional cupronickel heat exchangers for open loop applications
- Optional hot water generator with internally mounted pump and water heater plumbing connector
- IntelliZone2 Zone System: The IntelliZone2 zoning system provides up to 4 zones (Dual Capacity), or 2 zones (Single Speed) of individualized comfort via communication to the Aurora Control System. Requires AXB board in a compressor section or AHB board in Air handler.
- IntelliZone2 • 24V is a non-communicating zoning system that uses a daughter board to translate communication to 24 VAC for the heat pump (no AXB and AHB). Maximum of 4 zones (Dual Capacity) or 2 zones (Single Speed).
- Closed loop flow center and loop circulating kits.
- Additional accessory relay
- Bramec III, 6x6 modular mounting pad
- IntelliStart compressor soft starter
- SRA encased and uncased coil assemblies

Manufacturing Quality

- All units are computer run-tested, with conditioned source water, in all modes to ensure efficiency and reliability
- All refrigerant brazing is performed in a nitrogen atmosphere
- All units are deep evacuated to less than 150 microns prior to refrigerant charging
- All joints are helium leak-tested to ensure an annual leak rate of less than 1/4 ounce
- All major components bar coded; eliminating possibility of mismatched parts built into unit
- All assembly technicians thoroughly trained in proper quality procedures
- All units have model number and serial number embedded in control for local or remote retrieval
- WaterFurnace International, Inc. is an ISO 9001:2008 certified manufacturing facility
- WaterFurnace International, Inc. engineering labs are ISO 17025 accredited

The Aurora™ Control System

Aurora 'Base' Control

The Aurora 'Base' Control (ABC) System is a complete residential and commercial comfort system that brings all aspects of the HVAC system into one cohesive module network. The ABC features microprocessor control and HP, LP, condensate (with AHB in air handler) and freeze detection, over/under voltage faults, along with communicating thermostat capability for complete fault detection text at the thermostat.

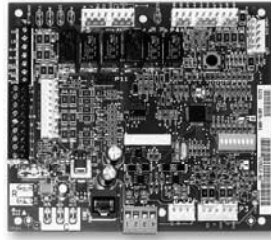

Aurora uses the Modbus communication protocol to communicate between modules. Each module contains the logic to control all features that are connected to the module. The Aurora 'Base' Control (ABC) has two Modbus channels. The first channel is configured as a master for connecting to devices such as a communicating thermostat, expansion board, or other slave devices. The second channel is configured as a slave for connecting the Aurora Interface Diagnostics Tool (AID Tool).

NOTE: The software on the ABC and AXB control boards is unique to the operation of the Geo-Split. Refer to the AURORA Toolbox for the current software versions.

Aurora 'Advanced' Control

The Aurora 'Advanced' Control expands on the capability of the Aurora 'Base' Control (ABC) System by adding the Aurora Expansion Board (AXB). The additional features include compressor current monitoring, loop pump linking, intelligent hot water generator control, variable speed pump capability, and also allows for optional energy, refrigeration, and performance monitoring factory installed add-on sensor kits. The AXB also features a second field configurable accessory relay, and two home automation inputs that are AID configurable for different types of alarms from sump pumps to home security. The Smart Grid input is AID configurable with many options to react to Utility controlled relay operation for ON Peak optimization. For IntelliZone2 compatibility the SAH Air Handler must have control option C (AHB Board) or the compressor section must have an AXB board. IntelliZone2 may be connected to P7 on either the AXB or AHB boards.

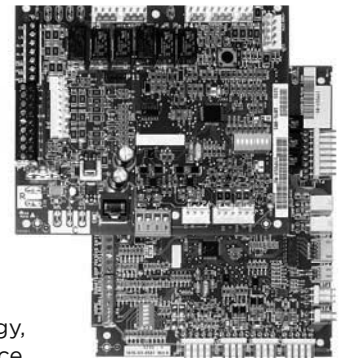





Aurora Control Features	Description	Aurora 'Base'	Aurora 'Advanced'
Microprocessor Compressor Control	Microprocessor control of compressor for timings with FP1, HP, LP, Condensate, assignable Acc relay	•	•
Advanced Microprocessor Features	Smart Grid, Home Automation Alarm Inputs, and Accessory2 Relay (HRV/ERV)	-	•
Base Hot Water Generator Operation	Compressor Contactor powers Hot Water Generator Pump with inline circuit breaker and thermostat limit.	•	See below
Advanced Hot Water Generator Control	Microprocessor and separate power relay for Hot Water Generator Pump with digital temperature monitoring and multiple HWG setpoint selection.	-	•
Base Loop Pump Control	Compressor Contactor powers Loop Pump with inline circuit breaker and no loop pump linking capability.	•	See below
Advanced Speed Pump Control	Microprocessor and separate power relay for loop pump and inline circuit breakers and loop pump linking.	-	•
Variable Speed Pump	Capable of setup, monitoring and controlling a variable speed flow center.	-	•
Compressor Monitoring	Control monitors compressor starts for high current, missing leg etc.	-	•
Smart Grid/Utility Input	Allows simple input to externally enable of occupied/unoccupied mode for basic utility time of use programs.	-	Dry Contact x1
Home Automation Alarm Input	Allows simple input to signal sump, security, or smoke/CO sensor alarms from other home automation or security systems. The two inputs can be field configured to a number of options and logic.	-	Dry Contactx2
HAN/Smart Grid Com (AWL and Portal) Kit	Allows direct communication of the Aurora to Smart Meters, Home Automation Network and Internet.	-	Optional AWL
IntelliZone2® Compatibility	IntelliZone2 communicates Modbus to the heat pump via the AXB or AHB boards.	With Optional AXB Kit and IntelliZone2	Optional IntelliZone2
IntelliZone2 • 24V Compatibility	Communicates to the heat pump via 24VAC (AXB and AHB not required)	•	-

The Aurora Control System cont.

Service Device	Description	Aurora 'Base'	Aurora 'Advanced'
 <p>Aurora Interface and Diagnostics (AID) Tool</p>	<p>Allows setup, monitoring and troubleshooting of any Aurora Control.</p> <p>NOTE: Although the ABC has basic compatibility with all Aurora, new product features may not be available on older AID Tools. To simplify the basic compatibility ensure the version of AID is at least the same or greater than the ABC software version.</p>	For Service (Ver. 1.xx or greater)	For Service (Ver. 2.xx or greater)

Add On Control Feature Kits (field or factory installed)	Description	Aurora 'Base'	Aurora 'Advanced'
Geo Energy Monitoring Kit	Monitors realtime power consumption of compressor, blower, aux heat and pump. Requires thermostat TPCM32UO3A, TPCM32UO4A, or TPCC32UO1. AXB required. AHB required in air handler for blower and auxiliary heat power consumption monitoring.	-	Standard
Refrigeration Monitoring Kit	Monitors realtime pressures, temperatures, superheat, and subcooling. AXB required. AHB required in air handler for LAT (leaving air temperature).	-	Optional Sensor Kit
Performance Monitoring Kit	Monitors air and water temperatures, and water flow rate and calculates heat of extraction/rejection. AXB required.	-	Optional Sensor Kit
Data Logging (AWL) Kit	Allows data logging of up to 12 months. AXB required. Can also be temporarily installed.	-	Optional
HAN/Smart Grid Com (AWL and Portal) Kit	Allows direct communication of the Aurora to Smart Meters, HAN, and internet. AXB required.	-	Optional
AXB Kit for advanced hot water generator control, flow center linking, variable speed pump, IntelliZone2	Added for key features of advanced hot water generator control, advanced loop control/linking, IntelliZone2 communication, and variable speed pump control.	Optional (Field Kit)	Standard

Add On Thermostats and Zoning	Description	Aurora 'Base'	Aurora Advanced
 <p>TP32U03/04 - MonoChrome Traditional Y1, Y2 Thermostat</p>	Elite Stat with full English fault codes and alerts, traditional Y1, Y2 thermostat. Not compatible with AWL.	Optional	Optional
 <p>TP32S01/02 - Traditional Y1, Y2 Thermostat</p>	Traditional Y1, Y2 thermostat. Not compatible with AWL.	Optional	Optional
 <p>TPCM32U03A/04A - MonoChrome Communicating Thermostat</p>	Elite Stat with full English fault codes and alerts, communicating thermostat. Monochrome thermostat allows instantaneous energy measurement only. Compatible with AWL.	Optional	Optional
 <p>TPCC32U01 - Color Touchscreen Communicating Thermostat</p>	4.3 in. color touchscreen communicating thermostat with full English fault codes and alerts. Color thermostat allows instantaneous energy measurement and 13 month energy usage history. Compatible with AWL.	Optional	Optional
IntelliZone2 • 24V Zoning Compatibility	IntelliZone2 • 24V is a non-communicating zoning system requiring Y1, Y2 signals that controls up to 4 zones (dual capacity) and 2 zones (single speed.) For systems without the optional AXB and AHB boards.	Optional (5-Speed ECM)	Optional (IntelliZone2 Preferred)
 <p>IntelliZone2® Zoning</p>	IntelliZone2® is a communicating zoning system that includes color main thermostat and up to 6 zones (with variable speed, 4 zones (with dual capacity), and 2 zones (with single speed). There are 4 thermostat options (MasterStat, TPCC32U01, SensorStat, ZoneStat). Compatible with AWL. System must have either AXB or AHB board.	-	Optional (IntelliZone2 Preferred)

The Aurora 'Base' Control System cont.

Aurora 'Base' Control



NOTE: Refer to the Aurora Base Control Application and Troubleshooting Guide and the Instruction Guide: Aurora Interface and Diagnostics (AID) Tool for additional information.

Control Features

Software ABC Geo-Split Version 3.0

Single or Dual Capacity Compressors

Either single or dual capacity compressors can be operated.

Other Control Features

- Random start at power up
- Anti-short cycle protection
- High and low pressure cutouts
- Loss of charge
- Water coil freeze detection
- Over/under voltage protection
- Load shed
- Dehumidification (where applicable)
- Emergency shutdown
- Hot gas reheat operation (where applicable)
- Diagnostic LED
- Test mode push button switch
- Two auxiliary electric heat outputs
- Alarm output
- Accessory output with N.O. and N.C.
- Modbus communication (primary)
- Modbus communication (secondary)

Field Selectable Options via Hardware

DIP Switch (SW1) – Test/Configuration Button (See SW1 Operation Table)

Test Mode

The control is placed in the test mode by holding the push button switch SW1 for 2 - 5 seconds. In test mode most of the control timings will be shortened by a factor of sixteen (16). LED3 (green) will flash at 1 second on and 1 second off. Additionally, when entering test mode LED1 (red) will flash the last lockout one time. Test mode will automatically time out after 30 minutes. Test mode can be exited by pressing and holding the SW1 button for 2 to 5 seconds or by cycling the power. **NOTE:** Test mode will automatically be exited after 30 minutes.

Reset Configuration Mode

The control is placed in reset configuration mode by holding the push button switch SW1 for 50 to 60 seconds. This will reset all configuration settings and the EEPROM back to the factory default settings. LED3 (green) will turn off when entering reset configuration mode. Once LED3 (green) turns off, release SW1 and the control will reset.

DIP Switch (SW2)

SW2-1 FP1 Selection – Low water coil temperature limit setting for freeze detection. On = 30°F; Off = 15°F.

SW2-2 FP2 Selection – On = 30°F; Off = N/A

SW2-3 RV – O/B - thermostat type. Heat pump thermostats with “O” output in cooling or “B” output in Heating can be selected. On = O; Off = B.

SW2-4 Access Relay Operation (P2)

and 2-5

Access Relay Operation	SW2-4	SW2-5
Cycle with Blower	ON	ON
Cycle with Compressor	OFF	OFF
Water Valve Slow Opening	ON	OFF
Cycle with Comm. T-stat Hum Cmd	OFF	ON

The Aurora 'Base' Control System cont.

Cycle with Blower - The accessory relay will cycle with the blower output.

Cycle with Compressor - The accessory relay will cycle with the compressor output.

Water Valve Slow Opening - The accessory relay will cycle and delay both the blower and compressor output for 90 seconds.

SW2-6 CC Operation - selection of single or dual capacity compressor. On = Single Stage; Off = Dual Capacity

SW2-7 Lockout and Alarm Outputs (P2) - selection of a continuous or pulsed output for both the LO and ALM Outputs. On = Continuous; Off = Pulsed

SW2-8 Future Use

Alarm Jumper Clip Selection

From the factory, ALM is connected to 24 VAC via JW2. By cutting JW2, ALM becomes a dry contact connected to ALG.

Safety Features

The following safety features are provided to protect the compressor, heat exchangers, wiring and other components from damage caused by operation outside of design conditions.

Fuse - a 3 amp automotive type plug-in fuse provides protection against short circuit or overload conditions.

Anti-Short Cycle Protection - 4 minute anti-short cycle protection for the compressor.

Random Start - 5 to 80 second random start upon power up.

Fault Retry - in the fault condition, the control will stage off the outputs and then "try again" to satisfy the thermostat Y input call. Once the thermostat input calls are satisfied, the control will continue on as if no fault occurred. If 3 consecutive faults occur without satisfying the thermostat Y input call, then the control will go to Lockout mode.

Lockout - when locked out, the blower will operate continuously in "G" speed, and PSC blower motor output will remain on. The Alarm output (ALM) and Lockout output (L) will be turned on. The fault type identification display LED1 (Red) shall flash the fault code. To reset lockout conditions with SW2-8 On, thermostat inputs "Y1", "Y2", and "W" must be removed for at least 3 seconds. To reset lockout conditions with SW2-8 Off, thermostat inputs "Y1", "Y2", "W", and "DH" must be removed for at least 3 seconds. Lockout may also be reset by turning power off for at least 30 seconds or by enabling the emergency shutdown input for at least 3 seconds.

Lockout With Emergency Heat - if the control is locked out in the heating mode, and a Y2 or W input is received, the control will operate in the emergency heat mode while the compressor is locked out. The first emergency heat output will be energized 10 seconds after the W input is received, and the blower will shift to high speed. If the control remains locked out, and the W input is present, additional stage of emergency heat will stage on after 2 minutes. When the W input is removed, all of the emergency heat outputs will turn off, and the ECM blower will shift to "G" speed and PSC blower motor output will remain on.

High Pressure - fault is recognized when the Normally Closed High Pressure Switch, P4-9/10 opens, no matter how momentarily. The High Pressure Switch is electrically in series with the Compressor Contactor and serves as a hard-wired limit switch if an overpressure condition should occur.

Low Pressure - fault is recognized when the Normally Closed Low Pressure Switch, P4-7/8 is continuously open for 30 seconds. Closure of the LPS any time during the 30 second recognition time restarts the 30 second continuous open requirement. A continuously open LPS shall not be recognized during the 2 minute startup bypass time.

Loss of Charge - fault is recognized when the Normally Closed Low Pressure Switch, P4-7/8 is open prior to the compressor starting.

Freeze Detection (Coax) - set points shall be either 30°F or 15°F. When the thermistor temperature drops below the selected set point, the control shall begin counting down the 30 seconds delay. If the thermistor value rises above the selected set point, then the count should reset. The resistance value must remain below the selected set point for the entire length of the appropriate delay to be recognized as a fault. This fault will be ignored for the initial 2 minutes of the compressor run time.

The Aurora 'Base' Control System cont.

Over/Under Voltage Shutdown - An over/under voltage condition exists when the control voltage is outside the range of 18 VAC to 30 VAC. If the over/under voltage shutdown lasts for 15 minutes, the lockout and alarm relay will be energized. Over/under voltage shutdown is self-resetting in that if the voltage comes back within range of 18 VAC to 30 VAC for at least 0.5 seconds, then normal operation is restored.

Operation Description

Power Up - The unit will not operate until all the inputs and safety controls are checked for normal conditions. The unit has a 5 to 80 second random start delay at power up. Then the compressor has a 4 minute anti-short cycle delay after the random start delay.

Standby In standby mode, Y1, Y2, W, DH, and G are not active. Input O may be active. The blower and compressor will be off.

Heating Operation

Heating, 1st Stage (Y1) - (Single/Dual Capacity Compressor and Variable Speed ECM) The blower is started on "G" speed immediately and the compressor is energized 10 seconds after the Y1 input is received. The ECM blower motor is switched to low speed 15 seconds after the Y1 input.

Heating, 1st Stage (Y1) - (Single/Dual Capacity Compressor and 5 Speed ECM) The blower is started on "Y1" speed immediately and the compressor is energized 10 seconds after the Y1 input is received.

Heating, 2nd Stage (Y1, Y2) (Single/Dual Capacity Compressor and Variable Speed ECM) - The compressor will be staged to full capacity 20 seconds after Y2 input is received. The ECM blower will shift to high speed 15 seconds after the Y2 input is received.

Heating, 2nd Stage (Y1, Y2) (Single/Dual Capacity Compressor and 5 Speed ECM) - The compressor will be staged to full capacity 20 seconds after Y2 input is received. The 5 speed ECM blower will shift to Y2 speed immediately.

Heating, 3rd Stage (Y1, Y2, W) (Single/Dual Capacity Compressor and Variable Speed ECM) - The hot water pump is de-energized and the first stage of electric heat is energized 10 seconds after the W command is received. If the demand continues the second stage of electric heat will be energized after 5 minutes.

Heating, 3rd Stage (Y1, Y2, W) (Single/Dual Capacity Compressor and 5 Speed ECM) - The first stage of electric heat is energized 10 seconds after the W command is received. Blower will increase to "W" speed immediately. If the demand continues the second stage of electric heat will be energized after 5 minutes.

Emergency Heat (W) - The blower will be started on "G" speed, 10 seconds later the first stage of electric heat will be turned on. 5 seconds after the first stage of electric heat is energized the blower will shift to Aux speed. If the emergency heat demand is not satisfied after 2 minutes the second electric heat stage will be energized.

Cooling Operation

In all cooling operations, the reversing valve directly tracks the O input. Thus, anytime the O input is present, the reversing valve will be energized.

Cooling, 1st Stage (Y1, O) (Single/Dual Capacity Compressor and Variable Speed ECM) - The blower is started on "G" speed immediately and the compressor is energized 10 seconds after the Y1 input is received. The ECM blower motor is switched to low speed 15 seconds after the Y1 input.

Cooling, 1st Stage (Y1, O) (Single/Dual Capacity Compressor and 5 Speed ECM) - The blower is started on "Y1" speed immediately and the compressor is energized 10 seconds after the Y1 input is received.

Cooling, 2nd Stage (Y1, Y2, O) (Single/Dual Capacity Compressor and Variable Speed ECM) - The compressor will be staged to full capacity 20 seconds after Y2 input is received. The ECM blower will shift to high speed 15 seconds after the Y2 input is received.

Cooling, 2nd Stage (Y1, Y2, O) (Single/Dual Capacity Compressor and 5 Speed ECM) - The compressor will be staged to full capacity 20 seconds after Y2 input is received. The 5 speed ECM blower will shift to Y2 speed immediately.

Emergency Shutdown - Four (4) seconds after a valid ES input, P2-7 is present, all control outputs will be turned off and remain off until the emergency shutdown input is no longer present. The first time that the compressor is started after the control exits the emergency shutdown mode, there will be an anti-short cycle delay followed by a random start delay. Input must be tied to common to activate.

Load Shed - The LS input disables all outputs with the exception of the blower output. When the LS input has been cleared, the anti-short cycle timer and random start timer will be initiated. Input must be tied to common to activate.

The Aurora 'Base' Control System cont.

Aurora 'Base' Control LED Displays

These three LEDs display the status, configuration, and fault codes for the control. These can also be read in plain English via the Aurora AID Tool.

Status LED (LED3, Green)

Description of Operation	Fault LED, Green
Normal Mode	ON
Control is Non-functional	OFF
Test Mode	Slow Flash
Lockout Active	Fast Flash
Dehumidification Mode	Flash Code 2
(Future Use)	Flash Code 3
(Future Use)	Flash Code 4
Load Shed	Flash Code 5
ESD	Flash Code 6
(Future Use)	Flash Code 7

Configuration LED (LED2, Yellow)

Description of Operation	Configuration LED, Yellow
No Software Overwritten	Flashing ECM Setting
DIP Switch was Overwritten	Slow Flash
ECM Configuration Mode	Fast Flash

Fault LED (LED1, Red)

Red Fault LED		LED Flash Code*	Lockout	Reset/Remove
ABC Basic Faults	Normal - No Faults	OFF	-	
	Fault - Input	1	No	Auto
	Fault - High Pressure	2	Yes	Hard or Soft
	Fault - Low Pressure	3	Yes	Hard or Soft
	Fault - Freeze Detection FP2	4	Yes	Hard or Soft
	Fault - Freeze Detection FP1	5	Yes	Hard or Soft
	Fault - Condensate Overflow	7	Yes	Hard or Soft
	Fault - Over/Under Voltage	8	No	Auto
	Fault - FP1 Sensor Error	11	Yes	Hard or Soft
Fault - CritComErr	19	NO	Auto	

NOTE: All codes >11 use long flash for tens digit and short flash for the ones digit. 20, 30, 40, 50, etc. are skipped.

Aurora Interface and Diagnostics (AID) Tool

The Aurora Interface and Diagnostics (AID) Tool is a device that is a member of the Aurora network. The AID Tool is used to troubleshoot equipment which uses the Aurora control via Modbus RTU communication. The AID Tool provides diagnostics, fault management, variable speed ECM setup, and system configuration capabilities to the Aurora family of controls. An AID Tool is recommended, although not required, for ECM airflow settings. The AID Tool simply plugs into the exterior of the cabinet in the AID Tool port.



ABC Control Board Layout

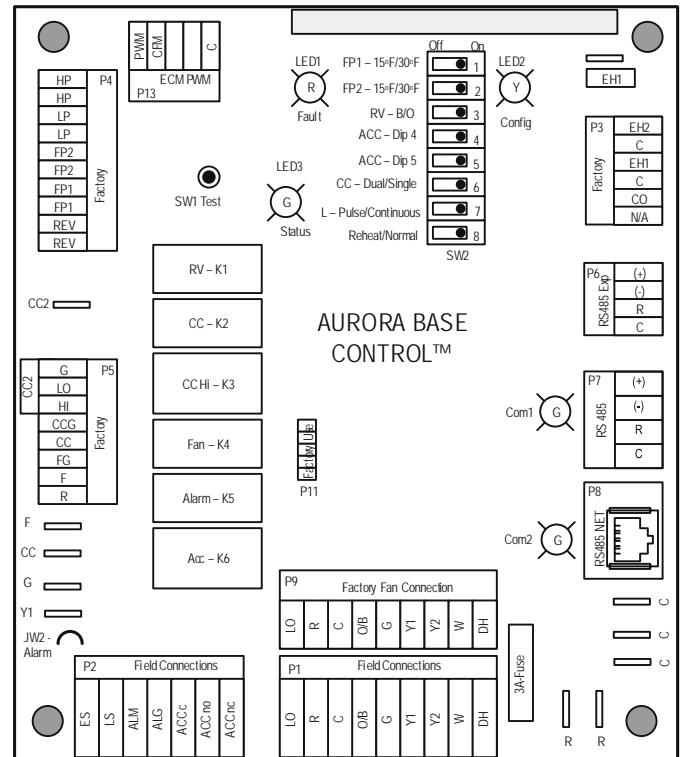

The Aurora 'Advanced' Control System

Aurora 'Advanced' Control Features

The Aurora 'Advanced' Control system expands on the capability of the Aurora 'Base' Control (ABC) by adding the Aurora Expansion Board (AXB). All of the preceding features of the Aurora 'Base' Control are included. The following control description is of the additional features and capability of the Aurora advanced control.

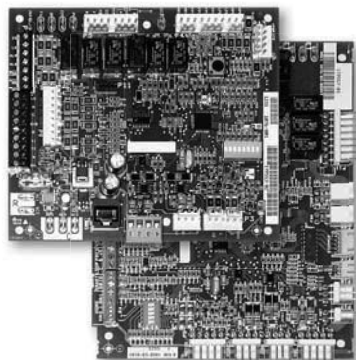

It is highly recommended the installing/servicing contractor obtain an Aurora Interface and Diagnostic Tool (AID) and specialized training before attempting to install or service an Aurora 'Advanced' control system.



The additional AXB features include the following:

AXB DIP Switch

DIP 1 - ID: This is the AXB ModBus ID and should always read On.

DIP 2 & 3 - Future Use

DIP 4 & 5 - Accessory Relay2: A second, DIP configurable, accessory relay is provided that can be cycled with the compressor 1 or 2, blower, or the Dehumidifier (DH) input. This is to complement the Accessory 1 Relay on the ABC board.

Position	DIP 4	DIP 5	Description
1	ON	ON	Cycles with Fan or ECM (or G)
2	OFF	ON	Cycles with CC1 first stage of compressor or compressor spd 1-6
3	ON	OFF	Cycles with CC2 second stage of compressor or compressor spd 7-12
4	OFF	OFF	Cycles with DH input from ABC board

Advanced Hot Water Generator Control (Domestic Hot Water Option)

In lieu of the 'Base Hot Water Generator Control', the Advanced features an AID Tool selectable temperature limit and microprocessor control of the process. This will maximize hot water generation and prevent undesirable energy use. An alert will occur when the hot water input temperature is at or above setpoint (100°F - 140°F) for 30 continuous seconds (130°F is the default setting). This alert will appear as an E15 on the AID Tool and the hot water pump de-energizes. Hot water pump operations resume on the next compressor cycle or after 15 minutes of continuous compressor operation during

the current thermostat demand cycle. Since compressor hot gas temperature is dependent on loop temperature in cooling mode, loop temperatures may be too low to allow proper heating of water. The control will monitor water and refrigerant temperatures to determine if conditions are satisfactory for heating water. LED1 (red LED) will flash code 15 when the DHW limit is reached and when conditions are not favorable for water heating. Error code 15 will also be displayed on the AID Tool in the fault screen. This flash code is a noncritical alert and does not necessarily indicate a problem.

Compressor Monitoring

The AXB includes two current transducers to monitor the compressor current and starting characteristics. Open circuits or welded contactor faults will be detected. A fault will produce an E10 code.

IntelliZone2 Zoning Compatibility (Optional IntelliZone2 Communicating Zoning)

A dedicated input to connect and communicate with the IntelliZone2 (IZ2) zoning system is necessary. With the split systems using the Aurora controls this can be accomplished by connecting the IZ2 to P7 on the compressor section AXB or P7 on the Air Handler AHB. These ports are dedicated for communicating proprietary ModBus protocol and only one of these boards is necessary for compatibility with the IZ2.

AWL - Aurora Weblink (optional accessory)

AWL is an add-on WiFi router that connects to the ABC and offers many features:

- Remote access to thermostat settings, schedules, etc. with your smartphone, tablet or laptop
- Receive Lockout/Fault info via text or e-mail
- View heat pump energy usage from the Internet for the day, week, month, year or real-time
- Internet AID Tool capability allows remote troubleshooting for the technician
- Remote AID Tool capability at the heat pump with smartphone, tablet or laptop for the technician
- Allows data acquisition of the heat pump through the Internet, see graphs of performance and chart historical data for the technician
- Stores historical data on SD card

Variable Speed Pump

This input and output are provided to drive and monitor a variable speed pump. The VS pump output is a PWM signal to drive the variable speed pump. The minimum and maximum level are set using the AID Tool. 75% and 100% are the default settings respectively. The VS data input allows a separate PWM signal to return from the pump giving fault and performance information. Fault received from the variable speed pump will be displayed as E16.

The Aurora 'Advanced' Control System cont.

Modulating Water Valve

This output is provided to drive a modulating water valve (only compatible with our 4MWVK or WWKVS) Through advanced design the 0-10VDC valve can be driven directly from the VS pump output. The minimum and maximum level are set in the same way as the VS pump using the AID Tool. 75% and 100% are the default settings respectively.

Loop Pump Linking

This input and output are provided so that two units can be linked together with a common flow center. When either unit has a call for loop pump, both unit's loop pump relays and variable speed pumps are energized. The flow center then can simply be wired to either unit. The output from one unit should be routed to the input of the other. If daisy chained up to 16 heat pumps can be wired and linked together in this fashion.

Advanced Communication Ports

Communication ports P6 and P8 will provide future expansion via dedicated protocols. These are for future use.

Smart Grid-On Peak (SG) Input

The 'On Peak' input was designed to allow utilities to utilize simple radio controlled switches to control the On Electric Peak behavior of the 5 and 7 Series Geothermal Heat Pumps. With a closed contact signal, this input will limit the operation and thus the power consumption of the unit by one of the below selections. The AID Tool will allow configuration of this input for the action of:

- No Action
- Disable compressor operation until removed
- Go to On Peak thermostat settings until removed [Requires Com T-Stat] (Future Release)
- Compressor limited to 50% or low cap until removed [dual capacity or variable speed only] (Future Release)
- Disable compressor operation for 1/2 hr (can be removed immediately) (Future Release)

Then Flash Code 7 on the Green LED for the 'On Peak' mode. And On Peak will display on communicating thermostats.

Home Automation 1 and 2 Inputs

The Home automation inputs are simple closed contact inputs that will trigger an AID Tool and thermostat alert for the homeowner. These would require optional sensors and or equipment for connection to the AXB board. With two inputs two different sensors can be selected. The selected text will then be displayed on the AID Tool and communicating thermostats. These events will NOT alter functionality or operation of the heat pump/accessories and is for homeowner/ service notification only.

Home Automation 1 - E23 HA1

With a closed dry contact signal, this input will cause an alarm and Alert Code 23 to indicate on the stat or flash on ABC. The AID Tool will allow configuration of this input between the following selections:

- No Action
- Home Automation Fault [no lockout info only]
 - Output from home automation system
- Security Alarm [no lockout info only]
 - Output from home security
- Sump Alarm Fault [no lockout info only]
 - Switch output from sump sensor
- Smoke/CO Alarm Fault [no lockout info only]
 - Switch output from Smoke/CO sensor
- Dirty Filter Alarm [no lockout info only]
 - Output from dirty filter sensor

Home Automation 2 - E24 HA2

With a closed dry contact signal, this input will cause an alarm and Alert Code 24 to indicate on the stat or flash on ABC. The AID Tool will allow configuration of this input between the following selections:

- No Action
- Home Automation Fault [no lockout info only]
 - Output from home automation system
- Security Alarm [no lockout info only]
 - Output from home security
- Sump Alarm Fault [no lockout info only]
 - Switch output from sump sensor
- Smoke/CO Alarm Fault [no lockout info only]
 - Switch output from Smoke/CO sensor
- Dirty Filter Alarm [no lockout info only]
 - Output from dirty filter sensor

Monitoring Sensor Kits

Energy Monitoring (Standard Sensor Kit on 'Advanced' models)

The Energy Monitoring Kit uses the existing two compressor sensors so that the power usage of the heat pump can be measured. Control option 'C' in the SAH Series Air handler has the necessary sensors for measuring power consumption of the blower motor and auxiliary heat. So for viewing total power usage the compressor section will need control options B, C, or D and the SAH Series Air Handler will need to be ordered with control option C. The AID Tool provides configuration detail for the power adjustment and a line voltage calibration procedure to improve the accuracy, and a power adjustment setting that allows the compressor power to be adjusted to match the unit's line voltage using the provided tables. This information can be displayed on the AID Tool or selected communicating thermostats. The TPCM32U03A/O4A will display instantaneous energy use while the color touchscreen TPCC32U01 will in addition display a 13 month history in graph form. Refer to Unit Start Up Energy Monitoring for configuration details.

Single Speed Power Adjustment

Model	Voltage		
	208	230	250
022	0.99	0.99	0.95
030	0.99	0.99	0.94
036	0.99	0.99	0.93
042	0.99	0.98	0.92
048	0.99	0.97	0.90
060	0.98	0.96	0.87
070	0.96	0.88	0.85

The Aurora 'Advanced' Control System cont.

Dual Capacity Power Adjustment

Model	Unit Capacity	Voltage		
		208	230	250
026	Full Load	0.99	0.99	0.96
	Part Load	0.99	0.99	0.93
038	Full Load	0.99	0.97	0.91
	Part Load	0.99	0.94	0.83
049	Full Load	0.94	0.91	0.85
	Part Load	0.91	0.84	0.75
064	Full Load	0.95	0.9	0.79
	Part Load	0.92	0.83	0.71
072	Full Load	0.94	0.86	0.73
	Part Load	0.92	0.81	0.65

Refrigerant Monitoring (optional sensor kit)

The optional Refrigerant Monitoring Kit includes two pressure transducers, and two temperature sensors, heating liquid line, suction temperature and existing cooling liquid line (FP1). These sensors allow the measurement of discharge and suction pressures, suction and liquid line temperatures as well as superheat and subcooling. This information will only be displayed on the AID Tool.

Performance Monitoring (optional sensor kit)

The optional Performance Monitoring Kit includes two temperature sensors, entering and leaving water and a water flow rate sensor. With this kit heat of extraction and rejection will be calculated. This requires configuration using the AID Tool for selection of water or antifreeze. The SAH Air Handler when ordered with control option C will include the LAT (leaving air temperature) sensor.

Special Modes and Applications Communicating Digital Thermostats

The Aurora controls system also features either mono-chromatic or color touch screen graphic display thermostats for user interface. These displays not only feature easy to use graphical interface but display alerts and faults in plain English. Many of the features discussed here may not be applicable without these thermostats.

Aurora 'Advanced' Control LED Displays

These three LEDs display the status, configuration, and fault codes for the control. These can also be read in plain English via the Aurora AID Tool.

Status LED (LED3, Green)

Description of Operation	Fault LED, Green
Normal Mode	ON
Control is Non-functional	OFF
Test Mode	Slow Flash
Lockout Active	Fast Flash
Dehumidification Mode	Flash Code 2
Load Shed	Flash Code 5
Emergency Shutdown	Flash Code 6
On Peak Mode	Flash Code 7
(Future Use)	Flash Code 8
(Future Use)	Flash Code 9

Configuration LED (LED2, Yellow)

Description of Operation	Configuration LED, Yellow
No Software Overwritten	ECM Setting
DIP Switch Overwritten	Slow Flash
ECM Configuration Mode	Fast Flash
Reset Configuration Mode	OFF

Fault LED (LED1, Red)

	Red Fault LED	LED Flash Code *	Lockout	Reset/ Remove	Fault Condition Summary
ABC Basic Faults	Normal - No Faults	Off	-		
	Fault-Input	1	No	Auto	Tstat input error. Autoreset upon condition removal.
	Fault-High Pressure	2	Yes	Hard or Soft	HP switch has tripped (>600 psi)
	Fault-Low Pressure	3	Yes	Hard or Soft	Low Pressure Switch has tripped (<40 psi for 30 continuous sec.)
	Fault-Freeze Detection FP2	4	Yes	Hard or Soft	Freeze protection sensor has tripped (<15 or 30 degF for 30 continuous sec.)
	Fault-Freeze Detection FP1	5	Yes	Hard or Soft	Freeze protection sensor has tripped (<15 or 30 degF for 30 continuous sec.)
	Fault-Condensate Overflow	7	Yes	Hard or Soft	Condensate switch has shown continuity for 30 continuous sec.
	Fault-Over/Under Voltage	8	No	Auto	Instantaneous voltage is out of range. **Controls shut down until resolved.
ABC & AXB Advanced	Fault-FP1 Sensor Error	11	Yes	Hard or Soft	FP1 Sensor Open or Shorted
	Fault-Compressor Monitor	10	Yes	Hard or Soft	Open Crkt, Run, Start or welded cont
	Non-CriticAXB SnSrErr	13	No	Auto	Any Other Sensor Error
	CriticAXBSnSrErr	14	Yes	Hard or Soft	Sensor Error for EEV or HW
	Alert-HotWtr	15	No	Auto	HW over limit or logic lockout. HW pump deactivated.
	Fault-VarSpdPump	16	No	Auto	Alert is read from PWM feedback.
	Non-CritComErr	18	No	Auto	Any non-critical com error
	Fault-CritComErr	19	No	Auto	Any critical com error. Auto reset upon condition removal
	Alarm - Low Loop Pressure	21	No	Auto	Loop pressure is below 3 psi for more than 3 minutes
	Alarm - Home Automation 1	23	No	Auto	Closed contact input is present on Dig 2 input - Text is configurable
	Alarm - Home Automation 2	24	No	Auto	Closed contact input is present on Dig 3 input - Text is configurable

NOTES:

*All codes >11 use long flash for tens digit and short flash for the ones digit. 20, 30, 40, 50 etc. are skipped!

Alert* is a noncritical sensor or function that has failed. Normal operation of the heat pump is maintained but service is desired at some point.

Water Quality

In ground water situations where scaling could be heavy or where biological growth such as iron bacteria will be present, a closed loop system is recommended. The heat exchanger coils in ground water systems may, over a period of time, lose heat exchange capabilities due to a buildup of mineral deposits inside. These can be cleaned, but only by a qualified service mechanic, as special solutions and pumping equipment are required. Hot water generator coils can likewise become scaled and possibly plugged. In areas

with extremely hard water, the owner should be informed that the heat exchanger may require occasional flushing.

Units with cupronickel heat exchangers are recommended for open loop applications due to the increased resistance to build-up and corrosion, along with reduced wear caused by acid cleaning. Failure to adhere to the guidelines in the water quality table could result in the loss of warranty.

Material		Copper	90/10 Cupronickel	316 Stainless Steel
pH	Acidity/Alkalinity	7 - 9	7 - 9	7 - 9
Scaling	Calcium and Magnesium Carbonate	(Total Hardness) less than 350 ppm	(Total Hardness) less than 350 ppm	(Total Hardness) less than 350 ppm
Corrosion	Hydrogen Sulfide	Less than 0.5 ppm (rotten egg smell appears at 0.5 ppm)	10 - 50 ppm	Less than 1 ppm
	Sulfates	Less than 125 ppm	Less than 125 ppm	Less than 200 ppm
	Chlorine	Less than 0.5 ppm	Less than 0.5 ppm	Less than 0.5 ppm
	Chlorides	Less than 20 ppm	Less than 125 ppm	Less than 300 ppm
	Carbon Dioxide	Less than 50 ppm	10 - 50 ppm	10 - 50 ppm
	Ammonia	Less than 2 ppm	Less than 2 ppm	Less than 20 ppm
	Ammonia Chloride	Less than 0.5 ppm	Less than 0.5 ppm	Less than 0.5 ppm
	Ammonia Nitrate	Less than 0.5 ppm	Less than 0.5 ppm	Less than 0.5 ppm
	Ammonia Hydroxide	Less than 0.5 ppm	Less than 0.5 ppm	Less than 0.5 ppm
	Ammonia Sulfate	Less than 0.5 ppm	Less than 0.5 ppm	Less than 0.5 ppm
	Total Dissolved Solids (TDS)	Less than 1000 ppm	1000 - 1500 ppm	1000 - 1500 ppm
	LSI Index	+0.5 to -0.5	+0.5 to -0.5	+0.5 to -0.5
Iron Fouling (Biological Growth)	Iron, FE ²⁺ (Ferrous) Bacterial Iron Potential	< 0.2 ppm	< 0.2 ppm	< 0.2 ppm
	Iron Oxide	Less than 1 ppm, above this level deposition will occur	Less than 1 ppm, above this level deposition will occur	Less than 1 ppm, above this level deposition will occur
Erosion	Suspended Solids	Less than 10 ppm and filtered for max. of 600 micron size	Less than 10 ppm and filtered for max. of 600 micron size	Less than 10 ppm and filtered for max. of 600 micron size
	Threshold Velocity (Fresh Water)	< 6 ft/sec	< 6 ft/sec	< 6 ft/sec

NOTES: Grains = ppm divided by 17
mg/L is equivalent to ppm

2/22/12

Dimensional Data

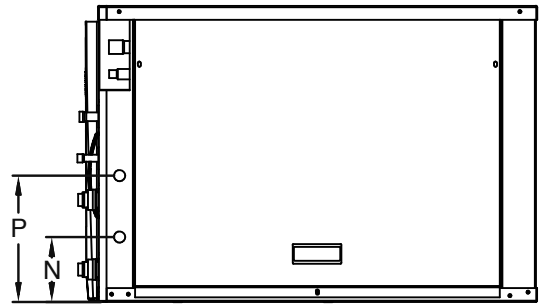
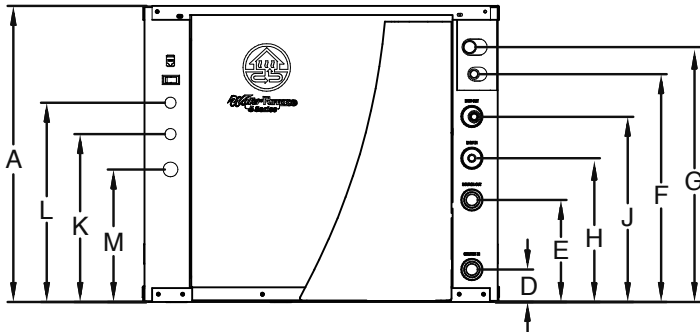
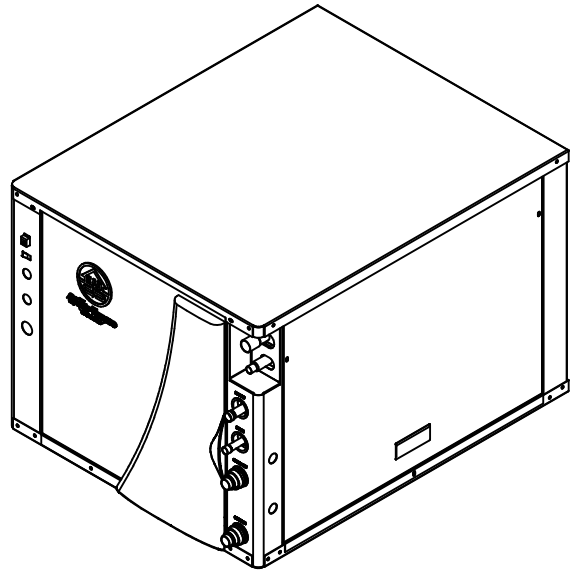
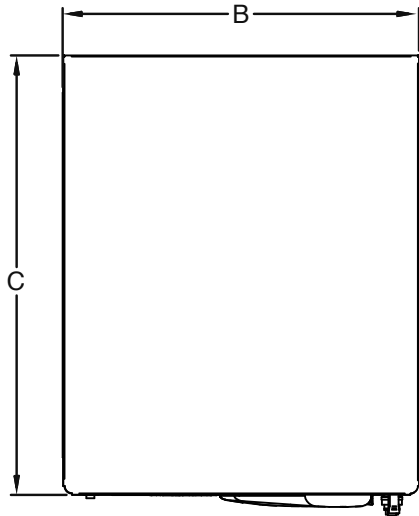

Models		Height	Width	Depth	Water In	Water Out	Service Valve		HWG In	HWG Out	Low Voltage	External Pump	Line Voltage	Knock Out	Knock Out
							Liquid	Gas							
		A	B	C	D	E	F	G	H	J	K	L	M	N	P
022-030	in.	19.30	22.50	26.50	1.93	6.93	15.20	16.80	9.40	11.90	12.10	14.30	9.50	4.60	8.20
	cm.	49.00	57.10	67.30	4.90	17.60	38.60	42.70	23.90	30.20	30.70	36.30	24.10	11.70	20.80
036-072	in.	21.25	25.62	31.60	2.30	7.21	16.40	18.30	10.30	13.30	12.10	14.30	9.50	4.70	9.10
	cm.	54.00	65.10	80.30	5.80	18.50	41.70	46.50	26.20	33.80	30.70	36.30	24.10	11.90	23.10

Dimensions are in inches.
Decorative molding and water connections extend 1.2 in. [30.5 mm] beyond the front of the cabinet.

Physical Data

Model	022	030	036	042	048	060	070	026	038	049	064	72
Compressor (1 each)	Single Speed Scroll							Dual Capacity Scroll				
Factory Charge R410a, oz [kg]	56 [1.59]	56 [1.59]	56 [1.59]	74 [2.1]	90 [2.55]	92 [2.61]	108 [3.06]	52 [1.47]	56 [1.59]	90 [2.55]	92 [2.61]	104 [2.95]
Coax and Water Piping												
Water Connections Size - Swivel- in [mm]	1 [25.4]							1 [25.4]				
HWG Connection Size - Female Sweat (I.D.) - in [mm]	1/2 [12.7]							1/2 [12.7]				
Brass Service Valve - Liquid Line - in [mm]	3/8 [9.525]					1/2 [12.7]		3/8 [9.525]			1/2 [12.7]	
Brass Service Valve - Suction Line - in [mm]	5/8 [15.875]			3/4 [19.05]		7/8 [22.225]		5/8 [15.875]		3/4 [19.05]		7/8 [22.225]
Coax and Piping Water Volume - gal [l]	0.7 [2.6]	1.0 [3.8]	1.3 [4.9]	1.3 [4.9]	1.6 [6.1]	1.6 [6.1]	2.3 [8.7]	0.7 [2.6]	1.3 [4.9]	1.6 [6.1]	1.6 [6.1]	2.3 [8.7]
Weight - Operating, lb [kg]	164 [74]	174 [79]	212 [96]	213 [97]	246 [112]	251 [114]	292 [132]	189 [86]	236 [107]	250 [113]	271 [123]	290 [132]
Weight - Packaged, lb [kg]	184 [83]	194 [88]	232 [105]	233 [106]	266 [121]	271 [123]	312 [142]	209 [95]	256 [116]	270 [122]	291 [132]	310 [141]

NOTES: All units have TXV expansion devices, and 1/2 in. [12.2 mm] and 3/4 in. [19.1 mm] electrical knockouts.
Brass service valves are sweat type valves.

6/27/11

Electrical Data

Model	Rated Voltage	Voltage Min/Max	Compressor				HWA Pump FLA	Ext Loop FLA	Total Unit FLA	Min Circ Amp	Max Fuse/HACR
			MCC	RLA	LRA	LRA*					
022	208-230/60/1	187/253	14.0	9.0	48.0	17.0	0.4	5.4	14.8	17.1	25
030	208-230/60/1	187/253	20.0	12.8	58.3	21.0	0.4	5.4	18.6	21.8	30
036	208-230/60/1	187/253	22.0	14.1	73.0	26.0	0.4	5.4	19.9	23.4	35
042	208-230/60/1	187/253	26.0	16.6	79.0	28.0	0.4	5.4	22.4	26.6	40
048	208-230/60/1	187/253	31.0	19.8	109.0	38.0	0.4	5.4	25.6	30.6	50
060	208-230/60/1	187/253	41.2	26.4	134.0	47.0	0.4	5.4	32.2	38.8	60
070	208-230/60/1	187/253	44.2	28.3	158.0	63.0	0.4	5.4	34.1	41.2	70
026	208-230/60/1	187/253	18.2	11.6	58.3	21.0	0.4	5.4	17.4	20.3	30
038	208-230/60/1	187/253	23.8	15.2	83.0	30.0	0.4	5.4	21.0	24.8	40
049	208-230/60/1	187/253	33.0	21.1	104.0	37.0	0.4	5.4	26.9	32.2	50
064	208-230/60/1	187/253	42.3	27.1	152.9	54.0	0.4	5.4	32.9	39.7	70
072	208-230/60/1	187/253	46.3	29.6	179.2	63.0	0.4	5.4	35.4	42.8	75

Rated voltage of 208-230/60/1
HACR circuit breaker in USA only
All fuses Class RK-5

* With optional IntelliStart

4/3/13

Model Nomenclature - Air Handler

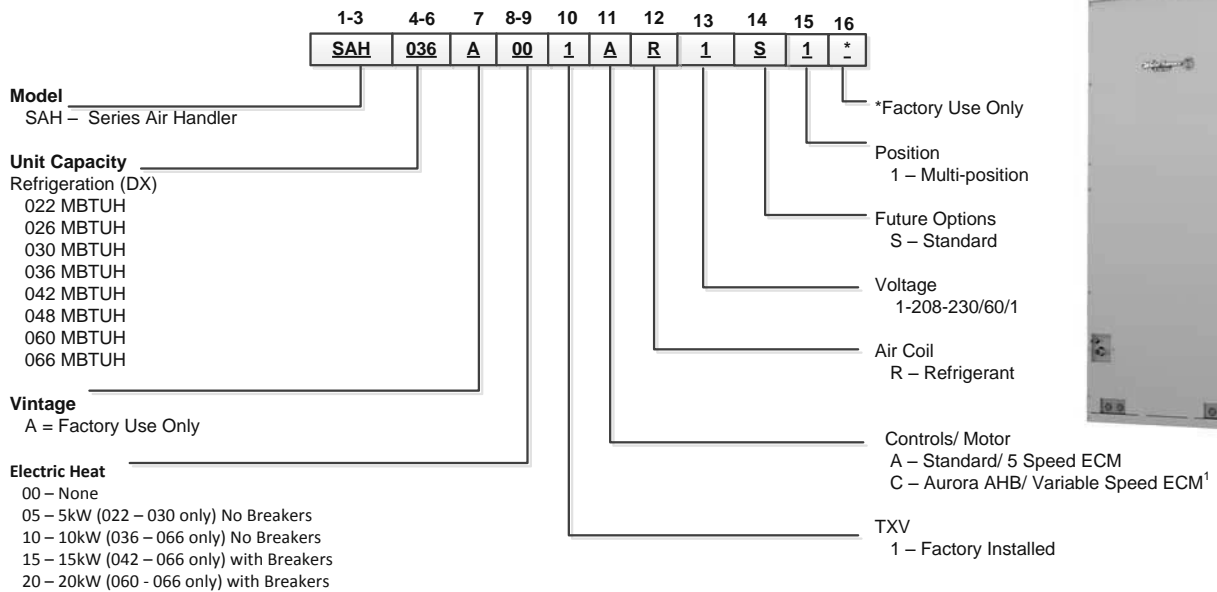

Note: To field convert the SAH to bottomflow air discharge. The SAHBCK kit must be ordered separately.
 Note: Air flow on the 060 and 066 units in the horizontal configurations should be limited to 1900 cfm in cooling mode, or condensate blow off may occur.

Rev.: 2/27/2017

1. Only available with Aurora controls in the compressor section.

Compatibility Table - Air Handler

Air Handler Sizing Selection

The Air Handlers are designed for R-410A refrigerant and should be matched with split compressor section according to the table below.

Air Handler	Indoor Split Model (Single)	Indoor Split Model (Dual Capacity)	Outdoor Split Model (Dual Capacity)	Rated Airflow(CFM)	Electric Heat (kW)
SAH022***1*R1S1*	022	-		800	5
SAH026***1*R1S1*	-	026	026	850	5
SAH030***1*R1S1*	030	-	-	1000	5
SAH036***1*R1S1*	036	-	-	1200	5, 10
SAH036***1*R1S1*	-	038	038	1200	5, 10
SAH042***1*R1S1*	042	-	-	1300	10, 15
SAH048***1*R1S1*	048	-	-	1500	10, 15
SAH048***1*R1S1*	-	049	049	1500	10, 15
SAH060***1*R1S1*	060	-	-	1800	10, 15, 20
SAH060***1*R1S1*	-	064	064	1800	10, 15, 20
SAH066***1*R1S1*	070	-	-	2000	10, 15, 20
SAH066***1*R1S1*	-	072	072	2000	10, 15, 20

1/31/2017

Physical Data - Air Handler

Air Handler Model Number (Refrigerant)		022	026	030	036	042	048	060	066
Evaporator Coil	Air Coil Total Face Area, ft ² [m ²]	3.89 [0.36]			4.86 [0.45]	5.83 [0.54]		6.81 [0.63]	
	Tube outside diameter - in. [mm]	3/8 [9.52]							
	Number of rows	3							
	Fins per inch	12							
	Suction line connection - in. [mm] sweat	5/8 [15.87]			3/4 [19.05]			7/8 [22.23]	
Liquid line connection - in. [mm] sweat	3/8 [9.52]							1/2 [12.7]	
Refrigerant	R-410a								
Nominal cooling capacity - tons [kW]	1.8 [6.44]	2.1 [7.59]	2.5 [8.79]	3 [10.55]	3.5 [12.30]	4 [14.06]	5 [17.58]	5.5 [19.33]	
Condensate drain connection - (FPT) in. [mm]	3/4 [19.05]								
Blower Wheel Size (Dia x W), in. [mm]	9 X 7 [229 x 178]			10 X 8 [254 x 203]		11 x 10 [279 x 254]			
Blower motor type/speeds	Variable Speed ECM/ 5 Speed ECM								
Blower motor output - hp [W]	1/2 [373]					1 [746]			
Filter Standard - 1" [51mm] Field Supplied.	16 X 20 [406 X 508]			20 X 20 [508 x 508]		22 X 20 [559 x 508]			
Electrical characteristics (60hz)	208/230 - 1ph								
Shipping weight - lbs. [kg]	147 [66.7]			168 [76.2]		198 [89.6]		206 [93.4]	
Operating weight - lbs. [kg]	139 [63.0]			150 [68.0]		180 [81.6]		188 [85.3]	

1/31/2017

Line Set Sizes

Unit Size	Air Handler	20 feet		40 feet		60 feet		NZ Factory Charge (oz.)	*Charge Amount with SAH Air Handler (oz.)
		Suction	Liquid	Suction	Liquid	Suction	Liquid		
022	SAH022	5/8" OD	3/8" OD	5/8" OD	3/8" OD	3/4" OD	3/8" OD	56	76
030	SAH030	5/8" OD	3/8" OD	3/4" OD	3/8" OD	3/4" OD	3/8" OD	56	82
036	SAH036	5/8" OD	3/8" OD	3/4" OD	3/8" OD	3/4" OD	1/2" OD	56	96
042	SAH042	3/4" OD	3/8" OD	3/4" OD	3/8" OD	7/8" OD	1/2" OD	74	104
048	SAH048	3/4" OD	3/8" OD	7/8" OD	3/8" OD	7/8" OD	1/2" OD	90	112
060	SAH060	7/8" OD	1/2" OD	7/8" OD	1/2" OD	1-1/8" OD	1/2" OD	92	119
070	SAH066	7/8" OD	1/2" OD	7/8" OD	1/2" OD	1-1/8" OD	1/2" OD	108	135
026	SAH026	5/8" OD	3/8" OD	3/4" OD	3/8" OD	3/4" OD	1/2" OD	52	72
038	SAH036	5/8" OD	3/8" OD	3/4" OD	3/8" OD	3/4" OD	1/2" OD	56	96
049	SAH048	3/4" OD	3/8" OD	7/8" OD	3/8" OD	7/8" OD	1/2" OD	90	112
064	SAH060	7/8" OD	1/2" OD	7/8" OD	1/2" OD	1-1/8" OD	1/2" OD	96	119
072	SAH066	7/8" OD	1/2" OD	7/8" OD	1/2" OD	1-1/8" OD	1/2" OD	104	133

Notes: * The "Charge Amount with SAH Air Handler" column is based on the charge amount for a SAH Air Handler + Compressor Section/Split.

Additional charge will need to be added accordingly for line set length.

After charge is added, additional adjustments can be made to get appropriate subcooling and superheat measurements.

Additional charge for R410A is 0.50 oz. per ft. for 3/8" and 1.0 oz. per ft. for 1/2" tube.

Longer line sets will significantly reduce capacity and efficiency of the system as well as adversely effect the system reliability due to poor oil return.

1/13/2017

Model Nomenclature - Coil

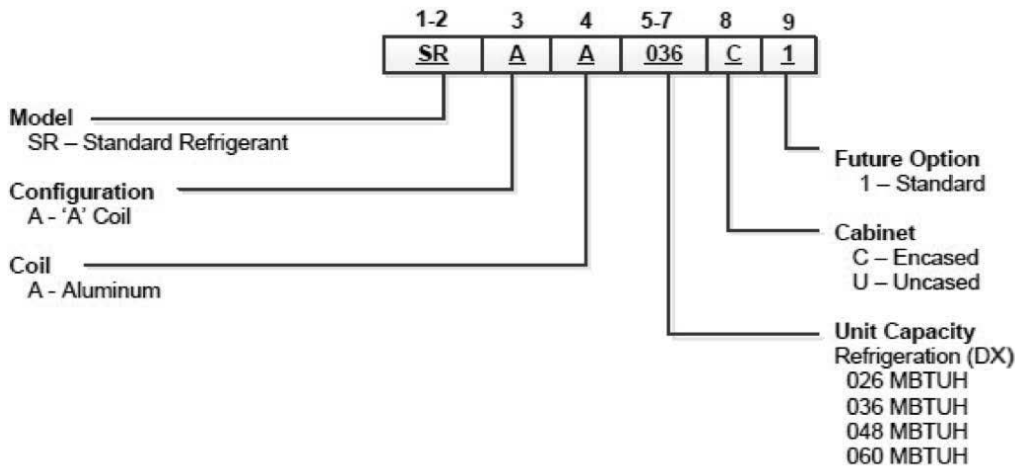

Refrigerant Coil Compatibility

Encased/Uncased Coil	Indoor Split Model (Single)	Indoor Split Model (Dual Capacity)	Outdoor Split Model (Dual Capacity)	Recommended Airflow (CFM)
SR**026C*	NSZ022	-		800
SR**026C*	-	NDZ026	NDS026	850
SR**026C*	NSZ030	-	-	1000
SR**036C*	NSZ036	-	-	1200
SR**036C*	-	NDZ038	NDS038	1200
SR**048C*	NSZ042	-	-	1300
SR**048C*	NSZ048	-	-	1500
SR**048C*	-	NDZ049	NDS049	1500
SR**060C*	NSZ060	-	-	1800
SR**060C*	-	NDZ064	NDS064	1800
SR**060C*	NSZ070	-	-	2000
SR**060C*	-	NDZ072	NDS072	2000

1/10/2017

SR Coil Physical Characteristics

Air Handler Model Number (Refrigerant)		026			036	048		060	
Evaporator Coil	Air Coil Total Face Area, ft2 [m2]	3.89 [0.36]			4.86 [0.45]	5.83 [0.54]		6.81 [0.63]	
	Tube outside diameter - in. [mm]	3/8 [9.52]							
	Number of rows	3							
	Fins per inch	12							
	Suction line connection - in. [mm] sweat	5/8 [15.87]			3/4 [19.05]		7/8 [22.23]		
	Liquid line connection - in. [mm] sweat	3/8 [9.52]						1/2 [12.7]	
Refrigerant		R-410a							
Nominal cooling capacity - tons [kW]		1.8 [6.44]	2.1 [7.59]	2.5 [8.79]	3 [10.55]	3.5 [12.30]	4 [14.06]	5 [17.58]	5.5 [19.33]
Condensate drain connection - (FPT) in. [mm]		3/4 [19.05]							
Filter Standard - 1" [51mm] Field Supplied.		16 X 20 [406 X 508]			20 X 20 [508 x 508]		22 X 20 [559 x 508]		

3/7/17

Reference Calculations

Heating Calculations:	Cooling Calculations:
$LWT = EWT - \frac{HE}{gpm \times 500}$	$LWT = EWT + \frac{HR}{gpm \times 500}$
$LAT = EAT + \frac{HC}{cfm \times 1.08}$	$LAT(DB) = EAT(DB) - \frac{SC}{cfm \times 1.08}$
$TH = HC + HWC$	$LC = TC - SC$
	$S/T = \frac{SC}{TC}$

Legend and Notes

ABBREVIATIONS AND DEFINITIONS:

cfm = airflow, cubic feet/minute	HE = total heat of extraction, MBtu/h
EWT = entering water temperature, Fahrenheit	HWC = hot water generator capacity, MBtu/h
gpm = water flow in gallons/minute	EER = Energy Efficient Ratio
WPD = water pressure drop, PSI and feet of water	= Btu output/Watt input
EAT = entering air temperature, Fahrenheit (dry bulb/wet bulb)	COP = Coefficient of Performance
HC = air heating capacity, MBtu/h	= Btu output/Btu input
TC = total cooling capacity, MBtu/h	LWT = leaving water temperature, °F
SC = sensible cooling capacity, MBtu/h	LAT = leaving air temperature, °F
kW = total power unit input, kilowatts	TH = total heating capacity, MBtu/h
HR = total heat of rejection, MBtu/h	LC = latent cooling capacity, MBtu/h
	S/T = sensible to total cooling ratio

Hot water generator capacity based on 0.4 gpm flow per nominal unit ton at 90°F entering hot water temperature. Performance Data tables do not include water pumping watts and are based upon 15% (by volume) methanol antifreeze solution. Multiple Flow Rates (for EWT) are shown in the Performance Data tables. The lowest flow rate shown is used for geothermal open loop/well water systems with a minimum 50° F. The second flow rate shown is the minimum geothermal closed loop flow rate. The third flow rate shown is optimum for geothermal closed loop and the suggested flow rate for boiler tower applications. Interpolation between EWT, gpm and cfm data is permissible. Extrapolation for heating data down to 25°F is permissible. Catalog illustrations cover the general appearance of products at time of publication. We reserve the right to make changes in design and construction at any time without notice.

Operating Limits

Operating Limits	Cooling		Heating	
	(°F)	(°C)	(°F)	(°C)
Air Limits				
Min. Ambient Air	45	7.2	45	7.2
Rated Ambient Air	80	26.7	70	21.1
Max. Ambient Air	100	37.8	85	29.4
Min. Entering Air	50	10.0	40	4.4
Rated Entering Air db/wb	80.6/66.2	27/19	68	20.0
Max. Entering Air db/wb	110/83	43/28.3	80	26.7
Water Limits				
Min. Entering Water	30	-1.1	20	-6.7
Normal Entering Water	50-110	10-43.3	30-70	-1.1
Max. Entering Water	120	48.9	90	32.2

NOTE: Minimum/maximum limits are only for start-up conditions, and are meant for bringing the space up to occupancy temperature. Units are not designed to operate at the minimum/maximum conditions on a regular basis. The operating limits are dependant upon three primary factors: 1) water temperature, 2) return air temperature, and 3) ambient temperature. When any of the factors are at the minimum or maximum levels, the other two factors must be at the normal level for proper and reliable unit operation.

Antifreeze Corrections

Catalog performance can be corrected for antifreeze use. Please use the following table and note the example given.

Antifreeze Type	Antifreeze % by wt	Heating	Cooling	Pressure Drop
EWT - °F [°C]		30 [-1.1]	90 [32.2]	30 [-1.1]
Water	0	1.000	1.000	1.000
	10	0.973	0.991	1.075
Ethylene Glycol	20	0.943	0.979	1.163
	30	0.917	0.965	1.225
	40	0.890	0.955	1.324
	50	0.865	0.943	1.419
	10	0.958	0.981	1.130
Propylene Glycol	20	0.913	0.969	1.270
	30	0.854	0.950	1.433
	40	0.813	0.937	1.614
	50	0.770	0.922	1.816
	10	0.927	0.991	1.242
Ethanol	20	0.887	0.972	1.343
	30	0.856	0.947	1.383
	40	0.815	0.930	1.523
	50	0.779	0.911	1.639
	10	0.957	0.986	1.127
Methanol	20	0.924	0.970	1.197
	30	0.895	0.951	1.235
	40	0.863	0.936	1.323
	50	0.833	0.920	1.399



WARNING: Gray area represents antifreeze concentrations greater than 35% by weight and should be avoided due to the extreme performance penalty they represent.

Antifreeze Correction Example

Antifreeze solution is Propylene Glycol 20% by weight. Determine the corrected heating and cooling performance at 30°F and 90°F respectively as well as pressure drop at 30°F for a 5 Series NS*022.

The corrected cooling capacity at 90°F would be: 18,400 MBtu/h x 0.969 = 17,830 MBtu/h

The corrected heating capacity at 30°F would be: 14,900 MBtu/h x 0.913 = 13,604 MBtu/h

The corrected pressure drop at 30°F and 6 gpm would be: 7.1 feet of head x 1.270 = 9.01 feet of head

Correction Factor Tables

Air Flow Corrections (Dual Capacity Part Load)

Airflow		Cooling				Heating		
cfm Per Ton of Clg	% of Nominal	Total Cap	Sens Cap	Power	Heat of Rej	Htg Cap	Power	Heat of Ext
240	60	0.922	0.778	0.956	0.924	0.943	1.239	0.879
275	69	0.944	0.830	0.962	0.944	0.958	1.161	0.914
300	75	0.957	0.866	0.968	0.958	0.968	1.115	0.937
325	81	0.970	0.900	0.974	0.970	0.977	1.075	0.956
350	88	0.982	0.933	0.981	0.980	0.985	1.042	0.972
375	94	0.991	0.968	0.991	0.991	0.993	1.018	0.988
400	100	1.000	1.000	1.000	1.000	1.000	1.000	1.000
425	106	1.007	1.033	1.011	1.008	1.007	0.990	1.010
450	113	1.013	1.065	1.023	1.015	1.012	0.987	1.018
475	119	1.017	1.099	1.037	1.022	1.018	0.984	1.025
500	125	1.020	1.132	1.052	1.027	1.022	0.982	1.031
520	130	1.022	1.159	1.064	1.030	1.025	0.979	1.034

1/5/17

Air Flow Corrections (Dual Capacity Full Load and Single Speed)

Airflow		Cooling				Heating		
cfm Per Ton of Clg	% of Nominal	Total Cap	Sens Cap	Power	Heat of Rej	Htg Cap	Power	Heat of Ext
240	60	0.922	0.786	0.910	0.920	0.943	1.150	0.893
275	69	0.944	0.827	0.924	0.940	0.958	1.105	0.922
300	75	0.959	0.860	0.937	0.955	0.968	1.078	0.942
325	81	0.971	0.894	0.950	0.967	0.977	1.053	0.959
350	88	0.982	0.929	0.964	0.978	0.985	1.031	0.973
375	94	0.992	0.965	0.982	0.990	0.993	1.014	0.988
400	100	1.000	1.000	1.000	1.000	1.000	1.000	1.000
425	106	1.007	1.034	1.020	1.010	1.007	0.990	1.011
450	113	1.012	1.065	1.042	1.018	1.013	0.983	1.020
475	119	1.017	1.093	1.066	1.026	1.018	0.980	1.028
500	125	1.019	1.117	1.092	1.033	1.023	0.978	1.034
520	130	1.020	1.132	1.113	1.038	1.026	0.975	1.038

1/5/17

Cooling Capacity Corrections

Entering Air WB °F	Total Clg Cap	Sensible Cooling Capacity Multipliers - Entering DB °F										Power Input	Heat of Rejection
		60	65	70	75	80	80.6	85	90	95	100		
55	0.898	0.723	0.866	1.048	1.185	*	*	*	*	*	*	0.985	0.913
60	0.912		0.632	0.880	1.078	1.244	1.260	*	*	*	*	0.994	0.927
63	0.945			0.768	0.960	1.150	1.175	*	*	*	*	0.996	0.954
65	0.976			0.694	0.881	1.079	1.085	1.270	*	*	*	0.997	0.972
66.2	0.983			0.655	0.842	1.040	1.060	1.232	*	*	*	0.999	0.986
67	1.000			0.616	0.806	1.000	1.023	1.193	1.330	1.480	*	1.000	1.000
70	1.053				0.693	0.879	0.900	1.075	1.205	1.404	*	1.003	1.044
75	1.168					0.687	0.715	0.875	1.040	1.261	1.476	1.007	1.141

NOTE: * Sensible capacity equals total capacity at conditions shown.

1/5/17

Heating Capacity Corrections

Ent Air DB °F	Heating Corrections		
	Htg Cap	Power	Heat of Ext
45	1.062	0.739	1.158
50	1.050	0.790	1.130
55	1.037	0.842	1.096
60	1.025	0.893	1.064
65	1.012	0.945	1.030
68	1.005	0.976	1.012
70	1.000	1.000	1.000
75	0.987	1.048	0.970
80	0.975	1.099	0.930

1/5/17

Pressure Drop

Single Speed

Model	GPM	Pressure Drop (psi)				
		30°F	50°F	70°F	90°F	110°F
022	3	1.0	0.1	0.9	0.8	0.8
	4.5	2.1	1.9	1.8	1.6	1.5
	6	3.2	2.9	2.7	2.4	2.3
	8	5.1	4.6	3.9	3.7	3.5
030	4	1.6	1.5	1.4	1.3	1.2
	6	3.2	3.0	2.8	2.6	2.4
	8	4.7	4.4	4.1	3.8	3.5
	10	7.0	6.5	5.6	5.5	5.1
036	5	1.6	1.5	1.4	1.3	1.2
	7	2.8	2.7	2.5	2.3	2.2
	9	4.2	3.9	3.7	3.4	3.2
	12	6.7	6.4	6.2	5.6	5.4
042	5	1.5	1.4	1.3	1.2	1.1
	8	3.5	3.3	3.1	2.9	2.7
	11	5.6	5.2	4.9	4.6	4.2
	14	8.1	7.9	7.6	7.3	7.0
048	6	1.3	1.2	1.1	1.0	1.0
	9	2.7	2.6	2.4	2.2	2.1
	12	4.1	3.9	3.6	3.4	3.1
	16	6.9	6.7	6.4	6.2	5.9
060	9	2.1	2.0	1.9	1.8	1.6
	12	3.9	3.6	3.4	3.2	2.9
	15	5.7	5.3	5.0	4.6	4.3
	20	9.5	8.9	8.3	7.8	7.2
070	12	3.3	3.1	2.9	2.7	2.5
	15	5.0	4.7	4.4	4.1	3.8
	18	6.7	6.3	5.9	5.5	5.1
	24	9.7	9.5	9.2	8.4	7.9

1/4/16

Dual Capacity

Model	GPM	Pressure Drop (psi)				
		30°F	50°F	70°F	90°F	110°F
026 full load	4	1.4	1.3	1.2	1.1	1.0
	6	3.3	3.1	2.9	2.7	2.5
	8	5.1	4.8	4.5	4.2	3.9
	10	7.2	6.9	6.6	6.3	6.0
026 part load	3	1.0	0.9	0.9	0.8	0.7
	5	2.5	2.3	2.2	2.0	1.9
	7	3.9	3.6	3.4	3.2	2.9
	9	6.2	5.9	5.7	5.5	5.2
038 full load	5	1.2	1.2	1.1	1.0	1.0
	7	2.5	2.3	2.2	2.0	1.9
	9	3.6	3.4	3.2	3.0	2.8
	11	5.2	5.0	4.8	4.6	4.4
038 part load	4	0.9	0.9	0.8	0.8	0.7
	6	2.0	1.9	1.8	1.7	1.6
	8	2.9	2.8	2.7	2.5	2.3
	10	4.1	4.0	3.8	3.6	3.4
049 full load	6	1.3	1.2	1.1	1.1	1.0
	9	2.7	2.6	2.4	2.2	2.1
	12	4.2	3.9	3.7	3.3	3.2
	15	6.0	5.7	5.5	5.2	5.0
049 part load	5	0.9	0.8	0.8	0.7	0.7
	8	2.2	2.0	1.9	1.7	1.6
	11	3.5	3.3	3.1	2.8	2.7
	14	5.1	4.9	4.7	4.4	4.2
064 full load	8	1.8	1.7	1.6	1.5	1.4
	12	4.1	3.8	3.6	3.4	3.1
	16	6.5	6.1	5.7	5.3	4.9
	20	9.7	9.2	8.6	8.2	7.6
064 part load	6	1.1	1.0	0.9	0.9	0.8
	10	3.3	3.1	2.9	2.7	2.5
	14	5.6	5.3	4.9	4.6	4.3
	18	8.4	8.1	7.7	7.4	7.1
072 full load	12	3.3	3.1	2.9	2.7	2.5
	15	5.0	4.7	4.4	4.1	3.8
	18	6.8	6.4	6.0	5.5	5.1
	21	8.4	8.0	7.6	7.1	6.8
072 part load	10	2.4	2.3	2.1	2.0	1.8
	13	4.0	3.7	3.5	3.3	3.0
	16	5.6	5.2	4.9	4.6	4.2
	19	7.1	6.8	6.5	6.2	5.9

1/4/17

022 - Performance Data

022 - Single Speed

EWT °F	Flow gpm	WPD		HEATING - EAT 70°F							COOLING - EAT 80/67 °F							
		PSI	FT	Airflow cfm	HC Mbtu/h	Power kW	HE Mbtu/h	LAT °F	COP	HWC Mbtu/h	Airflow cfm	TC Mbtu/h	SC Mbtu/h	S/T Ratio	Power kW	HR Mbtu/h	EER	HWC Mbtu/h
20	3.0	1.0	2.4	Operation not recommended							Operation not recommended							
	4.5	2.1	4.9	Operation not recommended							Operation not recommended							
	6.0	3.2	7.3	600	11.7	1.17	7.7	88.0	2.92	1.6	Operation not recommended							
30	3.0	1.0	2.3	Operation not recommended							Operation not recommended							
	4.5	2.0	4.7	600	13.4	1.15	9.5	90.7	3.43	1.7	600	19.2	11.5	0.60	0.67	21.5	28.8	-
	6.0	3.1	7.1	600	14.6	1.20	10.5	92.5	3.57	1.8	600	19.3	11.5	0.60	0.65	21.8	29.8	-
40	3.0	1.0	2.2	Operation not recommended							Operation not recommended							
	4.5	2.0	4.6	600	15.9	1.18	11.8	94.5	3.93	1.9	600	20.3	13.3	0.65	0.74	22.9	27.5	-
	6.0	3.0	6.9	600	16.7	1.21	12.6	95.8	4.04	2.0	600	20.5	13.3	0.65	0.72	22.9	28.6	-
50	3.0	0.9	2.1	600	17.7	1.22	13.5	97.2	4.26	2.1	600	21.0	14.4	0.69	0.83	23.8	25.2	1.1
	4.5	1.9	4.4	600	18.3	1.22	14.1	98.2	4.40	2.2	600	21.2	14.4	0.68	0.81	23.9	26.1	1.0
	6.0	2.9	6.7	600	19.1	1.25	14.9	99.5	4.50	2.2	600	21.5	14.8	0.69	0.80	24.2	26.7	1.0
60	3.0	0.9	2.1	600	20.1	1.26	15.4	96.1	4.58	2.1	600	22.1	16.4	0.74	0.82	24.9	27.0	1.1
	4.5	1.9	4.3	600	20.6	1.27	16.3	97.3	4.77	2.2	600	21.0	15.6	0.74	0.95	24.2	22.0	1.4
	6.0	2.8	6.5	600	20.9	1.26	16.7	102.3	4.89	2.4	600	20.6	14.2	0.69	0.91	23.7	22.6	1.2
70	3.0	0.9	2.0	600	21.4	1.26	17.1	98.3	4.97	2.3	600	21.2	15.7	0.74	0.93	24.3	22.8	1.3
	4.5	1.8	4.2	600	21.7	1.28	17.3	103.4	4.95	2.5	600	20.9	14.5	0.70	0.90	24.0	23.2	1.1
	6.0	2.7	6.3	600	22.2	1.29	17.7	99.3	5.03	2.3	600	21.5	16.1	0.75	0.92	24.6	23.4	1.3
80	3.0	0.8	1.9	600	22.6	1.30	18.1	104.8	5.09	2.7	600	19.8	13.8	0.70	1.04	23.4	19.1	1.6
	4.5	1.7	4.0	600	31.2	1.83	25.0	111.3	5.00	2.5	600	20.4	15.3	0.75	1.06	24.0	19.3	1.7
	6.0	2.6	6.0	600	23.6	1.29	19.2	106.4	5.34	2.7	600	20.0	13.9	0.70	1.01	23.5	19.8	1.5
90	3.0	0.8	1.9	600	24.0	1.29	19.6	101.8	5.44	2.5	600	20.6	15.4	0.75	1.03	24.1	20.0	1.7
	4.5	1.7	3.9	600	22.9	1.30	19.5	105.3	5.16	2.8	600	20.3	14.3	0.70	1.00	23.7	20.3	1.4
	6.0	2.5	5.8	600	24.6	1.32	20.1	102.5	5.46	2.6	600	20.9	15.8	0.76	1.02	24.4	20.5	1.6
100	3.0	0.8	1.9	600	24.8	1.34	20.2	108.3	5.42	3.0	600	18.6	13.6	0.73	1.17	22.6	16.0	2.0
	4.5	1.6	3.7	600	25.2	1.34	20.6	103.3	5.52	2.8	600	19.2	15.0	0.78	1.19	23.2	16.1	2.2
	6.0	2.4	5.6	600	26.0	1.33	21.5	110.1	5.71	3.1	600	18.8	13.7	0.73	1.14	22.7	16.5	1.9
110	3.0	0.8	1.7	600	26.3	1.32	21.8	104.8	5.82	2.8	600	19.3	15.1	0.78	1.16	23.3	16.7	2.1
	4.5	1.6	3.6	600	26.4	1.36	21.7	110.7	5.68	3.2	600	19.1	14.0	0.73	1.13	23.0	16.9	1.8
	6.0	2.3	5.4	600	26.7	1.35	22.0	105.3	5.79	2.9	600	19.7	15.5	0.79	1.15	23.6	17.1	2.0
120	3.0	0.7	1.7	600	27.1	1.39	22.3	111.7	5.72	3.3	600	17.5	13.3	0.76	1.30	21.9	13.4	2.5
	4.5	1.5	3.5	600	27.3	1.37	22.6	106.1	5.83	3.1	600	17.9	14.7	0.82	1.33	22.5	13.5	2.7
	6.0	2.2	5.2	600	28.4	1.37	23.8	113.9	6.06	3.4	600	17.6	13.4	0.76	1.27	22.1	13.9	2.4
100	3.0	0.8	1.8	600	28.6	1.40	23.8	114.1	5.97	3.5	600	18.1	14.0	0.77	1.26	22.4	14.4	2.2
	4.5	1.5	3.5	600	28.7	1.38	24.0	108.0	6.10	3.3	600	18.4	15.2	0.83	1.28	22.8	14.4	2.4
	6.0	2.2	5.2	Operation not recommended							Operation not recommended							
110	3.0	0.8	1.7	Operation not recommended							Operation not recommended							
	4.5	1.6	3.6	Operation not recommended							Operation not recommended							
	6.0	2.3	5.4	Operation not recommended							Operation not recommended							
120	3.0	0.7	1.7	Operation not recommended							Operation not recommended							
	4.5	1.5	3.5	Operation not recommended							Operation not recommended							
	6.0	2.2	5.2	Operation not recommended							Operation not recommended							

Multiple Flow Rates (for EWT) are shown in the table above. The lowest flow rate shown is used for geothermal open loop/well water systems with a minimum 50° F. The second flow rate shown is the minimum geothermal closed loop flow rate. The third flow rate shown is optimum for geothermal closed loop and the suggested flow rate for boiler tower applications.

3/7/17

030 - Performance Data

030 - Single Speed

EWT °F	Flow gpm	WPD		HEATING - EAT 70°F							COOLING - EAT 80/67 °F								
		PSI	FT	Airflow cfm	HC Mbtu/h	Power kW	HE Mbtu/h	LAT °F	COP	HWC Mbtu/h	Airflow cfm	TC Mbtu/h	SC Mbtu/h	S/T Ratio	Power kW	HR Mbtu/h	EER	HWC Mbtu/h	
20	4.0	1.6	3.8	Operation not recommended							Operation not recommended								
	6.0	3.3	7.6	Operation not recommended							Operation not recommended								
	8.0	4.8	11.1	700	16.6	1.58	11.2	92.0	3.08	2.2	Operation not recommended								
30	4.0	1.6	3.7	Operation not recommended							Operation not recommended								
				700	18.7	1.60	13.2	94.7	3.43	2.4	700	21.5	12.9	0.60	0.92	24.6	23.3	-	
	6.0	3.2	7.4	900	19.4	1.64	13.9	90.0	3.48	2.2	900	21.8	14.1	0.65	0.97	25.1	22.4	-	
				700	20.1	1.67	14.4	96.6	3.53	2.4	700	21.6	12.9	0.60	0.90	24.8	24.1	-	
	8.0	4.7	10.8	900	20.7	1.68	15.0	91.3	3.61	2.2	900	22.1	14.1	0.64	0.94	25.3	23.5	-	
				700	20.7	1.68	15.0	91.3	3.61	2.2	900	22.1	14.1	0.64	0.94	25.3	23.5	-	
40	4.0	1.5	3.6	Operation not recommended							Operation not recommended								
				700	21.8	1.65	16.2	98.9	3.87	2.6	700	23.9	15.4	0.65	1.02	27.4	23.6	-	
	6.0	3.1	7.1	900	22.6	1.68	16.8	93.2	3.93	2.4	900	24.4	16.9	0.69	1.06	28.0	22.9	-	
				700	23.0	1.69	17.2	100.4	3.98	2.7	700	24.1	15.4	0.64	0.98	27.5	24.5	-	
	8.0	4.5	10.4	900	23.8	1.73	17.9	94.5	4.04	2.5	900	24.7	16.9	0.68	1.03	28.2	23.9	-	
				700	24.1	1.71	18.3	101.9	4.14	2.8	700	25.8	17.2	0.67	1.14	29.7	22.7	1.4	
50	4.0	1.5	3.5	900	24.9	1.73	19.0	95.6	4.21	2.6	900	26.5	19.0	0.72	1.16	30.5	22.9	1.5	
				700	25.0	1.71	19.1	103.0	4.28	2.9	700	26.0	17.3	0.66	1.11	29.8	23.5	1.3	
	6.0	3.0	6.9	900	25.7	1.73	19.8	96.5	4.35	2.7	900	26.8	19.1	0.71	1.13	30.6	23.7	1.4	
				700	26.1	1.75	20.2	104.6	4.38	3.0	700	26.5	17.7	0.67	1.10	30.2	24.1	1.2	
	8.0	4.4	10.1	900	26.9	1.77	20.9	97.7	4.45	2.8	900	27.2	19.6	0.72	1.12	31.0	24.3	1.4	
				700	27.3	1.77	21.3	106.2	4.52	3.2	700	25.9	17.8	0.69	1.26	30.2	20.6	1.7	
60	4.0	1.4	3.3	900	28.0	1.79	21.9	98.8	4.60	3.0	900	26.6	19.7	0.74	1.28	31.0	20.7	1.8	
				700	28.4	1.77	22.4	107.6	4.71	3.3	700	26.1	17.9	0.69	1.23	30.3	21.3	1.6	
	6.0	2.9	6.7	900	29.1	1.78	23.0	100.0	4.79	3.0	900	26.9	19.8	0.74	1.25	31.1	21.5	1.7	
				700	29.4	1.81	23.3	108.9	4.76	3.4	700	26.6	18.4	0.69	1.22	30.7	21.8	1.5	
	8.0	4.2	9.8	900	30.1	1.82	23.9	101.0	4.85	3.1	900	27.3	20.4	0.75	1.24	31.5	22.0	1.6	
				700	30.6	1.84	24.3	110.4	4.87	3.6	700	26.0	18.5	0.71	1.38	30.7	18.8	2.1	
70	4.0	1.4	3.2	900	31.2	1.83	25.0	102.1	5.00	3.3	900	26.7	20.5	0.77	1.41	31.5	19.0	2.2	
				700	31.9	1.83	25.6	112.2	5.10	3.7	700	26.2	18.6	0.71	1.35	30.8	19.5	2.0	
	6.0	2.8	6.5	900	32.5	1.83	26.2	103.4	5.20	3.4	900	27.0	20.6	0.76	1.37	31.6	19.6	2.1	
				700	32.7	1.87	26.3	113.3	5.12	3.8	700	26.7	19.1	0.72	1.33	31.2	20.0	1.8	
	8.0	4.1	9.5	900	33.3	1.87	26.9	104.3	5.22	3.5	900	27.4	21.1	0.77	1.36	32.0	20.1	2.0	
				700	33.7	1.92	27.2	114.6	5.15	4.0	700	24.1	18.0	0.75	1.54	29.4	15.6	2.6	
80	4.0	1.4	3.1	900	34.2	1.91	27.7	105.2	5.25	3.7	900	24.8	19.9	0.80	1.57	30.1	15.7	2.8	
				700	35.3	1.91	28.8	116.7	5.43	4.1	700	24.3	18.1	0.74	1.50	29.4	16.2	2.5	
	6.0	2.7	6.3	900	35.7	1.89	29.3	106.8	5.53	3.8	900	25.0	20.0	0.80	1.53	30.2	16.3	2.7	
				700	35.8	1.95	29.2	117.4	5.39	4.3	700	24.7	18.5	0.75	1.49	29.8	16.6	2.3	
	8.0	4.0	9.2	900	36.2	1.93	29.6	107.2	5.50	3.9	900	25.4	20.5	0.81	1.52	30.6	16.7	2.5	
				700	36.9	2.00	30.0	118.7	5.40	4.5	700	22.2	17.4	0.79	1.71	28.0	13.0	3.3	
90	4.0	1.3	3.0	900	37.2	1.98	30.4	108.2	5.51	4.2	900	22.8	19.3	0.85	1.74	28.8	13.1	3.5	
				700	38.8	1.98	31.8	121.3	5.73	4.6	700	22.4	17.5	0.78	1.66	28.1	13.5	3.1	
	6.0	2.6	6.0	900	39.0	1.95	32.0	110.1	5.85	4.3	900	23.0	19.4	0.84	1.69	28.8	13.6	3.3	
				700	38.9	2.02	32.0	121.5	5.64	4.8	700	23.3	17.5	0.75	1.65	28.3	14.1	2.8	
	8.0	3.8	8.8	900	39.1	1.99	32.3	110.2	5.76	4.4	900	23.4	19.9	0.85	1.68	29.1	13.9	3.2	
				Operation not recommended							Operation not recommended								
100	4.0	1.3	2.9	Operation not recommended							Operation not recommended								
	6.0	2.5	5.8	Operation not recommended							700	21.1	17.0	0.80	1.87	27.5	11.3	3.8	
	8.0	3.7	8.5	Operation not recommended							900	21.7	18.8	0.87	1.91	28.2	11.4	4.1	
110	4.0	1.2	2.8	Operation not recommended							Operation not recommended								
				700	19.8	16.4	0.83	2.08	27.2	9.5	4.6	900	20.4	18.1	0.89	2.12	27.6	9.6	5.0
	6.0	2.4	5.6	700	20.1	16.8	0.83	2.06	27.4	9.8	4.3	700	20.1	16.8	0.83	2.06	27.4	9.8	4.3
				900	20.7	18.6	0.90	2.10	27.9	9.9	4.7	900	20.7	18.6	0.90	2.10	27.9	9.9	4.7
	8.0	3.5	8.2	Operation not recommended							Operation not recommended								
				700	18.9	16.6	0.88	2.35	27.0	8.0	5.5	900	19.3	18.0	0.93	2.42	27.5	8.0	6.0
120	4.0	1.2	2.7	Operation not recommended							Operation not recommended								
	6.0	2.3	5.4	Operation not recommended							700	19.1	16.6	0.87	2.28	26.9	8.4	5.1	
	8.0	3.4	7.9	Operation not recommended							900	19.5	18.0	0.92	2.35	27.5	8.3	5.7	

Multiple Flow Rates (for EWT) are shown in the table above. The lowest flow rate shown is used for geothermal open loop/well water systems with a minimum 50° F. The second flow rate shown is the minimum geothermal closed loop flow rate. The third flow rate shown is optimum for geothermal closed loop and the suggested flow rate for boiler tower applications.

036 - Performance Data

036 - Single Speed

EWT °F	Flow gpm	WPD		HEATING - EAT 70°F						COOLING - EAT 80/67 °F									
		PSI	FT	Airflow cfm	HC Mbtu/h	Power kW	HE Mbtu/h	LAT °F	COP	HWC Mbtu/h	Airflow cfm	TC Mbtu/h	SC Mbtu/h	S/T Ratio	Power kW	HR Mbtu/h	EER	HWC Mbtu/h	
20	5.0	1.6	3.8	Operation not recommended						Operation not recommended									
	7.0	2.9	6.8	Operation not recommended						Operation not recommended									
	9.0	4.3	9.9	1000	20.1	1.84	13.8	88.6	3.20	2.7	1200	20.6	1.88	14.2	85.9	3.21	2.4		
30	5.0	1.6	3.7	Operation not recommended						Operation not recommended									
	7.0	2.8	6.6	1000	22.4	1.86	16.0	90.7	3.52	2.9	1000	27.7	16.2	0.59	1.09	31.4	25.4	-	
				1200	23.3	1.91	16.8	88.0	3.57	2.6	1200	28.1	17.7	0.63	1.15	32.0	24.5	-	
	9.0	4.2	9.6	1000	24.2	1.92	17.6	92.4	3.69	3.0	1000	27.8	16.2	0.58	1.06	31.6	26.3	-	
1200				24.8	1.96	18.1	89.1	3.71	2.7	1200	28.5	17.7	0.62	1.11	32.3	25.7	-		
40	5.0	1.5	3.6	Operation not recommended						Operation not recommended									
	7.0	2.8	6.4	1000	26.3	1.93	19.7	94.4	4.00	3.2	1000	30.6	19.1	0.62	1.20	34.7	25.4	-	
				1200	27.2	1.97	20.5	91.0	4.06	3.0	1200	31.1	20.8	0.67	1.26	35.4	24.7	-	
	9.0	4.0	9.3	1000	27.7	1.98	21.0	95.7	4.11	3.3	1000	30.8	19.1	0.62	1.17	34.8	26.4	-	
1200				28.7	2.02	21.8	92.1	4.17	3.0	1200	31.5	20.8	0.66	1.22	35.7	25.8	-		
50	5.0	1.5	3.5	1000	29.2	2.00	22.4	97.0	4.29	3.5	1000	32.7	20.9	0.64	1.35	37.3	24.2	1.7	
				1200	30.1	2.03	23.2	93.2	4.36	3.2	1200	33.6	23.2	0.69	1.38	38.3	24.4	1.8	
	7.0	2.7	6.2	1000	30.2	2.00	23.4	98.0	4.43	3.6	1000	33.0	21.1	0.64	1.32	37.5	25.1	1.6	
				1200	31.2	2.02	24.3	94.0	4.51	3.3	1200	33.9	23.3	0.69	1.34	38.5	25.3	1.7	
9.0	3.9	9.1	1000	31.7	2.05	24.7	99.3	4.54	3.7	1000	33.6	21.6	0.64	1.30	38.0	25.7	1.4		
			1200	32.6	2.07	25.5	95.2	4.62	3.4	1200	34.5	23.9	0.69	1.33	39.0	25.9	1.6		
60	5.0	1.4	3.3	1000	32.9	2.06	25.9	100.5	4.68	3.9	1000	32.5	22.2	0.68	1.51	37.7	21.5	2.0	
				1200	33.7	2.08	26.6	96.0	4.76	3.6	1200	33.4	24.5	0.73	1.54	38.7	21.7	2.1	
	7.0	2.6	6.0	1000	34.2	2.06	27.2	101.7	4.87	4.0	1000	32.8	22.3	0.68	1.47	37.9	22.3	1.9	
				1200	35.0	2.07	27.9	97.0	4.96	3.7	1200	33.7	24.7	0.73	1.50	38.9	22.4	2.0	
9.0	3.8	8.8	1000	35.4	2.10	28.2	102.8	4.93	4.2	1000	33.4	22.9	0.68	1.46	38.4	22.8	1.7		
			1200	36.2	2.12	29.0	97.9	5.02	3.8	1200	34.3	25.3	0.74	1.49	39.4	23.0	1.9		
70	5.0	1.4	3.2	1000	36.5	2.13	29.3	103.8	5.03	4.4	1000	32.3	23.4	0.72	1.68	38.1	19.3	2.5	
				1200	37.5	2.13	30.2	98.9	5.16	4.1	1200	33.2	25.9	0.78	1.71	39.1	19.5	2.6	
	7.0	2.5	5.8	1000	38.1	2.12	30.9	105.3	5.28	4.5	1000	32.6	23.5	0.72	1.63	38.2	20.0	2.3	
				1200	38.8	2.12	31.6	100.0	5.38	4.2	1200	33.5	26.0	0.78	1.66	39.2	20.2	2.5	
9.0	3.7	8.5	1000	39.1	2.16	31.7	106.2	5.30	4.7	1000	33.2	24.1	0.73	1.62	38.7	20.5	2.2		
			1200	39.8	2.16	32.4	100.7	5.40	4.3	1200	34.1	26.7	0.78	1.65	39.7	20.7	2.4		
80	5.0	1.4	3.1	1000	39.9	2.19	32.4	106.9	5.33	4.9	1000	30.5	22.9	0.75	1.86	36.8	16.4	3.1	
				1200	40.4	2.18	33.0	101.2	5.43	4.6	1200	31.3	25.4	0.81	1.90	37.8	16.5	3.3	
	7.0	2.4	5.6	1000	41.8	2.18	34.4	108.7	5.62	5.1	1000	30.7	23.1	0.75	1.81	36.9	17.0	2.9	
				1200	42.3	2.16	34.9	102.7	5.73	4.7	1200	31.6	25.5	0.81	1.85	37.9	17.1	3.1	
9.0	3.5	8.2	1000	42.4	2.22	34.8	109.3	5.59	5.2	1000	31.2	23.7	0.76	1.80	37.4	17.4	2.7		
			1200	42.9	2.21	35.3	103.1	5.70	4.8	1200	32.1	26.2	0.82	1.83	38.3	17.5	3.0		
90	5.0	1.3	3.0	1000	43.3	2.26	35.5	110.1	5.61	5.5	1000	28.6	22.5	0.79	2.04	35.5	14.0	3.9	
				1200	43.6	2.23	36.0	103.7	5.72	5.1	1200	29.3	24.9	0.85	2.08	36.4	14.1	4.1	
	7.0	2.3	5.4	1000	45.5	2.24	37.8	112.1	5.95	5.7	1000	28.8	22.6	0.79	1.99	35.6	14.5	3.6	
				1200	45.8	2.21	38.2	105.3	6.07	5.3	1200	29.6	25.1	0.85	2.03	36.5	14.6	3.9	
9.0	3.4	7.9	1000	45.7	2.29	37.9	112.3	5.86	5.9	1000	29.5	23.3	0.79	1.93	36.1	15.3	3.4		
			1200	45.9	2.25	38.2	105.4	5.98	5.4	1200	30.1	25.7	0.85	2.01	37.0	15.0	3.7		
100	5.0	1.3	2.9	Operation not recommended						Operation not recommended									
	7.0	2.2	5.2	1000	27.2	2.18	0.80	2.22	34.7	12.3	4.5	1200	27.9	24.2	0.87	2.26	35.7	12.4	4.8
				1000	27.6	22.4	0.81	2.20	35.1	12.6	4.1	1200	28.4	24.8	0.87	2.24	36.0	12.7	4.6
110	5.0	1.2	2.8	Operation not recommended						Operation not recommended									
	7.0	2.2	5.0	1000	25.6	2.11	0.82	2.44	33.9	10.5	5.4	1200	26.3	23.3	0.89	2.49	34.8	10.5	5.9
				1000	26.0	21.6	0.83	2.42	34.2	10.7	5.0	1200	26.7	23.9	0.90	2.47	35.1	10.8	5.6
	9.0	3.2	7.3	1000	26.0	21.6	0.83	2.42	34.2	10.7	5.0	1200	26.7	23.9	0.90	2.47	35.1	10.8	5.6
1000				26.0	21.6	0.83	2.42	34.2	10.7	5.0	1200	26.7	23.9	0.90	2.47	35.1	10.8	5.6	
120	5.0	1.2	2.7	Operation not recommended						Operation not recommended									
	7.0	2.1	4.8	1000	24.2	2.1	0.09	2.76	33.6	8.8	6.5	1200	24.6	2.3	0.09	2.83	34.3	8.7	7.1
				1000	24.4	2.1	0.09	2.67	33.5	9.1	6.1	1200	24.9	2.3	0.09	2.75	34.3	9.1	6.7
	9.0	3.0	7.0	1000	24.4	2.1	0.09	2.67	33.5	9.1	6.1	1200	24.9	2.3	0.09	2.75	34.3	9.1	6.7
1000				24.4	2.1	0.09	2.67	33.5	9.1	6.1	1200	24.9	2.3	0.09	2.75	34.3	9.1	6.7	

3/7/17

Multiple Flow Rates (for EWT) are shown in the table above. The lowest flow rate shown is used for geothermal open loop/well water systems with a minimum 50° F. The second flow rate shown is the minimum geothermal closed loop flow rate. The third flow rate shown is optimum for geothermal closed loop and the suggested flow rate for boiler tower applications.

042 - Performance Data

042 - Single Speed

EWT °F	Flow gpm	WPD		HEATING - EAT 70°F							COOLING - EAT 80/67 °F												
		PSI	FT	Airflow cfm	HC Mbtu/h	Power kW	HE Mbtu/h	LAT °F	COP	HWC Mbtu/h	Airflow cfm	TC Mbtu/h	SC Mbtu/h	S/T Ratio	Power kW	HR Mbtu/h	EER	HWC Mbtu/h					
20	5.0	1.5	3.5	Operation not recommended							Operation not recommended												
	8.0	3.6	8.4	Operation not recommended							Operation not recommended												
	11.0	5.7	13.2	1100	25.2	2.45	16.9	91.2	3.02	4.1	1400	25.9	2.48	17.4	87.1	3.06	3.7	Operation not recommended					
30	5.0	1.5	3.4	Operation not recommended							Operation not recommended												
	8.0	3.5	8.1	1100	27.3	2.40	19.1	93.0	3.33	4.3	1100	34.1	22.6	0.66	1.60	39.6	21.3	-					
				1400	28.5	2.47	20.0	88.8	3.38	3.9	1400	34.6	24.7	0.71	1.69	40.4	20.5	-					
	11.0	5.6	12.8	1100	29.5	2.50	21.0	94.8	3.46	4.4	1100	34.3	22.6	0.66	1.55	39.8	22.1	-					
1400				30.3	2.53	21.7	90.0	3.51	4.0	1400	35.1	24.7	0.70	1.63	40.7	21.5	-						
40	5.0	1.4	3.3	Operation not recommended							Operation not recommended												
	8.0	3.4	7.9	1100	31.7	2.46	23.3	96.7	3.78	4.7	1100	38.5	25.7	0.67	1.73	44.4	22.2	-					
				1400	32.8	2.51	24.3	91.7	3.83	4.3	1400	39.2	28.1	0.72	1.82	45.4	21.6	-					
	11.0	5.4	12.5	1100	33.5	2.52	24.8	98.2	3.89	4.9	1100	38.8	25.7	0.66	1.68	44.5	23.0	-					
1400				34.6	2.57	25.8	92.9	3.95	4.4	1400	39.7	28.1	0.71	1.76	45.7	22.5	-						
50	5.0	1.4	3.2	1100	34.9	2.52	26.3	99.3	4.06	5.1	1100	41.9	27.5	0.66	1.92	48.5	21.8	2.5					
				1400	36.0	2.55	27.2	93.8	4.13	4.7	1400	43.1	30.4	0.71	1.96	49.8	22.0	2.6					
	8.0	3.3	7.7	1100	36.1	2.52	27.5	100.4	4.20	5.3	1100	42.3	27.7	0.65	1.87	48.7	22.6	2.3					
				1400	37.2	2.55	28.5	94.6	4.27	4.8	1400	43.5	30.6	0.70	1.91	50.0	22.8	2.5					
	11.0	5.2	12.1	1100	37.8	2.58	29.0	101.8	4.29	5.4	1100	43.0	28.4	0.66	1.85	49.3	23.2	2.1					
				1400	38.9	2.61	30.0	95.7	4.37	5.0	1400	44.2	31.4	0.71	1.89	50.6	23.4	2.4					
60	5.0	1.3	3.1	1100	39.3	2.61	30.4	103.0	4.41	5.7	1100	40.6	27.4	0.68	2.09	47.7	19.4	3.0					
				1400	40.2	2.63	31.3	96.6	4.49	5.3	1400	41.7	30.3	0.73	2.13	49.0	19.6	3.2					
	8.0	3.2	7.4	1100	40.8	2.60	31.9	104.4	4.60	5.9	1100	41.0	27.6	0.67	2.04	47.9	20.1	2.8					
				1400	41.8	2.62	32.9	97.6	4.68	5.4	1400	42.1	30.5	0.72	2.08	49.2	20.3	3.0					
	11.0	5.1	11.7	1100	42.3	2.66	33.2	105.6	4.65	6.1	1100	41.6	28.3	0.68	2.02	48.5	20.6	2.6					
				1400	43.2	2.68	34.1	98.6	4.73	5.6	1400	42.8	31.3	0.73	2.06	49.8	20.8	2.9					
70	5.0	1.3	3.0	1100	43.6	2.70	34.4	106.7	4.74	6.4	1100	39.3	27.3	0.70	2.27	47.0	17.3	3.8					
				1400	44.3	2.71	35.1	99.3	4.79	6.0	1400	40.4	30.2	0.75	2.31	48.2	17.5	4.0					
	8.0	3.1	7.2	1100	45.5	2.69	36.3	108.3	4.96	6.6	1100	39.6	27.5	0.69	2.21	47.2	18.0	3.5					
				1400	46.3	2.69	37.2	100.7	5.06	6.1	1400	40.7	30.4	0.75	2.25	48.4	18.1	3.8					
	11.0	4.9	11.3	1100	46.7	2.75	37.3	109.3	4.98	6.8	1100	40.3	28.2	0.70	2.19	47.7	18.4	3.3					
				1400	47.5	2.74	38.2	101.4	5.08	6.3	1400	41.4	31.2	0.75	2.23	49.0	18.6	3.6					
80	5.0	1.2	2.9	1100	48.0	2.79	38.4	110.4	5.03	7.2	1100	37.7	26.7	0.71	2.50	46.2	15.1	4.8					
				1400	48.6	2.78	39.1	102.2	5.13	6.7	1400	38.8	29.5	0.76	2.55	47.4	15.2	5.1					
	8.0	3.0	6.9	1100	50.3	2.78	40.8	112.3	5.30	7.5	1100	38.1	26.8	0.71	2.43	46.4	15.6	4.5					
				1400	50.9	2.76	41.5	103.6	5.41	6.9	1400	39.1	29.7	0.76	2.48	47.6	15.8	4.8					
	11.0	4.7	10.9	1100	51.0	2.84	41.3	112.9	5.27	7.7	1100	38.7	27.5	0.71	2.41	46.9	16.0	4.1					
				1400	51.5	2.81	41.9	104.1	5.37	7.1	1400	39.8	30.5	0.77	2.46	48.1	16.2	4.6					
90	5.0	1.2	2.8	1100	52.3	2.89	42.4	114.0	5.30	8.1	1100	36.1	26.0	0.72	2.73	45.5	13.2	6.0					
				1400	52.7	2.86	43.0	104.9	5.41	7.5	1400	37.1	28.8	0.78	2.79	46.7	13.3	6.4					
	8.0	2.9	6.7	1100	55.0	2.87	45.2	116.3	5.62	8.4	1100	36.5	26.2	0.72	2.66	45.6	13.7	5.6					
				1400	55.4	2.83	45.7	106.6	5.74	7.8	1400	37.5	29.0	0.77	2.71	46.7	13.8	6.1					
	11.0	4.6	10.5	1100	55.2	2.93	45.4	116.5	5.53	8.6	1100	37.3	26.5	0.71	2.51	45.9	14.9	5.2					
				1400	55.5	2.88	45.7	106.7	5.65	8.0	1400	38.1	29.7	0.78	2.69	47.3	14.2	5.8					
100	5.0	1.2	2.7	Operation not recommended							Operation not recommended												
	8.0	2.8	6.4	1100	34.7	25.5	0.74	2.95	44.8	11.7	6.9	1100	34.7	25.5	0.74	2.95	44.8	11.7	6.9				
				1400	35.7	28.3	0.79	3.01	45.9	11.8	7.5	1400	35.7	28.3	0.79	3.01	45.9	11.8	7.5				
	11.0	4.4	10.1	1100	35.3	26.2	0.74	2.93	45.3	12.0	6.4	1100	35.3	26.2	0.74	2.93	45.3	12.0	6.4				
1400				36.3	29.0	0.80	2.99	46.4	12.1	7.2	1400	36.3	29.0	0.80	2.99	46.4	12.1	7.2					
110	5.0	1.1	2.6	Operation not recommended							Operation not recommended												
	8.0	2.7	6.2	Operation not recommended							1100	32.9	24.9	0.76	3.25	44.2	10.1	8.5					
				1400	33.8	27.6	0.82	3.31	45.1	10.2	9.2	1400	33.8	27.6	0.82	3.31	45.1	10.2	9.2				
	11.0	4.2	9.8	Operation not recommended							1100	33.5	25.6	0.76	3.22	44.4	10.4	7.9					
1400				34.4	28.3	0.82	3.28	45.6	10.5	8.8	1400	34.4	28.3	0.82	3.28	45.6	10.5	8.8					
120	5.0	1.1	2.5	Operation not recommended							Operation not recommended												
	8.0	2.6	5.9	Operation not recommended							1100	31.3	25.1	0.80	3.65	43.7	8.6	10.3					
				1400	31.8	27.2	0.85	3.74	44.6	8.5	11.1	1400	31.8	27.2	0.85	3.74	44.6	8.5	11.1				
	11.0	4.1	9.4	Operation not recommended							1100	31.5	25.1	0.79	3.53	44.0	8.9	9.5					
1400				32.2	27.2	0.84	3.64	44.6	8.8	10.6	1400	32.2	27.2	0.84	3.64	44.6	8.8	10.6					

Multiple Flow Rates (for EWT) are shown in the table above. The lowest flow rate shown is used for geothermal open loop/well water systems with a minimum 50° F. The second flow rate shown is the minimum geothermal closed loop flow rate. The third flow rate shown is optimum for geothermal closed loop and the suggested flow rate for boiler tower applications. 3/7/17

048 - Performance Data

048 - Single Speed

EWT °F	Flow gpm	WPD		HEATING - EAT 70°F							COOLING - EAT 80/67 °F							
		PSI	FT	Airflow cfm	HC Mbtu/h	Power kW	HE Mbtu/h	LAT °F	COP	HWC Mbtu/h	Airflow cfm	TC Mbtu/h	SC Mbtu/h	S/T Ratio	Power kW	HR Mbtu/h	EER	HWC Mbtu/h
20	6.0	1.3	3.0	Operation not recommended							Operation not recommended							
	9.0	2.8	6.5	Operation not recommended							Operation not recommended							
	12.0	4.3	9.8	1300	29.5	2.78	20.0	91.0	3.11	5.3	Operation not recommended							
30	6.0	1.3	2.9	Operation not recommended							Operation not recommended							
				1300	34.3	2.72	25.0	94.4	3.69	5.6	1300	42.1	27.4	0.65	1.74	48.0	24.2	-
	9.0	2.7	6.3	1500	35.2	2.89	25.4	91.7	3.57	5.2	1500	42.7	29.9	0.70	1.83	49.0	23.3	-
				1300	35.2	2.90	25.3	95.1	3.56	5.8	1300	42.3	27.4	0.65	1.69	48.2	25.1	-
	12.0	4.1	9.6	1500	35.6	2.92	25.6	92.0	3.57	5.3	1500	43.3	29.9	0.69	1.77	49.3	24.5	-
40	6.0	1.2	2.9	Operation not recommended							Operation not recommended							
				1300	39.3	2.86	29.5	98.0	4.03	6.2	1300	45.7	30.2	0.66	1.91	52.2	23.9	-
	9.0	2.6	6.1	1500	40.2	2.98	30.0	94.8	3.95	5.7	1500	46.5	33.0	0.71	2.00	53.3	23.3	-
				1300	39.9	2.91	30.0	98.4	4.02	6.4	1300	46.0	30.2	0.66	1.85	52.3	24.9	-
	12.0	4.0	9.3	1500	40.8	3.01	30.5	95.2	3.97	5.8	1500	47.1	33.0	0.70	1.94	53.7	24.3	-
50	6.0	1.2	2.8	1300	41.9	2.94	31.9	99.8	4.18	6.7	1300	48.8	32.5	0.67	2.05	55.8	23.8	2.9
				1500	42.8	3.03	32.4	96.4	4.14	6.2	1500	49.8	35.3	0.71	2.18	57.3	22.8	3.1
	9.0	2.6	5.9	1300	44.3	2.99	34.1	101.6	4.34	6.9	1300	49.3	32.8	0.67	2.01	56.2	24.5	2.7
				1500	45.2	3.07	34.7	97.9	4.32	6.4	1500	50.3	35.7	0.71	2.13	57.6	23.6	2.9
	12.0	3.9	9.0	1300	45.0	3.03	34.7	102.1	4.36	7.2	1300	49.8	33.2	0.67	1.98	56.5	25.2	2.5
60	6.0	1.2	2.7	1500	46.0	3.10	35.4	98.4	4.35	6.5	1500	50.8	36.0	0.71	2.10	58.0	24.2	2.8
				1300	46.5	3.05	36.1	103.1	4.47	7.6	1300	47.4	32.3	0.68	2.26	55.1	21.0	3.5
	9.0	2.5	5.7	1500	47.5	3.10	36.9	99.3	4.49	7.0	1500	48.6	35.1	0.72	2.40	56.8	20.2	3.7
				1300	48.6	3.10	38.1	104.6	4.60	7.8	1300	47.9	32.6	0.68	2.21	55.4	21.6	3.3
	12.0	3.8	8.7	1500	49.7	3.14	39.0	100.7	4.64	7.2	1500	49.1	35.5	0.72	2.35	57.2	20.9	3.6
70	6.0	1.1	2.6	1300	49.7	3.13	39.0	105.4	4.64	8.0	1300	48.4	33.0	0.68	2.18	55.8	22.2	3.0
				1500	50.8	3.17	40.0	101.4	4.70	7.4	1500	49.6	35.8	0.72	2.32	57.5	21.4	3.4
	9.0	2.4	5.5	1300	51.1	3.16	40.3	106.4	4.74	8.5	1300	46.0	32.1	0.70	2.47	54.4	18.6	4.4
				1500	52.4	3.21	41.4	102.3	4.78	7.9	1500	47.4	34.9	0.74	2.63	56.4	18.1	4.7
	12.0	3.6	8.4	1300	53.0	3.20	42.1	107.7	4.85	8.8	1300	46.4	32.4	0.70	2.42	54.7	19.2	4.1
80	6.0	1.1	2.5	1500	54.2	3.21	43.2	103.4	4.95	8.1	1500	47.9	35.2	0.73	2.57	56.7	18.6	4.5
				1300	54.3	3.24	43.3	108.7	4.91	9.0	1300	46.9	32.7	0.70	2.38	55.0	19.7	3.8
	9.0	2.3	5.4	1500	55.6	3.24	44.5	104.3	5.03	8.3	1500	48.4	35.6	0.74	2.53	57.0	19.1	4.2
				1300	55.5	3.30	44.3	109.6	4.93	9.6	1300	43.2	31.1	0.72	2.74	52.6	15.8	5.6
	12.0	3.5	8.1	1500	56.8	3.28	45.6	105.1	5.08	8.8	1500	44.8	33.8	0.75	2.92	54.8	15.3	5.9
90	6.0	1.0	2.4	1300	56.9	3.34	45.5	110.5	4.99	9.8	1300	43.7	31.4	0.72	2.69	52.9	16.2	5.2
				1500	58.2	3.31	46.9	105.9	5.16	9.1	1500	45.3	34.1	0.75	2.86	55.1	15.8	5.6
	9.0	2.2	5.2	1300	58.6	3.38	47.0	111.7	5.08	10.1	1300	44.1	31.7	0.72	2.64	53.1	16.7	4.8
				1500	60.1	3.34	48.7	107.1	5.27	9.4	1500	45.8	34.5	0.75	2.82	55.4	16.3	5.4
	12.0	3.4	7.8	1300	60.0	3.44	48.2	112.7	5.11	10.7	1300	40.5	30.1	0.74	3.02	50.8	13.4	7.0
100	6.0	0.9	2.1	1500	61.4	3.39	49.8	107.9	5.31	9.9	1500	42.2	32.7	0.77	3.22	53.2	13.1	7.4
				1300	60.8	3.48	48.9	113.3	5.12	11.1	1300	40.9	30.3	0.74	2.96	51.0	13.8	6.5
	9.0	2.0	4.6	1500	62.3	3.40	50.7	108.4	5.36	10.2	1500	42.6	33.0	0.77	3.15	53.4	13.5	7.1
				1300	62.8	3.52	50.8	114.8	5.23	11.4	1300	41.2	30.5	0.74	3.02	51.5	13.6	6.1
	12.0	3.0	7.0	1500	64.5	3.44	52.8	109.8	5.50	10.6	1500	43.1	33.3	0.77	3.10	53.7	13.9	6.7
110	6.0	1.0	2.3	Operation not recommended							Operation not recommended							
				1300	37.0	29.3	0.79	3.31	48.3	11.2	8.1	Operation not recommended						
	9.0	2.2	5.0	1500	38.8	31.9	0.82	3.52	50.8	11.0	8.8	Operation not recommended						
				1300	37.4	29.7	0.79	3.25	48.4	11.5	7.5	Operation not recommended						
	12.0	3.3	7.6	1500	39.2	32.2	0.82	3.47	51.0	11.3	8.4	Operation not recommended						
120	6.0	1.0	2.2	Operation not recommended							Operation not recommended							
				1300	33.1	28.3	0.86	3.65	45.6	9.1	9.9	Operation not recommended						
	9.0	2.1	4.8	1500	34.9	30.7	0.88	3.89	48.2	9.0	10.8	Operation not recommended						
				1300	33.4	28.6	0.86	3.59	45.7	9.3	9.2	Operation not recommended						
	12.0	3.1	7.3	1500	35.2	31.1	0.88	3.83	48.3	9.2	10.2	Operation not recommended						
120	6.0	0.9	2.1	Operation not recommended							Operation not recommended							
				1300	34.6	27.6	0.80	4.27	49.2	8.1	12.0	Operation not recommended						
	9.0	2.0	4.6	1500	35.3	30.0	0.85	4.38	50.2	8.1	13.0	Operation not recommended						
				1300	35.0	27.6	0.79	4.13	49.0	8.5	11.1	Operation not recommended						
	12.0	3.0	7.0	1500	35.7	30.0	0.84	4.26	50.2	8.4	12.4	Operation not recommended						

Multiple Flow Rates (for EWT) are shown in the table above. The lowest flow rate shown is used for geothermal open loop/well water systems with a minimum 50° F. The second flow rate shown is the minimum geothermal closed loop flow rate. The third flow rate shown is optimum for geothermal closed loop and the suggested flow rate for boiler tower applications.

060 - Performance Data

060 - Single Speed

EWT °F	Flow gpm	WPD		HEATING - EAT 70°F							COOLING - EAT 80/67 °F								
		PSI	FT	Airflow cfm	HC Mbtu/h	Power kW	HE Mbtu/h	LAT °F	COP	HWC Mbtu/h	Airflow cfm	TC Mbtu/h	SC Mbtu/h	S/T Ratio	Power kW	HR Mbtu/h	EER	HWC Mbtu/h	
20	9.0	2.2	5.1	Operation not recommended							Operation not recommended								
	12.0	4.0	9.2	Operation not recommended							Operation not recommended								
	15.0	5.8	13.5	1500	40.5	3.88	27.2	95.0	3.05	6.5	Operation not recommended								
30	9.0	2.1	4.9	Operation not recommended							Operation not recommended								
	12.0	3.9	8.9	1500	45.5	3.76	32.6	98.1	3.54	6.8	1500	54.0	33.1	0.61	2.46	62.4	22.0	-	
	15.0	5.7	13.1	2000	46.7	4.00	33.0	91.6	3.42	6.2	2000	54.9	36.2	0.66	2.59	63.7	21.2	-	
40	9.0	2.1	4.8	Operation not recommended							Operation not recommended								
	12.0	3.7	8.7	1500	51.6	3.97	38.0	101.8	3.81	7.5	1500	58.1	36.9	0.64	2.71	67.4	21.5	-	
	15.0	5.5	12.7	2000	52.8	4.14	38.6	94.4	3.74	6.9	2000	59.2	40.3	0.68	2.84	68.9	20.8	-	
50	9.0	2.0	4.6	1500	54.5	4.09	40.6	103.7	3.91	8.1	1500	61.7	40.1	0.65	2.93	71.7	21.0	3.9	
	12.0	3.6	8.4	2000	55.7	4.22	41.3	95.8	3.87	7.5	2000	62.9	43.6	0.69	3.12	73.6	20.2	4.1	
	15.0	5.3	12.3	1500	57.7	4.17	43.5	105.6	4.05	8.4	1500	62.3	40.4	0.65	2.87	72.1	21.7	3.6	
60	9.0	1.9	4.5	1500	60.2	4.27	45.7	107.2	4.13	9.1	1500	59.9	39.9	0.67	3.21	70.8	18.6	4.7	
	12.0	3.5	8.1	2000	61.5	4.34	46.7	98.5	4.15	8.4	2000	61.4	43.4	0.71	3.42	73.1	18.0	5.0	
	15.0	5.1	11.9	1500	63.0	4.34	48.2	108.9	4.25	9.4	1500	60.5	40.3	0.67	3.15	71.2	19.2	4.4	
70	9.0	1.9	4.3	1500	65.9	4.44	50.7	110.7	4.35	10.3	1500	58.1	39.8	0.69	3.49	70.0	16.6	5.9	
	12.0	3.4	7.9	2000	68.9	4.53	53.4	101.9	4.46	9.5	2000	59.9	43.2	0.72	3.72	72.6	16.1	6.3	
	15.0	5.0	11.5	1500	70.1	4.56	54.5	113.2	4.50	10.9	1500	59.2	40.6	0.69	3.36	70.7	17.6	5.1	
80	9.0	1.8	4.2	1500	71.2	4.63	55.4	113.9	4.50	11.5	1500	54.9	38.4	0.70	3.85	68.0	14.2	7.5	
	12.0	3.3	7.6	2000	72.8	4.61	57.1	103.7	4.63	10.7	2000	56.9	41.7	0.73	4.11	70.9	13.9	8.0	
	15.0	4.8	11.1	1500	72.9	4.69	56.9	115.0	4.55	11.9	1500	55.5	38.7	0.70	3.78	68.4	14.7	7.0	
90	9.0	1.8	4.0	1500	74.4	4.75	58.9	116.3	4.63	12.2	1500	56.0	39.1	0.70	3.71	68.7	15.1	6.5	
	12.0	3.2	7.3	2000	76.4	4.82	60.0	117.2	4.65	13.0	2000	51.7	36.9	0.71	4.22	66.1	12.3	9.4	
	15.0	4.6	10.7	1500	78.3	4.75	62.1	106.2	4.83	12.0	2000	54.0	40.1	0.74	4.49	69.3	12.0	10.0	
100	9.0	1.7	3.9	1500	77.4	4.87	60.8	117.8	4.66	13.4	1500	52.3	37.2	0.71	4.14	66.4	12.6	8.8	
	12.0	3.1	7.1	2000	79.4	4.77	63.1	106.7	4.88	12.4	2000	54.5	40.5	0.74	4.40	69.5	12.4	9.5	
	15.0	4.5	10.3	1500	80.1	4.93	63.3	119.4	4.76	13.8	1500	54.4	37.3	0.69	4.03	68.2	13.5	8.2	
110	9.0	1.6	3.8	1500	82.2	4.82	65.8	108.1	5.00	12.8	2000	55.1	40.9	0.74	4.33	69.9	12.7	9.1	
	12.0	2.9	6.8	Operation not recommended							Operation not recommended								
	15.0	4.3	9.9	Operation not recommended							Operation not recommended								
120	9.0	1.6	3.6	Operation not recommended							Operation not recommended								
	12.0	2.8	6.5	Operation not recommended							Operation not recommended								
	15.0	4.1	9.6	1500	44.2	33.7	0.76	5.97	64.5	7.4	16.1	1500	44.6	33.7	0.76	5.78	64.3	7.7	15.0
				2000	45.5	36.6	0.80	5.96	65.8	7.6	16.7	2000	45.5	36.6	0.80	5.96	65.8	7.6	16.7

Multiple Flow Rates (for EWT) are shown in the table above. The lowest flow rate shown is used for geothermal open loop/well water systems with a minimum 50° F. The second flow rate shown is the minimum geothermal closed loop flow rate. The third flow rate shown is optimum for geothermal closed loop and the suggested flow rate for boiler tower applications.

070 - Performance Data

070 - Single Speed

EWT °F	Flow gpm	WPD		HEATING - EAT 70°F							COOLING - EAT 80/67 °F							
		PSI	FT	Airflow cfm	HC Mbtu/h	Power kW	HE Mbtu/h	LAT °F	COP	HWC Mbtu/h	Airflow cfm	TC Mbtu/h	SC Mbtu/h	S/T Ratio	Power kW	HR Mbtu/h	EER	HWC Mbtu/h
20	12.0	3.4	7.8	Operation not recommended							Operation not recommended							
	15.0	5.1	11.9	Operation not recommended							Operation not recommended							
	18.0	6.9	16.0	1700	44.5	4.44	29.4	94.3	2.94	7.7	Operation not recommended							
30	12.0	3.3	7.6	Operation not recommended							Operation not recommended							
	15.0	5.0	11.6	1700	51.9	4.41	36.8	98.3	3.45	8.1	1700	57.4	34.0	0.59	2.87	67.2	20.0	-
	18.0	6.7	15.6	2100	53.3	4.70	37.3	93.5	3.33	7.4	2100	58.3	37.2	0.64	3.02	68.6	19.3	-
40	12.0	3.2	7.4	Operation not recommended							Operation not recommended							
	15.0	4.8	11.2	1700	59.9	4.76	43.7	102.6	3.69	9.2	1700	63.0	38.7	0.61	3.05	73.4	20.7	-
	18.0	6.5	15.1	2100	61.3	4.93	44.5	97.0	3.64	8.4	2100	64.5	42.2	0.65	3.19	75.3	20.2	-
50	12.0	3.1	7.1	1700	62.5	4.85	46.0	104.1	3.78	9.7	1700	67.1	42.6	0.64	3.38	78.6	19.8	4.3
	15.0	4.7	10.9	2100	63.9	5.00	46.8	98.2	3.74	8.9	2100	68.4	46.3	0.68	3.60	80.7	19.0	4.5
	18.0	6.3	14.6	1700	66.2	4.94	49.3	106.0	3.92	10.0	1700	67.8	43.0	0.63	3.31	79.1	20.5	4.0
60	12.0	3.0	6.9	2100	67.5	5.07	50.2	99.8	3.90	9.2	2100	69.1	46.8	0.68	3.52	81.1	19.7	4.3
	15.0	4.5	10.5	1700	67.2	5.00	50.2	106.6	3.94	10.3	1700	68.4	43.5	0.64	3.26	79.5	21.0	3.7
	18.0	6.1	14.2	2100	68.7	5.12	51.2	100.3	3.93	9.4	2100	69.8	47.2	0.68	3.46	81.6	20.2	4.1
70	12.0	2.9	6.7	1700	69.6	5.10	52.2	107.9	4.00	10.8	1700	66.3	42.3	0.64	3.68	78.9	18.0	5.2
	15.0	4.4	10.2	2100	71.1	5.18	53.4	101.3	4.02	10.0	2100	68.0	46.0	0.68	3.92	81.4	17.3	5.5
	18.0	5.9	13.7	1700	72.8	5.18	55.1	109.6	4.11	11.2	1700	67.0	42.7	0.64	3.61	79.3	18.5	4.8
80	12.0	2.8	6.5	2100	74.3	5.25	56.4	102.8	4.15	10.3	2100	68.7	46.4	0.68	3.84	81.8	17.9	5.2
	15.0	4.3	9.8	1700	74.3	5.24	56.4	110.5	4.16	11.5	1700	67.6	43.1	0.64	3.55	79.7	19.0	4.5
	18.0	5.7	13.2	2100	76.0	5.30	57.9	103.5	4.20	10.6	2100	69.4	46.9	0.68	3.78	82.2	18.4	5.0
90	12.0	2.7	6.2	1700	76.6	5.34	58.3	111.7	4.20	12.2	1700	65.5	42.0	0.64	3.99	79.1	16.4	6.5
	15.0	4.1	9.5	2100	80.4	5.42	61.9	105.4	4.35	11.3	2100	67.5	45.6	0.68	4.25	82.0	15.9	6.9
	18.0	5.5	12.8	1700	79.4	5.42	60.9	113.2	4.29	12.6	1700	66.1	42.4	0.64	3.91	79.5	16.9	6.1
100	12.0	2.6	6.0	2100	81.2	5.43	62.6	105.8	4.38	11.6	2100	68.3	46.0	0.67	4.16	82.4	16.4	6.6
	15.0	4.0	9.1	1700	81.4	5.48	62.7	114.3	4.35	13.0	1700	66.8	42.8	0.64	3.84	79.9	17.4	5.6
	18.0	5.3	12.3	2100	83.3	5.48	64.6	106.7	4.46	11.9	2100	68.9	46.5	0.67	4.09	82.9	16.8	6.3
110	12.0	2.5	5.8	1700	82.3	5.57	63.3	114.8	4.33	13.7	1700	60.3	22.9	0.38	4.39	75.2	13.7	8.2
	15.0	3.8	8.8	2100	84.2	5.54	65.3	107.1	4.46	12.7	2100	62.5	24.9	0.40	4.67	78.5	13.4	8.7
	18.0	5.1	11.8	1700	84.3	5.64	65.0	115.9	4.38	14.1	1700	60.9	23.1	0.38	4.30	75.6	14.2	7.7
120	12.0	2.4	5.5	2100	86.3	5.58	67.2	108.0	4.53	13.1	2100	63.2	25.1	0.40	4.57	78.8	13.8	8.3
	15.0	3.7	8.4	1700	86.8	5.70	67.4	117.3	4.46	14.6	1700	61.5	23.4	0.38	4.23	75.9	14.6	7.1
	18.0	4.9	11.4	2100	89.0	5.64	69.8	109.2	4.63	13.5	2100	63.8	25.4	0.40	4.50	79.2	14.2	7.9
130	12.0	2.3	5.3	1700	88.0	5.79	68.3	118.0	4.46	15.4	1700	55.1	3.8	0.07	4.78	71.4	11.5	10.3
	15.0	3.5	8.1	2100	90.2	5.70	70.7	109.8	4.63	14.3	2100	57.5	4.2	0.07	5.10	74.9	11.3	10.9
	18.0	4.7	10.9	1700	89.2	5.85	69.2	118.6	4.47	15.9	1700	55.7	3.9	0.07	4.69	71.7	11.9	9.6
140	12.0	2.2	5.1	2100	91.4	5.73	71.9	110.3	4.68	14.7	2100	58.1	4.2	0.07	4.99	75.1	11.6	10.4
	15.0	3.3	7.8	1700	92.3	5.92	72.1	120.3	4.56	16.4	1700	58.3	40.1	0.69	4.66	74.2	12.5	8.9
	18.0	4.5	10.6	2100	94.7	5.79	74.9	111.8	4.79	15.2	2100	58.7	4.2	0.07	4.91	75.5	12.0	9.9
150	12.0	2.1	4.9	Operation not recommended							Operation not recommended							
	15.0	3.0	7.4	Operation not recommended							Operation not recommended							
	18.0	4.0	9.9	1700	52.8	20.2	0.38	5.19	70.5	10.2	12.0	2100	55.2	21.9	0.40	5.53	74.1	10.0
160	12.0	2.0	4.7	Operation not recommended							Operation not recommended							
	15.0	2.9	7.1	Operation not recommended							Operation not recommended							
	18.0	3.8	9.5	1700	53.3	20.4	0.38	5.10	70.7	10.4	11.1	2100	55.8	22.2	0.40	5.44	74.4	10.3
170	12.0	1.9	4.5	Operation not recommended							Operation not recommended							
	15.0	2.7	6.9	Operation not recommended							Operation not recommended							
	18.0	3.6	9.1	1700	49.8	36.5	0.73	5.69	69.2	8.7	14.6	2100	52.4	39.6	0.76	6.07	73.1	8.6
180	12.0	1.8	4.3	Operation not recommended							Operation not recommended							
	15.0	2.5	6.7	Operation not recommended							Operation not recommended							
	18.0	3.4	8.8	1700	50.2	36.9	0.73	5.59	69.4	9.0	13.6	2100	52.9	40.1	0.76	5.97	73.3	8.9
190	12.0	1.7	4.1	Operation not recommended							Operation not recommended							
	15.0	2.3	6.1	Operation not recommended							Operation not recommended							
	18.0	3.1	8.1	1700	47.5	35.2	0.74	6.59	70.0	7.2	17.7	2100	48.3	38.2	0.79	6.76	71.4	7.1
200	12.0	1.6	3.9	Operation not recommended							Operation not recommended							
	15.0	2.1	5.6	Operation not recommended							Operation not recommended							
	18.0	2.8	7.4	1700	47.9	35.2	0.73	6.38	69.6	7.5	16.4	2100	48.9	38.2	0.78	6.58	71.4	7.4

Multiple Flow Rates (for EWT) are shown in the table above. The lowest flow rate shown is used for geothermal open loop/well water systems with a minimum 50° F. The second flow rate shown is the minimum geothermal closed loop flow rate. The third flow rate shown is optimum for geothermal closed loop and the suggested flow rate for boiler tower applications.

026 - Performance Data

026 - Dual Capacity Low Speed

EWT °F	Flow gpm	WPD		HEATING - EAT 70°F							COOLING - EAT 80/67 °F										
		PSI	FT	Airflow cfm	HC Mbtu/h	Power kW	HE Mbtu/h	LAT °F	COP	HWC Mbtu/h	Airflow cfm	TC Mbtu/h	SC Mbtu/h	S/T Ratio	Power kW	HR Mbtu/h	EER	HWC Mbtu/h			
20	3.0	1.0	2.3	Operation not recommended							Operation not recommended										
	5.0	2.6	5.9	Operation not recommended							Operation not recommended										
	7.0	4.0	9.2	500	11.7	1.22	7.6	91.7	2.82	1.8	700	11.9	1.17	7.9	85.7	2.98	1.6				
30	3.0	1.0	2.3	Operation not recommended							Operation not recommended										
	5.0	2.5	5.8	500	12.5	1.12	8.7	93.2	3.28	1.8	500	17.2	10.2	0.60	0.63	19.3	27.4	-			
				700	13.1	1.15	9.1	87.3	3.32	1.6	700	17.5	11.2	0.64	0.66	19.7	26.4	-			
	7.0	3.9	8.9	500	13.7	1.23	9.5	95.4	3.26	1.8	500	17.3	10.2	0.59	0.61	19.4	28.3	-			
				700	13.9	1.18	9.9	88.4	3.45	1.6	700	17.7	11.2	0.63	0.64	19.9	27.7	-			
40	3.0	1.0	2.2	Operation not recommended							Operation not recommended										
	5.0	2.4	5.6	500	14.9	1.14	11.0	97.5	3.80	1.8	500	18.6	12.3	0.66	0.68	21.0	27.2	-			
				700	15.4	1.17	11.4	90.3	3.86	1.7	700	19.0	13.5	0.71	0.72	21.4	26.4	-			
	7.0	3.7	8.7	500	15.7	1.17	11.7	99.0	3.91	1.9	500	18.8	12.3	0.66	0.66	21.0	28.3	-			
				700	16.2	1.20	12.1	91.4	3.97	1.7	700	19.2	13.5	0.70	0.70	21.6	27.6	-			
50	3.0	0.9	2.1	500	16.6	1.17	12.6	100.7	4.16	1.9	500	19.6	13.8	0.70	0.76	22.2	25.8	0.7			
				700	17.1	1.18	13.1	92.6	4.23	1.7	700	20.2	15.2	0.75	0.78	22.8	26.0	0.8			
	5.0	2.3	5.4	500	17.2	1.17	13.2	101.8	4.31	1.9	500	19.8	13.8	0.70	0.74	22.3	26.7	0.7			
				700	17.7	1.18	13.6	93.4	4.38	1.8	700	20.4	15.3	0.75	0.76	22.9	26.9	0.7			
	7.0	3.6	8.4	500	18.0	1.20	13.9	103.3	4.40	2.0	500	20.1	14.2	0.70	0.74	22.7	27.4	0.6			
				700	18.5	1.21	14.4	94.5	4.48	1.8	700	20.7	15.7	0.76	0.75	23.3	27.6	0.7			
60	3.0	0.9	2.1	500	18.8	1.19	14.7	104.7	4.60	2.1	500	19.1	13.6	0.71	0.86	22.1	22.1	1.0			
				700	19.2	1.20	15.1	95.4	4.68	1.9	700	19.6	15.1	0.77	0.88	22.6	22.3	1.0			
	5.0	2.3	5.3	500	19.5	1.19	15.4	106.1	4.80	2.1	500	19.3	13.7	0.71	0.84	22.2	22.9	0.9			
				700	20.0	1.20	15.9	96.4	4.88	2.0	700	19.8	15.2	0.76	0.86	22.7	23.1	1.0			
	7.0	3.5	8.1	500	20.2	1.22	16.0	107.4	4.86	2.2	500	19.6	14.0	0.72	0.83	22.5	23.5	0.8			
				700	20.7	1.23	16.5	97.3	4.94	2.0	700	20.2	15.6	0.77	0.85	23.1	23.7	0.9			
70	3.0	0.9	2.0	500	20.9	1.22	16.8	108.8	5.02	2.3	500	18.6	13.5	0.73	0.97	21.9	19.3	1.3			
				700	21.3	1.22	17.2	98.2	5.12	2.1	700	19.1	14.9	0.78	0.98	22.5	19.4	1.4			
	5.0	2.2	5.1	500	21.8	1.22	17.7	110.5	5.26	2.4	500	18.8	13.6	0.72	0.94	22.0	20.0	1.3			
				700	22.2	1.22	18.1	99.4	5.37	2.2	700	19.3	15.0	0.78	0.96	22.6	20.1	1.4			
	7.0	3.4	7.9	500	22.4	1.24	18.2	111.5	5.29	2.4	500	19.1	13.9	0.73	0.93	22.3	20.5	1.2			
				700	22.8	1.24	18.6	100.2	5.39	2.2	700	19.6	15.4	0.79	0.95	22.8	20.6	1.3			
80	3.0	0.8	1.9	500	23.1	1.25	18.8	112.8	5.42	2.6	500	17.2	12.1	0.70	1.09	20.9	15.7	1.8			
				700	23.4	1.24	19.2	101.0	5.53	2.4	700	17.6	13.4	0.76	1.11	21.4	15.9	1.9			
	5.0	2.1	4.9	500	24.2	1.24	20.0	114.8	5.72	2.6	500	17.3	12.2	0.70	1.06	21.0	16.3	1.7			
				700	24.5	1.23	20.3	102.4	5.83	2.4	700	17.8	13.5	0.76	1.08	21.5	16.4	1.9			
	7.0	3.3	7.6	500	24.5	1.27	20.2	115.5	5.68	2.7	500	17.6	12.5	0.71	1.05	21.2	16.7	1.6			
				700	24.8	1.26	20.5	102.8	5.79	2.5	700	18.1	13.8	0.76	1.08	21.8	16.8	1.8			
90	3.0	0.8	1.9	500	25.3	1.28	20.9	116.8	5.80	2.9	500	15.7	10.7	0.68	1.22	19.9	12.9	2.4			
				700	25.5	1.26	21.2	103.7	5.92	2.7	700	16.2	11.8	0.73	1.24	20.4	13.0	2.6			
	5.0	2.0	4.7	500	26.6	1.27	22.2	119.2	6.15	3.0	500	15.9	10.7	0.68	1.19	20.1	13.4	2.3			
				700	26.7	1.25	22.5	105.4	6.28	2.8	700	16.3	11.9	0.73	1.21	20.5	13.5	2.5			
	7.0	3.2	7.3	500	26.7	1.29	22.3	119.4	6.06	3.1	500	16.2	11.0	0.68	1.18	20.2	13.7	2.1			
				700	26.8	1.27	22.5	105.4	6.18	2.8	700	16.6	12.2	0.73	1.20	20.7	13.8	2.4			
100	3.0	0.8	1.8	Operation not recommended							Operation not recommended										
	5.0	2.0	4.6	500	14.9	1.15	11.5	0.77	1.38	19.6	10.8	3.0									
				700	15.3	1.27	0.83	1.41	20.1	10.9	3.2										
	7.0	3.1	7.1	500	15.1	1.18	0.78	1.37	19.8	11.1	2.8										
700				15.6	1.31	0.84	1.40	20.3	11.1	3.1											
110	3.0	0.7	1.7	Operation not recommended							Operation not recommended										
	5.0	1.9	4.4	500	13.9	1.22	0.88	1.57	19.2	8.8	3.8										
				700	14.3	1.36	0.95	1.60	19.7	8.9	4.1										
	7.0	2.9	6.8	500	14.1	1.26	0.89	1.56	19.4	9.0	3.5										
700				14.5	1.39	0.96	1.59	19.9	9.1	3.9											
120	3.0	0.7	1.7	Operation not recommended							Operation not recommended										
	5.0	1.8	4.2	500	13.1	1.22	0.93	1.81	19.3	7.2	4.7										
				700	13.3	1.32	0.99	1.86	19.7	7.2	5.1										
	7.0	2.8	6.5	500	13.2	1.22	0.92	1.75	19.2	7.5	4.3										
700				13.5	1.32	0.98	1.81	19.7	7.5	4.8											

Multiple Flow Rates (for EWT) are shown in the table above. The lowest flow rate shown is used for geothermal open loop/well water systems with a minimum 50° F. The second flow rate shown is the minimum geothermal closed loop flow rate. The third flow rate shown is optimum for geothermal closed loop and the suggested flow rate for boiler tower applications.

3/7/17

026 - Performance Data

026 - Dual Capacity High Speed

EWT °F	Flow gpm	WPD		HEATING - EAT 70°F							COOLING - EAT 80/67 °F							
		PSI	FT	Airflow cfm	HC Mbtu/h	Power kW	HE Mbtu/h	LAT °F	COP	HWC Mbtu/h	Airflow cfm	TC Mbtu/h	SC Mbtu/h	S/T Ratio	Power kW	HR Mbtu/h	EER	HWC Mbtu/h
20	4.0	1.4	3.2	Operation not recommended							Operation not recommended							
	6.0	3.4	7.8	Operation not recommended							Operation not recommended							
	8.0	5.3	12.2	700	16.0	1.49	10.9	91.1	3.14	2.1	Operation not recommended							
30	4.0	1.4	3.2	Operation not recommended							Operation not recommended							
	6.0	3.3	7.6	700	18.2	1.50	13.1	94.1	3.56	2.3	700	23.0	14.0	0.61	1.00	26.4	23.0	-
	8.0	5.1	11.8	900	18.7	1.54	13.5	89.3	3.55	2.1	900	23.4	15.3	0.65	1.06	27.0	22.2	-
				700	18.6	1.55	13.3	94.6	3.52	2.3	700	23.1	14.0	0.61	0.97	26.5	23.8	-
40	4.0	1.3	3.1	Operation not recommended							Operation not recommended							
	6.0	3.2	7.4	700	20.9	1.57	15.5	97.6	3.90	2.5	700	25.0	16.4	0.66	1.10	28.8	22.6	-
				900	21.5	1.60	16.0	92.1	3.94	2.3	900	25.5	17.9	0.70	1.16	29.4	22.0	-
	8.0	5.0	11.5	700	21.3	1.58	15.9	98.1	3.94	2.6	700	25.2	16.4	0.65	1.07	28.8	23.5	-
				900	22.0	1.62	16.4	92.6	3.98	2.4	900	25.8	17.9	0.70	1.12	29.6	23.0	-
50	4.0	1.3	3.0	700	22.7	1.60	17.2	100.0	4.16	2.7	700	25.6	17.1	0.67	1.26	29.9	20.3	1.3
				900	23.4	1.62	17.8	94.0	4.23	2.5	900	26.9	19.0	0.71	1.33	31.5	20.3	1.4
	6.0	3.1	7.2	700	23.5	1.63	17.9	101.1	4.22	2.8	700	26.2	17.3	0.66	1.19	30.2	22.0	1.3
				900	24.3	1.66	18.6	95.0	4.30	2.6	900	27.5	19.2	0.70	1.25	31.8	22.0	1.4
	8.0	4.8	11.1	700	24.0	1.65	18.4	101.8	4.28	2.9	700	26.4	18.5	0.70	1.16	30.4	22.7	1.2
				900	24.8	1.67	19.1	95.5	4.35	2.7	900	27.8	20.5	0.74	1.22	32.0	22.8	1.3
60	4.0	1.2	2.9	700	25.0	1.67	19.3	103.0	4.39	3.1	700	25.0	17.2	0.69	1.38	29.7	18.1	1.6
				900	25.8	1.68	20.0	96.5	4.50	2.9	900	26.2	19.1	0.73	1.44	31.1	18.2	1.7
	6.0	3.0	6.9	700	26.1	1.71	20.2	104.5	4.46	3.2	700	25.6	17.4	0.68	1.31	30.0	19.5	1.5
				900	26.9	1.73	21.0	97.7	4.57	2.9	900	26.8	19.3	0.72	1.36	31.4	19.6	1.6
	8.0	4.7	10.8	700	26.7	1.73	20.8	105.3	4.52	3.3	700	25.8	18.3	0.71	1.28	30.2	20.2	1.4
				900	27.6	1.74	21.7	98.4	4.65	3.0	900	27.1	20.3	0.75	1.34	31.7	20.3	1.6
70	4.0	1.2	2.8	700	27.3	1.74	21.3	106.1	4.60	3.5	700	24.4	17.2	0.71	1.49	29.5	16.3	2.0
				900	28.6	1.81	22.4	99.4	4.63	3.2	900	25.5	19.2	0.75	1.55	30.7	16.4	2.1
	6.0	2.9	6.7	700	28.7	1.80	22.5	107.9	4.68	3.6	700	25.0	17.4	0.70	1.43	29.9	17.5	1.9
				900	29.6	1.80	23.5	100.5	4.83	3.3	900	26.1	19.3	0.74	1.48	31.1	17.6	2.0
	8.0	4.5	10.4	700	29.4	1.82	23.2	108.9	4.74	3.7	700	25.3	18.1	0.72	1.39	30.0	18.1	1.7
				900	30.4	1.81	24.2	101.3	4.92	3.4	900	26.4	20.1	0.76	1.45	31.3	18.2	1.9
80	4.0	1.2	2.7	700	29.5	1.81	23.3	109.0	4.77	3.9	700	22.8	17.1	0.75	1.65	28.4	13.8	2.5
				900	30.5	1.80	24.4	101.4	4.98	3.6	900	23.7	19.1	0.80	1.70	29.5	14.0	2.7
	6.0	2.8	6.5	700	31.2	1.88	24.8	111.3	4.85	4.0	700	23.4	17.4	0.74	1.59	28.9	14.7	2.3
				900	32.3	1.87	25.9	103.2	5.07	3.7	900	24.4	19.2	0.79	1.64	30.0	14.9	2.5
	8.0	4.3	10.0	700	32.1	1.91	25.6	112.5	4.93	4.1	700	23.7	17.8	0.75	1.56	29.0	15.2	2.2
				900	33.2	1.88	26.8	104.2	5.18	3.8	900	24.7	19.7	0.80	1.61	30.1	15.4	2.4
90	4.0	1.1	2.6	700	31.7	1.89	25.3	112.0	4.93	4.3	700	21.2	17.1	0.80	1.80	27.4	11.8	3.1
				900	32.9	1.86	26.5	103.8	5.19	4.0	900	22.0	18.9	0.86	1.85	28.3	11.9	3.3
	6.0	2.7	6.2	700	33.7	1.97	27.0	114.6	5.02	4.5	700	21.8	17.3	0.79	1.75	27.8	12.5	2.9
				900	34.9	1.94	28.3	105.9	5.29	4.1	900	22.6	19.2	0.85	1.80	28.8	12.6	3.2
	8.0	4.2	9.7	700	34.8	2.00	28.0	116.0	5.10	4.6	700	22.2	17.1	0.77	1.66	27.9	13.4	2.7
				900	36.0	1.95	29.3	107.0	5.41	4.3	900	22.9	19.3	0.84	1.76	28.9	13.0	3.0
100	4.0	1.1	2.5	Operation not recommended							Operation not recommended							
	6.0	2.6	6.0	700	20.8	16.9	0.81	1.96	27.5	10.6	3.6	Operation not recommended						
				900	21.5	18.8	0.87	1.99	28.3	10.8	3.9	Operation not recommended						
	8.0	4.0	9.3	700	21.1	16.9	0.80	1.93	27.7	10.9	3.3	Operation not recommended						
900				21.8	18.7	0.86	1.96	28.4	11.1	3.7	Operation not recommended							
110	4.0	1.0	2.4	Operation not recommended							Operation not recommended							
	6.0	2.5	5.8	700	19.9	16.5	0.83	2.18	27.3	9.1	4.4	Operation not recommended						
				900	20.4	18.4	0.90	2.19	27.9	9.3	4.7	Operation not recommended						
	8.0	3.9	9.0	700	20.1	16.3	0.81	2.14	27.6	9.4	4.1	Operation not recommended						
900				20.6	18.0	0.87	2.16	28.0	9.5	4.5	Operation not recommended							
120	4.0	1.0	2.3	Operation not recommended							Operation not recommended							
	6.0	2.4	5.6	700	17.9	16.2	0.91	2.40	26.1	7.4	5.3	Operation not recommended						
				900	18.2	17.6	0.97	2.47	26.6	7.4	5.7	Operation not recommended						
	8.0	3.7	8.6	700	18.0	16.2	0.90	2.33	26.0	7.7	4.9	Operation not recommended						
900				18.4	17.6	0.96	2.40	26.6	7.7	5.4	Operation not recommended							

Multiple Flow Rates (for EWT) are shown in the table above. The lowest flow rate shown is used for geothermal open loop/well water systems with a minimum 50° F. The second flow rate shown is the minimum geothermal closed loop flow rate. The third flow rate shown is optimum for geothermal closed loop and the suggested flow rate for boiler tower applications.

038 - Performance Data

038 - Dual Capacity Low Speed

EWT °F	Flow gpm	WPD		HEATING - EAT 70°F							COOLING - EAT 80/67 °F									
		PSI	FT	Airflow cfm	HC Mbtu/h	Power kW	HE Mbtu/h	LAT °F	COP	HWC Mbtu/h	Airflow cfm	TC Mbtu/h	SC Mbtu/h	S/T Ratio	Power kW	HR Mbtu/h	EER	HWC Mbtu/h		
20	4.0	1.0	2.2	Operation not recommended							Operation not recommended									
	6.0	2.1	4.9	Operation not recommended							Operation not recommended									
	8.0	3.1	7.2	800	17.2	1.69	11.4	89.9	2.97	2.5	Operation not recommended									
1000				17.5	1.70	11.7	86.2	3.02	2.3	Operation not recommended										
30	4.0	0.9	2.2	Operation not recommended							Operation not recommended									
	6.0	2.0	4.7	800	18.3	1.65	12.7	91.2	3.25	2.4	800	23.4	13.6	0.58	0.84	26.3	27.7	-		
				1000	19.1	1.70	13.3	87.7	3.29	2.2	1000	23.8	14.9	0.63	0.89	26.8	26.7	-		
	8.0	3.0	7.0	800	19.9	1.73	14.0	93.0	3.37	2.5	800	23.5	13.6	0.58	0.82	26.6	28.7	-		
				1000	20.3	1.74	14.4	88.8	3.42	2.3	1000	24.1	14.9	0.62	0.86	27.0	28.0	-		
40	4.0	0.9	2.1	Operation not recommended							Operation not recommended									
	6.0	2.0	4.6	800	21.6	1.68	15.9	95.1	3.77	2.5	800	26.2	16.9	0.65	0.93	29.4	28.3	-		
				1000	22.4	1.71	16.6	90.7	3.83	2.3	1000	26.7	18.5	0.69	0.97	30.0	27.5	-		
	8.0	2.9	6.7	800	22.8	1.72	16.9	96.4	3.88	2.6	800	26.4	16.9	0.64	0.90	29.5	29.4	-		
				1000	23.6	1.76	17.6	91.9	3.94	2.4	1000	27.0	18.5	0.69	0.94	30.2	28.7	-		
50	4.0	0.9	2.0	800	24.1	1.71	18.3	97.9	4.14	2.6	800	28.4	19.4	0.68	1.04	31.9	27.4	1.0		
				1000	24.9	1.73	19.0	93.0	4.21	2.4	1000	29.2	21.4	0.73	1.06	32.8	27.6	1.1		
	6.0	1.9	4.4	800	25.0	1.71	19.1	98.9	4.28	2.7	800	28.6	19.5	0.68	1.01	32.1	28.4	0.9		
				1000	25.7	1.73	19.8	93.8	4.35	2.5	1000	29.4	21.5	0.73	1.03	32.9	28.6	1.0		
	8.0	2.8	6.5	800	26.1	1.75	20.2	100.2	4.38	2.8	800	29.1	20.0	0.69	1.00	32.5	29.1	0.9		
1000				26.9	1.77	20.9	94.9	4.45	2.5	1000	29.9	22.1	0.74	1.02	33.4	29.3	1.0			
60	4.0	0.9	2.0	800	27.3	1.75	21.3	101.6	4.56	2.9	800	27.9	19.6	0.70	1.18	31.9	23.6	1.3		
				1000	28.0	1.77	21.9	95.9	4.64	2.6	1000	28.7	21.7	0.76	1.21	32.8	23.8	1.4		
	6.0	1.9	4.3	800	28.4	1.75	22.4	102.9	4.75	3.0	800	28.1	19.7	0.70	1.15	32.1	24.4	1.3		
				1000	29.1	1.76	23.1	96.9	4.83	2.7	1000	28.9	21.8	0.75	1.18	32.9	24.6	1.4		
	8.0	2.7	6.3	800	29.4	1.79	23.3	104.0	4.81	3.0	800	28.6	20.2	0.71	1.14	32.5	25.0	1.2		
1000				30.1	1.80	23.9	97.8	4.89	2.8	1000	29.4	22.4	0.76	1.17	33.4	25.2	1.3			
70	4.0	0.8	1.9	800	30.5	1.80	24.3	105.3	4.96	3.2	800	27.4	19.8	0.72	1.33	32.0	20.6	1.9		
				1000	31.1	1.81	24.9	98.8	5.04	2.9	1000	28.2	21.9	0.78	1.36	32.8	20.8	2.0		
	6.0	1.8	4.2	800	31.8	1.79	25.7	106.8	5.19	3.3	800	27.7	19.9	0.72	1.30	32.1	21.3	1.7		
				1000	32.4	1.79	26.3	100.0	5.29	3.0	1000	28.4	22.0	0.78	1.32	32.9	21.5	1.9		
	8.0	2.7	6.1	800	32.6	1.83	26.4	107.8	5.22	3.4	800	28.1	20.4	0.73	1.29	32.5	21.9	1.6		
1000				33.2	1.83	27.0	100.7	5.32	3.1	1000	28.9	22.6	0.78	1.31	33.4	22.1	1.8			
80	4.0	0.8	1.9	800	33.3	1.83	27.1	108.6	5.34	3.6	800	25.6	19.4	0.76	1.53	30.8	16.8	2.5		
				1000	33.8	1.82	27.6	101.3	5.44	3.3	1000	26.3	21.5	0.82	1.56	31.6	16.9	2.7		
	6.0	1.7	4.0	800	34.9	1.82	28.7	110.4	5.63	3.7	800	25.8	19.5	0.76	1.49	30.9	17.4	2.4		
				1000	35.4	1.81	29.2	102.7	5.74	3.4	1000	26.6	21.6	0.81	1.52	31.7	17.5	2.6		
	8.0	2.6	5.9	800	35.4	1.86	29.1	111.0	5.59	3.8	800	26.3	20.0	0.76	1.48	31.3	17.8	2.2		
1000				35.8	1.84	29.5	103.1	5.70	3.5	1000	27.0	22.2	0.82	1.51	32.1	17.9	2.5			
90	4.0	0.8	1.8	800	36.2	1.86	29.9	111.9	5.71	4.0	800	23.8	19.0	0.80	1.73	29.7	13.8	3.4		
				1000	36.5	1.84	30.2	103.8	5.82	3.7	1000	24.5	21.0	0.86	1.76	30.5	13.9	3.6		
	6.0	1.7	3.9	800	38.1	1.84	31.8	114.1	6.05	4.2	800	24.0	19.1	0.80	1.68	29.8	14.3	3.2		
				1000	38.3	1.82	32.1	105.5	6.18	3.8	1000	24.7	21.2	0.86	1.72	30.5	14.4	3.4		
	8.0	2.5	5.7	800	38.2	1.88	32.0	114.2	5.96	4.3	800	24.2	19.3	0.80	1.65	30.0	14.7	2.9		
1000				38.4	1.85	32.1	105.6	6.08	4.0	1000	25.1	21.7	0.86	1.70	30.9	14.8	3.3			
100	4.0	0.7	1.7	Operation not recommended							Operation not recommended									
	6.0	1.6	3.7	800	22.5	1.85	0.82	1.93	29.1	11.7	4.1	Operation not recommended								
				1000	23.2	20.5	0.89	1.96	29.9	11.8	4.5	Operation not recommended								
	8.0	2.4	5.5	800	22.9	19.0	0.83	1.91	29.4	12.0	3.8	Operation not recommended								
1000				23.6	21.1	0.89	1.95	30.2	12.1	4.2	Operation not recommended									
110	4.0	0.7	1.7	Operation not recommended							Operation not recommended									
	6.0	1.6	3.6	Operation not recommended							800	21.1	18.0	0.85	2.17	28.5	9.7	5.2	Operation not recommended	
				1000	21.6	19.9	0.92	2.21	29.2	9.8	5.7	Operation not recommended								
	8.0	2.3	5.3	Operation not recommended							800	21.4	18.4	0.86	2.15	28.7	10.0	4.8	Operation not recommended	
1000				22.0	20.4	0.93	2.19	29.5	10.0	5.4	Operation not recommended									
120	4.0	0.7	1.6	Operation not recommended							Operation not recommended									
	6.0	1.5	3.5	Operation not recommended							800	18.8	16.2	0.86	2.49	27.3	7.5	6.5	Operation not recommended	
				1000	19.2	17.6	0.92	2.56	27.9	7.5	7.0	Operation not recommended								
	8.0	2.2	5.1	Operation not recommended							800	19.0	16.2	0.85	2.41	27.2	7.9	6.0	Operation not recommended	
1000				19.4	17.6	0.91	2.49	27.9	7.8	6.7	Operation not recommended									

Multiple Flow Rates (for EWT) are shown in the table above. The lowest flow rate shown is used for geothermal open loop/well water systems with a minimum 50° F. The second flow rate shown is the minimum geothermal closed loop flow rate. The third flow rate shown is optimum for geothermal closed loop and the suggested flow rate for boiler tower applications.

038 - Performance Data

038 - Dual Capacity High Speed

EWT °F	Flow gpm	WPD		HEATING - EAT 70°F							COOLING - EAT 80/67 °F							
		PSI	FT	Airflow cfm	HC Mbtu/h	Power kW	HE Mbtu/h	LAT °F	COP	HWC Mbtu/h	Airflow cfm	TC Mbtu/h	SC Mbtu/h	S/T Ratio	Power kW	HR Mbtu/h	EER	HWC Mbtu/h
20	5.0	1.3	3.0	Operation not recommended														
	7.0	2.6	5.9	Operation not recommended														
	9.0	3.7	8.7	1000	24.3	2.22	16.7	92.5	3.21	2.9								
1200				24.9	2.24	17.3	89.2	3.26	2.6									
30	5.0	1.2	2.9	Operation not recommended														
	7.0	2.5	5.8	1000	28.2	2.29	20.4	96.1	3.62	3.1	1000	30.4	18.5	0.61	1.41	35.2	21.5	-
				1200	29.0	2.36	21.0	92.4	3.61	2.8	1200	30.9	20.2	0.65	1.49	36.0	20.7	-
	9.0	3.6	8.4	1000	28.9	2.36	20.8	96.8	3.59	3.2	1000	30.6	18.5	0.61	1.37	35.4	22.3	-
1200				29.6	2.38	21.5	92.8	3.65	2.9	1200	31.3	20.2	0.65	1.44	36.2	21.7	-	
40	5.0	1.2	2.8	Operation not recommended														
	7.0	2.4	5.6	1000	31.9	2.39	23.8	99.6	3.91	3.4	1000	33.6	20.5	0.61	1.56	38.9	21.6	-
				1200	32.9	2.44	24.6	95.4	3.95	3.1	1200	34.2	22.4	0.65	1.63	39.8	21.0	-
	9.0	3.5	8.2	1000	32.6	2.41	24.3	100.2	3.95	3.5	1000	33.8	20.5	0.61	1.51	39.0	22.4	-
1200				33.6	2.47	25.2	95.9	3.99	3.2	1200	34.6	22.4	0.65	1.58	40.0	21.9	-	
50	5.0	1.2	2.7	1000	34.4	2.44	26.1	101.9	4.14	3.7	1000	34.9	20.5	0.59	1.78	41.0	19.6	1.9
				1200	35.4	2.47	27.0	97.3	4.20	3.4	1200	36.7	22.8	0.62	1.87	43.1	19.6	2.0
	7.0	2.3	5.4	1000	35.7	2.49	27.1	103.0	4.19	3.8	1000	35.7	20.7	0.58	1.68	41.4	21.2	1.8
				1200	36.8	2.53	28.2	98.4	4.27	3.5	1200	37.5	23.0	0.61	1.76	43.5	21.3	1.9
	9.0	3.4	7.9	1000	36.5	2.52	27.9	103.8	4.25	3.9	1000	36.0	22.1	0.62	1.64	41.6	22.0	1.7
				1200	37.6	2.55	28.9	99.0	4.32	3.6	1200	37.9	24.6	0.65	1.72	43.8	22.0	1.8
60	5.0	1.1	2.6	1000	37.2	2.53	28.6	104.5	4.32	4.2	1000	35.5	22.7	0.64	1.96	42.2	18.1	2.3
				1200	38.4	2.54	29.7	99.6	4.43	3.8	1200	37.2	25.2	0.68	2.04	44.2	18.2	2.4
	7.0	2.3	5.3	1000	38.9	2.60	30.0	106.0	4.39	4.3	1000	36.3	22.9	0.63	1.86	42.7	19.5	2.2
				1200	40.2	2.61	31.2	101.0	4.50	4.0	1200	38.1	25.4	0.67	1.94	44.7	19.7	2.3
	9.0	3.3	7.6	1000	39.8	2.62	30.9	106.9	4.45	4.4	1000	36.7	24.2	0.66	1.81	42.9	20.2	2.0
				1200	41.2	2.64	32.2	101.8	4.58	4.1	1200	38.5	26.8	0.70	1.90	45.0	20.3	2.2
70	5.0	1.1	2.5	1000	40.1	2.61	31.2	107.1	4.50	4.7	1000	36.1	24.9	0.69	2.13	43.4	16.9	2.9
				1200	42.7	2.67	33.6	102.9	4.69	4.3	1200	37.7	27.7	0.73	2.21	45.2	17.0	3.0
	7.0	2.2	5.1	1000	42.1	2.70	32.9	109.0	4.58	4.8	1000	37.0	25.2	0.68	2.04	44.0	18.2	2.7
				1200	43.5	2.70	34.3	103.6	4.73	4.4	1200	38.6	27.9	0.72	2.11	45.8	18.3	2.9
	9.0	3.2	7.4	1000	43.2	2.73	33.9	110.0	4.64	5.0	1000	37.4	26.2	0.70	1.99	44.2	18.8	2.5
				1200	44.7	2.72	35.4	104.5	4.82	4.6	1200	39.1	29.0	0.74	2.07	46.2	18.9	2.8
80	5.0	1.1	2.5	1000	43.3	2.73	34.0	110.1	4.65	5.2	1000	34.8	24.6	0.71	2.34	42.8	14.8	3.6
				1200	44.8	2.71	35.6	104.6	4.85	4.8	1200	36.2	27.3	0.76	2.41	44.4	15.0	3.8
	7.0	2.1	4.9	1000	45.8	2.84	36.1	112.4	4.73	5.4	1000	35.7	24.9	0.70	2.26	43.4	15.8	3.3
				1200	47.3	2.81	37.7	106.5	4.94	5.0	1200	37.2	27.6	0.74	2.33	45.1	16.0	3.6
	9.0	3.1	7.1	1000	47.1	2.87	37.3	113.6	4.80	5.6	1000	36.1	25.5	0.71	2.21	43.7	16.3	3.1
				1200	48.7	2.83	39.0	107.6	5.04	5.1	1200	37.6	28.3	0.75	2.28	45.4	16.5	3.4
90	5.0	1.0	2.4	1000	46.5	2.84	36.8	113.0	4.79	5.9	1000	33.4	24.3	0.73	2.55	42.1	13.1	4.4
				1200	48.1	2.80	38.6	107.1	5.04	5.4	1200	34.6	27.0	0.78	2.62	43.5	13.2	4.7
	7.0	2.0	4.7	1000	49.4	2.97	39.2	115.7	4.87	6.0	1000	34.4	24.6	0.71	2.48	42.9	13.9	4.1
				1200	51.1	2.92	41.2	109.5	5.14	5.6	1200	35.7	27.3	0.76	2.54	44.4	14.0	4.5
	9.0	3.0	6.9	1000	50.9	3.01	40.7	117.2	4.95	6.2	1000	35.2	25.2	0.72	2.37	43.3	14.9	3.9
				1200	52.7	2.94	42.7	110.7	5.25	5.8	1200	36.1	27.5	0.76	2.49	44.6	14.5	4.3
100	5.0	1.0	2.3	Operation not recommended														
	7.0	2.0	4.6	1000	31.6	2.40	24.0	0.76	2.77	41.0	11.4	5.1						
				1200	32.6	26.7	0.82	2.81	42.2	11.6	5.5							
	9.0	2.9	6.6	1000	31.9	24.0	0.75	2.72	41.2	11.7	4.8							
1200				26.5	0.80	2.76	42.4	11.9	5.3									
110	5.0	1.0	2.2	Operation not recommended														
	7.0	1.9	4.4	Operation not recommended														
				1000	28.7	23.4	0.82	3.05	39.1	9.4	6.2							
	1200	29.5	26.0	0.88	3.07	40.0	9.6	6.8										
9.0	2.8	6.4	1000	29.0	23.1	0.80	3.00	39.2	9.7	5.8								
			1200	29.8	25.5	0.86	3.03	40.1	9.8	6.4								
120	5.0	0.9	2.1	Operation not recommended														
	7.0	1.8	4.2	Operation not recommended														
				1000	26.9	22.8	0.85	3.38	38.4	8.0	7.5							
	1200	27.4	24.7	0.90	3.46	39.2	7.9	8.1										
9.0	2.7	6.1	1000	27.1	22.8	0.84	3.27	38.3	8.3	7.0								
			1200	27.7	24.7	0.89	3.37	39.2	8.2	7.7								

Multiple Flow Rates (for EWT) are shown in the table above. The lowest flow rate shown is used for geothermal open loop/well water systems with a minimum 50° F. The second flow rate shown is the minimum geothermal closed loop flow rate. The third flow rate shown is optimum for geothermal closed loop and the suggested flow rate for boiler tower applications.

3/7/17

049 - Performance Data

049 - Dual Capacity Low Speed

EWT °F	Flow gpm	WPD		HEATING - EAT 70°F							COOLING - EAT 80/67 °F								
		PSI	FT	Airflow cfm	HC Mbtu/h	Power kW	HE Mbtu/h	LAT °F	COP	HWC Mbtu/h	Airflow cfm	TC Mbtu/h	SC Mbtu/h	S/T Ratio	Power kW	HR Mbtu/h	EER	HWC Mbtu/h	
20	5.0	0.9	2.1	Operation not recommended							Operation not recommended								
	8.0	2.2	5.1	Operation not recommended							Operation not recommended								
	11.0	3.6	8.4	1200	21.1	2.25	13.4	86.3	2.75	4.2	Operation not recommended								
				1400	21.6	2.28	13.8	84.3	2.78	3.8	Operation not recommended								
30	5.0	0.9	2.1	Operation not recommended							Operation not recommended								
	8.0	2.2	5.0	1200	25.1	2.28	17.3	89.3	3.22	4.3	1200	34.3	22.1	0.64	1.22	38.4	28.2	-	
				1400	25.8	2.30	18.0	87.1	3.29	3.9	1400	34.8	24.1	0.69	1.28	39.2	27.2	-	
	11.0	3.5	8.2	1200	26.0	2.30	18.2	90.1	3.31	4.4	1200	34.5	22.1	0.64	1.18	38.5	29.2	-	
				1400	26.6	2.33	18.7	87.6	3.35	4.0	1400	35.3	24.1	0.68	1.24	39.5	28.5	-	
	40	5.0	0.9	2.0	Operation not recommended							Operation not recommended							
8.0		2.1	4.8	1200	30.9	2.34	22.9	93.8	3.86	4.5	1200	37.4	25.5	0.68	1.35	42.0	27.8	-	
				1400	32.0	2.34	24.0	91.2	4.00	4.2	1400	38.1	27.8	0.73	1.41	42.9	27.0	-	
11.0		3.4	7.9	1200	31.9	2.36	23.9	94.6	3.96	4.7	1200	37.7	25.5	0.68	1.31	42.1	28.9	-	
				1400	33.0	2.38	24.9	91.8	4.07	4.2	1400	38.5	27.8	0.72	1.37	43.2	28.2	-	
50		5.0	0.8	2.0	1200	34.1	2.33	26.1	96.3	4.29	4.8	1200	39.4	26.6	0.68	1.74	45.3	22.7	1.6
	1400				35.2	2.33	27.2	93.3	4.43	4.4	1400	40.6	31.4	0.77	1.81	46.8	22.4	1.7	
	8.0	2.0	4.7	1200	36.7	2.40	28.5	98.4	4.48	4.9	1200	40.2	26.7	0.66	1.50	45.4	26.7	1.5	
				1400	38.1	2.39	30.0	95.2	4.68	4.5	1400	41.5	31.5	0.76	1.58	46.8	26.3	1.6	
	11.0	3.3	7.7	1200	38.1	2.42	29.9	99.4	4.62	5.1	1200	40.5	26.7	0.66	1.42	45.6	28.6	1.4	
				1400	39.4	2.42	31.1	96.1	4.77	4.6	1400	41.7	31.5	0.76	1.49	46.8	28.0	1.5	
60	5.0	0.8	1.9	1200	36.3	2.40	28.1	98.0	4.43	5.2	1200	37.0	26.2	0.71	1.91	43.5	19.3	2.3	
				1400	37.6	2.38	29.4	94.8	4.62	4.8	1400	38.2	30.9	0.81	2.00	45.0	19.1	2.4	
	8.0	2.0	4.5	1200	39.2	2.46	30.8	100.3	4.68	5.4	1200	37.6	26.4	0.70	1.70	43.4	22.1	2.1	
				1400	40.8	2.43	32.5	97.0	4.92	5.0	1400	38.8	31.1	0.80	1.78	44.8	21.8	2.3	
	11.0	3.2	7.4	1200	40.9	2.48	32.4	101.6	4.83	5.5	1200	38.0	26.5	0.70	1.61	43.5	23.6	1.9	
				1400	42.4	2.45	34.0	98.0	5.07	5.1	1400	39.2	31.2	0.79	1.69	44.9	23.3	2.2	
70	5.0	0.8	1.8	1200	38.5	2.47	30.1	99.7	4.57	5.8	1200	34.6	25.8	0.75	2.09	41.8	16.6	3.2	
				1400	42.0	2.46	33.6	97.8	5.00	5.4	1400	35.7	30.4	0.85	2.19	43.2	16.3	3.4	
	8.0	1.9	4.4	1200	41.8	2.51	33.2	102.2	4.88	6.0	1200	35.0	26.1	0.75	1.89	42.0	18.5	3.0	
				1400	43.4	2.47	35.0	98.7	5.16	5.5	1400	36.1	30.7	0.85	1.98	42.8	18.2	3.2	
	11.0	3.1	7.2	1200	43.7	2.54	35.0	103.7	5.04	6.1	1200	35.6	26.2	0.74	1.81	42.3	19.7	2.8	
				1400	45.3	2.48	36.8	100.0	5.35	5.7	1400	36.7	30.8	0.84	1.88	43.1	19.5	3.1	
80	5.0	0.8	1.8	1200	41.3	2.50	32.7	101.9	4.83	6.5	1200	32.4	24.7	0.76	2.33	40.4	13.9	4.4	
				1400	42.9	2.46	34.5	98.4	5.11	6.0	1400	33.4	29.1	0.87	2.43	41.7	13.8	4.6	
	8.0	1.8	4.2	1200	44.8	2.53	36.2	104.6	5.19	6.7	1200	32.6	25.0	0.77	2.16	40.0	15.1	4.1	
				1400	46.7	2.47	38.2	100.9	5.54	6.1	1400	33.6	29.4	0.88	2.25	41.2	14.9	4.4	
	11.0	3.0	6.9	1200	47.1	2.56	38.4	106.4	5.39	6.9	1200	33.3	25.2	0.76	2.07	40.4	16.1	3.8	
				1400	49.0	2.49	40.5	102.4	5.77	6.3	1400	34.4	29.6	0.86	2.16	41.7	15.9	4.2	
90	5.0	0.7	1.7	1200	44.1	2.54	35.4	104.0	5.08	7.2	1200	30.2	23.6	0.78	2.56	38.3	11.8	5.9	
				1400	45.8	2.49	37.3	100.3	5.40	6.7	1400	31.2	27.7	0.89	2.67	40.3	11.7	6.2	
	8.0	1.8	4.1	1200	47.9	2.56	39.2	107.0	5.50	7.4	1200	30.2	23.9	0.79	2.43	38.5	12.4	5.5	
				1400	49.9	2.47	41.5	103.0	5.92	6.9	1400	31.0	28.1	0.91	2.52	39.6	12.3	5.9	
	11.0	2.9	6.7	1200	50.6	2.58	41.8	109.0	5.74	7.7	1200	31.5	26.3	0.83	2.35	39.5	13.4	5.1	
				1400	52.7	2.50	44.2	104.9	6.18	7.1	1400	32.0	28.4	0.89	2.43	40.3	13.2	5.6	
100	5.0	0.7	1.6	Operation not recommended							Operation not recommended								
	8.0	1.7	3.9	1200	27.5	2.24	0.81	2.73	36.9	10.1	7.1	Operation not recommended							
				1400	28.4	2.64	0.93	2.84	38.1	10.0	7.7	Operation not recommended							
	11.0	2.8	6.5	1200	28.6	2.27	0.80	2.64	37.6	10.8	6.6	Operation not recommended							
1400				29.4	2.67	0.91	2.75	38.8	10.7	7.3	Operation not recommended								
110	5.0	0.7	1.6	Operation not recommended							Operation not recommended								
	8.0	1.6	3.8	Operation not recommended							1200	24.9	20.9	0.84	3.04	35.3	8.2	9.0	
				1400	25.7	24.6	0.96	3.16	36.5	8.1	9.8								
	11.0	2.7	6.2	Operation not recommended							1200	26.1	21.3	0.82	2.94	36.1	8.9	8.4	
1400				26.8	25.0	0.93	3.07	37.3	8.7	9.3									
120	5.0	0.7	1.5	Operation not recommended							Operation not recommended								
	8.0	1.6	3.6	Operation not recommended							1200	23.9	21.4	0.90	3.45	35.6	6.9	11.2	
				1400	24.3	23.2	0.95	3.54	36.4	6.9	12.1								
	11.0	2.6	6.0	Operation not recommended							1200	24.1	21.4	0.89	3.34	35.5	7.2	10.4	
1400				24.6	23.2	0.94	3.44	36.3	7.2	11.5									

Multiple Flow Rates (for EWT) are shown in the table above. The lowest flow rate shown is used for geothermal open loop/well water systems with a minimum 50° F. The second flow rate shown is the minimum geothermal closed loop flow rate. The third flow rate shown is optimum for geothermal closed loop and the suggested flow rate for boiler tower applications.

3/7/17

049 - Performance Data

049 - Dual Capacity High Speed

EWT °F	Flow gpm	WPD		HEATING - EAT 70°F							COOLING - EAT 80/67 °F											
		PSI	FT	Airflow cfm	HC Mbtu/h	Power kW	HE Mbtu/h	LAT °F	COP	HWC Mbtu/h	Airflow cfm	TC Mbtu/h	SC Mbtu/h	S/T Ratio	Power kW	HR Mbtu/h	EER	HWC Mbtu/h				
20	6.0	1.3	3.1	Operation not recommended																		
	9.0	2.8	6.5	Operation not recommended																		
	12.0	4.3	9.9	1400	35.6	2.95	25.5	93.5	3.53	5.3	1600	36.6	3.03	26.3	91.2	3.54	4.8	Operation not recommended				
30	6.0	1.3	3.0	Operation not recommended							Operation not recommended											
	9.0	2.7	6.3	1400	37.1	3.15	26.4	94.5	3.45	5.6	1400	42.2	29.5	0.70	1.85	48.5	22.9	-				
	12.0	4.2	9.6	1600	38.3	3.17	27.4	92.1	3.53	5.2	1600	42.9	32.2	0.75	1.94	49.6	22.1	-				
				1400	38.3	3.14	27.6	95.3	3.57	5.6	1400	42.5	29.5	0.69	1.79	48.6	23.7	-				
1600	39.4	3.22	28.4	92.8	3.59	5.3	1600	43.5	32.2	0.74	1.88	49.9	23.1	-								
40	6.0	1.2	2.9	Operation not recommended							Operation not recommended											
	9.0	2.6	6.1	1400	42.0	3.28	30.8	97.8	3.76	6.2	1400	46.5	32.5	0.70	2.11	53.7	22.0	-				
	12.0	4.0	9.3	1600	43.5	3.28	32.3	95.2	3.89	5.7	1600	47.4	35.5	0.75	2.22	54.9	21.4	-				
				1400	43.4	3.30	32.1	98.7	3.85	6.4	1400	46.9	32.5	0.69	2.05	53.9	22.8	-				
1600	44.9	3.32	33.5	96.0	3.96	5.8	1600	47.9	35.5	0.74	2.15	55.2	22.3	-								
50	6.0	1.2	2.8	1400	43.5	3.29	32.3	98.8	3.88	6.7	1400	49.4	32.8	0.66	2.81	58.0	17.6	3.0				
				1600	44.9	3.29	33.7	96.0	4.00	6.2	1600	50.9	38.6	0.76	2.93	60.5	17.4	3.2				
	9.0	2.6	5.9	1400	46.9	3.40	35.3	101.0	4.05	6.9	1400	50.5	32.9	0.65	2.43	58.6	20.7	2.8				
				1600	48.7	3.38	37.2	98.2	4.23	6.4	1600	52.0	38.8	0.75	2.55	60.7	20.4	3.0				
	12.0	3.9	9.1	1400	48.7	3.42	37.0	102.2	4.17	7.2	1400	50.8	32.9	0.65	2.29	58.8	22.2	2.6				
				1600	50.3	3.42	38.6	99.1	4.31	6.5	1600	52.3	38.8	0.74	2.41	60.9	21.7	2.9				
60	6.0	1.2	2.7	1400	47.7	3.47	35.8	101.5	4.03	7.6	1400	48.0	32.1	0.67	2.99	58.2	16.1	3.7				
				1600	49.4	3.45	37.6	98.6	4.20	7.0	1600	49.5	37.9	0.77	3.12	60.1	15.9	3.9				
	9.0	2.5	5.7	1400	51.6	3.56	39.5	104.1	4.25	7.8	1400	48.7	32.4	0.66	2.65	57.8	18.4	3.4				
				1600	53.6	3.51	41.6	101.0	4.47	7.2	1600	50.2	38.1	0.76	2.77	59.7	18.1	3.7				
	12.0	3.8	8.8	1400	53.8	3.59	41.6	105.6	4.39	8.0	1400	49.3	32.5	0.66	2.52	57.9	19.6	3.2				
				1600	55.7	3.55	43.6	102.2	4.61	7.4	1600	50.8	38.2	0.75	2.63	59.8	19.3	3.5				
70	6.0	1.1	2.6	1400	51.9	3.65	39.4	104.3	4.17	8.5	1400	46.5	31.5	0.68	3.17	57.2	14.7	4.6				
				1600	57.3	3.58	45.1	103.2	4.69	7.9	1600	48.0	37.1	0.77	3.32	58.3	14.5	4.9				
	9.0	2.4	5.5	1400	56.3	3.71	43.6	107.2	4.45	8.8	1400	47.0	31.9	0.68	2.87	57.8	16.4	4.3				
				1600	58.5	3.65	46.1	103.9	4.70	8.1	1600	48.5	37.4	0.77	3.00	58.7	16.2	4.6				
	12.0	3.7	8.5	1400	58.9	3.76	46.1	108.9	4.60	9.0	1400	47.8	32.0	0.67	2.74	57.9	17.4	4.0				
				1600	61.1	3.67	48.6	105.4	4.88	8.3	1600	49.3	37.6	0.76	2.85	59.0	17.3	4.4				
80	6.0	1.1	2.5	1400	55.6	3.83	42.5	106.7	4.26	9.6	1400	43.8	30.5	0.70	3.36	54.3	13.0	5.8				
				1600	57.7	3.76	44.9	103.4	4.50	8.8	1600	45.2	35.9	0.79	3.51	56.2	12.9	6.2				
	9.0	2.3	5.4	1400	60.3	3.87	47.1	109.9	4.57	9.8	1400	44.1	30.9	0.70	3.12	54.7	14.1	5.4				
				1600	62.8	3.77	49.9	106.3	4.88	9.1	1600	45.4	36.3	0.80	3.25	56.5	14.0	5.9				
	12.0	3.5	8.2	1400	63.4	3.91	50.1	111.9	4.75	10.1	1400	45.1	31.1	0.69	2.99	55.2	15.1	5.0				
				1600	66.0	3.81	53.0	108.2	5.08	9.4	1600	46.5	36.6	0.79	3.11	57.1	14.9	5.6				
90	6.0	1.1	2.4	1400	59.2	4.01	45.6	109.2	4.33	10.7	1400	41.1	29.5	0.72	3.55	53.3	11.6	7.3				
				1600	61.5	3.92	48.2	105.6	4.60	9.9	1600	42.5	34.7	0.82	3.70	55.1	11.5	7.7				
	9.0	2.2	5.2	1400	64.4	4.03	50.7	112.6	4.69	11.1	1400	41.1	29.9	0.73	3.37	53.6	12.2	6.8				
				1600	67.1	3.90	53.8	108.8	5.04	10.2	1600	42.3	35.2	0.83	3.49	54.2	12.1	7.4				
	12.0	3.4	7.9	1400	68.0	4.07	54.1	114.9	4.89	11.4	1400	42.9	33.3	0.78	3.27	54.1	13.1	6.3				
				1600	70.8	3.94	57.4	111.0	5.27	10.6	1600	43.6	35.5	0.81	3.37	55.1	12.9	7.0				
100	6.0	1.0	2.3	Operation not recommended																		
	9.0	2.2	5.0	Operation not recommended																		
	12.0	3.3	7.6	1400	38.5	28.9	0.75	3.71	51.1	10.4	8.4	1600	39.6	34.1	0.86	3.86	52.8	10.3	9.2			
				1400	39.9	29.4	0.74	3.58	52.1	11.1	7.8	1600	41.1	34.5	0.84	3.74	53.8	11.0	8.7			
110	6.0	1.0	2.3	Operation not recommended																		
	9.0	2.1	4.8	Operation not recommended																		
	12.0	3.2	7.3	1400	35.8	28.0	0.78	4.06	49.6	8.8	10.3	1600	37.0	33.0	0.89	4.23	51.4	8.7	11.2			
				1400	37.5	28.5	0.76	3.93	50.9	9.5	9.6	1600	38.5	33.5	0.87	4.10	52.5	9.4	10.7			
120	6.0	0.9	2.2	Operation not recommended																		
	9.0	2.0	4.6	Operation not recommended																		
	12.0	3.0	7.0	1400	34.0	29.6	0.87	4.57	49.6	7.4	12.5	1600	34.6	32.1	0.93	4.69	50.6	7.4	13.5			
				1400	34.3	29.6	0.86	4.42	49.4	7.8	11.6	1600	35.0	32.1	0.92	4.56	50.6	7.7	12.9			

Multiple Flow Rates (for EWT) are shown in the table above. The lowest flow rate shown is used for geothermal open loop/well water systems with a minimum 50° F. The second flow rate shown is the minimum geothermal closed loop flow rate. The third flow rate shown is optimum for geothermal closed loop and the suggested flow rate for boiler tower applications.

3/7/17

064 - Performance Data

064 - Dual Capacity Low Speed

EWT °F	Flow gpm	WPD		HEATING - EAT 70°F							COOLING - EAT 80/67 °F							
		PSI	FT	Airflow cfm	HC Mbtu/h	Power kW	HE Mbtu/h	LAT °F	COP	HWC Mbtu/h	Airflow cfm	TC Mbtu/h	SC Mbtu/h	S/T Ratio	Power kW	HR Mbtu/h	EER	HWC Mbtu/h
20	6.0	1.1	2.5	Operation not recommended							Operation not recommended							
	10.0	3.4	7.8	Operation not recommended							Operation not recommended							
	14.0	5.8	13.4	1200	26.2	2.79	16.7	90.2	2.76	4.9	Operation not recommended							
				1500	26.9	2.80	17.3	86.6	2.82	4.5	Operation not recommended							
30	6.0	1.1	2.5	Operation not recommended							Operation not recommended							
	10.0	3.3	7.6	1200	30.1	2.85	20.4	89.3	3.10	5.0	1200	43.4	26.3	0.61	1.50	48.5	28.9	-
	14.0	5.6	13.0	1200	31.5	2.88	21.7	94.3	3.21	5.1	1200	43.6	26.3	0.60	1.46	48.6	29.9	-
				1500	32.3	2.89	22.4	89.9	3.28	4.7	1500	44.7	28.7	0.64	1.53	49.9	29.2	-
40	6.0	1.0	2.4	Operation not recommended							Operation not recommended							
	10.0	3.2	7.4	1200	35.5	2.93	25.5	97.4	3.55	5.3	1200	47.0	29.7	0.63	1.67	52.7	28.2	-
				1500	36.4	2.94	26.4	92.5	3.64	4.9	1500	47.9	32.5	0.68	1.75	53.9	27.4	-
	14.0	5.4	12.6	1200	36.6	2.94	26.6	98.3	3.66	5.5	1200	47.4	29.7	0.63	1.62	52.9	29.3	-
1500				37.6	2.95	27.6	93.2	3.74	5.0	1500	48.5	32.5	0.67	1.69	54.2	28.7	-	
50	6.0	1.0	2.3	1200	40.1	2.95	30.1	101.0	3.99	5.6	1200	50.5	31.6	0.63	1.87	56.4	27.0	2.0
				1500	41.2	2.95	31.1	95.4	4.10	5.2	1500	51.9	35.9	0.69	1.97	58.2	26.4	2.1
	10.0	3.1	7.2	1200	40.7	3.00	30.5	101.4	3.98	5.7	1200	50.6	31.9	0.63	1.80	56.7	28.1	1.9
				1500	41.7	2.98	31.5	95.7	4.09	5.3	1500	52.1	36.2	0.70	1.88	58.5	27.6	2.0
	14.0	5.3	12.2	1200	42.0	3.02	31.7	102.4	4.08	5.9	1200	50.7	31.9	0.63	1.77	56.9	28.7	1.7
				1500	42.9	3.00	32.7	96.5	4.19	5.4	1500	52.2	36.2	0.69	1.85	28.7	28.2	1.9
60	6.0	1.0	2.2	1200	44.9	3.02	34.6	104.7	4.35	6.1	1200	48.3	30.9	0.64	2.12	55.4	22.8	2.8
				1500	45.9	3.00	35.6	98.3	4.48	5.7	1500	49.8	34.9	0.70	2.22	57.0	22.4	3.0
	10.0	3.0	6.9	1200	46.3	3.08	35.8	105.7	4.41	6.3	1200	48.5	31.2	0.64	2.05	55.6	23.6	2.6
				1500	47.0	3.03	36.7	99.0	4.55	5.8	1500	50.0	35.2	0.70	2.15	57.3	23.3	2.9
	14.0	5.1	11.8	1200	47.4	3.10	36.8	106.6	4.48	6.5	1200	48.7	31.3	0.64	2.01	55.7	24.2	2.5
				1500	48.2	3.06	37.7	99.7	4.61	6.0	1500	50.2	35.3	0.70	2.11	57.4	23.8	2.7
70	6.0	0.9	2.2	1200	49.7	3.10	39.1	108.4	4.70	6.8	1200	46.2	30.2	0.65	2.38	54.3	19.4	4.0
				1500	49.6	3.07	39.1	100.6	4.74	6.3	1500	47.6	33.9	0.71	2.48	56.1	19.2	4.2
	10.0	2.9	6.7	1200	51.8	3.15	41.1	110.0	4.82	7.0	1200	46.5	30.5	0.66	2.31	54.4	20.1	3.7
				1500	52.4	3.09	41.9	102.4	4.98	6.5	1500	47.9	34.3	0.72	2.41	56.1	19.9	4.0
	14.0	4.9	11.4	1200	52.8	3.19	42.0	110.8	4.85	7.2	1200	46.8	30.6	0.65	2.26	54.5	20.7	3.5
				1500	53.4	3.12	42.8	103.0	5.02	6.6	1500	48.2	34.4	0.71	2.36	56.3	20.4	3.9
80	6.0	0.9	2.1	1200	53.6	3.17	42.8	111.4	4.96	7.6	1200	43.1	28.6	0.66	2.71	52.3	15.9	5.5
				1500	54.1	3.10	43.5	103.4	5.12	7.0	1500	44.4	31.9	0.72	2.81	53.9	15.8	5.9
	10.0	2.8	6.5	1200	56.6	3.22	45.6	113.7	5.16	7.8	1200	43.4	28.9	0.66	2.64	52.5	16.4	5.2
				1500	56.9	3.12	46.2	105.1	5.34	7.2	1500	44.7	32.3	0.72	2.75	54.1	16.3	5.6
	14.0	4.8	11.0	1200	57.3	3.26	46.2	114.2	5.15	8.0	1200	43.7	29.1	0.66	2.60	52.6	16.8	4.8
				1500	57.5	3.17	46.7	105.5	5.32	7.4	1500	45.1	32.5	0.72	2.70	54.3	16.7	5.3
90	6.0	0.9	2.0	1200	57.5	3.23	46.5	114.3	5.22	8.5	1200	39.9	27.0	0.68	3.05	50.3	13.1	7.4
				1500	57.6	3.14	46.9	105.6	5.37	7.8	1500	41.1	30.0	0.73	3.13	51.8	13.1	7.8
	10.0	2.7	6.2	1200	61.3	3.28	50.1	117.3	5.48	8.7	1200	40.4	27.2	0.67	2.98	50.5	13.6	6.9
				1500	61.3	3.16	50.6	107.9	5.69	8.1	1500	41.6	30.3	0.73	3.08	52.1	13.5	7.5
	14.0	4.6	10.6	1200	61.7	3.33	50.4	117.6	5.44	9.0	1200	40.2	28.0	0.70	2.94	50.7	13.7	6.4
				1500	61.6	3.21	50.6	108.0	5.62	8.3	1500	42.0	30.6	0.73	3.03	52.3	13.9	7.1
100	6.0	0.8	2.0	Operation not recommended							Operation not recommended							
	10.0	2.6	6.0	1200	37.6	26.3	0.70	3.40	49.2	11.1	9.0	Operation not recommended						
				1500	38.7	29.1	0.75	3.49	50.7	11.1	9.7	Operation not recommended						
	14.0	4.4	10.3	1200	38.0	26.6	0.70	3.35	49.4	11.3	8.3	Operation not recommended						
1500				39.2	29.5	0.75	3.44	50.9	11.4	9.2	Operation not recommended							
110	6.0	0.8	1.9	Operation not recommended							Operation not recommended							
	10.0	2.5	5.8	1200	34.8	25.4	0.73	3.82	47.9	9.1	11.3	Operation not recommended						
				1500	35.9	27.9	0.78	3.90	49.2	9.2	12.3	Operation not recommended						
	14.0	4.3	9.9	1200	35.3	25.8	0.73	3.76	48.2	9.4	10.5	Operation not recommended						
1500				36.4	28.3	0.78	3.84	49.5	9.5	11.7	Operation not recommended							
120	6.0	0.8	1.8	Operation not recommended							Operation not recommended							
	10.0	2.4	5.6	1200	31.8	24.0	0.76	4.35	46.7	7.3	14.0	Operation not recommended						
				1500	32.4	26.1	0.81	4.46	47.6	7.3	15.2	Operation not recommended						
	14.0	4.1	9.5	1200	32.1	24.0	0.75	4.21	46.5	7.6	13.0	Operation not recommended						
1500				32.8	26.1	0.80	4.34	47.6	7.6	14.5	Operation not recommended							

Multiple Flow Rates (for EWT) are shown in the table above. The lowest flow rate shown is used for geothermal open loop/well water systems with a minimum 50° F. The second flow rate shown is the minimum geothermal closed loop flow rate. The third flow rate shown is optimum for geothermal closed loop and the suggested flow rate for boiler tower applications.

064 - Performance Data

064 - Dual Capacity High Speed

EWT °F	Flow gpm	WPD		HEATING - EAT 70°F							COOLING - EAT 80/67 °F							
		PSI	FT	Airflow cfm	HC Mbtu/h	Power kW	HE Mbtu/h	LAT °F	COP	HWC Mbtu/h	Airflow cfm	TC Mbtu/h	SC Mbtu/h	S/T Ratio	Power kW	HR Mbtu/h	EER	HWC Mbtu/h
20	8.0	1.9	4.3	Operation not recommended							Operation not recommended							
	12.0	4.2	9.7	Operation not recommended							Operation not recommended							
	16.0	6.7	15.4	1500	371	3.77	24.3	92.9	2.89	6.2	Operation not recommended							
				1800	37.7	3.80	24.7	89.4	2.91	5.6	Operation not recommended							
30	8.0	1.8	4.2	Operation not recommended							Operation not recommended							
	12.0	4.1	9.5	1500	45.3	3.68	32.7	97.9	3.61	6.5	1500	56.2	34.2	0.61	2.49	64.7	22.5	-
				1800	46.5	3.91	33.1	93.9	3.48	6.0	1800	57.1	37.4	0.65	2.63	66.1	21.7	-
	16.0	6.5	14.9	1500	46.3	3.92	32.9	98.6	3.46	6.7	1500	56.5	34.2	0.61	2.42	64.8	23.4	-
				1800	47.0	3.95	33.5	94.2	3.49	6.1	1800	57.9	37.4	0.65	2.54	66.6	22.8	-
40	8.0	1.8	4.0	Operation not recommended							Operation not recommended							
	12.0	4.0	9.2	1500	51.5	3.91	38.2	101.8	3.86	7.2	1500	60.4	37.7	0.62	2.75	69.8	22.0	-
				1800	52.7	4.07	38.8	97.1	3.79	6.6	1800	61.5	41.2	0.67	2.88	71.3	21.3	-
	16.0	6.3	14.5	1500	52.3	3.98	38.7	102.3	3.86	7.4	1500	60.8	37.7	0.62	2.67	69.9	22.8	-
				1800	53.5	4.12	39.5	97.5	3.81	6.7	1800	62.2	41.2	0.66	2.79	71.7	22.3	-
50	8.0	1.7	3.9	1500	54.6	4.05	40.8	103.7	3.95	7.8	1500	63.9	40.5	0.63	2.97	74.0	21.5	4.0
				1800	55.8	4.18	41.5	98.7	3.91	7.2	1800	65.2	44.1	0.68	3.16	76.0	20.6	4.2
	12.0	3.8	8.9	1500	57.8	4.13	43.7	105.7	4.10	8.0	1500	64.5	40.9	0.63	2.91	74.5	22.2	3.7
				1800	58.9	4.23	44.5	100.3	4.08	7.4	1800	65.8	44.5	0.68	3.09	76.4	21.3	4.0
16.0	6.1	14.0	1500	58.7	4.18	44.5	106.3	4.12	8.2	1500	65.2	41.4	0.63	2.86	75.0	22.8	3.4	
				1800	60.0	4.28	45.4	100.9	4.11	7.5	1800	66.5	44.9	0.68	3.04	76.9	21.9	3.8
60	8.0	1.6	3.8	1500	60.7	4.29	46.0	107.5	4.15	8.7	1500	61.5	39.4	0.64	3.22	72.4	19.1	4.8
				1800	62.0	4.36	47.1	101.9	4.17	8.0	1800	63.0	42.8	0.68	3.42	74.7	18.4	5.1
	12.0	3.7	8.6	1500	63.5	4.36	48.6	109.2	4.27	9.0	1500	62.1	39.8	0.64	3.15	72.8	19.7	4.5
				1800	64.8	4.42	49.8	103.3	4.30	8.3	1800	63.7	43.2	0.68	3.35	75.1	19.0	4.9
16.0	5.9	13.6	1500	64.8	4.41	49.8	110.0	4.31	9.2	1500	62.7	40.2	0.64	3.10	73.3	20.2	4.2	
				1800	66.3	4.46	51.1	104.1	4.36	8.5	1800	64.3	43.7	0.68	3.30	75.5	19.5	4.6
70	8.0	1.6	3.7	1500	66.7	4.52	51.3	111.2	4.33	9.8	1500	59.0	38.3	0.65	3.46	70.8	17.0	6.1
				1800	68.4	4.54	52.9	105.2	4.42	9.0	1800	60.8	41.6	0.68	3.69	73.4	16.5	6.4
	12.0	3.6	8.3	1500	69.2	4.59	53.5	112.7	4.42	10.1	1500	59.6	38.6	0.65	3.39	71.2	17.6	5.7
				1800	70.7	4.60	55.1	106.4	4.51	9.3	1800	61.5	41.9	0.68	3.61	73.8	17.0	6.1
16.0	5.7	13.1	1500	70.9	4.64	55.1	113.8	4.48	10.4	1500	60.2	39.0	0.65	3.34	71.6	18.0	5.3	
				1800	72.6	4.64	56.8	107.3	4.59	9.6	1800	62.1	42.4	0.68	3.55	74.2	17.5	5.8
80	8.0	1.5	3.5	1500	71.5	4.72	55.4	114.2	4.44	11.0	1500	57.2	36.9	0.65	3.80	70.1	15.0	7.7
				1800	73.2	4.70	57.2	107.7	4.57	10.2	1800	59.3	40.1	0.68	4.05	73.1	14.6	8.1
	12.0	3.5	8.0	1500	73.2	4.78	56.9	115.2	4.49	11.3	1500	57.8	37.2	0.64	3.73	70.5	15.5	7.1
				1800	75.0	4.73	58.8	108.6	4.64	10.5	1800	59.9	40.4	0.68	3.96	73.4	15.1	7.7
16.0	5.5	12.7	1500	75.5	4.84	59.0	116.6	4.57	11.7	1500	58.3	37.6	0.64	3.66	70.8	15.9	6.6	
				1800	77.4	4.78	61.0	109.8	4.74	10.8	1800	60.5	40.9	0.68	3.90	73.8	15.5	7.4
90	8.0	1.5	3.4	1500	76.3	4.92	59.5	117.1	4.55	12.4	1500	55.3	35.5	0.64	4.14	69.4	13.4	9.6
				1800	78.2	4.85	61.6	110.2	4.73	11.4	1800	57.7	38.6	0.67	4.41	72.8	13.1	10.2
	12.0	3.4	7.7	1500	77.3	4.97	60.4	117.7	4.56	12.7	1500	55.9	35.8	0.64	4.06	69.8	13.8	9.0
				1800	79.3	4.87	62.7	110.8	4.77	11.8	1800	58.3	38.9	0.67	4.32	73.0	13.5	9.7
16.0	5.3	12.2	1500	80.0	5.03	62.8	119.4	4.66	13.1	1500	57.8	37.1	0.64	4.11	71.8	14.1	8.3	
				1800	82.1	4.92	65.3	112.2	4.89	12.2	1800	58.9	39.3	0.67	4.25	73.4	13.9	9.2
100	8.0	1.4	3.3	Operation not recommended							Operation not recommended							
	12.0	3.2	7.5	1500	52.3	34.6	0.66	4.53	67.7	11.5	11.1	Operation not recommended						
				1800	54.8	37.6	0.69	4.83	71.2	11.3	12.1	Operation not recommended						
16.0	5.1	11.8	1500	52.8	35.0	0.66	4.45	68.0	11.9	10.3	Operation not recommended							
				1800	55.3	38.0	0.69	4.75	71.5	11.6	11.5	Operation not recommended						
110	8.0	1.4	3.2	Operation not recommended							Operation not recommended							
	12.0	3.1	7.2	1500	48.6	33.4	0.69	5.01	65.7	9.7	13.6	Operation not recommended						
				1800	51.2	36.3	0.71	5.34	69.5	9.6	14.8	Operation not recommended						
	16.0	4.9	11.4	1500	49.1	33.8	0.69	4.92	65.9	10.0	12.7	Operation not recommended						
				1800	51.7	36.7	0.71	5.25	69.6	9.8	14.1	Operation not recommended						
120	8.0	1.3	3.0	Operation not recommended							Operation not recommended							
	12.0	3.0	6.9	1500	46.8	31.0	0.66	5.55	65.7	8.4	16.5	Operation not recommended						
				1800	47.6	33.7	0.71	5.69	67.1	8.4	17.9	Operation not recommended						
	16.0	4.7	10.9	1500	47.2	31.0	0.66	5.37	65.5	8.8	15.3	Operation not recommended						
				1800	48.2	33.7	0.70	5.54	67.1	8.7	17.0	Operation not recommended						

Multiple Flow Rates (for EWT) are shown in the table above. The lowest flow rate shown is used for geothermal open loop/well water systems with a minimum 50° F. The second flow rate shown is the minimum geothermal closed loop flow rate. The third flow rate shown is optimum for geothermal closed loop and the suggested flow rate for boiler tower applications.

072 - Performance Data

072 - Dual Capacity Low Speed

EWT °F	Flow gpm	WPD		HEATING - EAT 70°F							COOLING - EAT 80/67 °F							
		PSI	FT	Airflow cfm	HC Mbtu/h	Power kW	HE Mbtu/h	LAT °F	COP	HWC Mbtu/h	Airflow cfm	TC Mbtu/h	SC Mbtu/h	S/T Ratio	Power kW	HR Mbtu/h	EER	HWC Mbtu/h
20	10.0	2.5	5.7	Operation not recommended							Operation not recommended							
	13.0	4.1	9.5	Operation not recommended							Operation not recommended							
	16.0	5.7	13.2	1400	35.8	3.77	22.9	93.7	2.78	6.0	Operation not recommended							
				1600	36.2	3.71	23.5	90.9	2.86	5.4	Operation not recommended							
30	10.0	2.4	5.6	Operation not recommended							Operation not recommended							
	13.0	4.0	9.2	1400	38.8	3.84	25.7	95.6	2.96	6.1	1400	50.6	30.1	0.60	1.76	56.6	28.8	-
				1600	40.7	3.89	27.4	93.6	3.07	5.6	1600	51.4	32.9	0.64	1.85	57.7	27.8	-
	16.0	5.6	12.8	1400	41.9	3.95	28.4	97.7	3.11	6.3	1400	50.9	30.1	0.59	1.70	56.7	29.8	-
				1600	42.4	3.89	29.1	94.5	3.19	5.7	1600	52.1	32.9	0.63	1.79	58.2	29.1	-
40	10.0	2.3	5.4	Operation not recommended							Operation not recommended							
	13.0	3.9	8.9	1400	44.9	4.00	31.2	99.7	3.29	6.5	1400	54.4	33.4	0.61	1.98	61.2	27.5	-
				1600	46.8	4.01	33.1	97.1	3.42	5.9	1600	55.4	36.5	0.66	2.08	62.5	26.7	-
	16.0	5.4	12.5	1400	46.4	4.01	32.7	100.7	3.39	6.7	1400	54.8	33.4	0.61	1.92	61.4	28.5	-
				1600	48.5	4.03	34.8	98.1	3.53	6.1	1600	56.1	36.5	0.65	2.01	62.9	27.9	-
50	10.0	2.3	5.2	1400	50.1	4.12	36.1	103.2	3.57	6.8	1400	57.9	35.0	0.60	2.25	64.6	25.8	2.3
				1600	52.4	4.07	38.5	100.3	3.77	6.3	1600	59.7	39.7	0.66	2.36	66.8	25.2	2.4
	13.0	3.7	8.6	1400	50.9	4.16	36.7	103.7	3.59	7.0	1400	58.1	35.3	0.61	2.17	65.5	26.7	2.1
				1600	52.9	4.14	38.8	100.6	3.75	6.4	1600	59.9	40.1	0.67	2.29	67.3	26.2	2.3
	16.0	5.2	12.1	1400	52.4	4.18	38.1	104.6	3.67	7.2	1400	58.2	35.3	0.61	2.11	66.0	27.5	2.0
				1600	54.6	4.16	40.4	101.6	3.85	6.6	1600	60.0	40.1	0.67	2.23	67.6	26.9	2.2
60	10.0	2.2	5.1	1400	55.5	4.24	41.0	106.7	3.83	7.5	1400	55.2	34.3	0.62	2.60	63.7	21.2	3.2
				1600	57.8	4.16	43.7	103.5	4.08	6.9	1600	56.9	38.7	0.68	2.72	65.8	20.9	3.4
	13.0	3.6	8.4	1400	57.1	4.29	42.4	107.7	3.90	7.7	1400	55.4	34.6	0.62	2.52	64.0	22.0	3.0
				1600	59.3	4.21	44.9	104.3	4.13	7.1	1600	57.1	39.1	0.69	2.63	66.1	21.7	3.2
	16.0	5.1	11.7	1400	58.4	4.33	43.6	108.6	3.95	7.9	1400	55.7	34.7	0.62	2.47	64.4	22.5	2.8
				1600	60.7	4.26	46.2	105.1	4.18	7.3	1600	57.4	39.2	0.68	2.58	66.2	22.3	3.1
70	10.0	2.1	4.9	1400	60.9	4.37	46.0	110.3	4.08	8.3	1400	52.5	33.5	0.64	2.96	62.3	17.8	4.5
				1600	64.5	4.33	49.7	107.3	4.37	7.7	1600	54.0	37.7	0.70	3.07	64.1	17.6	4.8
	13.0	3.5	8.1	1400	63.2	4.41	48.1	111.8	4.19	8.5	1400	52.8	33.9	0.64	2.86	62.6	18.5	4.2
				1600	65.6	4.29	51.0	108.0	4.49	7.9	1600	54.3	38.2	0.70	2.98	64.5	18.3	4.5
	16.0	4.9	11.3	1400	64.3	4.48	49.0	112.5	4.21	8.8	1400	53.1	34.1	0.64	2.82	62.8	18.8	3.9
				1600	66.8	4.35	52.0	108.7	4.50	8.1	1600	54.8	38.3	0.70	2.92	64.8	18.8	4.3
80	10.0	2.0	4.7	1400	65.4	4.49	50.1	113.3	4.27	9.2	1400	48.2	32.1	0.67	3.35	59.7	14.4	6.2
				1600	67.8	4.33	53.0	109.2	4.59	8.5	1600	51.2	35.9	0.70	3.45	63.0	14.9	6.6
	13.0	3.4	7.8	1400	68.9	4.55	53.3	115.5	4.44	9.5	1400	50.1	32.5	0.65	3.27	61.3	15.3	5.8
				1600	71.3	4.36	56.4	111.3	4.79	8.8	1600	51.6	36.3	0.70	3.36	63.1	15.4	6.3
	16.0	4.7	10.9	1400	69.7	4.61	53.9	116.1	4.43	9.8	1400	50.5	32.7	0.65	3.22	61.5	15.7	5.4
				1600	72.1	4.44	56.9	111.7	4.76	9.1	1600	50.5	36.6	0.72	3.31	61.8	15.3	6.0
90	10.0	2.0	4.6	1400	70.0	4.62	54.2	116.3	4.44	10.3	1400	43.9	30.7	0.70	3.75	56.7	11.7	8.3
				1600	72.3	4.42	57.2	111.8	4.79	9.5	1600	45.3	34.1	0.75	3.83	58.3	11.8	8.8
	13.0	3.3	7.5	1400	74.5	4.68	58.5	119.3	4.67	10.6	1400	44.4	31.0	0.70	3.67	57.7	12.1	7.7
				1600	77.0	4.44	61.8	114.6	5.08	9.8	1600	45.7	34.5	0.75	3.75	58.5	12.2	8.4
	16.0	4.6	10.5	1400	75.0	4.74	58.8	119.6	4.63	11.0	1400	46.8	33.2	0.71	3.73	59.5	12.5	7.2
				1600	77.3	4.53	61.8	114.7	5.00	10.2	1600	46.2	34.8	0.75	3.69	58.8	12.5	8.0
100	10.0	1.9	4.4	Operation not recommended							Operation not recommended							
	13.0	3.1	7.3	1400	41.9	29.6	0.71	4.30	56.5	9.7	10.0							
				1600	43.2	32.7	0.76	4.35	58.1	9.9	10.9							
	16.0	4.4	10.1	1400	42.4	29.9	0.70	4.23	56.9	10.0	9.3							
				1600	43.7	33.1	0.76	4.29	58.3	10.2	10.0							
110	10.0	1.8	4.2	Operation not recommended							Operation not recommended							
	13.0	3.0	7.0	1400	39.4	28.1	0.71	4.92	56.2	8.0	12.7							
				1600	40.7	31.0	0.76	4.95	57.6	8.2	13.8							
	16.0	4.2	9.8	1400	40.0	28.5	0.71	4.86	56.6	8.2	11.8							
				1600	41.2	31.4	0.76	4.88	57.9	8.4	13.1							
120	10.0	1.8	4.1	Operation not recommended							Operation not recommended							
	13.0	2.9	6.7	1400	37.5	28.1	0.75	5.49	56.2	6.8	15.8							
				1600	38.1	30.5	0.80	5.63	57.4	6.8	17.1							
	16.0	4.1	9.4	1400	37.8	28.1	0.74	5.31	55.9	7.1	14.6							
				1600	38.6	30.5	0.79	5.48	57.3	7.0	16.3							

Multiple Flow Rates (for EWT) are shown in the table above. The lowest flow rate shown is used for geothermal open loop/well water systems with a minimum 50° F. The second flow rate shown is the minimum geothermal closed loop flow rate. The third flow rate shown is optimum for geothermal closed loop and the suggested flow rate for boiler tower applications.

3/7/17

072 - Performance Data

072 - Dual Capacity High Speed

EWT °F	Flow gpm	WPD		HEATING - EAT 70°F						COOLING - EAT 80/67 °F								
		PSI	FT	Airflow cfm	HC Mbtu/h	Power kW	HE Mbtu/h	LAT °F	COP	HWC Mbtu/h	Airflow cfm	TC Mbtu/h	SC Mbtu/h	S/T Ratio	Power kW	HR Mbtu/h	EER	HWC Mbtu/h
20	12.0	3.4	7.9	Operation not recommended						Operation not recommended								
	15.0	5.1	11.9	Operation not recommended						Operation not recommended								
	18.0	7.0	16.1	1800	36.7	4.41	21.6	88.9	2.44	7.9	2000	37.0	4.43	21.9	87.1	2.45	7.1	
30	12.0	3.3	7.7	Operation not recommended						Operation not recommended								
	15.0	5.0	11.6	1800	54.7	4.80	38.3	98.1	3.34	8.3	1800	62.7	37.3	0.60	2.87	72.5	21.9	-
				2000	56.6	5.11	39.2	96.2	3.25	7.6	2000	63.8	40.8	0.64	3.02	74.1	21.1	-
	18.0	6.8	15.6	1800	56.7	5.14	39.2	99.2	3.23	8.6	1800	63.1	37.3	0.59	2.78	72.6	22.7	-
2000				57.2	5.16	39.6	96.5	3.25	7.8	2000	64.6	40.8	0.63	2.92	74.6	22.1	-	
40	12.0	3.2	7.5	Operation not recommended						Operation not recommended								
	15.0	4.8	11.2	1800	61.8	5.07	44.5	101.8	3.57	9.2	1800	67.5	41.4	0.61	3.17	78.3	21.3	-
				2000	63.9	5.30	45.8	99.6	3.53	8.4	2000	68.7	45.2	0.66	3.32	80.1	20.7	-
	18.0	6.6	15.2	1800	62.6	5.12	45.2	102.2	3.58	9.5	1800	68.0	41.4	0.61	3.07	78.5	22.1	-
2000				64.8	5.36	46.5	100.0	3.55	8.6	2000	69.5	45.2	0.65	3.22	80.5	21.6	-	
50	12.0	3.1	7.2	1800	65.2	5.22	47.4	103.5	3.66	9.9	1800	71.5	44.7	0.63	3.43	83.2	20.9	4.3
				2000	67.4	5.41	48.9	101.2	3.65	9.2	2000	73.0	48.6	0.67	3.64	85.4	20.1	4.6
	15.0	4.7	10.9	1800	68.9	5.32	50.7	105.4	3.79	10.3	1800	72.2	45.2	0.63	3.35	83.7	21.5	4.0
				2000	71.1	5.50	52.4	102.9	3.79	9.4	2000	73.6	49.1	0.67	3.57	85.8	20.7	4.4
	18.0	6.4	14.7	1800	70.1	5.39	51.7	106.1	3.81	10.6	1800	73.0	46.1	0.63	3.30	84.2	22.1	3.7
				2000	72.4	5.55	53.5	103.5	3.82	9.7	2000	74.4	49.6	0.67	3.51	86.4	21.2	4.2
60	12.0	3.0	7.0	1800	74.1	5.46	55.5	108.1	3.98	11.1	1800	67.7	43.8	0.65	3.74	80.4	18.1	5.3
				2000	76.5	5.57	57.5	105.4	4.03	10.3	2000	69.1	47.3	0.68	3.98	82.6	17.4	5.6
	15.0	4.5	10.5	1800	77.3	5.55	58.4	109.8	4.08	11.5	1800	68.3	44.2	0.65	3.67	80.8	18.6	4.9
				2000	79.9	5.64	60.6	107.0	4.15	10.6	2000	69.7	47.8	0.69	3.89	83.0	17.9	5.3
	18.0	6.2	14.2	1800	79.1	5.62	59.9	110.7	4.13	11.8	1800	69.1	44.9	0.65	3.60	81.4	19.2	4.6
				2000	81.7	5.70	62.3	107.8	4.20	10.9	2000	70.5	48.3	0.69	3.84	83.5	18.4	5.1
70	12.0	2.9	6.8	1800	82.9	5.68	63.5	112.7	4.28	12.5	1800	63.8	42.8	0.67	4.06	77.7	15.7	6.6
				2000	84.7	5.88	64.6	109.2	4.22	11.6	2000	65.2	46.0	0.71	4.32	79.9	15.1	7.0
	15.0	4.4	10.2	1800	85.9	5.77	66.2	114.2	4.36	12.9	1800	64.5	43.2	0.67	3.98	78.0	16.2	6.2
				2000	88.6	5.78	68.8	111.0	4.49	11.9	2000	65.8	46.5	0.71	4.22	80.2	15.6	6.7
	18.0	6.0	13.8	1800	88.1	5.85	68.1	115.3	4.42	13.3	1800	65.2	43.7	0.67	3.90	78.5	16.7	5.7
				2000	91.0	5.85	71.0	112.1	4.56	12.3	2000	66.5	47.0	0.71	4.16	80.7	16.0	6.4
80	12.0	2.8	6.5	1800	87.8	6.00	67.3	115.2	4.29	14.1	1800	60.6	40.9	0.67	4.52	76.0	13.4	8.4
				2000	91.1	6.03	70.5	112.2	4.43	13.0	2000	61.9	44.2	0.71	4.80	78.3	12.9	8.9
	15.0	4.3	9.8	1800	90.3	6.15	69.3	116.5	4.30	14.5	1800	61.2	41.3	0.67	4.42	76.3	13.8	7.8
				2000	93.2	6.07	72.5	113.1	4.50	13.4	2000	62.5	44.6	0.71	4.71	78.5	13.3	8.4
	18.0	5.7	13.3	1800	93.1	6.23	71.8	117.9	4.38	15.0	1800	61.9	41.9	0.68	4.35	76.7	14.2	7.2
				2000	96.1	6.14	75.2	114.5	4.59	13.8	2000	63.2	45.1	0.71	4.63	78.9	13.6	8.0
90	12.0	2.7	6.3	1800	93.5	6.46	71.4	118.1	4.24	15.8	1800	57.4	38.9	0.68	4.97	74.4	11.5	10.5
				2000	96.6	6.33	75.0	114.7	4.47	14.7	2000	58.6	42.3	0.72	5.29	76.7	11.1	11.1
	15.0	4.1	9.5	1800	94.8	6.53	72.5	118.8	4.25	16.3	1800	58.0	39.3	0.68	4.87	74.6	11.9	9.8
				2000	97.9	6.36	76.2	115.3	4.51	15.1	2000	59.2	42.7	0.72	5.19	76.9	11.4	10.6
	18.0	5.5	12.8	1800	98.0	6.62	75.5	120.4	4.34	16.8	1800	59.8	41.5	0.69	4.98	76.8	12.0	9.1
				2000	101.3	6.43	79.4	116.9	4.62	15.6	2000	59.8	43.1	0.72	5.10	77.2	11.7	10.1
100	12.0	2.6	6.1	Operation not recommended						Operation not recommended								
	15.0	4.0	9.1	1800	54.4	37.6	0.69	5.45	73.0	10.0	12.2							
				2000	55.5	40.7	0.73	5.80	75.3	9.6	13.2							
	18.0	5.3	12.3	1800	55.0	38.2	0.69	5.36	73.3	10.3	11.3							
2000				56.2	41.1	0.73	5.70	75.6	9.9	12.5								
110	12.0	2.5	5.8	Operation not recommended						Operation not recommended								
	15.0	3.8	8.8	Operation not recommended						1800	50.9	36.0	0.71	6.03	71.4	8.4	14.9	
				2000	51.9	38.7	0.75	6.41	73.8	8.1	16.1							
	18.0	5.1	11.9	Operation not recommended						1800	51.4	36.4	0.71	5.92	71.7	8.7	13.8	
2000				52.5	39.1	0.74	6.30	74.0	8.3	15.3								
120	12.0	2.4	5.6	Operation not recommended						Operation not recommended								
	15.0	3.7	8.4	Operation not recommended						1800	48.5	36.8	0.76	6.95	72.3	7.0	18.0	
				2000	49.4	39.9	0.81	7.13	73.8	6.9	19.5							
	18.0	4.9	11.4	Operation not recommended						1800	49.0	36.8	0.75	6.73	71.9	7.3	16.7	
2000				50.0	39.9	0.80	6.94	73.7	7.2	18.5								

Multiple Flow Rates (for EWT) are shown in the table above. The lowest flow rate shown is used for geothermal open loop/well water systems with a minimum 50° F. The second flow rate shown is the minimum geothermal closed loop flow rate. The third flow rate shown is optimum for geothermal closed loop and the suggested flow rate for boiler tower applications.

3/7/17

Wiring Schematics

Split Wiring Schematic - 208-230/60/1

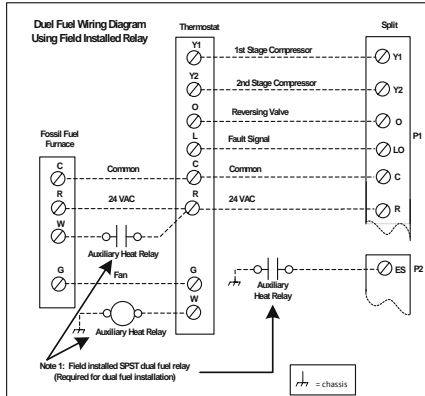
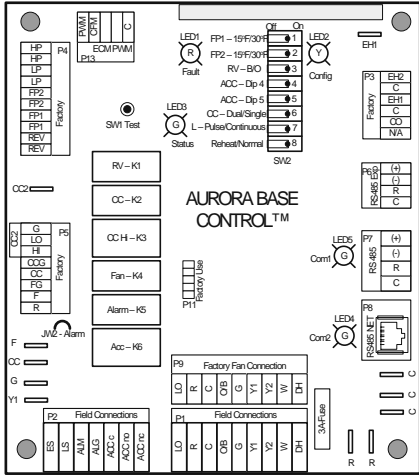

Notes
1 - Field installed SPST relay required for dual fuel applications

Legend

- Factory Low voltage wiring
- Factory Line voltage wiring
- Field low voltage wiring
- Field line voltage wiring
- Optional block
- DC Voltage PCB traces
- Junction
- Quick connect terminal
- Wire nut
- Field wire lug
- Ground
- Relay Contacts- N.O., N.C.
- Fuse
- Breaker
- Thermostat
- Light emitting diode - Green
- Relay coil
- Capacitor w/ bleed resistor
- Switch - Condensate overflow
- Switch - High pressure
- Switch - Low pressure
- Polarized connector
- Current Transducer (CT)

CC - Compressor Contactor
 CO - Condensate overflow sensor
 KS - DHW pump relay
 K6 - Loop pump relay
 CR3 - PSC Fan Speed Relay
 CR4 - PSC Fan Power Relay
 CS - Compressor Solenoid
 F1 and F2 - Fuses
 HE - Heater element
 HP - High pressure switch
 FP1 - Freeze protection sensor
 LP - Low pressure switch
 FB1, FB2 - Power block
 PS - Power strip
 RV - Reversing Valve coil
 SW1 - DIP package 5 position AxB
 SW2 - TEST MODE ABC Board
 DIP package 8 position ABC Board
 TS - Thermal limit switch
 HML - Hot water limit sensor
 SC - Start Contactor
 SR - Start Relay
 WCL - Water Coil Limit Sensor

Aurora Timing Events

Event	Normal Mode	Test Mode
Random Start Delay	5 to 80 seconds	1 second
Compressor On Delay	5 seconds	< 1 second
Compressor Minimum On Time	2 minutes	5 seconds
Compressor Short Cycle Delay	4 minutes	15 seconds
Blower Off Delay	30 seconds	2 seconds
Fault Recognition Delay - High Pressure	Less than 1 second	Less than 1 second
Start-Up Bypass - Low Pressure	2 minutes	30 seconds
Fault Recognition Delay - Low Pressure	30 seconds	30 seconds
Start-Up Bypass - Low Water Coil Limit	2 minutes	30 seconds
Fault Recognition Delay - Low Water Coil Limit	30 seconds	30 seconds
Fault Recognition Delay - Condensate Overflow	30 seconds	30 seconds
Thermostat Call Recognition Time	2 seconds	2 seconds
Water Valve Slow Open Delay	90 seconds	90 seconds

ABC SW2 Accessory Relay

DESCRIPTION	SW2-4	SW2-5
Cycle with Blower	ON	ON
Cycle with Compressor	OFF	OFF
Water Valve Slow Opening	ON	OFF
Cycle with Comm. T-stat Hum Cmd	OFF	ON

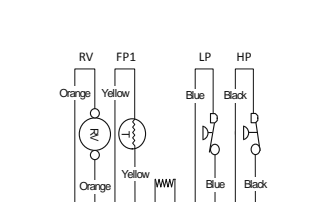
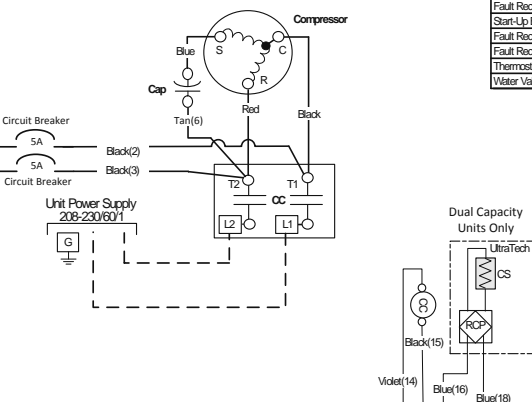
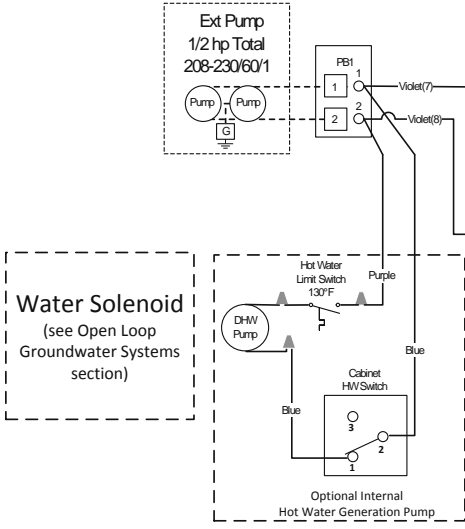

Aurora LED Flash Codes

Flash Code	Configuration	LED Color
Slow Flash	1 second on and 1 second off	Green
Fast Flash	100 milliseconds on and 100 milliseconds off	Green
Flash Code	100 milliseconds on and 400 milliseconds off with a 2 second pause before repeating	Green
Random Start Delay (Alternating Colors)	Configuration	LED2, Yellow
Status LED (LED1, Green)	Fast Flash	No Software Override
Configuration LED (LED2, Yellow)	Fast Flash	DIP Switch Override
Fault LED (LED3, Red)	Fast Flash	
Fault LED (LED1, Red)	Fast Flash	
Normal Mode	OFF	Normal Mode
Input Fault Lockout	Flash Code 1	Control is Non-Functional
High Pressure Lockout	Flash Code 2	Test Mode
Low Pressure Lockout	Flash Code 3	Lockout Active
Future Use	Flash Code 4	Dehumidification Mode
Freeze Detection - FP1	Flash Code 5	Future Use
Reserved	Flash Code 6	Future Use
Condensate Overflow Lockout	Flash Code 7	Load Shed
Over/Under Voltage Shutdown	Flash Code 8	ESD
Future Use	Flash Code 9	Future Use
Future Use	Flash Code 10	Future Use
FP1 and FP2 Sensor Error	Flash Code 11	

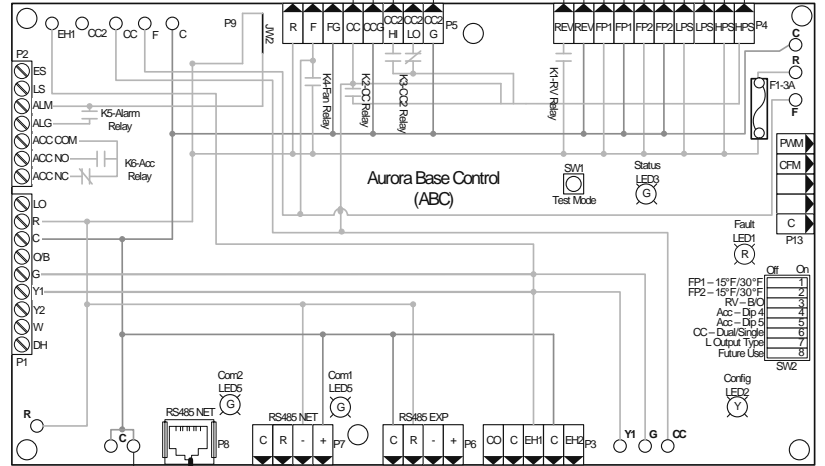

Wiring Schematics cont.

Split Wiring Schematic with IntelliStart - 208-230/60/1

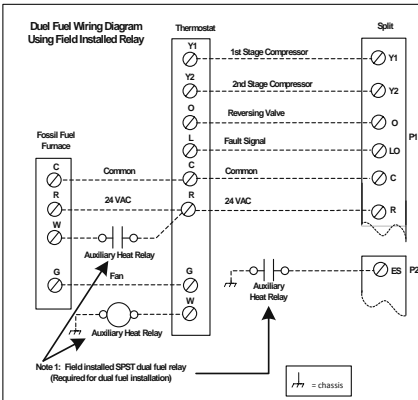
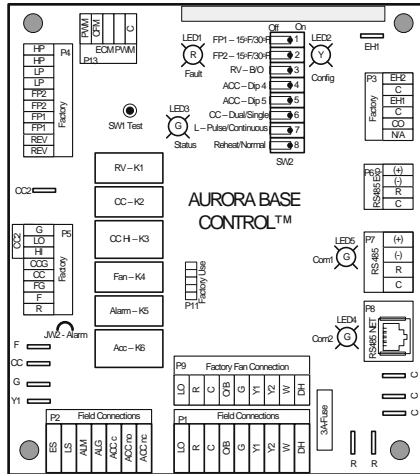

Legend

- Factory Low voltage wiring
- Factory Line voltage wiring
- Field low voltage wiring
- Field line voltage wiring
- Optional block
- DC Voltage PCB traces
- Junction
- Quick connect terminal
- Wire nut
- Field wire lug
- Ground
- Relay Contacts- N.O., N.C.
- Fuse
- Breaker
- Thermostat
- Light emitting diode - Green
- Relay coil
- Capacitor w/ bleed resistor
- Switch - Condensate overflow
- Switch - High pressure
- Switch - Low pressure
- Polarized connector
- Current Transducer (CT)

CC - Compressor Contactor
 CO - Condensate overflow sensor
 KS - DHW pump relay
 KB - Loop pump relay
 CR3 - PSC Fan Speed Relay
 CR4 - PSC Fan Power Relay
 CS - Compressor Solenoid
 F1 and F2 - Fuses
 HE - Heater element
 HP - High pressure switch
 FP1 - Freeze protection sensor
 LP - Low pressure switch

PB1, PB2 - Power blocks
 PS - Power strip
 RV - Reversing Valve coil
 SW1 - DIP package 5 position AXB
 SW2 - TEST MODE ABC Board
 SW2 - DIP package 8 position ABC Board

TS - Thermal limit switch
 HML - Hot water limit switch
 SC - Start Contactor
 SR - Start Relay
 WCL - Water Coil Limit Sensor

Notes

1 - Field installed SPST relay required for dual fuel applications

Water Solenoid
(see Open Loop Groundwater Systems section)

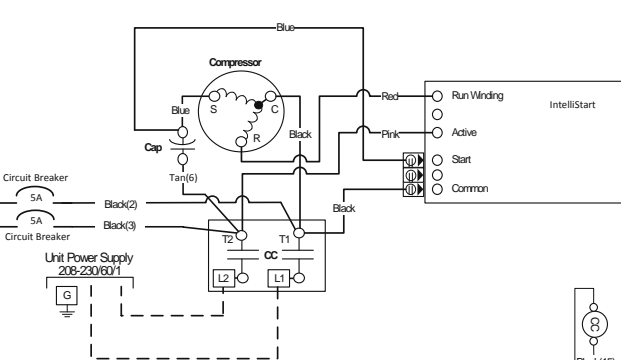
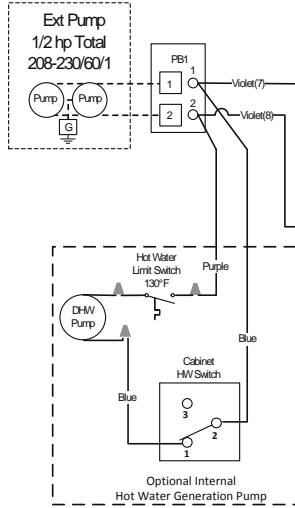

Aurora Timing Events

Event	Normal Mode	Test Mode
Random Start Delay	5 to 80 seconds	1 second
Compressor On Delay	5 seconds	< 1 second
Compressor Minimum On Time	2 minutes	5 seconds
Compressor Short Cycle Delay	4 minutes	15 seconds
Blower Off Delay	30 seconds	2 seconds
Fault Recognition Delay - High Pressure	Less than 1 second	Less than 1 second
Start-Up Bypass - Low Pressure	2 minutes	30 seconds
Fault Recognition Delay - Low Pressure	30 seconds	30 seconds
Start-Up Bypass - Low Water Coil Limit	2 minutes	30 seconds
Fault Recognition Delay - Low Water Coil Limit	30 seconds	30 seconds
Fault Recognition Delay - Condensate Overflow	30 seconds	30 seconds
Thermostat Call Recognition Time	2 seconds	2 seconds
Water Valve Slow Open Delay	90 seconds	90 seconds

ABC SW2 Accessory Relay

DESCRIPTION	SW2-4	SW2-5
Cycle with Blower	ON	ON
Cycle with Compressor	OFF	OFF
Water Valve Slow Opening	ON	OFF
Cycle with Comm. T-stat Hum Cmd	OFF	ON

Aurora LED Flash Codes

Flash Code	Description
Slow Flash	1 second on and 1 second off
Fast Flash	100 milliseconds on and 100 milliseconds off
Flash Code	100 milliseconds on and 400 milliseconds off with a 2 second pause before repeating
Random Start Delay (Alternating Colors)	Configuration LED (LED2, Yellow)
Status LED (LED1, Green)	Fast Flash: No Software Override; OFF: OFF
Configuration LED (LED2, Yellow)	Fast Flash: DIP Switch Override; Slow Flash: Slow Flash
Fault LED (LED3, Red)	Fast Flash: Fault
Fault LED (LED1, Red)	Status LED (LED3, Green)
Normal Mode	OFF
Input Fault Lockout	Flash Code 1: Control is Non-Functional; OFF: OFF
High Pressure Lockout	Flash Code 2: Test Mode; Slow Flash: Slow Flash
Low Pressure Lockout	Flash Code 3: Lockout Active; Fast Flash: Fast Flash
Future Use	Flash Code 4: Dehumidification Mode; Flash Code 2: Flash Code 2
Freeze Detection - FP1	Flash Code 5: Future Use; Flash Code 3: Flash Code 3
Reserved	Flash Code 6: Future Use; Flash Code 4: Flash Code 4
Condensate Overflow Lockout	Flash Code 7: Load Shed; Flash Code 5: Flash Code 5
Over/Under Voltage Shutdown	Flash Code 8: Future Use; Flash Code 6: Flash Code 6
Future Use	Flash Code 9: Future Use; Flash Code 7: Flash Code 7
Future Use	Flash Code 10: Future Use; Flash Code 8: Flash Code 8
FP1 and FP2 Sensor Error	Flash Code 11: Future Use; Flash Code 9: Flash Code 9

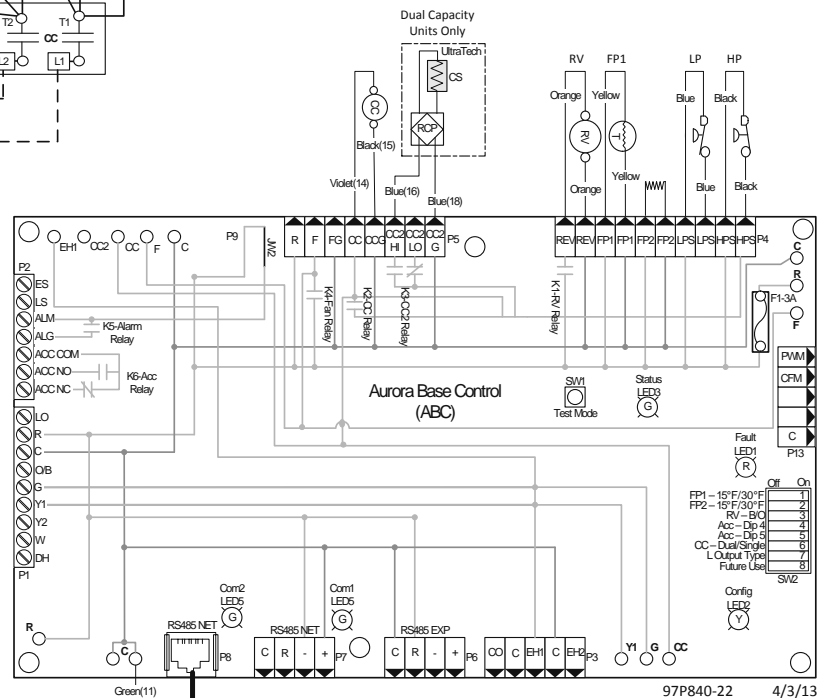

Wiring Schematics cont.

Aurora Advanced Controls

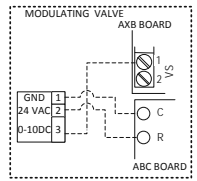
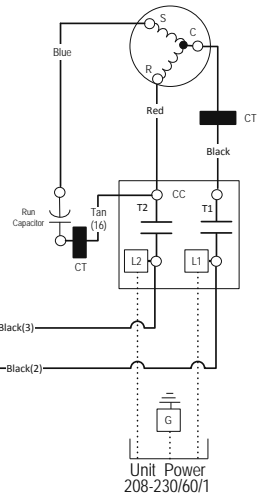
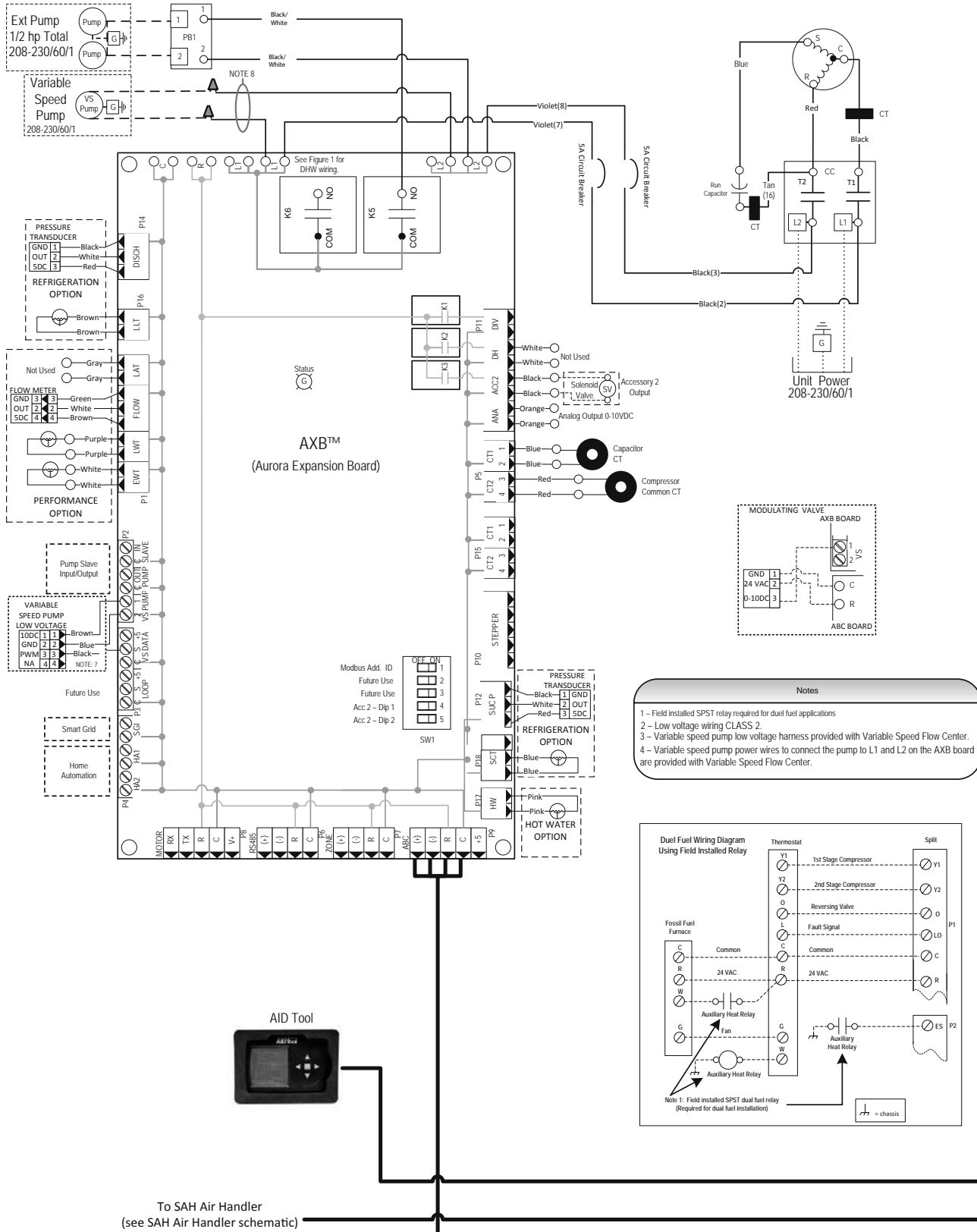

- Notes**
- 1 - Field installed SPST relay required for dual fuel applications
 - 2 - Low voltage wiring CLASS 2.
 - 3 - Variable speed pump low voltage harness provided with Variable Speed Flow Center.
 - 4 - Variable speed pump power wires to connect the pump to L1 and L2 on the AXB board are provided with Variable Speed Flow Center.

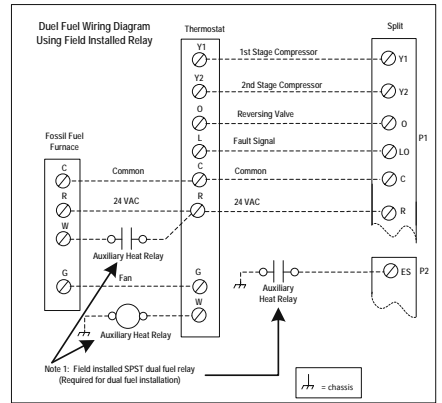

To SAH Air Handler
(see SAH Air Handler schematic)

Wiring Schematics cont.

Aurora Advanced Controls

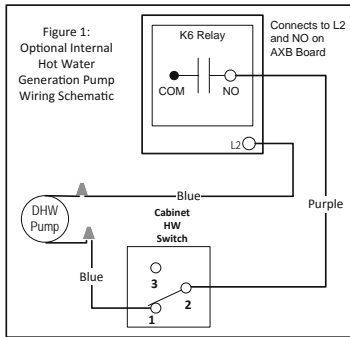
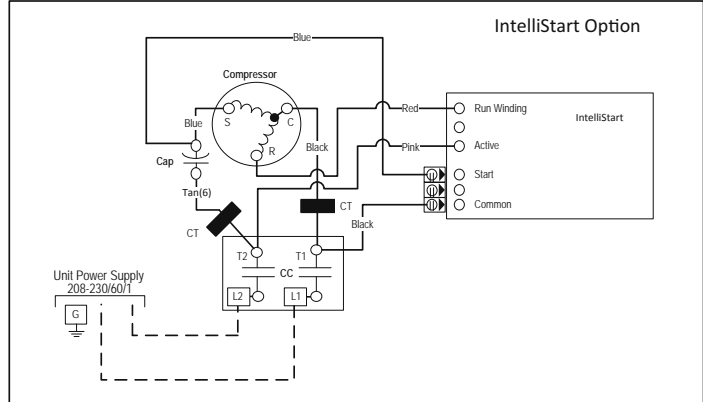
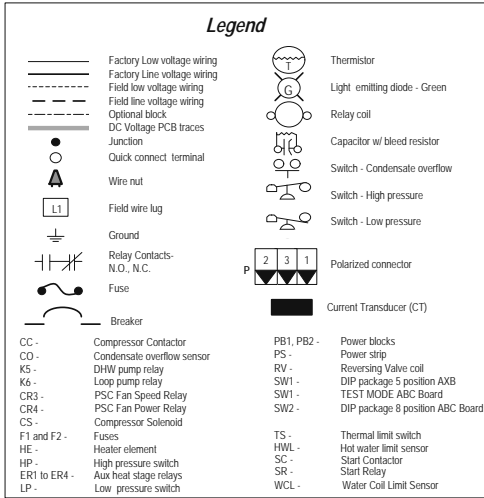

Aurora LED Flash Codes			
Slow Flash 1 second on and 1 second off			
Fast Flash 100 milliseconds on and 100 milliseconds off			
Flash Code 100 milliseconds on and 400 milliseconds off with a 2 second pause before repeating			
Random Start Delay (Alternating Colors)		Configuration LED (LED2, Yellow)	
Status LED (LED1, Green)	Fast Flash	No Software Override	OFF
Configuration LED (LED2, Yellow)	Fast Flash	DIP Switch Override	Slow Flash
Fault LED (LED3, Red)	Fast Flash		
Fault LED (LED1, Red)		Status LED (LED3, Green)	
Normal Mode	OFF	Normal Mode	ON
Input Fault Lockout	Flash Code 1	Control is Non-Functional	OFF
High Pressure Lockout	Flash Code 2	Test Mode	Slow Flash
Low Pressure Lockout	Flash Code 3	Lockout Active	Fast Flash
Future Use	Flash Code 4	Dehumidification Mode	Flash Code 2
Freeze Detection - FP1	Flash Code 5	Future Use	Flash Code 3
Reserved	Flash Code 6	Future Use	Flash Code 4
Condensate Overflow Lockout	Flash Code 7	Load Shed	Flash Code 5
Over/Under Voltage Shutdown	Flash Code 8	ESD	Flash Code 6
Future Use	Flash Code 9	Future Use	Flash Code 7
Future Use	Flash Code 10		
FP1 and FP2 Sensor Error	Flash Code 11		

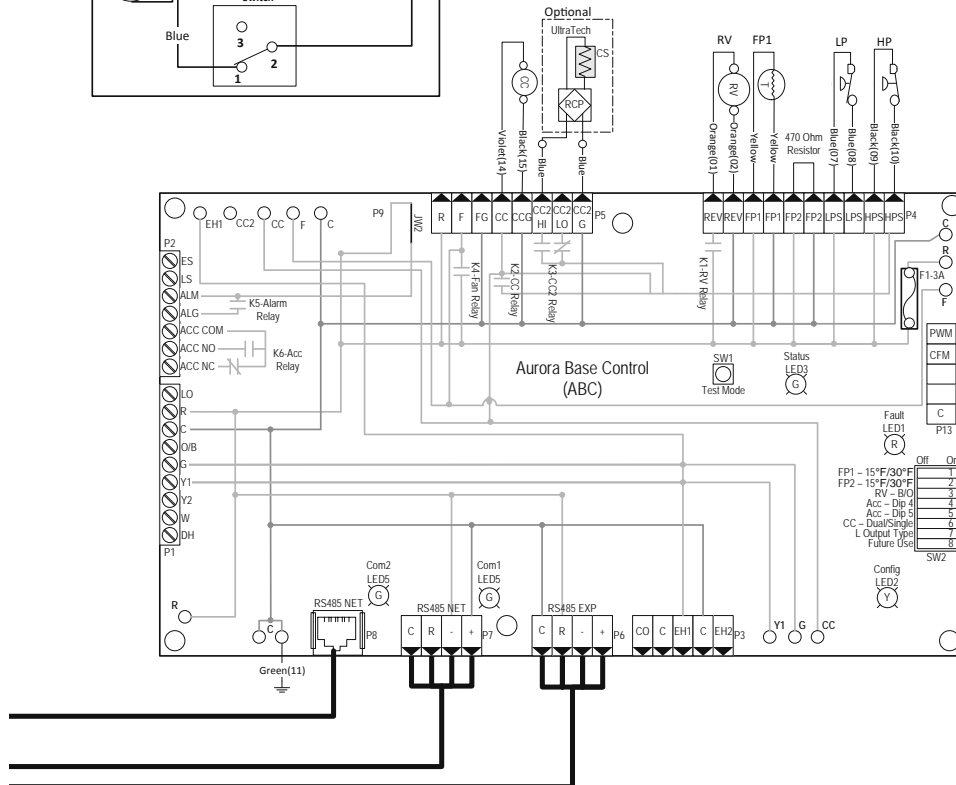

Engineering Guide Specifications

General

Furnish and install Water Source Heat Pumps, as indicated on the plans. The geothermal heating/cooling units shall be reverse cycle split system configuration designed for use with DX heating and cooling coils. Units shall be AHRI/ISO 13256-1 certified and listed by a nationally recognized safety-testing laboratory or agency, such as ETL Testing Laboratory. Each unit shall be computer run-tested at the factory with conditioned water and operation verified to catalog data. Each unit shall be mounted on a pallet and shipped in a corrugated box or stretch-wrapped. The units shall be designed to operate with entering liquid temperature between 20°F and 120°F [-6.7°C and 48.9°C].

Casing and Cabinet

The cabinet shall be fabricated from heavy-gauge galvanized steel and finished with corrosion-resistant powder coating. This corrosion protection system shall meet the stringent 1000 hour salt spray test per ASTM B117. The interior shall be insulated with 1/2-inch thick, multi-density, cleanable aluminum foil coated glass fiber with edges sealed or tucked under flanges. Standard cabinet panel insulation must meet NFPA 90A requirements, air erosion and mold growth limits of UL-181, stringent fungal resistance test per ASTM-C1071 and ASTM G21, and shall meet zero level bacteria growth per ASTM G22. Unit insulation must meet these stringent requirements or unit(s) will not be accepted.

Refrigerant Circuit

All units shall contain a sealed refrigerant circuit including a hermetic motor-compressor, thermostatic expansion valve, reversing valve, coaxial tube water-to-refrigerant heat exchanger, compressor discharge muffler, accumulator, and service ports.

Compressors shall be high-efficiency scroll single speed or dual capacity type designed for heat pump duty and mounted on rubber vibration isolators. Compressor motors shall be single-phase PSC with overload protection.

The coaxial water-to-refrigerant heat exchanger shall be designed for low water pressure drop and constructed of a convoluted copper (cupronickel option) inner tube and a steel outer tube. Refrigerant to water heat exchangers shall be of copper inner water tube and steel refrigerant outer tube design, rated to withstand 600 psig (4135 kPa) working refrigerant pressure and 450 psig (3101 kPa) working water pressure. The thermostatic expansion valve shall provide proper superheat over the entire liquid temperature range with minimal "hunting."

All units shall have the source coaxial tube refrigerant-to-water heat exchanger and the optional hot water generator coil coated with ThermaShield. Refrigerant suction lines shall be insulated to prevent condensation at low liquid temperatures.

Electrical

A control box shall be located within the unit compressor compartment and shall contain a 2 pole compressor contactor, circuit breakers for protecting loop pumps, terminal block for thermostat wiring, and solid-state controller for complete unit operation. Electromechanical operation WILL NOT be accepted. Units shall be name-plated for use with time delay fuses or HACR circuit breakers. Unit controls shall be 24 volt and provide heating or cooling as required by the remote thermostat/sensor. An Aurora, a microprocessor-based controller, interfaces with a multi-stage electronic thermostat to monitor and control unit operation shall be provided. The control shall provide operational sequencing, high and low pressure switch monitoring, freeze detection, hot water limit thermistor sensing, lockout mode control, hot water and loop pump control, LED status and fault indicators, fault memory, field selectable options, and accessory output. The Lockout signal output shall have a pulsed option so that DDC systems can read specific lockout conditions from the control.

A detachable terminal block with screw terminals will be provided for field control wiring. All units shall have knockouts for entrance of low and line voltage wiring. The control box shall be harness plug wired for easy removal.

An optional Aurora Interface Diagnostic (AID) Tool shall communicate with the Aurora control allowing quick and easy access to setup, monitoring, and troubleshooting of any Aurora control. The device shall include the features of fault description and history, manual operation capability, sensor readings, timings, and other diagnostic tools.

Optional IntelliStart® (compressor Soft Starter) shall be factory installed for use in applications that require low starting amps, reduced compressor start-up noise, off-grid, and improved start-up behavior. IntelliStart shall reduce normal starting current by 60% on 208/60/1 units.

Piping

Supply and return water connections shall be 1 in. [25.4 mm] FPT brass swivel fittings, which provide a union and eliminate the need for pipe wrenches and sealants when making field connections. The optional hot water generator shall have sweat type connections. All water piping shall be insulated to prevent condensation at low liquid temperatures.

Engineering Guide Specifications cont.

Options and Accessories

Cupronickel Heat Exchanger

An optional cupronickel water-to-refrigerant heat exchanger shall be provided.

Hot Water Generator

An optional ThermaShield coated heat reclaiming hot water generator coil of vented double-wall copper construction suitable for potable water shall be provided. The coil and hot water circulating pump shall be factory mounted inside the unit with integral electronic high limit temperature monitoring and external on/off switch.

Thermostat (field-installed)

A multi-stage auto-changeover electronic digital thermostat shall be provided. The thermostat shall offer three heating and two cooling stages with precise temperature control. An OFF-HEAT-AUTO-COOL-EMERG system switch, OFF-AUTO blower switch, and indicating LEDs shall be provided. The thermostat shall display in °F or °C. The thermostat shall be a traditional 24 VAC type.

Flow Center (field-installed)

A self-contained module shall provide all liquid flow, fill and connection requirements for ground source closed loop systems up to 20 gpm. The pumps shall be wired to a power block located in the nearest unit. The heat pump units shall contain low voltage pump slaving control so that two units may share one flow center.

Revision Guide

Pages:	Description:	Date:	By:
Misc.	Various Updates related to AHB release	15 Apr 2017	JM
All	First Published	09 Oct 2013	DS



Manufactured by
WaterFurnace International, Inc.
9000 Conservation Way
Fort Wayne, IN 46809
www.waterfurnace.com

