

# Rosemount™ Wireless Permasense ET210 Corrosion Transmitter



## NOTICE

This guide provides basic guidelines for the installation of the Rosemount Wireless Permasense ET210 Corrosion Transmitter. It does not provide instructions for configuration, diagnostics, maintenance, service, troubleshooting or intrinsically safe (I.S.) installations. Refer to the Rosemount Wireless Permasense ET210 Corrosion Transmitter Reference Manual for more instruction. The manual and this guide are also available electronically on [Emerson.com/Rosemount](http://Emerson.com/Rosemount).

### Shipping considerations

Each device contains two “D” size primary lithium-thionyl chloride battery cells. Primary lithium batteries are regulated in transportation by the U.S. Department of Transportation, and are also covered by IATA (International Air Transport Association), ICAO (International Civil Aviation Organization), and ARD (European Ground Transportation of Dangerous Goods). It is the responsibility of the shipper to ensure compliance with these or any other local requirements. Consult current regulations and requirements before shipping.

## ⚠ WARNING

### Explosion hazard

Explosions could result in death or serious injury.

Installation of this transmitter in an explosive environment must be in accordance with the appropriate local, national, and international standards, codes, and practices. Review the approvals section of this manual for any restrictions associated with a safe installation.

Before connecting a CC21 in an explosive atmosphere, make sure the instruments in the segment are installed in accordance with intrinsically safe or non-incendive field wiring practices.

### **This device complies with Part 15 of the FCC Rules. Operation is subject to the following conditions:**

This device may not cause harmful interference.

This device must accept any interference received, including interference that may cause undesired operation.

This device must be installed to ensure a minimum antenna separation distance of 8-in. (20 cm) from all persons.

### Electrostatic hazard

The power module may be replaced in a hazardous area. The power module has surface resistivity greater than one gigaohm and must be properly installed on the wireless device. Care must be taken during transportation to and from the point of installation to prevent a potential electrostatic charging hazard.

### **Polymer enclosure has surface resistivity greater than one gigaohm.**

Care must be taken during transportation to and from the point of installation to prevent a potential electrostatic charging hazard.

**⚠ WARNING**

**Physical access**

Unauthorized personnel may potentially cause significant damage to and/or misconfiguration of end users' equipment. This could be intentional or unintentional and needs to be protected against.

Physical security is an important part of any security program and fundamental to protecting your system. Restrict physical access by unauthorized personnel to protect end users' assets. This is true for all systems used within the facility.

---

---

**Contents**

Overview..... 5

Wireless considerations..... 7

Field communicator connections..... 8

Physical installation..... 9

Commissioning device..... 12

Product certifications..... 15



# 1 Overview

**Figure 1-1: Rosemount Wireless Permasense ET210 Corrosion Transmitter**

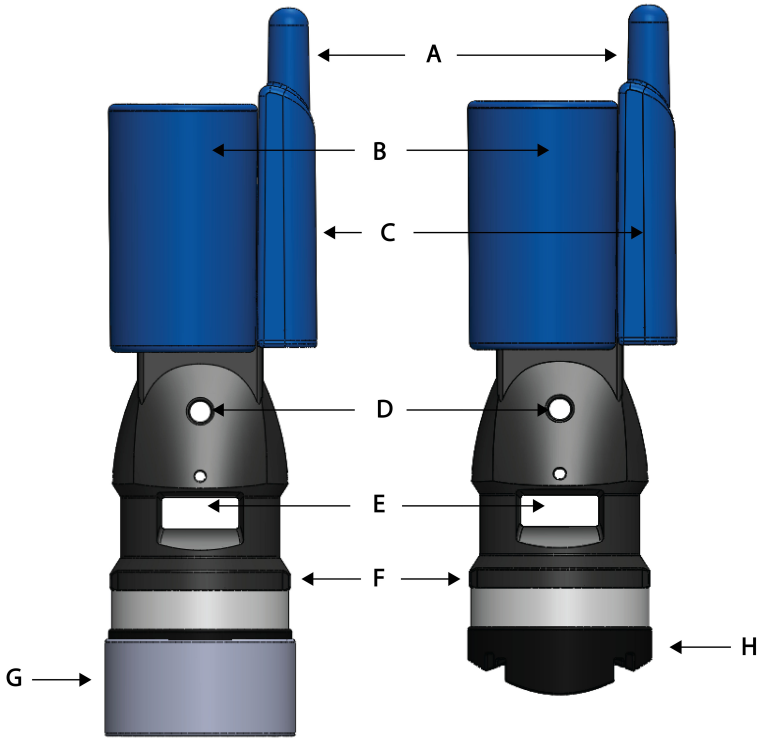

- A. Antenna
- B. Power module
- C. Head
- D. Lanyard hole
- E. Strap slot
- F. Foot
- G. Cap
- H. Shoe

## 1.1 Required equipment - IK220

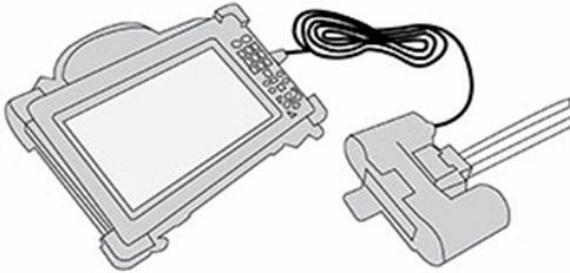

## 1.2 Required tooling

Tooling is supplied in the Permasense IK220 Installation Kit:

- Hex key, 2.5 mm, for power module retaining bolts
- Strap tightening tool - HCL SM-FT-2000

## 1.3 What's in the box

- Rosemount Wireless Permasense ET210 transmitter, complete with protective cap
- Lanyard kit, 316 stainless steel lanyard 6.5 ft. (2 m) in length, gripper No. 2, release key
- Silicone rubber shoe
- Strap kit, comprising polymer strap and buckle
- Rosemount Permasense BP20E power module
- M3 x 16 mm stainless steel retaining bolts, two per sensor

## 2 Wireless considerations

### Power up sequence

The Emerson Wireless Gateway should be installed and functioning properly before any wireless devices are powered. Commission the Rosemount Wireless Permasense ET210 and install the BP20E power module to power the device only (following instructions below) after the gateway has been installed and functioning. This results in a simpler and faster network installation. Enabling active advertising on the Gateway ensures new devices are able to join the network faster. For more information see the Emerson Wireless 1420 Gateway [Reference Manual](#) .

### Antenna position

The antenna is internal to the Rosemount Wireless Permasense ET210 transmitter. The antenna should also be approximately 3 ft. (1 m) from any large structure, building, or conductive surface to allow for clear communication to other devices.

### 3 Field communicator connections

The CC21 commissioning cable is connected and removed from the transmitter in the same way as the Rosemount BP20E power module. The USB connector is plugged in to the tablet PC as shown in [Figure 3-1](#).

**Figure 3-1: IK220 Commissioning Kit**

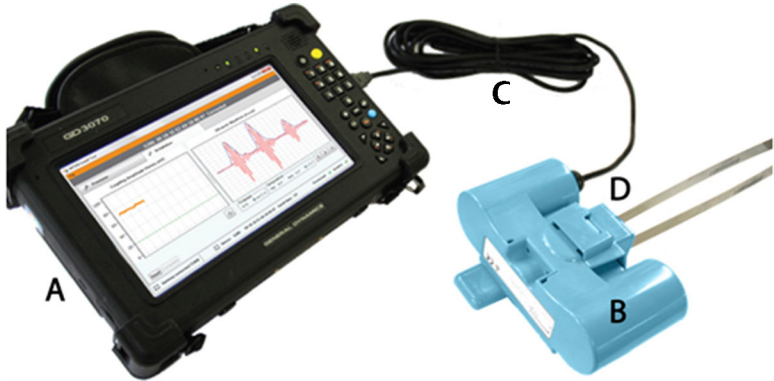

- A. Tablet PC
- B. CC21
- C. USB cable plugged into USB port
- D. Rosemount Wireless Permasense WT210/ET210 sensor



## 4 Physical installation

### 4.1 Mounting the sensor

#### Procedure

1. Identify the location where the sensor should be fixed. Clean the area where the sensor will touch the pipe, mainly to remove any particles which might keep the transducer away from the pipe surface or damage the face of the transducer. Use a permanent marker to show exactly where each sensor is to be placed.
2. Remove the protective cap from the sensor. Ensure tools and fastenings are kept away from the sensor when the cap is removed. Ensure the metal ring and the rubber shoe are fitted before installing the sensor. If either part is missing, do not proceed with the installation.

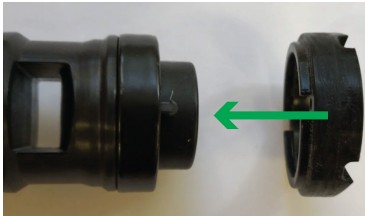

3. Place the sensor in the required location on the pipe.

#### **⚠ CAUTION**

The magnets used in the sensors have a high pull force. To avoid damage, and to get the precise location for each sensor, put the sensor at an angle to the pipe and then gently lower the shoe onto the pipe.



4. Cut the strap to a suitable length. This will depend on the diameter of the pipe. If the diameter of the pipe is  $D$  inches/cm, the length can be approximated by  $3 \times (D + 4)$  inches (or  $3 \times (D + 10)$  cm).
5. Attach a buckle to one end of the strap. Ensure the strap teeth are on the outside of the strap, and are fully engaged with the buckle.





---

### Note

A small flat screwdriver can be used to disengage the buckle, if required.

---

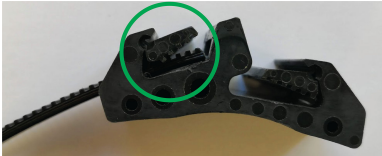
6. Slide the strap through the sensor(s), pass the strap through the buckle. Where possible, position the buckle opposite the middle sensor to ensure both sides of the strap are tightened evenly.



7. Tighten the strap by hand to gently hold the sensor in place. If necessary, adjust the position of the sensor to ensure correct alignment around the circumference of the pipe. With multiple sensors on a strap, there should be a gap between the shoes of adjacent sensors.
8. Prepare the lanyard kit and decide how it will be positioned. Wrap the lanyard around the circumference of the pipe. The 7 ft. (2 m) length will accommodate a maximum diameter of 24-in. (610 mm). When it is not possible to wrap the lanyard around a pipe, find an alternative attachment point for the lanyard.
9. Thread the bare end of the wire through the loop in the lanyard to secure it to the pipe.



10. Feed the bare end of the lanyard into the gripper and push the gripper 6-in. (15 cm) up from the bare end.
  11. Feed the bare end through the lanyard hole in each sensor and then into the return hole of the gripper.
- 

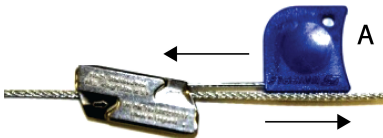

A. Release key

---

**Note**

The wire can be released from the gripper using the release key.

---

## 5 Commissioning device

### 5.1 Provisioning wireless network

For instructions on how to re-provision and reinstall the sensor, refer to the Rosemount Wireless Permasense ET210 Reference Manual.

#### Procedure

1. Power up the rugged tablet PC and connect the CC21.
2. Double-click the Rosemount ET210 installation app desktop icon. Within approximately 10 seconds, the Permasense installation tool software should open.
3. Attach the CC21 to the sensor.
4. In the Rosemount ET210 installation app software:
  - a) The sensor ID and MAC address of the sensor should be displayed at the top of the screen within 10 seconds.
  - b) Select the *Provision* tab.
  - c) Enter the five-digit network ID and the 32 hexadecimal (numbers 0-9 and letters A-F) join key.
  - d) Click the **Provision** button. Confirmation is given when provisioning is complete.
  - e) Check the network ID of the gateway is visible in the network discovery list.

---

#### Note

Joining the device to the network could take several minutes.

---

**Figure 5-1: Install Tool**

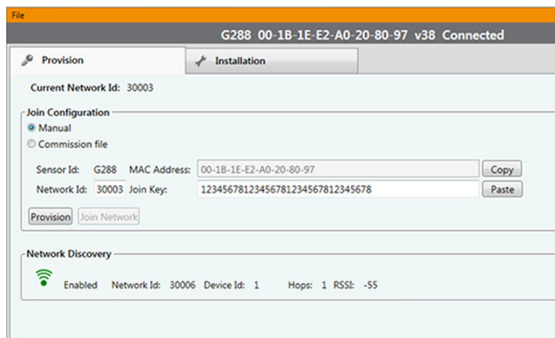

## 5.2 Completing sensor installation

Complete the following in the Rosemount ET210 installation app software on the Installation tab:

### Procedure

1. In the Rosemount WT210 installation app software, select the **Installation** tab.
2. Press the **Start** button. Wait for an Ultrasonic waveform to download from the sensor.

---

### Note

Waveforms are automatically downloaded every 10 seconds. When a new waveform arrives, the lines briefly become thicker.

---

3. Check the quality of the waveform. The first one or two reflections must be well defined above the noise in the signal. Only one reflection is needed to calculate a thickness. If the signal is poor, move the sensor to a slightly different position.
4. Ensure the measured thickness displayed meets expectations.
5. Tighten the strap using the tensioning tool provided so that the rubber shoe is compressed slightly and the sensor is held in place securely. On small diameter pipes the curved part of the shoe should touch the pipe. Overtightening the strap will deform the shoe and could damage the sensor.

---

### Note

For the same tension in the strap, more force is exerted on the shoe on smaller diameter pipes.



Correct strap tension

Strap too loose; shoe not compressed

Strap too tight; shoe too compressed

- 
6. Wait for a new waveform to display and check the ultrasonic waveform quality is still good after tightening the strap
  7. Cut off any unnecessary strap.

- 8. Press the **Complete** button. Verify that the *Install State* is **Off** and *Installed* is ticked in the footer of the application.

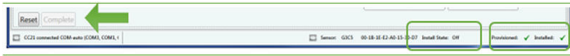

- 9. Remove the CC21 and fit the power module, tightening the two power module retaining bolts. When the power module is fitted, the sensor will restart and try to join the *WirelessHART*® gateway. In a large network of 100 sensors this can often take 2 hours, and sometimes up to 6 hours.

Sensor installation is complete.

## 6 Product certifications

Rev 0.1

### 6.1 European Directive information

A copy of the EU Declaration of Conformity can be found at the end of the Quick Start Guide. The most recent revision of the EU Declaration of Conformity can be found at [Emerson.com/Rosemount](https://www.emerson.com/Rosemount).

### 6.2 Telecommunications compliance

All wireless devices require certification to ensure they adhere to regulations regarding the use of the RF spectrum. Nearly every country requires this type of product certification.

Emerson is working with governmental agencies around the world to supply fully compliant products and remove the risk of violating country directives or laws governing wireless device usage.

### 6.3 FCC and IC

This device complies with Part 15 of the FCC Rules. Operation is subject to the following conditions: This device may not cause harmful interference; this device must accept any interference received, including interference that may cause undesired operation. This device must be installed to ensure a minimum antenna separation distance of 20 cm from all persons.

### 6.4 Ordinary location certification

As standard, the device has been examined and tested to determine that the design meets the basic electrical, mechanical, and fire protection requirements by a nationally recognized test laboratory (NRTL) as accredited by the Federal Occupational Safety and Health Administration (OSHA).

### 6.5 North America

The US National Electrical Code® (NEC) and the Canadian Electrical Code (CEC) permit the use of Division marked equipment in Zones and Zone marked equipment in Divisions. The markings must be suitable for the area classification, gas, and temperature class. This information is clearly defined in the respective codes.

### 6.6 USA

#### 6.6.1 I5 USA Intrinsically Safe (IS)

**Certificate:** SGSNA/17/SUW/00281

**Standards:** UL 913 - 8th Edition, Revision Dec 6 2013

**Markings:** CLASS I, DIV 1, GP ABCD, T4, Tamb = -50 °C to +75 °C, IP67

## 6.7 Canada

### 6.7.1 I6 Canada Intrinsically Safe (IS)

**Certificate:** SGSNA/17/SUW/00281

**Standards:** CAN/CSA C22.2 No. 157-92 (R2012) +UPD1 +UPD2

**Markings:** CLASS I, DIV 1, GP ABCD, T4, Tamb = -50 °C to +75 °C, IP67

## 6.8 Europe

### 6.8.1 I1 ATEX Intrinsically Safe (IS)

**Certificate:** Baseefa15ATEX0146X Issue 3

**Standards:** EN IEC 60079-0:2018

EN 60079-11: 2012

**Markings:**  I 1 G, Ex ia IIC T4 Ga, Tamb = -50 °C to +75 °C, IP67

#### Specific Conditions For Safe Use (X):

1. The plastic mounting foot may present a potential electrostatic ignition risk and must not be rubbed or cleaned with a dry cloth.
2. When fitted with the appropriate high-temperature mounting foot, the equipment may be attached to process pipework at a temperature of up to 120 °C.
3. The enclosure may present a potential electrostatic ignition hazard and must not be rubbed or cleaned with a dry cloth.

## 6.9 International

### 6.9.1 I7 IECEx Intrinsically Safety (IS)

**Certificate:** BAS 15.0098X Issue 5

**Standards:** IEC 60079-0:2017 Edition 7.0, IEC 60079-11: 2011 Edition 6.0

**Markings:** Ex ia IIC T4 Ga, Tamb = -50 °C to +75 °C, IP67

#### Specific Conditions For Safe Use (X):

1. The plastic mounting foot may present a potential electrostatic ignition risk and must not be rubbed or cleaned with a dry cloth.



2. When fitted with the appropriate high-temperature mounting foot, the equipment may be attached to process pipework at a temperature of up to 120 °C.
3. The enclosure may present a potential electrostatic ignition hazard and must not be rubbed or cleaned with a dry cloth.

## 6.10 Brazil

### 6.10.1 I2 INMETRO Intrinsically Safe (IS)

<b>Certificate:</b>	UL-BR 19.1701X
<b>Standards:</b>	ABNT NBR IEC 60079-0:2013 ABNT NBR IEC 60079-11:2013
<b>Markings:</b>	Ex ia IIC T4 Ga (-50 °C ≤ T <sub>amb</sub> ≤ +75 °C)

#### Specific Conditions for Safe Use (X):

1. The plastic mounting foot may present a potential electrostatic ignition risk and must not be rubbed or cleaned with a dry cloth.
2. When fitted with the appropriate high-temperature mounting foot, the equipment may be attached to process pipework at a temperature of up to 120 °C.
3. Enclosures may present a potential electrostatic charging ignition hazard and must not be rubbed or cleaned with a dry cloth.

## 6.11 China

### 6.11.1 I3 China NEPSI Intrinsic Safety

<b>Certificate:</b>	GYJ18.1089X
<b>Standards:</b>	GB3836.1-2010, GB3836.4-2010, GB3836.20-2010
<b>Markings:</b>	Ex ia IIC T4 Ga

#### Specific Condition For Safe Use (X):

See certificate for specific conditions of safe use.

## 6.12 EAC - Kazakhstan and Russia

### 6.12.1 IM (EAC) Intrinsic Safety

<b>Certificate:</b>	C-GB.MIO62.B.05220
<b>Standards:</b>	TP TC 012/2011

**Markings:** 0Ex ia IIC T4 Ga X

**Specific Condition For Safe Use (X)**

See certificate for specific conditions of safe use.

## 6.13 India

### 6.13.1 India (PESO) Intrinsic Safety

**Certificate:** A/P/HQ/MH/104/6455 (P474307)

**Markings:** Ex ia IIC T4 Ga

**Specific Condition For Safe Use (X):**

See certificate for specific conditions of safe use.

## 6.14 Japan

### 6.14.1 I4 CML Intrinsically Safe (IS)

**Certificate:** CML 19JPN2339X

**Standards:** JNIOSH-TR-46-1:2015  
JNIOSH-TR-46-6:2015

**Markings:** Ex ia IIC T4 Ga

**Specific Conditions for Safe Use (X):**

1. The plastic enclosure and mounting foot may present a potential electrostatic ignition risk and must not be rubbed or cleaned with a dry cloth.
2. When fitted with the appropriate high-temperature mounting foot, the equipment may be attached to process pipework at a temperature of up to 120 °C.
3. Enclosures may present a potential electrostatic charging ignition hazard and must not be rubbed or cleaned with a dry cloth.
4. The CC21 Commissioning Cable must only be used in a non-hazardous area – it provides an interface between unspecified non-hazardous area equipment and a Mesh Sensor. It must not be used to provide power whilst located in a hazardous area.

## 6.15 Korea

### 6.15.1 IP Korea (KCS) Intrinsic Safety

**Certificate:** 17-KA4BO-0663X (when supplied from UK)  
20-KA4BO-0505X (when supplied from Singapore)

**Markings:** Ex ia IIC T4

**Specific Condition For Safe Use (X):**

See certificate for specific conditions of safe use

## 6.16 Declaration of Conformity

---

**Figure 6-1: Declaration of Conformity**

### **EU Declaration of Conformity**

We,

Permasense Ltd  
Alexandra House  
Newton Road  
Manor Royal  
Crawley  
RH10 9TT  
UK

declare under our sole responsibility that the product,

ET210 wireless corrosion transmitter

is in conformity with the relevant Union harmonisation legislation:

Electromagnetic compatibility directive (EMC) 2014/30/EU  
Radio equipment directive (RED) 2014/53/EU  
Equipment for explosive atmospheres directive (ATEX) 2014/34/EU

The following harmonised standards and reference standards have been applied:

EMC: EN 61326-1:2013 with radiated emissions to CISPR 11:2009 + A1:2010, Class B

RED: EN 300 328 v2.1.1  
EN 301 489-1 v1.9.2:2011 in accordance with EN 301 489-17 v2.2.1:2012  
with reference to:  
EN 61000-4-2:2009  
EN 61000-4-3:2006 + A1:2008 & 2010  
EN 61010-1:2010

ATEX: EN IEC 60079-0:2018  
EN 60079-11:2012

ATEX notified body:

SGS Fimko Oy (Notified Body number 0598) performed an EU-type examination and issued certificate number Baseefal5ATEX0146X with coding Ⓢ II I G, Ex ia IIC T4 Ga

ATEX notified body for quality assurance:

SGS Fimko Oy (Notified Body number 0598)

Signed for and on behalf of Permasense Ltd.



Dr Jonathan Allin – Chief Technical Officer  
Crawley, UK – 11 November 2020

---

## 6.17 China RoHS

中国 RoHS 2 - 中国《电器电子产品有害物质限制使用管理办法》，2016 年第 32 号令

China RoHS 2 - Chinese order No. 32, 2016; administrative measures for the restriction of hazardous substances in electrical and electronic equipment

作为总部位于美国密苏里州圣路易市艾默生电气公司的一个战略性业务单位及艾默生过程管理的一部分（以下简称“艾默生”），永威™意识到于 2016 年 7 月 1 日生效的中国第 32 号令，即《电器电子产品有害物质限制使用管理办法》（“中国 RoHS 2”），并已设立符合规体系以履行艾默生在第 32 号令项下的相关义务。

Permasense, a strategic business unit of Emerson Electric Co, St. Louis, Missouri and part of Emerson Process Management (“Emerson”), is aware of and has a program to meet its relevant obligations of the Chinese Order No. 32, 2016; Administrative Measures for the Restriction of Hazardous Substances in Electrical and Electronic Equipment (China RoHS 2), which entered into force on 1 July 2016.

艾默生理解中国 RoHS 2 实施的第一阶段须遵守的与产品标识和信息披露等相关的各项要求。作为一个电器电子设备供应商，艾默生确定供应给贵公司的前述型号产品属于中国 RoHS 2 的管理范围。

Emerson understands there are numerous requirements with the regulation regarding, among others, marking of product and communications for purpose of the Phase I implementation of China RoHS 2. As a supplier of electrical and electronic equipment, Emerson has determined that the captioned product supplied to your company is within scope of China RoHS 2.

迄今为止，基于供应商所提供的信息，就艾默生所知，下面表格中列明的部件里存在超过最大浓度限值的中国 RoHS 管控物质，且该产品上已做相应标识。

To date, based on information provided by suppliers and to Emerson's best knowledge, the following China RoHS substances are present at a concentration above the Maximum Concentration Values (“MCVs”), have been identified in the following parts, and the product is marked to reflect this.

含有 China RoHS 管控物质超过最大浓度限值的部件型号列  
List of Model Parts with China RoHS Concentration above MCVs

部件名称 Part Name	有害物质 / Hazardous Substances					
	铅 Lead (Pb)	汞 Mercury (Hg)	镉 Cadmium (Cd)	六价铬 Hexavalent Chromium (Cr +6)	多溴联苯 Polybrominated biphenyls (PBB)	多溴联苯醚 Polybrominated diphenyl ethers (PBDE)
传感器组件 Sensor assembly	X	O	O	O	O	O

本表格系依据 SJ/T11364 的规定而制作。

This table is proposed in accordance with the provision of SJ/T11364

O: 意为该部件的所有均质材料中该有害物质的含量均低于 GB/T 26572 所规定的限量要求。

O: Indicate that said hazardous substance in all of the homogeneous materials for this part is below the limit requirement of GB/T 26572.

X: 意为在该部件所使用的的所有均质材料里，至少有一类均质材料中该有害物质的含量高于 GB/T 26572 所规定的限量要求。

X: Indicate that said hazardous substance contained in at least one of the homogeneous materials used for this part is above the limit requirement of GB/T 26572.







### Emerson Automation Solutions

6021 Innovation Blvd.  
Shakopee, MN 55379, USA

+1 800 999 9307 or +1 952 906 8888

+1 952 949 7001

RFQ.RMD-RCC@Emerson.com

### Latin America Regional Office

Emerson Automation Solutions  
1300 Concord Terrace, Suite 400  
Sunrise, FL 33323, USA

+1 954 846 5030

+1 954 846 5121

RFQ.RMD-RCC@Emerson.com

### Asia Pacific Regional Office

Emerson Automation Solutions  
1 Pandan Crescent  
Singapore 128461

+65 6777 8211

+65 6777 0947

Enquiries@AP.Emerson.com

[Linkedin.com/company/Emerson-Automation-Solutions](https://www.linkedin.com/company/Emerson-Automation-Solutions)

[Twitter.com/Rosemount\\_News](https://twitter.com/Rosemount_News)

[Facebook.com/Rosemount](https://www.facebook.com/Rosemount)

[Youtube.com/user/RosemountMeasurement](https://www.youtube.com/user/RosemountMeasurement)

### North America Regional Office

Emerson Automation Solutions  
8200 Market Blvd.

Chanhassen, MN 55317, USA

+1 800 999 9307 or +1 952 906 8888

+1 952 949 7001

RMT-NA.RCCRFQ@Emerson.com

### Europe Regional Office

Emerson Automation Solutions Europe  
GmbH

Neuhofstrasse 19a P.O. Box 1046

CH 6340 Baar

Switzerland

+41 (0) 41 768 6111

+41 (0) 41 768 6300

RFQ.RMD-RCC@Emerson.com

### Middle East and Africa Regional Office

Emerson Automation Solutions

Emerson FZE P.O. Box 17033

Jebel Ali Free Zone - South 2

Dubai, United Arab Emirates

+971 4 8118100

+971 4 8865465

RFQ.RMTMEA@Emerson.com

©2020 Emerson. All rights reserved.

Emerson Terms and Conditions of Sale are available upon request. The Emerson logo is a trademark and service mark of Emerson Electric Co. Rosemount is a mark of one of the Emerson family of companies. All other marks are the property of their respective owners.