

BOLTON TOOLS

MODEL ZX45 OPERATION MANUAL

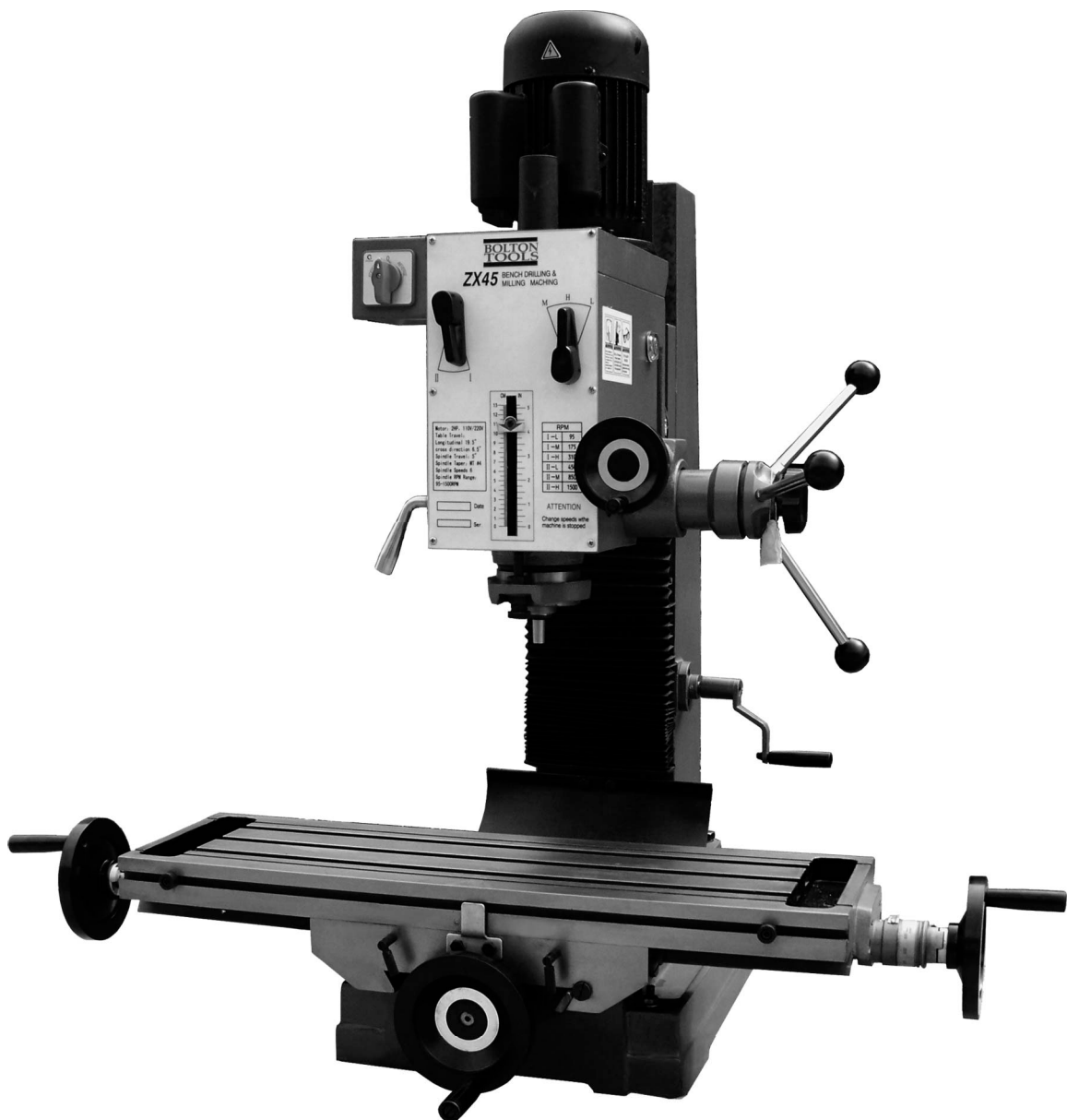

COPYRIGHT © AUGUST, 2008 BY BOLTON HARDWARE
WARNING: NO PORTION OF THIS MANUAL MAY BE REPRODUCED IN ANY SHAPE
OR FORM WITHOUT THE WRITTEN APPROVAL OF BOLTON HARDWARE
PRINTED IN CHINA



WARNING!

This manual provides critical safety instructions on the proper setup, operation, maintenance and service of this machine/equipment. Failure to read, understand and follow the instructions given in this manual may result in serious personal injury, including amputation, electrocution or death.

The owner of this machine/equipment is solely responsible for its safe use. This responsibility includes but is not limited to proper installation in a safe environment, personnel training and usage authorization, proper inspection and maintenance, manual availability and comprehension, application of safety devices, blade/cutter integrity, and the usage of personal protective equipment.

The manufacturer will not be held liable for injury or property damage from negligence, improper training, machine modifications or misuse.

some dust created by power sanding, sawing, grinding, drilling, and other construction activities contains chemicals known to the State of California to cause cancer, birth defects or other reproductive harm. Some examples of these chemicals are:

- **Lead from lead-based paints.**
- **Crystalline silica from bricks, cement and other masonry products.**
- **Arsenic and chromium from chemically-treated lumber.**

Your risk from these exposures varies, depending on how often you Do this type of work. To reduce your exposure to these chemicals: Work in a well ventilated area, and work with approved safety equipment, such as those dust masks that are specially designed to filter out microscopic particles.

Machine Data Sheet

Mill Information	Max.drilling capacity	1-7/9"
	Max.face mill capacity	3-1/7"
	Max.end mill capacity	1-1/9
	Max.tapping capacity	M20/5/8"
	Max.spindle stroke	5-1/9"
	Distance from spindle axis to column	10-2/7"
	Swivel angle of headstock at perpendicular direction	±90°
	Max.distance between spindle nose to table	17-5/7"
	Spindle taper	R8
	Diameter of column	4-1/2"
	Working area of table	31-1/2" x 9-3/7"
	Forward and backward travel of table	6-4/5"
	Left and right travel of table	19-7/10"
	Spindle speeds (4P)	95,175,310,450,850,1500 RPM

Motor	Horsepower	2HP
	Voltage	220V/110V
	Phase	Single
	Amps	8.5A/17A
	Speed	1720
	Bearings	Shielded and Lubricated

Product Dimensions	Approximate Net Weight	706lb
	Overall Dimensions	45-1/3" Wide x 32-2/7" Deep x 41-5/7" Tall
	Approximate Shipping Weight	816lb
	Crate size	46"x33"x42"

IDENTIFICATION

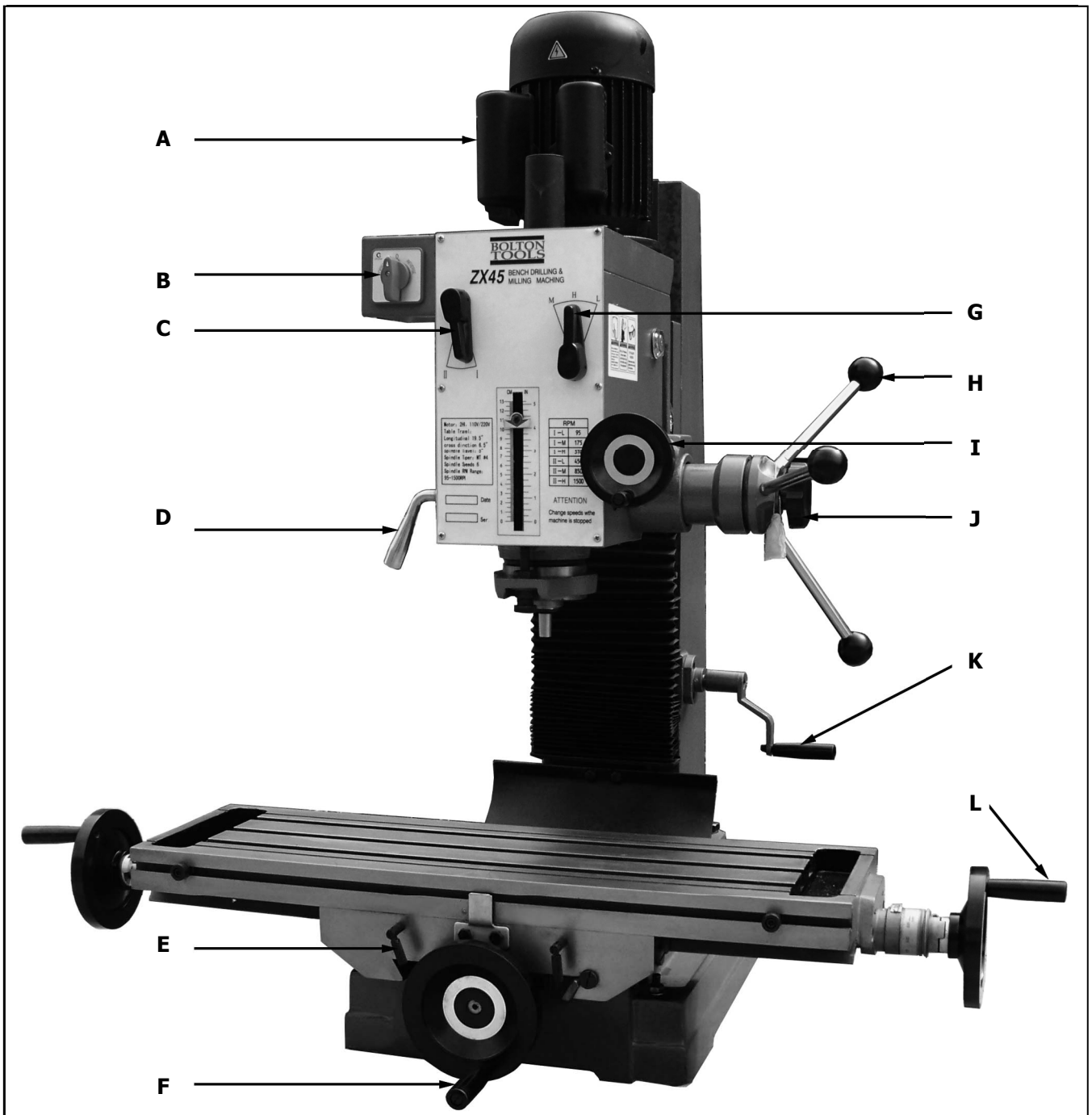

- | | |
|-----------------------------------|-------------------------------------|
| A. Motor | G. Spindle Speed Lever |
| B. Switch | H. Feed Handle |
| C. Spindle Range Lever | I. Micro Feed Handwheel |
| D. Spindle Lock Lever | J. Lock Handle |
| E. Longitudinal Lock screw | K. Rocker |
| F. Cross Slide Handwheel | L. Longitudinal Slide Handle |

 **WARNING!**

For you own safety, read instruction manual be for operating this machine.

As with all machinery, there are certain hazards involved with their operation and use. Exercising respect and caution will considerably lessen the risk of personal injury. However, if normal safety precautions are overlooked or ignored, personal injury to the operator or damage to machinery may result.

Safety Precautions

- 1. Read all instructions before using this machine.**
- 2. Keep guards in place and in working order.**
- 3. Keep work area clean, cluttered area invite injuries.**
- 4. Keep children and visitors away from work area.**
- 5. Dress properly, no loose clothing, gloves neckties, or other jewelry to get caught in moving parts, wear protective hair covering to contain long hair.**
- 6. Always wear eye protection, also use face or dust mask if operation is dusty.**
- 7. Remove adjusting keys and wrenches from tool before starting.**
- 8. Be sure drill bit or cutting tool is securely locked in the chuck.**
- 9. Avoid unintentional starting.**
- 10. Keep proper footing and balance at all times, do not reach over or across running machines.**
- 11. Maintain tools with care, keep tools sharp and clean for better and safer performance.**
- 12. Do not operate this machine while the influence of drug, alcohol or any medication.**
- 13. Use the right tool for the job. do not attempt to force a small tool or attachment to do the work of a larger industrial tool.**
- 14. Ensure this machine is properly grounded.**
- 15. Secure workpiece to keep workpiece from rotating with the drill bit or cutting tool.**



Additional Safety Rules For This Machine

This machine must not be modified for any purpose other than that for which it designed.

- **You should not operate this machine unless you are thoroughly familiar with metal turning lathes and turning techniques. If there is any doubt whatsoever, you should consult a qualified person.**
- **Do not operate the machine until it is completely assembled, and this entire manual, has been read and understood.**
- **Ensure the proper electrical regulations are followed, and that the machine is properly earthed.**
- **Ensure all chuck keys, spanners and removed from the machine.**
- **Examine the setup carefully, ensuring that nothing could possibly interfere with the rotating workpiece.**
- **Ensure the tool post is secure and cutting tool is adjusted to the correct height.**
- **Ensure your clothing is properly adjusted.**
- **Ensure the workpiece is properly secured.**
- **Make all adjustments with the power off**
- **Always cut at speed for the size and type of material being worked.(refer to a suitable turning manual for cutting speeds.)**
- **When you have finished with machine, always remove and store the cutting tools.**
- **When using a coolant, on no account must suds be allowed to enter the electrical system.**

Installation

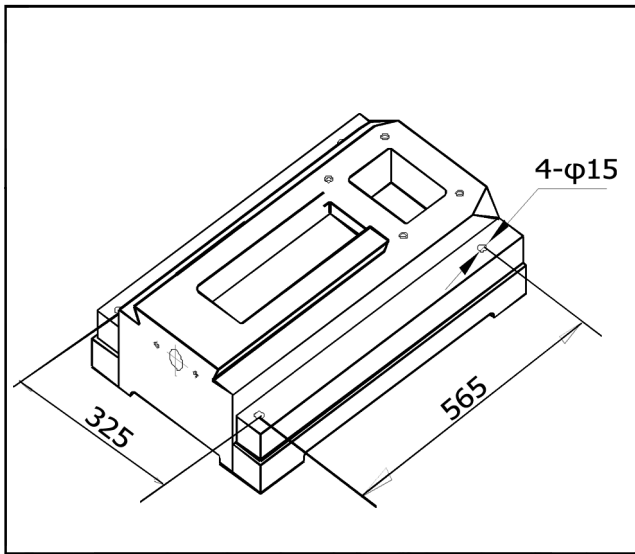

Figure 1. Installation size.

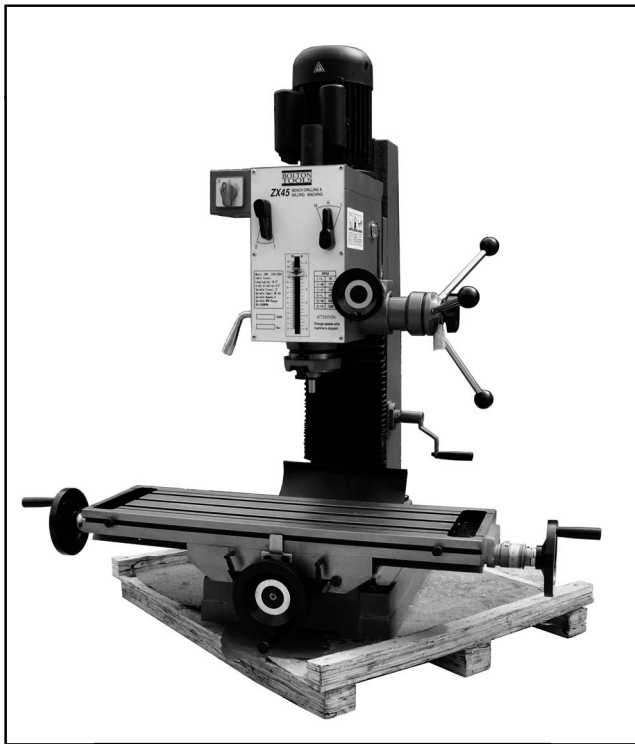

Figure 2. Machine packing.

1. Ensure the headstock is as lower as possible, and be fixed on the column tightly before moving machine. while moving machine, keep its balance and safety.
2. Don't mount the machine at the sunshine place to avoid the deformity of machine and the loss of accuracy.
3. Mount machine to a sturdy table or a solid concrete foundation, it's advisable that the base you choose be well constructed to avoid any vibration during operation.
4. Thoroughly clean the machine with a commercial degreaser, and then coat all bright metal with a light lubricant to prevent corrosion.
5. Level the surface of the worktable on both lengthwise and crosswise by using a precision level.
6. Remove the oil filler plug and fill the oil to the gear box until the oil level reaches the middle of the oil fluid level indicator. Lubricate all points.

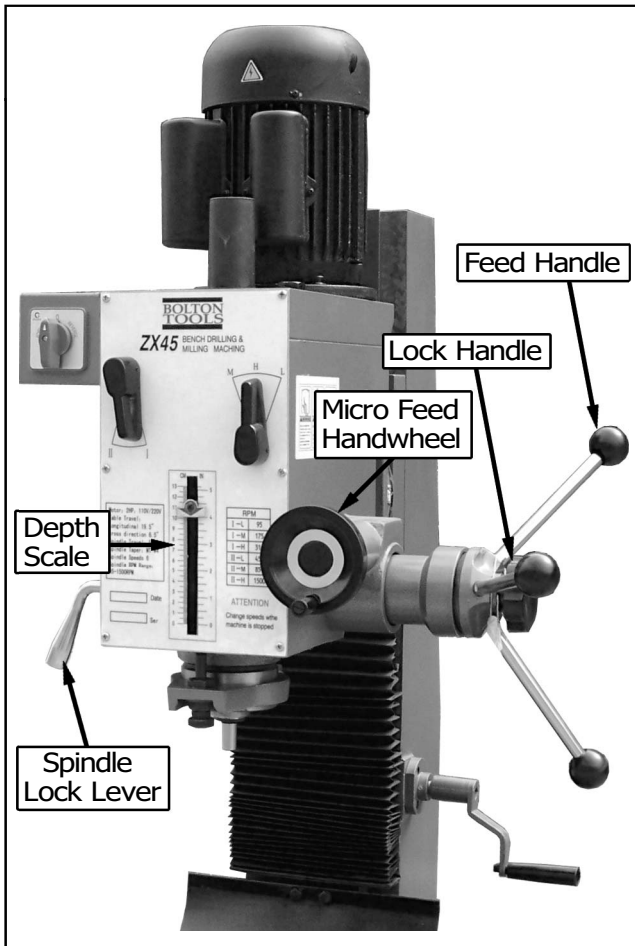

Figure 3. Control handles.

Notice: Check all parts and safety precautions for proper condition before operation.

Use of main machine parts

- (1) Raise and lower the headstock on its rack and pinion mechanism by using the head crank. when the desired height is reached, tighten the bolts to avoid vibration.
- (2) Head may be rotated 360° by loosening the same bolts mentioned above. Adjust the head to the desired angle, then tighten the heavy duty head lock nuts.
- (3) Feed the spindle using spindle feeding handle, micro feed the spindle using the spindle micro feeding handle.
- (4) Move the table from side to side by using the lengthwise table feed wheel, and from front to back by using the cross table feed wheel.
- (5) Adjust the positive depth stop gauge according to working depth.
- (6) Adjust the scale size according to working need.

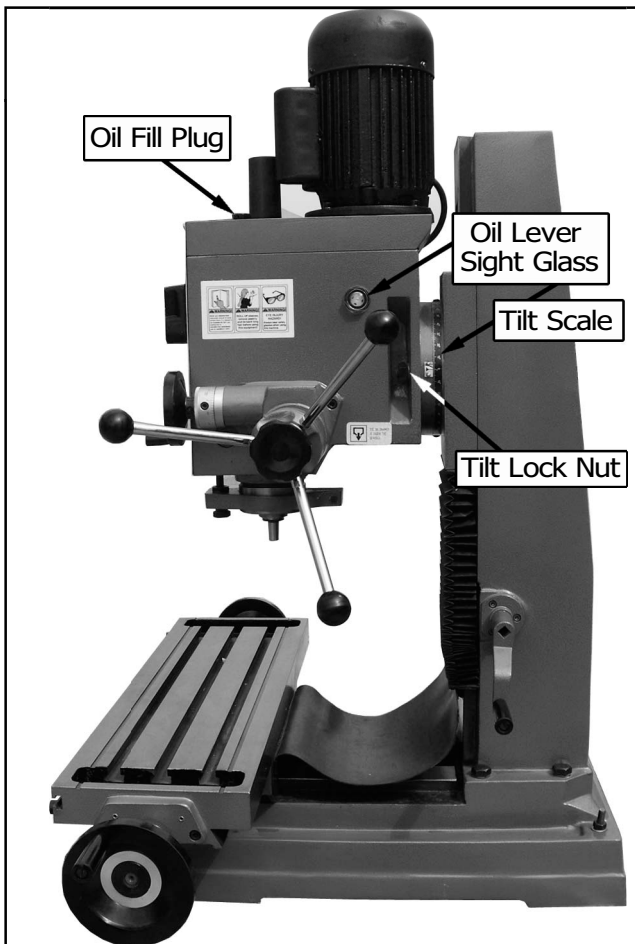

Figure 4. Tilt scale and lock nut.

Drilling operation

- (1) For drilling blind hole (which do not pass through the workpiece), turn off the knob make loose the taper body of worm gear and spring base, then adjust the positive depth stop gauge so that the distance from the tip of the drilling bit to the end of the blind hole is equal to the desired depth.
- (2) For drilling pass hole (which pass through the workpiece), set the positive depth stop gauge in its uppermost position.

Tapping operation

- (1) Loosen the knob in the center of the spindle feeding handle.
- (2) Adjust the positive depth gauge to the required position.
- (3) The switch point to "tapping". When tapping is overload, press down the red emergency switch, and the spindle reverse, the taper turn out.

Milling operation

- (1) Adjust the positive stop depth gauge to its uppermost position.
- (2) Using the spindle feeding handle, adjust the cutter to approximately the correct height, turn off the knob make tighten the taper body of worm and spring base.
- (3) Set the working depth by using the micro feeding handle.
- (4) Lock the rack sleeve at the height with the fixed bolt.
- (5) When longitudinal feeding milling, it is a good idea to lock the across feeding table to ensure the accuracy of your work. To do this, tighten the two screws located on the right side of the table base.
- (6) When cross feeding milling, lock the longitudinal feeding travel, do this by tightening the two screws on the front of the table base.

Adjustment

- (1) Adjustable moveable fixed rings are mounted on the front of the table to limit cross travel.
- (2) Your machine is equipped with gib strip adjustment to compensate for wear and excess slack on cross and longitudinal travel.
- (3) Rotate the gib strip bolt slightly clockwise to tighten the gib trip. rotate it slightly counter-clockwise to loosen the gib trip.
- (4) Adjust the gib trip bolt until very slight drag is felt when moving the table.

Changing machine speed

- (1) **Turn the power off.**
- (2) To select the proper speed, move the speed lever to the desired position .
- (3) If the gear are not engaged, remove the arbor bolt cover. rotate the spindle slightly to engage the gears, then replace the arbor bolt cover.
- (4) Recheck the lever setting, then turn the power on.

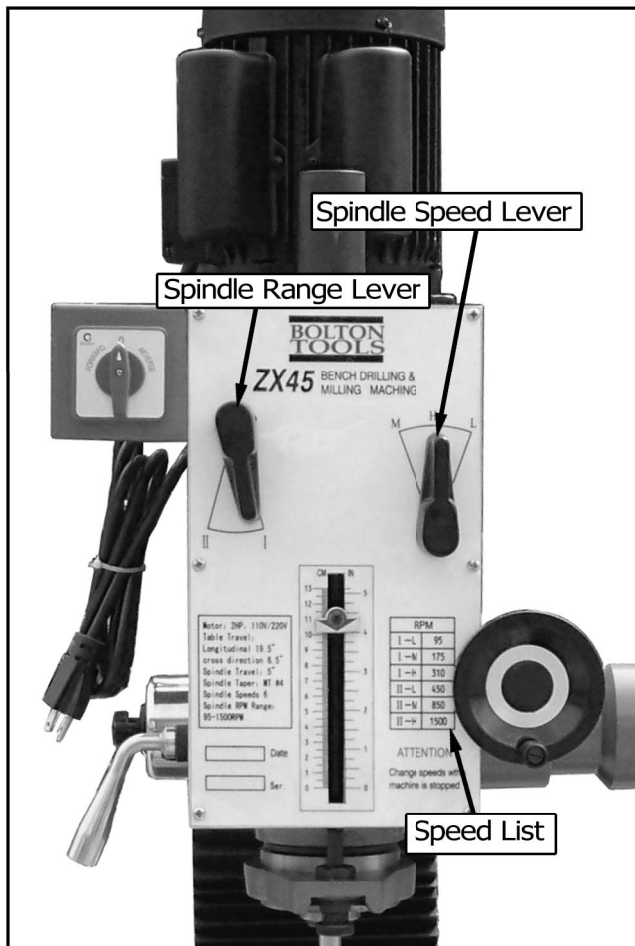

Figure 5. Speed Levers.

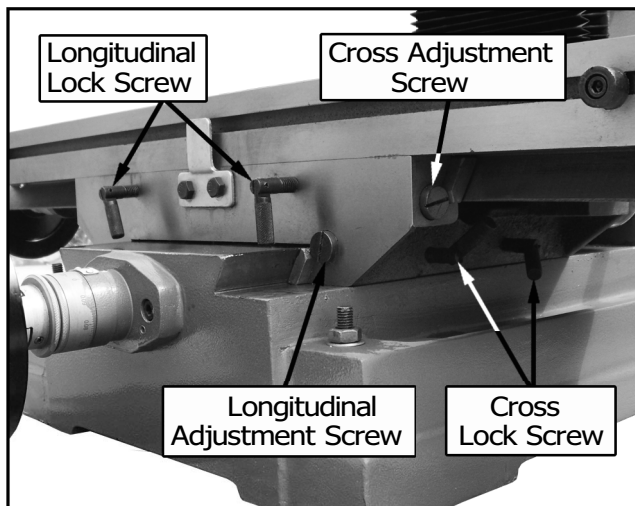

Figure 6. Adjustment screws and Lock screws.

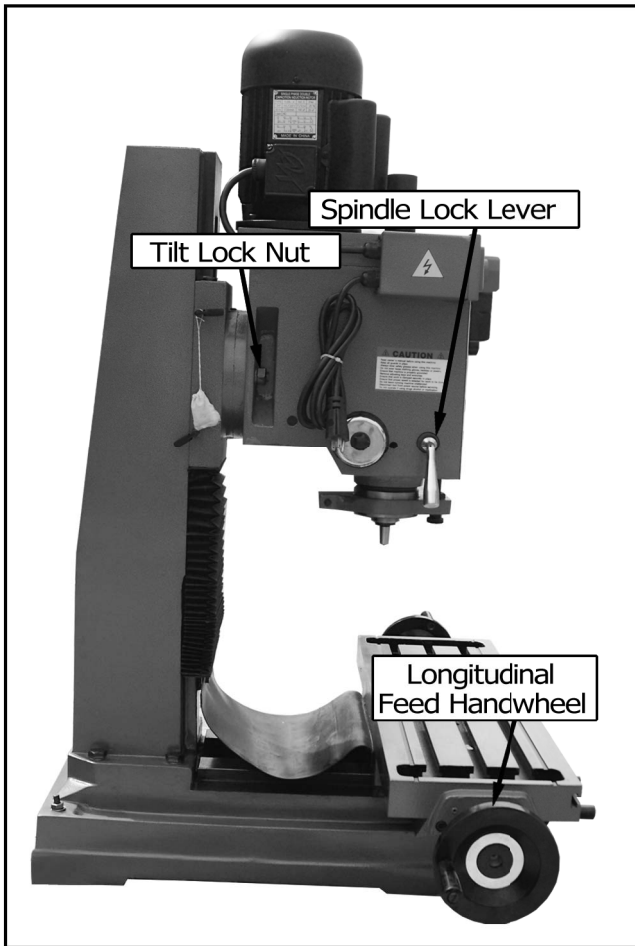

Figure 7. Speed Levers.

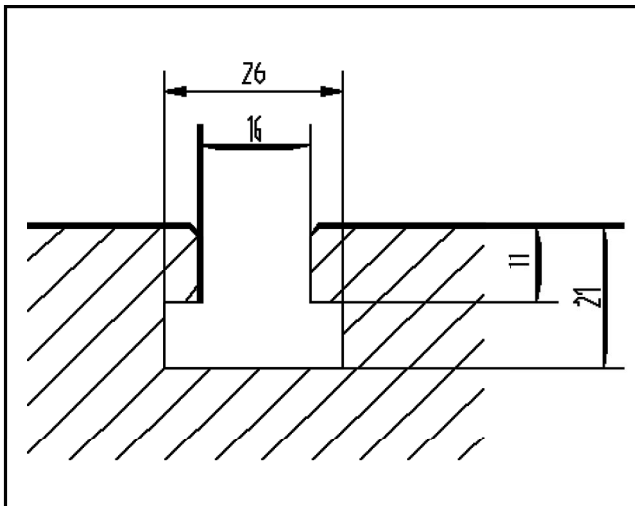

Figure 8. T-slot specification.

Installing and changing tools

Warning: Be sure the power is turned off and the machine unplugged before installing or changing tool bits

- (1) Removing face mill or drill chuck arbor.
Loosen the arbor bolt at the top of the spindle shaft approximately 2 turns with a wrench. Tap the top of the arbor bolt with a mallet. After taper has been broken loose, holding chuck arbor on a hand and turn the arbor bolt with the other hand.
- (2) To install face mill or cutter arbor
Insert cutter and cutter arbor into the taper of spindle. Tighten arbor bolt securely, but do not overtighten.
- (3) Removing taper drills
(a) Turn down the arbor bolt and insert the taper drill into the spindle shaft.
(b) Turn down the rack sleeve until the oblong hole in the rack sleeve appears, lock the rack sleeve, insert wedge through holes and strike lightly with a mallet, this will force the taper drill out.

Ordering replacement parts

Complete parts list is attached , if parts are needed, contact us.

Additional tools and accessories you will find helping

Each of machine is equipped with R8, contact us or a main cutting tool distributor to obtain any of these accessories.

- Taper drill
- Reamers
- End mills
- Cutter arbor
- Taps
- Collets
- Adapters and sleeves

Specification of the T-slot

Please refer to figure, purchase or make T-bolts and other table top fixtures to these dimensions.

Electrical system

⚠ WARNING!

1. A fuse must be connected between machine and power.
2. The ground terminal of machine must be grounded properly.
3. Don't open electrical box during operation, if something is wrong with machine, please ask repairman for help.

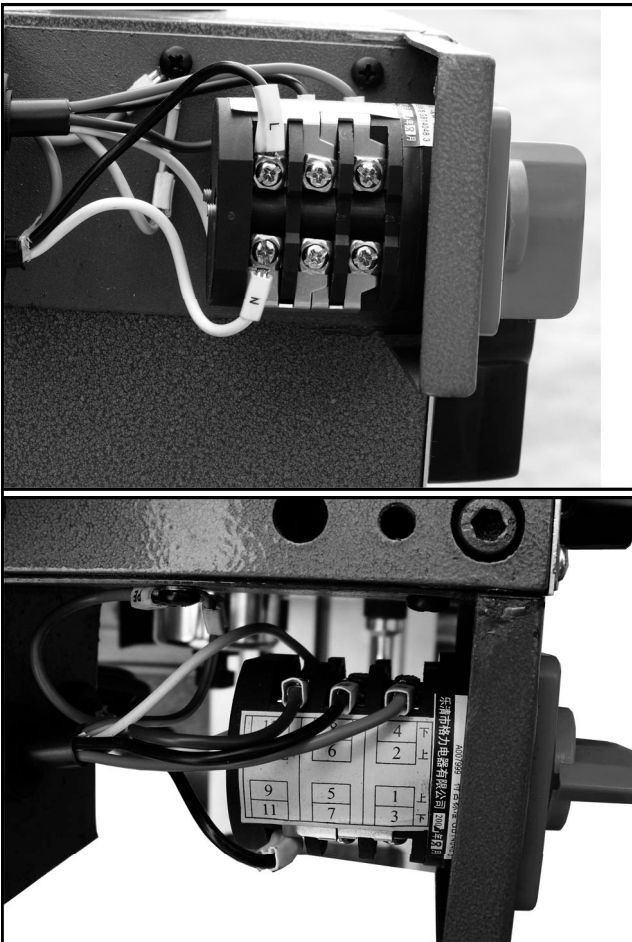

Figure 9. Switch control.

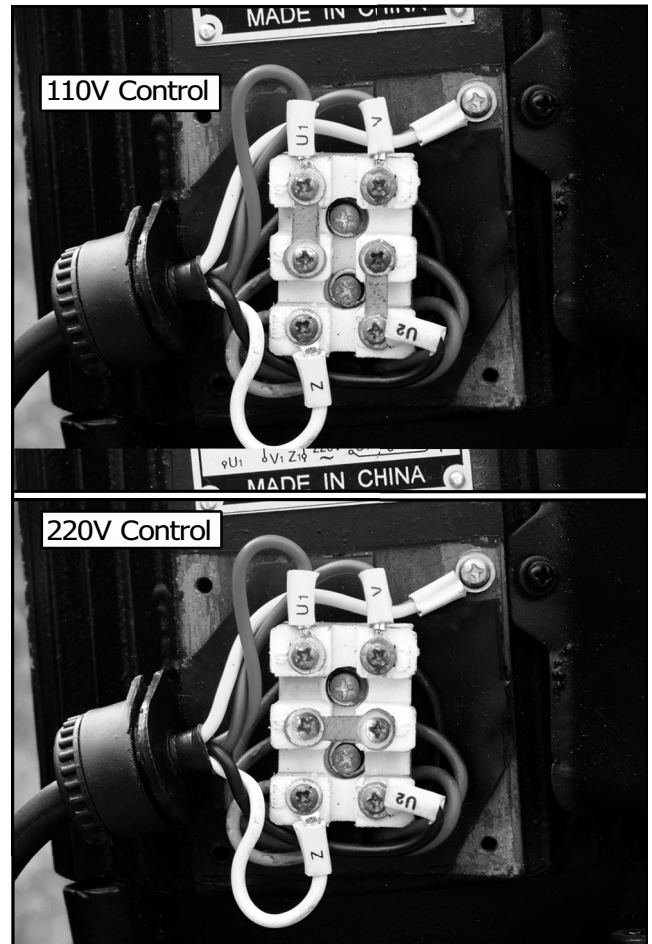

Figure 10. Motor control.

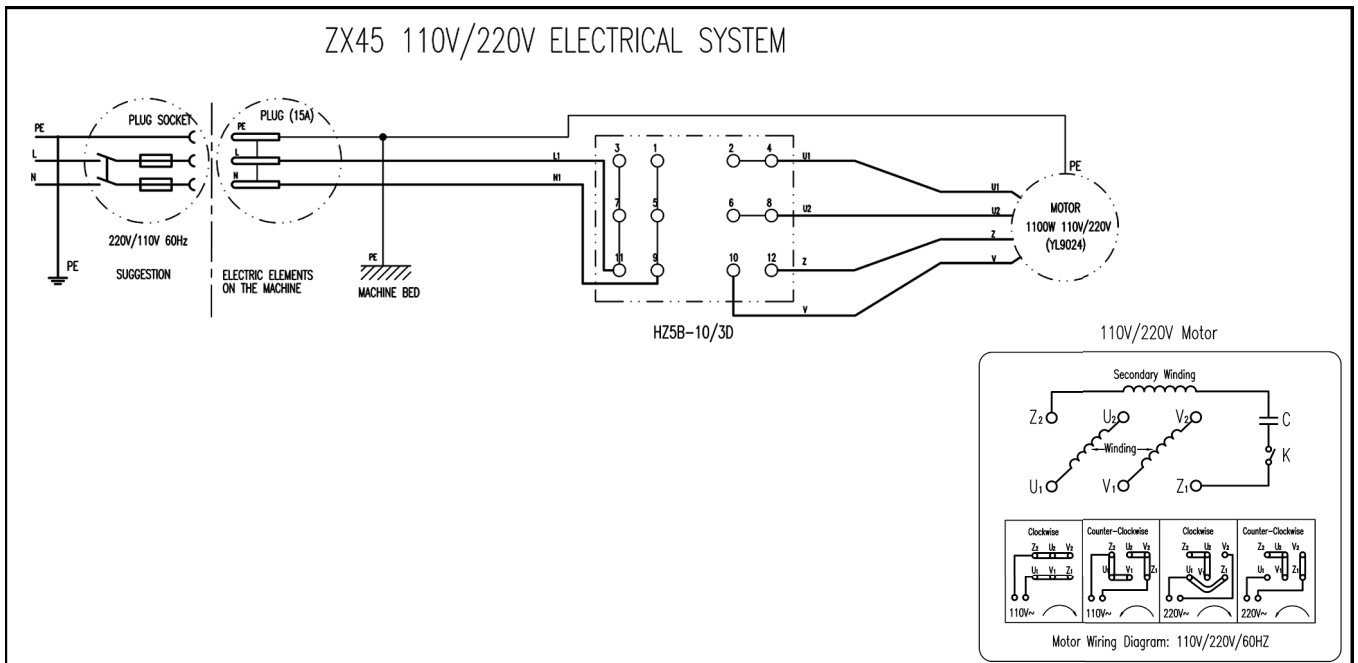

Figure 8. T-slot specification.

Trouble shooting**1. The machine doesn't run when the power switch is turned ON**

- (a) The knob is in the STOP position
- (b) A fuse has burned out---Check in the switch box, and replace it necessary.
- (c) If there is a surge in the current, the circuit breaker may have opened---Press the circuit breaker back, if it is in the open position.
- (d) The gear may not be engaged---Adjust the speed lever to be sure it is engaged.

2. The motor overheats, or there is insufficient power

- (a) The machine is overloaded---Reduce the load of feed.
- (b) The voltage supply is too low---provide with a reliable power supply.
- (c) The switch may have a burned or broken contact point---Replace the switch.
- (d) The contactor relay may be broken---Replace it.
- (e) There may be a poor electrical connection. Have a qualified electrician check the wiring and power supply.
- (f) The motor is poor---replace with new one.
- (g) The drill bit or cutting blade may be worn---Sharpen or replace the bits as needed.

3. The spindle bearing is very hot.

- (a) There is insufficient lubrication---Turn off the power, and check the bearing for lubrication. If necessary, apply bearing grease.
- (b) The spindle bearing is worn, or is fixed too tight---Turn off the power, unplug the electrical connection, and rotate the spindle by hand. Be sure it freely. If not, adjustment the bearing. If you feel no use in the bearing, you will have to replace it.
- (c) The spindle has been turning at high speed for a long time---After Long use, turn the machine off for a while to give it a rest, and allow it to cool off.

4. Table travel is not balanced

- (a) The gap of the table guide is too wide or feel a heavy drag when moving the table---Adjust gib strip in proper
- (b) The locked bolts may be loose---Check and tighten them if necessary.
- (c) The feed is too deep--Reduce the depth of cutting, make several passes to reach the required depth.

5. There is vibration, and roughness of working surface during performance.

- (a) The gap of spindle bearing is too wide---Adjust the gap in proper or replace bearing with new one.
- (b) Spindle loosening up and down---Check the adjustment of the two inner bearing covers. adjust them so there is no free play in the taper bearing, and the bearing turns freely. Tighten them against each other to save this adjustment.
- (c) The gap of the taper sliding plate is too wide---Adjust the bolt tension.
- (d) The chuck is loose--Tighten the chuck.
- (e) The drill bit or cutter is dull--Sharpen or replace it. be sure to use cutting fluid to preserve tool life.
- (f) The workpiece is not held firmly---Check the clamps or vise you are using, and assure to tighten the workpiece.

6. The micro feed does not work smoothly

- (a) The clutch may be loose ---Check this and tighten if necessary.
- (b) The worm or worm shaft may be worn---Check these and replace if necessary.
- (c) The handwheel fixed screw may be loose---Check it and tighten if necessary.

7. The workpiece is not machined accurately

- (a) Imbalance of heavy workpiece---Check to see that heavy workpiece are held in balance. the workpiece Out of balance may shift when being machined
- (b) A hammer has been used on the workpiece---never strike the workpiece with a hammer.
- (c) The table may not be level---check the table with a level to be sure it is level both side to side and front to back.
- (d) The machine may not be stable in the floor--- be sure the machine is firmly mounted to the floor.

Maintenance

1. After each use

- (a) Turn off the power switch.
- (b) Remove any tool bits, clean and lubricate them, and return them to their storage case.
- (c) Using a stiff bristle brush, brush off all chips.
- (d) Using a rag, wipe off any excess or dirty oil or cutting fluid left on the machine.
- (e) Lubricate the points, apply light grease or oil to all unpainted metal to prevent corrosion.
- (f) Cover the machine to prevent dust or dirt contamination when not in use.

2. Daily maintenance

- (a) Fill the oil reservoir to the proper level before each use
- (b) Check the tightness of the bolts holding the head in place.
- (c) If overheating or unusual noises are produced, stop the machine immediately to check for lack of lubrication, faulty adjustments, dull tool bits or other deficiencies, correct any problems before resuming work.
- (d) Keep the work area clean.

3. Weekly maintenance

- (a) Clean and coat the lead screw with oil.
- (b) Check the lubrication of the sliding parts of the table. apply light grease if needed.

4. Monthly maintenance

- (a) Adjust the accuracy of the slides on both the cross and longitudinal feeding.
- (b) Lubricate the bearings, worm gear and worm shaft with light grease.

5. Yearly maintenance

- (a) Adjust the table to assure that it is level in all directions.
- (b) Check the electrical cord, plug, circuit breakers and related connections to assure that they are secure and safe.
- (c) Drain the lubricant from the gear box and replace it.

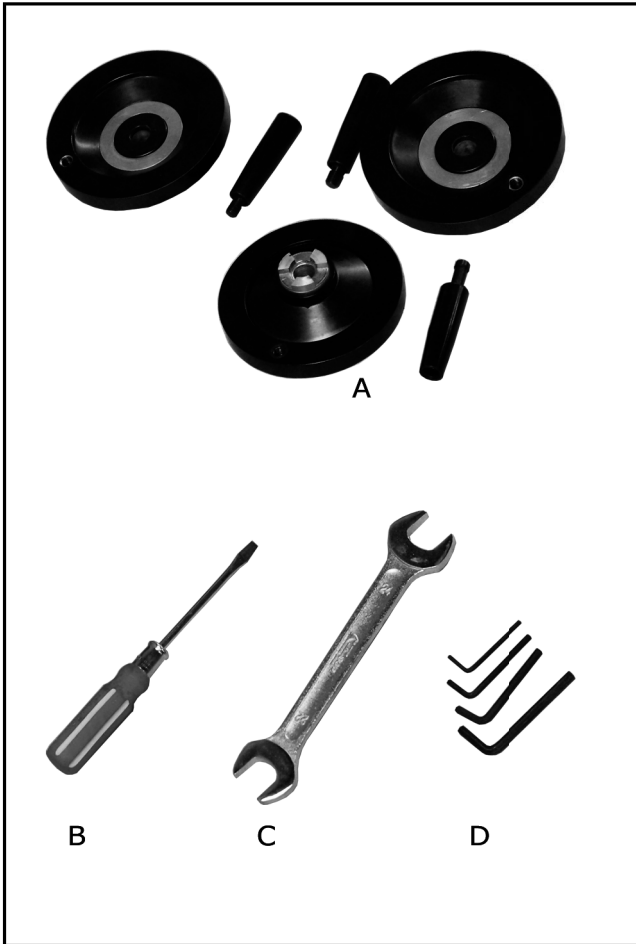

Standard Accessories

The parts have been removed from the box, you should have the following items:

	Qty
A. Handwheel.....	3
B. Driving Screw.....	1
C. Wrench (22-24).....	1
D. Hex Wrench Set(4,5,6,8).....	1 EA

Figure 12. Standard Accessories.

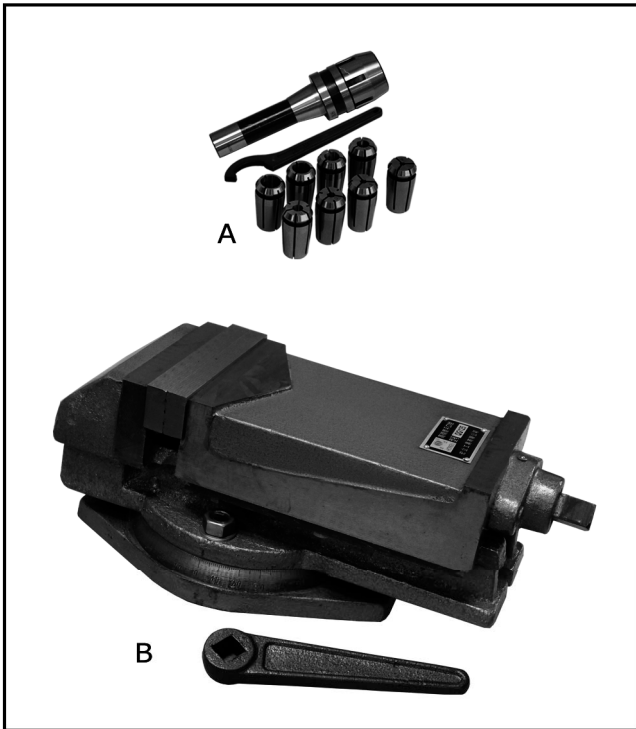

Optional Accessories

- A. End Mill Chuck
- B. Machine Vice

Figure 13. Optional Accessories.

Headstock Diagram

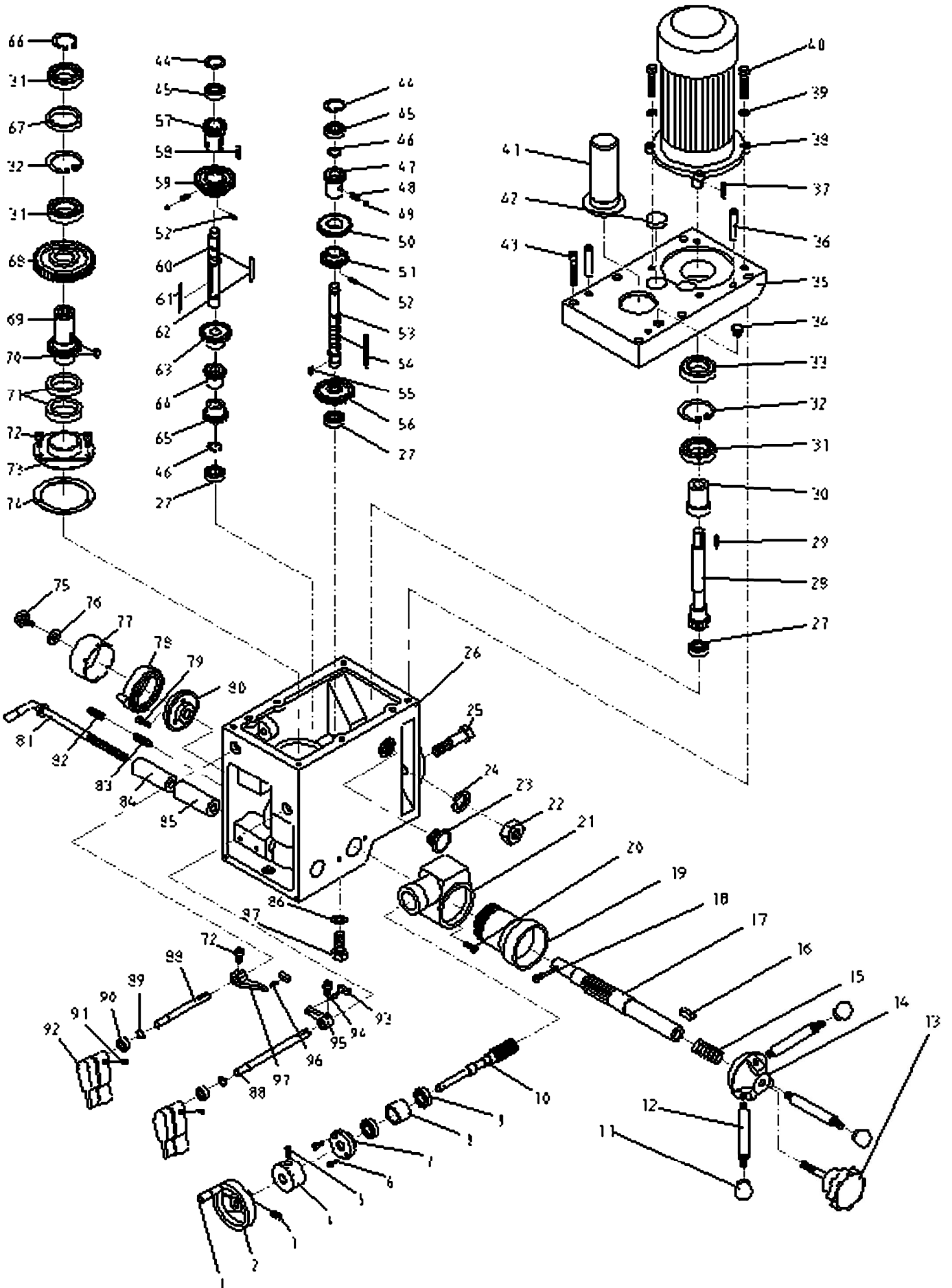

Headstock Parts List

NO.	PARTS	DESCRIPTION	
1	ZX45DP001	Handle	M6*32 JB/T7273.2-94
2	ZX45DP002	Handqheel	12*100 JB/T7270.4-94
3	ZX45DP003	Screw	M5*8GB/T77-85
4	ZX45DP004	Dial seat	XZ32G-30-011
5	ZX45DP005	Screw	M6*14 GB/T70-85
6	ZX45DP006	Screw	M5*14 GB/T70-85
7	ZX45DP007	Cover	XZ32G-30-009
8	ZX45DP008	Bearing spacer	XZ32G-30-008
9	ZX45DP009	Bearing	6202 GB/T276-94
10	ZX45DP0010	worm shaft	XZ32G-30-007
11	ZX45DP0011	Ball knob	M12*40 JB/T7271.1-94
12	ZX45DP0012	Handle lever	BM12*160 JB/T7271.6-94
13	ZX45DP0013	Lock bolt with knob	XZ32G-30-006
14	ZX45DP0014	Spring base	XZ32G-30-004
15	ZX45DP0015	Spring	XZ32G-30-005
16	ZX45DP0016	Key	8*22 GB/T1096-79
17	ZX45DP0017	Gear shaft	XZ32G-30-001
18	ZX45DP0018	Screw	M5*8 GB/T68-85
19	ZX45DP0019	Worm	XZ32G-30-003
20	ZX45DP0020	Screw	M8*20 GB/T70-85
21	ZX45DP0021	Feeding box	XZ32G-30-002
22	ZX45DP0022	Lock nut	M16 GB/T6182-86
23	ZX45DP0023	Fluid lever indicator	M27*1.5 GB/T1162.2-89
24	ZX45DP0024	Spring washer	16 GB/T93-87
25	ZX45DP0025	Bolt	M16*65 GB/T5782-86
26	ZX45DP0026	Head body	XZ32G-20-001
27	ZX45DP0027	Bearing	6003 GB/T276-94
28	ZX45DP0028	Gear	XZ32G-20-024
29	ZX45DP0029	Key	5*25 GB/T1096-79
30	ZX45DP0030	Shaft cover	XZ32G-20-019
31	ZX45DP0031	Bearing	6007 GB/T276-94
32	ZX45DP0032	Retain ring (external)	62 GB/T893.1-86
33	ZX45DP0033	Oil seal	B35*62*12 GB/T9877.1
34	ZX45DP0034	Oil filler plug	XZ32G-20-032
35	ZX45DP0035	Head body cover	XZ32G-20-012
36	ZX45DP0036	Taper pin	10*50 GB/T118-86
37	ZX45DP0037	Key	6*35 GB/T1096-79
38	ZX45DP0038	Motor	
39	ZX45DP0039	Washer	8 GB/T96-87
40	ZX45DP0040	Screw	M8*25 GB/T5781-86
41	ZX45DP0041	Arbor bolt cover	XZ32G-20-014
42	ZX45DP0042	Cap	XZ32G-20-016
43	ZX45DP0043	Screw	M8*55 GB/T70-85
44	ZX45DP0044	Reainer	35 GB/T893.1-86
45	ZX45DP0045	Bearing	6202 GB/T276-94
46	ZX45DP0046	Inner ring	18 GB/T894.1-86
47	ZX45DP0047	Gear	XZ32G-20-020
48	ZX45DP0048	Spring	GB/T2089-84
49	ZX45DP0049	Steel ball	8 GB/T308-84
50	ZX45DP0050	Gear	XZ32G-20-021

Headstock Parts List

NO.	PARTS	DESCRIPTION	
51	ZX45DP0051	Gear	XZ32G-20-022
52	ZX45DP0052	Screw	M5*8 GB/T73-85
53	ZX45DP0053	Shaft	XZ32G-20-018
54	ZX45DP0054	Key	5*60 GB/T1096-79
55	ZX45DP0055	Key	6*12 GB/T1096-79
56	ZX45DP0056	Gear	XZ32G-20-025
57	ZX45DP0057	Gear	XZ32G-20-017
58	ZX45DP0058	Key	6*28 GB/T1096-79
59	ZX45DP0059	Gear	XZ32 G-20-007
60	ZX45DP0060	Shaft	XZ32G-20-003
61	ZX45DP0061	Key	6*75 GB/T1096-79
62	ZX45DP0062	Key	5*50 GB/T1096-79
63	ZX45DP0063	Gear	XZ32G-20-006
64	ZX45DP0064	Gear	XZ32G-20-005
65	ZX45DP0065	Gear	XZ32G-20-004
66	ZX45DP0066	Retain ring(external)	35 GB/T893.1-86
67	ZX45DP0067	Spacer	XZ32G-20-013
68	ZX45DP0068	Gear	XZ32G-20-011
69	ZX45DP0069	Spindle sleeve gear	XZ32G-20-010
70	ZX45DP0070	Key	6*18 GB/T1096-79
71	ZX45DP0071	Oil seal	B35*45*10 GB/T9877.1-88
72	ZX45DP0072	Screw	M5*14 GB/T70-85
73	ZX45DP0073	Lever	XZ32G-20-008
74	ZX45DP0074	Gasket ring	XZ32G-20-009
75	ZX45DP0075	Screw knob	XZ32G-20-038
76	ZX45DP0076	Washer	XZ32G-20-039
77	ZX45DP0077	Spring cover	XZ32G-20-036
78	ZX45DP0078	Spring	XZ32G-20-037
79	ZX45DP0079	Screw	M5*10 GB/T70-85
80	ZX45DP0080	Spring base	XZ32G-20-040
81	ZX45DP0081	Lock handle	XZ32G-20-042
82	ZX45DP0082	Screw	M10*10 GB/T77-85
83	ZX45DP0083	Screw	M10*25 GB/T79-85
84	ZX45DP0084	Fixed tight collar A	XZ32G-20-041A
85	ZX45DP0085	Fixed tight collar B	XZ32G-20-041B
86	ZX45DP0086	Gasket ring	9.8*2.65 GB/T3452.1-92
87	ZX45DP0087	Screw	M12*1.5 GB/T70-85
88	ZX45DP0088	Lever shaft(short)	XZ32G-20-029
89	ZX45DP0089	Retain ring (external)	12 GB/T894.1-86
90	ZX45DP0090	Oil seal	B12*22*7 GB/T9877.1-88
91	ZX45DP0091	Spring pin	3*22 GB/T879-86
92	ZX45DP0092	handle	XZ32G-20-031
93	ZX45DP0093	Fork	XZ32G-20-026
94	ZX45DP0094	Pin shaft	XZ32G-20-027
95	ZX45DP0095	Lever	XZ32G-20-028
96	ZX45DP0096	Spring pin	4*12 GB/T879-86
97	ZX45DP0097	Lever	XZ32G-20-030

Table Diagram

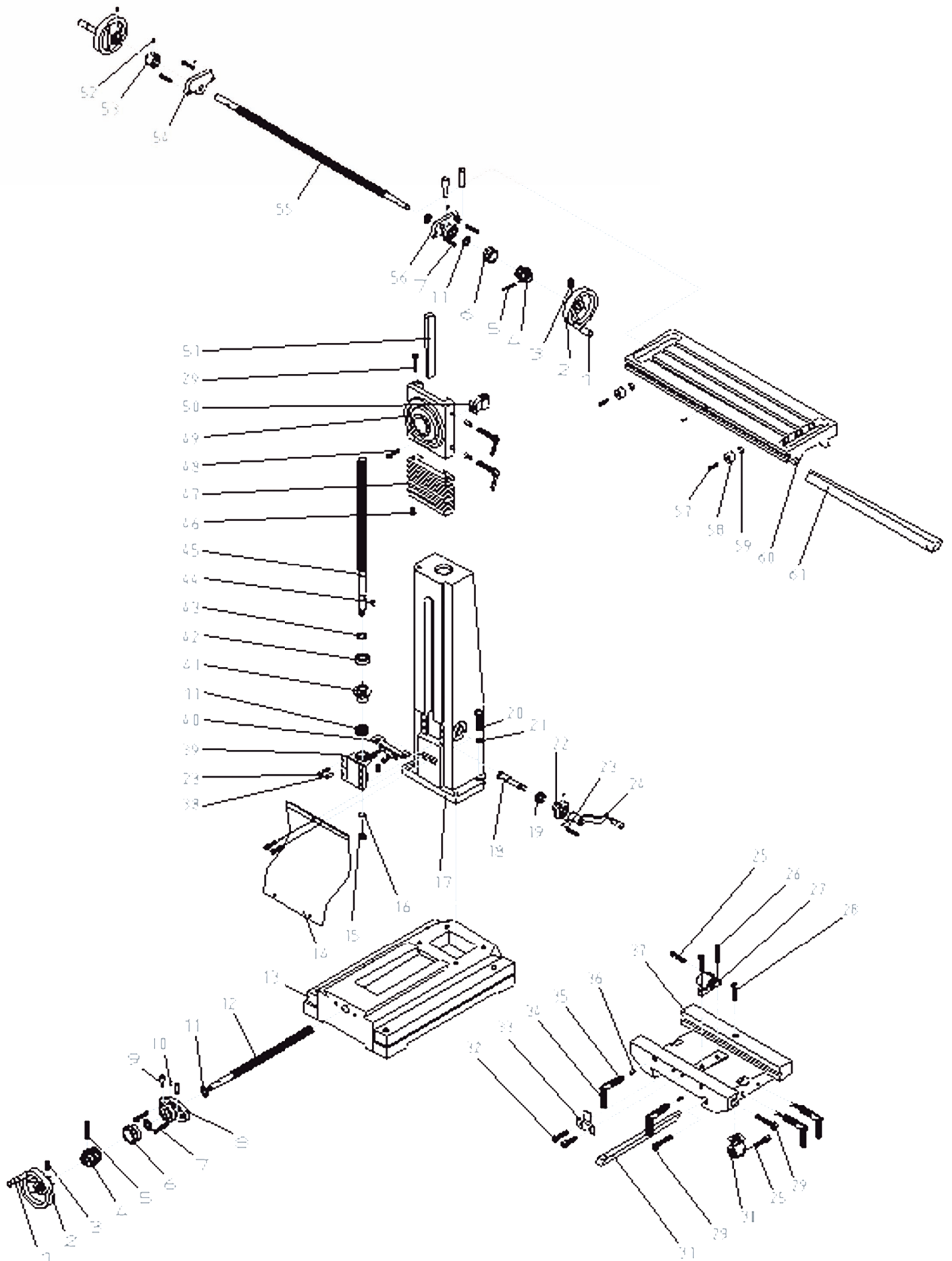

Table Parts List

NO.	PARTS	DESCRIPTION	
1	ZX45TB001	Handle	BM10×80 GB/T7270.4
2	ZX45TB002	Hand wheel	XZ32 G-10-001
3	ZX45TB003	Screw	M6×10 GB/T73-85
4	ZX45TB004	Dial clutch	XZ32G-10-002
5	ZX45TB005	Spring pin	5×40 GB/T879-86
6	ZX45TB006	Dial ring	XZ32G-10-044
7	ZX45TB007	Screw	M8×16 GB/T70-85
8	ZX45TB008	Square flange	XZ32G-10-003
9	ZX45TB009	Taper pin	8×30 GB/T118-86
10	ZX45TB0010	Oil cup	JB/T7940.4-95
11	ZX45TB0011	Thrust bearing	51103 GB/T301-94
12	ZX45TB0012	Cross Lead Screw	XZ32G-10-004
13	ZX45TB0013	Base	XZ32G-10-005
14	ZX45TB0014	Anti-dust plate	XZ32G-10-008
15	ZX45TB0015	Nut	M16×1.5 GB/T810-88
16	ZX45TB0016	Stop washer	16 GB/T858-76
17	ZX45TB0017	Square column	XZ32G-10-037
18	ZX45TB0018	Tap gear shaft	XZ32G-10-028
19	ZX45TB0019	Thrust bearing	51102 GB/T301-94
20	ZX45TB0020	Screw	M16×60 GB/T5782-86
21	ZX45TB0021	Spring washer	GB/T93-87
22	ZX45TB0022	Bracket	XZ32G-10-031
23	ZX45TB0023	Screw	M6×20 GB/T70-85
24	ZX45TB0024	Head handle	XZ32G-10-030
25	ZX45TB0025	Screw	M5×14 GB/T70-85
26	ZX45TB0026	Screw	M8×25 GB/T70-85
27	ZX45TB0027	Longitudinal Nut	XZ32G-10-006
28	ZX45TB0028	Screw	M8×45 GB/T70-85
29	ZX45TB0029	Adjustable Screw	XZ32G-10-011
30	ZX45TB0030	Cross lead Nut	XZ32G-10-007
31	ZX45TB0031	Gib strip(short)	XZ32G-10-013
32	ZX45TB0032	Screw	M8×12 GB/T5781-85
33	ZX45TB0033	Moveable fixed block	XZ32G-10-043
34	ZX45TB0034	Handle	XZ32G-10-012(2)
35	ZX45TB0035	Lock screw	XZ32G-10-012(1)
36	ZX45TB0036	Pin	XZ32G-10-020
37	ZX45TB0037	Center base	XZ32G-10-014
38	ZX45TB0038	Pin	8×20 GB/T119-86
39	ZX45TB0039	Support	XZ32G-10-021
40	ZX45TB0040	Connective plate	XZ32G-10-041

Table Parts List

NO.	PARTS	DESCRIPTION	
41	ZX45TB0041	Taper gear	XZ32G-10-032
42	ZX45TB0042	Bearing	6204-2RS GB/T276-94
43	ZX45TB0043	Retain ring	20 GB/T894.1-86
44	ZX45TB0044	Key	5×12 GB/T1096-79
45	ZX45TB0045	Screw	XZ32G-10-022
46	ZX45TB0046	Screw	M5×10 GB/T67-85
47	ZX45TB0047	Cover	XZ32G-10-039
48	ZX45TB0048	Screw	M8×40 GB/T70-85
49	ZX45TB0049	Connective base	XZ32G-10-023
50	ZX45TB0050	Nut	XZ32G-10-038
51	ZX45TB0051	Gip strip	XZ32G-10-026
52	ZX45TB0052	Screw	M10×8 GB/T77-85
53	ZX45TB0053	Dial clutch	XZ32G-10-016
54	ZX45TB0054	Square flange	XZ32G-10-015
55	ZX45TB0055	Longitudinal lead screw	XZ32G-10-017
56	ZX45TB0056	Square flange	XZ32G-10-009
57	ZX45TB0057	Screw	M6×15 GB/T70-85
58	ZX45TB0058	Moveable fixed ring	XZ32G-10-018
59	ZX45TB0059	Fixed block	XZ32G-10-019
60	ZX45TB0060	Table	XZ32G-10-042
61	ZX45TB0061	Gip strip(long)	XZ32G-10-010

Spindle Diagram

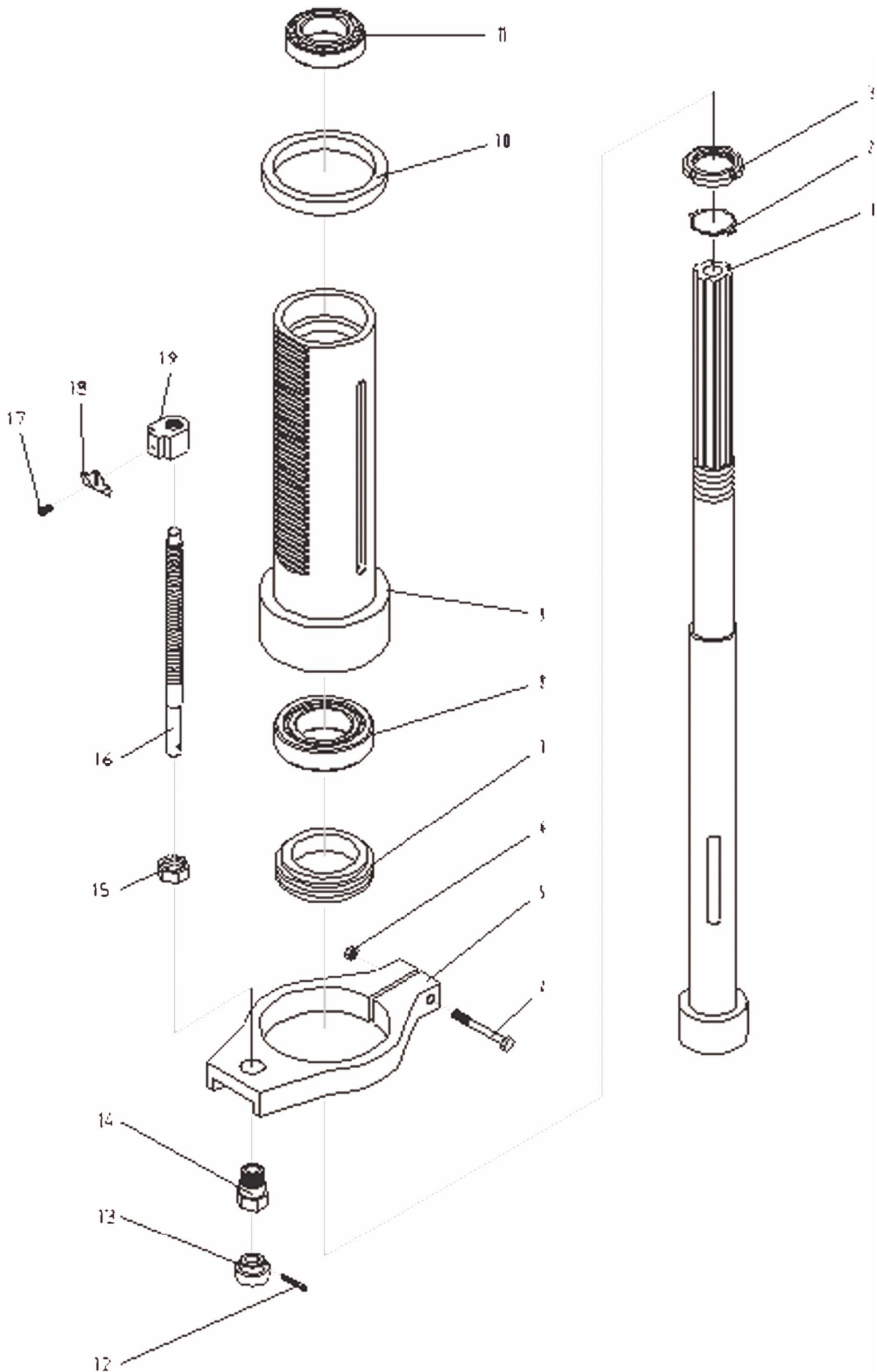

Spindle List

NO.	PARTS	DESCRIPTION	
1	ZX45SP001	Spindle	XZ32G-21-001
2	ZX45SP002	Stop washer	30 GB/T858-88
3	ZX45SP003	Nut	M30×1.5 GB/T810-86
4	ZX45SP004	Bolt	M6×50 GB/T5780-86
5	ZX45SP005	Graduate rod base	XZ32G-21-003
6	ZX45SP006	Nut	M6 GB/T41-86
7	ZX45SP007	Anti-dust cover	XZ32G-21-002
8	ZX45SP008	Bearing	30207/P6 GB/T297-94
9	ZX45SP009	Rack sleeve	XZ32G-21-005
10	ZX45SP0010	Rubber flange	XZ32G-21-004
11	ZX45SP0011	Bearing	30206/P6 GB/T297-94
12	ZX45SP0012	Spring pin	φ3×18 GB/T879-86
13	ZX45SP0013	Handle	XZ32G-21-010
14	ZX45SP0014	Support	XZ32G-21-009
15	ZX45SP0015	Thin nut	M16 GB/T6172-86
16	ZX45SP0016	Graduate rod	XZ32G-21-006
17	ZX45SP0017	Screw	M4×6 GB/T818-85
18	ZX45SP0018	Indicating plate	XZ32G-21-008
19	ZX45SP0019	Set position	XZ32G-21-007

Warranty

Bolton Tools Inc. warrants all Bolton Tools machinery to be free of defect from workmanship and materials for a period of one year from the date of original purchase by the original purchaser. This warranty does not apply to damage due directly or indirectly to misuse, lack of maintenance, abuse, negligence, accidents, repairs or alterations outside of our facilities.

To take advantage of this warranty, items that fail under guarantee can be returned to us. Responsibility for safe return of freight is with the customer. Please ensure a clear explanation of the fault is included with any return. If our inspection verifies the defect, we will either repair or replace the product at our discretion or we may elect to refund the purchase price if we cannot readily and quickly provide you with a replacement. We will return repaired products at our expense, but if it is determined there is no defect, or that the defect resulted from cause not within the scope of our warranty, then the original owner must bear the cost of storing and returning the product. In order to place a warranty claim you must contact our Customer Service Department at (877)888-5913. Proof of purchase must accompany the merchandise.

The sole written warranty and all warranties that may be implied by law include any merchantability or fitness, for any particular purpose, are hereby limited to the duration of this written warranty.

We shall in no event be liable for death, injuries to persons or property for incidental, contingent, special or consequential damages arising from the use of our products. Some states do not allow the exclusion or limitation of incidental or consequential damages, so the above limitation of exclusion may not apply to you.

Title: Mr/Mrs/Miss/Ms Surname

Forename:

Address:

Postal Town:

County:

Post Code:

E-mail address:

Product Purchased Date of Purchase i. e. 01/01/2000

Model No:

Description:

Serial No (IF ANY):

The following information is given on a voluntary.
 It will be used for marketing purposes to help us develop better products and services
 Of course ,all information is strictly confidential.

Application Type (tick one or more)

<input type="checkbox"/> Bodyshop	<input type="checkbox"/> Garage
<input type="checkbox"/> Fleet Maintenance Dept	<input type="checkbox"/> Agricultural Engineer
<input type="checkbox"/> Industrial Maintenance	<input type="checkbox"/> Local Utility
<input type="checkbox"/> Other (Specify) <input type="text"/>	

Which Publications do you regularly read (tick one or more)

<input type="checkbox"/> Popular Mechanics	<input type="checkbox"/> Home Shop Machinist
<input type="checkbox"/> Hand Loader	<input type="checkbox"/> Modeltec
<input type="checkbox"/> Family Handyman	<input type="checkbox"/> Popular Science
<input type="checkbox"/> RC Modler	<input type="checkbox"/> Wood
<input type="checkbox"/> Today's Homeowner	<input type="checkbox"/> Cabinet Maker
<input type="checkbox"/> Rifle	<input type="checkbox"/> Shop notes
<input type="checkbox"/> Live Steam	<input type="checkbox"/> Shotgun News
<input type="checkbox"/> Woodshop news	<input type="checkbox"/> Journal of light Cont.
<input type="checkbox"/> Other (Specify) <input type="text"/>	

WHERE DO YOU NORMALLY BUY YOUR MACHINE?
 COMPANY:

TOWN:

HOW MUCH DO YOU SPEND ON TOOLS AND EQUIPMENT PER YEAR?

<input type="text"/>	<input type="text"/>	<input type="text"/>	<input type="text"/>
UNDER \$200	\$200-500	\$500-800	
\$800-1000	\$1000-2000	\$2000+	

WHAT IS YOUR PERCEPTION/EXPERIENCE OF BOLTON TOOLS?
 PUT A CROSS ON YOU CHOICE

(ONE ONLY PER LINE)	EXCELLENT	GOOD	AVERAGE	BELOW	POOR
PRODUCT QUALITY	1	2	3	4	5
PRODUCT RANGE	1	2	3	4	5
SPARE PART SERVICE	1	2	3	4	5
TELESALES SERVICE	1	2	3	4	5
INTERNET SITE	1	2	3	4	5
PROMOTIONS	1	2	3	4	5
WARRANTIES	1	2	3	4	5
PRODUCT VALUE	1	2	3	4	5
DELIVERY	1	2	3	4	5

WHAT ITEMS NOT CURRENTLY INCLUDED WOULD YOU LIKE TO SEE IN OUR CATALOGUE?

ANY OTHER COMMENTS?

THANK YOU FOR COMPLETING THIS QUESTIONNAIRE.

This information is primarily held for warranty and marketing analysis. From time to time we may update you with information of our newest products. We may also provide your details to other parties where we feel their services or products may be of interest to you. If you do not wish us to mail or forward information using you details please tick here: