

August 9, 2019

Version 1

Warranty Extension: A/C Condenser Leaking

AFFECTED VEHICLES

Year	Model	Trim	VIN Range
2016	Civic	ALL	Check the iN VIN status for eligibility.
2017	Civic	ALL	Check the iN VIN status for eligibility.
2018	Civic	ALL	Check the iN VIN status for eligibility.

BACKGROUND

American Honda is extending the warranty on the A/C condenser to 10 years from the original date of purchase with unlimited miles.

This warranty only covers vehicles that have a defective A/C condenser from the factory. The A/C condenser was not manufactured to specification. As a result, tiny holes may develop in the condenser tube walls that allows the refrigerant to leak out.

The warranty extension does not apply to any vehicle that has a leaking condenser due to foreign object damage.

The warranty extension does not apply to any vehicle that has ever been declared a total loss or sold for salvage by a financial institution or insurer, or has a branded or similar title under any state's law.

CUSTOMER NOTIFICATION

Owners of affected vehicles will be sent a notification of this campaign.

Do an iN VIN status inquiry to make sure the vehicle is shown as eligible.

CORRECTIVE ACTION

Do the inspection procedure and, if there is a leak in the A/C condenser that is caused by corrosion, replace it.

CUSTOMER INFORMATION:The information in this bulletin is intended for use only by skilled technicians who have the proper tools, equipment, and training to correctly and safely maintain your vehicle. These procedures should not be attempted by "do-it-yourselfers," and you should not assume this bulletin applies to your vehicle, or that your vehicle has the condition described. To determine whether this information applies, contact an authorized Honda automobile dealer.

PARTS INFORMATION

Part Name	Part Number	Quantity
Condenser Assembly (2.0 L)	80100-TBA-A01	1
Condenser Assembly (1.5 L)	80100-TBC-A01	1
O-Ring (1/2 in)	80872-SN7-003	1
O-Ring (8 mm)	80873-ST7-000	1

REQUIRED MATERIAL

NOTE

Once the POE Compressor Oil container is opened, throw it away; do not store it or reuse it.

Part Name	Part Number	Quantity
POE Compressor Oil	38899-RLV-A01	1
1234yf Refrigerant	08799-0003	Refer to service bulletin 16-064 for calculation instructions.

TOOL INFORMATION

Tool Name	Tool Number	Quantity
R-1234yf A/C Recover, Recycle, Recharge Machine	ROB421234	1
R-1234yf Leak Detection Kit	TRP1234yf	1
Dual Mode Refrigerant Gas Leak Detector or Infrared Refrigerant Leak Detector	ROBLD020 or ROB22791	1

WARRANTY CLAIM INFORMATION

Civic 1.5 L & 2.0 L

Operation Number	Description	Flat Rate Time	Defect Code	Symptom Code	Template ID	Failed Part Number
6165A0	Inspect the A/C system for leaks.	0.5 hr	6C300	G5000	A19091A	80100-TBA-A01

Civic 1.5 L Only

Operation Number	Description	Flat Rate Time	Defect Code	Symptom Code	Template ID	Failed Part Number
6165A0	Inspect the A/C system for leaks.	0.5 hr	6C300	G5000	A19091B	80100-TBA-A01
A	Replace the condenser (1.5 L).	1.5 hr				

Civic 2.0 L Only

Operation Number	Description	Flat Rate Time	Defect Code	Symptom Code	Template ID	Failed Part Number
6165A0	Inspect the A/C system for leaks.	0.5 hr	6C300	G5000	A19091C	80100-TBA-A01
B	Replace the condenser (2.0 L).	1.6 hr				

Skill Level: Repair Technician

INSPECTION PROCEDURE

1. Check if the condenser is leaking.

NOTE

For additional information on how to check if the condenser is leaking, go to service bulletin 07-030 *A/C Leak Detection* and 18-073 *Bosch ROBLD020 Dual Mode Refrigerant Gas Leak Detector*.

- 1.1. Start the engine.
- 1.2. Turn on the A/C, and set the climate control to MAX COOL.

NOTE

If the refrigerant level is low, the compressor may not activate. Fill the system with enough refrigerant to engage the compressor. However, if there is a leak in the system, the vacuum leak test may fail and you will be unable to add refrigerant to the system. In that case, use the ultrasonic leak detector with the system in a vacuum to identify where the leak is. Watch the *Tech2Tech* video, "Check for A/C Leaks with the Ultra Sonic Leak Detector" on how to use the ultra sonic leak detector.

- 1.3. Make sure there are no leaks using your dealer's leak detection tool. If a leak is not detected, it may be necessary to add dye to assist in locating the leak.

Is the condenser leaking?

Yes - Go to the next step.

No - This bulletin does not apply, continue with normal troubleshooting.

2. Make sure the leak is not caused by a foreign object.

There are several types of damage that can result in a leak. This bulletin is looking for leaks that are caused by the manufacturing process. Damage like those caused by foreign objects that break the tube face are not covered under this warranty extension. A foreign object may damage the fins, but as long as the tube face is not impacted, the leak will be covered under this warranty extension.

- Tube face damaged by foreign object - This bulletin does not apply, continue with normal troubleshooting.
- Foreign object damage but tube face is not damaged, or the tube face is corroded - Go to REPAIR PROCEDURE.
- No damage or corrosion found but the condenser is leaking - Go to REPAIR PROCEDURE.

**Foreign Object Damaged Tube Face
Not Covered Under Warranty Extension**

**Foreign Object Did Not Damage Tube Face
Covered Under Warranty Extension**

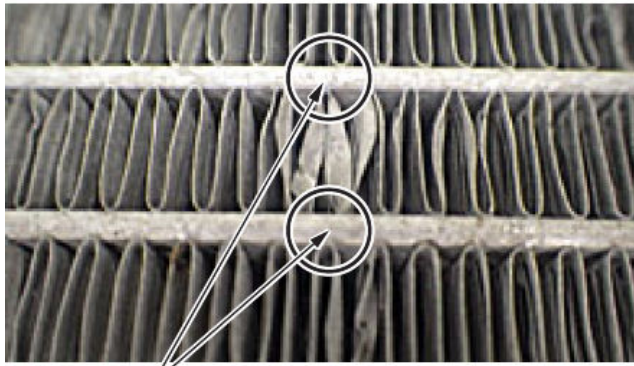

Fin damage without impact damage to the tube face.

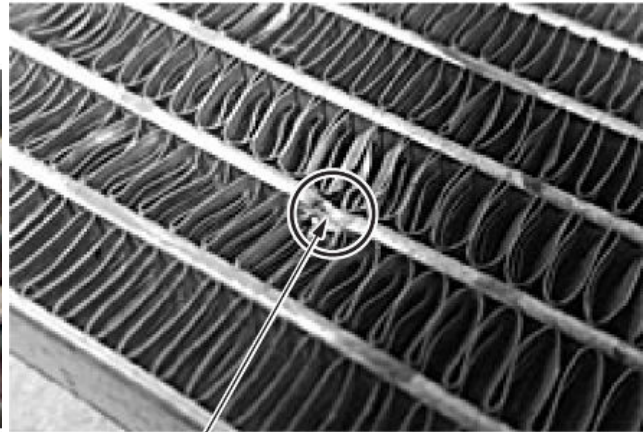

Impact damage on the tube face.

REPAIR PROCEDURE

NOTE

Make sure you review the precautions when working with the A/C system.

1. Follow the equipment manufacturer's instructions and connect the A/C recover/recycle/recharge machine to the high-pressure service port and the low-pressure service port.

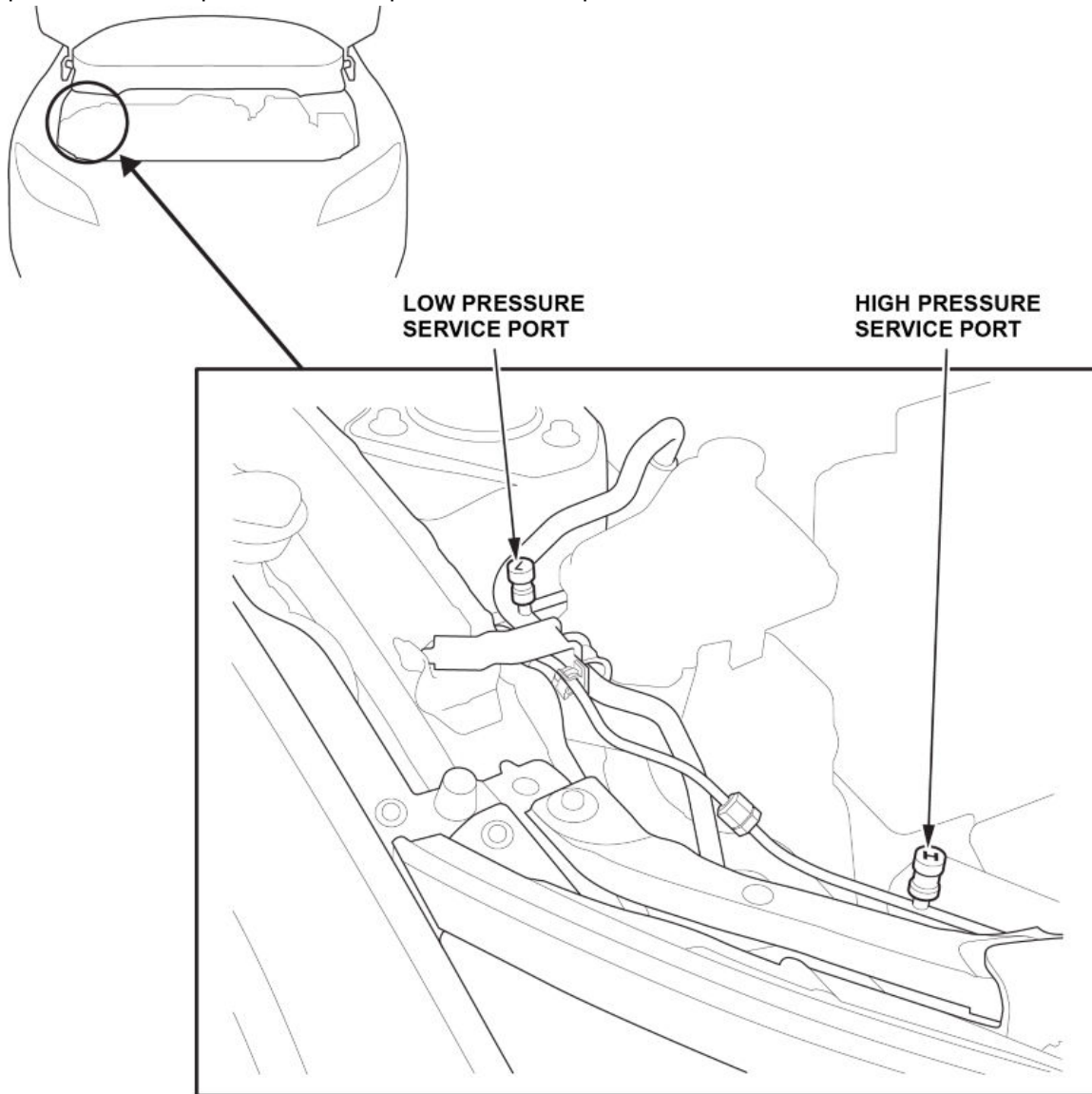

2. Recover the refrigerant from the A/C system.
3. Measure the amount of refrigerant oil removed from the A/C system after the recovery process is completed. Make sure to put the same amount of new refrigerant oil back into the A/C system before charging.

4. Remove the front grille cover.

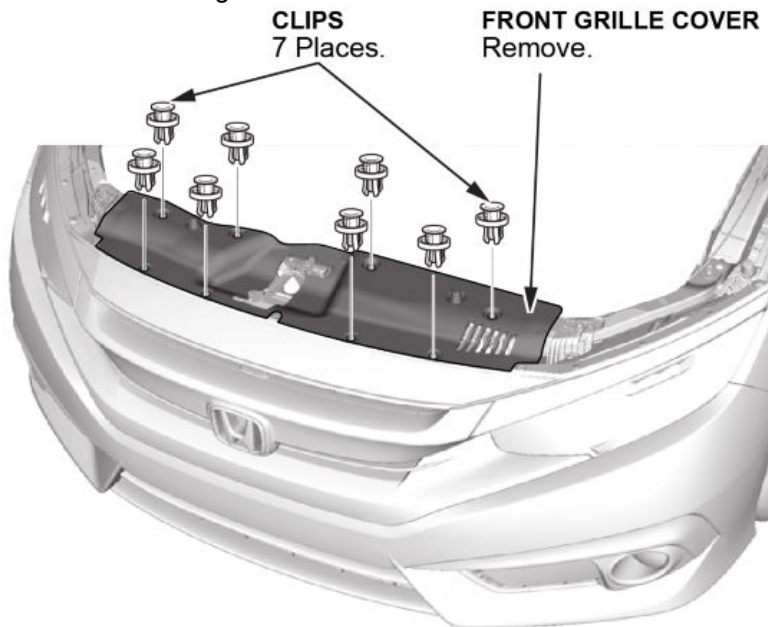

5. Remove the front bumper.

2/4 DOOR

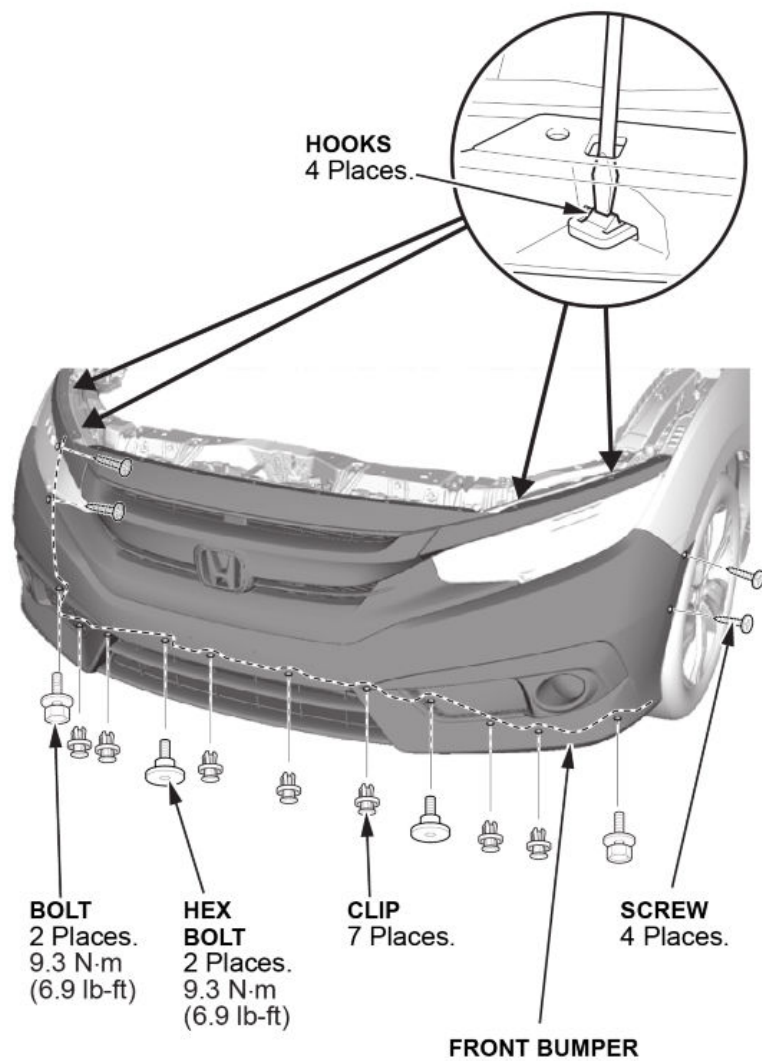

5 Door

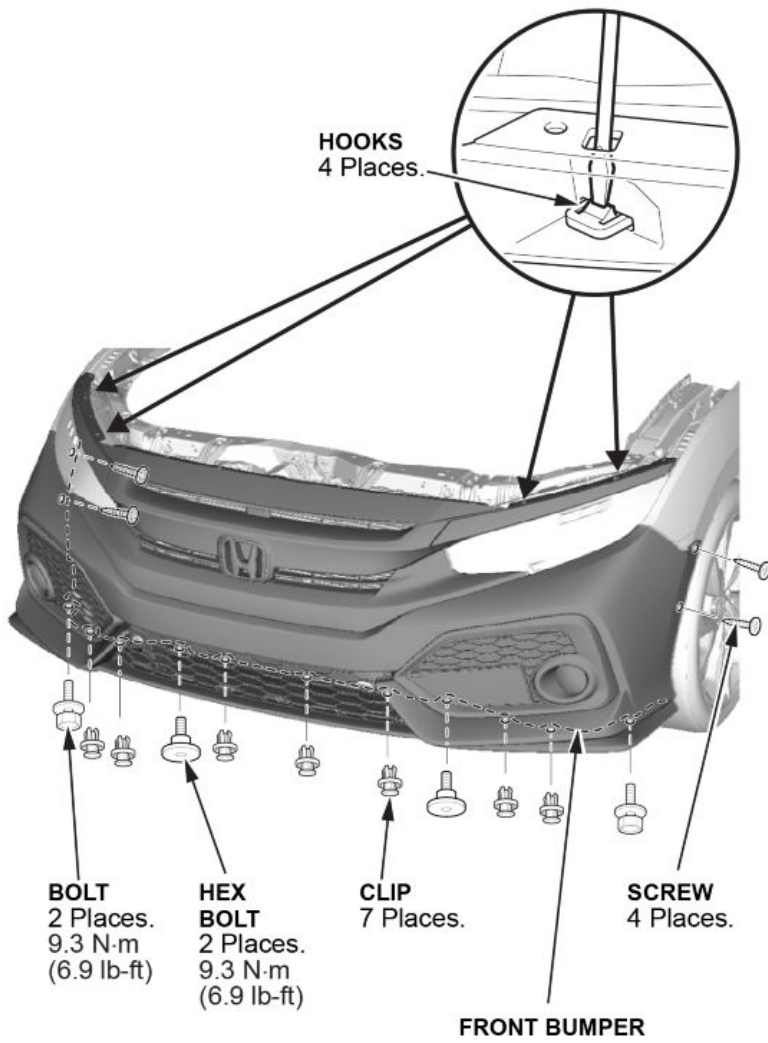

5.1. Pull the bumper out by the wheel well to release it from the hooks on the side spacer.

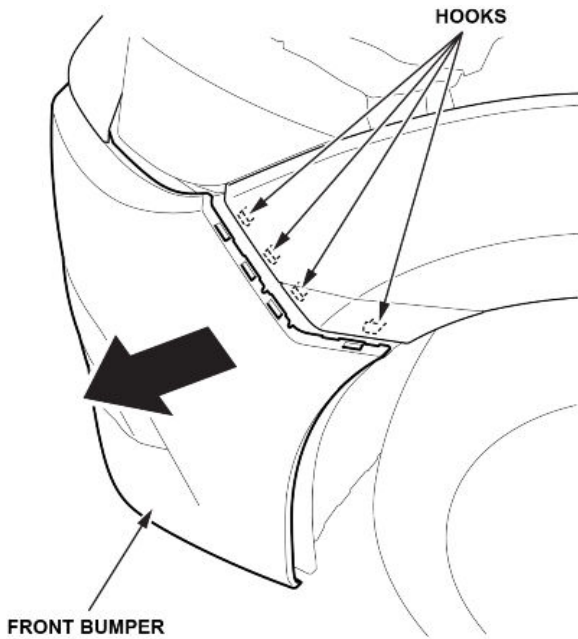

- 5.2. With the help of an assistant, pull the front bumper away from the side spacer, then release the bumper from the hooks on the upper beam.

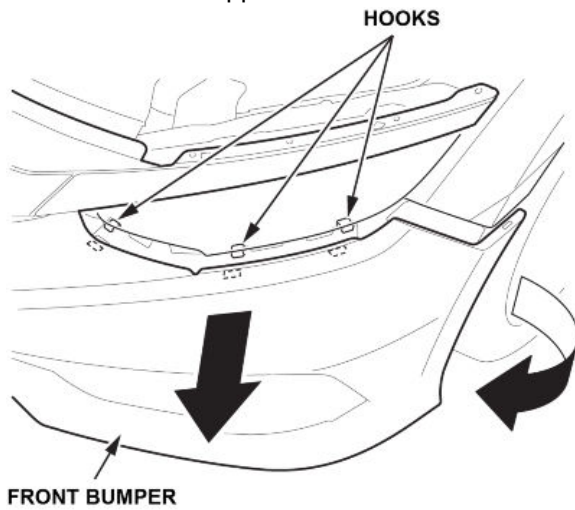

- 5.3. **With fog light only:** Disconnect the connectors.

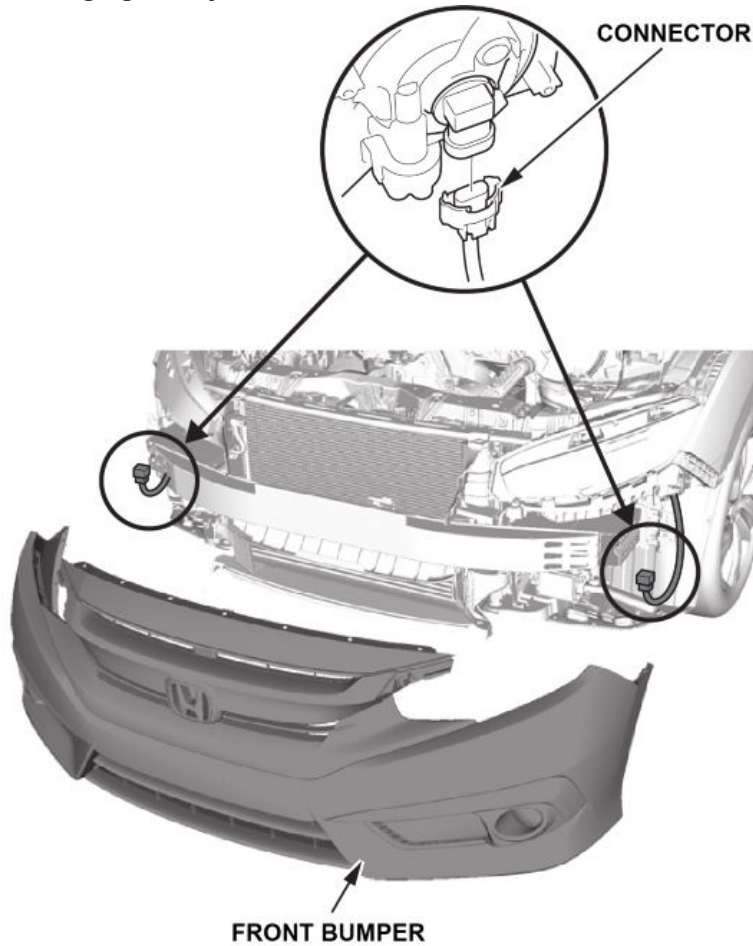

- 5.4. Remove the bumper.

6. Remove the front bumper upper beam.

1.5 L

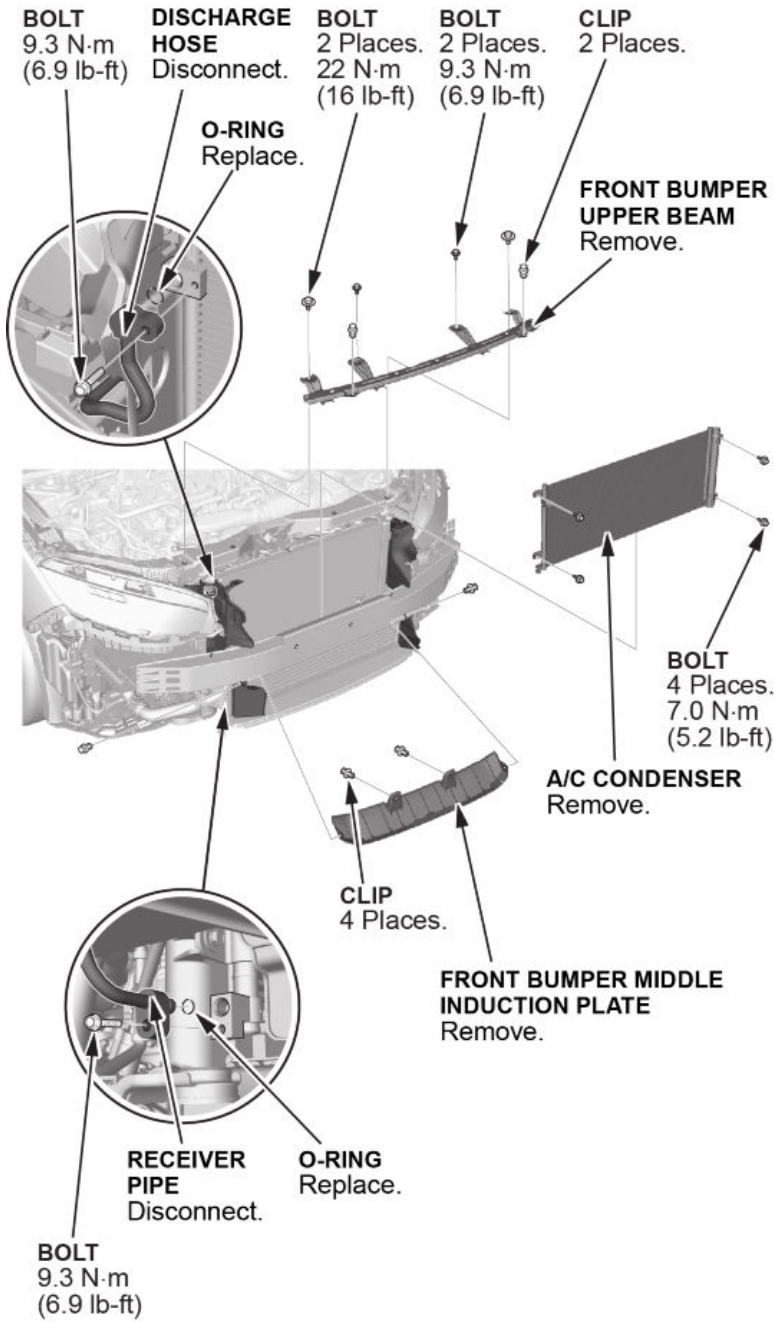

2.0 L

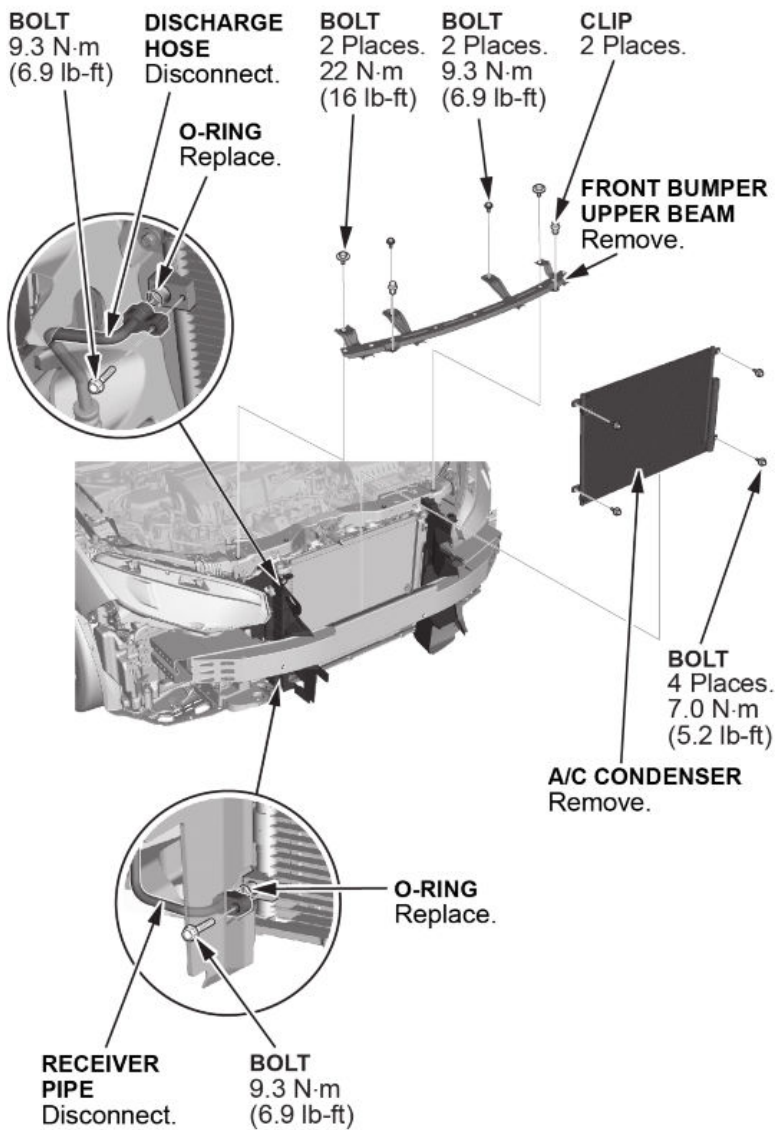

7. **With front bumper middle induction plate only:** Remove the front bumper middle induction plate.
8. Remove the discharge hose from the condenser.
9. Remove the receiver pipe from the condenser.
10. Remove the A/C condenser.
11. Install the new A/C condenser assembly.
12. Install all removed parts in the reverse order of removal.
 - Receiver pipe
 - Discharge hose
 - Front bumper induction plate (if removed)
 - Front bumper upper beam
 - Connect fog light (if disconnected)
 - Front bumper
 - Front grille cover

13. Add the necessary amount of refrigerant oil to the A/C system. Refer to *A/C Refrigerant Oil Replacement* in the service information.
14. Add the necessary amount of refrigerant to the A/C system. Refer to *A/C Refrigerant Recovery/Evacuation/Charging* in the service information.
15. Make sure there are no refrigerant leaks and the A/C system functions properly.

END