

SIEMENS

**P1 Bus Interface Module (P1 BIM)
Owner's Manual**

125-3583 April 18, 2013

April 18, 2013

NOTICE

The information contained within this document is subject to change without notice and should not be construed as a commitment by Siemens Industry, Inc. Siemens Industry, Inc. assumes no responsibility for any errors that may appear in this document.

All software described in this document is furnished under a license and may be used or copied only in accordance with the terms of such license.

WARNING

This equipment generates, uses, and can radiate radio frequency energy and if not installed and used in accordance with the instructions manual, may cause interference to radio communications. It has been tested and found to comply with the limits for a Class A digital device, pursuant to Part 15 of the FCC rules. These limits are designed to provide reasonable protection against such interference when operated in a commercial environment. Operation of this equipment in a residential area is likely to cause interference in which case users at their own expense will be required to take whatever measures may be required to correct the interference.

SERVICE STATEMENT

Control devices are combined to make a system. Each control device is mechanical in nature and all mechanical components must be regularly serviced to optimize their operation. All Siemens Industry, Inc. branch offices and authorized distributors offer Technical Support Programs that will ensure your continuous, trouble-free system performance.

For further information, contact your nearest Siemens Industry, Inc. representative.

Copyright © 2013 by Siemens Industry, Inc.

TO THE READER

Your feedback is important to us. If you have comments about this manual, please submit them to SBT_technical.editor.us.sbt@siemens.com.

CREDITS

APOGEE, APOGEE GO, InfoCenter Administrator, InfoCenter Report Manager, InfoCenter Server, InfoCenter Suite, and Insight are registered trademarks of Siemens Industry, Inc.

Other product or company names mentioned herein may be the trademarks of their respective owners.

Printed in the USA

Table of Contents

How To Use This Manual	ix
Manual Organization.....	ix
Prerequisites	ix
For Smoke Control Applications.....	x
When Using Insight Software.....	x
Manual Conventions	x
Manual Symbols	xi
Getting Help	xi
Where To Send Comments	xi
Chapter 1—Product Overview	13
Chapter Overview	13
P1 Bus Interface Module Overview	14
Product Numbers	15
General Installation Requirements	15
I/O Module Insertion Required for Proper Grounding	16
I/O Row Orientation	16
TX-I/O Network Architecture.....	17
Chapter 2—Hardware Features	19
Chapter Overview	19
P1 BIM Product Diagram (10-module).....	20
P1 BIM Product Diagram (4-module).....	21
TX-I/O Bus	22
TX-I/O Product Range	22
TX-I/O Product Range Specifications	23
TX-I/O Compatibility	24
Adds to Existing Systems	24
TX-I/O Modules.....	25
TX-I/O Module Address Keys.....	26
TX-I/O Module Product Numbers.....	28
TX-I/O Module Product Diagram.....	29
TX-I/O LCD Symbol Chart.....	31
TX-I/O Module Functions	31
TX-I/O Module Feature Summary	32
Digital Input Modules (TXM1.8D and TXM1.16D)	33

Digital Output Modules (TXM1.6R and TXM1.6R - M)	34
Universal I/O Modules (TXM1.8U and TXM1.8U - ML)	35
Super Universal I/O Modules (TXM1.8X and TXM1.8X- ML)	37
TX-I/O Power and Communication Modules	39
TX-I/O Power Supply.....	41
TX-I/O Power Supply Product Diagram	42
Bus Connection Module	43
Bus Connection Module Product Diagram.....	43
Extending Communication	43
PX Series Enclosures and Service Boxes	45
Enclosure Features	45
PX Series Service Box Features.....	46
Product Numbers	49
Enclosure and Service Box Specifications.....	49
18" Enclosure	49
19" and 34" Enclosures.....	50
PX Series Enclosure Dimensions	51
18" Enclosure	51
19" Enclosure	52
34" Enclosure	53
PX Series Enclosure Placement	54
Chapter 3—Troubleshooting	56
Chapter Overview	56
Service Information	56
Electrostatic Discharge Requirements.....	57
Ordering Replacement Parts	57
P1 BIM Troubleshooting	57
TX-I/O Module Troubleshooting.....	58
Error Status Messages	59
Reinstalling the DIN Clips	59
Glossary.....	60
Index.....	65

How To Use This Manual

This manual is written for the owner and user of Siemens TX-I/O P1 BIM and modules. It is designed to help you become familiar with the P1 BIM as used as an integral part of the TX-I/O Range.

This section covers manual organization, manual conventions and symbols used in the manual, how to access help, related publications, and other information that will help you use this manual.

Manual Organization

This manual contains the following chapters:

- *Chapter 1, Introduction* presents an overview of P1 BIM and other TX-I/O Range device operation.
- *Chapter 2, Hardware* describes the hardware components of the TX-I/O Range, including the P1 BIM, and their functions.
- *Chapter 3, Troubleshooting* describes basic corrective measures to take if you encounter a problem when using the P1 BIM and other components of the TX-I/O Range. This chapter is not intended to serve as a full diagnostic guide. Rather, it addresses basic troubleshooting issues. If you encounter a problem not covered in this section or require further assistance, consult your local Siemens representative.
- The *Glossary* describes terms and acronyms that apply to this manual.
- The *Index* helps you locate information presented in this manual.

Prerequisites

In addition to reading this owner's manual, you should also become familiar with the following Siemens technical documentation. Each document has been written to help you get the most out of your P1 BIM.

These manuals, along with information about other Siemens products, technical training classes, and services can be obtained from your local Siemens representative.

- *Powers Process Control Language (PPCL) User's Manual (125-1896)*. This manual describes Powers Process Control Language (PPCL), the language used to write the control programs for the P1 BIM.
- *APOGEE Field Panel User's Manual (125-3000)*. This manual describes the operator interface program you use to communicate with the P1 BIM and APOGEE field panels. It contains information on defining the TX-I/O Range database, including slopes and intercepts.

For Smoke Control Applications

Smoke Control Systems Application and Engineering Manual (125-1806). This manual is a comprehensive reference on smoke control applications for APOGEE and pre-APOGEE equipment. It contains all of the various agency requirements and recommended practices of organizations that are widely recognized in composing standards and testing equipment involved in life safety applications.

When Using Insight Software

See the *Insight 3.x Documentation*. To view this documentation, open the Insight Online Documentation window, which you can access from the Insight Main menu or the Insight program group.



Manual Conventions

The following table lists conventions to help you use this manual in a quick and efficient manner.

Convention	Example
Numbered Lists (1,2,3...) indicate a procedure with sequential steps.	<ol style="list-style-type: none">1. Turn OFF power to the field panel, and then turn power back ON to field panel.2. Contact your local Siemens representative.
Actions that you should perform are specified in boldface font.	Type F for Field panels. Click OK to save changes and close the dialog box.
Error and system messages are displayed in Courier New font.	The message <code>Report Definition successfully renamed</code> appears in the status bar.

Manual Symbols

The following table lists the symbols used in this Owner's Manual to draw your attention to important information.

Notation	Symbol	Meaning
WARNING:		Indicates that personal injury or loss of life may occur if you do not perform a procedure as specified.
CAUTION:		Indicates that equipment damage, or loss of data may occur if you do not perform a procedure as specified.
		Note. Highlights important and especially useful information.

Getting Help

For more information about the P1 BIM and TX-I/O Range, contact your local Siemens representative.

Where To Send Comments

Your feedback is important to us. If you have comments about this manual, please submit them to sbt_technical.editor.us.sbt@siemens.com.

Chapter 1–Product Overview

Chapter Overview

This chapter provides an introduction to the P1 BIM. The following topics are discussed:

- P1 Bus Interface Module Overview
- Product Number
- General Installation Requirements
- I/O Row Orientation
- TX-I/O Network Architecture

P1 Bus Interface Module Overview

The P1 Bus Interface Module (P1 BIM) enables communication between a P1 Field Level Network (P1 FLN) or MEC Expansion Bus, and TX-I/O modules. P1 BIM provides the TX-I/O Bus signal and 24 Vdc at 14.4W to power the TX-I/O modules and external devices such as sensors. External devices draw DC power from the 24 Vdc and ground terminals on the Super Universal I/O modules. P1 BIM also distributes fused 24Vac to external devices such as actuators. External devices draw AC power from the 24 Vac and ground terminals on the Universal and Super Universal I/O modules.

P1 BIMs reside at the top of a TX-I/O self-forming bus, which may also contain DI or DO modules, Universal modules (modules with points configurable as DI, AI, or AO), TX-I/O power supplies, or bus connection modules.

10 Module P1 BIM: Additional power supplies can be added as needed, it can support up to 80 points on a maximum of 10 modules.

4-Module P1 BIM: No additional power supplies can be added. It can support up to 64 points on a maximum of 4 modules.

See the power sizing tables in *Chapter 2 TX-I/O Power and Communication Modules*.

A controller with FLN ports or an expansion (PXM) bus, and Firmware Revision 2.8 or 3.0.1 and later (for example, an MEC 1200EFB), can therefore control and communicate with points on a TX-I/O bus that begins with a P1 BIM. All PXC Modular (with PXX-485.3), PXC Compact 36 and PXC Compact 24F can communicate with points on a TX-I/O bus that begins with a P1 BIM.



The P1 BIM is required in order to connect a TX-I/O module row to a P1 FLN or an MEC Expansion Bus. TX-I/O modules connected to a PXC Modular or PXC Compact 36 controller self-forming bus do not require a P1 BIM.

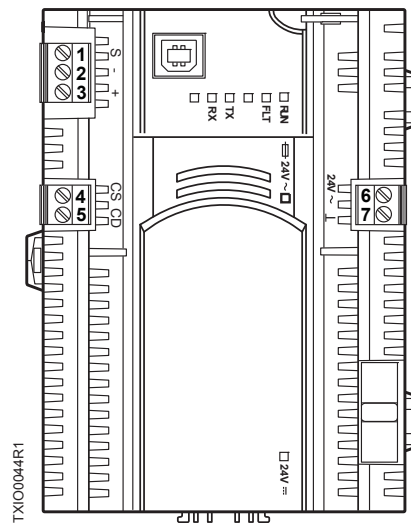

P1 Bus Interface Module Example (TXB1.P1).

Product Numbers

TXB1.P1 P1 Bus Interface Module (BIM) (10-module)

TXB1.P1-4 P1 Bus Interface Module (BIM) (4-module)

General Installation Requirements



CAUTION:

All devices not isolated by a TIE must be connected to the same or bonded power service.

System Neutral (\perp) must be connected to all devices on the TX-I/O bus, including those on separate DIN rails or in separate enclosures.



CAUTION:

Whenever the entire system is not intentionally floating, including all I/O devices or peripherals, Laptop and FLN the System Neutral is required to be grounded to the approved building earth ground at a single point only. Where multiple panels are used, the earth ground is installed in the primary panel, which houses the controller. System Neutral earth grounding is also required by NEC for Safety whenever the transformer primary is greater than 150 Vac.

I/O Module Insertion Required for Proper Grounding

All measuring/neutral terminals are connected in the plug-in I/O module, not in the terminal base. When the I/O module is removed, these terminals are not connected.

I/O Row Orientation

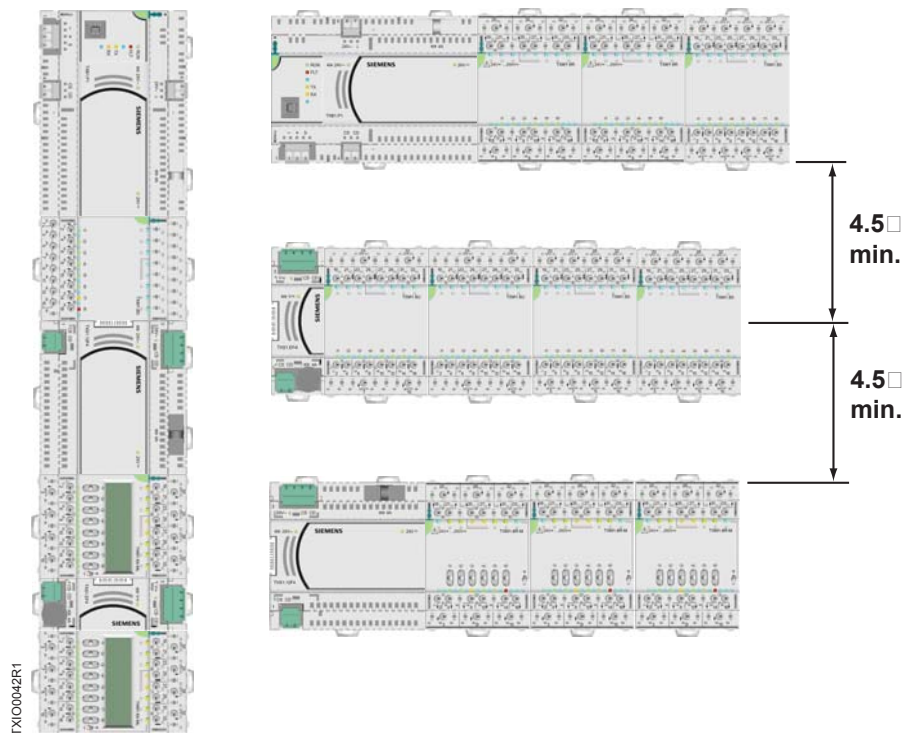

TX-I/O Orientation Options.



DIN rails must be centered a minimum of 4.5 inches from obstructions on either side (or above and below for horizontal mounting) in order to provide a 2.5 inch clearance on both sides of the modules for wires to ports and connectors. Modules can also be temporarily removed from the steel DIN rail for easier wiring.

TX-I/O Network Architecture

TX-I/O devices connected via TX-I/O Bus on a P1 BIM may reside on any APOGEE field panel P1 FLN or MEC Expansion Bus. TX-I/O may also be connected to any Compact 36 or Modular TX-I/O Bus using a TX-I/O power supply without using a P1 BIM.

P1 BIM may not be directly connected MLN, ALN or any LonWorks or BACnet MS/TP FLN.



APOGEE Field Panel Firmware Revision 2.8 (or later) for P2 or Firmware Revision 3.0.1 (or later) for BACnet/IP is required to support TX-I/O devices.

Chapter 2—Hardware Features

Chapter Overview



This chapter describes the P1 BIM and other TX-I/O Range components and functions. The following topics are discussed:

- P1 BIM Product Diagram
- TX-I/O Bus
- TX-I/O Product Range
- TX-I/O Modules
- TX-I/O Power and Communication Modules
- PX Series Enclosures and Service Boxes

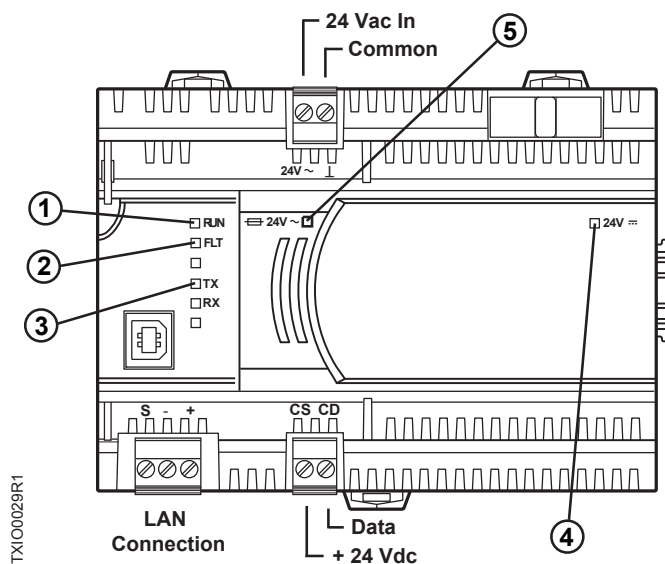
P1 BIM Product Diagram (10-module)



P1 Bus Interface Module (BIM) (10-module) Features, Symbols, and Status LEDs.

	LED, Symbol, or Feature	Status	Indication
	24V~	–	Supply voltage, 24 Vac input
	⊥	–	System Neutral
	CS	–	24 Vdc Communication Supply
	CD	–	Communication Data (Signal)
	S - +	–	FLN connection (S) signal common, (-) RS-485 signal B, (+) RS-485 signal A, shield is terminated on the enclosure ground not the P1 BIM
1	RUN (green)	ON	Lights after power-up tests OK and the BIM operating system is running
		Flashing	Address key is not inserted or is not being read correctly
2	FLT (red)	–	For future use
3	TX, RX (yellow)	Flashing	Indicates communication on the bus
4	 24V Vdc (green) Module supply/field supply voltage, 24 Vdc (conductor CS, measured on bus).	ON	24 Vac bus voltage is in the acceptable range
		OFF	24 Vac bus voltage is outside the acceptable range, indicating insufficient or shorted supply of the I/O bus, or one of the AC/DC converters is faulty
5	 24V V~ (green) Fuse LED for 24 Vac supply peripheral devices	ON	24 Vac (supply voltage) input present; fuse is intact
		OFF	No 24 Vac (supply voltage) input, or fuse is blown

P1 BIM Product Diagram (4-module)

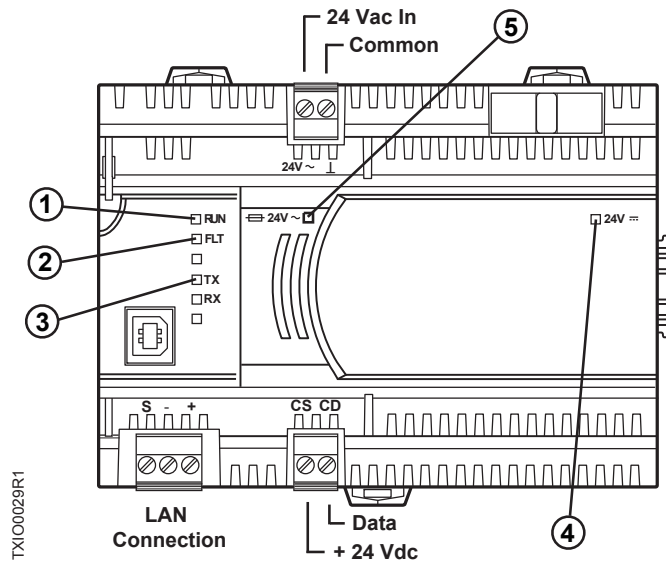

P1 Bus Interface Module (BIM) (4-module) Features, Symbols, and Status LEDs.

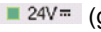
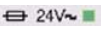
	LED, Symbol, or Feature	Status	Indication
	24V~	–	Supply voltage, 24 Vac input
	⊥	–	System Neutral
	S - +	–	FLN connection
1	RUN (green)	ON	Lights after power-up tests OK and the BIM operating system is running
2	FLT (red)	–	For future use
3	TX, RX (yellow)	Flashing	Indicates communication on the bus
4	 (green) Module supply/field supply voltage, 24 Vdc (conductor CS, measured on bus).	ON	24 Vac bus voltage is in the acceptable range
		OFF	24 Vac bus voltage is outside the acceptable range, indicating insufficient or shorted supply of the I/O bus, or one of the AC/DC converters is faulty
5	 Fuse LED for 24 Vac supply peripheral devices – TXS1.EF4 only.	ON	24 Vac (supply voltage) input present; fuse is intact
		OFF	No 24 Vac (supply voltage) input, or fuse is blown

TX-I/O Bus

The P1 BIM uses TX-I/O modules to communicate with devices in the building services plant. The modules reside on a self-forming TX-I/O bus that transmits both power and communication signals.

TX-I/O modules are modular expansion I/O consisting of an electronics module and a terminal base. The electronics modules perform A/D or D/A conversion, signal processing, and point monitoring and command output through communication with the P1 BIM. The terminal bases provide for termination of field wiring and connection of a self-forming bus.

The P1 BIM provides power for TX-I/O modules and peripheral devices. The 10-Module P1 BIM can be used in parallel with TX-I/O Power Supplies to meet the power needs of the I/O points.

- The 10-module P1 BIM supports a maximum of 80 points and 10 modules, so many installations will not require additional power.
- The 4-module P1 BIM supports a maximum of 64 points and 4 modules.
- If additional power is needed for the TX-I/O modules or sensor power, additional TX-I/O Power Supplies may be connected to the TX-I/O bus. For more information, see the *TX-I/O Power Supply* section.
- The 24 Vac supply terminals are fused (replaceable) for NEC Class 2 (24Vac at 50/60 Hz) through the P1 BIM, and F4 Versions of TX-I/O Power Supply, or Bus Connection Module. F10 Versions of TX-I/O Power Supply, or Bus Connection Module have a 10A fuse for NEC Class 1 Power Limited, but have further restrictions.
- The 24 Vdc supply terminals are connected in the Super Universal TX-I/O module, not in its terminal base. The 24 Vdc is supplied and overload protected in the TX-I/O Power Supply or P1 BIM and current-limited in the Bus Connection Module.

TX-I/O Product Range

TX-I/O is a line of I/O modules, with associated power and communication modules, for use within the APOGEE Automation System. The TX-I/O product range includes the following:

- Eight types of I/O modules, which act as signal converters. They communicate between the PXC Modular and the related devices in the building services plant.
- TX-I/O Power Supply for the TX-I/O modules.
- TX-I/O Bus Connection Module, which bridges communication and power from one DIN rail to another.
- P1 Bus Interface Module (BIM), which provides P1 FLN communication and power for TX-I/O modules. It does not contain application or control for the TX-I/O modules.

TX-I/O Product Range Specifications

Dimensions

TX-I/O Modules	2.52" L × 3.54" W × 2.75" D (64 mm L × 90 mm W × 70 mm D)
TX-I/O Power Supply	3.78" L × 3.54" W × 2.75" D (96 mm L × 90 mm W × 70 mm D)
TX-I/O Bus Connection Module	1.26" L × 3.54" W × 2.75" D (32 mm L × 90 mm W × 70 mm D)
P1 Bus Interface Module (BIM)	5" L × 3.54" W × 2.75" D (128 mm L × 90 mm W × 70 mm D)

Electrical

Power Requirements	24 Vac +/- 20% @ 50/60 Hz
--------------------	---------------------------

Power Supply	Power Output	Power Consumption
TX-I/O Power Supply	28.8 W (1.2 A at 24 Vdc)	150 VA max. (TXS1.12F4) 204 VA max. (TXS1.12F10)
P1 BIM	14.4 W (0.6 A at 24 Vdc)	125 VA max.

TX-I/O Modules	Power Consumption	24 Vdc Output Bus Voltage	24 Vac Supply Voltage
TXM1.8D	1.1 W	-	-
TXM1.16D	1.4 W	-	-
TXM1.8U	1.5 W	-	96 VA
TXM1.8U-ML	1.8 W	-	96 VA
TXM1.8X	2.2 W	4.8 W max.	96 VA
TXM1.8X-ML	2.3 W	4.8 W max.	96 VA
TXM1.6R	1.7 W	-	-
TXM1.6R-M	1.9 W	-	-

Operating Environment

Ambient operating temperature	32°F to 122°F (0°C to 50°C), 5% to 95% rh (non-condensing)
-------------------------------	---

Agency Listings

UL	UL 864 UUKL Smoke Control Equipment (TXB1.P1 Only) ULC-C100 UUKL7 Smoke Control Equipment (TXB1.P1 Only) UL 916 PAZX CSA 22.2 No. 205 PAZX7
Agency Compliance	FCC Compliance Australian EMC Framework (C-Tick) European EMC Directive (CE)

TX-I/O Compatibility

The TX-I/O Range has the following compatibility and support:

- Insight software – Revision 3.8 or later is fully compatible with the TX-I/O Range. Upgrading to Insight Revision 3.8 provides full support from the APOGEE front end and is strongly recommended.

Previous revisions of Insight software will not display the P1 BIM in System Profile, will not create the P1 BIM module report, or be able to print labels for the TX-I/O modules. In addition, backing up and restoring the field panel database will be incomplete for current output points that previously have not been software configurable.

- APOGEE P2 Firmware Revisions 2.8 and later are fully compatible with the TX-I/O Range.
- APOGEE BACnet Firmware Revisions 3.0.1 and later are fully compatible with the TX-I/O Range.
- TX-I/O is not currently supported on wireless FLNs, LonWorks, or MS/TP networks.
- Customer Tools – Datamate Advanced 3.8 supports the TX-I/O Range. The Point Editor, Report Builder, and Report Viewer applications support the TX-I/O Range.

Adds to Existing Systems

Due to the backwards compatibility provided through the use of P1, TX-I/O modules can be added to existing systems. The P1 BIM and attached TX-I/O modules may reside on existing MEC expansion buses and existing P1 FLNs. Field panel firmware and Insight software upgrades will be required.

TX-I/O Modules

TX-I/O modules provide I/O points for the APOGEE Automation System based upon TX-I/O Technology. TX-I/O Technology provides flexibility of point types, tremendous flexibility of signal types and support for manual operation. The modules reside on a self-forming TX-I/O bus that transmits power as well as communication signals.

The design of the TX-I/O modules provides optimum diagnostics and results in a more efficient installation and maintenance workflow.

- Field wiring may be terminated prior to installation of electronics.
- Connected peripheral devices can be measured without affecting or being affected by the I/O module.
- Hot-swappable electronic components allow powered electronics to be disconnected and replaced without removing terminal wiring or disturbing the self-forming bus.

All TX-I/O modules provide the following features:

- DIN rail mounting.
- High density point count (compared to physical dimensions).
- Hardware addressed with address keys.
- Terminal base and plug-in I/O module electronics, which can be easily separated.
- Removable label holder that allows for customized point labels.
- LEDs that provide status indication and diagnostic information for the I/O module, as well as for each point on the module.
- Connection terminals. I/O module terminal base allows for wiring on the field device side; there is no need for separate terminal strips.

TX-I/O Module Address Keys

NOTE: The 10-module P1 BIM uses address keys to set the address. The 4-module P1 BIM uses the USB.

The TX-I/O address keys must be inserted, seated, and closed correctly in order to function.

1. Remove the address key from the strip.

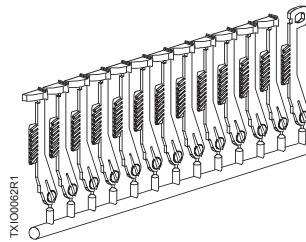

2. Align the slot in the base of the key with the module and push the key in until it clicks in place.

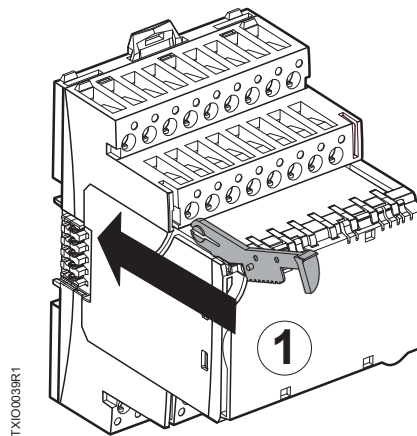

3. Rotate the key into position on the module.

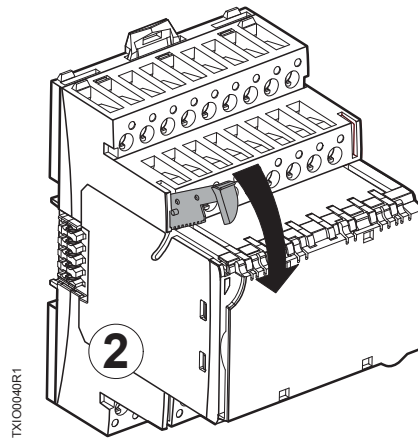

TXI00040R1

TX-I/O Module Product Numbers

Modules

TXM1.8D	8 digital input points. Monitors status signals from normally open (NO) or normally closed (NC), latched voltage free/dry contacts.
TXM1.16D	16 digital input points. Monitors status signals from normally open (NO) or normally closed (NC), latched voltage free/dry contacts.
TXM1.6R	6 digital output points. NO or NC (form C), maintained or pulsed, voltage free/dry contacts.
TXM1.6R-M	6 digital output points. NO or NC (form C), maintained or pulsed, voltage free/dry contacts. Equipped with manual override switches.
TXM1.8U	8 points, which can be individually configured as digital input, analog input, or analog output.
TXM1.8U-ML	8 points, which can be individually configured as digital input, analog input, or analog output. Equipped with a local override/identification device (LOID), which includes an LCD signal display.
TXM1.8X	8 points, which can be individually configured as digital input, analog input, or analog output. Provides analog input and output current (4–20 mA) and 24 Vdc supply voltage for sensors.
TXM1.8X-ML	8 points, which can be individually configured as digital input, analog input, or analog output. Provides analog input and output current (4–20 mA) and 24 Vdc supply voltage for sensors. Equipped with a local override/identification device (LOID), which includes an LCD signal display.

Accessories

TXA1.K12	Two sets of address keys, numbers 1 – 12.
TXA1.K24	One set of address keys, numbers 1 – 24.
TXA1.K-48	One set of address keys, numbers 25 – 48.
TXA1.K-72	One set of address keys, numbers 49 – 72.
TXA1.LLT-P100	Label paper, 100 sheets per package.
TXA1.LH	Replacement label holders.

TX-I/O Module Product Diagram

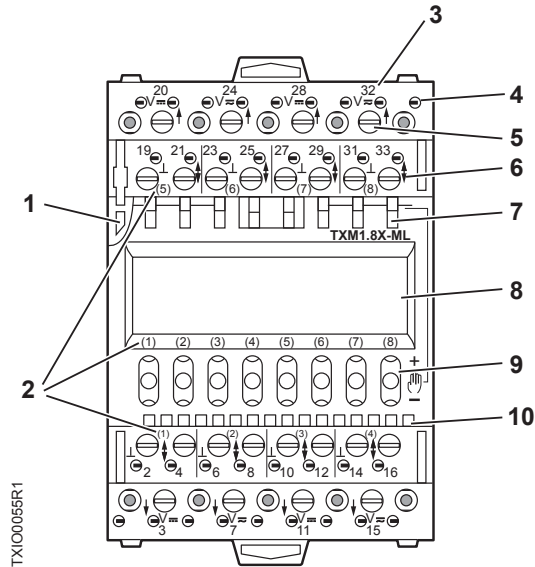



TXIO0055R1

TX-I/O Module Symbols and Status LEDs.

	LED, Symbol, or Feature	LED or Symbol	Indication
1	Address key and module status LED (green) Shows the module status as a whole (as opposed to the I/O points).	ON	24 Vac (supply voltage) input present; fuse is intact
		OFF	No 24 Vac (supply voltage) input, or fuse is blown
		Flashing or pulsing	<ul style="list-style-type: none"> • Fault indication • No address key
2	I/O point numbers	—	—
3	Terminal number	—	—
4	Test point	—	—
5	Connection terminals	—	—
6	Signal designation	⊥	System Neutral
		↕	Configurable point
		↗	Output (arrow pointing OUT from center of module)
		↖	Input (arrow pointing IN toward center of module)

TX-I/O Module Symbols and Status LEDs.

	LED, Symbol, or Feature	LED or Symbol	Indication
			24 Vdc output (field supply)
			24 Vac output (field supply)
7	Override status LEDs (yellow) When lit, indicates that a local override is active.	ON	Manual operation
		OFF	No voltage or manual operation off
		Flashing or pulsing	<ul style="list-style-type: none"> • Override action • Remote override • Output: Local override is off; operation is not possible • Input: Operation is not possible
8	LCD display (if present)	–	–
9	Local override switch (if present)	–	–
10	I/O status LEDs (green) Indicates the status of the inputs and outputs (peripheral devices). The LEDs are labeled with the I/O point number.	ON	Binary value indication
		OFF	No voltage or binary value indication
		Flashing or pulsing	<ul style="list-style-type: none"> • Fault indication • Activity of field devices • Module unconfigured, no address key • Analog value indication

TX-I/O LCD Symbol Chart

The Configured Signal Type displays with either a Signal Value that matches the signal type, or any one of the Errors, Reminders indicators.

Configured Signal Type		Signal Value	Errors, Reminders
Digital input, N/O contact		NO (contact inactive) NC (contact active)	Above range limit
Digital input, N/C contact		NO (contact active) NC (contact inactive)	Below range limit
Pulse input, N/O contact		N/A	Open circuit
Pulse input, N/C contact			Short circuit
Counter input		Step indicator	Illegal action (manual override)
Measuring input, voltage		High value (voltage, current, resistance)	No Input signal (current)
Measuring input, current		Low value (voltage, current, resistance)	Insecure (or no) output signal
Measuring input (resistance)		Low value (voltage, current, resistance)	Insecure general
Measuring input (temperature)		Temperature (Ni, Pt, NTC sensor)	I/O point inactive
Analog output, voltage		Low value (voltage or current)	Invalid process value
Analog output, current		High value (voltage or current)	Unconfigured
Unconfigured		N/A	

TX100057R1

TX-I/O Module Functions

The following TX-I/O modules are available:

- 8 point DI module (TXM1.8D)
- 16 point DI module (TXM1.16D)
- 6 point DO with Relay module (TXM1.6R)
- 6 point DO with Relay and Manual Override module (TXM1.6R-M)
- 8 point Universal module (TXM1.8U)
- 8 point Universal with Local Override/Identification Device (LOID) module (TXM1.8U-ML)
- 8 point Super Universal module (TXM1.8X)
- 8 point Super Universal with LOID module (TXM1.8X-ML)

TX-I/O Module Feature Summary

The I/O modules act as signal converters. They communicate between the field panel (via the P1 BIM or MEC Expansion Bus) and the related devices in the building services plant.



CAUTION:

Active inputs and outputs are permitted on the same module when connected sensors are powered from that module. When sensors are externally powered, active inputs and outputs should be on separate modules.

		Module Name and Product Number							
		TXM1. 8X-ML	TXM1. 8X	TXM1. 8U-ML	TXM1. 8U	TXM1. 8D	TXM1. 16D	TXM1. 6R-M	TXM1. 6R
Function		8 Super Universal		8 Universal		8 DI	16 DI	6 DO Relay	
General	Local Override	•		•				•	
	LCD Display	•		•					
DI	Static Contact (NC/NO)	•	•	•	•	•	•		
	Pulse accumulator	•	•	•	•	•	•		
	25 Hz Counter (with debouncing)	•	•	•	•				
	10 Hz Counter (with debouncing)					•	• ^a		
AI	NI 1000 LS	•	•	•	•				
	PT 1000 385	•	•	•	•				
	PT 1000 375	•	•	•	•				
	NTC 10K (w/o diode)	•	•	•	•				
	NTC 100K	•	•	•	•				
	0–10 Vdc	•	•	•	•				
	4–20 mA	•	•						
AO	0–10 Vdc	•	•	•	•				
	4–20 mA	• ^b	• ^b						
DO	ON/OFF							•	•
	Pulse ON							•	•

a. 10 Hz counter functionality is available only on point terminations 1 – 8.

b. 4–20 mA functionality is available only on point terminations 5 – 8.

The I/O module terminal bases provide the connection terminals for wiring on the field device side; therefore, there is no need for separate terminal strips.

The I/O modules on a DIN rail row receive their power from a TX-IO Power Supply, P1 BIM, or Bus Connection Module.

Digital Input Modules (TXM1.8D and TXM1.16D)

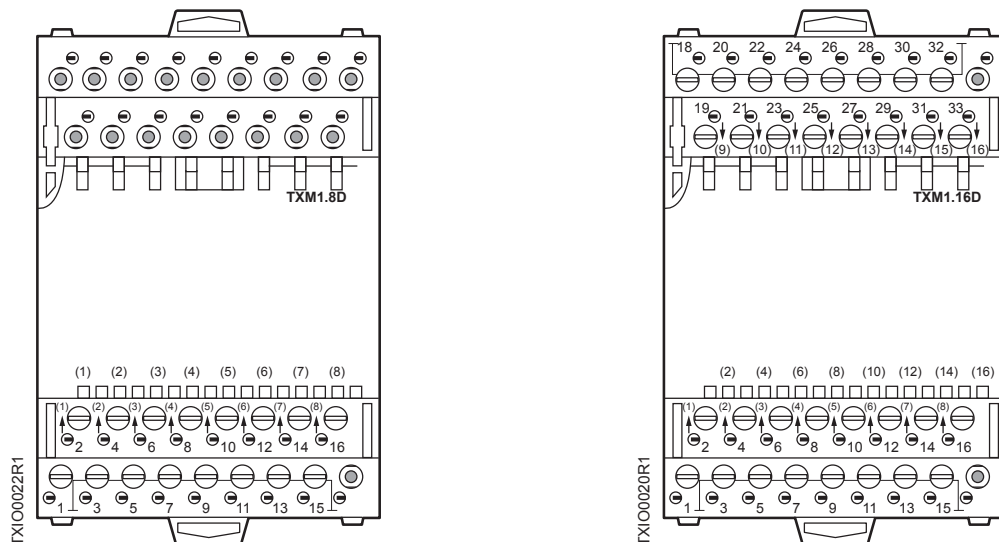

The TXM1.8D and TXM1.16D are dedicated to monitoring, respectively, 8 and 16 digital input points.

- They monitor status signals from normally open (NO) or normally closed (NC), latched voltage free/dry contacts.
- All 8 points on the TXM1.8D module, as well as 8 of the 16 points on the TXM1.16D module, may be used as pulse counters up to 10 Hz.
- Each input point has a green LED for status indication.

Digital Input Grounding Connections

The neutral of a digital input (on Digital Input, Universal and Super Universal modules) can be connected to any neutral terminal on the same module. Several digital inputs can also share a neutral terminal on the same module.

Digital Output Modules (TXM1.6R and TXM1.6R - M)

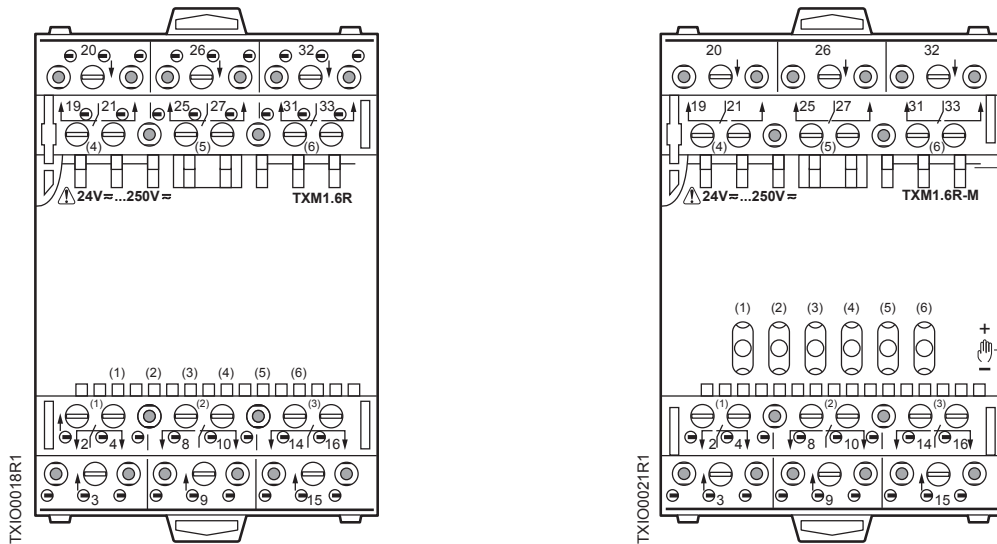

The TXM1.6R and TXM1.6R-M Digital Output modules provide six NO or NC (form C), maintained or pulsed, voltage free/dry contacts.



CAUTION:

Digital Output contacts are not internally current limited or protected against transients. If needed, externally install an NEC approved current limiting device, Metal Oxide Varistor (MOV), or both. See the MOV table in the *APOGEE Wiring Guidelines for Field Panels and Equipment Controllers (125-3002)*.

- Common terminals are not internally connected. The contacts are rated for a maximum of 250 Vac at 4A resistive or 3A inductive.
- Each I/O point has a green LED for status indication.
- The TXM1.6R-M module is also equipped with manual override switches. An orange LED per override switch indicates override status individually per point.

Digital Output Common Connections

Digital output common is isolated for each relay and must be externally wired to other DO common if needed.

Universal I/O Modules (TXM1.8U and TXM1.8U - ML)

The TXM1.8U and TXM1.8U-ML universal I/O modules provide 8 points, which can be individually configured as digital input, analog input, or analog output to best meet the specific application needs.

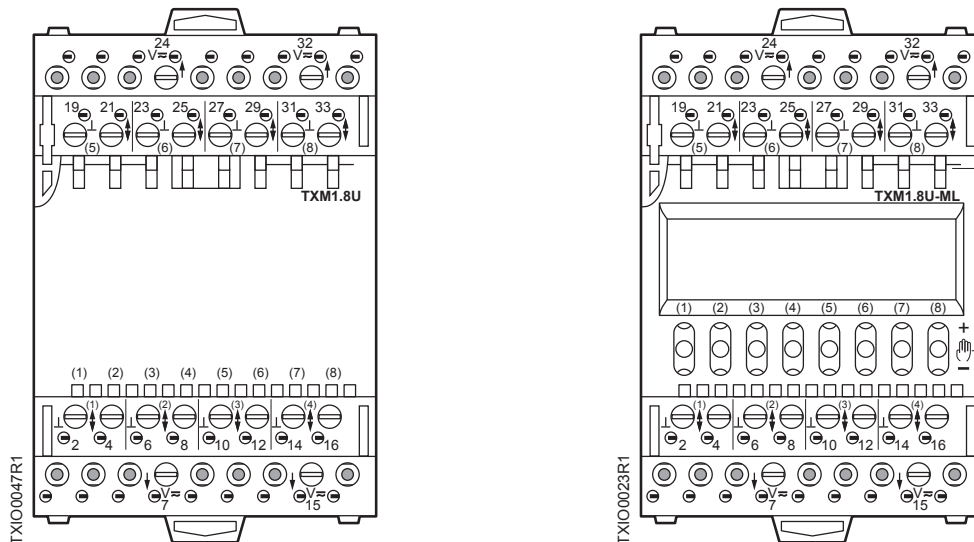

All Universal I/O modules provide:

- AC supply voltage for peripheral devices such as valves and actuators.
- Green LED status per I/O point that varies in intensity according to the voltage and current (directly proportional).

Supply Terminal Connections

- With analog inputs and outputs, the neutral must always be connected to the terminal associated with that I/O point.
- All supply terminals are connected in the I/O module, not in the terminal base.

Digital Input Grounding Connections

The neutral of a digital input (on Digital Input, Universal and Super Universal modules) can be connected to any neutral terminal on the same module. Several digital inputs can also share a neutral terminal on the same module.

Input Support

Digital input support includes voltage free/dry contacts and pulse counters up to 20 Hz.

Analog input sensor support includes:

- 1k Nickel – Landis & Gyr curve
- 1k Platinum – 375 and 385 coefficient
- 10k and 100k Thermistor – Type II Curve

Active Input and Output Support

Active input and output support includes analog input and output (0 – 10 Vdc).



CAUTION:

Active inputs and outputs are permitted on the same module when connected sensors are powered from that module. When sensors are externally powered, active inputs and outputs should be on separate modules.

Local Override/Identification Device

TXM1.8U-ML modules are also equipped with a local override/identification device (LOID, which includes an LCD signal display. The LCD displays the following information for each IO point:

- Configured signal type
- Symbolic display of process value
- Notification of faulty operation, short circuit, or sensor open circuit

Orange LEDs indicate override status individually per point.

Super Universal I/O Modules (TXM1.8X and TXM1.8X- ML)

The TXM1.8X and TXM1.8X-ML Super Universal I/O modules provide 8 points, which can be individually configured as digital input, analog input, or analog output to best meet the specific application needs.

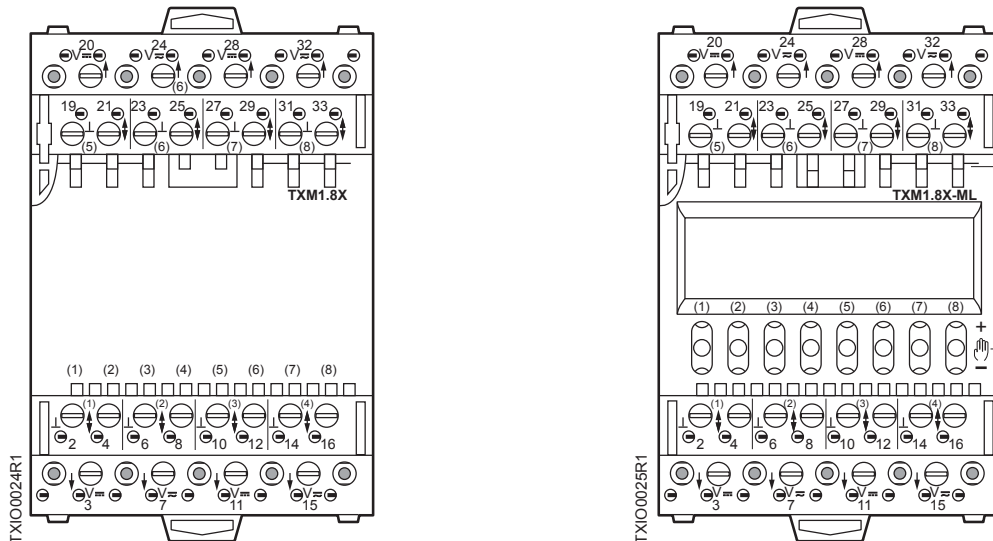

4 to 20 mA current handling capability is available on points 1 through 4 (AIs only) and points 5 through 8 (AIs or AOs).

Power consumption of analog points is included in the power consumption of the 8X module. Power consumption of other approved uses of supply voltage (for example, 1000 series RTS supply) must also be subtracted from the available 24 Vdc power provided by the P1 BIM.

All Super Universal I/O modules provide:

- AC supply voltage for peripheral devices such as valves and actuators.
- Green LED status per I/O point that varies in intensity according to the voltage and current (directly proportional).

Supply Terminal Connections

- With analog inputs and outputs, the neutral must always be connected to the terminal associated with that I/O point.
- All supply terminals are connected in the I/O module, not in the terminal base.

Digital Input Grounding Connections

The neutral of a digital input (on Digital Input, Universal and Super Universal modules) can be connected to any neutral terminal on the same module. Several digital inputs can also share a neutral terminal on the same module.

Input Support

Digital input support includes voltage free/dry contacts and pulse counters up to 20 Hz.

Analog input sensor support includes:

- 1k Nickel – Landis & Gyr curve
- 1k Platinum – 375 and 385 coefficient
- 10k and 100k Thermistor – Type II Curve

Active Input and Output Support



CAUTION:

Active inputs and outputs are permitted on the same module when connected sensors are powered from that module. When sensors are externally powered, active inputs and outputs should be on separate modules.

Active input and output support includes the following:

- Analog input and output (0 – 10 Vdc)
- Analog input current 4 – 20 mA
- Analog output current 4 – 20 mA (four current outputs maximum per module on Points 5 through 8)
- 24 Vdc supply voltage for sensors at a maximum of 200 mA per module

Local Override/Identification Device

TXM1.8X-ML modules are also equipped with a local override/identification device (LOID), which includes an LCD signal display. The LCD displays the following information for each IO point:

- Configured signal type
- Symbolic display of process value
- Notification of faulty operation, short circuit, or sensor open circuit

Orange LEDs indicate override status individually per point.

TX-I/O Power and Communication Modules

The P1 Bus Interface Module, TX-I/O Power Supplies, and Bus Connection Modules provide power and communications for the TX-I/O modules.

Product	Function		
	TX-I/O Bus Communication	24 Vdc power	24 Vac power
P1 Bus Interface Module (10-module) (TXB1.P1)	Protocol translation	14.4W at .6A Power sharing with up to three TX-I/O Power Supplies	<ul style="list-style-type: none"> • Pass-thru Output fused at 4A • NEC Class 2 96 VA max. (Output) • Class 1 Power Limited 125 VA max. (Input)
P1 Bus Interface Module (4-module) (TXB1.P1-4)	Protocol translation	14.4W at .6A	<ul style="list-style-type: none"> • Pass-thru Output fused at 4A • NEC Class 2 96 VA max. (Output) • Class 1 Power Limited 125 VA max. (Input)
TX-I/O Power Supply (TXS1.12F4) ^a	Signal pass-thru	28.8W at 1.2A	<ul style="list-style-type: none"> • Pass-thru Output fused at 4A • NEC Class 2 96 VA max. (Output) • Class 1 Power Limited 150 VA max. (Input)
TX-I/O Power Supply (TXS1.12F10) ^b	Signal pass-thru	28.8W at 1.2A	<ul style="list-style-type: none"> • Pass-thru Output fused at 10A • NEC Class 1 150 VA max. (Output) • Class 1 Power Limited 204 VA max. (Input)
Bus Connection Module (TXS1.EF4) ^a	Signal pass-thru	Pass-thru	<ul style="list-style-type: none"> • Pass-thru Output fused at 4A • NEC Class 2 96 VA max. (Output and Input)
Bus Connection Module (TXS1.EF10) ^b	Signal pass-thru	Pass-thru	<ol style="list-style-type: none"> 1. Pass-thru Output fused at 10A 2. NEC Class 1 150 VA max. (Output and Input)

a. May be used for Smoke Control installations with Smoke Control Listed Enclosures and transformers or service boxes. The line to the 24 Vac input transformer must not exceed 1000 VA. NEC Class 2 wiring may be used up to 96 VA, and NEC Class 1 Power Limited wiring must be used above 96 VA and up to 1000 VA.

b. Do not use for Smoke Control installations. The line to the 24 Vac input transformer must not exceed 250 VA. Total load provided through all 24 Vac terminals on a module must not exceed 150VA (6A).



All installations with more than one DIN rail require either a Bus Connection Module or TX-I/O Power Supply for transferring power to each additional DIN rail.

TX-I/O Power Supply

The TX-I/O Power Supply generates 24 Vdc at 28.8W to power TX-I/O modules and peripheral devices. It can also bridge communication and power from one DIN rail to another. TX-I/O Power Supply may be used with 10-module P1 BIM, but not with 4-module P1 BIM.

- An LED provides an indication of 24 Vdc on the TX-I/O bus.
- Up to three TX-I/O Power Supplies and a 10-module P1 BIM can be operated in parallel, with a maximum of two power sources per DIN rail. The 4-module P1 BIM cannot be operated with another power supply in parallel.
- All installations with more than one DIN rail require either a Bus Connection Module or TX-I/O Power Supply at the start of each additional DIN rail. The devices can be located either within a row of TX-I/O modules or at the beginning of a new DIN rail.
 - When added to an existing DIN rail, the TX-I/O Power Supply provides additional 24 Vdc power to the modules in that row.
 - When added as the first module on a new DIN rail, the TX-I/O Power Supply bridges the communication bus from one DIN rail to another and provides 24 Vdc power to the additional modules on that DIN rail.

The TX-I/O Power Supply performs the following functions:

- Provides an input point to pass additional 24 Vac (\approx) at 96 or 150 VA to peripheral devices, such as actuators.
- Routes CS (+24 Vdc Communication Supply) and CD (Communication Data signal) between DIN rails.
- Isolates the 24 Vac peripheral device supply in case of overload or short-circuit. The replaceable AC fuse can be accessed from an installed module.
- Indicates the AC fuse status with an LED for easy diagnostics.

TX-I/O Power Supply Product Diagram

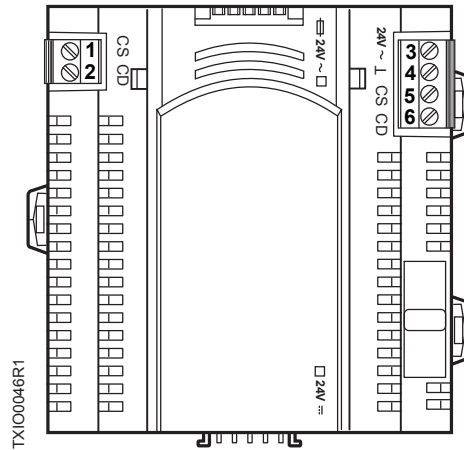

TX-I/O Power Supply Features, Symbols, and Status LEDs.

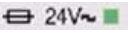
LED, Symbol, or Feature	Status	Indication
24V~	–	Supply voltage, 24 Vac input
⊥	–	System Neutral
CS	–	24 Vdc Communication Supply
CD	–	Communication Data (Signal)
 24V≡ (green)	ON	24 Vdc bus voltage is in the acceptable range
Module supply/field supply voltage, 24 Vdc (conductor CS, measured on bus).	OFF	24 Vdc bus voltage is outside the acceptable range, indicating insufficient or shorted supply of the I/O bus, or one of the AC/DC converters is faulty
	ON	24 Vac (supply voltage) input present; fuse is intact
Fuse LED for 24 Vac supply peripheral devices.	OFF	No 24 Vac (supply voltage) input, or fuse is blown

Bus Connection Module

The Bus Connection Module bridges communication and power from one DIN rail to another. Bus Connection Module may be used with either 10-module or 4-module P1 BIM.

All installations with more than one DIN rail require either a Bus Connection Module or TX-I/O Power Supply at the start of each additional DIN rail. The devices can be located either within a row of TX-I/O modules or at the beginning of a new DIN rail.

The Bus Connection Module performs the following functions:

- Provides an input point to pass additional 24 Vac (\sim) at 96 or 150 VA to peripheral devices, such as actuators.
- Routes CS (+24 Vdc Communication Supply) and CD (Communication Data signal) between DIN rails.
- Isolates the 24 Vac peripheral device supply in case of overload or short-circuit. The replaceable AC fuse can be accessed from an installed module.
- Indicates the AC fuse status with an LED for easy diagnostics.

Bus Connection Module Product Diagram

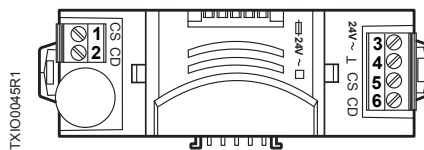

Bus Connection Module Features, Symbols, and Status LEDs.

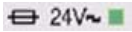
LED, Symbol, or Feature	Status	Indication
24V~	–	Supply voltage, 24 Vac input
⊥	–	System neutral
CS	–	24 Vdc Communication Supply
CD	–	Communication Data (Signal)
	ON	24 Vac (supply voltage) input present; fuse is intact
Fuse LED for 24 Vac supply peripheral devices.	OFF	No 24 Vac (supply voltage) input, or fuse is blown

Extending Communication

If an installation requires more than one DIN rail, connect the Communication Supply (CS) and Communication Data (CD) terminals from the Bus Connection Module or P1 Bus Interface Module (BIM) to the CS and CD terminals on the first device of every additional DIN rail (either a TX-I/O Power Supply or Bus Connection Module).

TX-I/O Power Supplies and Bus Connection Modules include a second set of CS and CD contacts to simplify connection of additional DIN rails. Ensure that the system neutral is installed.



CAUTION:

If wires go between enclosures or are in an enclosure with a VFD or other large motors, then use twisted pair cables and keep them a minimum of two feet away from any high voltage wires.

System Neutral (\perp) must be continuous throughout the TX-I/O Bus.



CAUTION:

The System Neutral (\perp) must be grounded at the transformer secondary neutral whenever:

- The entire system, including all I/O devices or peripherals, is not intentionally floating. This requires a laptop on battery power and isolated FLN.
- Transformer primary is greater than 150 Vac. This is an NEC Safety requirement.

For more information see the *APOGEE Wiring Guidelines for Field Panels and Equipment Controllers* (125-3002).

PX Series Enclosures and Service Boxes

PX Series enclosures house both electronic and pneumatic components. The enclosures include a perforated backplane for mounting PXC Series field panels or other electronic or pneumatic components.

Enclosure Features

- Availability in three sizes to match installation needs: 18-, 19-, and 34-inch.
- Sturdy construction, which accommodates secure conduit fittings and protects components against incidental contact and falling dirt.
- UL Smoke Control listed for indoor use (19- and 34-inch enclosures only).
- Multiple knockouts along the top and bottom.
- Perforated backplane, which extends wall-to-wall for mounting of additional equipment.
- Spacious interior for easy routing and termination of wiring.
- The 18-inch enclosure is a pull-box type utility cabinet for low cost installations. It is equipped with the following:
 - Factory-installed 16" × 12" perforated panel
 - DIN rail and wire tie bar kit
- The 19- or 34-inch PX series enclosures are equipped with the following:
 - Factory-installed backplane assembly, which includes wire tie down rails and DIN rails
 - Label pouch
 - Hinged door and key lock
 - Conduit knockouts and venting

PX Series Service Box Features

The PX Series Service Box Assemblies transform either 115 Vac or 230 Vac to 24 Vac sized for either 192 VA or 384 VA.

- The 192 VA service boxes mount directly inside a 19- or 34-inch PX Series Enclosure.
- The 384 VA service boxes provide additional power for larger systems and mount only in the 34-inch PX Series Enclosure.

The service boxes provide protection against electrical transients and are Smoke Control and Energy Management listed when installed according to the *Service Box Assemblies Installation Instructions* (553-131).

The service box assemblies consist of the following:

- Chassis for mounting inside enclosure.
- ON/OFF circuit breaker for transformer.
- Two Class 1 power limited 24 Vac outputs, which include one terminal for earth ground for use inside enclosure only.
- One Class 2 output with circuit breaker to distribute up to 96 VA for use outside the enclosure.
- Wire cover for field connections.
- Duplex Service Outlet (115 Vac models only).
- Optional sidewall kits PXA-SW192VA and PXA-SW384VA may be used for installation in third-party enclosures, such as motor control cabinets.

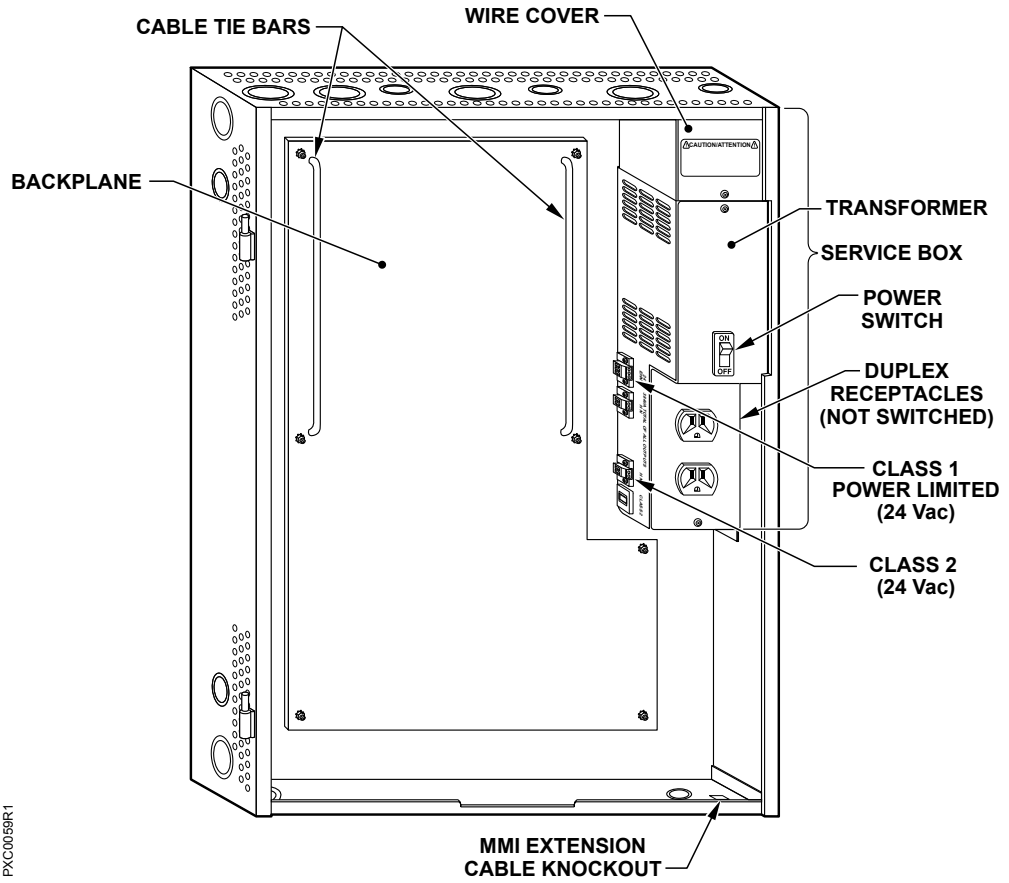

PXC0059R1

PX Series Service Box (115V), 34-inch enclosure.

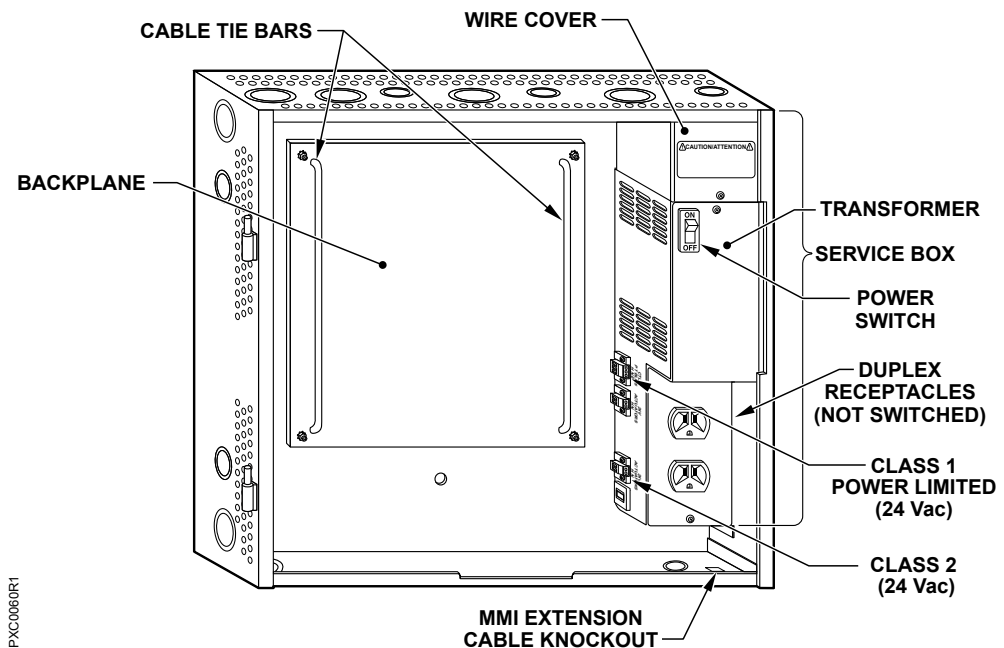

PX Series Service Box (115V), 19-inch enclosure.

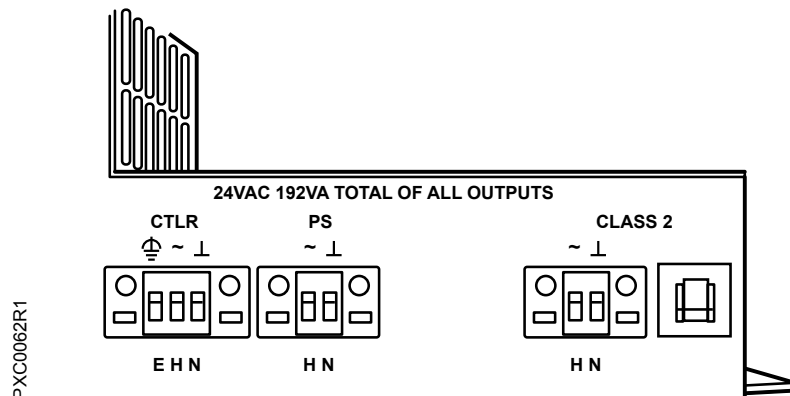

PX Series Service Box Connectors.

- Each Service Box distributes the total 24 Vac power provided to the plug-in terminations on the left side.
 - Two Class 1 power-limited terminations distribute up to the total power to controllers and power supplies inside the same enclosure.
 - Earth ground is provided on the CTLR termination.
 - One Class 2 termination distributes up to 96 VA to auxiliary devices outside of the enclosure.
- Each 115VAC Service Box has a duplex outlet on the front to power accessory devices such as modems and Portable Operator's Terminals.

Product Numbers

Controller Range

PXA-ENC18	18" PX Series Enclosure
PXA-ENC19	19" PX Series Enclosure
PXA-ENC34	34" PX Series Enclosure

Accessories

PXA-SB115V192VA	SERVICE BOX 115V, 24VAC, 192VA
PXA-SB115V384VA	SERVICE BOX 115V, 24VAC, 384VA
PXA-SB230V192VA	SERVICE BOX 230V, 24VAC, 192VA
PXA-SB230V384VA	SERVICE BOX 230V, 24VAC, 384VA
PXA-ENC19.REPL.DR	Replacement door for 19" PX series enclosure
PXA-ENC34.REPL.DR	Replacement door for 34" PX series enclosure
PXA.ENC.PAINT	PX series enclosures touch-up paint

Enclosure and Service Box Specifications

18" Enclosure

Dimensions

PXA-ENC18	18" H × 14" W × 6" D (457.2 mm × 355.6 mm × 152.4 mm) UL Listed NEMA Type 1 Enclosure, Pull-box style
-----------	---

Operating Environment

Ambient operating environment	+32°F to +122°F (0°C to +50°C) 95% rh (non-condensing)
-------------------------------	---

Mounting Surface	Building wall or structural member
------------------	------------------------------------

Agency Listings

Agency Compliance	UL 508A FCC Compliance
-------------------	---------------------------

19" and 34" Enclosures

Dimensions

PXA-ENC19	19" H × 22" W × 5.75" D (482.6 mm × 558.8 mm × 146.05 mm) UL Listed NEMA Type 1 Enclosure, Hinged Door with Lock
-----------	--

PXA-ENC34	34" H × 22" W × 5.75" D (863.6 mm × 558.8 mm × 146.05 mm) UL Listed NEMA Type 1 Enclosure, Hinged Door with Lock
-----------	--

Operating Environment

Ambient operating environment	+32°F to +122°F (0°C to +50°C) 95% rh (non-condensing)
-------------------------------	---

Mounting Surface	Building wall or structural member
------------------	------------------------------------

Agency Listings

UL	UL 864 UUKL Smoke Control Equipment ULC-C100 UUKL7 UL 916 PAZX UL 508A
----	---

Agency Compliance	FCC Compliance Australian EMC Framework - with metal enclosure, maximum opening size is 34" European EMC Directive (CE) - with metal enclosure, maximum opening size is 34" European Low Voltage Directive (LVD)
-------------------	---

Service Box Electrical

Power Requirements	115 Vac Service Box 115 Vac @ 50/60 Hz, ±15% Vac, ±5% Hz, 200 VA maximum protected by 15A circuit breaker 230 Vac Service Box 230 Vac @ 50/60 Hz, ±15% Vac, ±5% Hz, 200 VA maximum protected by 10A circuit breaker
--------------------	--

Service Box 24 Vac Output	Total output: 175 VA, with a maximum output of 60 VA from the 24V Actuators (Class 2) connector.
---------------------------	--

PX Series Enclosure Dimensions

18" Enclosure

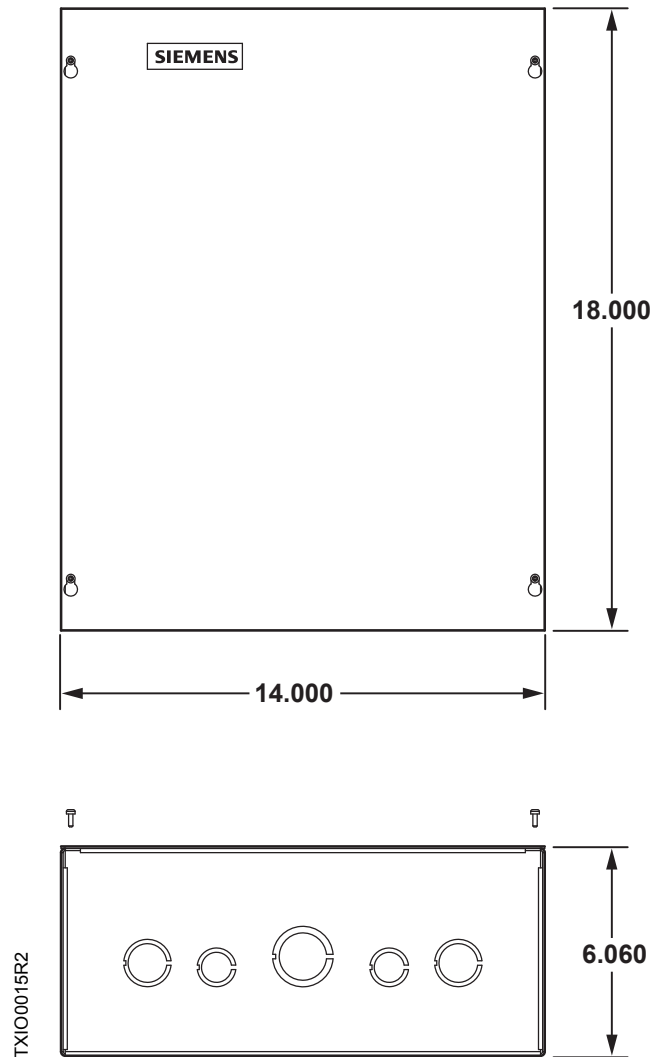

19" Enclosure

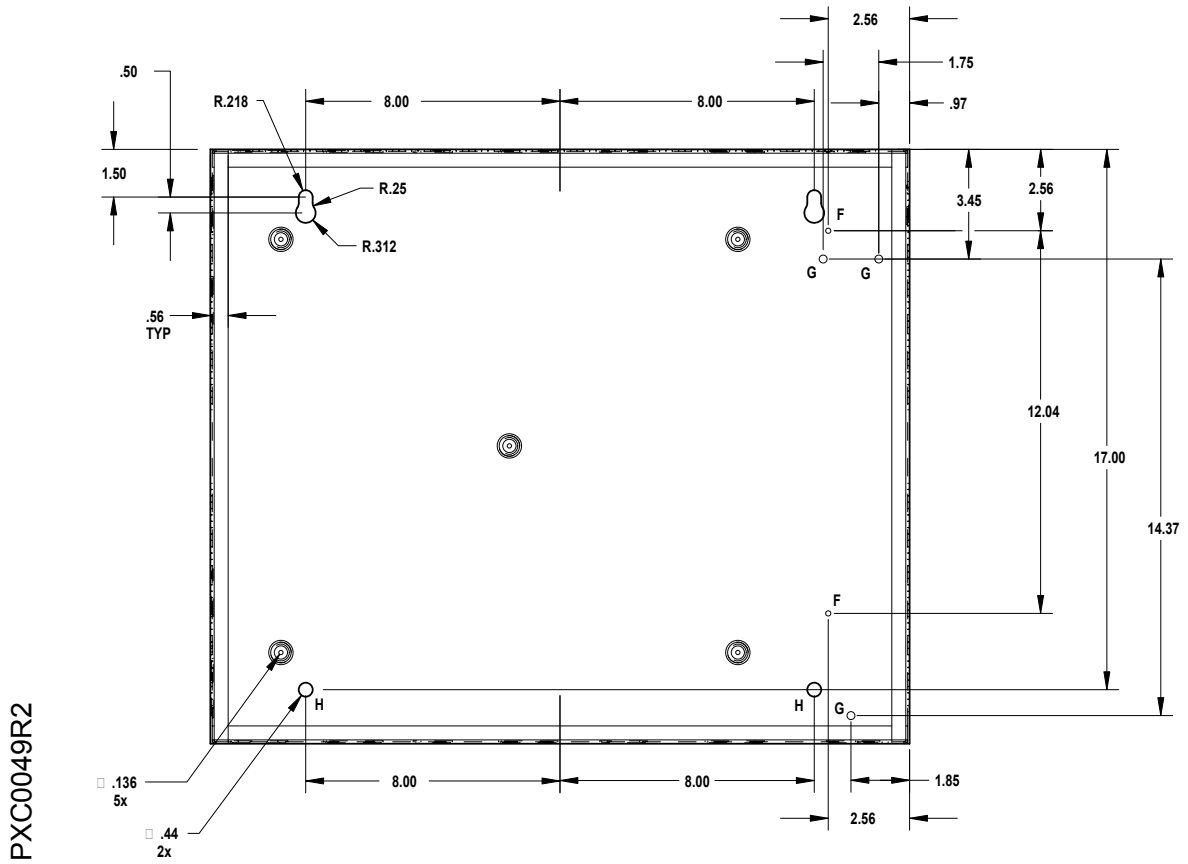

PXC0049R2

34" Enclosure

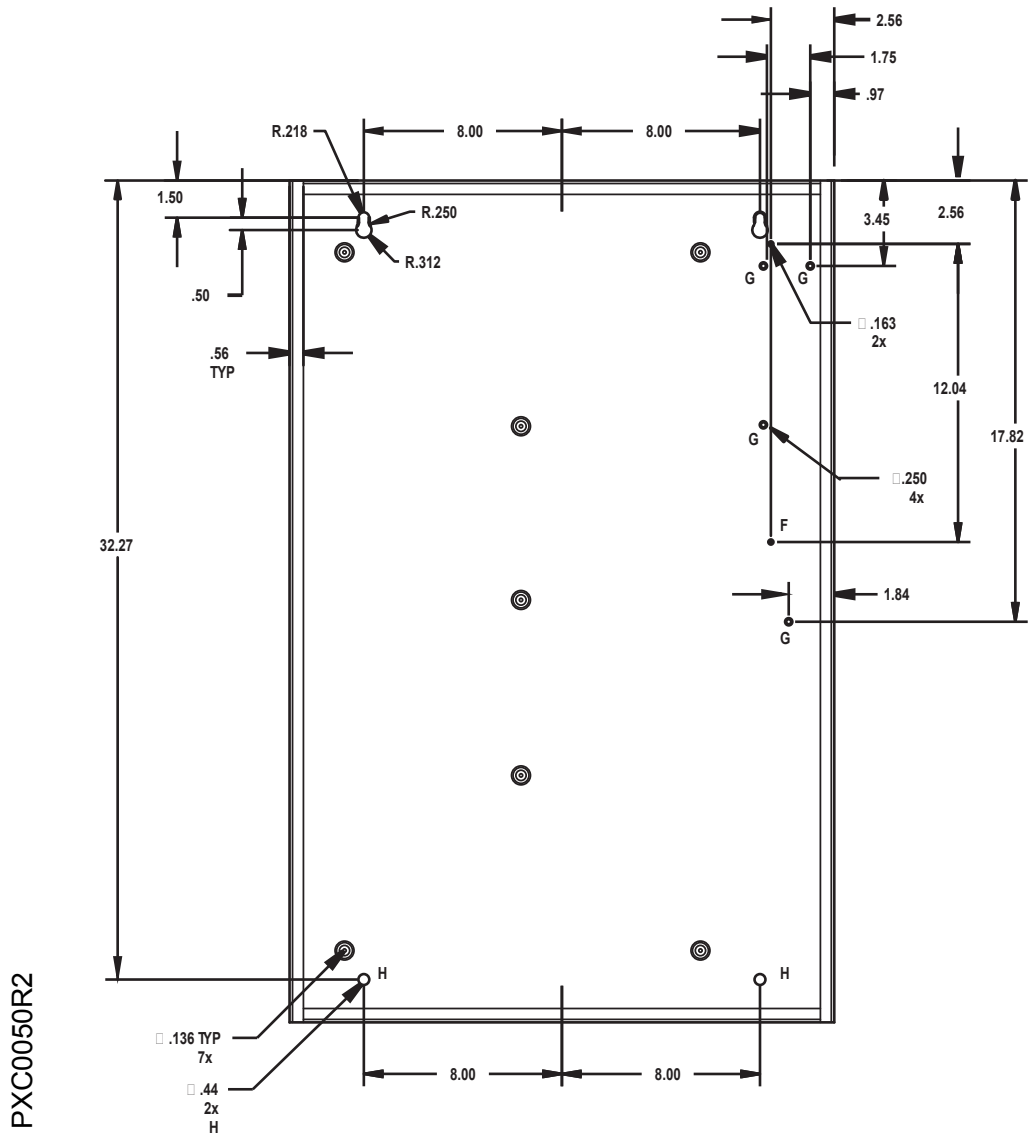

PX Series Enclosure Placement



CAUTION:

Enclosure must be mounted on a non-vibrating surface, at least 12 feet (3.7 m) away from radio equipment and 5 feet (1.5 m) from large motors or VFD.

Under no circumstances should the enclosure be mounted on ductwork or HVAC equipment.

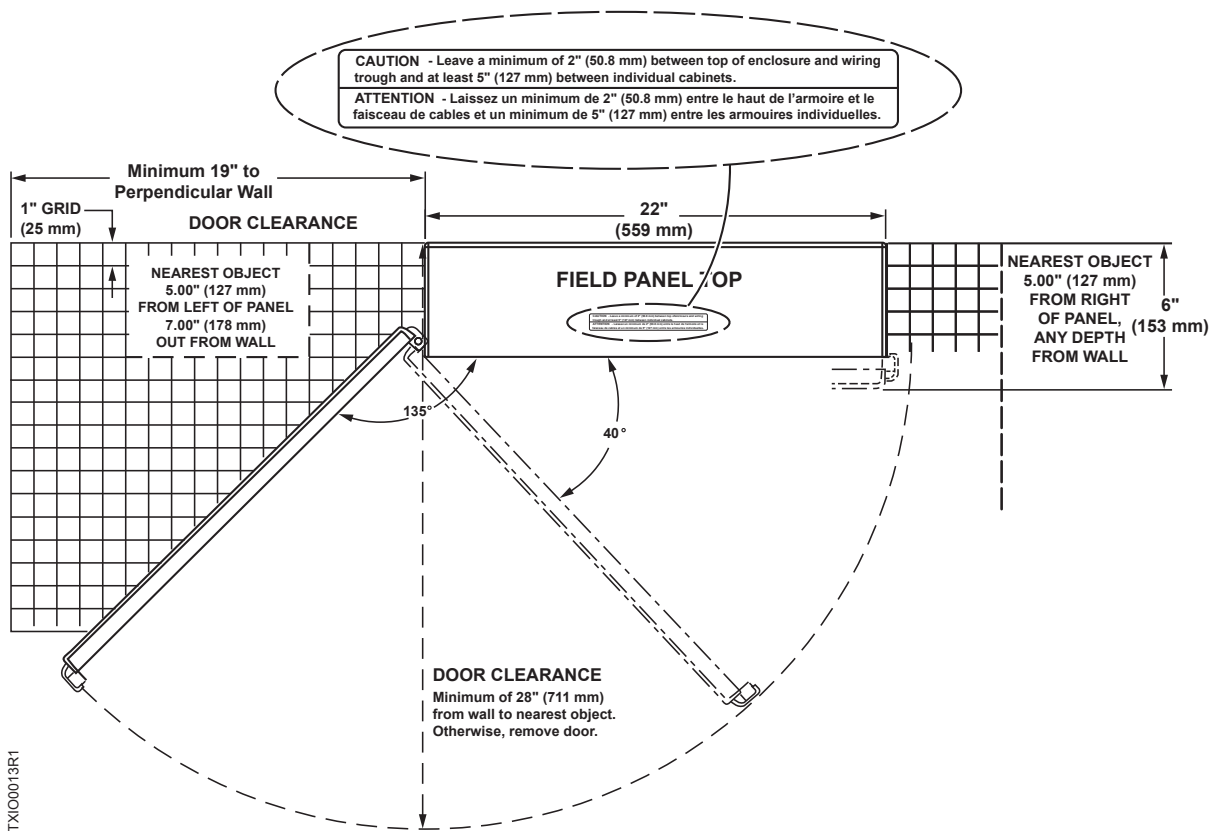

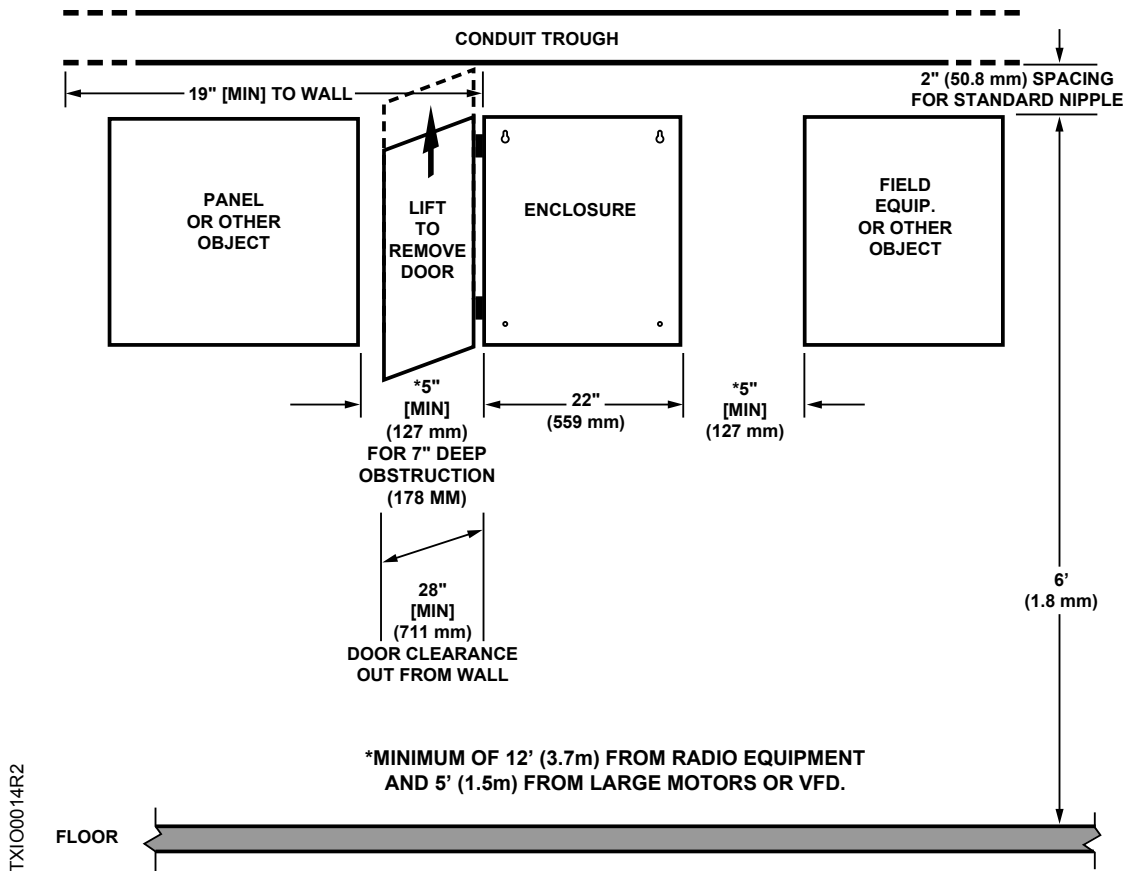

- Space between door panel and opening obstruction must be at least 11 inches (279.4 mm) to allow for door removal at 40 degrees, or 28 inches (711 mm) with a cabinet mounting at least 19 inches (483 mm) from the left side wall to allow door to completely open at 135 degrees.
- Minimum spacing between the panel and any left (hinged side) obstruction is 1 inch spacing for every 1 inch of depth, starting at 5 inches (127 mm) to the left.
- Minimum spacing between the panel and any right (lock side) obstruction is 5 inches (127 mm) to the right at any depth.

Chapter 3–Troubleshooting

Chapter Overview



The following information is for qualified service personnel only.

This chapter describes corrective measures you can take if you have a problem with a P1 BIM or TX-I/O module. The following topics are discussed:

- Service Information
- Electrostatic Discharge Requirements
- Ordering Replacement Parts
- P1 BIM Troubleshooting
- TX-I/O Module Troubleshooting
- Error Status Messages
- Reinstalling the DIN Clips

If you encounter a problem not covered in this manual or the problem cannot be fixed with the following procedures, contact your local Siemens representative.

Service Information

To determine if the P1 BIM is powered up and communicating properly, verify that the RUN LED is ON (see the *P1 BIM Product Diagram* section). The RUN LED is on solid during normal operation.



When troubleshooting, record the problem and what actions were performed immediately before the problem occurred. Being able to describe the problem in detail is important should you need assistance from your local Siemens representative.

When removing power to a P1 BIM to perform maintenance or service, make sure that the person in charge of the facility is aware of this and that appropriate steps are taken to keep the building in control.

To view the status of the P1 BIM and to call up reports for troubleshooting, you can use an operator's terminal and the operator interface or an Insight workstation.

For more information, see the following documentation:

- *APOGEE Field Panel User's Manual (125-3000).*
- *Insight 3.8.1 or Later Documentation.* To view Insight documentation, see the Insight Online Documentation window, which you can access from the Insight Main Menu or the Insight program group.

Electrostatic Discharge Requirements

An electrostatic discharge (ESD) wrist strap is generally not required when installing or servicing a P1 BIM. However, if it is installed in a very dry environment where a high static discharge is likely, an ESD wrist strap is recommended.

Ordering Replacement Parts

If a P1 BIM or TX-I/O module is not operating correctly, it should be replaced. Contact your local Siemens representative for ordering and replacement information.

P1 BIM Troubleshooting

Also see the *P1 BIM Product Diagram* section for additional information on the LEDs.

P1 BIM RUN LED is ON solid.

The P1 BIM RUN LED is steadily lit during normal operation to indicate that 24 Vac power is ON and the application firmware has booted.

P1 BIM RUN LED is flashing.

1. Verify that the address key is inserted.
2. If the address key is inserted, but not being read correctly, contact your local Siemens representative.

P1 BIM FLT LED is ON solid or flashing.

1. Power down the module
2. Wait 30 sec
3. Power on the module
4. If the condition persists, contact your local Siemens representative.

P1 BIM RUN LED and 24V~ LED are OFF.

1. If power is ON, verify that the application firmware has booted in about 10 seconds.
2. Verify that power is connected.
3. Check the service box and transformer ON switches.
4. Measure the voltage on 24V~ and ⊥ (Terminals 1 and 2) and if they are not between 20 and 30 Vac, correct the voltage.

P1 BIM RUN LED is ON, but the 24V~ LED is OFF.

- Remove any shorts on the V~ terminals and replace the fuse.

P1 BIM 24V= LED is OFF.

1. Remove any shorts on the V= terminals and cycle power to the P1 BIM.
2. Rotate the key and set the TX-I/O modules in a parked position, one at a time, until the P1 BIM 24V= LED turns ON, and then replace the module that caused the short.

TX-I/O Module Troubleshooting

Analog input/output points displayed at operator's terminal of the PXC Modular are not reading as expected.

1. Verify that all slope/intercept entries are correct.
2. Verify that the sensor is functioning properly. Contact your local Siemens representative if the sensor requires replacement.

Points cannot be read or commanded from the operator's terminal at the PXC Modular.

1. Verify that failed points have been properly addressed.
2. Verify the status of the points at the operator's terminal. Verify that points are not under operator priority.

LAI point does not function properly or appears as failed (*F*) on the display.

1. Verify that the field input device is within range.
2. Verify that the voltage supplied to the device is correct, as in a 4 to 20 mA device.
3. Verify that points are properly terminated on the termination board.

LAO point does not function properly or appears as failed (*F*) on the display. The output does not change when commanded.

1. Verify that the device connected to the point is functioning properly and is not shorted out.
2. Verify that points are properly terminated on the termination board.
3. Verify that the voltage supplied to the device is correct.

Analog Input reads out of range.

Verify that the slope/intercept settings are correct.

Error Status Messages

For error status messages, see the *APOGEE Field Panel User's Manual* (125-3000).

Reinstalling the DIN Clips

Do the following to reinstall a DIN clip:

1. Place the wire spring clip into the pocket in the channel for the DIN clip.
2. Make sure the mounting tab is face down.
3. Working from the center (inside) of the base, slide the DIN clip into the channel for the tab. (See the following figure.)



The end with the screw hole slides into the channel first.

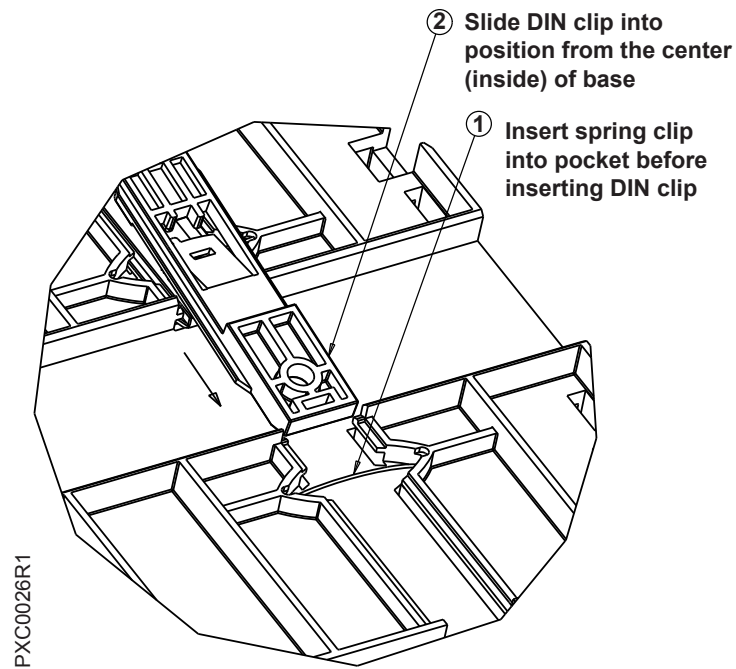

Reinstalling a DIN Clip.

Glossary

alarm priority

Ranking of a point alarm.

analog input-electric

Physical analog input point that receives either a current, voltage, or resistance input signal.

analog output-electric

Physical analog output point that generates a voltage signal.

analog output-pneumatic

Physical analog output point that outputs a voltage signal to a transducer module, which outputs a pneumatic signal.

Automation Level Network (ALN)

Field panel (Protocol 2, Ethernet, or BACnet/IP) network consisting of PXC Modular Series, MBCs, RBCs, PXC Compact Series, MECs, and FLN Controllers. BACnet/IP ALNs may also contain Insight BACnet/IP-capable workstations and third-party BACnet devices. The Automation Level Network (ALN) and Building Level Network (BLN) are identical. Product documentation may refer to these networks as ALN, BLN, or ALN/BLN.

BACnet

A data communication protocol for Building Automation and Control Networks, ANSI/ASHRAE Standard 135-2004. BACnet allows devices from multiple manufacturers to work together on a network.

BACnet/IP

BACnet over IP protocol.

Building Level Network (BLN)

The Building Level Network (BLN) is now called the Automation Level Network (ALN). However, at this time, all firmware prompt strings continue to use the BLN abbreviation.

command priority

Ranking of a point command.

current value

Last commanded or sensed value of a logical point.

Device port

A USB Device port supports a generic serial interface for an HMI or Tool connection.

digital input

Physical input point indicating contact closure, without electrical potential (dry contact), either as an open or closed state or as an accumulation of state changes.

digital output

Physical output point consisting of 1 Form C (SPDT) relay connecting a common terminal with either normally open or normally closed terminals.

digitized value

Integer value used by the field panel to determine the logical value, state, and condition of logical points.

dynamic point information

Information stored in the point database that may change during system operation and is not part of the data entered when defining points.

enclosure

Metal case that houses the field panel components.

English units

The foot-pound-second system of units for weights and measurements.

enhanced alarming

Application that allows floating alarms and alarm segregation.

Field Level Network (FLN)

To more closely reflect current technology, the Floor Level Network (FLN) is now called the Field Level Network. Data communications link that passes information between an FLN device or devices and an Automation Level Network (ALN) device. Unitary Controllers (UC) and Terminal Equipment Controllers (TEC) are examples of FLN devices.

field panel

ALN device controlling the FLN to which the P1 BIM is connected. The logical point database for physical points in a TX-I/O module, connected to a P1 BIM, resides in a field panel.

HAND-OFF-AUTO (HOA) switches

Manually operated control switches located on the face of HOA equipped TX-I/O modules (TXM1.8U-ML, TXM1.8X-ML, TXM1.6R-M) that enable digital output points to be manually placed into HAND (ON), OFF, or AUTO control. Analog outputs can be placed into AUTO and 10 manual control positions.

Human-Machine Interface (HMI) port

To more closely reflect current technology, the Man-Machine Interface (MMI) port is now called the Human-Machine Interface (HMI) port. However, at this time, all firmware prompt strings continue to use the MMI abbreviation.

point condition

State of a point such as normal, alarm, alarm-by-command, failed, operator disabled, or proofing.

service box

Component that receives the line power and converts it to 24 Vac for the field panel.

text-based terminal

Operator terminal that displays and accepts text only.

totalized value

Sum of information (in hours or minutes) about logical points such as run time, total volume, and degree days.

Transmission Control Protocol/Internet Protocol (TCP/IP)

Protocol suite developed by the U.S. Department of Defense to link dissimilar computers across different kinds of networks. TCP/IP is the transport protocol employed by the Internet and is commonly used on Ethernet networks.

unbundle

Describes the action of entering a point that resides in an equipment controller's database into the field panel's database so that it can be monitored and controlled from the field panel.

Index

A

accessories	24
active input and output support.....	32, 34
address keys	
inserting	23
part numbers	24
agency listings	
enclosures and service boxes	42–43
TX-I/O product range.....	21

B

backwards compatibility	21
Bus Connection modules	
description	38
diagram.....	38
functions	35
product numbers.....	38
specifications	20
symbols and LEDs.....	38

C

common connections	30
compatibility	21

D

Digital Input modules.....	29
Digital Output modules.....	30
dimensions	
enclosure diagrams	44–46
enclosures and service boxes	42–43
TX-I/O product range.....	20
DIN clips, reinstalling.....	52
DIN rails	
extending communication.....	39
positioning	14
power transfer.....	35

E

electrical specifications	
service boxes.....	43
TX-I/O product range.....	20
enclosures	
dimensions	44
placement.....	47–48

G

grounding	
Digital Input modules.....	29
general requirements	13
I/O modules	13
service box	13
Super Universal modules	34
Universal I/O modules	31

I

I/O modules	
diagram	25
Digital Input modules.....	29
Digital Output modules.....	30
feature summary	28
product numbers	24
specifications.....	20
Super Universal I/O modules	33
symbols and LEDs	25
troubleshooting.....	51
TX-I/O bus.....	19
Universal I/O modules	31
input support	32, 34
Insight software.....	21

L

label holder	24
label paper	24
LCD symbol chart	27
LED	
Bus Connection modules	38
I/O modules	25
P1 BIM.....	18, 50
Power Supply	37
local override/identification device (LOID) .	32, 34

M

MEC Expansion Bus.....	15
------------------------	----

N

network architecture	15
----------------------------	----

O

operating environment
 enclosures and service boxes42–43
 TX-I/O product range20

P

P1 BIM
 description 12
 diagram 18
 maximum points and modules 12
 power consumption 20
 power functions 35
 power output 12, 20
 product number 12
 specifications 20
 symbols and LEDs 18
 troubleshooting 50
 P1 FLN 15
 power specifications
 service boxes 43
 TX-I/O product range 20
 Power Supply
 description 36
 diagram 37
 functions 35
 installation requirements 13
 product numbers 36
 specifications 20
 symbols and LEDs 37

product numbers
 Bus Connection modules 38
 enclosures and service boxes 41
 P1 BIM 12
 Power Supply 36
 PX Series enclosures 40
 product numbers 41
 specifications 42

S

service box grounding 13
 service boxes 41
 Super Universal I/O modules 33
 supply terminal connections 31, 33
 symbols
 Bus Connection modules 38
 P1 BIM 18
 System Neutral 13, 39

T

TX-I/O Modules
 description 22
 product numbers 24
 TX-I/O Module Feature Summary 28
 TX-I/O Product Range Specifications 20

U

Universal I/O modules 31