



Step - By - Step AC Installation Guide



Index

AC Installation Guide - 1	
Welcome to the Step-By-Step AC Installation Guide	03
AC Installation Guide - 2	
Safety Guidelines When Installing Central Air	04
AC Installation Guide - 3	
What You'll Need	05
AC Installation Guide - 4	
Find a Spot for Your New AC Unit.....	06
AC Installation Guide - 5	
Cut a Hole in Wall of Home to Run Wires and Tubing.....	07
AC Installation Guide - 6	
Install Coil (Uncased).....	08
AC Installation Guide - 7	
Install Line Set.....	20
AC Installation Guide - 8	
Prepare High-Voltage Connections.....	27
AC Installation Guide - 9	
Hook Up Low Voltage Wiring (24 Volts).....	42
AC Installation Guide - 10	
Complete the Job.....	49

AC Installation Guide - 1

Welcome to the Step-By-Step AC Installation Guide

Welcome to Alpine Home Air Products Step-By-Step Central Air Conditioning Installation Guide. Installing your own air conditioning is easy. Follow along with this simple guide, complete with photographs and diagrams.

You can also view our 12 minute sample online installation video. This video is a sample of a full 1 hour AC installation DVD included with your purchase. Click [here](#) to view.

AC Installation Guide - 2

Safety Guidelines When Installing Central Air

- ▶ All products must be installed according to manufacturer's installation instructions and safety guidelines.
- ▶ All work must be done according to local and national building, electrical and mechanical codes.
- ▶ Wear proper safety equipment when performing your installation.
- ▶ Get local permits if necessary.
- ▶ Do not adjust or handle refrigerant unless you are EPA-Certified.
- ▶ Do not handle high-voltage electrical wiring unless properly trained.
- ▶ Be careful when handling sheet metal - it can be very sharp.
- ▶ Improper installation of products or improperly servicing a furnace can cause serious injury or death.
- ▶ This installation guide is not exhaustive of the subject matter, nor does it replace the manufacturer's instructions or requirements.
- ▶ If you do not fully understand how to install your product after reading the manufacturer's instructions, contact your local heating and air conditioning dealer for help and do not attempt to install it yourself.
- ▶ Alpine Home Air Products, its partners, the product manufacturers or any other providers of your purchased items cannot be held responsible for any damages, liability or litigation for any consequences, damages or injury that results from improper use or installation.

AC Installation Guide - 3

What You'll Need

Tools:

- L-Square
- Sheet Metal Shears
- Sheet Metal Benders (optional)
- Wire Cutters
- Wrench
- Screwdriver
- Tubing Cutter
- Hole Saws (around 2 inches)
- Tape Measure
- Drill
- Drill Bits

Supplies (Contained in the AHA AC Supplies Packages):

- Prefabricated Sheet Metal
- ½" Drain Tubing
- Low-Voltage, 4-Conductor Wire
- Plastic Tie Wraps
- Sheet Metal Screws
- Hex Nut Driver
- Low Voltage Wire Nuts
- Evaporator Drain Fitting
- Copper Fittings
- Spade Connectors
- Plastic Hangers for hanging pipe

Equipment:

- Condensing Unit or Heat Pump
- Line Set
- Electrical Whips
- Electrical Safety Shut-Off - Disconnect

AC Installation Guide - 4

Find a Spot for Your New AC Unit

1. Choose a spot for your condensing unit, outdoors. Some locations are better than others. Some things to keep in mind:
 - Ground needs to be level and secure.
 - Keep unit out of constant, direct sunlight, if possible. It will run more efficiently in the shade.
 - Unit should not be positioned directly under a gutter or where excessive water could pour down on it. Rain won't hurt the unit, but it's best to keep it from needlessly getting wet.
 - Unit should be close to electrical circuit panel in home for an easier wiring run.
 - Unit should not be placed too closely to plants. The unit needs clearance around it for adequate airflow.
 - For cosmetic reasons, the unit should be placed in an area that is slightly hidden from direct view of home.
 - Unit must be three feet away from a gas or electric meter. See local codes.
2. Make sure there is a ten-to-twelve-inch clearance between the condensing unit and the walls of your home.
3. Cut bushes back, if necessary.



4. Place the condensing pad in the spot chosen for the condensing unit. Make sure the spot is level. Level ground with a shovel if necessary.
5. Center the condensing unit on the condensing pad.



AC Installation Guide - 5

Cut a Hole in Wall of Home to Run Wires and Tubing

1. Cut hole in a spot near the condensing unit and near the bottom of your home. The hole should allow access to 1) run wires to the main electrical panel; 2) run pipes to furnace or air handler.
2. Find something visible both inside and outside of the home as a point of reference (like a water spigot or electrical hole for phone wires) to ensure you do not drill the hole in the wrong area.
3. From the outside of the home, use the hole saw to drill hole at marked spot.

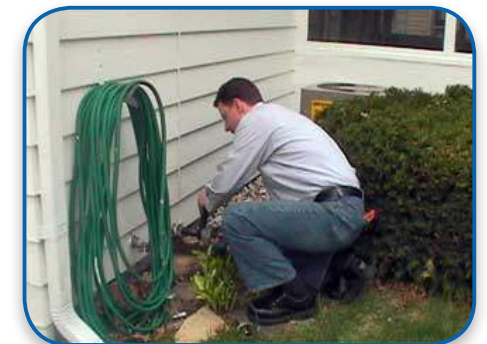

AC Installation Guide - 6

Install Coil (Uncased)

Note: Skip the following steps if 1) you have an air handler, since the coil is already installed inside it, or 2) you have a cased coil, since it will fit on the top of your furnace (or on the side if it is a horizontal coil).

Cut Opening on Supply Plenum to Mount Coil Within It

Objective: Cut opening in side of supply plenum (located on top of your furnace) to mount evaporator coil inside

1. Measure the width of the evaporator coil at its widest point.
2. Add one half inch to the width. This will be the measurement for the width of the rectangle you cut out of the supply plenum.



3. Measure the height of the evaporator coil at its highest point.
4. Add one half inch to the height. This will be the measurement for the length of the rectangle you cut out of the supply plenum.



5. Using a marker and your L-Square mark the correct dimensions (the width from Step 2 and the height from Step 4) on the side of the supply plenum.



6. Use your drill to cut a hole out in the corner of the rectangular outline you drew. (This will allow you to use your sheet metal shears to start cutting out the rectangle.)



7. Using your sheet metal shears, cut along the rectangular outline you drew on the supply plenum. Be careful, because sheet metal is extremely sharp.



8. Remove and carefully discard the rectangle you cut out of the supply plenum.



Build Sheet Metal Shelves to Hold Evaporator Coil Inside Plenum

Objective: Build sheet metal shelves inside supply plenum so that evaporator coil can sit centered inside plenum. Four sheet metal shelves are supplied with your supplies package. Each is larger than what you will need and are designed to be cut to size to fit your exact application.

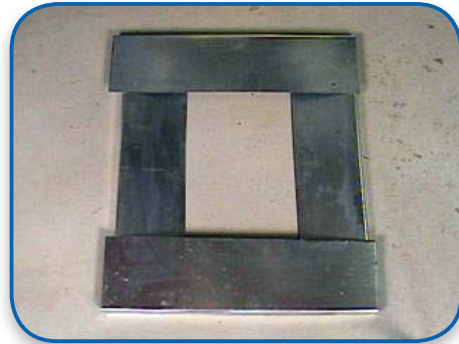

Objective: Trim the shelves so that they fit inside the plenum, but do not block airflow into bottom of coil. This is what the coil will look like sitting on top of the sheet metal shelves. This will all be mounted inside the supply plenum.

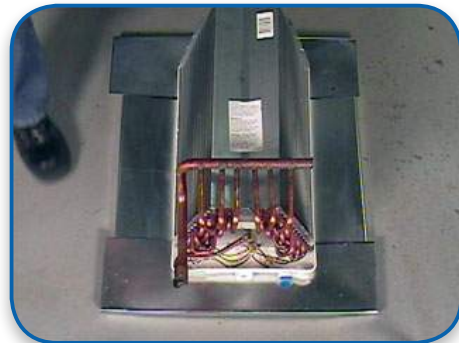

Objective: The shelves should be cut narrowly enough that the full coil opening is exposed to the air stream beneath it, but not so narrowly that the coil does not have enough of a base to sit on. This photograph shows the bottom of the coil and how far over the sheet metal should reach.



Objective: To ensure that water runs forward to the drain hole in the plastic tray on the bottom of the coil, the back shelf should be positioned 1/2" higher than the front shelf. This will create a 1/2" forward pitch on the coil and will allow water (which collects as water condenses on the cold evaporator coil) to drain out of the plastic tray.



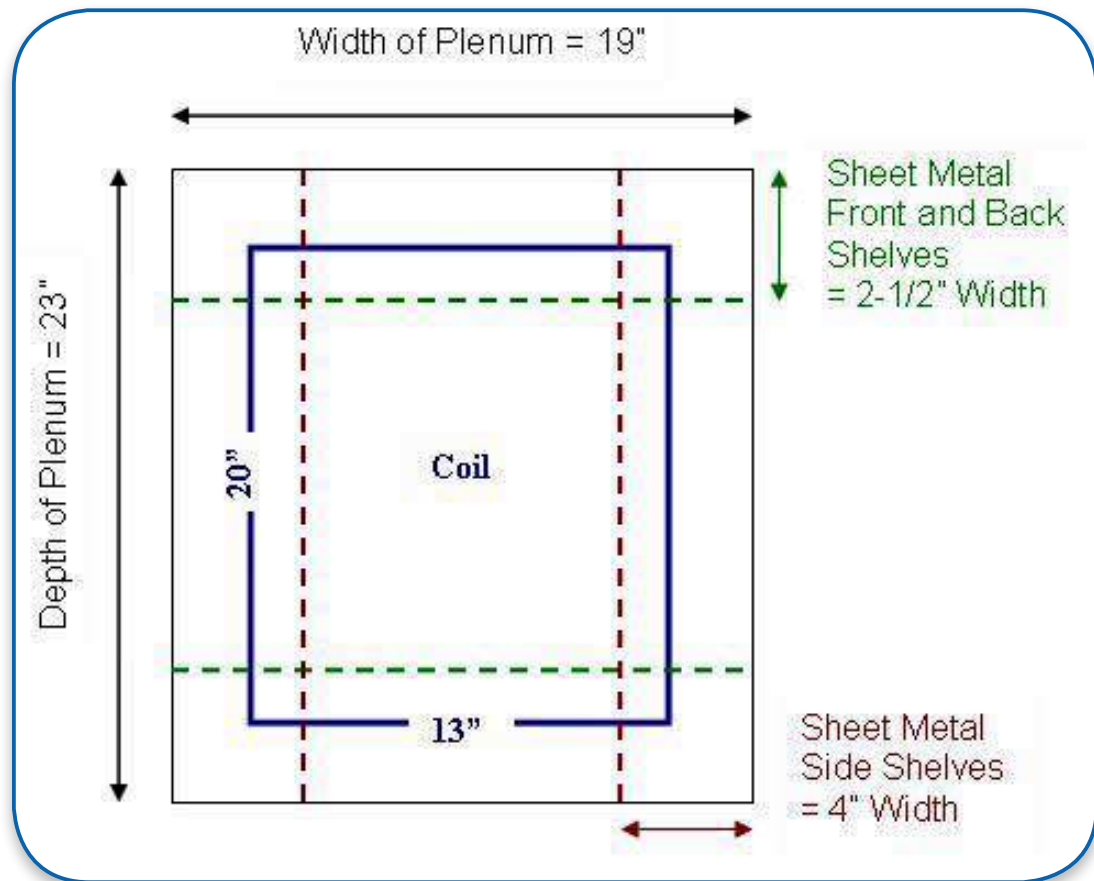

The dimensions in the diagram are for example purposes ONLY. **Your measurements will be different.**

1. Cut sheet metal shelves the appropriate width.
2. Width of Front and Back Shelves = $(\text{Depth of Plenum} - \text{Length of Coil})/2 + 1$ ($23'' - 20''$)/2 + 1 = 2.5''
3. Width of Side Shelves = $(\text{Width of Plenum} - \text{Width of Coil})/2 + 1$ ($19'' - 13''$)/2 + 1 = 4''
4. Cut the shelves on the sides opposite the 90-degree bend.

5. Cut the front and back sheet metal shelves to same length as the width of the plenum. Set the front shelf aside.
6. Position the back shelf so that the flap points downwards and against the plenum wall. Place it 1/2'' higher than where you will locate the front shelf.
7. Drill screws into the sheet metal flap to secure the shelf to the plenum wall.



8. Cut the side shelves the same length as the depth of the plenum.
9. Position the shelves so that the flaps of the sheet metal point downward against the plenum wall on both sides.
10. Drill screws into the flaps to secure both sheet metal shelves.



11. Position the front shelf 1/2'' lower than the back shelf with the flap pointing downward against the plenum wall.



12. Drill enough screws into corners of shelves to secure all four.



13. Slide coil into plenum on top of shelves, with refrigerant lines pointing outward



14. Place sheet metal cover (found in supplies package) over plenum opening, fitting the refrigerant lines and the drain connectors through the designated holes.

15. If the sheet metal cover fits flush over the plenum opening, use your marker to mark the back of the cover where it meets the edges of the plenum. Go to Step 16. If the coil protrudes from the opening and the cover is not flush with the plenum, skip Step 16 and see instructions to “Create a Raised Sheet Metal Cover” below.

16. Screw the sheet metal cover into place, making sure not to put any screws through the white plastic condensate tray on bottom of coil. You are ready to install your line set. Skip the following steps.



Create a Raised Sheet Metal Cover

If the coil sticks out beyond the plenum opening (excluding the refrigerant lines) you will need to build a raised sheet metal cover.

1. To do this, first measure the number of inches the coil sticks out beyond the plenum opening.



2. Measure from the center of the suction line (this is the refrigerant line near top of coil that sticks out the furthest) to the plenum opening, on all four sides. Write these measurements down.

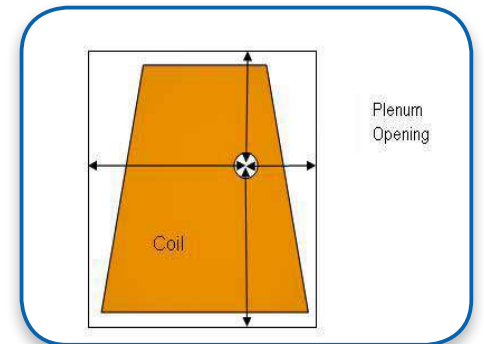

The dimensions on the sheet metal cover in the picture are for example purposes ONLY. Your measurements will be different.

3. Using your L-Square and marker, mark the measurements taken in step 2 on the sheet metal cover. Make sure all measurements start at the center of the top (suction line) hole. (Note: You can make the markings on the back side of the cover for cosmetic purposes, as well. Just make sure to flip the horizontal measurements.)
4. Draw a box properly distanced from the suction line hole on all sides, using the L-Square.
5. Measure the width and height of the box you drew.

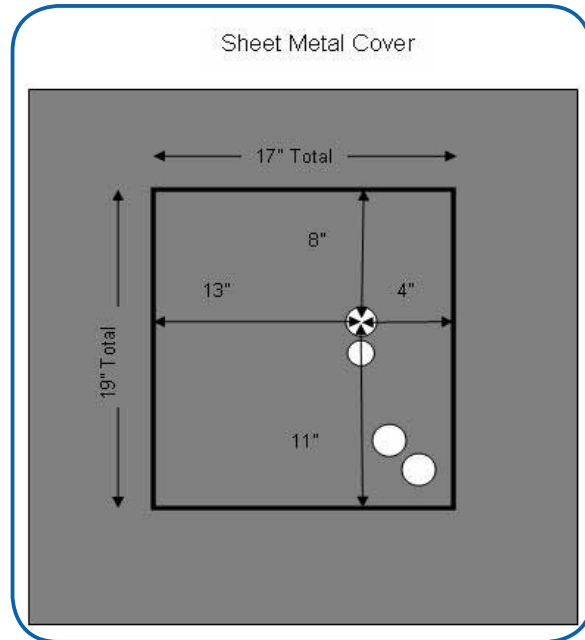

The dimensions on the sheet metal cover in the picture are for example purposes ONLY. Your measurements will be different.

6. Draw another rectangle around the first adding the number of inches that the coil sticks out beyond the plenum opening (determined in Step 1). For example, if the coil sticks out one inch beyond the plenum opening, add one inch to the width of the first rectangle (in this example $17'' + 1'' = 18''$) and add one inch to the length (in this example $19'' + 1'' = 20''$).

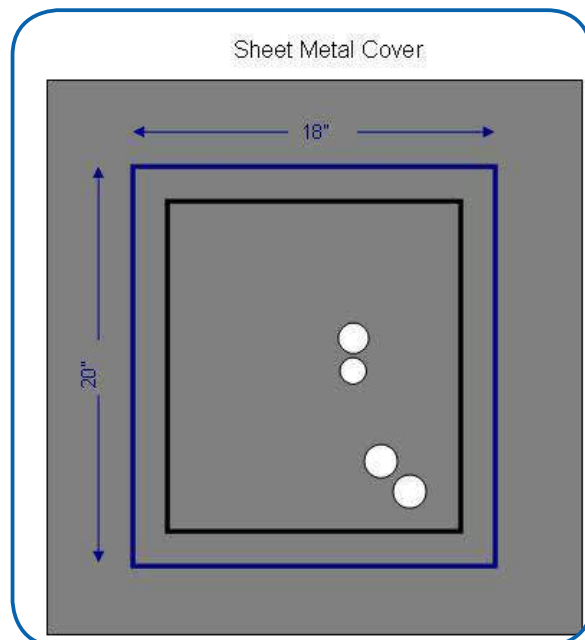

The dimensions on the sheet metal cover in the picture are for example purposes ONLY. Your measurements will be different.

7. Draw a third rectangle around the first two, $1/2''$ larger on all sides.

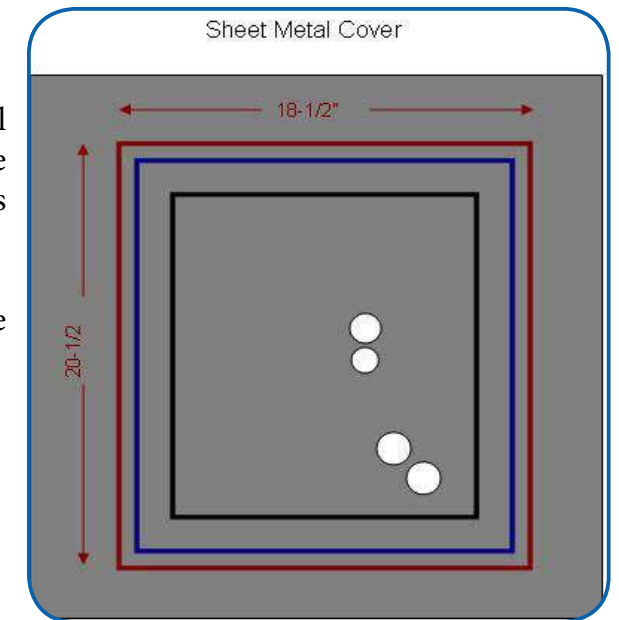

8. Cut around the edges of the outer rectangle with sheet metal shears.

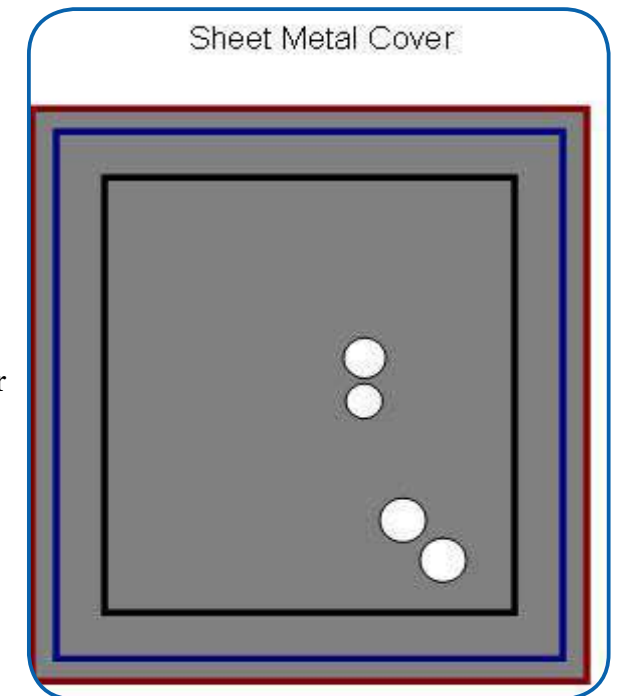

9. Cut out four corners on the sheet metal, the same dimensions as the number of inches the coil sticks out beyond the plenum plus a 1/2". Or simply cut squares out using the L-Square and inner-most rectangle as a corner.

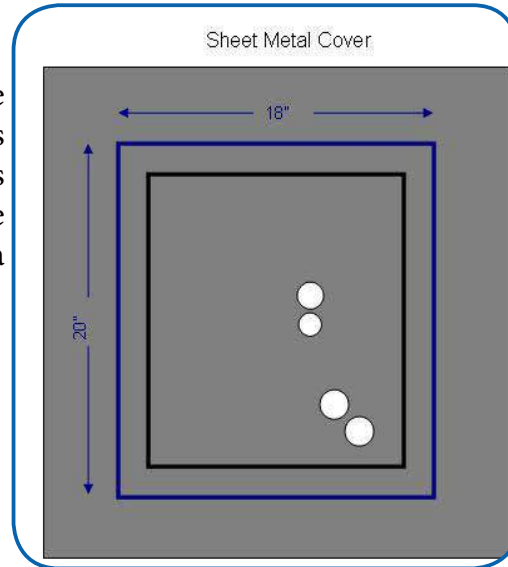

10. To create a 1/2" lip on the sheet metal, lay the cover on a flat surface front side up.
11. Place the L-Square on the edge of the middle rectangle.
12. Bend the sheet metal upwards, so that the outer edge of the cover forms a 90-degree angle with the middle rectangle.
(You can also use sheet metal benders, if you have them.)

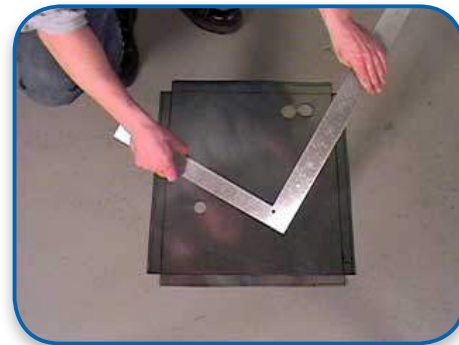

13. Flip the cover over.
14. Place the L-Square on the edge of the first rectangle you drew.
15. Bend the sheet metal upwards at the edge to form a 90-degree angle.



16. Place the raised cover over the plenum opening, allowing the drain connectors and refrigerant lines to fit through designated holes.



17. Drill screws into cover's 1/2" lip on all sides to secure it to the plenum. (Note: Make sure not to put any screws into white plastic condensate tray on bottom of coil as this may cause it to leak).



AC Installation Guide - 7

Install Line Set

Objective: The line set consists of two refrigerant lines that connect the condensing unit to the evaporator coil. To complete this part of the installation, connect the line set to the condensing unit and run it inside along the ceiling toward the evaporator coil. Your EPA-certified contractor will complete the installation.

1. Roll out suction line (the larger, insulated line) holding one end down with your foot.



2. Peel back a few feet of insulation on one end of line and cut off with knife. (The amount you peel back should be about the same length as the distance between the hole in your house and the condensing unit.) Set insulation aside.



3. Push enough of the suction line through the hole in the house to reach the condensing unit. If you push too much through, you can cut the line later.



4. Run suction line along the ceiling towards the evaporator coil.



5. Secure suction line to ceiling using line set mounting brackets. Use two screws on each side of bracket to hold in place. Use as many brackets as needed to firmly secure suction line.



6. Outside, the suction line may need to be redirected towards the condensing unit. To redirect the line, it must be cut and then fitted back together with 45-degree and/or 90-degree copper fittings (whichever best fits your application - you may need to use both). The suction line is slightly malleable, but sharply bending the line to redirect may cause it to kink.



7. Using a tube cutter, cut the suction line near the hole in your house. Make sure that the length of the suction line you cut off is long enough to reach the condensing unit.



Continued from Step 8.



Continued from Step 7.



9. Reattach the piece of piping cut off from the end.



8. Attach either a 90-degree or 45-degree copper fitting to the end of the suction line where it protrudes from hole in house. (Use whichever fitting is necessary to redirect the line appropriately.)



10. As in this example, both a 90-degree and 45-degree copper fitting are used to redirect the suction line to the condensing unit. You may need to cut the pipe twice and use two fittings.



11. Redirect the pipe to the condensing unit.



12. Press the suction line into the suction line surface valve on the condensing unit.

Tip: Keep suction and liquid lines clean inside. These are sensitive environments when the air conditioning runs. Cleanliness and dryness are important for proper air conditioning operation.

Tip: When bending copper, be careful not to crimp or kink it. If you do accidentally crimp or kink it, the pipe is not unsalvageable. Straighten out the piping, splice it with the tube cutter and rejoin the cut ends with a copper coupling.

13. Back inside home, run the smaller liquid line (smaller of the two lines in line set) out through hole in house. Push enough of the line through to reach the condensing unit.



14. Run the liquid line along the suction line and through the same line set mounting brackets already secured in place.



15. Outside, use slight pressure to bend the liquid line and run it towards the condensing unit. Copper fittings are not necessary to bend the liquid line.



16. Attach the liquid line to the liquid line surface valve on the condensing unit by pressing it into place.



17. Back inside, trim liquid line with a tube cutter several inches longer than necessary to reach the evaporator coil.



18. Using a knife, cut the insulation off the end of the suction line.



19. Trim suction line with tube cutter several inches longer than needed to attach to evaporator coil.



20. Leave refrigerant lines hanging for contractor to solder connections



AC Installation Guide - 8

Prepare High-Voltage Connections

A central air conditioner runs on 220 volts of electricity. A connection must be made between the main electrical circuit panel in your home and the condensing unit in order for the air conditioning to run. You can prepare the wiring for hook-up, but only a skilled contractor should complete the high-voltage wiring. Inexperience can cause electrical shock or damage to your equipment or property.

You will need to select the correct thickness of wire and corresponding breaker based on your condensing unit. Wires are rated by gauge. The higher the gauge number, the thinner the wire. Most residential AC units use 8 or 10-gauge wire. See the manufacturer's spec sheets for more information.

The first step to preparing your high-voltage connections is to install the disconnect. Electrical codes require a disconnect/safety switch to be located near the condensing unit. Check your local electrical codes for specifics.

The disconnect will have two electrical whips running in and out of it: one runs from the condensing unit to the disconnect and the other runs from the home's electrical circuit panel to the disconnect.

Install Disconnect Box and Electrical Whips

1. Select a spot on wall to mount disconnect box.
 - Locate it near the hole in the house and close to condensing unit.
 - Place it high enough up to keep it out of snow or water on ground.
 - See electrical codes for specifics on where to locate the disconnect.
2. Pull cover off of disconnect box to see inside. You will find spots to attach wires and small holes to mount the box with screws.
3. Remove the On-Off switch.
4. Punch out one pre-stamped hole on each side (or bottom) of disconnect box. Punch out the holes that are properly-sized for the electrical whips. One electrical whip will be inserted on each side.

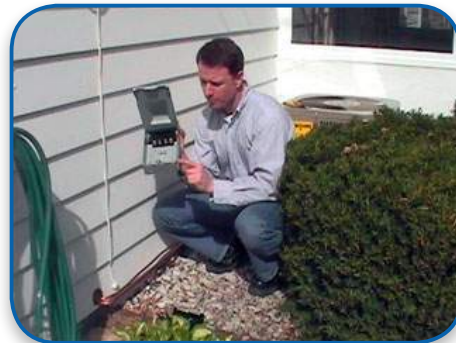
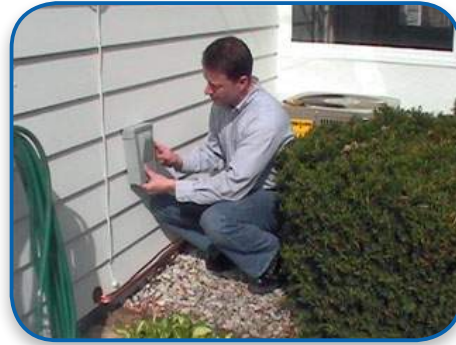

5. Mount the box to the wall with screws and drill.



6. Slide whips through holes in box and tighten nuts. (See Step 6 for more details.)



7. One whip has a 90-degree bend and one has a straight end. Use the whip on each side that best fits your application.



Hook wires up inside the disconnect box. The green wires are the ground wires.

8. Cut the two green wires to size and strip back 1/2" of insulation.
9. Hook up both wires, each one under either lug in center of disconnect and tighten down with screwdriver. Make a good solid connection.



For the whip closest to condensing unit, hook up the red and black wires inside box at the "load" terminals (in center, near top of disconnect).

10. Cut the red and black wires to size and strip off 1/2" of insulation.
11. Hook up each wire under either lug.



12. Tighten lugs down with screwdriver. High voltage needs a good, solid connection.



13. On the other whip, cut the red and black wires to size and strip back 1/2" of insulation.

14. Hook up the red wire to the terminal closest to the red wire just installed. Tighten down with screwdriver.

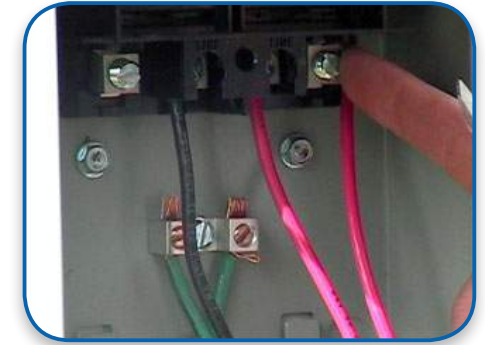

15. Hook up the remaining black wire to the terminal closest to the black wire just installed. Tighten down with screwdriver.



16. Slide the electrical whip closest to hole in house, through the hole.

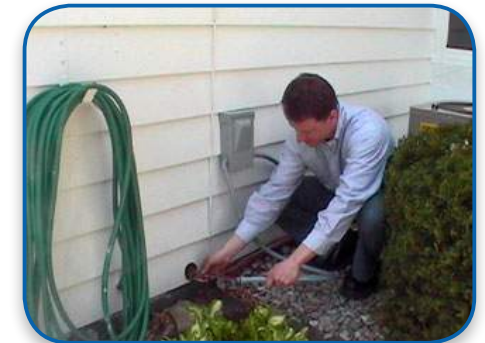

- 17. Replace On/Off Switch in disconnect box.
- 18. Turn switch to Off until contractor starts unit.



Mount Whip To Ceiling, Connect Flexible Wire and Run to Home's Electrical Panel

Back inside home, the whip needs to be mounted to the ceiling, wires connected to it and the wires run to home's electrical circuit panel.

- 19. Find a spot on the ceiling to mount the whip and wires. See local electrical and building codes for more allowable placement



- 20. Use a standard 4x4 junction box (available at any hardware store) to mount whip and wires. Screw box into place.



- 21. Punch out appropriately-sized holes on both sides of junction box.



- 22. Run whip into junction box on side closest to hole in house.



- 23. Run flexible wire from junction box to home's electrical panel. Use the correct wire gauge (based on your condensing unit). Flexible wire such as Romex may be used if building/electrical codes permit. Some building/electrical codes require the use of solid, conduit pipe to pass wires through.



24. Strip about one foot of insulation from wire.



25. Slide wires into box connector (available at any hardware store).



26. Slide box connector down the wires to where the insulation begins.



27. Tighten down top screw on box connector until it holds insulated wire securely.

- Don't pinch the wires by tightening the screws down too tightly.
- The connector itself is not screwed into anything, yet.



28. Tighten down bottom screw on box connector.



29. Remove nut on end of box connector.



30. Slide wires through hole in side of junction box.



31. Replace nut.



32. Hand-tighten nut to secure wires.



33. Match wires by color inside junction box. Attach wires from whips to corresponding Romex wires.

- Green (ground) matches copper.
- Red matches red or white.
- Black matches black.

34. Trim wires and cut back 1/2" of insulation. Use wire nuts to make connections.



35. Replace cover on junction box once you have matched all wires.



36. Secure flexible wire to ceiling with nails, wire staples and hammer.



37. Run flexible wire over to main electrical circuit panel in home.



38. Spool wire up for contractor to complete high voltage wiring on panel.



Hook Up High Voltage Wiring to Condensing Unit

39. Outside, remove screws from access panel on front of condensing unit.



40. Remove access panel.



41. Remove nut from electrical whip hanging from disconnect box.

42. Run whip up through the high-voltage electrical hole that protrudes from corner of condensing unit.



43. Slide nut over wires.



44. Tighten nut down on washers.



Use spade connectors to make an easy connection.



45. Trim ground (green) wire and strip back 1/2".

46. Place ground wire under lug located on side.

47. Tighten down with screwdriver.

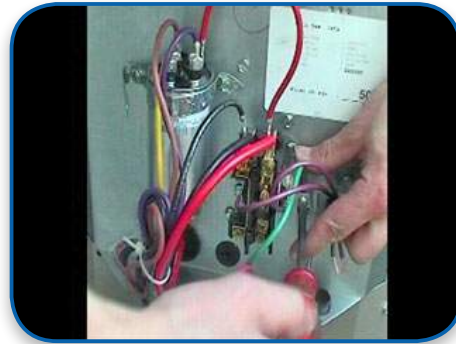

48. Slip spade connectors over end of red and black wires.



The remaining black and red wire from whip will be connected to either side of contactor.



49. Crimp end of spade connectors with spade crimpers or pliers.

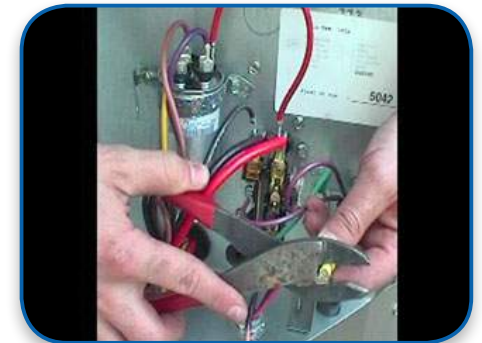

50. Press red and black wires with spade connectors up into contactors, one on each side.



3. Run wires up through low-voltage electrical hole in front of condensing unit.



AC Installation Guide - 9

Hook Up Low Voltage Wiring (24 Volts)

Hook up Low Voltage Wires to Condensing Unit

Hook up Two-Conductor, 18-Gauge wire (found in Supplies Package) to condensing unit.

1. Run wires out hole in side of house.



2. Outside, pull wires through hole and run towards condensing unit.



4. Strip 1/2" of insulation from end of both wires.



5. Use two blue wire nuts to connect the two incoming 24-volt wires with the 24-volt wires already attached to the condensing unit.



6. Make sure all four wires are stripped 1/2”.



(After your contractor solders your line set connections, replace the foam insulation that you had previously removed from suction line. Use tie wraps to secure it.)



7. Secure wire nuts by squeezing on ends of wires.



(Run 24-Volt wire along same line and secure with additional tie wraps. Wait to do this until you can replace the insulation.)



8. Replace access panel on condensing unit.



Run Low Voltage Wiring Along Ceiling to Furnace or Air Handler

1. Inside, run the 24-Volt wire alongside the line set and secure with plastic tie wraps.



2. Make sure that the power to the furnace/air handler is turned OFF.



3. Remove the access panel on the front of the furnace/air handler.



For a standard gas furnace, the control wiring area displays five or six terminals. Terminals are labeled C, Y, Gc, Gh, R and W or C, Y, G, R and W. Notice that two wires from your thermostat are already hooked up to the R and W terminals.



4. Trim the two 24-Volt wires so that they are long enough to reach the terminals.
5. Strip both wires back 1/2”.
6. Hook up either of the two wires to terminal C and tighten down with a screwdriver.
7. Hook up the other wire to terminal Y and tighten down with a screwdriver.

(Some furnaces require you to make connections with wire nuts. In this case, you will connect the 24-Volt wires to the blue furnace wire and the yellow thermostat wire using wire nuts. For more information on wiring for these, see [our wiring diagrams](#).)

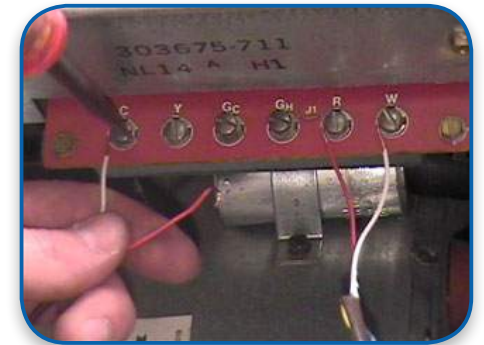

Next, you will hook up the thermostat to the condensing unit so that it can turn the air conditioning on and off.

You need a total of four wires to run from the thermostat to the furnace/air handler to make the air conditioning run. The wire hooked to the R and W terminals should be four-conductor wire (meaning that two extra wires will be available to hook to two more terminals for air conditioning). The two extra wires should be protruding from the wire casing. If there are not two extra wires, you only have two-conductor wire and it must be replaced with four-conductor wire.

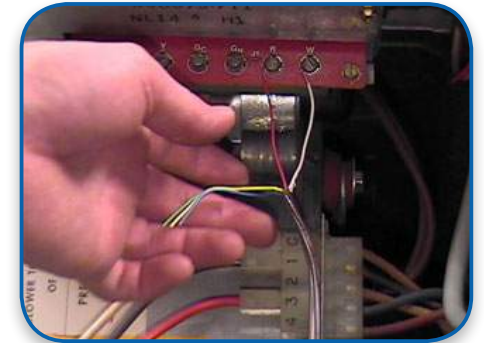

- Hook the extra green wire to the G or Gc terminal and the extra yellow wire to the Y terminal.

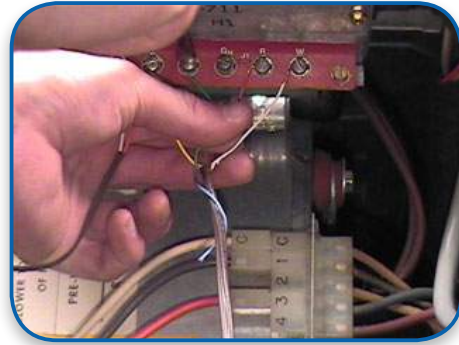

- Replace access panel on furnace or air handler.



Run Wires from Furnace/ Air Handler and Hook up to Thermostat

- Remove the cover from your thermostat. Make sure your thermostat has both heating and cooling capability. Install a new thermostat if necessary.



- Inside the thermostat, hook up the white wire to terminal W, the green wire to terminal G, the yellow wire to terminal Y, and the red wire to terminal R (if there are two R terminals, be sure to install a jumper).

If this is not the lettering configuration in your thermostat, simply leave the wires hanging for final installation by your contractor.



- Replace your thermostat cover.



AC Installation Guide - 10 Complete the Job

Install Drain Tubing

- Use the white barb drain connector to hook up your drain tubing to the evaporator coil. This will allow water that condenses on the coil to empty into a floor drain.



If you do not have a floor drain, a [Condensate Drain Pump](#) can be used. When installed, this device allows water to be pumped up or down into an area that allows drainage.

2. Screw the connector into the drain hole already cut on your sheet metal cover.



3. Fit the 1/2" drain tubing up into the connector. Make sure the tubing fits snugly.



Hire a Contractor

Installing central air conditioning consists of two primary parts: what you can do on your own (about 90 percent of the job) and what you need to hire a contractor to complete. Due to federal laws pertaining to the handling of refrigerant, as well as special tools required, the completion of the job needs to be handled by an air conditioning professional. Federal law requires that the individual be EPA-certified to handle refrigerant. The completion of the project usually costs about \$100 - \$300, depending on local labor costs and the extent of the work to be completed.

The contractor will solder your copper refrigerant line connections.



The contractor will pull a vacuum on the refrigerant line with a vacuum pump.



The contractor will release refrigerant from condenser into system, start system up and balance pressures.



The contractor will connect high voltage wiring to home's main electrical circuit panel.



2. Use tie wraps to secure low-voltage wiring to line set.

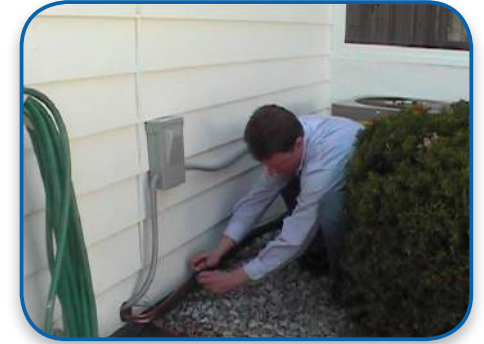

The contractor will inspect your entire installation.



3. Use caulking or thumb gum to seal hole in side of house



Final Details

1. Replace insulation on outside portion of copper line set.





Step - By - Step AC Installation Guide