

INSTALLATION INSTRUCTIONS

Table of Contents

Dimensions in. (mm).....	2
Parts Arrangement.....	2
Shipping and Packing List.....	3
General.....	3
Requirements.....	3
Unit Support.....	4
Duct Connection.....	4
Rigging Unit For Lifting.....	5
Unpacking.....	5
Downflow Air Discharge.....	5
Horizontal Air Discharge.....	6
Condensate Drains.....	6
Connect Gas Piping.....	7
Pressure Test Gas Piping.....	7
Install Vent Hood.....	8
High Altitude Derate.....	8
Electrical Connections.....	8
Blower Operation and Adjustments.....	9
Cooling Start-Up.....	13
Gas Heat Start-Up.....	14
Heating Operation and Adjustments.....	16
Service.....	17
Start-Up Report.....	21

QGA036 ULNOx	3-Ton
QGA042 ULNOx	3-1/2-Ton
QGA048 ULNOx	4-Ton
QGA060 ULNOx	5-Ton

GAS AND COOLING PACKAGED UNITS
 508161-01
 07/2021

⚠ WARNING

Improper installation, adjustment, alteration, service or maintenance can cause property damage, personal injury or loss of life. Installation and service must be performed by a licensed professional HVAC installer or equivalent, service agency, or the gas supplier.

⚠ CAUTION

As with any mechanical equipment, contact with sharp sheet metal edges can result in personal injury. Take care while handling this equipment and wear gloves and protective clothing.

RETAIN THESE INSTRUCTIONS FOR FUTURE REFERENCE



Dimensions in. (mm)

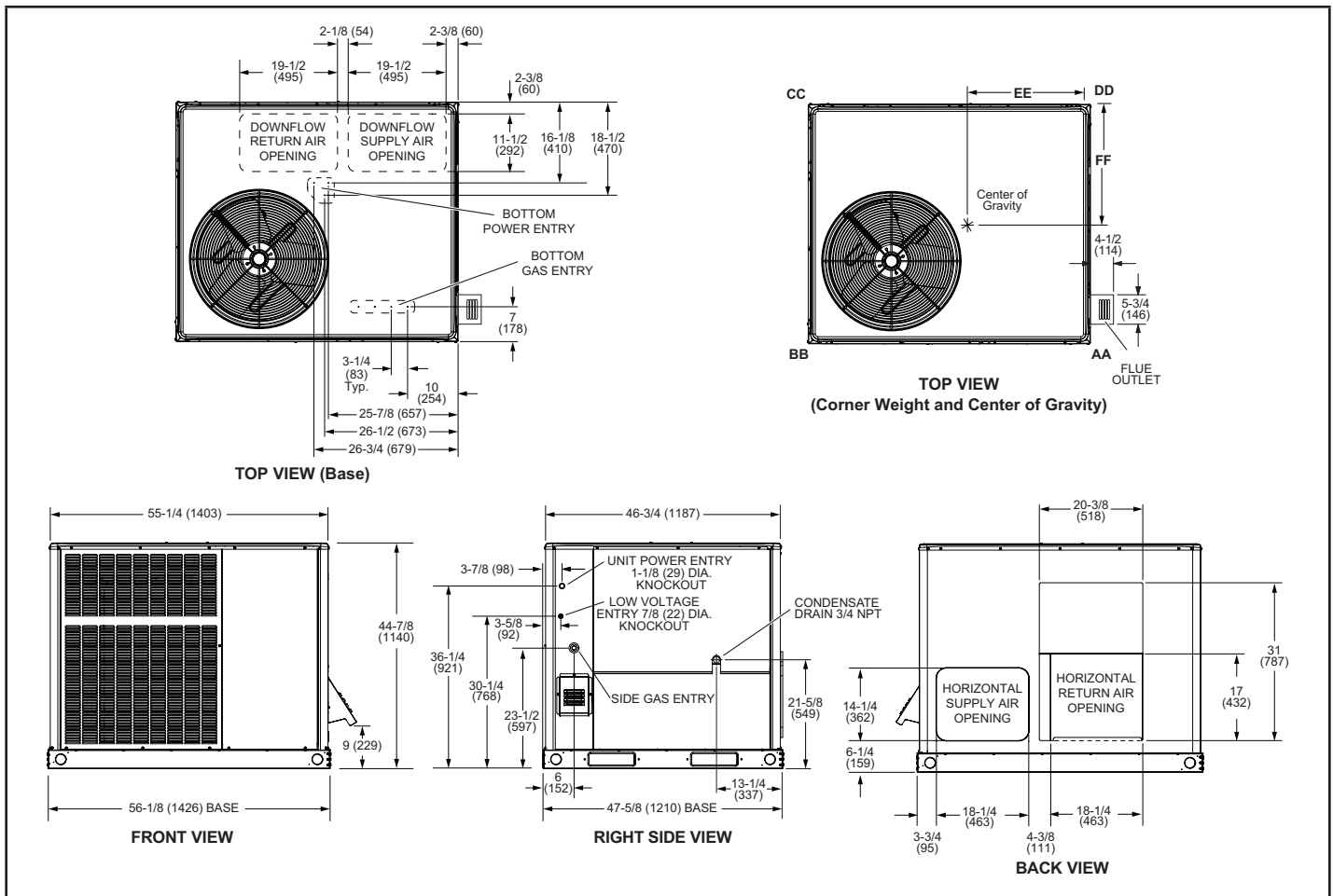

Parts Arrangement

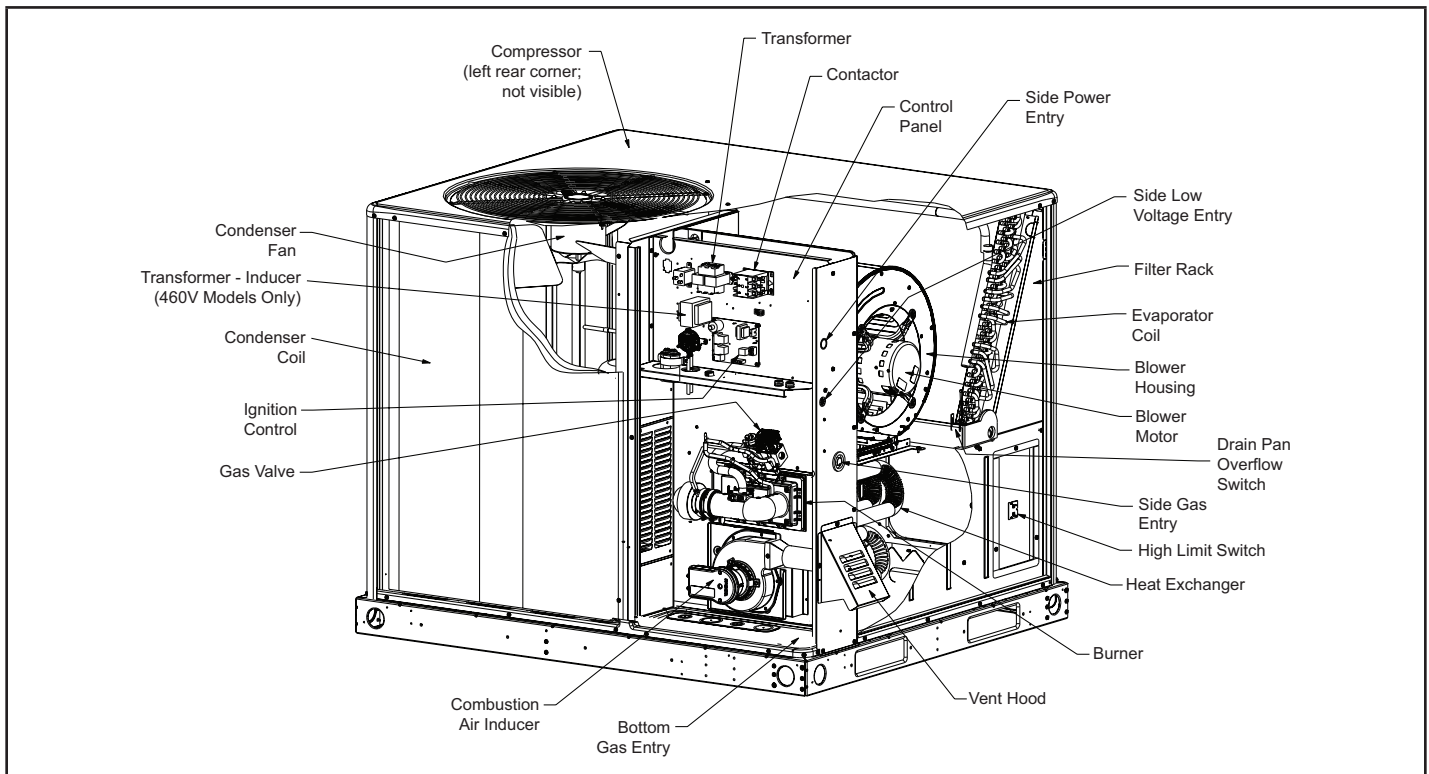

Shipping and Packing List

Package 1 of 1 contains:

1 - Assembled unit

Check unit for shipping damage. Receiving party should contact last carrier immediately if shipping damage is found.

General

These instructions are intended as a general guide and do not supersede local codes in any way. Authorities having jurisdiction should be consulted before installation.

The QGA ULNOx units are gas/electric packaged units available in four cooling capacities and two gas heating inputs.

Requirements

See FIGURE 1 for unit clearances.

⚠ NOTICE

Roof Damage!

This system contains both refrigerant and oil. Some rubber roofing material may absorb oil, causing the rubber to swell. Bubbles in the rubber roofing material can cause leaks. Protect the roof surface to avoid exposure to refrigerant and oil during service and installation. Failure to follow this notice could result in damage to roof surface.

⚠ WARNING



Electric shock hazard and danger of explosion. Can cause injury, death or product or property damage. Turn off gas and electrical power to unit before performing any maintenance or servicing operations on the unit. Follow lighting instructions attached to unit when putting unit back into operation and after service or maintenance.



⚠ IMPORTANT

The Clean Air Act of 1990 bans the intentional venting of refrigerant (CFC's and HCFC's) as of July 1, 1992. Approved methods of recovery, recycling or reclaiming must be followed. Fines and/or incarceration may be levied for non-compliance.

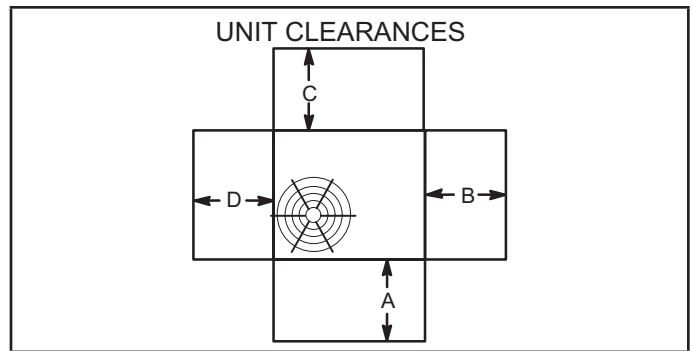

FIGURE 1

¹ Unit Clearance	A in.	B in.	C in.	D in.	Top Clearance
Service Clearance	24	24	0	24	48
Clearance to Combustibles	0	12	0	0	0

¹Clearance to combustibles below the unit flue is 10 inches since the flue points down.

NOTE - Entire perimeter of unit base requires support when elevated above mounting surface.

¹ Service Clearance - Required for removal of serviceable parts.

Clearance to Combustibles - Required clearance to combustible material (gas units).

Minimum Operation Clearance - Required clearance for proper unit operation. Location

- 1 - Unit is designed for outdoor installation only. Unit must be installed so all electrical components are protected from water.
- 2 - Condenser coils must have an unlimited supply of air.
- 3 - For ground level installation, use a level prefabricated pad or use a level concrete slab. Do not tie the slab to the building foundation.
- 4 - Maintain level within a tolerance of 1/4" maximum across the entire length or width of the unit.

⚠ CAUTION

Unit levelness is critical for proper float switch operation.

Use of this unit as a construction heater or air conditioner is not recommended during any phase of construction. Very low return air temperatures, harmful vapors and operation of the unit with clogged or misplaced filters will damage the unit.

If this unit has been used for heating or cooling of buildings or structures under construction, the following conditions must be met or the warranty will be void:

- A room thermostat must control the unit. The use of fixed jumpers that will provide continuous heating or cooling is not allowed.
- A pre-filter must be installed at the entry to the return air duct.
- The return air duct must be provided and sealed to the unit.

- Return air temperature range between 55°F (13°C) and 80°F (27°C) must be maintained.
- Air filters must be replaced and pre-filters must be removed upon construction completion.
- The input rate and temperature rise must be set per the unit rating plate.
- The heat exchanger, components, duct system, air filters and evaporator coil must be thoroughly cleaned following final construction clean-up.
- The unit operating conditions (including airflow, cooling operation, ignition, input rate, temperature rise and venting) must be verified according to these installation instructions.

Unit Support

In the U.S., units may be installed on combustible floors made from wood or class A, B, or C roof covering material.

In Canada, units may be installed on combustible floors.

NOTE - Securely fasten roof curb to roof per local codes.

CAUTION

To reduce the likelihood of supply / return air bypass and promote a proper seal with the rooftop unit, duct work / duct drops / diffuser assemblies must be supported independently to the building structure.

A - Downflow Discharge Application

Roof Mounting with ACURB85

- 1 - The ACURB85 roof mounting curb must be installed, flashed and sealed in accordance with the instructions provided with the curb.
- 2 - The ACURB85 roof mounting curb should be square and level to 1/16" per linear foot (5mm per linear meter) in any direction.
- 3 - Duct must be attached to the roof mounting curb and not to the unit; supply and return plenums must be installed before setting the unit.
- 4 - Prior to setting the unit on the roof curb, remove the shipping bracket located underneath the unit. Remove the two screws in the base rail (located on the front and rear of the unit). The four screws and the bracket can be discarded. See FIGURE 2.
- 5 - Be sure that all required clearances are observed (see Clearances section).

Installer's Roof Mounting Curb

Many types of roof curbs can be used to install the unit depending upon different roof structures. Items to keep in mind when using the building curb or supports are:

- 1 - The base is fully enclosed and not insulated, so an enclosed, insulated curb is required.
- 2 - The curbs or supports must be constructed with non-combustible materials and should be square and level to 1/16" per linear foot (5mm per linear meter) in any direction.
- 3 - Curb or supports must be high enough to prevent any form of moisture from entering unit. Recommended minimum curb height is 14" (356mm).
- 4 - Duct must be attached to the roof mounting curb and not to the unit. Supply and return plenums must be installed before setting the unit.
- 5 - Units require support along all four sides of unit base. Supports must be constructed of steel or suitably treated wood materials.

B - Horizontal Discharge Applications

- 1 - Specified installation clearances must be maintained when installing units. Refer to FIGURE 1.
- 2 - Top of support slab should be approximately 4" (102mm) above the finished grade and located so no run-off water from higher ground can collect around the unit.
- 3 - Units require support along all four sides of unit base. Supports must be constructed of steel or suitably treated wood materials.

Duct Connection

All exterior ducts, joints and openings in roof or building walls must be insulated and weather-proofed with flashing and sealing compounds in accordance with applicable codes. Any duct passing through an unconditioned space must be insulated.

The duct system should be designed and sized according to the methods in the Air Conditioning Contractors of America (ACCA) manual that is most appropriate to the installation application.

A closed return air duct system shall be used. This shall not preclude use of economizers or outdoor fresh air intake.

It is recommended that supply and return air duct connections at the unit be made with flexible joints. The supply and return air duct systems should be designed for the CFM and static requirements of the job. They should not be sized by matching the dimensions of the duct connections on the unit. The unit is shipped capable of either horizontal flow (side duct connections) or down flow (bottom duct connections). Duct attachment screws are intended to go into the duct panel. Duct to unit connections must be sealed and weather-proofed.

CAUTION

In downflow applications, do not drill or punch holes in base of unit. Leaking in roof may occur if unit base is punctured.

Rigging Unit For Lifting

Rig unit for lifting by attaching four cables to holes in unit base rail. See FIGURE 2.

Exercise care when moving the unit. Do not remove any packaging until the unit is near the place of installation.

- 1 - Connect rigging to the unit base rails using both holes in each corner.
- 2 - All panels must be in place for rigging.
- 3 - Place field-provided spreaders in place. Spreaders must be of adequate strength and length (must exceed unit dimension by 6 inches). Units may also be moved or lifted with a forklift. **The lengths of the forks of the forklift must be a minimum of 42 inches.**

CAUTION - Before lifting a unit, make sure that the weight is distributed equally on the cables so that it will lift evenly.

Unpacking

Locate the four stacking brackets at each corner of the top panel. Remove the screws that secure these brackets. All screws must be re-installed. The stacking brackets can be discarded. Remove the bag and remaining packaging material, which can be discarded. Locate the four plastic fork slot bumpers on the base rails. Remove the fasteners and bumpers and discard.

Downflow Air Discharge

Unit is shipped with panels covering the horizontal and downflow supply and return air openings (four covers).

- 1 - Before setting the unit on a roof curb, see “Roof Mounting” section for instructions on removing the shipping bracket underneath the unit.
- 2 - Remove and retain the horizontal supply and return duct covers.
- 3 - Remove the four screws securing the downflow duct covers inside the unit. Remove and discard the covers.
- 4 - Remove screws located between the supply and return air openings that attach the blower deck to the base, and discard these screws. These screws can interfere with bottom duct connections or roof curb seals.
- 5 - Install the duct system onto the unit.
- 6 - Replace the retained horizontal supply and return duct covers.

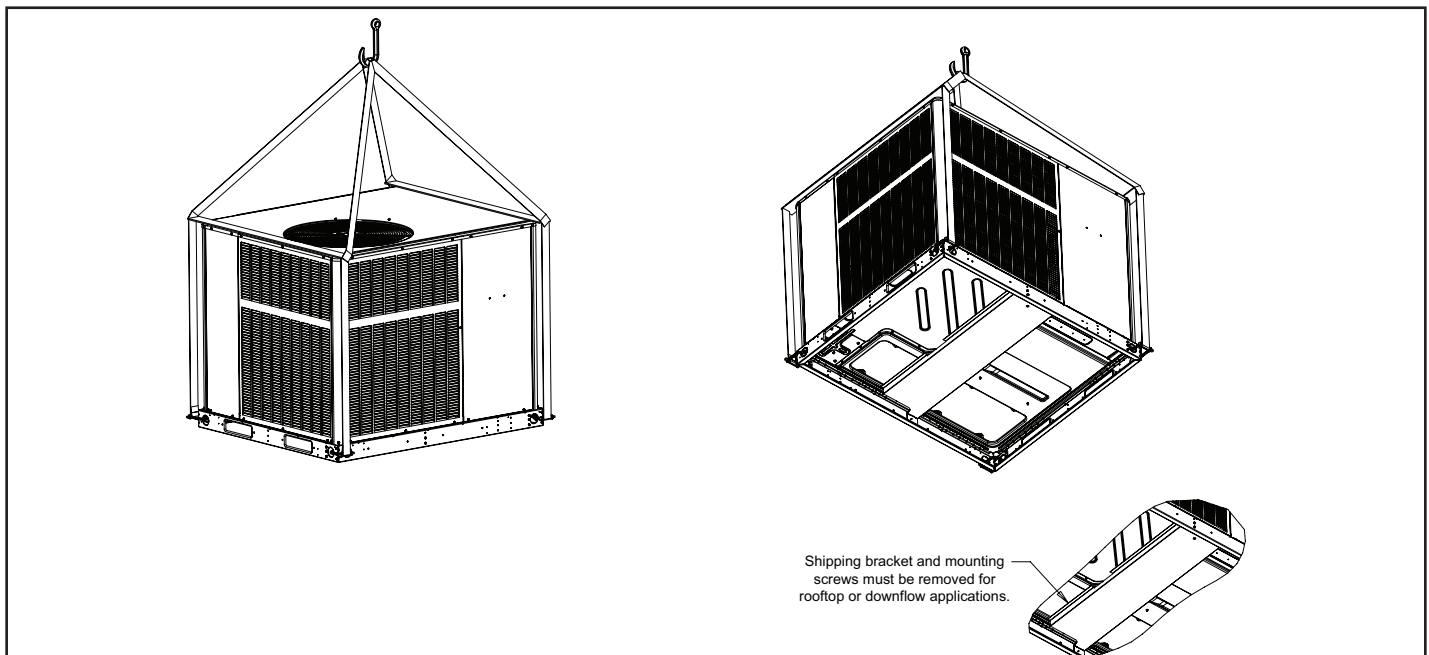

FIGURE 2

Field-Installed Economizer (Downflow)

- 1 - Before setting the unit on a roof curb, see "Roof Mounting" section for instructions on removing the shipping bracket underneath the unit.
- 2 - Remove the horizontal supply and return duct covers.
- 3 - Remove the four screws securing the downflow duct covers inside the unit. Remove and discard the covers.
- 4 - Remove the screws securing the bottom covers, and discard the bottom covers (supply and return).
- 5 - Remove screws located between the supply and return air openings that attach the blower deck to the base, and discard these screws. These screws can interfere with bottom duct connections or roof curb seals.
- 6 - Remove the close-out panel from the left-hand side of the return duct opening.
- 7 - Remove the return air panel above the return duct opening.
- 8 - Install the economizer into the unit rear panel. Wire and set up following the instructions that accompany the economizer.
- 9 - Return air duct must be field-supported.
- 10 - Unused covers and panels can be discarded.

Horizontal Air Discharge

Unit is shipped with panels covering the horizontal and downflow supply and return air openings. See FIGURE 3.

Field-Installed Economizer (Horizontal)

- 1 - Remove the horizontal duct covers over the supply and return duct openings. Covers can be discarded.

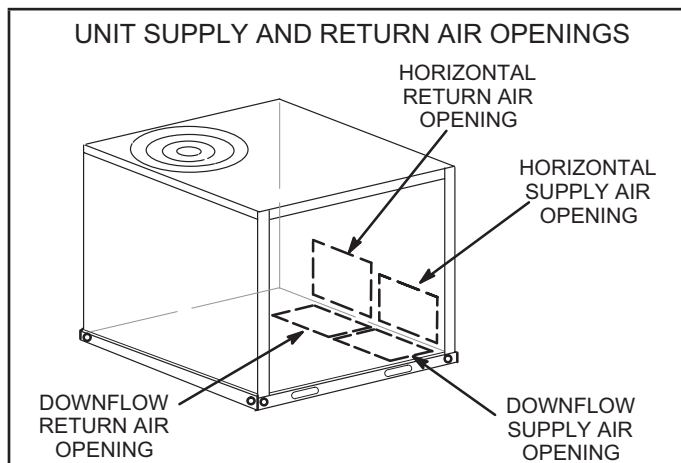

FIGURE 3

- 2 - Remove the close-out panel from the left-hand side of the return duct opening.
- 3 - Remove the return air panel above the return duct opening.
- 4 - Remove the lower (relief) hood from the economizer.

- 5 - Install the economizer into the unit rear panel. Wire and set up following the instructions that accompany the economizer.
- 6 - Install return air duct to the economizer at the former location of the relief hood.
- 7 - Cut a 20" wide X 14" high opening in the return air duct and install the economizer relief hood. See FIGURE 4.
- 8 - Return air duct must be field-supported.
- 9 - Unused covers and panels can be discarded.

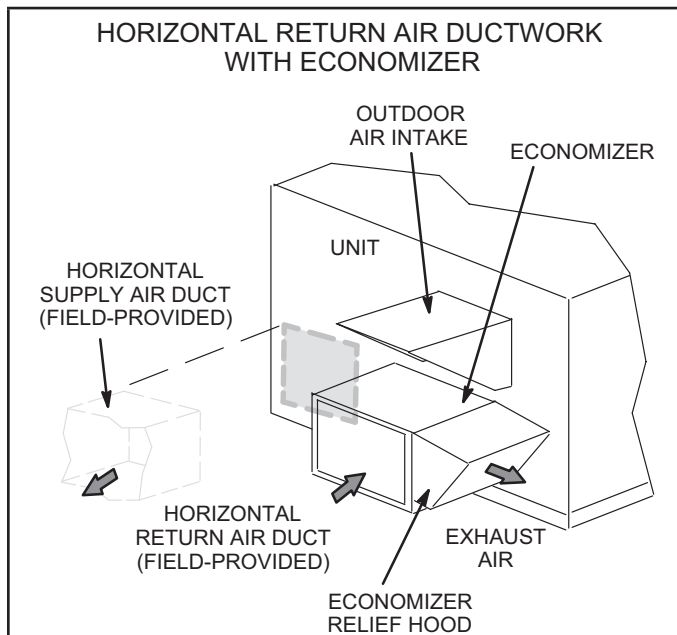

FIGURE 4

Condensate Drains

This package unit is equipped with a 3/4" FPT coupling for condensate line connection. Plumbing must conform to local codes. Use a sealing compound on male pipe threads.

Do not operate unit without a drain trap. The condensate drain is on the negative pressure side of the blower; therefore, air being pulled through the condensate line will prevent positive drainage without a proper trap. **The condensate drain line must be properly trapped, routed to a suitable drain and primed prior to unit commissioning.**

NOTE - Install drain lines and trap so they do not block service access to the unit.

See FIGURE 5 for proper drain arrangement. The drain line must pitch to an open drain or pump to prevent clogging of the line. Seal around the drain connection with suitable material to prevent air leakage into the return air system.

To prime trap, pour several quarts of water into drain, enough to fill drain trap and line.

CAUTION - Drain lines should be hand-tightened only. Do not use tools to tighten fitting into drain.

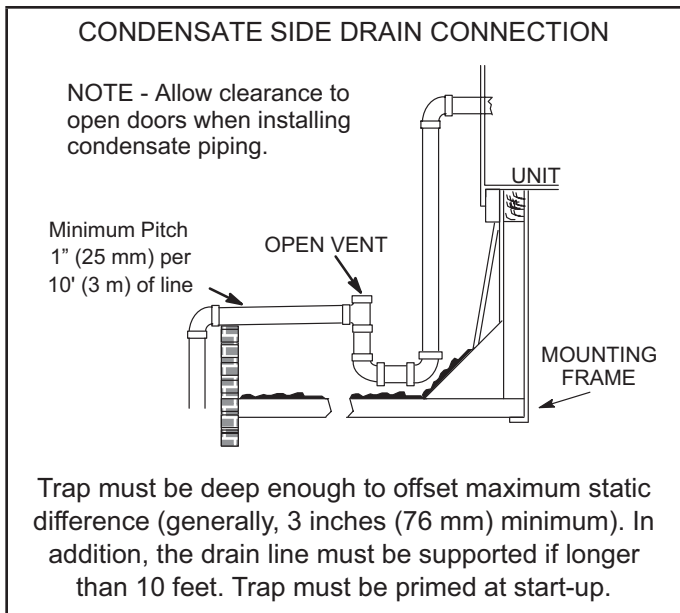

FIGURE 5

Connect Gas Piping

Before connecting field-provided piping, check with gas company or authorities having jurisdiction for local code requirements. When installing gas supply piping, length of run from gas meter must be considered in determining pipe size for 0.5" w.c. (.12kPa) maximum pressure drop. Do not use supply pipe smaller than unit gas connection. Operating pressures at the unit gas connection must be as shown in TABLE 1.

TABLE 1

OPERATING PRESSURE at GAS CONNECTION - in. w.c.

Natural Gas	
Min.	Max.
4.5	10.5

When making piping connections a drip leg should be installed on vertical pipe runs to serve as a trap for sediment or condensate. A 1/8" N.P.T. plugged tap is located on gas valve for test gauge connection. Refer to Heating Start-Up section for tap location. Install a ground joint union between the gas control manifold and the main manual shut-off valve. Piping must be installed according to allow the door to open properly.

Compounds used on threaded joints of gas piping shall be resistant to the action of liquefied petroleum gases.

The gas supply line is routed through the gas entry location on the side of the unit. See FIGURE 6. A grommet is provided in the instruction bag and should be used to seal gas supply line to gas entry of control compartment.

An optional bottom-entry gas kit is available for these units. See the instructions in that kit for proper installation details.

The gas supply line is routed through the gas entry location on the side of the unit. See FIGURE 6. A grommet is provided in the instruction bag and should be used to seal gas supply line to gas entry of control compartment.

An optional bottom-entry gas kit is available for these units. See the instructions in that kit for proper installation details.

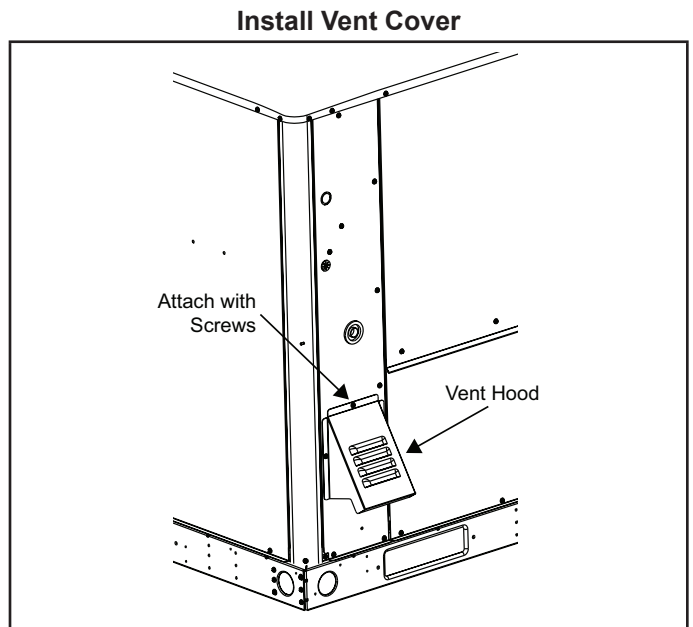

FIGURE 6

Pressure Test Gas Piping

When pressure testing gas lines, the gas valve must be disconnected and isolated. Gas valves can be damaged if subjected to more than 0.5 psig (3.48kPa). See FIGURE 7.

NOTE - Codes may require that manual main shut-off valve and union (furnished by installer) be installed in gas line external to unit. Union must be of the ground joint type.

After all connections have been made, check all piping connections for gas leaks. Also check existing unit gas connections up to the gas valve; loosening may occur during installation. Use a leak detection solution or other preferred means. Do not use matches candles or other sources of ignition to check for gas leaks.

⚠ CAUTION

Some soaps used for leak detection are corrosive to certain metals. Carefully rinse piping thoroughly after leak test has been completed. Do not use matches, candles, flame or other sources of ignition to check for gas leaks.

⚠ WARNING



Danger of explosion. Can cause injury or product or property damage. Do not use matches, candles, flame or other sources of ignition to check for leaks.

NOTE - In case emergency shut down is required, turn off the main manual shut-off valve and disconnect main power to unit. These devices should be properly labeled by the installer.

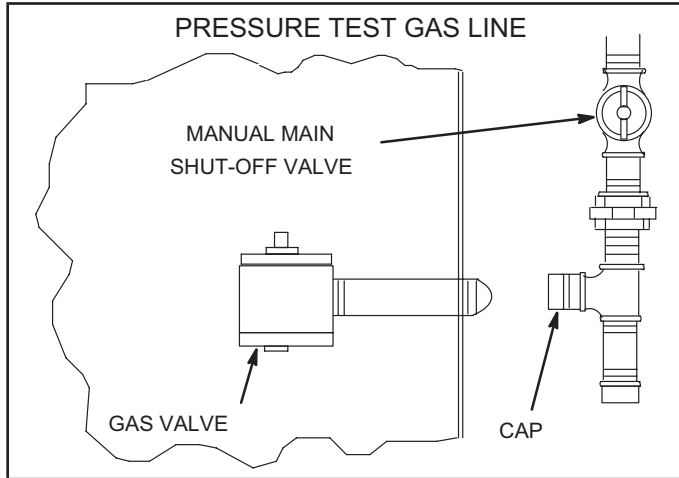

FIGURE 7

⚠ CAUTION

If a flexible gas connector is required or allowed by the authority that has jurisdiction, black iron pipe shall be installed at the gas valve and must extend outside the cabinet. The flexible connector can then be added between the black iron pipe and the gas supply line.

Install Vent Hood

The unit is shipped with the vent hood inside the return air compartment. Locate the vent hood and attach to side of utility panel with screws provided in the instruction bag. See FIGURE 6.

High Altitude Derate

Units are certified for elevations up to 4,500 feet. The input rate shown on the rating plate is for elevations up to 2000 feet. For elevations from 2001 to 4500 feet, the input rate is reduced by 5%.

Electrical Connections

All wiring should be done in accordance with the National Electrical Code, ANSI/NFPA No. 70 (latest edition); Canadian Electrical Code Part 1, CSA C22.1 (latest edition); or local codes where they prevail. Use wiring with a temperature limitation of 75°C minimum. Run the 208, 230, or 460 volt, 60 hertz electric power supply through a fused disconnect switch to the control box of the unit and connect as shown in the wiring diagram located on the inside of the control access panel.

Power supply to the unit must be N.E.C. Class 1, and must comply with all applicable codes. A disconnect switch should be field provided for the unit; follow local codes to determine what type of switch to use. The switch must be separate from all other circuits. If any of the wire supplied with the unit must be replaced, replacement wire must be of the type shown on the wiring diagram. Electrical wiring must be sized to carry minimum circuit ampacity marked on the unit. Use copper conductors only. Each unit must be wired with a separate branch circuit and be properly fused.

An optional bottom-entry power kit is available for these units. See the instructions in that kit for proper installation details.

THERMOSTAT WIRING

A - Thermostat Location

Room thermostat mounts vertically on a standard 2" X 4" handy box or on any non-conductive flat surface.

Locate thermostat approximately 5 feet (1524mm) above the floor in an area with good air circulation at average temperature. Avoid locating the room thermostat where it might be affected by:

- Drafts or dead spots behind doors and in corners
- Hot or cold air from ducts
- Radiant heat from sun or appliances
- Concealed pipes and chimneys

B - Control Wiring

- 1 - Route thermostat cable or wires from subbase to control panel (refer to unit dimensions to locate bottom and side power entry).

IMPORTANT - Unless field thermostat wires are rated for maximum unit voltage, they must be routed away from line voltage wiring.

Use 18 AWG wire for all applications using remotely installed thermostats.

- 2 - Install thermostat assembly in accordance with instructions provided with thermostat.
- 3 - Connect thermostat wiring to leads in control panel. Wire as shown in FIGURE 8.
- 4 - Four wires are required for cooling.
- 5 - A thermostat capable of two-stage cooling is required when economizers are installed.

C - Heat Anticipator

The heat anticipator setting is 0.75 amp. It is important that the anticipator setpoint be correct. Too high of a setting will result in longer heat cycles and a greater temperature swing in the conditioned space. Reducing the value below the correct setpoint will give shorter "ON" cycles and may result in the lowering of the temperature within the conditioned space.

IMPORTANT - Terminal connections at the wall plate or subbase must be made securely. Loose control wire connections may allow unit to operate but not with proper response to room demand.

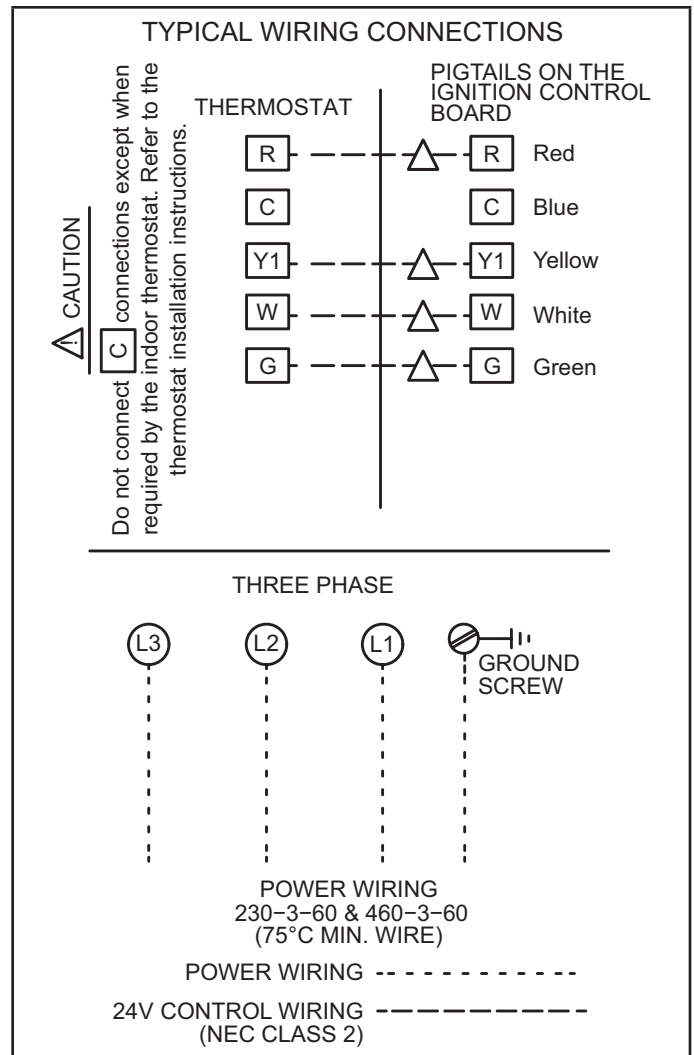

FIGURE 8

Blower Operation and Adjustments

Units are equipped with direct drive blowers.

! IMPORTANT

Three phase scroll compressors must be phased sequentially for correct compressor and blower rotation. Follow "COOLING START-UP" section of installation instructions to ensure proper compressor and blower operation.

Initiate blower demand at thermostat according to instructions provided with thermostat. Unit will cycle on thermostat demand. The following steps apply to applications using a typical thermostat.

- 1 - Blower operation is manually set at the thermostat subbase fan switch. With fan switch in **ON** position, blowers will operate continuously.
- 2 - With fan switch in **AUTO** position, the blowers will cycle with demand. Blowers and entire unit will be off when system switch is in **OFF** position.

**TABLE 2
BLOWER PERFORMANCE**

Model	Blower Tap		External Static (in.w.g.)									
			0.1	0.2	0.3	0.4	0.5	0.6	0.7	0.8	0.9	1.0
QGA036	Tap 1 Fan Only	SCFM	925	810	690	630	595	500	435	385	---	---
		RPM	566	580	601	647	688	732	769	803	---	---
		Watts	134	122	115	123	130	137	144	150	---	---
	Tap 2 Cooling (Low Static)	SCFM	1245	1210	1170	1124	1080	1040	1000	960	915	870
		RPM	711	740	769	802	829	860	890	922	952	982
		Watts	267	277	286	297	307	318	328	340	349	360
	Tap 3 Cooling (High Static)	SCFM	1515	1480	1445	1405	1375	1335	1295	1260	1225	1195
		RPM	836	862	887	910	934	958	983	1007	1033	1062
		Watts	445	456	469	481	492	503	516	526	538	553
	Tap 4 Heating (Low Static)	SCFM	975	890	840	790	735	N/A	N/A	N/A	N/A	N/A
		Rise	42	46	48	52	55	N/A	N/A	N/A	N/A	N/A
		RPM	585	609	648	688	726	N/A	N/A	N/A	N/A	N/A
		Watts	146	154	163	172	180	N/A	N/A	N/A	N/A	N/A
	Tap 5 Heating (High Static)	SCFM	N/A	1225	1180	1140	1095	1055	1015	975	935	890
		Rise	N/A	33	34	36	37	39	40	42	44	46
		RPM	N/A	749	776	806	836	866	896	926	957	987
Watts		N/A	286	296	306	317	328	339	349	359	370	
QGA042	Tap 1 Fan Only	SCFM	1115	970	800	540	460	380	315	---	---	---
		RPM	532	549	567	592	650	693	730	---	---	---
		Watts	145	132	118	98	106	113	118	---	---	---
	Tap 2 Cooling (Low Static)	SCFM	1470	1430	1380	1340	1295	1250	1205	1160	1115	1065
		RPM	659	689	721	752	784	815	847	879	911	944
		Watts	281	293	305	318	331	344	355	368	381	393
	Tap 3 Cooling (High Static)	SCFM	1755	1720	1670	1635	1595	1555	1515	1475	1435	1395
		RPM	757	784	812	838	864	892	918	944	971	998
		Watts	444	456	471	485	499	514	527	540	553	567
	Tap 4 Heating (Low Static)	SCFM	1420	1375	1325	1280	1235	1195	1145	1100	1045	N/A
		Rise	38	39	41	42	44	46	47	49	52	N/A
		RPM	640	671	706	736	770	801	834	868	904	N/A
		Watts	257	268	281	292	304	316	328	341	354	N/A
	Tap 5 Heating (High Static)	SCFM	1735	1690	1645	1605	1565	1530	1495	1450	1410	1370
		Rise	31	32	33	34	35	36	36	38	39	40
		RPM	749	778	807	834	858	886	913	940	966	993
Watts		427	442	456	471	482	497	511	524	539	552	

NOTE - All air data is measured external to unit with dry coil and without air filters.

**TABLE 2
BLOWER PERFORMANCE**

Model	Blower Tap		External Static (in.w.g.)									
			0.1	0.2	0.3	0.4	0.5	0.6	0.7	0.8	0.9	1.0
QGA048	Tap 1 Fan Only	SCFM	1230	1080	965	910	845	760	695	630	570	505
		RPM	569	582	605	645	689	736	772	810	857	895
		Watts	179	163	158	167	177	188	197	205	217	225
	Tap 2 Cooling (Low Static)	SCFM	1675	1640	1600	1560	1515	1470	1430	1390	1345	1295
		RPM	730	754	782	810	844	869	897	921	948	977
		Watts	393	403	420	432	448	460	473	485	498	512
	Tap 3 Cooling (High Static)	SCFM	1935	1895	1855	1815	1785	1745	1710	1675	1635	1595
		RPM	817	844	864	891	918	944	969	990	1012	1036
		Watts	571	587	601	615	633	648	664	674	689	702
	Tap 4 Heating (Low Static)	SCFM	1420	1370	1320	1275	1235	1190	1135	1080	1020	N/A
		Rise	38	40	41	43	44	46	48	50	53	N/A
		RPM	637	667	706	736	768	797	831	864	903	N/A
		Watts	255	266	281	291	303	313	327	339	352	N/A
	Tap 5 Heating (High Static)	SCFM	1745	1705	1660	1620	1575	1540	1500	1460	1420	1370
		Rise	31	32	33	34	34	35	36	37	38	40
		RPM	751	777	805	835	865	889	915	938	965	989
Watts		433	446	460	476	492	502	516	528	541	553	
QGA060	Tap 1 Fan Only	SCFM	1275	1230	1170	1115	1065	1000	945	865	795	735
		RPM	591	626	662	701	739	781	822	867	909	964
		Watts	181	190	199	209	220	232	242	256	267	281
	Tap 2 Cooling (Low Static)	SCFM	1880	1840	1800	1760	1715	1675	1640	1595	1555	1520
		RPM	798	824	851	874	902	929	951	979	1007	1035
		Watts	466	477	493	506	519	532	543	558	572	587
	Tap 3 Cooling (High Static)	SCFM	1790	1830	1865	1900	1945	1980	2020	2055	2095	2140
		RPM	887	911	936	951	977	1000	1026	1049	1067	1096
		Watts	652	669	683	693	709	724	740	754	765	782
	Tap 4 Heating (Low Static)	SCFM	1415	1365	1315	1260	1225	1175	1120	1065	1005	N/A
		Rise	38	40	41	43	44	46	49	51	54	N/A
		RPM	639	675	707	741	774	810	848	886	924	N/A
		Watts	230	240	252	262	273	285	298	309	322	N/A
	Tap 5 Heating (High Static)	SCFM	1745	1705	1660	1620	1575	1540	1495	1450	1410	1365
		Rise	31	32	33	33	34	35	36	37	39	40
		RPM	759	782	814	839	871	893	920	948	979	1009
Watts		391	402	416	427	442	452	464	476	490	504	

NOTE - All air data is measured external to unit with dry coil and without air filters.

TABLE 3
AIR RESISTANCE DATA - in. w.g.

Air Volume cfm	Wet Indoor Coil			Optional Economizer
	036, 042	048	060	
600	0.01	0.01	- - -	0.02
700	0.01	0.01	0.01	0.03
800	0.01	0.01	0.01	0.04
900	0.02	0.01	0.01	0.05
1000	0.02	0.02	0.02	0.06
1100	0.02	0.02	0.02	0.07
1200	0.03	0.02	0.02	0.08
1300	0.03	0.03	0.03	0.10
1400	0.04	0.03	0.03	0.12
1500	0.05	0.04	0.03	0.13
1600	0.05	0.05	0.03	0.15
1700	0.05	0.05	0.04	0.18
1800	0.06	0.05	0.04	0.20
1900	0.06	0.06	0.04	0.21
2000	0.07	0.06	0.05	0.24

Cooling Start-Up

A - Operation

- 1 - Initiate cooling demands according to instructions provided with thermostat.
- 2 - When the thermostat calls for cooling, R is closed to Y (see the wiring diagrams). This action completes the low voltage control circuit, energizing the compressor, condenser fan motor, and blower motor.
- 3 - Unit compressors have internal protection. In the event there is an abnormal rise in the temperature of the compressor, the protector will open and cause the compressor to stop.
- 4 - The combustion air inducer operates for the first 10 seconds of every cooling cycle to prevent insects from nesting in the flue outlet.

Blower Delay – Cooling

The circulating air blower is controlled by a timing circuit in the integrated blower/ignition control. Timings are not adjustable. Blower “ON” delay is 5 seconds after the compressor starts and blower “OFF” timing is 60 seconds after the compressor shuts down.

NOTE- - There is no blower OFF delay when there is a call for G (fan only).

Continuous Fan

With the proper thermostat and sub-base, continuous blower operation is possible by closing the R to G circuit. Cooling blower delay is also functional in this mode.

- 5 - Units contain one refrigerant circuit or stage.
- 6 - Unit is charged with R-410A refrigerant. See unit rating plate for correct amount of charge.
- 7 - Refer to Refrigerant Charge and Check section for proper method to check refrigerant charge.

B - Three-Phase Scroll Compressor Voltage Phasing

Three phase scroll compressors must be phased sequentially to ensure correct compressor and blower rotation and operation. Compressor and blower are wired in phase at the factory. Power wires are color-coded as follows: line 1-red, line 2-yellow, line 3-blue.

- 1 - Observe suction and discharge pressures and blower rotation on unit start-up.
- 2 - Suction pressure must drop, discharge pressure must rise and blower rotation must match rotation marking.

If pressure differential is not observed or blower rotation is not correct:

- 3 - Disconnect all remote electrical power supplies.
- 4 - Reverse any two field-installed wires connected to the line side of contactor.

- 5 - Make sure the connections are tight.

Discharge and suction pressures should operate at their normal start-up ranges.

C - Refrigerant Charge and Check

WARNING-Do not exceed nameplate charge under any condition.

This equipment is a self-contained, factory-optimized refrigerant system. The unit should not require adjustments to system charge when properly installed. If unit performance is questioned, perform the following checks.

Ensure unit is installed per manufacturers instructions and that line voltage and air flow are correct. Refer to TABLE 4 for proper performance value. The indoor metering device varies by model. When checking performance of a unit using an orifice for metering, refer to the suction superheat value to judge performance. When checking performance of a unit that uses an expansion valve for metering, refer to the subcooling value to judge system performance.

If the measured performance value varies from table value allowance, check internal seals, service panels and duct work for air leaks, as well as restrictions and blower speed settings. If unit performance remains questionable, remove system charge, evacuate to 500 microns, and weigh in refrigerant to nameplate charge. It is critical that the exact charge is re-installed. Failure to comply will compromise system performance.

If unit performance is still questionable, check for refrigerant-related problems, such as blocked coil or circuits, malfunctioning metering device or other system components.

TABLE 4

COOLING SYSTEM PERFORMANCE VALUES

Model	Suction Superheat +/- 3	Liquid Subcooling +/- 2
3 Ton	14	
3.5 Ton	14	
4 Ton	16	
5 Ton	17	

Based on outdoor ambient temperature of 82°F and indoor entering air of 80°F db / 6°F wb.

TABLE 5
COOLING PERFORMANCE

80°F DB / 67°F WB Return Air		Air Temperature Entering Outdoor Coil, °F											
Cooling Input (1000 BTU)	Pressure	65	70	75	80	82	85	90	95	100	105	110	115
36	Suction	135	137	140	142	143	144	147	149	151	152	154	155
42		129	132	135	139	140	141	143	145	146	147	148	149
48		132	136	139	143	144	145	146	147	149	151	152	154
60		130	131	133	134	135	136	139	141	144	146	149	152
36	Liquid	250	275	301	326	336	351	375	399	423	446	470	493
42		248	271	293	316	325	339	362	385	411	436	462	487
48		265	286	308	329	338	352	376	400	427	455	482	509
60		256	276	296	316	324	340	365	386	415	438	473	503

D - Compressor Controls

See unit wiring diagram to determine which controls are used on each unit. Optional controls are identified on wiring diagrams by arrows at junction points.

1 - High Pressure Switch (S4)

The high pressure switch is an auto-reset SPST N.C. switch which opens on a pressure rise.

S4 is located in the compressor discharge line and is wired in series with the compressor contactor coil.

When discharge pressure rises to 590±10 psig (4068±69kPa), indicating a problem with the system, the switch opens. The respective compressor is de-energized but the economizer can continue to operate. Auto-reset switches close at 418±20psig (2882±138kPa).

2 - Compressor High Temperature Limit (S173)

The temperature limit switch S5 is located on the top of Interlink compressors and is wired in series with the high pressure switch S4.

Gas Heat Start-Up

FOR YOUR SAFETY READ BEFORE LIGHTING

⚠ WARNING



Electric shock hazard. Can cause injury or death. Do not use this unit if any part has been under water. Immediately call a qualified service technician to inspect the unit and to replace any part of the control system and any gas control which has been under water.

⚠ WARNING



Danger of explosion. Can cause injury or product or property damage. If overheating occurs or if gas supply fails to shut off, shut off the manual gas valve to the appliance before shutting off electrical supply.

⚠ WARNING



Electric shock hazard. Can cause injury or death. Before attempting to perform any service or maintenance, turn the electrical power to unit OFF at disconnect switch(es). Unit may have multiple power supplies.

⚠ WARNING

SMOKE POTENTIAL

The heat exchanger in this unit could be a source of smoke on initial firing. Take precautions with respect to building occupants and property. Vent initial supply air outside when possible.

BEFORE LIGHTING smell all around the appliance area for gas. Be sure to smell next to the floor because some gas is heavier than air and will settle on the floor.

The gas valve may be equipped with either a gas control lever or gas control knob. Use only your hand to push the lever or turn the gas control knob. Never use tools. If the lever will not move or the knob will not push in or turn by hand, do not try to repair it. Call a qualified service technician. Force or attempted repair may result in a fire or explosion.

⚠ WARNING



Danger of explosion. Can cause injury or death. Do not attempt to light manually. Unit has a direct spark ignition system.

This unit is equipped with an automatic spark ignition system. There is no pilot. In case of a safety shutdown, move thermostat switch to **OFF** and return the thermostat switch to **HEAT** to reset ignition control.

A - Placing Unit In Operation

⚠ WARNING



Danger of explosion and fire. Can cause injury or product or property damage. You must follow these instructions exactly.

Gas Valve Operation

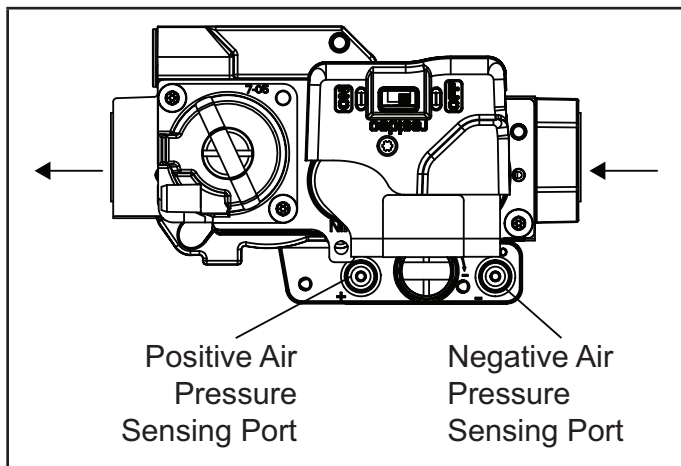

FIGURE 9

To Light Main Burner

- 1 - Turn off electrical power to unit.
- 2 - Turn the thermostat to lowest setting.
- 3 - Slide the gas valve switch to the “ON” position (see FIGURE 9).
- 4 - Turn on electrical power to the unit.
- 5 - Set the room thermostat to the desired temperature. (If the thermostat “set” temperature is above room temperature after the pre-purge time expires, main burner will light).

To Shut Down Main Burner

- 1 - Turn off electrical power to unit.
- 2 - Slide the gas valve switch to the “OFF” position (see FIGURE 9).

⚠ WARNING



Danger of explosion. Can cause injury or death. Do not attempt to light manually. Unit has a direct spark ignition system.

Gas Manifold Pressure Check

For purposes of this measurement, the minimum permissible gas supply pressure is 5 “w.c. for natural gas.

To verify this pressure:

- 1 - Slide the gas valve switch to the “OFF” position (see FIGURE 9).
- 2 - Remove plug on valve marked “OUTLET PRESSURE”.
- 3 - Install a water manometer.
- 4 - Slide the gas valve switch to the “ON” position and initiate a call for heat. During steady state operation, manifold pressure should be:

Manifold Pressure (non-adjustable)	2.7 - 3.1 “ w.c.
------------------------------------	------------------

- 5 - After verifying pressure, turn gas off, remove manometer fitting, and replace pipe plug and regulator cap.
- 6 - Put furnace in operation and check plug for leaks using soapy solution.

Heating Operation and Adjustments

A - Heating Sequence of Operation

When the thermostat calls for heating, R is closed to W. The following describes the gas heating sequence of operation.

- 1 - A call for heat from the room thermostat signals the ignition control to energize the combustion air blower at ignition speed.
- 2 - When the speed of the combustion air blower reaches proper RPM, the pressure switch closes, initiating a pre-purge period (30 seconds nominal).
- 3 - When the pre-purge period has expired, the ignition control energizes the main gas valve and spark electrode for a period of 10 seconds. Combustion air blower ramps to continuous run speed.
- 4 - If the flame sensor does not sense that a flame has been established in the 10-second interval, then the ignition control will de-energize the gas valve, and begins a 30 second inter-purge period, then initiates another trial for ignition.
- 5 - The ignition control is designed to repeat this "trial for ignition" a total of three times. If, at the end of the third trial, flame still has not been established, then the ignition control will try to light again 1 hour later. The 1-hour retry is indefinite. The ignition control can be reset by interrupting the unit power or the thermostat circuit.
- 6 - Once flame sense has been established, the circulating air blower is energized after a 30 second blower on delay.
- 7 - When the thermostat is satisfied, the combustion air blower and gas valve are de-energized. The circulation air blower will continue to run for a short period after the furnace is shut down.

B - Safety Controls

The control circuit includes the following safety controls:

Limit Control

This control is located inside the heating compartment and is designed to open at abnormally high circulating air temperatures. It resets automatically. The limit control operates when a high temperature condition, caused by inadequate airflow, occurs. This closes the main gas valve.

Pressure Switch

If the combustion air blower should fail, the pressure switch prevents the spark electrode and gas valve from being energized.

Flame Sensor

If the ignition control does not receive a signal from the flame sensor indicating that the burners have established flame, the gas valve closes after the 10-second trial for ignition period.

Burner Temperature Switch

The burner temperature switch is located on the combustion air intake elbow adjacent to the gas manifold. In the event of excessive burner heat, the switch shuts off the ignition control and closes the main gas valve. The switch resets automatically.

Blower Delay – Heating

- The circulating air blower "ON" delay is 30 seconds after "W" signal is received to allow the furnace to warm up.
- The circulating air blower "OFF" delay is 180 seconds after shutting down the burners. This delay is not adjustable.

NOTE - 120 second OFF delay for 460V models

C - Ignition Control Diagnostic LEDs

TABLE 6

IGNITION CONTROL HEARTBEAT LED STATUS

LED Status	Flashing Rate	Fault Description
Slow Flash	One flash per second	Normal operation: No call for heat.
Fast Flash	Two flashes per second	Normal operation: Call for heat.
2	Two flashes in 1 second with 1-second pause	System lockout: Failed to detect or sustain flame.
3	Three flashes in 1.5 seconds with 1-second pause.	Pressure switch senses incorrect pressure or gas valve coil is open.
4	Four flashes in 2 seconds with 1-second pause	High limit or roll-out switch open
5	Five flashes in 2.5 seconds with 1-second pause	Flame sensed and gas valve not energized.
Steady Off		Internal failure: Micro-controller failure; self-check

D - Limit Controls

Limit controls are factory-set and are not adjustable. The primary limit is located in the heating compartment near the supply duct.

If the primary limit trips three times in the same heating cycle, heating operation will de-energize. Heating will automatically restart after one hour if a heating demand is present. To initiate heating during the one hour timed-off interval, reset the thermostat.

E - Heating Adjustment

Main burner is factory-set and does not require adjustment.

Service

The unit should be inspected once a year by a qualified service technician.

⚠ CAUTION

Label all wires prior to disconnection when servicing controls. Wiring errors can cause improper and dangerous operation. Verify proper operation after servicing.

A - Filters

Air filters are not supplied with the unit. A field-provided air filter must always be installed ahead of the evaporator coil and must be cleaned or replaced if necessary. Dirty filters will reduce the airflow of the unit. All units are equipped with a factory-installed filter rack. Use two 20 X 20 X 1" (508 X 508 X 51mm) filters. Refer to local codes or appropriate jurisdiction for approved filters.

To change filters, remove the blower access panel and slide the filters out of the internal rack. See FIGURE 10.

Approved filters should be checked monthly and replaced when necessary. Take note of air flow direction marking on filter frame when reinstalling filters.

NOTE - Filters must be U.L.C. certified or equivalent for use in Canada.

An optional tool-less filter access kit is available. The kit includes two new blower panels (one smaller panel secured with screws, the other with twist latches) to provide access for filter changes without any hand tools.

B - Lubrication

All motors are lubricated at the factory. No further lubrication is required.

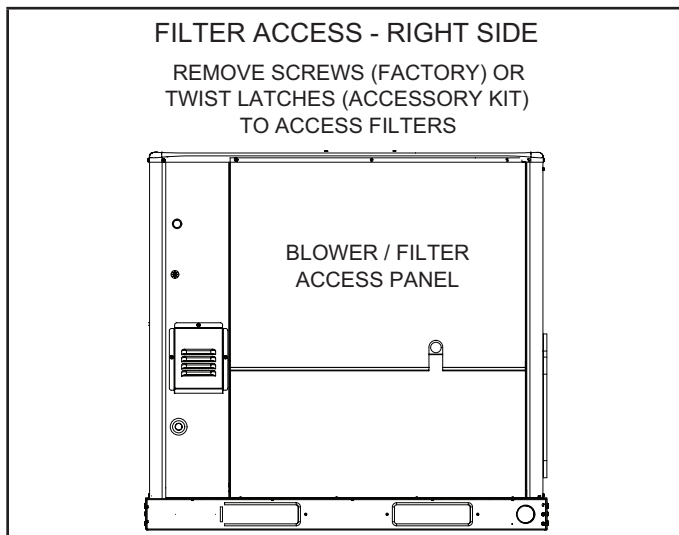

FIGURE 10

C - Combustion Air Intake

Ensure sufficient combustion air is available to the burners. Clean combustion air intake screen and clear debris from vestibule compartment louvers and unit exterior louver panels.

⚠ WARNING



Danger of explosion. Can cause injury or death. Do not overtighten main burner mounting screws. Snug tighten only.

D - Combustion Air Inducer

A combustion air proving switch checks combustion air inducer operation before allowing power to the gas controller. Gas controller will not operate if inducer is obstructed.

Under normal operating conditions, the combustion air inducer wheel should be checked and cleaned prior to the heating season. However, it should be examined periodically during the heating season to establish an ideal cleaning schedule.

Clean combustion air inducer as follows:

- 1 - Shut off power supply and gas to unit.
- 2 - Remove the control access panel located on the front right side of the unit.
- 3 - Remove and retain the screws securing the vent hood to the utility panel.
- 4 - Remove and retain the screws securing the flue choke to the outside of the utility panel.
- 5 - Remove and retain the screw securing the flue tube from the inducer outlet.
- 6 - Remove and retain screws securing combustion air inducer to flue box.
- 7 - Clean inducer wheel blades with a small brush and wipe off any dust from housing. Take care not to damage exposed fan blades. Clean accumulated dust from front of flue box cover.
- 8 - Return combustion air inducer motor, flue tube, flue choke, and vent hood to original locations and secure with retained screws. It is recommended that gaskets be replaced during reassembly.
- 9 - Replace the access panel.

E - Flue Box and Heat Exchanger

With proper combustion adjustment, the heat exchanger of a gas-fired furnace will seldom need cleaning. Sooting of a gas appliance is highly irregular and once cleaned, the cause of the sooting must be determined. If the heat exchanger should become sooted, it can be cleaned as follows:

- 1 - Remove the burner assembly as outlined in the Burner and Burner Orifice Instructions section.
- 2 - Remove the combustion blower.
- 3 - At the bottom of the heating section, remove the screws holding the flue collector box. Carefully remove the flue collector box without ripping the adjacent insulation.
- 4 - Using a wire brush on a flexible wand, brush out the inside of each heat exchanger from the burner inlet and flue outlet ends.
- 5 - Brush out the inside of the flue collector box.
- 6 - Run the wire brush down the heat exchanger tubes from the flue collector end.
- 7 - If soot buildup is excessive, remove the vent motor and clean the wheel and housing. Run the wire brush down the flue extension at the outlet of the vent housing.
- 8 - After brushing is complete, blow all brushed areas with air. Vacuum as needed.
- 9 - Replace parts in the reverse order they were removed in Steps 1 through 3.
- 10 - When replacing the flue collector box, be careful so as not to tear the adjoining insulation.
- 11 - Assure that all joints on the vent side of the combustion system are air tight. Apply a high temperature (+500°F) sealing compound where needed.

F - Evaporator Coil

Inspect and clean coil at beginning of each cooling season. Clean using mild detergent or commercial coil cleaner. Flush coil and condensate drain with water taking care not to get insulation, filters and return air ducts wet.

G - Condenser Coil

Clean condenser coil annually with water and inspect monthly during the cooling season.

H - Compressor

⚠ IMPORTANT

Some scroll compressors have an internal vacuum protector that will unload scrolls when suction pressure goes below 20 psig. A hissing sound will be heard when the compressor is running unloaded. Protector will reset when low pressure in system rises above 40 psig. **DO NOT REPLACE COMPRESSOR.**

I - Supply Air Blower Wheel

Annually inspect supply air blower wheel for accumulated dirt or dust. Turn off power before attempting to remove blower access panel or to clean blower wheel.

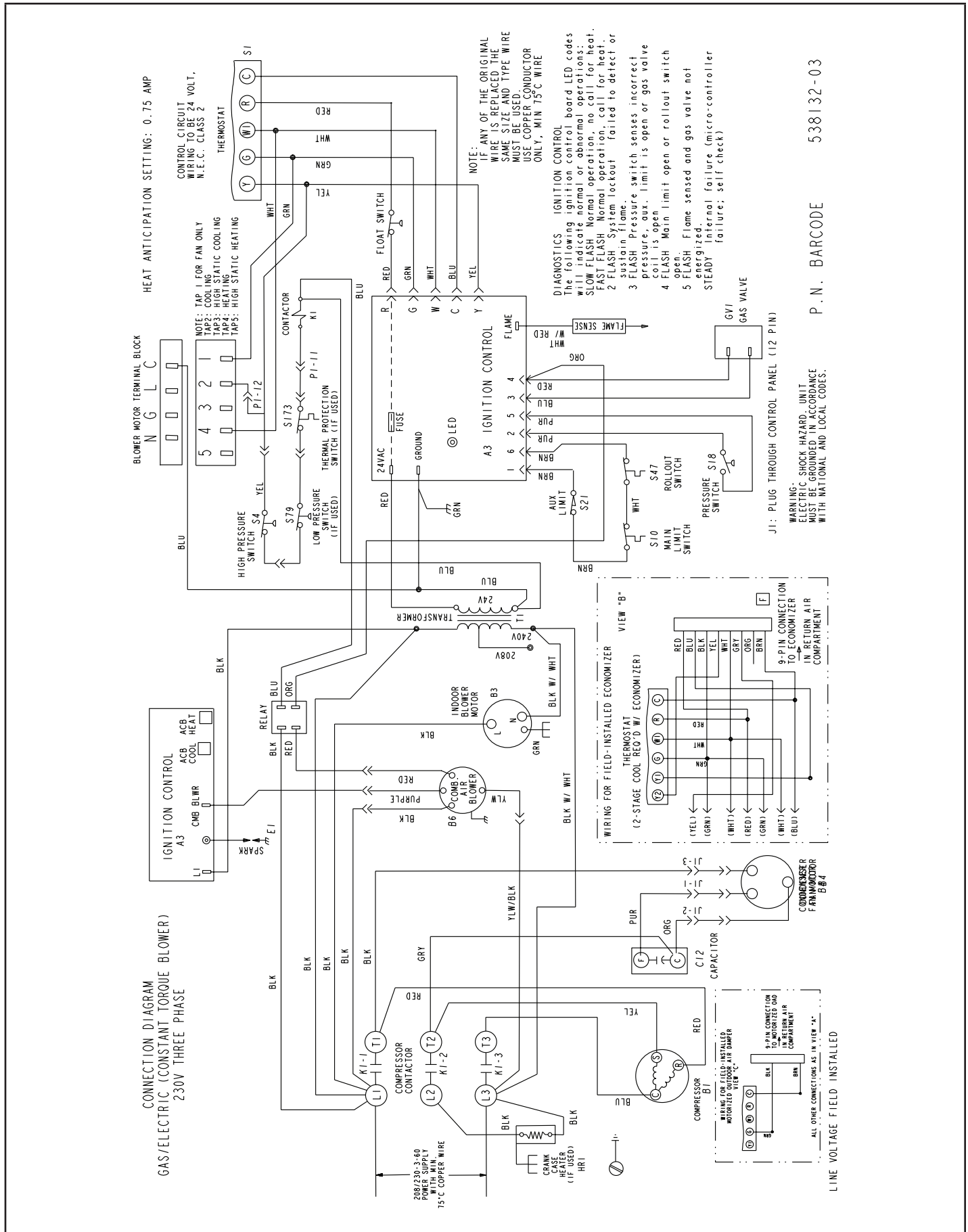

P. N. BARCODE 538132-03

FIGURE 11

Start-Up Report

Job Name: _____
 Store No. _____ Start-Up Date: _____
 Address: _____
 City: _____ State: _____
 Start-Up Contractor: _____
 Technician: _____
 Model No. _____
 Serial No. _____
 RTU No. _____ Catalog No. _____

Inspection and Checks

Damage? Yes No R22 R-410A
 If yes, reported to: _____

 Verify factory and field-installed accessories.
 Check electrical connections. Tighten if necessary.
 Supply voltage: L1-L2 _____ L1-L3 _____ L2-L3 _____
 If unit contains a 208-230/240 volt transformer:
 Check primary transformer tap
 Transformer secondary voltage: _____

Cooling Checks

Compressor Rotation Ambient Temp. _____ Return Air Temp. _____ Supply Air Temp. _____

	Compressor Amps			Compressor Volts			Pressures		Condenser Fan Amps			CC Heater Amps
	L1	L2	L3	L1-L2	L1-L3	L2-L3	Disch.	Suct.	L1	L2	L3	L1
1												
2												
3												
4												

Blower Checks

Pulley/Belt Alignment Blower Rotation
 Set Screws Tight Belt Tension
 Nameplate Amps: _____ Volts: _____

Motor	Amps	Volts
_____	L1 _____	L1-L2 _____
_____	L1 _____	L1-L2 _____
_____	L1 _____	L1-L2 _____

Heating Checks - Electric

Return Air Temp. _____ Supply Air Temp. _____
 Limits Operate:

	Amps						
	L1	L2	L3		L1	L2	L3
1				10			
2				11			
3				12			
4				13			
5				14			
6				15			
7				16			
8				17			
9				18			

Heating Checks - Gas

Fuel type: Nat. LP Inlet Pressure (in. w.c.): _____
 Return Air Temp. _____ Supply Air Temp. _____
 Altitude: _____ Primary Limits Operate:

Gas Valve	Manifold Pressure	
	Low Fire	High Fire
GV1		
GV1		

Control Type

Accessory Checks

Economizer Operation
 Min. Pos. Motor Travel full open/close