

# PrimeLink™ C9070 / C9065 Printer

Simply professional. Amazingly flexible.



# Versatility from your all-in-one solution to suit all professionals

Your teams require the flexibility and productive workflow of a multifunction device. Your graphics, creative and production teams want a higher level of quality and finishing. However, purchasing machines to satisfy each requirement may become costly and space consuming. PrimeLink C9070 / C9065 Printer can be your "all-in-one" solution that flexibly meets the demands of professionals while offering a multitude of functions for the efficiency and versatility of your office work environment.

## OFFERING VERSATILITY WITH VARIOUS FEATURES

PrimeLink C9070 / C9065 Printer will assist your professional requirements with a variety of features that supports creativity and innovation of your professional work. While offering functions such as density uniformity/alignment adjustments and colour calibration, its variety of finishing options and efficiency-boosting workflows will keep jobs moving with less wasted time and materials.

To cater for your office work needs, this versatile printer also allows you to print, copy and scan - including automatic sending of scanned data to your PC, sending by e-mail or printing from USB. It can even print from virtually any smartphone or tablet. That's how the PrimeLink C9070 / C9065 Printer will boost any team's efficiency.

## EQUIPPED WITH FEATURES TO ACCELERATE YOUR NEW BUSINESS POTENTIAL WITH IN-HOUSE COLOUR PRINTING

- Productive print speeds – print up to 70/65 ppm in colour and up to 75/70 ppm in black-and-white. With easy set-up and automated workflows, you can handle quick turnarounds in style.
- Media versatility – both coated and uncoated stocks up to 350 gsm are supported, including a variety of paper sizes such as postcards and banners.
- Wider finishing capabilities – a variety of inline finishing options offers a professional polish to presentation materials, brochures, reports and documents that require an extra appeal. Finishers include numerous functions like stapling, punching, folding, creasing, full bleed trimming and booklet making.
- Workflow innovation – integration with FreeFlow Digital Workflow Collection and partner solutions that deliver workflow productivity, innovation and automation. It also enables variable data solutions designed to meet a customer's demand for

## PrimeLink C9070 / C9065 Printer QUICK FACTS

### Speed

Up to 70/65 ppm colour and 75/70 ppm black-and-white

### Single-pass scanner

Up to 270 images per minute (ipm)

### Printing resolution

2400 × 2400 dpi

### Toner

Fuji Xerox Emulsion Aggregation (EA) Toner with ultra-low melt technology

### Media weights

Up to 350 gsm and up to 256 gsm\* for auto duplexing

### Media sizes

Up to 330 × 660 mm

\* For 221 to 256 gsm, print results are not fully assured.



## For graphic arts Features to expand your creativity and efficiencies

### WIN WITH SPEED AND IMAGE QUALITY

PrimeLink C9070 / C9065 Printer comes standard with a print server, which is ideal for professional and quick-print environments, supporting job workflows, colour management and any finishing requirements.

### SUPPORT FOR BANNER PRINTING

You can print on larger media with the PrimeLink C9070 / C9065 Printer, it is capable of handling paper sizes up to 660 mm in length. Perfect for banners.

### A WIDE RANGE OF OPTIONS FOR A WIDER VARIETY OF FINISHED JOBS

As your number of incoming jobs grow from a handful to dozens or even hundreds a day and as they come in more shapes and sizes streamlining manual labour is essential. PrimeLink C9070 / C9065 Printer offers a wider variety of finishing options to provide automation that keeps you productive whilst saving time and reducing costly errors.



## For corporate applications Latest office supporting technologies to accelerate your business activities

### Portable UI for Business\*\*

Your smartphone (iOS and Android™) can be used as a portable UI panel. Simply set a job on your smartphone and touch the NFC (Near Field Communication) reader\*<sup>2</sup> on the multifunction device to perform basic operations such as copy and scan (Store-to-Folder or E-mail). Portable UI for business enables up to 30 frequently used settings to be registered as favourites. These settings can be recalled with a single touch. The destination for saving scanned data can also be registered for added convenience.

\*1: A wireless environment with an access point is required.  
\*2: IC Card Reader is required.

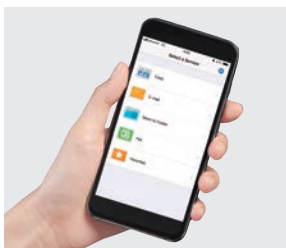

### Print Utility

Fuji Xerox Print Utility enables users to print directly from iOS or Android™ devices, putting mobile printing and scanning convenience at your fingertips. Print stored photo albums, web pages or shoot and print on the go from your iOS or Android™ device. Simply wave your NFC enabled mobile device on the

PrimeLink™ C9070 / C9065 to automatically launch Print Utility and you are ready to print or scan.

### Wi-Fi Direct®

Even when your intranet environment cannot be used by a visiting or employee's mobile device, these devices can connect to the PrimeLink C9070 / C9065 printer via a wireless kit\* to print documents. In addition to printing and scanning with Print Utility, AirPrint, Google Cloud Print™ and Mopria® are also supported.

\* Optional.



### Simple scanning for workflows\*

Convert scanned documents automatically to a pre-specified file format and destination. Once a file format and destination is registered, select the workflow button and scan the document. Add a file name by adding a document type and date to a user-defined string set on a PC. Efficiency is dramatically increased when managing contracts and bills.

\* Optional.

### Server-less on-demand printing\*

Combine greater security, convenience and reduce costs with server-less on-demand printing. Check the status of your print job on the UI panel before printing using the preview displays, or change settings such as the number of copies, colour mode and one-sided/ two-sided output, all from the UI panel. This improves document security and reduces waste from unnecessary printing.

\* Optional.



Offering a myriad of standard functions to support your creativity and work efficiency.

**INNOVATION COMES STANDARD**

**Vibrant colour and incredible detail**

With our 2400 x 2400 DPI printing resolution, images are rich with crisp text so your output will always impress.

**Excellent image quality**

Our Emulsion Aggregation Toner with ultra-low melt technology is chemically grown, so the small, consistent particles produce impeccable quality with smooth transitions and an offset-like finish.

**CLEAR PRINTING OF SMALL TEXT AND THIN LINES**

**Edge enhancement**

Jaggedness, which tends to occur with mid-tone texts and lines, is suppressed by using screen processing on contours to reproduce crisp text and lines.

**Adjust Invert Text/Line Weight**

PrimeLink C9070 / C9065 Printer mitigates the crushing of white texts and fattening of small black texts. Several levels of toner are available to apply to the contour, so that you can set a desirable balance for improved text readability.

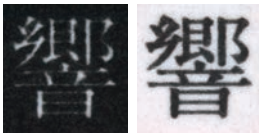

Adjust Invert Text/Line Weight: Off

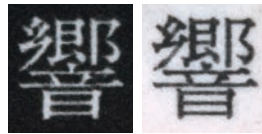

Adjust Invert Text/Line Weight: On

**SELECT DIFFERENT SCREENS FOR INDIVIDUAL OBJECTS**

Various screens can be chosen according to the objects you use, such as text and photos.

**TRUE Adobe® PostScript® 3™ CERTIFICATION AND THE LATEST Adobe® PDF Print Engine\***

These features plus lightning speeds means your creativity is never compromised.

\* Adobe® PDF Print Engine is Optional.



Adobe PostScript® 3™



Adobe PDF Print Engine 4

**CONTROL QUALITY AND SAVE TIME WITH ADVANCED SIQA\***

Advanced SIQA can save you from the hassle of adjusting alignment, density uniformity, tonal reproduction curve or transfer voltage. By simply scanning the printed charts, advanced SIQA will optimise the adjustment values. With advanced SIQA, operators no longer have to go through the time-consuming and repetitive procedure of having to print, measure and manually adjust individual settings. PrimeLink C9070 / C9065 Printer reduces waste and a considerable amount of operator intervention while consistently exceeding image quality expectations.

\* Simple Image Quality Adjustment.

**GX-i Print Server for the PrimeLink C9070 / C9065 Printer**

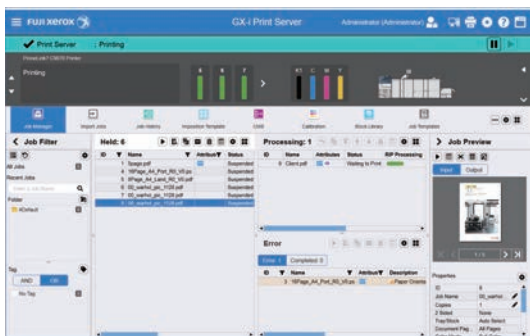

**Superb speed and image quality**

Featuring a simple user interface, versatile media handling and automated RGB colour correction, this GX-i Print Server utilises architecture developed by Fuji Xerox to reduce RIP load and a RIP Accelerator Board to maintain image quality through high-speed, lossless compression.







# Lineup of optional feeders and finishers to widely accommodate your needs.

## FEEDING OPTIONS

	<p><b>HCF B1</b> Adds 2000 sheets of A4 (up to 220 gsm).</p>		<p><b>High Capacity Feeder B1-S</b> Adds 2000 sheets in sizes of up to 330 x 488 mm (up to 350 gsm). Storage cabinet included.</p> <p><a href="#">Air Assist</a> <a href="#">Multifeed Detection</a></p>		<p><b>High Capacity Feeder C1-DS</b> Adds 4000 sheets in sizes of up to 330 x 488 mm (up to 350 gsm).</p> <p><a href="#">Air Assist</a> <a href="#">Multifeed Detection</a></p>
---	--	---	--	--	---

Note: Long paper is fed from the Bypass Tray (standard). When High Capacity Feeder B1-S or High Capacity Feeder C1-DS is connected, Bypass Tray is detached from the printer and attached to the connected High Capacity Feeder.













## FINISHING OPTIONS

				
<p><b>C3 Finisher, or C3 Finisher with Booklet Maker<sup>1</sup></b></p> <p><a href="#">Sort/Stack</a> <a href="#">Staple</a> <a href="#">Punch<sup>5</sup></a> <a href="#">Saddle Staple/Single Fold<sup>6</sup></a> <a href="#">Z-Fold/Tri-Fold<sup>6</sup></a></p>	<p><b>Inserter D1<sup>2</sup></b></p> <p><a href="#">Cover/Sheet Insertion</a></p>	<p><b>Crease/Two-sided Trimmer D2<sup>2</sup></b></p> <p><a href="#">Two-Sided Trim</a> <a href="#">Crease</a></p>	<p><b>Finisher D6, Finisher D6 with Booklet Maker, or Finisher D6 Plus<sup>3</sup> Coming soon</b></p> <p><a href="#">Sort/Stack</a> <a href="#">Staple</a> <a href="#">Punch<sup>5</sup></a> <a href="#">Saddle Staple/Single Fold<sup>6</sup></a> <a href="#">Z-Fold/Tri-Fold<sup>6</sup></a></p>	<p><b>SquareFold Trimmer D1<sup>4</sup></b></p> <p><a href="#">Face Trim</a> <a href="#">Square Fold</a></p>

Note: Offset Catch Tray and Simple Catch Tray are provided for cases that do not require finishing. For third party vendor finishers, please contact your local Fuji Xerox representative.

<sup>1</sup>: Transport Unit V1 is required.  
<sup>2</sup>: Finisher D6, Finisher D6 with Booklet Maker or Finisher D6 Plus is required.  
<sup>3</sup>: Interface Decurler Module D1 is required.  
<sup>4</sup>: Finisher D6 with Booklet Maker is required.  
<sup>5</sup>: Optional.  
<sup>6</sup>: For C3 Finisher with Booklet Maker or Finisher D6 with Booklet Maker.

## FINISHING APPLICATIONS

		
Cover/Sheet Insertion	Punch	Staple
		
Saddle Staple	Booklet	Z-Fold
		
Tri-Fold	Crease	Face Trim
		
Two-Sided Trim	Full Bleed Trim	Square Fold



Note: Full bleed trim is made by two-sided trim and face trim.

# PrimeLink C9070 / C9065 Printer Functions & Specifications

## Basic Specifications / Print Function

Item		Description	
		PrimeLink C9070 Printer	PrimeLink C9065 Printer
Colour Capability		Full Colour	
Printing Resolution		2400 x 2400 dpi	
Continuous Print Speed <sup>1</sup>	A4	B/W: 75 ppm Colour: 70 ppm	B/W: 70 ppm Colour: 65 ppm
	A3	B/W: 37 ppm Colour: 35 ppm	B/W: 35 ppm Colour: 33 ppm
Paper Size <sup>2</sup>	Tray 1	Standard Size: Max A3, Min A5 Custom Size: 140 x 182 mm to 330 x 458 mm	
	Tray 2	Standard Size: Max A3, Min A5 Custom Size: 140 x 182 mm to 297 x 432 mm	
	Tray 3, 4	Standard Size: A4, JIS B5	
	Bypass Tray	Standard Size: Max A3, Min A6 Custom Size: 100 x 148 mm to 330 x 660 mm	
Paper Weight	Tray 1, 2, 3, 4	60 to 256 gsm	
	Bypass Tray	60 to 350 gsm <sup>3</sup>	
Paper Tray Capacity <sup>4</sup>	Standard	500 sheets x 2 -tray + 870 sheets + 1140 sheets + Bypass Tray 250 sheets	
	Optional	HCF B1: 2000 sheets x 1 -tray High Capacity Feeder B1-S: 2000 sheets x 1 -tray High Capacity Feeder C1-DS: 2000 sheets x 2 -tray	
	Max	7260 sheets [Standard + High Capacity Feeder C1-DS]	
Output Tray Capacity <sup>5</sup>	500 sheets (A3)		
Power Supply	AC220-240 V +/- 10 %, 10 A, 50/60 Hz common		
Maximum Power Consumption <sup>6</sup>	2.4 kW		
Dimensions <sup>7</sup>	W 1022 x D 804 x H 1392 mm		
Weight <sup>8</sup>	232 kg		

\*1: When continuously printing a single document. 60 to 128 gsm, uncoated paper. Print speed may be reduced depending on conditions of output data, on whether auto image quality adjustment is performed, on whether the job includes a mixture of paper sizes and types, and other reasons.  
 \*2: Image loss width: Lead edge 4.0 mm, Trail edge 4.0 mm, Front 3.5 mm, Rear 3.5 mm.  
 \*3: Banner Printing 60 to 220 gsm. \*4: 80 gsm paper. \*5: Offset Catch Tray. \*6: Main unit with Offset Catch Tray.  
 \*7: Includes main unit and Large Size UI panel. Excludes output tray and print server. With the Bypass Tray closed.  
 \*8: Includes main unit, photoreceptor, and Large Size UI panel. Excludes output tray, print server, paper, and toner.

## Scan Function

Item	Description
Scan Resolution	600 x 600 dpi, 400 x 400 dpi, 300 x 300 dpi, 200 x 200 dpi
Scan Speed	Same as the "Scan Speed" for the Duplex Automatic Document Feeder
Scanning Method	Store to folder (TWAIN Interface support), Scan to PC (FTP, SMB), Scan to e-mail

## Copy Function

Item	Description	
Scan Resolution	600 x 600 dpi	
Printing Resolution	2400 x 2400 dpi (High Resolution Photo) 600 x 600 dpi (Text / Text-Photo / Photo / Map)	
First Copy Output Time	B/W	4.1 seconds or less (A4 / Monochrome priority mode)
	Colour	6.5 seconds or less (A4 / Colour priority mode)

## Print Server [GX-i Print Server for the PrimeLink C9070 / C9065 Printer]

Item	Description
Type	Main unit built-in type
CPU	Intel® Core™ i3-7101E Processor (3.9 GHz)
Storage device	Hard disk: 1 TB
Memory capacity	16 GB (Max: 16 GB)
Server Operation System	Windows 10 IoT Enterprise (64bit)
Page Description Language	Adobe® PostScript® 3™, PDF/VT-1, PDF/VT-2, PPML, VIPP <sup>1</sup>
Print Data Format	PS, PDF1.7, PDF/X-1a, PDF/X-3, PDF/X-4, PDF/X-5, EPS, TIFF, JPEG
Supported Operating System	Windows 10 (32bit), Windows 10 (64bit), Windows 8.1 (32bit) Windows 8.1 (64bit), Windows 7 (32bit) [Service Pack 1] Windows 7 (64bit) [Service Pack 1] Windows Server 2019 (64bit), Windows Server 2016 (64bit) Windows Server 2012 R2 (64bit), Windows Server 2012 (64bit) Windows Server 2008 R2 (64bit) [Service Pack 1] Windows Server 2008 (32bit) [Service Pack 2] Windows Server 2008 (64bit) [Service Pack 2] macOS 10.14 Mojave, macOS 10.13 High Sierra macOS 10.12 Sierra, OS X 10.11 El Capitan, OS X 10.10 Yosemite
Interface	Ethernet: 1000BASE-T / 100BASE-TX / 10BASE-T x 2 USB: USB3.0 x 4, USB2.0 x 2
Network Protocol	TCP/IP (lpd/FTP/IPP <sup>2</sup> / SMB/JDF/HTTP), AppleTalk <sup>3</sup> , Bonjour
Power Supply	AC100 - 240 V +/- 10 %, 2.5 A (100 V) / 1.1 A (240 V), 50/60 Hz common
Maximum Power Consumption	0.2 kW
Dimensions	W 290 x D 135 x H 318 mm
Weight	6.5 kg

Model: A-SV10  
 \*1: Used with optional software FreeFlow VI Compose. \*2: Used to work with FreeFlow Digital Workflow Collection.  
 \*3: AppleTalk is not supported by Mac OS X 10.6 Snow Leopard or later.

## Duplex Automatic Document Feeder C1-PC

Item	Description	
Original Size / Paper Weight Capacity <sup>2</sup>	Max A3, Min A6 <sup>1</sup> 38 to 200 gsm (In Duplex: 50 to 200 gsm) 250 sheets	
Scan Speed <sup>3</sup>	Copy	B/W: 80 sheets/minute Colour: 75 sheets/minute
	Scan	B/W: 135 sheets/minute, Colour: 135 sheets/minute (1 pass, 2 sided scanning: B/W: 270 ppm, Colour: 270 ppm) [Fuji Xerox Standard Paper (A4), 200 dpi, to Folder.]

\*1: The minimum custom size is 84 x 140 mm. \*2: 64 gsm paper.  
 \*3: The scanning speed varies depending on the documents.

## HCF B1 (Optional)

Item	Description
Paper Size	Standard Size: Max A4, Min JIS B5
Paper Weight	60 to 220 gsm
Feeding Capacity / Number of Tray <sup>1</sup>	2000 sheets x 1 -tray
Dimensions	W 389 x D 610 x H 377 mm
Weight	29 kg

\*1: 80 gsm paper.

## High Capacity Feeder B1-S (Optional)

Item	Description
Paper Size <sup>1</sup>	Standard Size: Max A3, Min A6 Custom Size: 100 x 148 mm to 330 x 660 mm <sup>2</sup>
Paper Weight	60 to 350 gsm <sup>3</sup>
Feeding Capacity / Number of Tray <sup>4</sup>	2000 sheets x 1 -tray
Power Supply	AC100-120 V +/- 10 %, 2.5 A / AC220-240 V +/- 10 %, 1.5 A, 50/60 Hz common
Maximum Power Consumption	360 W
Dimensions	W 988 x D 762 x H 992 mm
Weight <sup>5</sup>	160 kg

Note: When High Capacity Feeder B1-S is connected, Bypass Tray is detached from the printer and attached to this option.  
 \*1: If paper with a lead edge length between 100 mm and 182 mm is used, Post Card Kit is required.  
 \*2: When Bypass Tray is connected. When Bypass Tray is not connected, Max 330 to 488 mm.  
 \*3: Banner Printing 60 to 220 gsm.  
 \*4: 80 gsm paper.  
 \*5: Excludes the Bypass Tray and the Large Size UI panel.

## High Capacity Feeder C1-DS (Optional)

Item	Description
Paper Size <sup>1</sup>	Standard Size: Max A3, Min A6 Custom Size: 100 x 148 mm to 330 x 660 mm <sup>2</sup>
Paper Weight	60 to 350 gsm <sup>3</sup>
Feeding Capacity / Number of Tray <sup>4</sup>	2000 sheets x 2 -tray
Power Supply	AC100-120 V +/- 10 %, 5 A / AC220-240 V +/- 10 %, 3 A, 50/60 Hz common
Maximum Power Consumption	720 W
Dimensions	W 988 x D 762 x H 992 mm
Weight <sup>5</sup>	190 kg

Note: When High Capacity Feeder C1-DS is connected, Bypass Tray is detached from the printer and attached to this option.  
 \*1: If paper with a lead edge length between 100 mm and 182 mm is used, Post Card Kit is required.  
 \*2: When Bypass Tray is connected. When Bypass Tray is not connected, Max 330 to 488 mm.  
 \*3: Banner Printing 60 to 220 gsm.  
 \*4: 80 gsm paper.  
 \*5: Excludes the Bypass Tray and the Large Size UI panel.

## Simple Catch Tray / Offset Catch Tray (Optional)

Item	Description	
	Simple Catch Tray	Offset Catch Tray
Paper Size	Standard Size: Max A3, Min A6 Custom Size: 100 x 148 mm to 330 x 660 mm	
Paper Weight	60 to 350 gsm <sup>1</sup>	
Paper Capacity <sup>2</sup>	500 sheets	

\*1: Banner Printing 60 to 220 gsm.  
 \*2: 64 gsm paper.

## Interface Decurler Module D1 (Optional)

Item	Description
Power Supply	AC100-240 V +/- 10 %, 1.3 A (100 V) / 0.5 A (240 V), 50/60 Hz common When Inserter D1 is installed: AC100-240 V +/- 10 %, 2 A (100 V) / 0.9 A (240 V), 50/60 Hz common
Maximum Power Consumption	250 W
Dimensions	W 340 x D 725 x H 992 mm
Weight	40 kg

Note: Interface Decurler Module D1 is necessary for connecting the Finisher D6, Finisher D6 Plus or Finisher D6 with Booklet Maker to the printer.

## Inserter D1 (Optional)

Item	Description
Paper Size	Standard Size: Max A3, Min A5 Custom Size: 182 x 148 mm to 330 x 488 mm
Paper Weight	60 to 350 gsm
Paper Capacity <sup>1</sup>	250 sheets
Power Supply	Supplied from the Interface Decurler Module D1
Dimensions <sup>2</sup>	W 700 x D 725 x H 1235 mm
Weight	45 kg

Note: Finisher D6, Finisher D6 Plus or Finisher D6 with Booklet Maker is required.  
 Cannot print on the paper loaded in Inserter D1.  
 \*1: 82 gsm paper.  
 \*2: The width of the paper transfer area when connected to the device is 165 mm.

### C3 Finisher / C3 Finisher with Booklet Maker (Optional)

Item		Description	
		C3 Finisher	C3 Finisher with Booklet Maker
Type	Output Tray	Sort / Stack	
	Finishing Tray	Sort (Offset available) / Stack (Offset available)	
	Booklet Tray	-	Sort / Stack
Paper Size	Output Tray	Standard Size : Max A3, Min A6 Custom Size: 100 x 148 mm to 330 x 660 mm	
	Finishing Tray	Standard Size : Max A3, Min JIS B5 Custom Size: 203 x 182 mm to 330 x 488 mm	
Paper Weight	Output Tray	60 to 350 gsm <sup>1</sup>	
	Finishing Tray	60 to 350 gsm	
Paper Capacity <sup>2</sup>	Output Tray	500 sheets (A4)	
	Finishing Tray	[Without Stapling] A4: 3000 sheets JIS B4 or larger: 1500 sheets Mixed Size Stacking <sup>3</sup> : 300 sheets [With Stapling] A4: 200 sets (Single stapling), 100 sets (Dual stapling) or 3000 sheets JIS B4 or larger: 100 sets or 1500 sheets Mixed Size Stacking <sup>3</sup> : 70 sets or 200 sheets	[Without Stapling] A4: 1500 sheets JIS B4 or larger: 1500 sheets Mixed Size Stacking <sup>3</sup> : 300 sheets [With Stapling] A4: 200 sets (Single stapling), 100 sets (Dual stapling) or 1500 sheets JIS B4 or larger: 100 sets or 1500 sheets Mixed Size Stacking <sup>3</sup> : 70 sets or 200 sheets
		Booklet Tray	-
	Capacity	50 sheets (90 gsm or less)	
Staple	Paper Size	Standard Size : Max A3, Min JIS B5 Custom Size : 203 x 182 mm to 297 x 432 mm	
	Paper Weight	60 to 220 gsm	
	Position	Single stapling, Dual stapling	
Punch <sup>5</sup>	Number of Holes <sup>6</sup>	2-hole / 4-hole punch or 2-hole / 3-hole punch (US Specifications)	
	Paper Size	Max A3 Min JIS B5 (2-hole punch, 3-hole punch), A4 (4-hole punch)	
	Paper Weight	60 to 200 gsm	
Booklet Finishing	Capacity <sup>7</sup>	-	Saddle Staple: 16 sheets Single Fold: 5 sheets
	Paper Size	-	Standard Size: Max A3, Min JIS B5 Custom Size: 210 x 279 mm to 330 x 457 mm
	Paper Weight	-	60 to 220 gsm
Dimensions	W 834 x D 589 x H 1056 mm When Folder Unit CD1 is installed: W 1075 x D 726 x H 1056 mm	W 894 x D 589 x H 1056 mm When Folder Unit CD1 is installed: W 1135 x D 726 x H 1056 mm	
Weight	48 kg When Folder Unit CD1 is installed: 100 kg	65 kg When Folder Unit CD1 is installed: 117 kg	

Note: Transport Unit V1 is required.

\*1: Banner Printing 60 to 220 gsm. \*2: 80 gsm paper. \*3: When larger size sheets are stacked on top of smaller size sheets.  
\*4: For 16 sheets/set booklet. Paper may not be accepted depending on paper type and other usage conditions.  
\*5: Optional. \*6: The possible number of holes depends on the paper size.  
\*7: The capacity can decrease depending on type and weight of paper being used and other conditions.

### Folder Unit

Item		Description	
		Folder Unit CD1	Folder Unit CD2
Z Fold Half Sheet	Paper Size	A3, JIS B4	
	Paper Weight	60 to 90 gsm	
Tri-fold	Paper Size	A4	
	Paper Weight	60 to 90 gsm	
	Paper Capacity <sup>1</sup>	30 sheets	
Power Supply	AC100-127 V +/- 10 %, 1 A / AC200-240 V +/- 10 %, 0.6 A, 50/60 Hz common		
Maximum Power Consumption	100 W		
Dimensions	W 235 x D 726 x H 992 mm		
Weight	53 kg	55 kg	

Note: Folder Unit CD1 is option for C3 Finisher and C3 Finisher with Booklet Maker.

Folder Unit CD2 is option for Finisher D6, Finisher D6 Plus and Finisher D6 with Booklet Maker.

\*1: 82 gsm paper.

### Crease/Two-sided Trimmer D2 (Optional)

Item		Description	
Two-sided Trim	Paper Size	Standard Size: Max A3, Min A4 Custom Size: 194 x 210 mm to 330 x 488 mm	
	Paper Weight	60 to 350 gsm	
	Trim dimensions	One side 6 to 25 mm	
Crease	Paper Size	Standard Size: Max A3, Min JIS B5 Custom Size: 182 x 210 mm to 330 x 488 mm	
	Paper Weight	60 to 350 gsm <sup>1</sup>	
	Number of lines	1 to 5	
Power Supply	AC100-240 V +/- 10 %, 4 A (100 V) / 2 A (240 V), 50/60 Hz common		
Maximum Power Consumption	480 W		
Dimensions	W 605 x D 725 x H 992 mm		
Weight	128 kg		

Note: Finisher D6, Finisher D6 Plus or Finisher D6 with Booklet Maker is required.

\*1: Up to 300 gsm is supported for booklet finishing, 157 gsm or more is supported for single sheet.

### Finisher D6 / Finisher D6 Plus (Coming soon) / Finisher D6 with Booklet Maker (Optional)

Item		Description		
		Finisher D6	Finisher D6 Plus	Finisher D6 with Booklet Maker
Type	Output Tray	Sort / Stack		
	Finishing Tray	Sort (Offset available) / Stack (Offset available)		
	Booklet Tray	-	-	Sort / Stack
Paper Size	Output Tray	Standard Size: Max A3, Min A6 Custom Size: 100 x 148 mm to 330 x 660 mm		
	Finishing Tray	Standard Size: Max A3, Min A5 Custom Size: 148 x 148 mm to 330 x 488 mm		
Paper Weight	Output Tray	60 to 350 gsm <sup>1</sup>		
	Finishing Tray	60 to 350 gsm		
Paper Capacity <sup>2</sup>	Output Tray	500 sheets (A4)		
	Finishing Tray	[Without Stapling] A4: 3000 sheets JIS B4 or larger: 1500 sheets Mixed Size Stacking <sup>3</sup> : 350 sheets [With Stapling] A4: 200 sets (Single stapling), 100 sets (Dual stapling) or 3000 sheets JIS B4 or larger: 100 sets or 1500 sheets Mixed Size Stacking <sup>3</sup> : 70 sets or 200 sheets	[Without Stapling] A4: 2000 sheets JIS B4 or larger: 1500 sheets Mixed Size Stacking <sup>3</sup> : 350 sheets [With Stapling] A4: 200 sets or 2000 sheets JIS B4 or larger: 100 sets or 1500 sheets	
		Booklet Tray	-	20 sets <sup>4</sup>
	Capacity	100 sheets <sup>5</sup> (90 gsm or less)		
Staple	Paper Size	Standard Size: Max A3, Min A5 Custom Size: 182 x 148 mm to 297 x 432 mm		
	Paper Weight	60 to 350 gsm		
	Position	Single stapling <sup>6</sup> , Dual stapling		
Punch <sup>7</sup>	Number of Holes <sup>8</sup>	2-hole / 4-hole punch or 2-hole / 3-hole punch (US Specifications)		
	Paper Size	Standard Size: Max A3, Min JIS B5 (2-hole punch, 3-hole punch), A4 (4-hole punch) Custom Size: 203 x 182 mm to 297 x 431 mm		
	Paper Weight	60 to 220 gsm		
Booklet Finishing	Capacity <sup>9</sup>	-	-	Saddle Staple: 30 sheets Single Fold: 5 sheets
	Paper Size	-	-	Standard Size: Max A3, Min JIS B5 Custom Size: 182 x 257 mm to 330 x 488 mm
	Paper Weight	-	-	60 to 300 gsm
Power Supply	AC100-127 V +/- 10 %, 3 A / AC200-240 V +/- 10 %, 1.8 A, 50/60 Hz common			
Maximum Power Consumption	300 W			
Dimensions	W 855 x D 725 x H 1200 mm When Folder Unit CD2 is installed: W 1092 x D 726 x H 1200 mm	W 892 x D 725 x H 1200 mm When Folder Unit CD2 is installed: W 1134 x D 726 x H 1200 mm		
Weight	85 kg When Folder Unit CD2 is installed: 140 kg	90 kg When Folder Unit CD2 is installed: 145 kg	105 kg When Folder Unit CD2 is installed: 160 kg	

Note: Interface Decurler Module D1 is required.

\*1: Banner Printing 60 to 220 gsm. \*2: 82 gsm paper. \*3: When larger size sheets are stacked on top of smaller size sheets.

\*4: When over 17 sheets/set, the booklet tray capacity is 16 sets. \*5: 65 sheets for sizes exceeding A4.

\*6: One place rear angled stapling is supported on A4 and A3 only. \*7: Optional.

\*8: The possible number of holes depends on the paper size.

\*9: The capacity can decrease depending on type and weight of paper being used and other conditions.

### SquareFold Trimmer D1 (Optional)

Item		Description
Paper Size	Same as the paper size of the Finisher D6 Booklet Finishing.	
Paper Weight	Same as the paper weight of the Finisher D6 Booklet Finishing.	
Booklet Tray Capacity <sup>1</sup>	20 sets (15 sheets bind and below), 15 sets (16 sheets bind and above)	
Face Trim	Capacity <sup>2</sup>	Saddle Staple: 30 sheets, Single Fold: 5 sheets
	Trim dimensions	2 to 20 mm
Square Fold Capacity <sup>2,3</sup>	30 sheets	
Power Supply	AC100-240 V +/- 10 %, 0.8 A (100 V) / 0.4 A (240 V), 50/60 Hz common	
Maximum Power Consumption	96 W	
Dimensions	W 1066 x D 725 x H 552 mm	
Weight	100 kg	

Note: Finisher D6 with Booklet Maker is required.

\*1: Paper may not be accepted depending on paper type and other usage conditions.

\*2: The capacity can decrease depending on type and weight of paper being used and other conditions.

\*3: Square folding is not supported for single-folding and saddle stapling of less than 5 sheets.

### Finishing Transport (Optional) (Coming soon)

Item		Description
Power Supply	AC100-240 V +/- 10 %, 5 A (100 V) / 2 A (240 V), 50/60 Hz common	
Maximum Power Consumption	500 W	
Dimensions	W 593 x D 652 x H 1004 mm	
Weight	65 kg	

Note: Finishing Transport and Finisher D6 Plus are required for connecting a third party vendor finisher to the printer.

# Remote Services\*

Fuji Xerox Remote Services increases machine reliability, uptime and productivity — making it easier for us to help you make your business stronger. Our Remote Services seamlessly integrates support systems and tools with highly skilled support teams across the globe. These connections enable us to provide proactive and relevant problem resolutions through robust underlying knowledge and comprehensive product understanding.



\* Subject to availability.

## Benefits:

- Transmit machine data to provide preventive maintenance, predict machine wear and reduce the time to fix issues.
- Monitor supplies and consumable levels (such as toner) and automatically deliver them, saving time and ensuring you have what you need to keep printing, when you need it.
- Automatically report billing meters to save time and improve accuracy.

## Notes

- 1) To comply with paper weight specifications, it is recommended to use Fuji Xerox recommended paper. Document may not be printed correctly depending on usage conditions.
- 2) Functional spare parts will be available for at least 7 years after the product is no longer manufactured.

All product names and company names mentioned in this brochure are trademarks or registered trademarks of their respective companies. The product specifications, appearance and other details in this brochure are subject to change without notice for improvements.

**Reproduction Prohibitions** Please note that reproduction of the following is prohibited by law : Domestic and foreign currencies, government-issued securities, and national bonds and local bond certificates. Unused postage stamps, post cards, etc. Certificate stamps stipulated by law. Reproducing works forming the subject matter of copyright (literary works, musical works, paintings, engravings, maps, cinematographic works, drawings, photographic works, etc.) is not permitted unless the reproduction is for the purpose of personal use, family use or other similar uses within a limited circle.



## For Your Safety

Before using the product, read the Instruction Manual carefully for proper use. Use the product with the power source and voltage specified. Be sure to establish ground connection. Otherwise, electronic shock may result in the case of a failure or short circuit.

For more information or detailed product specification, please call or visit us at

## Fuji Xerox Australia

8 Khartoum Road, Macquarie Park New South Wales 2113

Tel. 1800 028 962

[www.fujixerox.com.au](http://www.fujixerox.com.au)

