

September 2020

PRX Series Pilots for Pilot-Operated Pressure Reducing Regulators

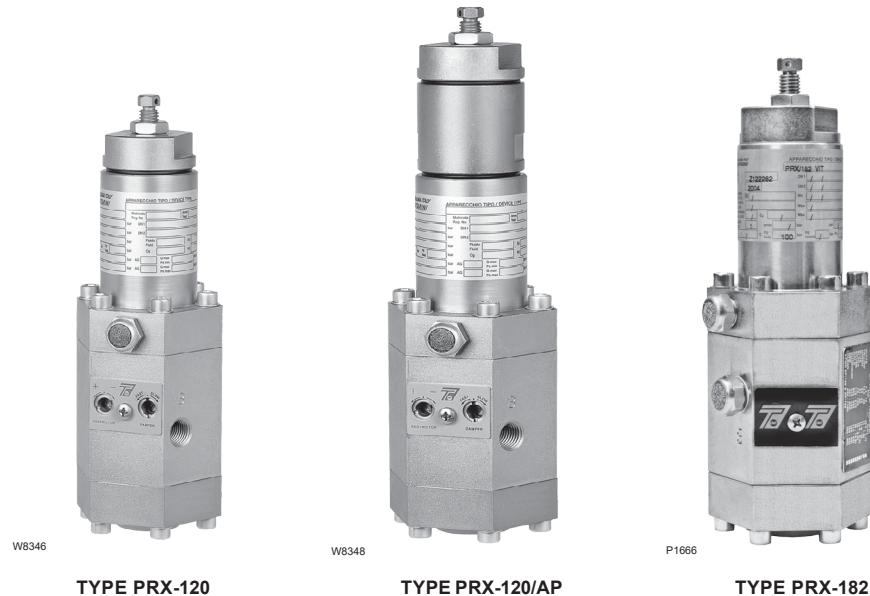

Figure 1. PRX Series Pressure Reducing Pilots

Introduction

Scope of the Manual

This manual provides installation, startup, maintenance and parts ordering information for the PRX Series pilots and Type SA/2 filter used together with Pilot-Operated Pressure Reducing Regulators for high pressure applications.

For information on mounting on Pilot-operated Regulators, monitoring systems and installations, refer to full product literature:

Type EZH: D103077X012

Type EZR: D102600X012

Type FL: D103068X012

Product Description

The PRX Series pilots are mainly used in natural gas, air or other non-corrosive gas applications. They have a double diaphragm which provides increased accuracy and sensitivity,

an integral damper screw to adjust opening and closing speeds and a restrictor screw to adjust pilot gain.

The PRX Series pilots can be also be used in other applications such as relief valve or backpressure regulators and as a quick dump pilot.

Furthermore, PRX Series pilots have the ability to handle a wide range of setpoints, from 14.5 to 1160 psig / 1.00 to 80.0 bar.

Type SA/2 Pilot Supply Filter Regulator

The PRX Series pilots are usually used together with the Type SA/2 pilot supply filter regulator. The Type SA/2 provides a constant supply pressure to the PRX Series pilot that is approximately 45 psi / 3.1 bar over set pressure. The Type SA/2 has an integral 5 micron filter.

PRX Series

Specifications

The Specifications section lists pressure limitations and other specifications for all models of PRX Series pilots. Please note that the pilot control spring range is displayed on the pilot nameplate.

<p>Maximum Inlet Pressures⁽¹⁾ See Table 2</p> <p>Outlet (Control) Pressure Ranges See Table 1</p> <p>Accuracy Class See Table 1</p> <p>Process Temperature Capabilities⁽¹⁾ -4 to 140°F / -20 to 60°C</p> <p>Pilot and Filter Regulator Flow Coefficients Type PRX Pilot: C_g: 10.5; C_v: 0.36; C_f: 29 Type SA/2 Filter Regulator: C_g: 4.9</p>	<p>Threaded Connections 1/4 NPT</p> <p>Orifice Size 0.12 in. / 3.0 mm</p> <p>Type SA/2 Allowable Pressure⁽¹⁾ 1450 / 100 bar</p> <p>Options Type 252 Pilot Supply filter</p>
--	--

1. The pressure/temperature limits in this Instructional Manual and any applicable standard or code limitation should not be exceeded.

Table 1. Outlet (Control) Pressure Ranges, Accuracy Class and Pilot Spring Information

TYPE	OUTLET (CONTROL) PRESSURE RANGE		PILOT CONTROL SPRING INFORMATION									
			Part Number	Color Code	Wire Diameter		Free Length		Maximum Operating Pressure		Maximum Emergency Pressure	
	psig	bar			In.	mm	In.	mm	psig	bar	psig	bar
PRX/120 PRX/125	14.5 to 26	1.00 to 1.8	M0255240X12	Yellow	0.110	2.79	2.16	55.0	----	----		
	23 to 44	1.6 to 3.0	M0255230X12	Green	0.126	3.20	2.16	55.0				
	41 to 80	2.8 to 5.5	M0255180X12	Blue	0.138	3.55	2.16	55.0				
	73 to 123	5.0 to 8.5	M0255220X12	Black	0.157	3.99	2.16	55.0				
PRX/120-AP PRX/125-AP	116 to 210	8.0 to 14.5	M0255210X12	Silver	0.177	4.50	2.16	55.0	----	----		
	203 to 334	14.0 to 23.0	M0255200X12	Gold	0.197	5.00	2.01	51.0				
	319 to 435	22.0 to 30.0	M0255860X12	Aluminum	0.236	5.99	2.01	51.0				
PRX/120-AP PRX/125-AP	435 to 1160	30.0 to 80.0	M0273790X12	Clear	0.335	8.51	3.94	100	----	----		
PRX/131	14.5 to 26	1.0 to 1.8	M0255240X12	Yellow	0.110	2.79	2.16	55.0	435	30.0	1480	102
	23 to 44	1.6 to 3.0	M0255230X12	Green	0.126	3.20	2.16	55.0				
	41 to 80	2.8 to 5.5	M0255180X12	Blue	0.138	3.55	2.16	55.0				
	73 to 123	5.0 to 8.5	M0255220X12	Black	0.157	3.99	2.16	55.0				
	116 to 210	8.0 to 14.5	M0255210X12	Silver	0.177	4.50	2.16	55.0				
	203 to 334	14.0 to 23.0	M0255200X12	Gold	0.197	5.00	2.01	51.0				
319 to 435	22.0 to 30.0	M0255860X12	Aluminum	0.236	5.99	2.01	51.0					
PRX-AP/131	435 to 1160	30.0 to 80.0	M0273790X12	Clear	0.335	8.51	3.94	100	1160	80.0		
PRX/182	29 to 116	2.0 to 8.0	M0255220X12	Black	0.157	3.99	2.16	55.0	609	42.0		
	73 to 290	5.0 to 20.0	M0255200X12	Gold	0.197	5.00	2.01	51.0				
	217 to 609	15.0 to 42.0	M0255190X12	Red	0.236	5.99	2.01	51.0				
PRX-AP/182	435 to 1160	30.0 to 80.0	M0273790X12	Clear	0.335	8.51	3.94	100	1160	80.0		

1. Accuracy includes outlet pressure drop plus hysteresis (friction), but does not include lockup.

2. Restrictor screw is one turn counterclockwise from fully seated.

Table 2. PRX Series Pilot Pressure Ratings

MAXIMUM INLET PRESSURE		MAXIMUM EMERGENCY OUTLET PRESSURE OR MAXIMUM EMERGENCYSENSEPRESSURE ⁽¹⁾		MAXIMUM BLEED (EXHAUST) PRESSURE FOR MONITOR PILOTS		MAXIMUM PILOT SPRING CASE PRESSURE FOR PRESSURE LOADING	
psig	bar	psig	bar	psig	bar	psig	bar
1480	102	1480	102	1480	102	1160	80

1. Maximum pressure to prevent the casings from bursting during abnormal operation (leaking to atmosphere and internal parts damage may occur).

Available Configurations

Type PRX/120: Outlet pressure range of 14.5 to 435 psig / 1.00 to 30.0 bar. The Type PRX/120 can be used as the pilot on single stage pressure reducing regulators, as the monitor or working pilot in wide-open monitor systems or as the working pilots in working monitor systems.

Type PRX/120-AP: Outlet pressure range of 435 to 1160 psig / 30.0 to 80.0 bar. The Type PRX/120-AP can be used as the pilot on single stage pressure reducing regulators, as the monitor or working pilot in wide-open monitor systems or as the working pilots in working monitor systems.

Type PRX/125: Identical to the Type PRX/120 except the restriction screw is removed. The Type PRX/125 can only be used as the monitor override pilot on working monitor applications.

Type PRX/125-AP: Identical to the Type PRX/120-AP except the restriction screw is removed. The Type PRX/125-AP can only be used as the monitor override pilot on working monitor applications.

Type PRX/131: Outlet pressure range of 14.5 to 435 psig / 1.00 to 30.0 bar. Type PRX/131 is used as a booster or quick dump pilot with another PRX Series pilot on a single stage pressure reducing regulator or with the monitor pilot on the monitor regulator in wide-open monitor systems.

Type PRX-AP/131: Outlet pressure range of 435 to 1160 psig / 30.0 to 80.0 bar. This pilot is used as a booster or quick dump pilot with another PRX Series pilot on a single stage pressure reducing regulator or with a monitor pilot on the monitor regulator in wide-open monitor systems.

Type PRX/182: Outlet pressure range of 29 to 609 psig / 2.0 to 42.0 bar. This pilot is used in relief valve or backpressure regulator situations.

Type PRX-AP/182: Outlet pressure range of 435 to 1160 psig / 30.0 to 80.0 bar. This pilot is used in relief valve or backpressure regulator situations.

Principle of Operation

Types PRX/120 and PRX/125

Pilot-operated regulators use inlet pressure as the operating medium, which is reduced through pilot operation to load the actuator diaphragm. Outlet or downstream pressure opposes loading pressure in the actuator and also opposes the pilot control spring.

When outlet pressure drops below the setting of the pilot control spring, pilot control spring force on the pilot diaphragm thus opens the pilot valve plug, providing additional loading pressure to the actuator diaphragm. This diaphragm loading pressure opens the main valve plug, supplying the required flow to the downstream system. Any excess loading pressure on the actuator diaphragm escapes downstream through the bleed restriction in the pilot.

When the gas demand in the downstream system has been satisfied, the outlet pressure increases. The increased pressure is transmitted through the downstream control line and acts on the pilot diaphragm. This pressure exceeds the pilot spring setting and moves the diaphragm, closing the orifice. The loading pressure acting on the main diaphragm bleeds to the downstream system through a bleed restriction in the pilot.

Type PRX/131 Pilot

The Type PRX/131 pilot is often referred to as a quick dump pilot or a booster pilot, as it helps to boost the pressure release. This pilot is used with another PRX Series pilot on a single stage pressure reducing regulator or with the monitor pilot when two regulators are set up in a Working Monitor or Wide-Open Monitor system. The Type PRX/131 is always attached to the Monitor regulator and allows the regulator to operate faster. If the downstream pressure (P_2) increases, the Type PRX/131 opens and the loading pressure to the regulator drops, allowing the regulator to release pressure off the downstream side of the diaphragm so it closes faster.

Type PRX/182 Pilot

The Type PRX/182 pilot is used in relief valve or backpressure regulator configurations. The pilot bleeds constantly while the relief valve is in operation. The pilot does not bleed when inlet pressure is below set pressure. The pilot exhaust can be connected directly to the main valve exhaust pipe if the pilot connection and the exhaust pipe are designed to prevent significant backpressure buildup during full flow conditions.

Adjustment

The adjustment of the regulator is performed by means of the pilot adjusting screw, which varies the compression of the control spring. Adjustment is performed while the regulator is in operation with the aid of a pressure gauge to monitor downstream pressure; loosen the locknut and turn the adjusting screw slowly to adjust outlet pressure.

Installation



Personal injury or equipment damage, due to bursting of pressure-containing parts may result if this regulator is overpressured or is installed where service conditions could exceed the limits given in the Specification section and on the appropriate nameplate or where conditions exceed any rating of the adjacent piping or piping connections. To avoid such injury or damage, provide pressure-relieving or pressure-limiting devices to prevent

service conditions from exceeding those limits. Also, be sure the installation is in compliance with all applicable codes and regulations.

Additionally, physical damage to the regulator could break the pilot off the main valve, causing personal injury and property damage due to bursting of pressure-containing parts. To avoid such injury and damage, install the regulator in a safe location.

1. Use qualified personnel when installing, operating and maintaining pilots. Before installing, inspect pilot and tubing, for any shipment damage or foreign material that may have collected during crating and shipment. Make certain that body is clean and the pipelines are free of foreign material.

WARNING

In hazardous or flammable gas service, vented gas may accumulate and cause personal injury, death or property damage due to fire or explosion.

Vent a regulator in hazardous gas service to a remote, safe location away from air intakes or any hazardous location. The vent line or stack opening must be protected against condensation or clogging.

2. PRX Series pilots have a 1/4 NPT vent connection in the spring case. To remotely vent gas from the spring case, remove the screened vent and connect 1/4 in. / 6.4 mm piping or tubing to the spring case connection. The piping or tubing should vent to a safe location, have as few elbows as possible and have a screened vent on its exhaust. Install the regulator and any remote vent piping or tubing so that the vent is protected from condensation, freezing or substances that may clog it.

CAUTION

To avoid freeze up because of pressure drop and moisture in the gas, use anti-freeze practices, such as heating the supply gas or adding a de-icing agent to the supply gas.

3. The PRX Series pilot connections are 1/4 NPT. Connect a downstream control (sense) line to a straight run of pipe 6 to 10 pipe diameters from the regulator outlet, using 3/8 in. / 9.5 mm or larger outside diameter tubing. If such a distance is not practical, connect the control line away from elbows, swages, nipples or any area where abnormal flow velocities occur. Connect the other end of the control line to the "A" port on the bottom of the PRX Series pilot.
4. Connect a downstream bleed line from the "S" port on the PRX Series pilot to a straight run of pipe 6 to 10 pipe diameters from the regulator outlet, using 3/8 in. / 9.5 mm or larger outside diameter tubing.

CAUTION

To prevent damage to the pilot during startup, the sense and bleed lines should be located on the same side of the downstream block valve.

5. Install hand valves in the downstream sense and bleed lines if desired. If hand valves are installed, they should be full flow valves, such as a full port ball valve.
6. For optional remote pneumatic loading of a PRX Series pilot, make the spring case piping connections just as they would be made for remote venting.

Startup and Adjustment for Types PRX/120 and PRX/125

Prestartup Considerations

Each regulator is factory-set for the outlet pressure specified on the order. If no setting was specified, outlet pressure was factory-set at the mid-range of the pilot control spring. Before beginning the startup procedure in this section, make sure the following conditions are in effect:

- Block valves isolate the regulator
- Vent valves are closed
- A bypass, if any, is in operation

In all cases, check the control spring setting to make sure it is correct for the application.

CAUTION

Be sure to slowly introduce pressure into the system to prevent downstream overpressure due to potential rapid pressure increase. Pressure gauges should always be used to monitor downstream pressure during startup. Procedures used in putting this regulator into operation must be planned accordingly if the downstream system is pressurized by another regulator or by a manual bypass.

Note

When using a Type SA/2 pilot supply filter regulator, the differential pressure across the regulator must be at least 45 psid / 3.1 bar d for optimum regulator performance. The Type SA/2 can be removed if differential pressure across the regulator is less than 45 psid / 3.1 bar d and inlet pressure stays at or below 200 psig / 13.8 bar.

Table 3. Torque Recommendation and Request Tools

SERIES	CAP SCREW (KEY 10)		OPEN END WRENCH	ALLEN WRENCH
	Ft-Lbs	N•m	mm	mm
PRX	7.5 to 9.2	10.2 to 12.4	10, 17	5

Pilot Adjustment for Types PRX/120 and PRX/125

Loosen locknut (key 2) and turn the adjusting screw into the spring case to increase (or out of the spring case to decrease) the downstream pressure. When the desired setpoint adjustment is completed and verified, tighten the locknut to lock the adjusting screw in position.

PRX Series Pilot Restrictor and Damper Screw Adjustment

Note

The Type PRX/125 (upstream monitor pilot in working monitor installations) does not have a restrictor screw.

The Restrictor and Damper screws on the PRX Series pilot control the regulator's proportional band (droop) and speed of response.

1. Start with the restrictor screw 1 turn counterclockwise from fully seated (turn restrictor fully clockwise then 1 turn counterclockwise) and the damper screw fully counterclockwise.
2. Turn damper screw clockwise until desired performance is achieved. This reduces the flow path of the damper. If the damper becomes fully seated (no longer able to turn clockwise) and the desired performance has not been achieved, return the damper screw to the fully counterclockwise position.

WARNING

The damper screw should not be left in the fully seated position, as it will lock the regulator in last position which could cause incorrect pressure regulation.

3. Turn the restrictor screw an additional turn counterclockwise from fully seated. This increases the flow path of the restrictor. If additional tuning is required, repeat step 2. Follow this method until desired performance is achieved.

Shutdown

CAUTION

If the pilot bleed control line pressure is shutdown first, the downstream system may be subjected to full inlet pressure.

1. If the pilot setting must be disturbed, be sure to keep some tension on the spring. This will prevent trapping inlet pressure during blow down.
2. Slowly close the valves in the following order:
 - a. Inlet block valve
 - b. Outlet block valve
 - c. Control line valve(s), if used.
3. Open the vent valves to depressurize the system.

Maintenance for Types PRX/120 and PRX/125

Pilot parts are subject to normal wear and must be inspected and replaced as necessary. The frequency of inspection and replacement of parts depends upon the severity of service conditions or the requirements of local, state and federal regulations. Due to the care Emerson™ takes in meeting all manufacturing requirements (heat treating, dimensional tolerances, etc.), use only replacement parts manufactured or furnished by Emerson.

All O-rings, gaskets and seals should be lubricated with a good grade of general-purpose grease and installed gently rather than forced into position. Also, apply an anti-seize compound to the adjusting screw threads and other areas as needed. Be certain that the nameplates are updated to accurately indicate any field changes in equipment, materials, service conditions or pressure settings.

WARNING

To avoid personal injury resulting from sudden release of pressure, isolate the pilot from all pressure and cautiously release trapped pressure from the pilot before attempting disassembly.

CAUTION

Always remove spring (key 7) tension before performing maintenance on this unit. To remove spring tension, loosen locknut (key 2) and back out adjusting screw (key 1) until compression is removed from the spring.

Lower Case Maintenance

1. Disconnect pilot and remove from the line.
2. Remove machine screws (key 10) and washers (key 11) from lower cover (key 21) and the separate lower cover from the body (key 16).

3. Use a wrench to hold the stem (key 23) and break loose the stem nut (key 20). Remove the stem nut and washer (key 11).
4. Remove the upper diaphragm plate (key 13), diaphragm (key 14), pad holder (key 22) and O-ring (key 18). Inspect parts for damage or wear, replace if necessary.
5. Remove orifice (key 19) and O-ring (key 17). Inspect the parts for damage or wear and replace if necessary. Lightly lubricate the O-ring and place in the body (key 16). Install the orifice.
6. Set the pad holder (key 22) in the body (key 16).
7. Lightly lubricate the rims of the diaphragm (key 14) and place it on top of the pad holder (key 22). Set the upper diaphragm plate (key 13) on the diaphragm (key 14).
8. Lightly lubricate the O-ring (key 18) and place it in the lower case (key 21).
9. Place the washer key (key 11) and stem nut (key 20) on the stem (key 23) and tighten. *If also performing Upper Case Maintenance, skip to step 2 of the Upper Case Maintenance section.*
10. Insert washers (key 11) and machine screws (key 10) in the lower cover (key 21) and tighten uniformly to ensure proper seal.

Upper Case Maintenance

1. Disconnect pilot and remove it from the line.
2. Loosen locknut (key 2) and back out adjusting screw (key 1) until compression is removed from the spring. Remove cap (key 3).
3. Lift the upper spring seat (key 6), spring (key 7) and O-ring (key 4) out of the upper cover (key 8). Inspect O-ring and replace if necessary.
4. Remove machine screws (key 10) and washers (key 11) from lower cover (key 21) and the separate lower cover from the body (key 16), unless removed during lower diaphragm maintenance. Use a wrench to hold stem (key 23) securely while removing the stem nut (key 26).
5. Remove remaining loose components: washer, upper diaphragm plate, diaphragm, lower diaphragm plate and O-rings (keys 11, 13, 14, 15, 18 and 25). Inspect diaphragm and O-rings for damage or wear and replace if necessary.
6. Lightly lubricate the O-ring (key 25). Place O-ring over the stem (key 23) and press it down into the body (key 16).
7. Set the lower diaphragm plate (key 15) into the body (key 16).
8. Lightly lubricate the rims of the diaphragm (key 14) and place it in the body (key 16) on top of the lower diaphragm plate (key 15).
9. Set the upper diaphragm plate (key 13) on top of the diaphragm (key 14).
10. Place washer (key 11) and stem nut (key 26) on the stem (key 23) and tighten using a wrench to hold the stem.

11. Place the lower spring seat (key 9) on the upper diaphragm nut (key 26) and mount the upper cover (key 8) on top of the body (key 24) and the diaphragm (key 14).
12. Place washers (key 11) and uniformly tighten the machine screws (key 10) to hold the body (key 24) and upper cover (key 8) together. Position the diaphragm convolution facing down and make sure that the diaphragm is not deformed and is properly installed.
13. Install spring (key 7) and upper spring seat (key 6) on top of the lower spring seat (key 9) inside the upper cover (key 8). Install cap (key 3).
14. Screw in adjusting screw (key 1) at desired spring compression and use the lock nut (key 2) to lock the adjusting screw's position. Refer to Pilot Adjustment section (pages 5 and 6) to adjust pilot settings.

Damper and Restrictor Maintenance

1. Remove screw (key 31) and plate (key 29).
2. Remove ring nuts (key 30).
3. Remove damper adjusting screw (key 27). Remove and inspect O-ring (key 28) for damage or wear and replace if necessary. Lightly lubricate O-ring before placing on the adjusting screw. Insert damper adjusting screw into the body (key 16) and tighten. Insert ring nut (key 30) and tighten. Back out damper adjusting screw until it stops.

Note

When using a Type PRX/120 pilot with a Type PRX/125 pilot as a monitor, use the following settings:

- **Restrictor – completely tighten and then back out three full turns.**
 - **Damper – back out until it stops.**
4. Remove restrictor adjusting screw with hole (key 32). Remove and inspect O-ring (key 28) for damage or wear and replace if necessary. Lightly lubricate O-ring before placing on the adjusting screw. Insert restrictor adjusting screw into the body (key 16) and completely tighten. Insert ring nut (key 30) and completely tighten. Back out restrictor adjusting screw 1/2 turn.
 5. Install plate (key 29) and screw (key 31).

The Types PRX/131 and PRX/182 Maintenance (Figure 3)



Always remove spring (key 7) tension before performing maintenance on this unit. To remove spring tension, loosen locknut (key 2) and back out adjusting screw (key 1) until compression is removed from the spring.

Lower Diaphragm Maintenance

1. Disconnect pilot and remove it from the line.
2. Remove machine screws (key 10) from lower cover (key 21) and the separate lower cover from the body (key 16).
3. Use a wrench to hold the stem (key 23) and break loose the stem nut (key 20). Remove the stem nut and washer (key 11).
4. Remove the upper diaphragm plate (key 13), diaphragm (key 14), lower diaphragm plate (key 15) and O-ring (key 18). Inspect parts for damage or wear, replace if necessary.
5. Lightly lubricate the O-ring (key 25). Place O-ring over the stem (key 23) and press it down into the body (key 16).
6. Lightly lubricate the rims of the diaphragm (key 14) and place it on top of the lower diaphragm plate (key 15). Set the upper diaphragm plate (key 13) on the diaphragm (key 14).
7. Lightly lubricate the O-ring (key 18) and place it in the lower cover (key 21).
8. Place the washer (key 11) and stem nut (key 20) on the stem (key 23) and tighten. *If also performing Upper Case Maintenance, skip to step 2 of the Upper Case Maintenance section.*
9. Insert washers (key 11) and machine screws (key 10) in the lower cover (key 21) and tighten uniformly to ensure proper seal.
7. Set the disk holder (key 22) in the body (key 16).
8. Lightly lubricate the rims of the diaphragm (key 14). Position the diaphragm convolution facing down, make sure that the diaphragm is not deformed and is properly installed. Take the diaphragm (key 14) and place it in the body (key 16) on top of the disk holder (key 22).
9. Set the upper diaphragm plate (key 13) on top of the diaphragm (key 14).
10. Place washer (key 11) and stem nut (key 26) on the stem (key 23) and tighten using a wrench to hold the stem.
11. Place the upper spring seat (key 9) on the upper diaphragm nut (key 26) and mount the upper cover (key 8) on top of the body (key 24) and the diaphragm (key 14).
12. Place washers (key 11) and uniformly tighten the machine screws (key 10) to hold the body (key 24) and upper cover (key 8) together.
13. Install spring (key 7) and upper spring seat (key 6) on top of the lower spring seat (key 9) inside the upper cover (key 8). Install cap (key 3).
14. Screw in adjusting screw (key 1) at desired spring compression and use the lock nut (key 2) to lock the adjusting screws position.

Upper Diaphragm Maintenance

1. Disconnect pilot and remove it from the line.
2. Loosen locknut (key 2) and back out adjusting screw (key 1) until compression is removed from the spring. Remove cap (key 3).
3. Lift the upper spring seat (key 6), spring (key 7) and O-ring (key 4) out of the upper cover (key 8). Inspect O-ring and replace if necessary.
4. Remove the machine screws (key 10) and the washers (key 11), separate the upper cover (key 8) from the body (key 16) and lift the lower spring seat (key 9) away from upper diaphragm nut (key 26). Use a wrench to hold stem (key 23) securely while removing the upper diaphragm nut.
5. Remove remaining loose components: washer (key 11), upper diaphragm plate (key 13), diaphragm (key 14), disk holder (key 22) and O-ring (key 18). Inspect diaphragm and O-ring for damage or wear and replace if necessary.
6. Remove orifice (key 19) and O-ring (key 17). Inspect the parts for damage or wear and replace if necessary. Lightly lubricate the O-ring and place in the body (key 16). Install the orifice.
1. Disconnect pilot supply filter regulator and remove it from the line.
2. Remove cap screws, washers and nuts (keys 2, 9 and 10) from body (key 7) and separate upper and lower covers (keys 11 and 19) from the body (key 7). When separating the covers from the body, be aware of loose components: (keys 1, 3, 4, 8, 12, 18, 20 and 21).
3. Remove and inspect O-ring (key 13) for damage or wear and replace if necessary. Lightly lubricate the O-ring before placing it back in the filter cover (key 11).
4. Clean filter nets (key 8). Replace filter pad (key 12).
5. Inspect diaphragm (key 18) for damage or wear and replace if necessary. Check the seating surface of the screw unit (key 17) for erosion, scratches, spurs or other damage and replace if necessary.
6. Unscrew and remove the regulator seat (key 5). Inspect O-ring (key 6) for damage or wear and replace if necessary. Lightly lubricate the O-ring and place it on the regulator seat.
7. Pull pad holder unit (key 15) out of the body (key 7). Inspect the seat for damage, replace if necessary.
8. Set the pad holder unit (key 15) on the spring (key 14) and insert the regulator seat (key 5). Tighten the regulator seat until it stops.

Type SA/2 (Figure 4)

PRX Series

Table 4. Type PRX/120 Connections

CODE	UNLOADING OR BOOT STYLE	TWO-PATH OR LOADING STYLE
A	Downstream Sense Line	Downstream Sense Line
B	Outlet discharge	Pilot feed
S	Pilot feed	Outlet discharge
L	To regulator loading pressure chamber	To regulator loading pressure chamber

- Lightly lubricate the outer and inner rims of the diaphragm (key 18). Place the diaphragm assembly on top of the regulator seat (key 5). The screw unit (key 17) will slide into regulator seat (key 5). Use care to avoid damage to parts when reassembling.
- Set the spring (key 1) on top of the nut (key 21).
- Align the regulator cover (key 19) over the body (key 7) with the sense port (V) opposite the pilot supply port (R).
- Place the filter pad (key 12) and filter nets (key 8), one on each side of the filter pad, on the filter cover (key 11).
- Pick up the body (key 7) and place it on the filter cover (key 11) with the inlet port (M) aligned vertically with the sense port (V).
- Insert cap screws (key 2). Place washers (key 9) and nuts (key 10) on the end of the cap screws. Tighten the nuts.

Parts Ordering

Each pilot type in PRX Series is assigned a serial number, which can be found on the nameplate. Refer to the number when contacting your local Sales Office for technical information or when ordering parts. When ordering parts, also be sure to include the complete 11-character part number.

Type SA/2 parts can also be ordered. Please provide the 11-character part number and the technical information stamped on the nameplate when contacting your local Sales Office.

Parts List

PRX Series Pilots (Figure 2)

Key	Description	Part Number
	Parts Kits	
	Elastomer Parts Kits	
	Without Disk	
	(include keys 4, 5, 14, 17, 18, 25 and 28)	
	Nitrile (NBR)	RPRX00X0N12
	Fluorocarbon (FKM)	RPRX00X0F12
	With Disk	
	(includes keys 4, 5, 14, 17, 18, 22, 25 and 28)	
	Nitrile (NBR)	RPRX00X0N22
	Fluorocarbon (FKM)	RPRX00X0F22
1	Adjusting Screw, Stainless steel	M0253340X12

Key	Description	Part Number
2	Locknut	M5036008X12
3	Cap, Steel	M0253350X12
4*	Upper Cover O-ring (1 required for Type PRX/120 or PRX/125, 2 required for Type PRX/120-AP or PRX/125-AP)	
	Nitrile (NBR)	M6010178X12
	Fluorocarbon (FKM)	M6020112X12
5*	O-ring	
	Nitrile (NBR)	M6010005X12
	Fluorocarbon (FKM)	M6020001X12
6	Upper Spring Seat, Stainless steel	M0253360X12
7	Spring	See Table 1
8	Upper Cover, Steel	M0298540X12
9	Lower Spring Seat, Stainless steel	M0253380X12
10	Machine Screw, Zinc-plated steel (12 required)	M5011018X12
11	Washer (14 required)	M5055001X12
12	Filter	M4500367X12
13	Upper Diaphragm Plate, Stainless steel (2 required)	M0253390X12
14*	Diaphragm	
	Nitrile (NBR)	GG05785X012
	Fluorocarbon (FKM)	GG05785X022
15	Lower Diaphragm Plate, Stainless steel	M0253410X12
16	Body, Steel	M0253310X12
17*	Orifice O-ring	
	Nitrile (NBR)	M6010003X12
	Fluorocarbon (FKM)	M6020126X12
18*	Lower Cover O-ring (2 required)	
	Polyurethane (PU)	M6010098X12
	Fluorocarbon (FKM)	M6020132X12
19	Orifice, Steel	M0253440X12
20	Nut, Steel	M5002004X12
21	Lower Cover, Steel	M0298600X12
22*	Disk	
	Polyurethane (PU)	ERAA11220A0
	Fluorocarbon (FKM)	M0279950X12
23	Stem, Steel	M0253430X12
24	Nameplate	-----
25*	Stem O-ring	
	Nitrile (NBR)	M6010223X12
	Fluorocarbon (FKM)	M6020133X12
26	Upper Diaphragm Nut	M5028005X12
27	Damper Adjusting Screw with Hole, Stainless steel	M0253480X12
28*	Restrictor/Damper O-ring (2 required)	M6020054X12
29	Damper/Restrictor Plate	
	Types PRX/120 and PRX/120-AP	M0254400X12
	Types PRX/125 and PRX/125-AP	M0257930X12
30	Ring Nut (2 required)	M0253490X12
31	Nameplate Screw	M5061001X12
32	Restrictor Adjusting Screw with Hole	M0253480X12
33	Plug (Types PRX/125 and PRX/125-AP Only)	M0257920X12
34	Plug (Types PRX/125 and PRX/125-AP Only), Brass	M4500328X12
35	Spring Barrel Extension for AP, Steel	M0274100X12

*Recommended Spare Part

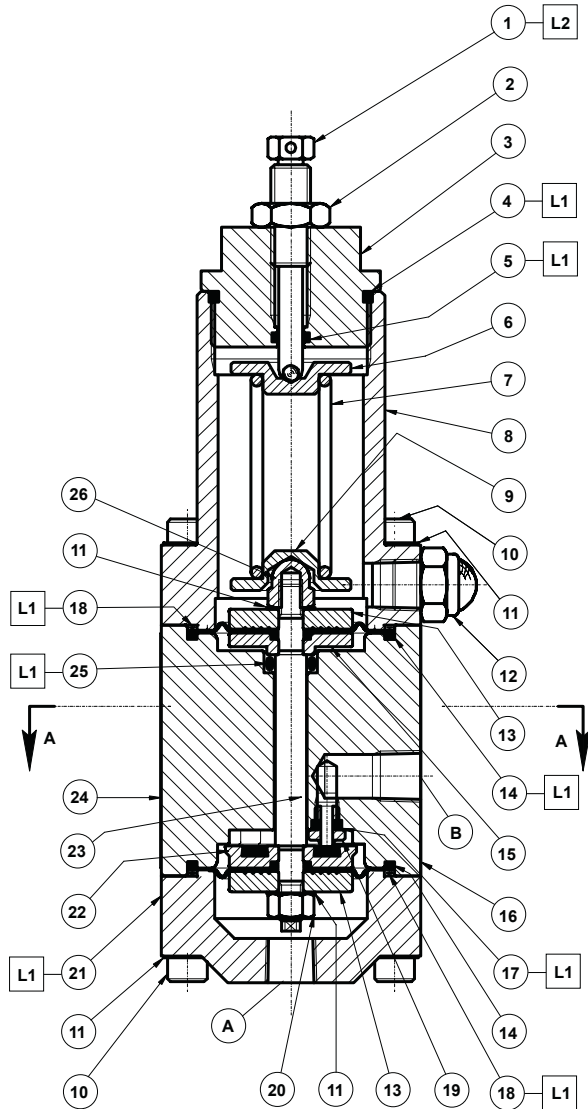

TYPES PRX/120 AND PRX/125 PILOT ASSEMBLY

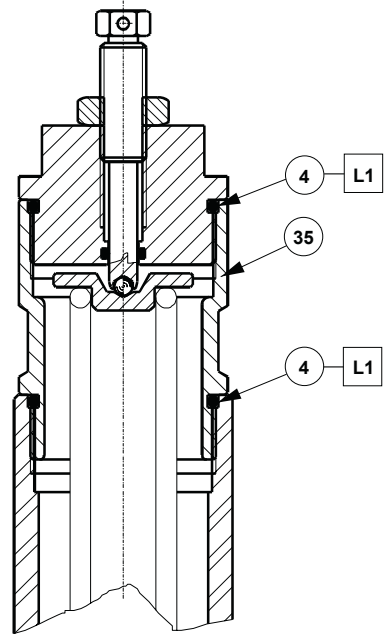

AP VERSION

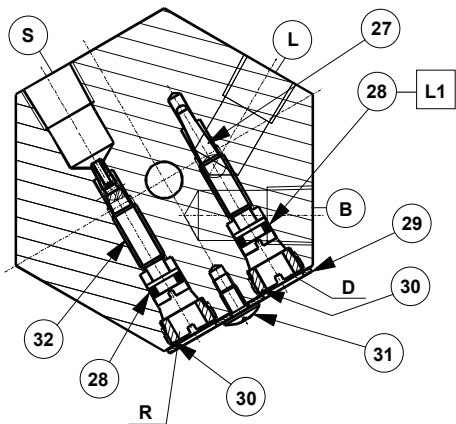

TYPE PRX/120 VERSION - SECTION A-A

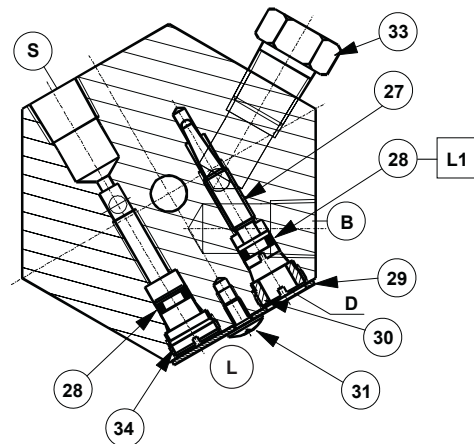

TYPE PRX/125 VERSION - SECTION A-A

- APPLY LUBRICANT⁽¹⁾
- L1 = LITHIUM POLYMER TYPE LUBRICANT (MULTI-PURPOSE GREASE)
- L2 = ANTI-SEIZE LUBRICANT

1. Lubricants must be selected such that they meet the temperature requirements.

Figure 2. Types PRX/120 and PRX/125 Pilot Assemblies

PRX Series

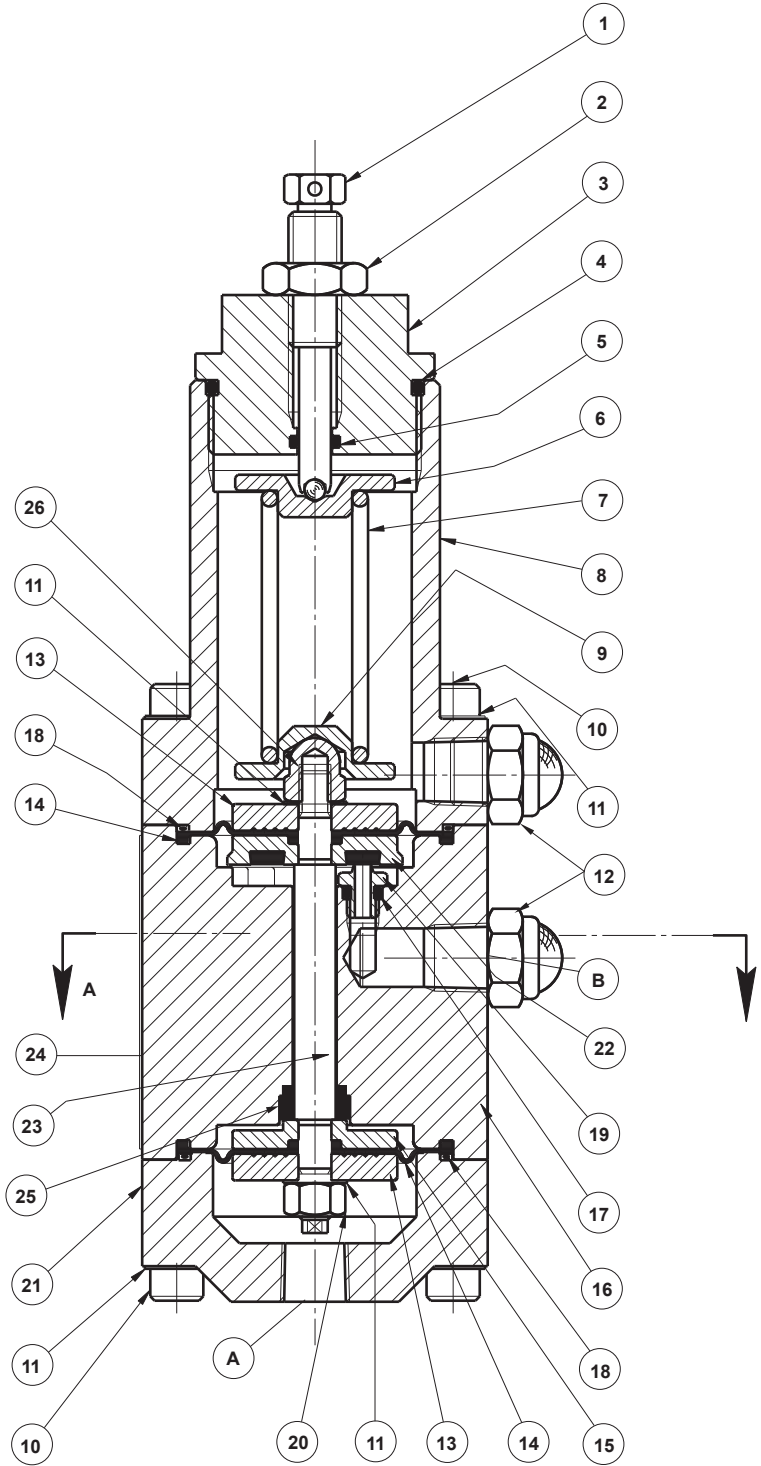
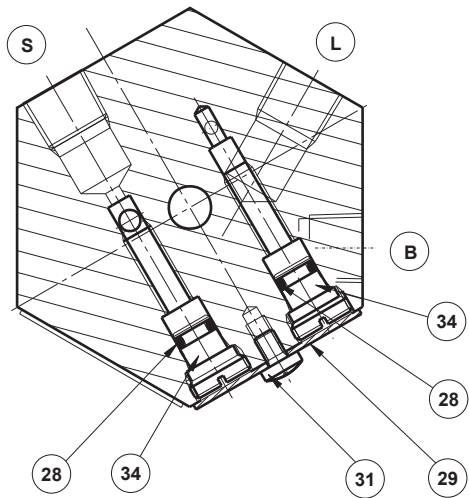
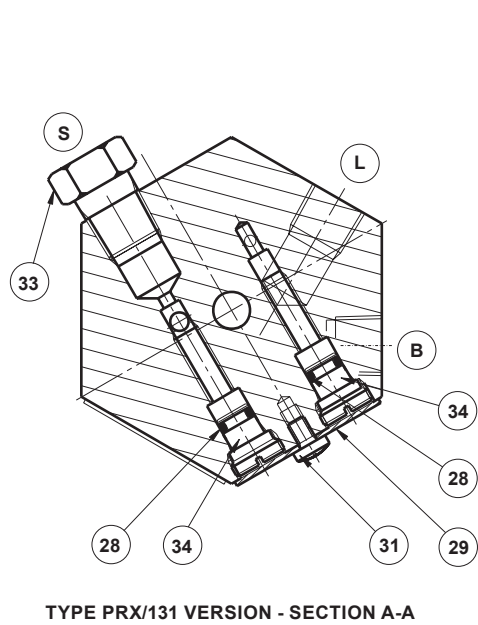
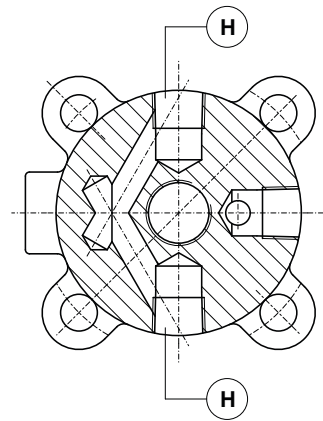
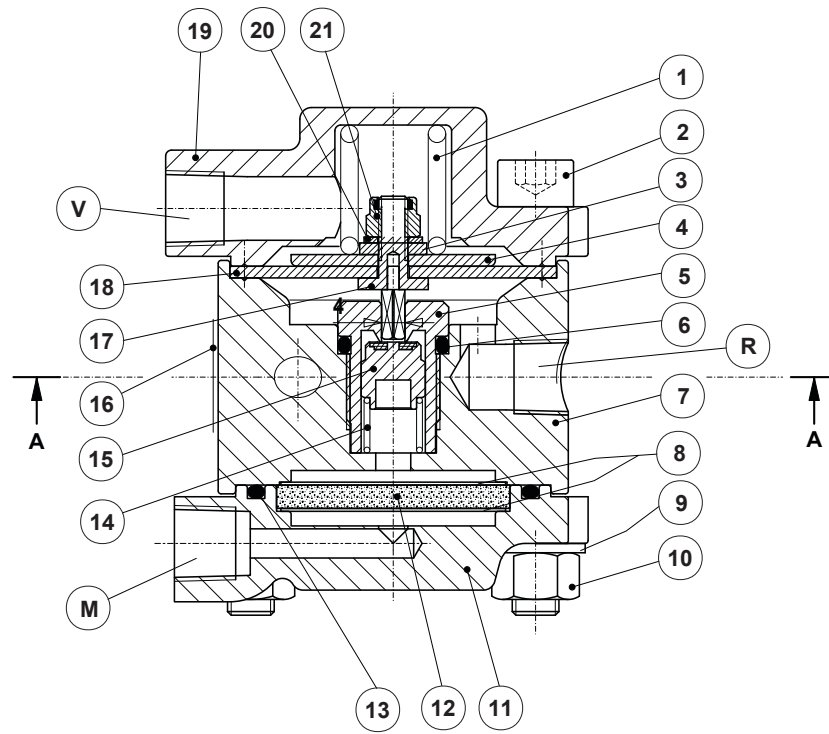

Figure 3. Types PRX/131 and PRX/182 Pilot Assemblies



SECTION A-A

LM/1162

H - WATER INLET/OUTLET
 M - UPSTREAM OF THE REGULATOR
 R - TO THE FEEDING OF THE PILOT
 V - DOWNSTREAM OF THE REGULATOR

Figure 4. Type SA/2 Assembly

PRX Series

Type SA/2 Pilot Supply Filter Regulator (Figure 4)

Key	Description	Part Number	Key	Description	Part Number
	Parts Kits		9	Washer (4 required)	M5057002X12
	Elastomer Parts Kits		10	Nut (4 required)	M5060005X12
	(includes keys: 6, 12, 13, 15 and 18)		11	Filter Case, Steel	M0174411X12
	Nitrile (NBR)	GD89995X012	12*	Felt	M0102210X12
	Fluorocarbon (FKM)	GD89995X022	13*	O-ring	
1	Spring	M0192560X12		Nitrile (NBR)	M6010095X12
2	Socket Head Cap Screw (4 required)	M5058003X12		Fluorocarbon (FKM)	M6020069X12
3	Washer	M0248490X12	14	Spring	M0105970X12
4	Plate	M0174470X12	15*	Disk Holder	
5	Regulator Seat	M0200830X12		Polyurethane (PU)	M0233370X12
6*	O-ring			Fluorocarbon (FKM)	M0279850X12
	Nitrile (NBR)	M6010013X12	16	Nameplate	-----
	Fluorocarbon (FKM)	M6020006X12	17	Screw Unit	M0200790X12
7	Body, Steel	M0297920X12	18*	Diaphragm, Nitrile (NBR)	M0174460X12
8	Filter Screen (2 required)	M0102200X12	19	Regulator Case, Steel	M0239890X12
			20	Spring Washer	M5001003X12
			21	Nut	M5006012X12

*Recommended Spare Part

 Webadmin.Regulators@emerson.com

 [Facebook.com/EmersonAutomationSolutions](https://www.facebook.com/EmersonAutomationSolutions)

 [Tartarini-NaturalGas.com](https://www.tartarini-naturalgas.com)

 [LinkedIn.com/company/emerson-automation-solutions](https://www.linkedin.com/company/emerson-automation-solutions)

 [Twitter.com/emr_automation](https://twitter.com/emr_automation)

Emerson Automation Solutions

Americas

McKinney, Texas 75070 USA
T +1 800 558 5853
+1 972 548 3574

Europe

Bologna 40013, Italy
T +39 051 419 0611

Asia Pacific

Singapore 128461, Singapore
T +65 6777 8211

Middle East and Africa

Dubai, United Arab Emirates
T +971 4 811 8100

D103231X012 © 2008, 2020 Emerson Process Management Regulator Technologies, Inc. All rights reserved. 09/20.

The Emerson logo is a trademark and service mark of Emerson Electric Co. All other marks are the property of their prospective owners. Tartarini™ is a mark owned by O.M.T. Officina Meccanica Tartarini s.r.l., a business of Emerson Automation Solutions.

The contents of this publication are presented for informational purposes only, and while every effort has been made to ensure their accuracy, they are not to be construed as warranties or guarantees, express or implied, regarding the products or services described herein or their use or applicability. All sales are governed by our terms and conditions, which are available upon request. We reserve the right to modify or improve the designs or specifications of such products at any time without notice.

Emerson Process Management Regulator Technologies, Inc does not assume responsibility for the selection, use or maintenance of any product. Responsibility for proper selection, use and maintenance of any Emerson Process Management Regulator Technologies, Inc. product remains solely with the purchaser.

