

automation ^{11.19}

The B&R Technology Magazine

Robotics

Simplifying machine-robot integration

Smart factory Automated with a human touch

Asset Performance Monitor Easily in touch with your machines

Digital twins Virtual meets reality

PERFECTION IN AUTOMATION
A MEMBER OF THE ABB GROUP





INTEGRATED MACHINE VISION

More than embedded

Complete portfolio: www.be-automation.com/vision

Expanding the field of vision



Be-Process-Production



editorial

publishing information

automation:
The B&R technology magazine, Volume 19
www.br-automation.com/automation

Media owner and publisher:
B&R Industrial Automation GmbH
B&R Strasse 1, 5142 Eggelsberg, Austria
Tel.: +43 (0) 7748/6586-0
automation@br-automation.com

Managing Director: Hans Wimmer

Editor: Alexandra Fabitsch
Editorial staff: Craig Potter
Authors in this edition:
Carola Schwankner, Carmen Klingler-Deiseroth,
Franz Joachim Rossmann, Josef Neced, Ninad
Deshpande, Stefan Hensel, Stephen Ratcliffe,
Thomas Schmertosch, Sebastian Brandstetter

Graphic design, layout & typesetting:
Linie 3, www.linie3.com
Printing: VVA Vorarlberger Verlags-
anstalt GmbH, Dornbirn
Edition: 100,000
Published at: B&R Strasse 1
5142 Eggelsberg, Austria
Cover photo: B&R

All articles published in this magazine are protected by copyright. Translation, reproduction and duplication are prohibited without the expressed permission of the publisher. B&R assumes no liability for any errors they may contain.

Follow us    

Our data protection notice can be found under <http://www.br-automation.com>. If you no longer wish to receive this customer magazine, please let us know by sending an email to automation@br-automation.com.



Dear Reader,

From the outside, robots appear to be – quite literally – the embodiment of automation. All the more perplexing, therefore, to look under the hood and discover that robotics control and machine control have been operating for a long time as two completely independent systems.

More than a decade ago, machine builders approached us and asked if it would be possible to control their robots directly from the machine's PLC. We responded by expanding our existing portfolio of motion control functions with a comprehensive set of robotics software. That opened us up for the second step: connecting our drive technology to existing third-party robots.

Although this worked well from a technical standpoint, there remained one key request that we couldn't fulfill: the ability to supply our customers with machine automation and robotics from a single source.

That's why we're so excited to announce that, with ABB robots fully incorporated in our portfolio, we're finally able to do just that. Machine builders will now be able to buy their robots from B&R right along with all their control, I/O and drive components – a uniquely comprehensive offer you won't find anywhere else on the market.

On the following pages, you'll learn all about the benefits of integrated robotics.

Happy reading,



Sebastian Brandstetter
Product Manager - Integrated Robotics

contents



04



12



26

→ cover story

04 Simplifying machine-robot integration
B&R now offers ABB robots as an integral part of its automation system.

→ report

08 Integrated vision – Quality in process and product
Incorporating machine vision in manufacturing is now remarkably easy. *Spilker* offers its customers a new solution based on B&R's integrated camera solution.

12 Milling like the masters
Kunzmann has revamped its manually operated universal milling machines. B&R technology with integrated safety has eliminated operating delays, reduced space requirements and made the machines easier to install and maintain.

22 Digitalization – A pressing matter
Far too often, the data generated by machines and processes goes largely unused. *Dorst* uses B&R technology to offer its customers particularly easy access to this treasure trove of information.

30 Getting serious about serialization
EU directives mandate serialization and verification of pharmaceutical packaging. New Pharma 2D machines from *Intrex* quickly adapt to on-site requirements thanks to hardware and software from B&R.

38 Fault response in minutes, not days
With VPN-based remote maintenance from B&R, *Maximator* reduced costs, streamlined commissioning and brought fault response times from days down to minutes.

48 Joining together for reduced emissions
Lightweight car bodies help reduce CO₂ emissions. *EJOT* developed the new EJOWELD process for joining the advanced materials involved.



30



48



38



52

→ **technology**

- 16 **The next best thing to a crystal ball**
Get proactive about high availability: An investment in predictive maintenance can really pay off.
- 26 **Virtual meets reality**
To prevent flaws in the design of a new machine from going unnoticed until commissioning, OEMs are increasingly relying on simulation with digital twins.
- 34 **Easily in touch with your machines**
When it comes to after-sales contact, many OEMs are happy to assume that no news is good news. The relationship ends with delivery – along with any potential for further revenue. Until now, that is.
- 44 **Automated with a human touch**
Asked to imagine a digital factory, we likely picture a sterile shop floor devoid of human operators. Connected as the smart factory may be, however, it still relies on a human touch.

→ **news**

- 20 **B&R products speak OPC UA over TSN**
B&R enables vendor-agnostic communication from sensor to cloud.
- 21 **OPC UA over TSN implementation**
B&R introduces TSN machine switch for converged real-time networks.
- 42 **The power of a PC**
B&R's industrial controllers take performance to a whole new level.
- 43 **Austria's largest private solar power station**
B&R expands photovoltaic system to 1.5 megawatts.
- 52 **New X20 generation for the future of automation**
B&R presents new controllers with OPC UA over TSN and Intel processors.

Integrated robotics

Simplifying machine-robot integration

Integrating robots into a machine has historically been such a complex undertaking that many machine builders would rather avoid the topic all together. While they may have had good reason for this hesitation in the past, things have just gotten a whole lot easier now that ABB and B&R have jointly developed a solution that integrates ABB robots into the B&R machine control system.

Machine and robot become one.



Machine builders face increasing market pressure to make their machines simultaneously more flexible, more cost effective and more productive. What seem to be conflicting goals can be resolved using robots. The only catch: Robots typically require copious programming and are difficult to integrate into the machine's automation system. "Robotics is a highly advanced discipline," explains Sebastian Brandstetter, B&R's product manager for integrated robotics. "Until now, however, robots and machines were independent systems." Robots have been a standard feature of large automobile production lines for decades, yet rarely can they be found as an integral component of a machine.

Two independent systems...

Some years ago, machine builders began integrating robots directly into the machine process to make their machines more flexible. Yet this flexibility came at a high cost, and the resulting synchronization left much to be desired. "A robot is a self-contained

system," explains Brandstetter. It has its own controller and its own control cabinet. Engineering, diagnostics and maintenance are all performed using dedicated systems. Communication with the machine controller goes through an interface - which in many cases is even hardwired.

For those in search of a more expedient way to integrate robotics, the answer is clear: these two systems must meld into one. "We need to have one simple architecture," summarizes Brandstetter.

... become one

"We now offer ABB robots as an integral part of our automation system," explains Brandstetter. Throughout engineering and operation, working with the robots is just the same as with any other B&R automation component. "For machine developers, it makes no difference whether they have to integrate a single motion control axis or an entire robot into the machine," notes Brandstetter.

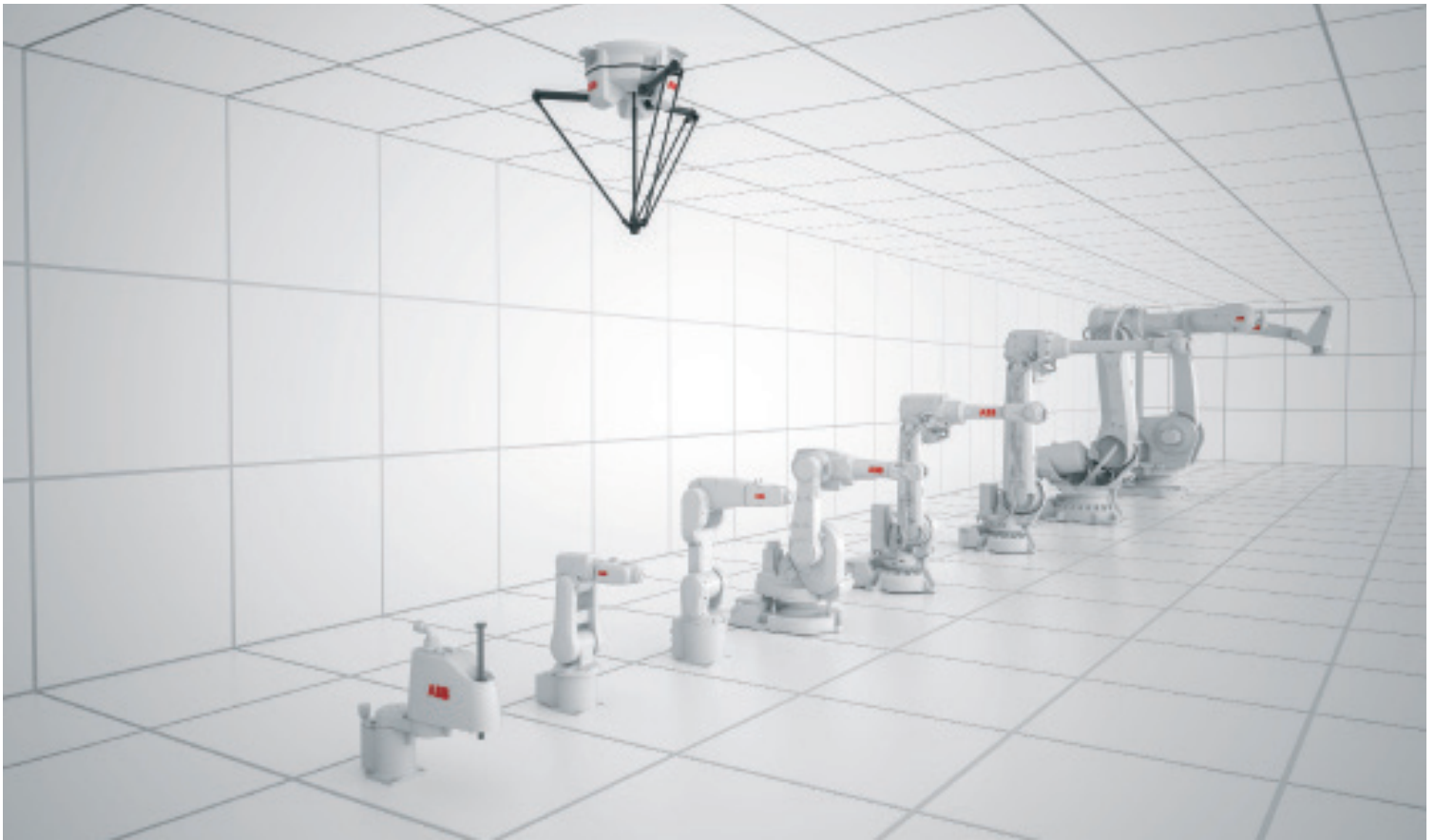

B&R customers have a selection of articulated arm, SCARA, delta and palletizer robots in various sizes and with various payloads.

“The tools, the engineering environment, the B&R contact person: they’re always the same.”

A familiar environment

The integration eliminates the need for a dedicated robotics controller, a separate control cabinet and a specialist for a specific robotics language. The user has access to all the familiar machine programming languages like Ladder Diagram, Structured Text and C/C++.

In order to further facilitate the integration of ABB robots into machine automation solutions, B&R also provides pre-configured software modules that make robotics applications even easier for machine builders to create. B&R’s mapp Robotics includes standard functions for control and commissioning as well as advanced functions such as feed-forward control, compressor and work-

space monitoring. This allows the user to implement complex and highly dynamic applications without having to write countless lines of code. Development times are reduced dramatically.

Tight synchronization

“More user-friendly programming is a decisive advantage that comes from merging robotics with machine control,” says Brandstetter. “Another key difference is the unprecedented precision that can be attained in the synchronization between the robot and other machine components.” This becomes possible when you no longer need to use separate hardware, separate communication networks and separate applications. The fact that all axes and sensors communicate on a common network increases precision to the previously unimaginable microsecond range. “This opens up a whole new world of possibilities,” notes Brandstetter.



Sebastian Brandstetter
Product Manager -
Integrated Robotics, B&R

“For machine developers, it makes no difference whether they have to integrate a single motion control axis or an entire robot into the machine.”



Photos: ABB, B&R



ABB robots are fully integrated in the B&R system.

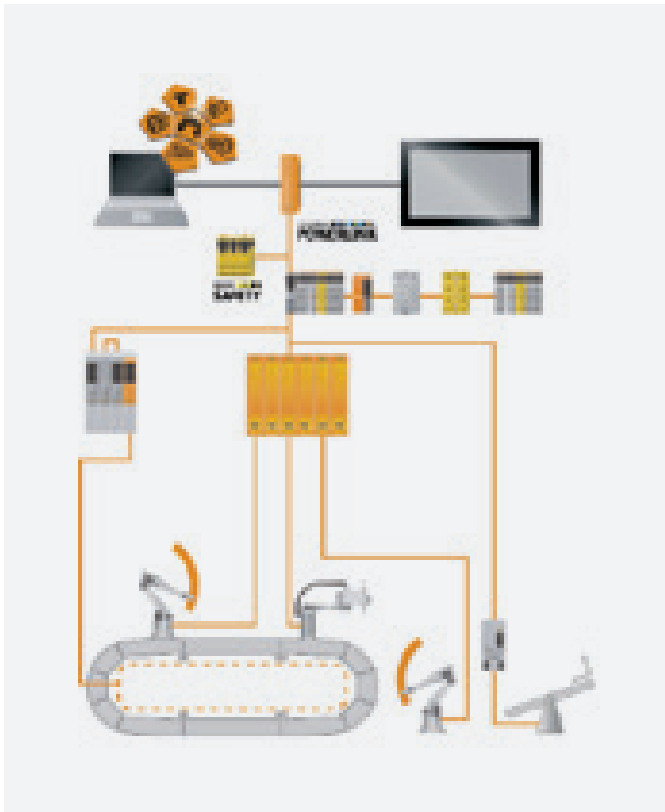

Like all other automation components, the robots are fully integrated in the B&R system.

Parallel processing

A workpiece on a workpiece table, for example, used to be positioned and come to a complete stop before being machined by a robot. Now, the machining can take place while both table and robot are in motion. The machine application can automatically calculate optimized motion profiles and significantly reduce the overall processing time. Productivity goes up. "Of course, the same principle also applies when you combine an ABB robot with a track system like ACOPOStrak," adds Brandstetter.

The robot can process a workpiece while it moves at high speed along the track. The track becomes simply an additional axis that is included in the calculation of the motion profile.

Synchronization with sensors

Synchronization between sensors and robot motion also becomes easier. The result of a quality inspection with a B&R vision camera can be converted into a control command for the ABB robot in less than a millisecond. Defective workpieces can be removed from the production process without any manual intervention or slowing down the process. "This approach can significantly increase the machine's output," says Brandstetter.

Of course, the comprehensive simulation options available in the B&R system are available for the robotics as well. With a digital twin, the user can simulate and optimize the machine's entire motion sequence, including the robotics, before the machine is even built. Development becomes both faster and cheaper. ←

Coating and converting

Integrated vision – Quality in process and product

For B&R customers, implementing machine vision functions in new or existing manufacturing systems no longer comes with the prohibitive overhead in time and costs. Among the first to offer its customers a solution based on B&R's integrated machine vision technology is Spilker, manufacturer of punch presses and complete lines for the printing, labeling, automotive, pharmaceutical and packaging industries.

"B&R's integrated machine vision system and the functions it enabled us to implement are an absolute highlight of our pilot system," reports Spilker sales manager Mark Possekel. "Usually, however, such highlights come with a bitter aftertaste when you realize how much they cost. That's where this solution is different – regardless of whether it's a new development or a retrofit. It's great for our customers, which of course is great for us." These praises were echoed by customers who got a first look at the new vision solution at the 2019 ICE exhibition for paper, film and foil converting in Munich. For Possekel, the positive feedback was certainly pleasing, if not surprising – after all, the solution is a perfect fit for what many Spilker customers had been requesting.

Demand for vision functions on the rise

Spilker found its niche creating custom converting machines and

Photo: F. Rohmann, Spilker



punch presses. For Possekele and Managing Director Henrik Spilker, expanding on the company's years of automation know-how with a more in-depth approach to machine vision was an obvious step. The exhibition offered the perfect opportunity to present the first applications yielded by the endeavor. After evaluating numerous potential suppliers, the company selected two products for its pilot system. In addition to the B&R solution, the pilot system also featured an inspection solution from a well-known specialist in the area of quality assurance for web processing.

"What's good about the inspection system are its preprogrammed standard functions, including pressure control and the ability to compare live images against predefined images of an ideal product. On top of that, it's also very easy to operate," adds Dirk Starke, programmer and automation specialist at Spilker. "The downside,

though, is that it only tells you whether the product is good or bad, without providing the underlying measurements, which can only be obtained indirectly and at much higher cost. It also lacks an interface for direct communication with the line controller."

Conventional vision systems: Too complex

Seeking to help its customers cope with increasingly stringent requirements for documentation and quality assurance, Spilker also evaluated suppliers of conventional machine vision solutions. "These suppliers offer systems in our price range that provide measurements we can use as setpoints in our processing stations or pass on to our customers for their documentation," explains Possekel. "The problem with these standalone and PC-based solutions, however, is the difficulty of integrating them into the machine control environment. They also require intensive



Spilker equipped its pilot system with machine vision functions in only a few days using the Smart Sensor from B&R – and demonstrated the results live at the ICE exhibition in March 2019.



The B&R Smart Sensor used by Spilker provides position values for each label in real time, which are then used to control the system's die cutters.

training and becoming accustomed to a new engineering environment. Especially with the exhibition rapidly approaching, that could have easily become a problem.”

A stroke of luck: Integrated vision from B&R

Understandably, Spilker's experts took notice when they heard B&R was working on a machine vision solution. The machine builder had been using B&R's seamlessly integrated automation portfolio to develop their own automation solutions in-house rather than relying on external partners. That meant its developers were already comfortable working with B&R products and using the Automation Studio engineering environment – which is also where they would be configuring the camera.

“The announcement from B&R came as a stroke of luck for us,” recalls Spilker. “We immediately volunteered to serve as a pilot customer. B&R offers a rare package that is both extremely powerful, and also suitable for newcomers to vision technology and unbelievably easy and inexpensive to integrate.”

After preliminary discussions with the local B&R office, where Spilker presented the production task envisioned for the exhibition demo and the measurements that would be required, things progressed quickly.

“B&R's vision experts recommended a 1.3 megapixel Smart Sensor with integrated lighting,” describes Spilker. “And we followed that recommendation.”

Integrated lighting and image processing

Image processing is performed entirely in the sensor, leaving only the evaluation of the inspection results up to the machine controller. Triggering precision of only one millisecond allows Spilker to design very tight control loops for monitoring and adjusting

punch position – further increasing process stability. The 16 built-in high-performance LEDs operate with exposure times well below 100 milliseconds. Short exposures minimize interference from external light sources, reduce image processing time and make it possible to capture fast-moving objects. The Smart Sensor comes equipped with a variety of vision functions, including code reading, blob analysis, matching, OCR and measurement.

To further ease Spilker's learning curve with the new camera system and accelerate development, B&R provided Starke's team with additional support. Within hours, they had made rough settings based on production samples and used the vision system's integrated matching function to set up a number of required measurement functions. On the pilot system, these functions deliver three position parameters. If the deviation grows too large, the tools at the processing stations are adjusted accordingly.



Henrik Spilker
Managing Director, Spilker GmbH

“The announcement from B&R came as a stroke of luck for us. B&R offers a rare package that is both extremely powerful, and also suitable for newcomers to vision technology and unbelievably easy and inexpensive to integrate.”



The Smart Sensor is directly integrated in the Automation Studio development environment and communicates via OPC UA, allowing measurements to be used as real-time variables in the control and HMI applications.



With HTML 5 and mapp Technology, Spilker is able to offer users both traditional HMI operation and web-based operation using smartphones or tablets.

On the pilot system, 50 x 70 millimeter self-adhesive labels are rotary-punched two at a time in a roll-to-roll process, with additional holes then punched in two places before a sticker is applied. Machine components such as the winder, cross cutter and rotary die cutter are mounted on the back panel of the machine. The open machine layout provides easy access to individual components, maximal insight into the production process and makes it easy to mount the Smart Sensor.

Integral component of Automation Studio

Since the Smart Sensor is integrated directly into the engineering environment for the controller and communicates via OPC UA, there are no interfaces to be programmed. With position, orientation and other data available to the controller in real time, the drives are able to react quickly and precisely to any deviations. "We developed the routines for processing measurements from the Smart Sensor in the controller, programmed the control loops and the visualization of the machine vision functions in the machine's HMI application," says Starke. "Working with the Smart Sensor confirmed that it is a highly integrated solution that is seamlessly incorporated in B&R's engineering landscape and tailored to the needs of automation developers."

Done in days

This fact was borne out by the extremely short implementation time. All together, it took the B&R experts and Spilker's team less than four days to get the pilot system's vision functions up and running. And the functions performed perfectly the first time they started up the system. In light of the positive experience and the praise received from exhibition visitors, Starke is confident that B&R machine vision will play an important role in the future of his company. "Particularly in cases where conventional sensors run up against their limits - detecting complex error scenarios or capturing positions - the Smart Sensor is the perfect solution to have in our portfolio." ←

Extensive machine vision functions

BSR's mapp Vision software solution includes an extensive selection of machine vision functions, encapsulated in easily configurable software blocks. There's no need for the programming work that would traditionally be necessary.

Code detection (identification)

mapp Vision can handle more than 40 different code types, including all the most common 1D and 2D codes. The function is self-optimizing and enables reliable results even at very high speeds.

Text detection (OCR)

The integrated character recognition function works with a deep learning algorithm. The OCR function is therefore very reliable and enables high-speed reading even with poor image quality.

Shape detection (blob)

Shape detection determines the size of the shape and its center of gravity with micropixel precision. It also provides information about orientation and average grey value.

Object comparison (matching)

The matching function easily identifies objects, their position and orientation. In addition to edge-based matching, a correlation-based variant is also available.

Measurement (metrology)

With Metrology, mapp Vision provides a powerful and highly accurate measuring instrument. Edges along lines or circle segments are measured with subpixel accuracy.

Machine tool building

Milling like the masters

At the beginning of 2019, renowned milling machine manufacturer Kunzmann relaunched its line of manually operated universal milling machines, which are particularly popular in vocational training and workshop production. With BSR technology and integrated safety functions such as Safe Brake Test (SBT), Kunzmann was able to reduce axis switching times, save space in the control cabinet and make the machines easier to install and service.

Photo: iStock



At the end of August 2019, more than 1,600 young trade professionals gathered in the Russian city of Kazan to put their talents to the test at the WorldSkills competition. The world's best millers were crowned in the categories "Polymechanics and Automation", "Manufacturing Team Challenge", "Prototype Modelling" and "Industrial Mechanics Millwright". The competitions were conducted using fifteen WF 410 M milling machines provided by renowned German machine tool builder Kunzmann. Like its big sister, the WF 610 M, this machine is 100% manually operated. They are known for their long service life, high machining precision and advanced safety features as well as being ergonomic and easy to operate.



More than 10,000 of Kunzmann's manually-operated milling machines are in service around the world.



Powerhouse: By replacing an induction motor with a fanless B&R servo motor, Kunzmann cut the space required for the spindle motor nearly in half.

This makes them perfectly suited for training, prototyping and workshop production. They are standard equipment at many vocational schools and apprentice workshops, but also at many machine tool builders, mold makers and manufacturing OEMs.

Retooled with B&R drives

Kunzmann implemented numerous improvements when it re-ramped its milling machines in early 2019. Among them was a switch to a new drive supplier. "B&R prevailed over other providers with its innovative solutions and an attractive price/performance ratio," says Ralf Guthmann, head of electrical design at Kunzmann. "They also scored points early on with their excellent consulting expertise." B&R employees were able to answer the majority of Kunzmann's questions off-the-cuff during initial exploratory discussions. "That's quite different than experiences we've had in the past," reports Guthmann, "In some cases, they had to send as many as four employees to visit us to achieve the same thing. And

what B&R presented to us was a quantum leap compared to the previous solution."

More efficient milling without switchover times

One of the key improvements that Kunzmann achieved with B&R technology is increased milling efficiency. The safety standards for manual milling machines stipulate that it must be impossible to operate multiple axes simultaneously. Until now, Kunzmann had satisfied this requirement by installing only one controller for the three coordinate axes (X, Y, Z). Whichever axis was required for the next machining step was hooked up to this single-axis controller. This effectively prevented simultaneous activation of two coordinate axes. For the user, however, the time it took to switch between axes caused considerable delays in the machining process. The new generation now uses a three-axis ACOPOS P3 servo drive, so there is no need to switch between the axes and therefore no more waiting for the user. The drive features integrated safety functions, including Safe Brake Test. A PLC from B&R's X20 range, in conjunction with X20 safe I/O modules, reliably prevents simultaneous operation of multiple coordinate axes as required by the standard. The X20 PLC also handles control and monitoring of a single-axis ACOPOS P3 module that drives the spindle of the machine tool. The X20 PLC receives axis setpoints via the analog interface of a Heidenhain CNC controller. The TNC128 functions as the machine's straight-cut controller and user interface.

Dramatic space savings

Another advantage of the B&R solution is the reduced cabinet footprint, as Guthmann explains: "For the first time ever, B&R's integrated safety functions have enabled us to completely dispense



Ralf Guthmann
Head of Electrical Design, Kunzmann

"B&R's solutions and services are well thought out and simplify the installation, commissioning and maintenance of our milling machines."



High runners: The WF 610 M/MA and WF 410 M/MA milling machines are among the Kunzmann machines produced in the largest quantities – with B&R technology on board since early 2019.



Space-saving wonder: ACOPOS P3 shrinks cabinet footprint

with external safety hardware. Together with the compact dimensions of the B&R components, we've significantly reduced the amount of cabinet space required." B&R's three-axis servo drive is smaller than its single-axis predecessor. Converting the machine to 24 V technology also eliminated the need for a transformer, so the electrical engineers were able to completely do away with the mounting plate in the door of the control cabinet.

Kunzmann's mechanical engineers also benefited from the space-saving design of the B&R solutions. "The B&R servo motors we use on the axes and spindle offer a high power density," explains Guthmann. "This is particularly evident in the case of the spindle, where for the first time we're using a servo motor, which by design is already smaller than an induction motor. And since the B&R motor also doesn't require a fan, we've cut our overall space requirements nearly in half." This is not the only design benefit from his point of view: "What impressed me right away and made my job a lot easier was that the B&R offer included a link to technical documentation and CAD data for each product. That's an immense help for designers."

Fully assembled system ready for installation

Kunzmann experts were very pleased with how B&R's application engineers handled the tasks of selecting the components, sizing the drives and programming the PLC. But that's not all. B&R also assembles the milling machine control system, comprising twelve X20 modules, then installs the software, labels the station and finally tests it. "We then purchase a package that includes all the B&R components we need for six machines at a time. That's a significant relief for our internal ordering, assembly and testing processes," says Guthmann.

Last but not least, the change of supplier and the new automation technology from B&R have also made the manual milling machines easier to service and maintain. "The X20 modules consist of three modular components, so it is possible to replace just the terminal block, electronics module or bus module without having to dismantle the rest of the system. It's a really well thought-out solution." Kunzmann can also access the web server of the X20 PLC directly from the Heidenhain controller's integrated web browser to retrieve diagnostic data from B&R's System Diagnostics Manager (SDM). This makes it possible to perform remote maintenance on both the Heidenhain controller and the B&R system via the TNC128's TeleService. "We don't need another PC on site for this and don't have to install any special software or program anything," says Guthmann. B&R's SDM delivers data about the current state of the drives, such as the current speed, position and controller enable values. It is also possible to open and operate the oscilloscope integrated in each drive via SDM, or use its I/O viewer to display the current states of all the I/O channels in the B&R system. This shortens commissioning times by eliminating the need for time-consuming I/O wiring tests.

Transition done right

For Kunzmann, the bottom line is that introducing B&R technology has made it easier to ensure the high level of safety that users have come to expect from their milling machines, while giving them unprecedented design freedom and making the machines much easier to install and maintain. For users, the transition was a seamless one. "Since shipping the first pilot machine in the fall of 2018 we haven't received a single bit of negative feedback. That's a good indication we did everything right." ←

The next best thing to a crystal ball

ISSUE IDENTIFIED

When a machine fails or has to be stopped for maintenance, it comes with a hefty price tag. And that's not just the cost of repair work and replacement parts, but rather the revenue that is lost every minute that a line is not productive. By helping to detect impending damage before it occurs, an investment in predictive maintenance can really pay off. In addition to preventing revenue loss, predictive maintenance extends the life of the machine and even opens up new business models.

In continuous web machines like those used in printing and packaging, sheet of material is guided through a labyrinth of rollers. A mechanical imbalance or increased bearing friction in one of those rollers could introduce uncontrolled oscillations that interfere with web tension throughout the machine. This has a negative effect on product quality and could even lead to an outright machine failure. An effective way to keep this from happening is with a predictive maintenance system, which is able to detect potential faults before they occur. Imbalances or worn bearings are identified in time to plan the necessary repairs before the roller fails and brings the machine to a halt. After all: only if machinery and equipment is functioning properly is it possible to meet financial targets.

Avoid downtime

A predictive maintenance solution relies on a variety of data collected from the machine. This data is collected through a process of continuous condition monitoring, then analyzed and evaluated so that the predictive maintenance system can calculate the pre-

Predictive maintenance provides comprehensive insight into the health of a machine and forecasts the probability of component failure, helping to identify damage before it becomes critical.



mapp
CONTROL

Alarms

Alarms History

Alarms

17 118		Water Detected
17 124		Lubrication Oil Level Low
18 000		IO Module Communication Error
20 000		Emergency Stop Present

Help

Class	Conveyor #1 reports low oil level
Report	Roll off to maximum level



To make a reliable statement about the condition of a machine, the first step is to collect as much data as possible and evaluate it using intelligent analysis algorithms.

cise probability of certain events occurring. "Not only does predictive maintenance save costs, it also helps maximize productivity – because you're replacing components before they would begin to impact the machine's performance," explains Martin Staudecker, software development expert in the area of closed-loop control at B&R. Predictive maintenance can do much more, however, than simply monitor the behavior of a single roller. It provides comprehensive insight into the health of the entire machine and forecasts the probability of component failure. Motor speed, noise level and temperature can all be recorded, and any unusual vibrations or mechanical imbalances can be detected in their earliest stages. It's

also possible to perform detailed vibration analysis of specific components that are prone to wear.

Intelligent analysis algorithms

To make a reliable statement about the condition of a machine, the first step is to collect as much data as possible and evaluate it using intelligent analysis algorithms. The more data the system has to work with, the better it is able to detect impending faults before they occur. "That means, however, that you need to find a system that can store and analyze such enormous volumes of data." In addition to condition data from the machine itself, predictive maintenance can also make use of parameters from the

surrounding environment, such as temperature and humidity. This data must also be incorporated into the analysis in order to maximize the reliability of its predictions. B&R's predictive maintenance utilizes special I/O modules for condition monitoring, paired with sophisticated analysis algorithms from its mapp Technology toolkit. The easy-to-configure condition monitoring modules pinpoint areas where service may be needed. What sets B&R's modules apart is their built-in vibration analysis capability. Data received from the condition monitoring modules can easily be prepared and utilized to optimize existing processes. As part of B&R's X20 controller family, these modules are fully compatible with any machine control topology.

Results-oriented data processing

The collected data is evaluated using the sophisticated analysis algorithms of the mapp Control software package. "High-performance, results-oriented data processing is the key to effective analysis," notes Staudecker. "And that's exactly what mapp Control makes possible." The bulk of the analytics can be performed directly on the controller. That greatly reduces the volume of data to be transferred, since it's only the results that need to be passed on.

Autotuning for fault prediction

Another way to detect faults early is using tuning procedures. "mapp Control includes model-based tuning methods that identify system behavior then create a suitable controller on that basis," explains Staudecker. When tuning is performed at regular intervals, not only are the control parameters kept up to date, but any changes in system behavior are brought to light. Based on deviations in static properties, system dynamics or resonant frequencies, it is possible to draw conclusions about developments in the machine process, leaks or worn components.

Detect wear

Predictive maintenance allows operators to replace worn components when it is most convenient, rather than interrupting ongoing production. Over time, mechanical wear



Martin Staudecker
Closed-loop Control Expert, B&R

"Not only does predictive maintenance save costs, it also helps maximize productivity – because you're replacing components before they would begin to impact the machine's performance."

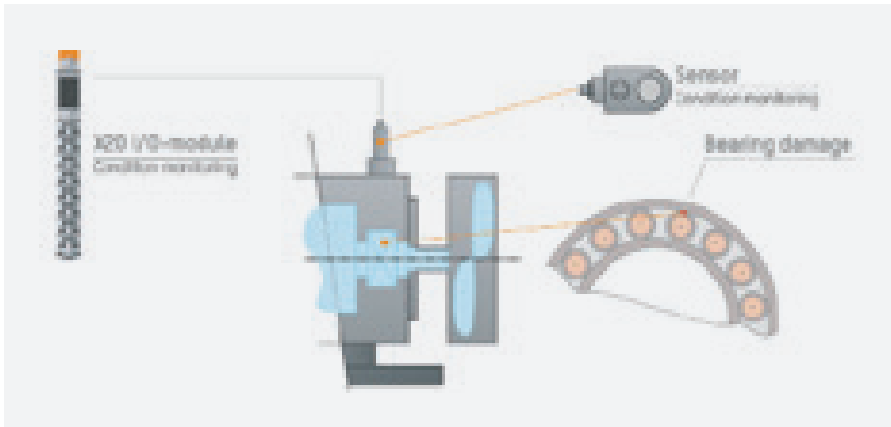

B&R's condition monitoring modules pinpoint areas where service may be needed and are also extremely easy to configure.

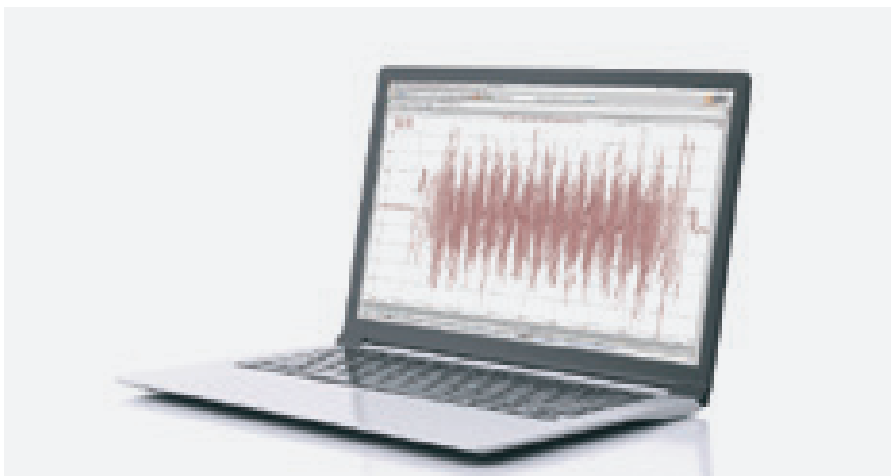

Through detailed vibration analysis of wear-prone components, it is possible to implement predictive maintenance.

mapp Technology is revolutionizing the creation of software for industrial machinery and equipment. mapp components – mapps for short – are as easy to use as a smartphone app. Rather than write lines and lines of code to build a user management system, alarm system or motion control sequence from the ground up, developers of machine software simply configure the ready-made mapps with a few clicks of the mouse. Complex algorithms are easy to manage. Programmers can focus entirely on the machine process.

Easy command of advanced control

All control functions – from a basic PID controller to a highly complex crane or hydraulics controller – are accessed via a uniform, easy-to-use interface with mapp Control. Adaptive controllers, autotuning and virtual sensing help optimize control parameters and fine tune them during operation.

gradually takes its toll on components such as hydraulic valves, which has a negative impact on the control of hydraulic axes. B&R's mapp Hydraulics package includes a software component for early detection of this type of wear. "The component automatically measures the valve's characteristic curve, which describes the relationship between valve opening and oil flow rate," explains Staudecker. "Not only does that let us know when there is wear, it also optimizes control performance."

Heating current monitoring

Particularly with highly complex machines like those in the plastics industry, the quality of the finished product relies on perfect execution of each step in the process. One subprocess typically involved in plastics production is extrusion. A faulty heating element in an extruder could bring down an entire production line, causing large amounts of waste and immense costs. "Using software components from B&R to implement predictive maintenance helps keep the machine in optimal condition and maximizes the long-term productivity of the entire system," says Staudecker. B&R's mapp Temperature package compares heating currents against reference values at freely configurable intervals. This makes it easy to notice changes in the heating circuit that indicate the first signs of damage in heating elements or relays.

New business models

Predictive maintenance also opens up potential new business models for machine builders, particularly in the area of service. By using machine data collected over a longer periods of time, for example, it is possible to more precisely forecast maintenance cycles. Machine builders can offer their customers custom tailored service that keeps machines in the field in optimal condition at all times. "The data can also be used to optimize the design of the machine itself," says Staudecker. With predictive maintenance, machine builders can offer a comprehensive service package while at the same time making effectively targeted improvements to their machines. ←

B&R products speak OPC UA over TSN



B&R is among the first manufacturers to launch a comprehensive portfolio for communication using the open, real-time capable OPC UA over TSN protocol.

B&R enables vendor-agnostic communication from sensor to cloud.



B&R is among the first manufacturers to launch a comprehensive portfolio for communication using the open, real-time capable OPC UA over TSN protocol. With high-performance X20 PLCs, bus controllers, industrial PCs and a TSN machine switch, B&R enables fully standardized networks for modular, adaptive machines. Truly economical batch-size-one production is now a re-

ality. With a standardized OPC UA over TSN network, the days when OEMs had to offer an array of machine variants with different control and bus systems are over. From a multitude of interfaces, only a single one remains – an interface that exchanges standardized data between all the nodes in the network. Machinery and plants become substantially easier to develop and operate.

More room for innovation

Configuration of OPC UA over TSN devices and the network itself, as well as assignment of access rights, is all handled in B&R's Automation Studio engineering software. Not only does that allow the configuration to take place automatically, the ready-made software blocks also minimize the amount of programming involved in developing modular machines.

You can connect drives, controllers and other devices from different manufacturers without any additional overhead. Rather than writing code, all that remains for the developer to do is set a few parameters.

18x faster

OPC UA over TSN networks are capable of plug-and-produce operation and are easy to configure and administer. Network stations will communicate up to 18 times faster than with any previously available protocol. Together with the new B&R products, this opens up new possibilities in areas such as tightly synchronized motion and control applications.

The fusion of IT and OT

OPC UA enables seamless, transparent communication from the sensor to the cloud. The TSN extension enables the protocol to converge IT and OT into a unified network, fulfilling a key requirement of all Industrial IoT applications. The technology supports networks comprising tens of thousands of nodes and benefits from bandwidth extensions to the Ethernet standard. Even large volumes of data – such as those used for intelligent condition monitoring and predictive maintenance – can be handled with ease. ←

OPC UA over TSN implementation



B&R is expanding its portfolio with a TSN machine switch for converged real-time networks with vendor-agnostic OPC UA over TSN communication.

B&R introduces TSN machine switch for converged real-time networks



B&R has added a real-time Ethernet switch to its portfolio. The new machine switch can be used to set up networks using the vendor-agnostic communication solution OPC UA over TSN. Its design and form factor fit perfectly into the B&R portfolio for space-saving mounting in the control cabinet. The TSN machine switch allows cycle times under 50 μ s. It offers four real-time capable TSN ports and one standard Ethernet port – to connect a display, for example. The switch also opens

up the possibility of star, tree or ring topologies in addition to daisy-chaining. Multiple switches can be cascaded in order to reach remote cabinets or implement large, complex real-time networks. Non-TSN nodes can also be incorporated in the network via the switch. Implementing modular machine concepts is now faster and easier than ever.

Automatic configuration

The switch is completely integrated in B&R's

Automation Studio engineering environment. Configuration occurs automatically. The device fully supports a centralized approach to hardware and software management. Application development and machine-specific configurations can be performed either offline or online. The TSN switch can also be used as a conventional unmanaged switch for non-real-time networks. No special configuration is required.

Compact design

Since the TSN machine switch is designed in the X20 form factor, it takes up minimal space in the control cabinet, mounted right alongside the X20 control and I/O system. The switch can be mounted in two different positions, depending on the cable outlet. This allows it to be installed in tight spaces. ←

Industrial IoT

Digitalization - A pressing matter

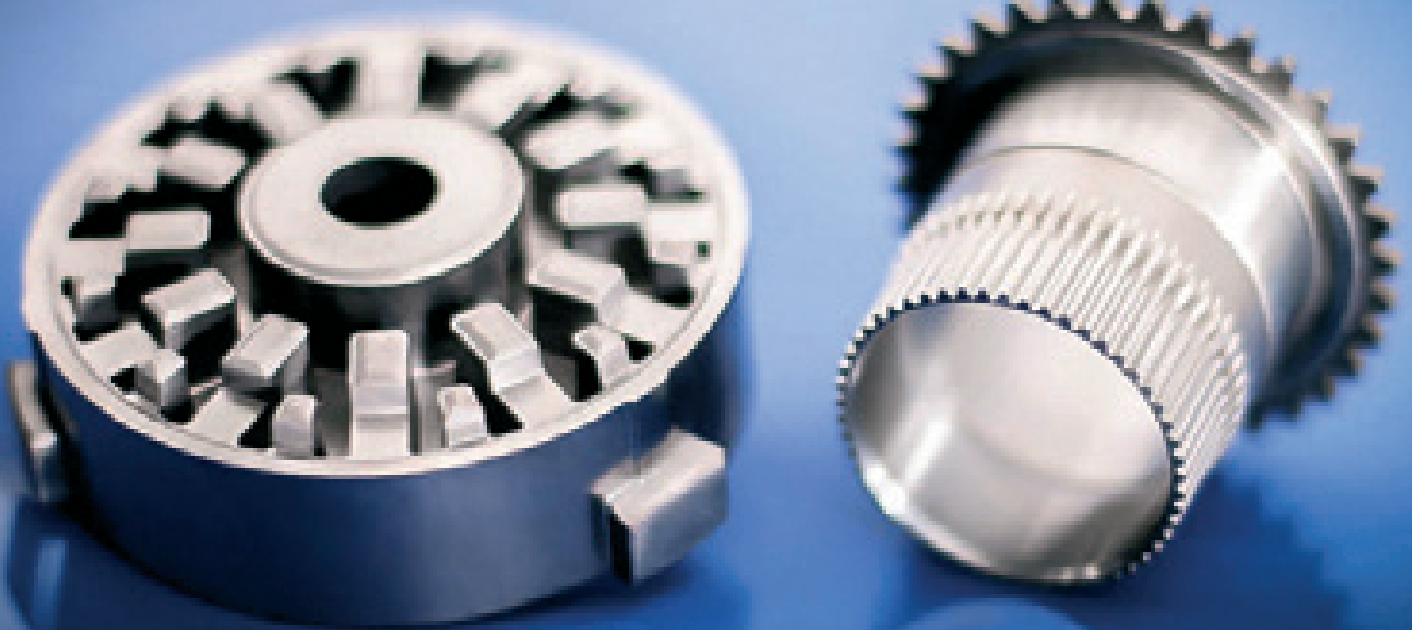

Dorst presses are used by numerous automotive suppliers to manufacture high-precision transmission and engine parts as well as other safety-relevant components.

Photo: DORST

Everyone's talking about big data, some have implemented systems to collect it, but few are utilizing the full potential of the data generated by their machines and processes. With its electric and hydraulic presses for precise forming of ceramics and metal powder, Dorst uses B&R technology to offer its customers particularly easy access to this treasure trove of information. Customers who equip their machines for intelligent maintenance can choose which data is collected and who has access to it.



Time and again, a production batch will contain a few bad apples that don't meet the buyer's quality requirements and result in the entire delivery being rejected. This can be as bad for the supplier's reputation as it is for their bottom line. Dorst Technologies, Bavaria-based manufacturer of presses and plants for the forming of metallic or ceramic powders and granulates, is dedicated to ensuring that this doesn't happen to its customers.

A powder press with added value

The key word is digitalization. As early as 2016, the 150-year-old company established a digitalization department – positioning itself as a pioneer of Germany's Industry 4.0 movement. This move served two objectives. On the one hand, the new department was tasked with examining and evaluating internal processes that had evolved over decades, including production logistics and the manufacturing processes themselves. On the other hand, they were to identify potential for digitalization and new services that would be attractive and valuable to Dorst customers.

Digitalization is still new territory for both machine builders and operators, and hard evidence of specific benefits hard to come by in the early phases of implementation. Persuading customers to take a leap of faith with the initial investment can therefore be a challenge. "It quickly became clear that whatever solution we offered would have to generate noticeable added value for our

customers as early as possible," says Director of Information Technology Herbert Gröbl, who heads the digitalization team and with nearly 30 years at the company knows Dorst better than most. "The best way to do that is to give them access to their untapped reservoir of machine and process data in manageable steps and with clearly defined objectives."

Efficient access to big data

Gröbl and his team were looking for a software solution that would enable them to do this with minimal cost and effort, yet maximum security and flexibility. The first place they turned was to the big-name software giants. "These companies were offering very advanced IoT platforms with many of the features we had in mind. However, these were typically closed systems with enormous price tags. On top of that, there was a generally lack of experience when it came to bridging the gap between the machine and the software," notes Gröbl.

After initial discussions, Dorst turned down a custom solution from a software company. "As software specialists, there's no question they know their stuff," Gröbl concedes.

"The problem was that we would have had to spell out every detail of every step along the way. And in the end, we would have had a partner at our side that, at least internationally, was largely an unknown." That's a deal breaker for many customers, so the

search for a more out-of-the-box solution continued. Dorst has been using B&R products for many years, so it made sense to have a look at the automation specialist's APROL software – already well-established in the areas of process and factory automation – and test its suitability as a digitalization platform.

"It didn't take long for us to realize that APROL would be the way to go. The platform already had almost everything we needed," Gröbl recalls. "And so, soon after implementation began in 2017, we already had our first tangible results." His team was supported by APROL experts from B&R and its long-standing Qualified Partner, Megasystems. The solution arrived at through this joint development is exceptionally modular, open and scalable and meets the latest security standards.

No impact on existing assets

B&R offers a variety of communication interfaces that make it possible to tap into data generated by many types of machine and plant controllers. Dorst chose a different route, however. To rule out any risk of impacting existing systems in a way that would make it necessary to revalidate them, Dorst equips its presses with a second controller, identical to the machine controller, that couples out the machine and process data. This also makes it possible to connect additional sensors without having to modify the primary machine controller.



Dorst builds hydraulic and electric presses for forming granulates and powders, which are in high demand among leading manufacturers all around the world. Seen here: a servo press of type EP12, which can position the upper punch and die with a precision of ± 0.001 mm.

"All the data collected in this way is exclusively the property of the user," says Gröbl. They can build their own IoT solution around it, or hook it up to an existing MES system – as long they have the IT and database expertise these approaches require. For those that don't have this expertise in-house, Dorst created two levels of more in-depth solutions.

With Dorst's intermediate-level solution, data is collected on an edge controller located on site at the user. This data collector consists of a B&R industrial PC, on which an

APROL runtime version is installed that requires only a one-time licensing fee. This PC is able to collect data from multiple Dorst presses. Should the processing or connectivity requirements evolve, it's no problem to switch to a more powerful industrial PC from the B&R portfolio.

APROL offers various containers for storing data. It's a simple matter of configuration to define which data goes into which container. This makes it possible to separate process data from machine data and handle each in different ways. The APROL system configura-

tion doesn't require any expertise in database management, and allows Dorst to offer transparent traceability of the flow of data.

Flexible data preparation and custom reporting

Data supplied by the machine controllers can be checked and pre-processed on the edge controller. This reduces the volume of data that needs to be handled in subsequent steps by filtering out only what is relevant and validated. It is also possible to only record certain data when triggered by an event such as an alarm, error or stoppage. Data from multiple processing steps at different times can also be mapped to a specific part number. This makes it possible, for example, to link the amount of force exerted during pressing to a subsequent measurement of the same part.

The broad spectrum of ready-made processing functions offered by the B&R software platform makes it possible to implement seamless documentation of all machine and process data with a remarkably small amount of actual programming. Dorst used a counter function, for example, to set up a sort of "odometer" that keeps track of the cumulative load applied by the hydraulic cylinders that drive the tools. Based on this information, users can draw conclusions about the remaining service life of these important and very expensive components. The counter function is also applied across multiple machines to track the total number of rejected parts.

This data is stored in an integrated database and can be retrieved via OPC UA by higher-level systems such as the customer's MES system. "An aspect that is particularly important to us is the openness of the APROL system, which in this case allows us to transfer data from the internal APROL da-



Herbert Gröbl
Director of Information Technology, Dorst Technologies

“Using B&R’s proven software, we have developed a flexible, future-ready IoT platform that helps us to deliver clear added value to our customers right away. This provides optimal support in their efforts to seamlessly document and optimize their manufacturing processes.”

tabase to a MariaDB database,” says Gröbl. “This ensures that our users can easily access the data via JDBC or ODBC, or even set up their own reporting tools.”

Smart maintenance

With its most comprehensive solution, Dorst offers its customers even more advanced services based on user-generated data. Data that has been authorized by the user can be sent to a central logging server via the same router used for remote maintenance of the machines. “There are NDAs and data usage agreements that clearly define what data we are permitted to view,” notes Gröbl. The necessary cybersecurity is provided by a VPN connection over the Internet, additionally secured by certificates that ensure compliance with even the stringent security requirements of the process manufacturing industry. The logging server does not require a continuous connection to the routers. Instead, data is stored intermediately on the edge controller and retrieved at regular intervals, ensuring that the services are unimpaired by temporary network interruptions.

“The data we receive is processed and then interpreted by our machine experts, who are able to do things like estimate the remaining service life of hydraulic pumps by looking at the amount of oil leakage. That’s what we call smart maintenance,” says Gröbl. “We’re also working on an automated predictive maintenance systems based on deep learning algorithms.”

Both live and processed data can be visualized clearly and intuitively in the sophisticated dashboards of APROL’s DisplayCenter. Reports can be embedded directly via an HTML call or made available to the customer on their edge controller. The JasperReports software included with APROL enables Dorst

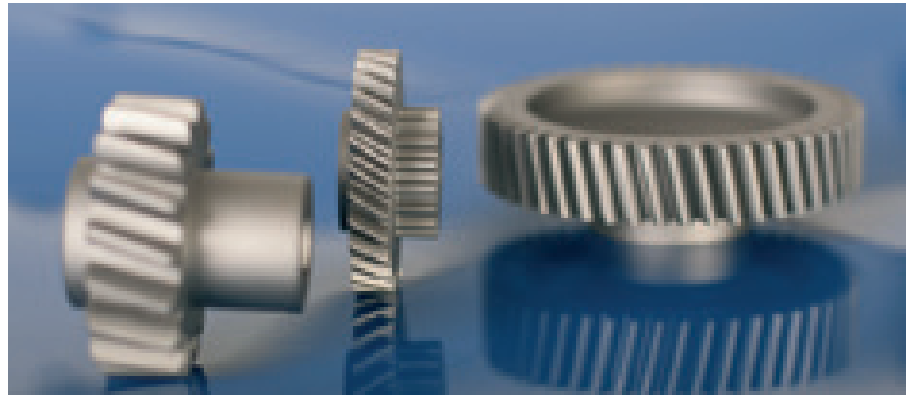

Manufacturers of automotive components are increasingly required to implement quality assurance measures that record, document and process data for each part they produce. Dorst has developed an APROL-based IoT platform for this purpose.



The IoT solution from Dorst allows customers to record and store process and machine data and generate reports that provide an at-a-glance overview of the condition and efficiency of their production presses.

to provide its customers reports that are perfectly tailored to their needs and preferences. The machine builder has also added a standard reporting tool based on the MariaDB database, further expanding the reporting options available to users.

“These features go to show how, using B&R’s proven software, we have developed a flexible, future-ready IoT platform that helps us

deliver clear added value to our customers right away. This provides optimal support in their efforts to seamlessly document and optimize their manufacturing processes,” summarizes Gröbl. “The full potential of the platform is far from exhausted, however. We’re currently working with customers on advanced functions and services that will further increase the efficiency and availability of their manufacturing systems.” ←

Digital twins

Virtual meets reality

When you rush through the construction of a new machine without thorough testing, you risk letting fundamental flaws in the design go unnoticed until commissioning. At that point, any changes to the finished machine are extremely costly and time consuming. That's why a growing number of machine builders are using simulated models – digital twins – to test and implement new machine designs quickly and cost effectively.

Wearing VR or AR headsets, machine developers can interact directly with their model, free of distractions.

Photo: BSR



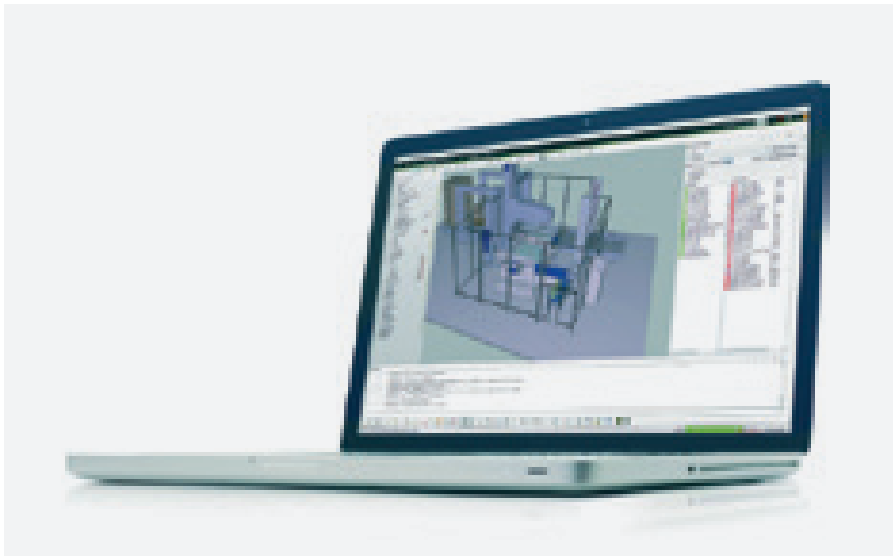

The 3D simulation software industrialPhysics uses CAD data to create a digital twin. The developer simply imports this data in STEP format, and can then quickly and easily create a digital twin.



When designing a new machine, one of an OEM's primary concerns is getting it built and on the market as quickly as possible. Delays, complications and failed prototypes can quickly threaten a project's economic viability. Conventional approaches to machine development and deployment are no longer up to the task. That's where digital twins come into play. A digital twin accompanies a machine throughout its entire lifecycle – from

conceptual planning to after sales service. Parallel to the real machine, it is developed, adapted, improved and tested. Any design flaws or necessary changes are brought to light through simulation before going to the expense of building a physical prototype.

Simulating production processes

In addition to simulating the machine's hardware and software, the digital twin

must also provide a realistic real-time representation of production processes. Simulating the movement of products on a conveyor belt, for example, helps identify potential collisions early on. "A simulation tool needs to visualize high-speed processes in conjunction with the real controller," notes Kurt Zehetleitner, R&D team leader for simulation and digital twin technology at B&R. "So, in addition to being very powerful, it must also offer real-time capability." These are two criteria that industrialPhysics satisfies perfectly. With an integrated real-time physics engine, the software simulates dynamic machine behavior in 3D. All the dynamic forces that impact the flow of materials can be tested using the digital twin. The machine developer gets instant visual feedback about how behavior is affected by different combinations of machine components. Unnecessary downtime can also be quickly identified and eliminated.

Importing CAD data

industrialPhysics generates digital twins using the machine's CAD data. The developer simply imports this data in STEP format, and can then quickly and easily create a digital twin. The digital twin can then be used to test how different kinematic arrangements, component configurations and code changes will affect the machine. B&R has integrated industrialPhysics into its Automation Studio engineering environment. "The direct link between the simulation tool and Automation Studio means that developers are able to run the virtual model of the machine right on the PC – in a hardware-in-the-loop or software-in-the-loop configuration – and connect with the controller," says Zehetleitner.

Virtual reality

In order for developers to interact directly with the simulated machine without outside distractions, the model needs to be avail-



Kurt Zehetleitner
R&D Team Leader – Simulation and Digital Twin, B&R

"industrialPhysics is based on a high-precision, real-time capable physics engine, which enables realistic simulation of production processes in real time."

able in three dimensions. industrialPhysics offers the option of viewing the digital twin in a virtual reality or augmented reality headset. The developer can experience the planned machine in three-dimensional space – and with simulated movements even in four dimensions. “With a VR headset, the developer can evaluate production processes with the simulation running. It’s also possible to connect to a real controller or test handling,” says Zehetleitner. Unlike a VR headset, an AR headset superimposes the digital twin over the machine’s real environment. This makes it possible to test what-if scenarios when planning and developing machines with moving objects. Information can be obtained from the controller in real time and viewed along with the simulation. The VR and AR systems can easily be integrated in the software in a matter of minutes. industrialPhysics simulation models are then displayed directly in the VR or AR headset rather than on the PC screen.

Virtual commissioning

After a machine’s hardware and software have been developed and the production processes have been tested, it is time for virtual commissioning. Thanks to the digital twin, the commissioning process can be repeated over and over until everything is working optimally. Only when things go perfectly smoothly in virtual commissioning is the first physical prototype built. “Virtual commissioning is extremely inexpensive compared to the real thing. So you use the digital twin to eliminate as many errors as possible and run through as many prototype iterations as necessary before building and commissioning the real machine,” explains Zehetleitner. That has a positive impact on the return on investment.

Digital doppelgänger in the control cabinet

The benefits of a digital twin don’t end with commissioning, however. The connected

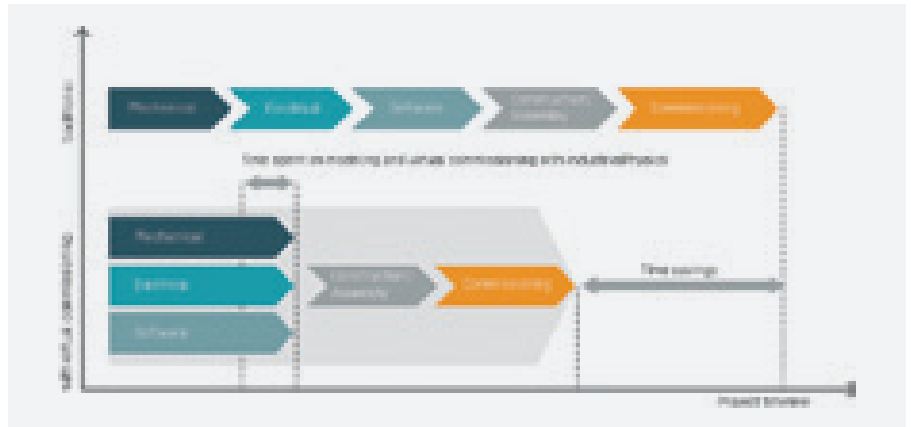

The digital twin is developed, adapted, improved and tested right along with the actual machine. This helps bring design flaws, inconsistencies or necessary changes to light at an early stage.

Digital twin as a service

To support customers who wish to create a digital twin, B&R offers a special service package. B&R developers build a complex model of the machine using existing CAD data – a quick and cost-effective way to get development projects off to a smooth start. In B&R’s engineering tool, Automation Studio, the digital twin is used for initial verification and integration testing. The entire development project becomes instantly more predictable and efficient to manage. The digital twin is also immediately available to be used for communication within the individual development teams.

factories of the Industrial IoT generate and process enormous volumes of operating data. A digital twin can put this data to good use. “Supplied with the machine’s real-time data, the digital twin runs like a virtual copy of the machine in the control cabinet,” explains Zehetleitner. If the behavior of the real machine deviates from that of the digital twin – because of a worn out bearing, for example – the difference is detected immediately. The collected data can be used for

predictive maintenance, fault reporting or remote maintenance systems.

A digital twin also helps when it comes time to upgrade or expand the machine. Insight gained during operation can be fed back into the development process. The machine builder is able to use the simulation model to test the planned modifications. This minimizes the amount of time the machine needs to be down to implement the changes. ←

Getting serious about serialization

Counterfeit medicine is a growing challenge for today's pharmaceutical industry. Patients in the European Union are protected by Falsified Medicines Directive 2011/62/EU, which places mandatory serialization and verification requirements on medicinal packaging. To comply, packaging lines need special equipment to print and verify 2D product codes, like the Pharma 2D from Intrex. Equipped with modular automation hardware and software from B&R, the new machines can be quickly adapted to on-site requirements.



For more than a quarter century, Intrex has made a name for itself creating proprietary solutions for marking, labeling, printing and vision control, with customers in nearly every industry. Recognizing the pharmaceutical market's demand for a new serialization and labeling machine, they designed the new Pharma 2D Light and Pharma 2D Pro.

Individual requirements vs. Restrictive standards

While solving the individual requirements of its pharmaceutical customers, Intrex would also have to ensure that the new machines meet the industry's restrictive standards and guidelines. A prime example is the FDA 21 CFR Part 11 regulation stipulating documentation and tamper-proofing requirements for all electronically stored data. For the operator interface, this means guaranteeing certain functions, such as alarm management, audit trail and user account management. The variety of different technologies in the machine – from motion control to serialization – meant the control system would have to provide a high level of flexibility, openness and integration. "We've had very positive experiences using B&R automation systems in our other machines," says Automation Manager Mariusz Wojciechowski, "so they were the first place we turned with the requirements of this new project." Intrex was pleased to find that the scalability of B&R's solutions made it possible to use a substantial portion of the software already used in their traditional labelling systems.

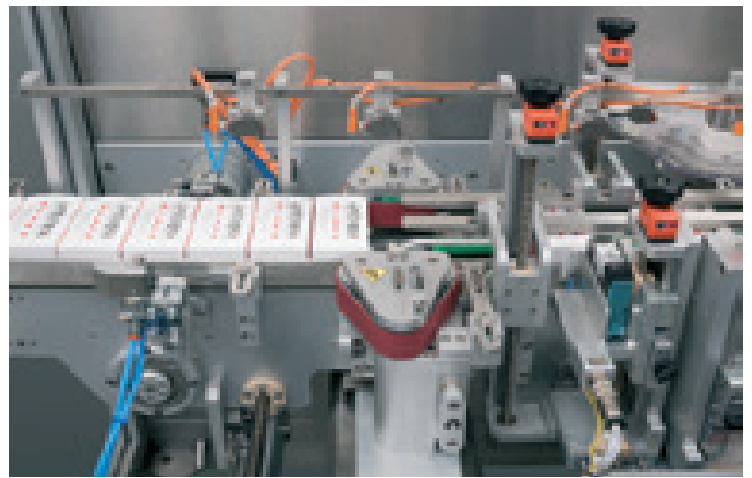
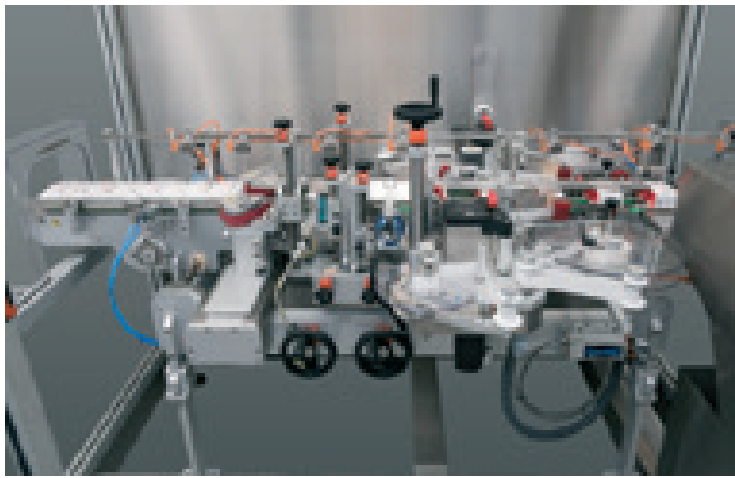

B&R drive technology ensures synchronized movements for precise label application.

Scalable hardware

The automation hardware is based on a modular X20 control system with a powerful PLC. The system can be easily expanded with I/O modules as the need arises, and its three-part design allows for easy hot-swapping of modules during operation.

The machine conveys the product and applies self-adhesive labels, so electric drives are an important part of the system. Frequency inverters, servo drives and servo motors from B&R ensure that the labeling heads are tightly synchronized with the moving products. Stepper controllers are used for standard applications, while more dynamic applications with labelling speeds up to 100 m/min use compact servo drives. Both versions of the head drives are based on the ACOPOSmicro family, so the software is identical and only the speed parameters need to be adapted. The main fieldbus network is POWERLINK, which provides convenient wiring and minimum cycle times for efficient communication. In addition, the controller must be able to communicate openly with other devices such as printers, a vision-based verification system or a dedicated serialization system, via a variety of interfaces.

Advanced pharma functions out of the box

B&R's modular mapp Technology gave Intrex ready-to-use software components specially designed for implementation of FDA 21 CFR Part 11 requirements. With the mapp User component, for example, they were able to quickly set up a system to manage user accounts, access rights and passwords. The mapp Audit component makes it possible to record events that occur on the machine. Any attempts to gain unauthorized access or change system parameters are logged, archived and can be presented in various forms. PDF reports can be stored locally on the device, on a server, or sent to a specified email address. "The ability to use these ready-made components compliant with FDA 21 CFR Part 11



Modern serialization for the pharmaceutical industry: Intrex Pharma 2D Pro.



Mariusz Wojciechowski
Automation Manager, Intrex

"B&R's mapp Technology made it quick and easy to implement the software functions we needed to comply with FDA 21 CFR Part 11."

Photos: Intrex, B&R



The swing-arm mounted touchscreen panel provides convenient, intuitive operation.

significantly reduced the time it took us to complete the project,” reports Wojciechowski. “Comparable solutions on the market are usually very expensive, while developing one in house from scratch would involve a huge amount of work and be burdened with a significant risk of error.” The ability to use off-the-shelf automation hardware compatible with solutions used in simpler Intrex machines further contributed to the fast implementation.

Full range of benefits

Thanks to the versatile communication capabilities of Pharma 2D machines, they can be operated either as standalone units or as an integral part of a packaging line. It is also possible to use the description of modes and machine operating states defined in the PackML standard, making it easy to exchange data with other devices in the line from other manufacturers.

The machine’s software makes it possible to trace the box with the product at any moment along its journey. The motion control solutions deliver high precision product transport, which translates into reduced waste and high quality printing, reading and verification. Replacing a component – whether a controller, drive or panel – is as simple as connecting the new device. After the next start-up, the system will recognize the device and send it the program and parameters it needs. Pharma 2D is a complete solution for serialization of pharmaceutical products, enabling printing of high-quality 2D codes, alphanumeric markings, vision control and security labelling. The machines are made according to Good Manufacturing Practice (GMP) quality assurance guidelines.

B&R’s scalable control system and modular software make it easy to adapt the machine to the needs of the factory where it will be installed – allowing INTREX to provide its customers the highest quality solution in the shortest possible time. ←



B&R mapp Technology gives Intrex a ready-made set of modular software components.

You can check out the video here:



Pharma 2D Light



Pharma 2D Pro

For more information:
www.intrex.pl

Industrial IoT

Easily in touch with your machines



Photo: BSR

Traditionally, once an OEM sells a machine, they are perfectly content to never hear from the buyer again – because that means the machine is running. How smoothly it is running is another question altogether. Beyond the occasional spare part or scheduled maintenance, contact with the customer – and any prospect of additional revenue – ends at delivery. That is all about to change, however.



Through digitalization, the Industrial Internet of Things (IIoT) and cloud applications, it is now possible to monitor machines in the field and evaluate their performance. For machine builders, these newfound capabilities open up exciting new possibilities. If they can analyze the productivity, energy consumption and key performance indicators of the machines they have sold, what they want to know is whether they can use all this knowledge to offer new services and establish new business models. For IoT experts, the answer to this question is a resounding “yes”. That is precisely what becomes possible when you have access to comprehensive data about the state of a machine.

Analyzing machine behavior

If they want to become more responsive to their customers’ needs, machine builders need a connection to their machines in the field. “That’s the only way they can analyze the machines’ behavior and



The cloud application collects machine data around the clock and displays it in a clearly organized dashboard.

know how well they are running,” explains B&R’s IIoT expert, René Blaschke. Despite overwhelming arguments in favor of a cloud solution, machine manufacturers still tend to be skeptical of the matter. One question they frequently ask is: “What does a cloud solution offer that I can’t get through remote access? Blaschke has a simple answer: “Remote access only shows you what can be seen on the machine’s HMI screen. What a cloud solution can do is much deeper and more significant: it can provide information about the condition and performance of the machine. The countless possibilities that this opens up are now available to B&R customers in the form of its first cloud application, Asset Performance Monitor. Asset Performance Monitor collects machine data around

the clock, prepares it and displays it in a clearly organized dashboard. It makes it easy for OEMs to keep track of their machines – anytime, and anywhere. “The cloud application provides them with a global view of their entire machine fleet,” says Blaschke. For the first time, they have detailed evaluations of how their machines are faring in the field. “When machine builders are able to see the production rates, energy consumption and key performance indicators of their machines, they can select and compare the data for a given machine type across their entire installed base. This allows them to identify weaknesses and make targeted improvements to the machine,” says Blaschke. The knowledge obtained from the data analyses can also be used to develop more efficient machines.

New business models

Well-targeted machine improvements are just one way to exploit the obtained data, however. Asset Performance Monitor also offers machine builders the ability to implement new business models. Blaschke names service level agreements and customized maintenance service as two examples. “Since they have access to data from their entire fleet, machine builders are able to offer their buyers custom-tailored service. For example, they can adapt the service interval based on how heavily the machine is actually being used.”

Machine builders can also offer upgrades for entire machines or specific functions as a service to their customers. They can offer



René Blaschke
Product Manager for Industrial IoT, B&R

“Asset Performance Monitor provides machine builders with a global view of their entire machine fleet.”

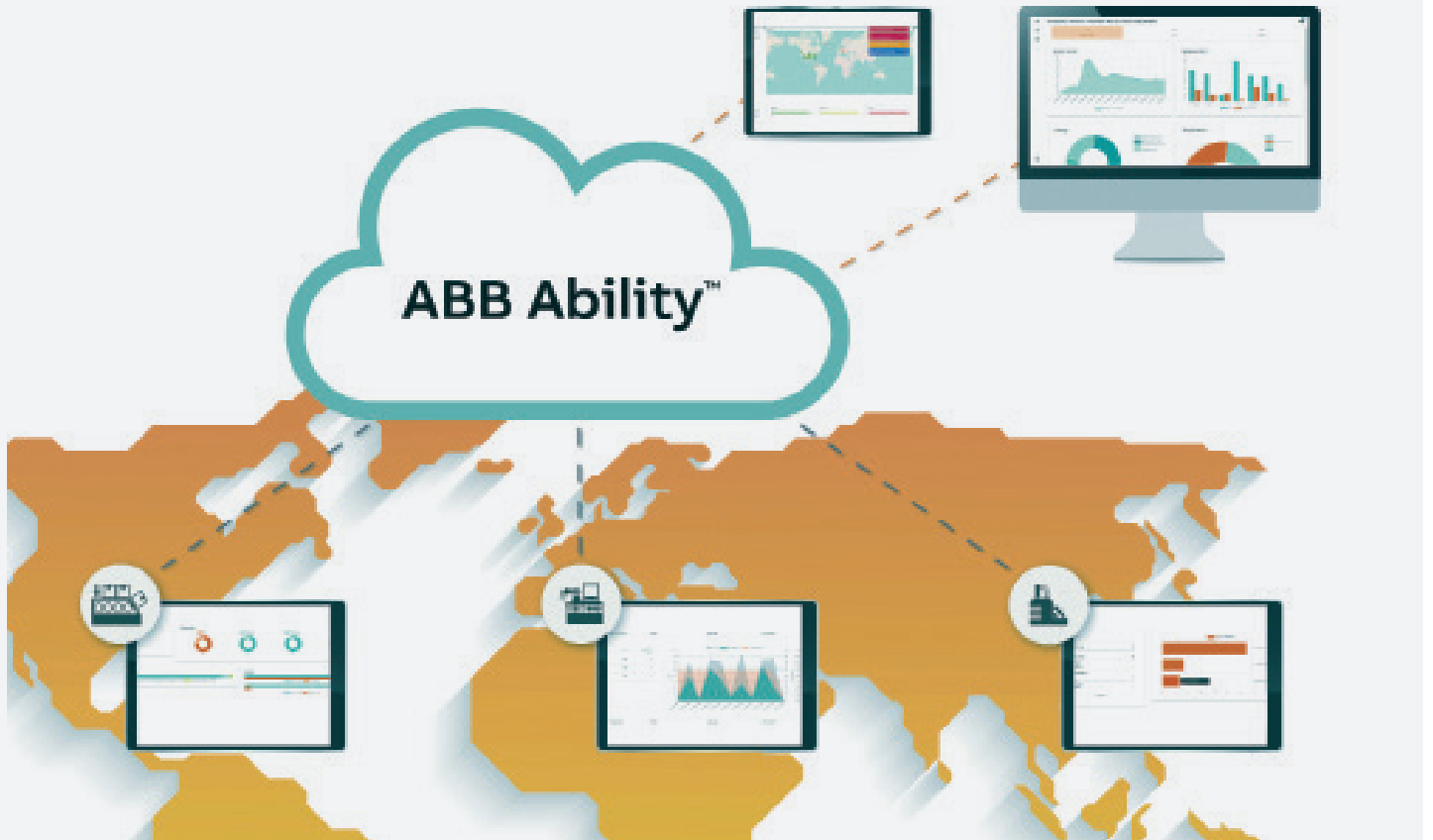

B&R's cloud application is based on the ABB Ability platform – the unified, cross-industry digital offering from B&R's parent company ABB.

new and improved services in the area of energy and condition monitoring, including processing consumption data and displaying alarms. With B&R's mapp Technology, machine builders no longer need to develop and constantly maintain these functions in house. All they have to do is implement and configure the ready-made mapp software components.

A strong team behind the scenes

The cloud solution is based on the ABB Ability platform – the unified, cross-industry digital offering from B&R's parent company ABB. Microsoft Azure functions as the infrastructure for the ABB Ability platform. It ensures reliable access to all ABB Ability services around the world. The main benefit to OEMs of having these strong partners in the background is the peace of mind. As Blaschke says: "The system is fully scalable, so it doesn't matter whether the machine builder has five machines in the field or a thousand.

Local data regulations, such as the General Data Protection Regulation (GDPR) in Europe, can be integrated into the B&R solution because the ABB platform takes these legal requirements into account. "Only the latest encryption algorithms, protocols and technologies are used for data security," Blaschke affirms. The IoT engineers of the ABB Ability platform are responsible for ensuring that it is always state of the art. "To achieve the same type of security in-house, machine builders would have to make consid-

erable investments. With Asset Performance Monitor, they receive a ready-to-use solution that guarantees the security and integrity of their data," says Blaschke.

Open architecture

In order for the cloud application to collect machine data, the machine or production line must be connected to an edge gateway, such as an Automation PC. It receives data from the machine controller via OPC UA and passes it on to the cloud using the MQTT protocol. The edge gateway automatically establishes a connection to the ABB Ability cloud and installs the necessary software. "With Asset Performance Monitor, we have created an out-of-the-box solution," emphasizes B&R's IoT expert. Simply logging in with a username and password gives the OEM access to Asset Performance Monitor and all the features it has to offer.

A win-win situation

Machine builders and operators both stand to benefit from a cloud solution that is fed with the corresponding data. "With a cloud solution, the machine builder is finally able to approach the end customer proactively after the machine has been sold," says Blaschke. Asset Performance Monitor is also multi-client capable. This makes it possible to limit the data that individual users are permitted to see. Machine builders can resell the system to their customers, allowing them to learn more about the machines they are using: The after-sale dialog can begin. ←

Secure remote maintenance

Fault response in minutes, not days

By eliminating the need for physical access to field devices, a VPN-based remote assistance service reduces a specialist machine builder's fault response times from days to minutes. For Maximator, a secure remote monitoring and maintenance package from BSR has helped reduce on-site visits, made commissioning more efficient and improved response times for troubleshooting its high-pressure hydraulic and pneumatic systems.





SiteManager is a small, secure, Internet-enabled modem that connects the machine in the field, via the installed PLC, to the Internet and the GateManager server.



Maximator is among the world's leading manufacturers and suppliers of pumps and boosters, valves, fittings and tubing for high-pressure gas and fluids. Its UK subsidiary also assembles these components into specialized testing, pressure and control systems. With a long history relying on B&R for automation technology, Maximator also turned to B&R when it came time to select a remote maintenance solution. Secure Remote Maintenance now allows Maximator UK to remotely access its installed base of machines and view customer HMI systems in

order to support and guide them through production tasks or to provide programming and troubleshooting of software. Before Secure Remote Maintenance, Maximator UK's engineers would need to travel extensively to customer sites so they could witness first-hand how they were interacting with the machine, provide support during commissioning or fix faulty configurations. Furthermore, once the machine is operational, customers often want to add functionality to further automate their process, such as when they discover a production bottleneck

or a repetitive task must be performed. This often entails writing software. Maximator UK's engineers can now remotely access the machine and update the software, saving both time and money. "Now, if a customer has a production challenge, they simply call us and we can connect and help them solve the problem within minutes," says Maximator UK's managing director, Jon Butler. "That is a huge benefit to the customer as they do not have to schedule in a technician to go to the site. Alternatively, our engineers can proactively alert end users to any upcoming service or maintenance issues of which they may otherwise be unaware."

Secure package

There are three components to the Secure Remote Maintenance package. SiteManager is a small, secure, Internet-enabled modem that connects the machine in the field, via the installed PLC, to the Internet and the GateManager server. It only has to be installed once, and if it becomes necessary to replace the device, all parameters are transferred from the machine controller to the new SiteManager. It is available in three variants for different Internet connections: LAN, WLAN or mobile network modem (LTE/4G/3G/GPRS). GateManager is the service that then connects all the various SiteManagers to each other. GateManager checks access rights before establishing the connection between technician and machine via B&R's server. User accounts, authorization settings and machines are all managed using an intuitive web portal that can be customized to the specific requirements of the customer. GateManager can be leased from B&R as an SaaS (Software as a Service) solution or installed on an in-house server.

LinkManager is a software client used by the service technician to establish a connection to the machine. Users can remotely view live information from the PLC via dashboards or HMIs and make changes to coding without having to travel to the customer site. It runs on Windows XP/7/8/10 for maximum compatibility, while LinkManager Mobile allows technicians to access machines and systems using a smartphone or tablet for diagnostics and reporting.

Easy added value

"What impressed us is the ease with which the Secure Remote Maintenance system can be set up and activated on a machine," says Butler. "It really is out-of-the-box and plug-and-play." Some Maximator UK machines feature a system that sends emails every month requesting that customers take hourly or cycle count readings. For some customers this can be burdensome.

Using GateManager, Maximator UK is able to remotely take the cycle count readings and

instantly spot if there are any problematic trends. "Customers are very receptive to that level of service," says Butler. "We see it as a great added value to our products, and we don't even need to charge extra for it, as it not only saves us money by avoiding site trips to resolve minor issues, but also enables us to provide a better product to our customers."

Security about security

Maximator UK had been considering the potential for remote assistance for over two years. Eventually, its rapidly growing installed base and increasing awareness and acceptance among its customers of Industry 4.0 indicated that the timing was right. "It is proving harder and harder for us to make the number of site visits that would be needed to look after our installed base," says Butler. Now, Maximator can view the relevant data remotely and immediately implement the necessary updates, amendments or fixes. "The key motivator has been our customers' realization of the power of

Industry 4.0 and the ease with which we can safely and securely connect in a cost-efficient and effective way."

VPN networks, firewalls and certificate-based authentication ensure maximum security for the remote connection. Protection is even provided against man-in-the-middle and denial-of-service (DoS/DDoS) attacks. In order to avoid conflicts with plant firewalls, communication between the SiteManager and the Internet is handled using firewall-compatible encrypted web protocols.

"If customers do have security concerns, we offer 3G or 4G alternatives, meaning that we avoid interfacing with their network," says Butler. "And we give them a switch on their machine so they can turn off the device at any time so that we are unable to connect without their consent. The connection is only ever made in response to the customer's request for service or maintenance." ←



Jon Butler
Managing Director,
Maximator UK

"The key motivator has been our customers' realization of the power Industry 4.0 and the ease with which can safely and securely connect in a cost-efficient and effective way."



The LinkManager Mobile application allows technicians to access machines and systems using a smartphone or tablet.

The power of a PC



B&R's X20CP3687X controller combines the performance of an industrial PC with the compact design of the X20 controller series.

B&R's industrial controllers take performance to a whole new level.



The new B&R X20CP3687X controller combines the performance of an industrial PC with the compact design of the X20 controller series. With powerful processing, additional RAM and integrated onboard flash memory, the high-performance controller can handle complex control algo-

rithms or even robotics applications that previously would have called for an industrial PC. With a TSN-enabled Ethernet interface, the X20CP3687X is well-equipped for the future. It is fully prepared for communication using the manufacturer-independent communication standard OPC UA over

TSN. The controller comes standard with connections for USB and POWERLINK. Additional interfaces can be added via interface modules. Despite its powerful capabilities, the new module has exactly the same design and dimensions as all the other controllers in B&R's X20 series. ←

Photo: B&R

Austria's largest self-consumption PV system



With a capacity of 1.5 megawatts, B&R's rooftop photovoltaic system is currently the largest self-consumption station in Austria.

B&R expands photovoltaic system to 1.5 megawatts



Automation specialist B&R has expanded its photovoltaic system and increased its capacity from one megawatt to 1.5 megawatts. The roof of the company's headquarters in Eggelsberg is now home to Austria's largest solar power system for self-consumption*. B&R uses sustainable solar power in its own manufacturing facilities.

B&R put the first part of the photovoltaic system into operation in May 2018. With the expansion, the plant now provides 1,500 MWh of climate-neutral solar energy per year. That's enough to power the homes of

around 430 families for a year. The electricity the company generates is fed directly into its manufacturing facilities where it is used to operate numerous production lines. The photovoltaic system is installed on the rooftops of the B&R production halls and covers an area of around 12,000 m².

Contribution to sustainability

"We are proud to now have the largest self-consumption PV system in Austria and thus make our contribution to sustainability and environmental protection," says B&R Managing Director Hans Wimmer. The state

government of Upper Austria supported the expansion of the plant. "Subsidies like this make it easier for companies to contribute to environmental protection. We are very grateful for the support," says Wimmer.

Making industry more sustainable

B&R's parent company ABB is involved in the Mission to Zero initiative for ending reliance on fossil fuel. ABB contributes to industrial sustainability through its products and services. More than half of ABB's revenue comes from technologies that combat the causes of climate change. ←



Smart factory

Automated with a human touch

Asked to imagine a digital factory, we likely picture a sterile shop floor entirely devoid of human operators. In their absence, artificially intelligent machines orchestrate every aspect of production with complete autonomy. In this case, however, the difference between imagination and reality is substantial. Digitized and connected as the smart factory may be, there remain many ways that it still relies on a human touch.

B&R production workers are already supported by an array of assistance systems, including digital work instructions, training videos and pick-by-light guidance.

Photo: B&R



Industry 4.0 is all about connectivity throughout a company's entire value chain. Connected machines, products, systems and people allow processes to be executed with almost complete automation. Humans and machines operate hand in hand. For this cooperation to not only work, but work efficiently and profitably, both sides must be perfectly coordinated. The connected value chain should increase productivity, while at the same time improving the workplace experience. By taking over monotonous tasks, for example, automated processes and machines free up employees to focus on more demanding activities that make better use of their skills and potential.



PC production at B&R demonstrates the advantages of the digital factory. Advanced workstation assistance systems allow employees to assemble any PC after brief training – with up to 250 billion different configuration options.

Connected

At automation specialist B&R's headquarters in Eggelsberg, Austria, Industry 4.0 has been the name of the game for more than a decade – and the number of employees has been growing steadily all along. B&R's 40,000 m² smart factory is fully connected – both horizontally and vertically. This is made possible by an ERP system that optimizes the order processing schedule and ensures that the logistics run smoothly.

Workplace of the future

B&R has partnered with Upper Austria's University of Applied Sciences to develop the "human centered workplace for industry", or in other words: the factory of the future. Through the project, B&R hopes to provide even better support for its production employees and to improve the human-machine collaborative experience. The university is analyzing the current working environment and building a prototype workplace of the future in the lab. This allows them to test, for example, how workstations can be improved through new technology, such as augmented reality glasses.

Digitalization is the spice of life

B&R already has numerous worker-assistance systems in use. These are especially helpful in the production of industrial PCs. They make it possible to assign employees flexibly to a diverse

range of tasks, while at the same time ensuring optimal quality. "Our PC production perfectly demonstrates the advantages of the digital factory," says B&R COO Robert Perperschlager, "After only brief training on a specific workstation, B&R employees are able to assemble any PC – despite there being up to 250 billion different configuration possibilities." With the factory of the future project, B&R is currently testing additional assistance systems. "Collaborative robots are playing an increasingly important role," explains Perperschlager, "giving employees a convenient 'third hand' when handling complex parts."



Robert Perperschlager
COO, B&R

"Industry 4.0 has been the name of the game at B&R for more than a decade now – and the number of employees has been growing steadily all along. The B&R smart factory has around 40,000 m² of production space and is fully connected both horizontally and vertically."



B&R is currently evaluating a new system that will inform maintenance and repair technicians in the event of an impending machine failure.



The smartwatch provides maintenance staff with improved workplace safety. Rather than being interrupted by phone calls, they simply twist their wrist to glance at the display.

Digital instructions for each step

One of the solutions currently under evaluation would replace conventional displays with projections directly onto the workstation. The displays show the employee the work instructions for each step in the assembly process. "The great diversity of our PC portfolio makes it necessary to support our employees with work instructions. These are short sequences of images that explain precisely how the particular step is to be carried out," says Perperschlager. Once the step has been completed, it must be confirmed in the system. B&R is testing the use of touchpoints to make this process more intuitive by adapting it to the employee's natural movements. The touchpoints can be attached to the employee's clothing, such as on a sleeve or glove, where they can quickly be touched to confirm the completion of each step. This simplifies feedback to the system considerably and eliminates unnecessary interruptions.

Smartwatch notifications

B&R is currently evaluating a new system that will support maintenance and repair technicians in their daily work. "In the event of an impending fault on one of B&R's production machines, a responsible employee would immediately receive notification on the smartwatch. This way, they can react quickly from wherever they happen to be within the B&R complex," explains Perperschlager. The system

detects impending machine failures, sends this information to the ERP system, searches a database to determine which employee is qualified for the repair and displays the message on their smartwatch. There is no need for anyone to try reaching them by phone.

The smart maintenance system also prioritizes the incoming messages according to urgency. Notification of an imminent machine failure would be given the highest priority, while upcoming repairs that do not pose a threat to ongoing operation would be given the lowest priority. The smartwatch also vibrates with varying intensity depending on the level of urgency. When an event of the highest priority occurs, they know instantly without even having to look. They can drop whatever they are doing and immediately rush to the site of the incident.

Improved workplace safety

The smartwatch also provides maintenance staff with improved workplace safety. Until now, they would always have to take at least one hand away from what they are doing to take a phone call. "With the smartwatch, they've always got both hands free," says Perperschlager. "A slight twist of the wrist is all it takes to glance at the display." The notification remains onscreen until it has been seen and confirmed. Important repairs can be completed calmly before reading the message. ←

Joining together to save CO₂

As part of their efforts to reduce CO₂ emissions, car manufacturers are building vehicle bodies from lightweight materials such as aluminum and carbon composites, combined with high-strength and ultra-high-strength steel. To solve the challenging task of joining these different materials together, EJOT developed and patented the new EJOWELD process, implemented using B&R technology.



The spot welding process performed in car body construction is very demanding. The strength of the joint and the achievable cycle time are subject to the same demands as for welded joints. In addition, there are a whole range of technological conditions that must be precisely adhered to and documented for the different combinations of materials. On top of that, the robot-guided tool must be able to reach all the required locations on the body without any collisions.

High-precision friction welding

At first glance, the friction welding process used in the EJOWELD solution appears to be relatively simple. A setting tool presses and rotates a connecting element through the softer outer material in a four-stage process, and the resulting friction heats it up to approximately 1,100°C, permanently joining it with the harder layer below. The devil is in the details, however. For starters, the whole process takes only between 0.7 and 1.8 seconds. "If you don't ad-



EJOT has 545 employees at its production site in Tambach-Dietharz, Germany.

here to the process parameters very precisely," Schrodtt explains, "the connection won't hold, and before long the layers will begin to separate." To monitor the process and store the results for quality assurance, up to 30,000 data points are logged during each welding process. "That's quite a demanding task for the control system," says Robert Heiland, who leads EJOWELD development. "BSR's Automation PC, ACOPOSmulti and POWERLINK technology do an outstanding job mastering the challenge."

Equipped for global use

"In order to deploy the solution anywhere in the world, the power supply for the drive technology must be independent of the mains supply. This is important to ensure consistent processing conditions without having to install different components for each type of power grid." That's exactly why BSR designed the power supply modules of its ACOPOSmulti drive system to supply the DC bus with a constant 750 VDC over a wide range of mains voltages and frequencies. The reactive power is regulated to $\cos \varphi = 1$, which is important for optimized mains power regeneration.

Drive precision ensures optimum quality

During the friction welding process, it is necessary to switch between different control processes in real time. "We have to be able to identify the moment when the friction element reaches the harder material with a precision of just a few microseconds in order to be able to switch to the corresponding control process," says Heiland. The servo drive reads the values of a separate axial force sensor and applies them highly dynamically as additional input parameters in the current control loop. Additional control

signals are incorporated from peripheral devices and must be processed in a matter of microseconds. These signals are read by BSR X67 I/O modules mounted on the setting tool in the immediate vicinity of the process, and transmitted directly to the drive and controller via POWERLINK.

Modular, interoperable hardware ensures flexibility

The greater the differences in the materials being joined, the more flexible the automation system needs to be in order to adapt to the different requirements. "With BSR, we have a partner whose products enable us to implement these adaptations perfectly and without any compatibility problems," says Heiland. The different hardware and software interfaces required for integration with the robot and other production equipment are standard features of the BSR portfolio.

Thanks to BSR's integrated safety technology, the same level of adaptability is also possible for the safety solution. Last but not least, the complete interoperability of BSR's X20 PLC and Automation PC allows EJOT to scale the solution as needed without having to make adjustments in the software application. "We can easily upgrade to a powerful industrial PC for more advanced process control," says the sales manager, giving some insight into future development plans. Another goal is to further optimize the setting tool design with even more compact motors.

In so doing, EJOT is making an important contribution to the use of lightweight materials that make automobile manufacturing more environmentally friendly. ←



A friction welding system consists of a robot arm that holds a setting tool, together with a corresponding control cabinet.



The friction welding system is operated using a B&R Mobile Panel.



The setting tool has a feed and a friction drive and is mounted on a carrier system with minimized interference contours.

Robert Heiland
EJOWELD Systems Engineer, EJOT

"Developing a whole new system generation is a momentous decision. Choosing a partner with such a well thought-out concept and comprehensive service helped us turn our vision into reality and offer a solution that is well-equipped to handle whatever new requirements the future brings."

New X20 generation for the future of automation

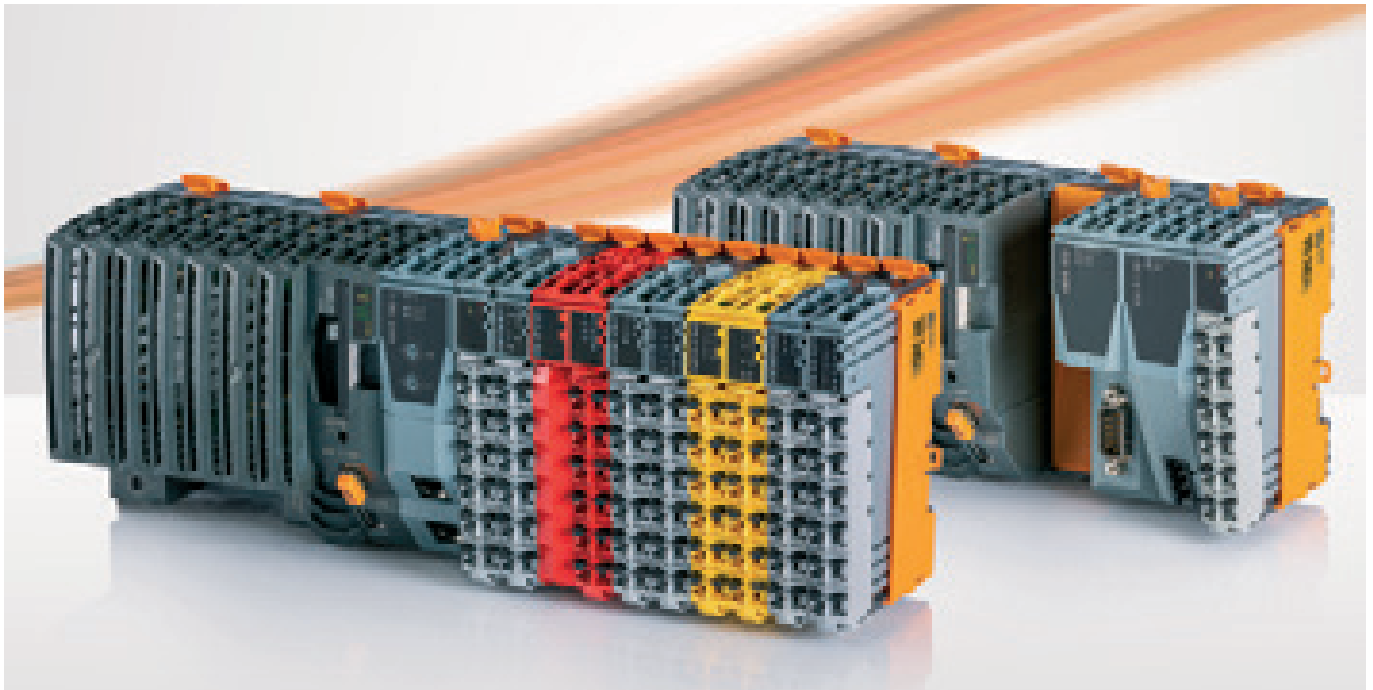

B&R is among the first manufacturers to introduce controllers with OPC UA over TSN communication technology and Intel Apollo Lake I processors.

B&R introduces new controllers with OPC UA over TSN and Intel processors



B&R is among the first manufacturers to introduce controllers with OPC UA over TSN communication technology and Intel Apollo Lake I processors. The new X20 controllers are distinguished by significantly higher performance, additional RAM and integrated onboard flash memory. The new controller generation supports OPC UA over TSN and can be used as a field-level master in corresponding networks. It offers considerably more processing power than previous

X20 generations with the same compact design. The controllers are equipped with high-speed Intel Apollo Lake I processors and enable cycle times as fast as 100 μ s. They also offer a large L2 cache, a faster floating point unit (FPU) and faster RAM access for optimal command processing.

Integrated flash memory

The new X20 controller generation has integrated flash memory. This allows them to be

optionally operated without a Compact-Flash card. In this case, the integrated flash drive replaces the functionality of the CompactFlash card.

Extreme space savings

As with all X20 controllers, up to 250 I/O modules can be connected directly to the controllers and line up seamlessly. The entire system saves a large amount of space in the control cabinet. Even with its compact design, the controller has a built-in power supply for itself and the connected I/O modules. POWERLINK, TSN-enabled standard Ethernet, CAN, RS232 and USB are available as integrated interfaces. Additional interfaces can be added via interface modules. ←

Efficient production
of any batch size

NEXT GENERATION INDUSTRIAL TRANSPORT TECHNOLOGY

www.be-automation.com/transport-technology

Integrates into any process

→ Synchronizes perfectly with CMC and robotics

Field proven

→ Best-in-class reliability

Easy maintenance

→ Industrial-grade quality, service-friendly design

POWERLINK

SAFETY

BE AUTOMATION



Return address: B&R Industrial Automation GmbH, B&R Straße 1, A-5142 Eggelsberg