

ControlLogix Time Synchronization Module - Series B

Catalog Numbers 1756-TIME



Important User Information

Read this document and the documents listed in the additional resources section about installation, configuration, and operation of this equipment before you install, configure, operate, or maintain this product. Users are required to familiarize themselves with installation and wiring instructions in addition to requirements of all applicable codes, laws, and standards.

Activities including installation, adjustments, putting into service, use, assembly, disassembly, and maintenance are required to be carried out by suitably trained personnel in accordance with applicable code of practice.

If this equipment is used in a manner not specified by the manufacturer, the protection provided by the equipment may be impaired.

In no event will Rockwell Automation, Inc. be responsible or liable for indirect or consequential damages resulting from the use or application of this equipment.

The examples and diagrams in this manual are included solely for illustrative purposes. Because of the many variables and requirements associated with any particular installation, Rockwell Automation, Inc. cannot assume responsibility or liability for actual use based on the examples and diagrams.

No patent liability is assumed by Rockwell Automation, Inc. with respect to use of information, circuits, equipment, or software described in this manual.

Reproduction of the contents of this manual, in whole or in part, without written permission of Rockwell Automation, Inc., is prohibited

Throughout this manual, when necessary, we use notes to make you aware of safety considerations.



WARNING: Identifies information about practices or circumstances that can cause an explosion in a hazardous environment, which may lead to personal injury or death, property damage, or economic loss.



ATTENTION: Identifies information about practices or circumstances that can lead to personal injury or death, property damage, or economic loss. Attentions help you identify a hazard, avoid a hazard, and recognize the consequence.

IMPORTANT

Identifies information that is critical for successful application and understanding of the product.

Labels may also be on or inside the equipment to provide specific precautions.



SHOCK HAZARD: Labels may be on or inside the equipment, for example, a drive or motor, to alert people that dangerous voltage may be present.



BURN HAZARD: Labels may be on or inside the equipment, for example, a drive or motor, to alert people that surfaces may reach dangerous temperatures.



ARC FLASH HAZARD: Labels may be on or inside the equipment, for example, a motor control center, to alert people to potential Arc Flash. Arc Flash will cause severe injury or death. Wear proper Personal Protective Equipment (PPE). Follow ALL Regulatory requirements for safe work practices and for Personal Protective Equipment (PPE).

Preface	Studio 5000 Environment	5
	Additional Resources	6
	Chapter 1	
Overview	1756-TIME Module Overview	7
	Hardware	8
	GPS Antenna	9
	Software	10
	Chapter 2	
Setup	BOOTP	11
	Factory Defaults	11
	ControlFLASH Software	12
	The Logix Designer Application Configuration	12
	View the Satellite Status in the Logix Designer Application	14
	Satellite Signal	14
	Satellite Position	15
	1756-TIME Module AOP Configuration Parameters	15
	Chapter 3	
Operation	Logix5000 Controller Input Image	19
	Logix5000 Controller Output Image	23
	Web Interface	24
	Chapter 4	
Time Synchronization	1588 Precision Time Protocol (CIP Sync)	25
	1756-TIME Module as a PTP Master	26
	Configure the Ethernet Module/Controller	
	PTP/CIP Sync Settings	27
	PTP as a Time Source	29
	Network Time Protocol (NTP)	29
	1756-TIME Module as an NTP Server	29
	1756-TIME Module as an NTP Client	31
	IRIG-B	32
	1756-TIME Module as an IRIG-B Master	32
	1756-TIME Module as an IRIG-B Slave	33
	CST and UTC Time Conversion	33
	Time Synchronization Protocols	34
	NTP vs. IRIG vs. PTP	34
	Network Time Protocol (NTP)	35
	Simple Network Time Protocol (SNTP)	36
	NTP Server Choice	36
	IRIG B-122 Protocol	36
	Precision Time Protocol (PTP) – IEEE 1588-2008	37

	Example Architectures	37
	1756-TIME Module and NTP Client Functionality.....	38
1756-TIME Module Status Indicators	Appendix A	
	Status Indicators	41
	Status Messages	42
CST/UTC Conversion Message Blocks	Appendix B	
	CST to UTC and Gregorian Time Conversion	43
	UTC to Gregorian Time Conversion	43
	Satellite Information	44
Operating Modes	Appendix C	
	GPS Source	45
	IRIG-B Source	46
	PTP Source	46
	NTP Source	47
GPS Antenna Cable Extensions	Appendix D	
	Cable Extensions	49
	Determine the Length of the Cable	49
	Determine the Attenuation Rate of the Cable.....	49
	Example – Determining Cable Requirements	50
	Cable Extension Kits.....	51
	Lightning Protection Devices	51
	Trimble BX982 Setup	52
	Base Station with Rover Setup	55
	Base Station Setup	55
	Rover Setup.....	56
Glossary	57

Studio 5000 Environment

The Studio 5000 Automation Engineering & Design Environment™ combines engineering and design elements into a common environment. The first element is the Studio 5000 Logix Designer™ application. The Logix Designer application is the rebranding of RSLogix™ 5000 software and will continue to be the product to program Logix5000™ controllers for discrete, process, batch, motion, safety, and drive-based solutions.



The Studio 5000® environment is the foundation for the future of Rockwell Automation® engineering design tools and capabilities. The Studio 5000 environment is the one place for design engineers to develop all of the elements of their control system.

Additional Resources

These documents contain additional information concerning related products from Rockwell Automation.

Resource	Description
ControlLogix Time Synchronization Module Installation Instructions, publication 1756-IN049	This document provides installation information and specifications for the 1756-TIME time synchronization module.
Integrated Architecture and CIP Sync Configuration Application Technique, publication IA-AT003	This document explains CIP sync technology and how you can synchronize clocks within the Rockwell Automation Integrated Architecture.
ControlLogix System User Manual, publication 1756-UM001	Describes the necessary tasks to install, configure, program, and operate a ControlLogix system.
EtherNet/IP Network Configuration User Manual, publication ENET-UM001	Provides Bootstrap Protocol/ Dynamic Host Configuration Protocol (BOOTP/DHCP) information for setting the IP address of the module.
ControlFLASH® Firmware Upgrade Software User Manual, publication 1756-UM105	Describes the necessary tasks to install, and use the ControlFLASH software to update the module firmware.
Industrial Automation Wiring and Grounding Guidelines, publication 1770-4.1	Provides general guidelines for installing a Rockwell Automation industrial system.
Product Certifications website, http://www.ab.com	Provides declarations of conformity, certificates, and other certification details.

You can view or download publications at <http://www.rockwellautomation.com/literature/>. To order paper copies of technical documentation, contact your local Allen-Bradley distributor or Rockwell Automation sales representative.

Overview

Topic	Page
Hardware	8
GPS Antenna	9
Software	10

1756-TIME Module Overview

This user manual describes the functionality, installation, configuration, and operation of the 1756-TIME module, series B, firmware revision 3.001.

The 1756-TIME module provides accurate time synchronization on different interfaces by using Global Positioning System (GPS) technology. The 1756-TIME module obtains time from various sources, and provides time synchronization on other devices by acting as a gateway between different time synchronization methods and standards.

Time synchronization is accomplished by using these methods, standards, and protocols:

- The ControlLogix® backplane for Coordinated System Time (CST) and Coordinated Universal Time (UTC) conversion.
- Inter-range Instrumentation Group, code B (IRIG-B) standards.
- Precision Time Protocol (PTP) on Ethernet and the ControlLogix® backplane.
- Network Time Protocol (NTP) on Ethernet.

The 1756-TIME module provides GPS position in the form of latitude, longitude, and altitude (LLA).

The 1756-TIME module provides course and route information in the form of ground speed (knots) with heading in the form of degrees from true north.

Hardware

The 1756-TIME module operates within the ControlLogix platform. All power that is required for the operation of the module is supplied by the ControlLogix backplane.

The K in the a catalog number 1756-TIMEK, indicates that the module has the conformal coating option.

For more information about the conformal coating option, see [Conformal Coating on page 33](#).

Figure 1 - 1756-TIME Module, Front View

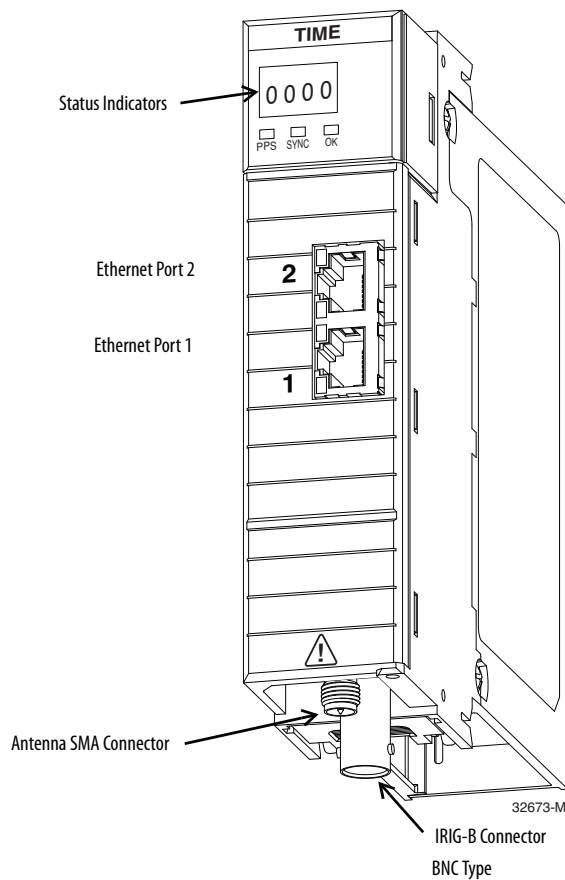

Table 1 - 1756-TIME Module Hardware Descriptions

Hardware	Description
Status indicators and messages	Provides status and operational information for the 1756-TIME module. See 1756-TIME Module Status Indicators on page 41 .
Ethernet connector 1 and Ethernet connector 2 (uses Rockwell Automation® dual-port switch technology)	PTP and NTP time synchronization uses the Ethernet connections. Note: This connection is not a bridge to the backplane and cannot be used to view modules on the backplane.
Antenna SMA connector	Connect the GPS bullet antenna to this connector. See GPS Antenna on page 9 .
IRIG-B BNC type connector	Connect the IRIG-B network cable to this connector. The 1756-TIME module can be configured as a master clock or a slave clock on the IRIG-B network.

GPS Antenna

The GPS antenna is connected to the module via an SMA connector. Install the GPS bullet antenna with a clear view of the sky (nothing to obstruct the view of the antenna to the sky).



Do not install the antenna where objects can obstruct the view of the antenna to the sky. If an antenna is installed with a limited view of the sky, the GPS receiver can either experience a low satellite lock count or not be able to obtain a lock at all. A limited view of the sky can cause inaccurate time synchronization.

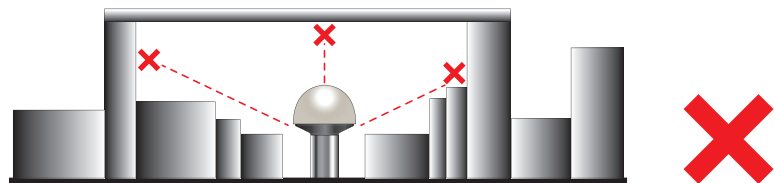
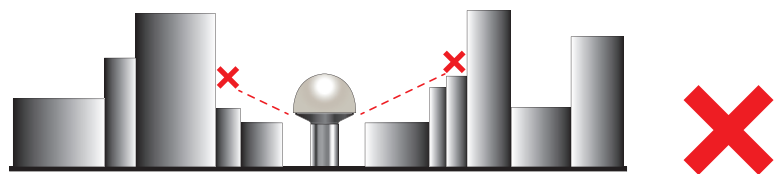
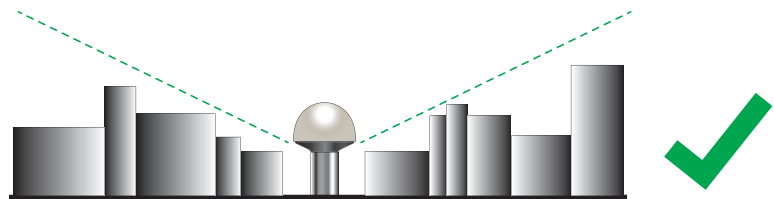

32660-M

Software

Use this software to configure and operate the 1756-TIME module:

- The Studio 5000 Logix Designer® application
- The Add-on Profile (AOP) for the 1756-TIME module, available for download at this link:

<http://www.ab.com>.

Setup

Topic	Page
BOOTP	11
Factory Defaults	11
ControlFLASH Software	12
The Logix Designer Application Configuration	12
View the Satellite Status in the Logix Designer Application	14
1756-TIME Module AOP Configuration Parameters	15

BOOTP

Use BOOTP to set the initial IP address for the 1756-TIME module. The module comes from the factory with BOOTP enabled.

The BOOTP/DHCP server is a standalone server that you can use to set an IP address.

Access the BOOTP/DHCP server from one of these locations:

- Programs > Rockwell Software > BOOTP-DHCP Server
- Tools directory on the Studio 5000 environment installation CD

If you have not installed the BOOTP/DHCP server, you can download and install it from <http://www.ab.com/linked/networks/ethernet/bootp.html>.

To set the IP address of the module with a BOOTP/DHCP server, follow the steps that are found in EtherNet/IP Network Configuration User Manual, publication [ENET-UM001](#).

Factory Defaults

If the module fails or becomes inoperable, the module reboots with factory-loaded boot software. The display informs you of the error and suggests a method to fix the error. If there is a firmware error, use the ControlFLASH™ software to restore the module to a working condition.

ControlFLASH Software

Use the ControlFLASH software to upgrade the software to a newer version.

For more information on the ControlFLASH software and how to use it, see ControlFLASH Firmware Upgrade Software User Manual, publication [1756-UM105](#).

The latest firmware can be found at the Product Compatibility and Download Center (PCDC) <http://www.rockwellautomation.com/global/support/pcdc.page>.

The Logix Designer Application Configuration

Before you can program the 1756-TIME module, the AOP for the module must be installed. You also need admin rights for the module to view and configure the AOP.

IMPORTANT Each 1756-TIME module is programmed to work with one Logix5000™ controller.

IMPORTANT There is no direct communication between the 1756-TIME module Ethernet ports and a Logix5000 controller. If the 1756-TIME module resides in a remote Logix rack, it must communicate through an EN2T(R) module in the same rack.

Follow these steps to configure the 1756-TIME module in the Logix Designer application.

1. Double-click the 1756-HPTIME module in the I/O tree in the Logix Designer application.

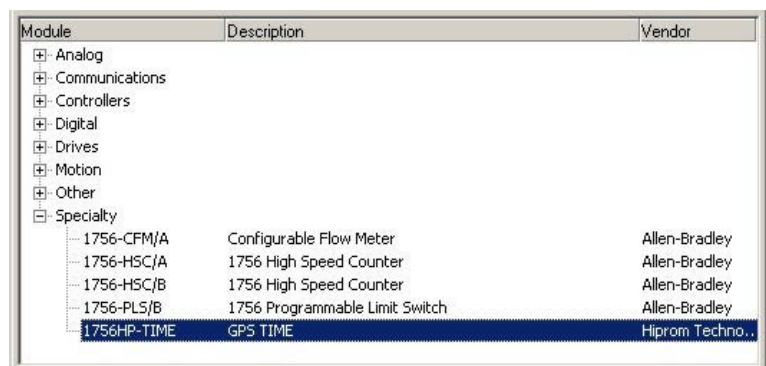

The New Module dialog box appears.

2. Enter a name for the module.
3. Enter a brief description for the module.
4. Enter the IP address for the module.

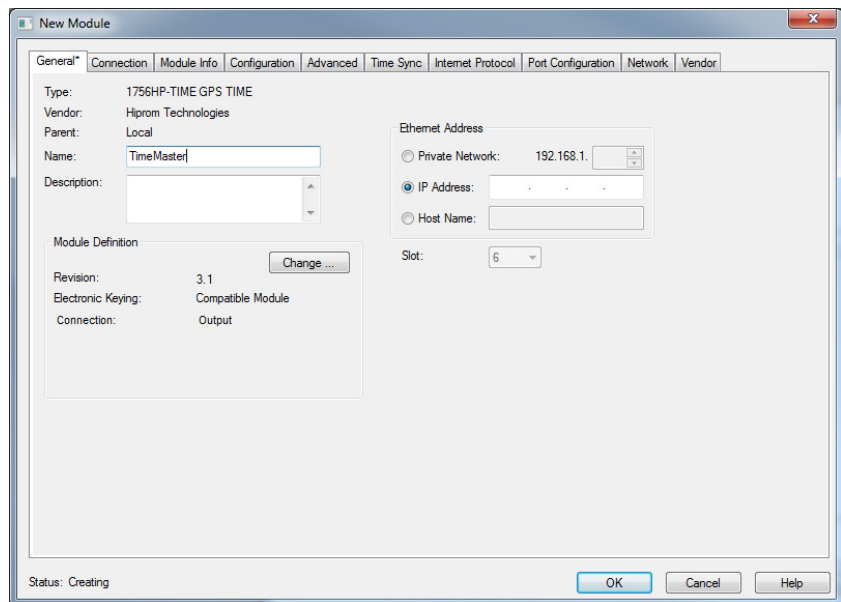

5. Click the Configuration tab.
6. From the Source Settings pull-down menu, choose the time source that you want to use.
See [Chapter 4](#) for more information on the source types.
7. Select the Time Output format.
8. Enter the Advanced CIP Sync Settings.
9. Enter the Description Settings.
10. Click OK.

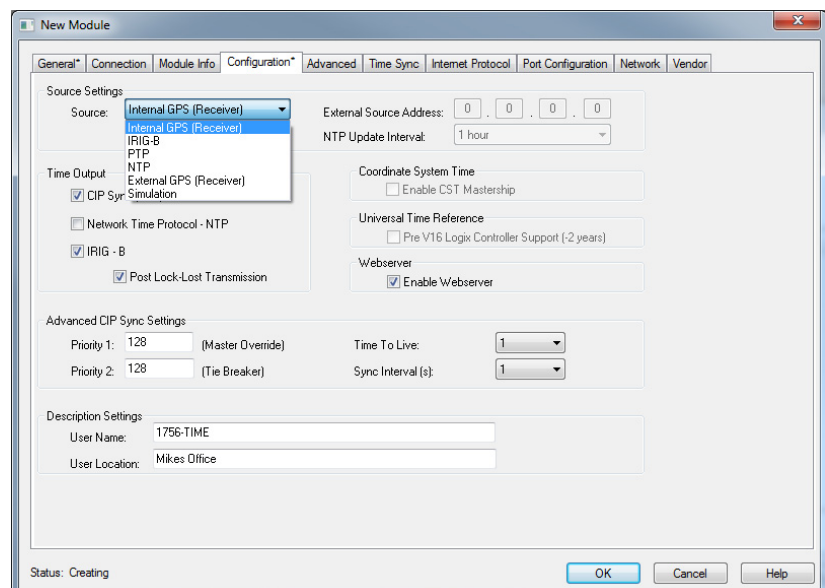

The time properties of the 1756-TIME module are now configured.

View the Satellite Status in the Logix Designer Application

Click the Advanced tab to view the source of the time (Time Input), and see if the time source is valid and available (green) or invalid (red). You can also view the output type (Time Output), the UTC time of the 1756-TIME module, and the GPS coordinates of the satellite (when a connection is locked).

Figure 2 - 1756-TIME Module Properties Dialogue Box, Advanced Tab

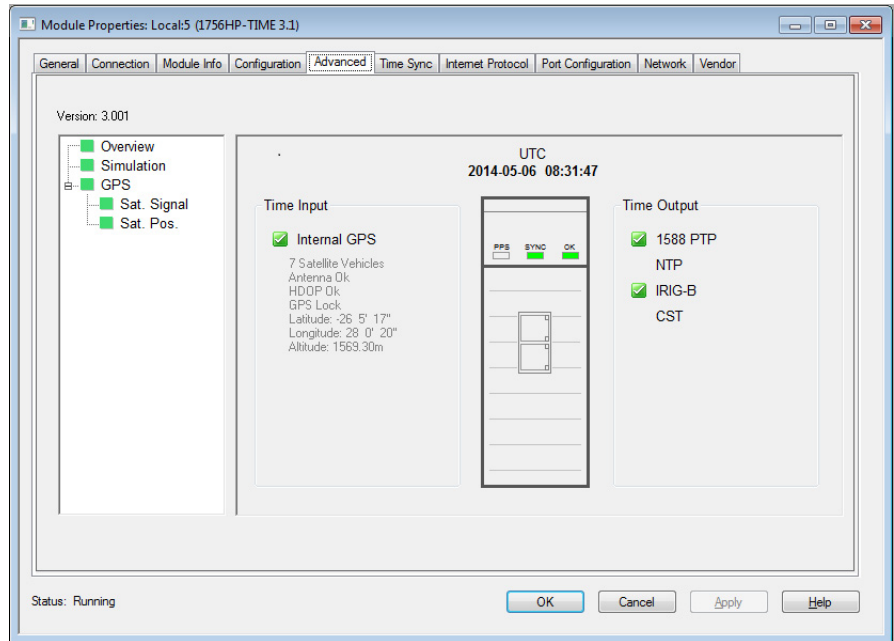

Satellite Signal

Click Sat. Signal to view the signal strength of the satellites.

Figure 3 - 1756-TIME Module Properties Dialogue Box, Sat. Signal Node

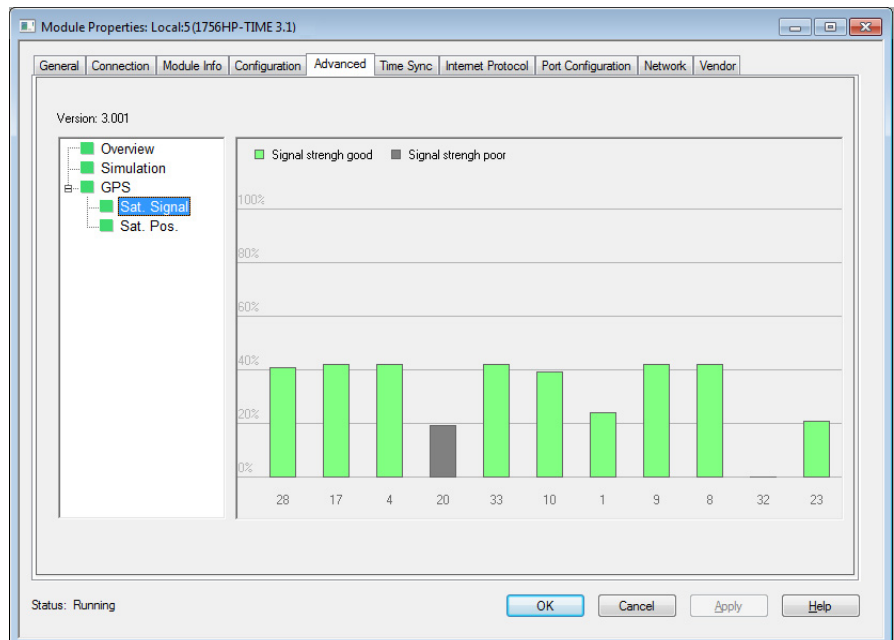

Satellite Position

Click Sat. Pos. to view the position of the satellites in the sky.

Figure 4 - 1756-TIME Module Properties Dialogue Box, Sat. Pos. Node

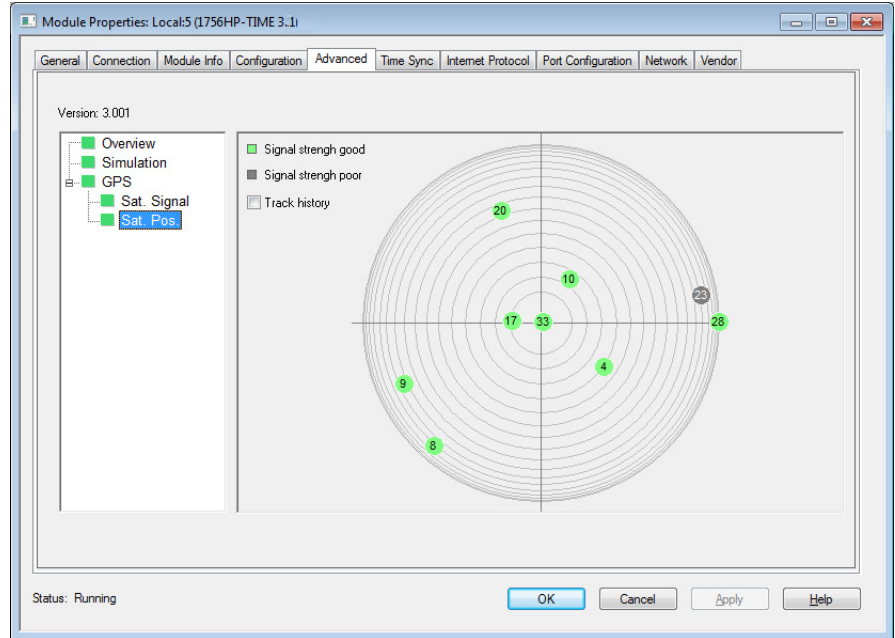

1756-TIME Module AOP Configuration Parameters

This section describes the AOP configuration parameters for the 1756-TIME module. This section is for information purposes. The AOP is used to configure the relevant module parameters.

Name	Value	Force Mask	Style	Data Type
Local:5:C	{...}	{...}		HT:1756HP_TIME_rev3:C:0
Local:5:C.Source	1		Decimal	INT
Local:5:C.Control	2#0000_000...		Binary	INT
Local:5:C.CIPSyncOutputEnable	1		Decimal	BOOL
Local:5:C.NTPOutputEnable	0		Decimal	BOOL
Local:5:C.IRIGOutputEnable	1		Decimal	BOOL
Local:5:C.IRIGLockLostTx	1		Decimal	BOOL
Local:5:C.PreV16Support	0		Decimal	BOOL
Local:5:C.CSTMastershipEnable	0		Decimal	BOOL
Local:5:C.WebsvrEnable	0		Decimal	BOOL
Local:5:C.NTPUpdateInterval	3600		Decimal	DINT
Local:5:C.ExternalSourceAddress1	0		Decimal	INT
Local:5:C.ExternalSourceAddress2	0		Decimal	INT
Local:5:C.ExternalSourceAddress3	0		Decimal	INT
Local:5:C.ExternalSourceAddress4	0		Decimal	INT
Local:5:C.Priority1	128		Decimal	INT
Local:5:C.Priority2	128		Decimal	INT
Local:5:C.CIPSyncTimeToLive	1		Decimal	INT
Local:5:C.CIPSyncInterval	0		Decimal	SINT
Local:5:C.AdvancedConfig	0		Decimal	DINT
Local:5:C.SimulationYear	2014		Decimal	INT
Local:5:C.SimulationMonth	5		Decimal	SINT
Local:5:C.SimulationDay	5		Decimal	SINT
Local:5:C.SimulationHour	13		Decimal	SINT
Local:5:C.SimulationMinute	28		Decimal	SINT
Local:5:C.SimulationSecond	0		Decimal	SINT
Local:5:C.UserName	{...}	{...}	ASCII	SINT[64]
Local:5:C.UserLocation	{...}	{...}	ASCII	SINT[64]

Table 2 - AOP Configuration Parameters

Parameter	Description	Value
Source	Indicates the time source that is used for the module.	1 = GPS 2 = IRIG-B 3 = PTP 4 = NTP 5 = External GPS (future) 6 = Simulation
CIPSyncOutputEnable	When this bit is set, the module enables 1588 PTP (CIP Sync) output.	0 = 1588 PTP (CIP Sync) output is disabled 1 = 1588 PTP (CIP Sync) output is enabled
NTPOutputEnable	When this bit is set, the module enables NTP on Ethernet.	0 = NTP v3 RF(1305) output is disabled 1 = NTP v3 RF(1305) output is enabled
IRIGBOutputEnable	When this bit is set, the module enables IRIG-B on the coaxial interface.	0 = IRIG-B-122 output is disabled 1 = IRIG-B-122 output is enabled
IRIGBLockLostTX	When this bit is set, the module keeps sending an IRIG-B signal after it has lost lock to the time source. If this bit is clear, the module stops sending a valid IRIG-B signal when it has lost lock with the time source. The module stops sending the signal as long as it has had lock at least once previously.	0 = Module stops sending IRIG-B when lock is lost 1 = Module continues sending IRIG-B, even when a lock is lost
PreV16Support	If you are using RSLogix 5000® software, version 16.00.00 and later, or the Studio 5000 environment, version 21.00.00 and later, the UTC time base is different than earlier versions of RSLogix 5000 software. The setting syncs the time between Logix5000 controllers that use any version of RSLogix 5000 software or the Studio 5000 environment.	0 = For all versions of RSLogix 5000 software or the Studio 5000 environment 1 = For RSLogix 5000 software, version 16.00.00 and earlier.
CSTMastershipEnable	Indicates if the module is the CST master clock on the local rack (if no other CST master clocks are currently active).	0 = Module does not attempt to be the CST master clock 1 = Module does attempt to be the CST master clock
WebsserverEnable	Allows you to access the web server from a web browser pointed to the IP address of the module.	0 = Module does not allow access to the web server 1 = Module allows access to the web server
NTPUpdateInterval	The time (in seconds) when the module requests an update of the time from the NTP server.	Example: 5 = 5 seconds 30 = 30 seconds 300 = 5 minutes 3600 = 1 hour 86400 = 1 day 604800 = 1 week
ExternalSourceAddress	The external source address is used for one of two sources depending on how the configuration is set: <ul style="list-style-type: none"> If the time source is set to NTP, the external source address is the IP address of the source that is used. If the source is set to External GPS, the external source address is the IP address of the GPS receiver. 	In this example, the module uses external IP address: 192.168.1.100 Byte 0 = 192 Byte 1 = 168 Byte 2 = 1 Byte 3 = 100
Priority1	Priority 1 is the override for the Best Master Clock Algorithm (BMCA).	The default is 128. Values lower than 128 indicate preference on the network.
Priority2	Priority 2 is used to break a tie between two modules with the same priority 1 value.	The default is 128. Values lower than 128 indicate preference on the network.
CIPSyncTimeToLive	Limits the lifespan of data in a network. It keeps the IP packet from circulating indefinitely.	Example: 1 = the packet circulates once
CIPSyncInterval	The time interval when the module sends out a PTP sync packet.	Allowed values: 1/2 = 500 ms 1 = 1 second 2 = 2 seconds

Table 2 - AOP Configuration Parameters (continued)

Parameter	Description	Value
AdvancedConfig	Various bits used to set certain options in the module.	Bit: 0 = Simulation Mode 1...31 = Reserved
SimulationYear	When the module is in simulation mode, use to set the initial year to be used by the module.	Example: 29 April 2014 Year = 2014
SimulationMonth	When the module is in simulation mode, use to set the initial month to be used by the module.	Example: 29 April 2014 Month = 4
SimulationDay	When the module is in simulation mode, use to set the initial day to be used by the module.	Example: 29 April 2014 Day = 29
SimulationHour	When the module is in simulation mode, use to set the initial hour to be used by the module.	Example: 11:14:23 AM Hour = 11
SimulationMinute	When the module is in simulation mode, use to set the initial minute to be used by the module.	Example: 11:14:23 AM Minute = 14
SimulationSecond	When the module is in simulation mode, use to set the initial second to be used by the module.	Example: 11:14:23 AM Second = 23
UserName	Use this parameter to identify the time module, visible in CIP Sync synchronization.	Example: 1756-TIME
UserLocation	Use this parameter to provide extra information to identify the location of the module.	Example: Basement

Notes:

Operation

Topic	Page
Logix5000 Controller Input Image	19
Logix5000 Controller Output Image	23
Web Interface	24

Logix5000 Controller Input Image

Each 1756-TIME module consumes one connection from the Logix5000™ controller. This section provides descriptions for the Logix5000 controller input image parameters.

Name	Value	Force Mask	Style	Data Type
Local:5:1	{...}	{...}		HT-1756_TIME_rev3:1:0
Local:5:1.CommStatus	0		Decimal	DINT
Local:5:1.Source	1		Decimal	DINT
Local:5:1.ModuleStatus	0		Decimal	DINT
Local:5:1.WebsvrEnabled	0		Decimal	BOOL
Local:5:1.Time	{...}	{...}		HT-1756_CLOCK_rev3:1:0
Local:5:1.Time.Status	2#0000_000...		Binary	DINT
Local:5:1.Time.Valid	1		Decimal	BOOL
Local:5:1.Time.CIPSyncOutputEnabled	1		Decimal	BOOL
Local:5:1.Time.NTPOutputEnabled	0		Decimal	BOOL
Local:5:1.Time.IRIGBOOutputEnabled	1		Decimal	BOOL
Local:5:1.Time.CSTMasteEnabled	0		Decimal	BOOL
Local:5:1.Time.CSTMasteShip	0		Decimal	BOOL
Local:5:1.Time.CSTDuplicateDetect	0		Decimal	BOOL
Local:5:1.Time.SimulationModeActive	0		Decimal	BOOL
Local:5:1.Time.Year	2014		Decimal	DINT
Local:5:1.Time.Month	5		Decimal	DINT
Local:5:1.Time.Day	6		Decimal	DINT
Local:5:1.Time.Hour	8		Decimal	DINT
Local:5:1.Time.Minute	41		Decimal	DINT
Local:5:1.Time.Second	10		Decimal	DINT
Local:5:1.Time.MicroSecond	778800		Decimal	DINT
Local:5:1.UTC	{...}	{...}	Decimal	DINT[2]
Local:5:1.CST	{...}	{...}	Decimal	DINT[2]
Local:5:1.CSTOffset	{...}	{...}	Decimal	DINT[2]
Local:5:1.GPS	{...}	{...}		HT-1756_CLOCK_rev3:1:0
Local:5:1.GPS.GPSStatus	2#0000_000...		Binary	INT
Local:5:1.GPS.GPSLock	1		Decimal	BOOL
Local:5:1.GPS.AntennaOK	1		Decimal	BOOL
Local:5:1.GPS.HDOPok	1		Decimal	BOOL
Local:5:1.GPS.PPS	0		Decimal	BOOL
Local:5:1.GPS.FaultCode	0		Decimal	INT
Local:5:1.GPS.Mode	0		Decimal	INT
Local:5:1.GPS.SVCCount	8		Decimal	INT
Local:5:1.GPS.Latitude	-26.088095		Float	REAL
Local:5:1.GPS.Longitude	28.005533		Float	REAL
Local:5:1.GPS.Altitude	1569.2		Float	REAL
Local:5:1.GPS.GroundSpeed	0.0		Float	REAL
Local:5:1.GPS.DegreeFromTrueNorth	0.0		Float	REAL
Local:5:1.GPS.MagneticVariationFromTrueNorth	0.0		Float	REAL
Local:5:1.GPS.RelativePositionX	0.0		Float	REAL
Local:5:1.GPS.RelativePositionY	0.0		Float	REAL
Local:5:1.GPS.RelativePositionZ	0.0		Float	REAL

Table 3 - Logix5000 Controller Input Image Parameters

Parameter	Description	Value
CommStatus	Reserved.	–
Source	Indicates the current time source.	1 = GPS 2 = IRIG-B 3 = PTP 4 = NTP 5 = External GPS (future) 6 = Simulation
ModuleStatus	Reserved.	–
WebserverEnable	Allows you to access the web server from a web browser pointed to the IP address of the module.	0 = Module does not allow access to the web server 1 = Module allows access to the web server
Time.TimeValid	Indicates if a valid time is being received from the time source.	0 = Time being received from source is invalid 1 = Time being received from source is valid
Time.CIPSyncOutputEnable	Indicates if the 1588 Output PTP is enabled in the configuration.	0 = 1588 PTP (CIP Sync) output is disabled 1 = 1588 PTP (CIP Sync) output is enabled
Time.NTPOutputEnable	Indicates if the NTP Output is enabled in the configuration.	0 = NTP v3 RF(1305) output is disabled 1 = NTP v3 RF(1305) output is enabled
Time.IRIGBOutputEnable	Indicates if the IRIG-B Output is enabled in the configuration.	0 = IRIG-B-122 output is disabled 1 = IRIG-B-122 output is enabled
Time.CSTMasterEnabled	Indicates if the module is enabled to be the CST master clock.	0 = Module does not attempt to be the CST master clock 1 = Module does attempt to be the CST master clock
Time.CSTMastership	Indicates if the module is the CST master clock on the local rack.	0 = Module is not the CST master clock 1 = Module is the CST master clock
Time.CSTDuplicateDetect	Indicates if the module is attempting to be the CST master clock. If there is another CST master clock on the local rack, the module sets this bit and stops attempting to be the CST master clock.	0 = There is no other CST master clock on the local rack 1 = There is another CST master clock on the local rack
Time.SimulationModeActive	Indicates if the module is operating in simulation mode.	0 = Simulation mode is inactive 1 = Simulation mode is active
Time.Year	Displays the current year that is received from the time source.	Example: 27/04/2010 13:45:22 - 234567 μ s Year = 2010
Time.Month	Displays the current month that is received from the time source.	Example: 27/04/2010 13:45:22 - 234567 μ s Month = 4
Time.Day	Displays the current day that is received from the time source.	Example: 27/04/2010 13:45:22 - 234567 μ s Day = 27
Time.Hour	Displays the current hour that is received from the time source.	Example: 27/04/2010 13:45:22 - 234567 μ s Hour = 13
Time.Minute	Displays the current minute received from the time source.	Example: 27/04/2010 13:45:22 - 234567 μ s Minute = 45

Table 3 - Logix5000 Controller Input Image Parameters (continued)

Parameter	Description	Value
Time.Second	Displays the current second received from the time source.	Example: 27/04/2010 13:45:22 - 234567 μ s Second = 22
Time.Microsecond	Displays the current microsecond received from the time source.	Example: 27/04/2010 13:45:22 - 234567 μ s Microsecond = 234567
Time.UTC	Current UTC in microseconds since the time base. The time origin is based on all versions of RSLogix 5000 [®] software or the Studio 5000 environment. See the example code for how the parameter is used to time stamp events in sequence-of-events (SOE) modules in RSLogix 5000 software versions earlier than 18.00.00.	Example: 02 April 2014 14:12:41 UTC = 87277992127872
Time.CST	Displays the current CST of the local rack (depending on the CST master clock) in microseconds.	Example: CST master clock runs for 1 hour CST = 3600000000
Time.CSTOffset	Displays the difference between the UTC and CST in microseconds. Use the parameter to set the wallclock in the Logix5000 controller in RSLogix 5000 software versions earlier than 18.00.00. Click this link to see example code: http://www.ab.com/Pages/Products/1756_CLX/1756-TIME/web/1756-TIME.htm .	Example: CSTOffset = UTC - CST UTC = 87277992127872 CST = 3600000000 CSTOffset = 87274392127872
GPS.GPSLock	Indicates if the GPS receiver has lock (if GPS is the time source).	0 = GPS receiver does not have lock 1 = GPS receiver has locked onto sufficient satellites
GPS.AntennaOK	Indicates if the GPS antenna is connected and is operational (if GPS is the time source).	0 = The antenna is either not present or is faulty 1 = The antenna is connected correctly and is operational
GPS.HDOPok	Horizontal Dilution of Precision (HDOP) occurs when there are sufficient satellites in lock, but two or more satellites occupy similar positions in the sky (therefore the number of effective satellites decreases).	0 = HDOP is active 1 = HDOP is not active
GPS.PPS	The pulse per second toggles at the exact moment the second changes and the microseconds are zero. Note: because the actual RPI is 50 ms, the accuracy is lost in the input image.	0 = It has been more than 100 ms since the rollover pulse of the last second 1 = It has been less than 100 ms since the rollover pulse of the last second
GPS.FaultCode	Reserved.	–
GPS.Mode	Reserved.	–
GPS.SVCount	Indicates the number of satellites that the GPS receiver is locked on.	A number between 0...12
GPS.Latitude	Displays the current position latitude in degrees.	Example: S26°05'17.0" E28°00'21.3" Elev: 1577 m Latitude = -26.088087
GPS.Longitude	Displays the current position longitude in degrees.	Example: S26°05'17.0" E28°00'21.3" Elev: 1577 m Longitude = 28.00586
GPS.Altitude	Displays the current position altitude in meters.	Example: S26°05'17.0" E28°00'21.3" Elev: 1577 m Elevation = 1577

Table 3 - Logix5000 Controller Input Image Parameters (continued)

Parameter	Description	Value
GPS.GroundSpeed	Displays the ground speed, in meters per second.	Example: 10.2 m/s
GPS.DegreeFromTrueNorth	Displays the degrees from true north.	Example: 279.12°
GPS.MagneticVariationFromTrueNorth	Displays the magnetic variation from true north.	Example: -18.1°
GPS.RelativePositionX	Reserved.	–
GPS.RelativePositionY	Reserved.	–
GPS.RelativePositionZ	Reserved.	–

Table 4 - GPS Mode Interpretation

Bit	Description	Interpretation
0	New position	0: No. 1: Yes
1	Clock fix calculated for current position	0: No. 1: Yes
2	Horizontal coordinates calculated this position	0: No. 1: Yes
3	Height calculated this position	0: No. 1: Yes
4	Weighted position	0: No. 1: Yes
5	Overdetermined position	0: No. 1: Yes
6	Ionosphere-free position	0: No. 1: Yes
7	Position uses filtered L1 pseudo ranges	0: No. 1: Yes
8	Differential position	0: Differential position is an autonomous or a WAAS solution. 1: Position is a differential solution.
9	Differential position method	0: Code 1: Phase including RTK, HP, or XP OmniSTAR (VBS is not derived from Phase)
10	Differential position method	0: Code (DGPS) or a float position (RTK). Uncorrected position is Autonomous (if bit 0 = 0). 1: Position is fixed integer phase position (RTK). Uncorrected position is WAAS (if bit 0 = 0)
11	OmniSTAR solution	0: Not active 1: OmniSTAR differential solution (including HP, XP, and VBS)
12	Position that is determined with static as a constraint	0: No. 1: Yes
13	Position is network RTK solution	0: No. 1: Yes
14	Position is Location RTK	0: No. 1: Yes
15	Position is Beacon DGPS	0: No. 1: Yes

Logix5000 Controller Output Image

This section provides descriptions for the Logix5000 controller output image parameters.

[-] Local:8:0	{...}	{...}		HT:1756_TIME:0:0
[+] Local:8:0.IRIGYear	0		Decimal	INT
[+] Local:8:0.UTC_Offset	0		Decimal	INT
[-] Local:8:0.ReferencePositionX	0.0		Float	REAL
[-] Local:8:0.ReferencePositionY	0.0		Float	REAL
[-] Local:8:0.ReferencePositionZ	0.0		Float	REAL

Table 5 - Logix5000 Controller Output Image Parameters

Parameter	Description	Value
IRIGYear	When the module has an IRIG-B time source, the year is not passed over IRIG-B. Enter the current year here in the output image.	Example: 30 April 2014 IRIGYear = 2014
UTC_Offset	The UTC_Offset is used only when the time source is IRIG-B, and PTP output is enabled. IRIG-B provides the UTC time, while PTP requires International Atomic Time (TAI). The difference between the two is the UTC offset.	Example: 30 April 2014 UTC_Offset = 35 Be sure to verify the current UTC offset. The UTC offset changes approximately every 18 months.
ReferencePositionX	Reserved. The reference position variables help to give increased accuracy to the RelativePosition input image tags; as the calculations are performed in the Time module using floating point math, to remove any rounding errors. The formula to calculate is as follows: $GPS.RelativePositionX = PositionX \text{ (from Ext GPS)} - ReferencePositionX \text{ (from Output Image)}$.	- See Example code for use and implementation
ReferencePositionY	Reserved. $GPS.RelativePositionY = PositionY \text{ (from Ext GPS)} - ReferencePositionY \text{ (from Output Image)}$.	See Example code for use and implementation
ReferencePositionZ	Reserved. $GPS.RelativePositionZ = PositionZ \text{ (from Ext GPS)} - ReferencePositionZ \text{ (from Output Image)}$.	See Example code for use and implementation

Web Interface

The web interface is disabled by default. Follow these steps to enable the web interface.

1. On the configuration tab, check Enable Webserver.
2. Click OK.

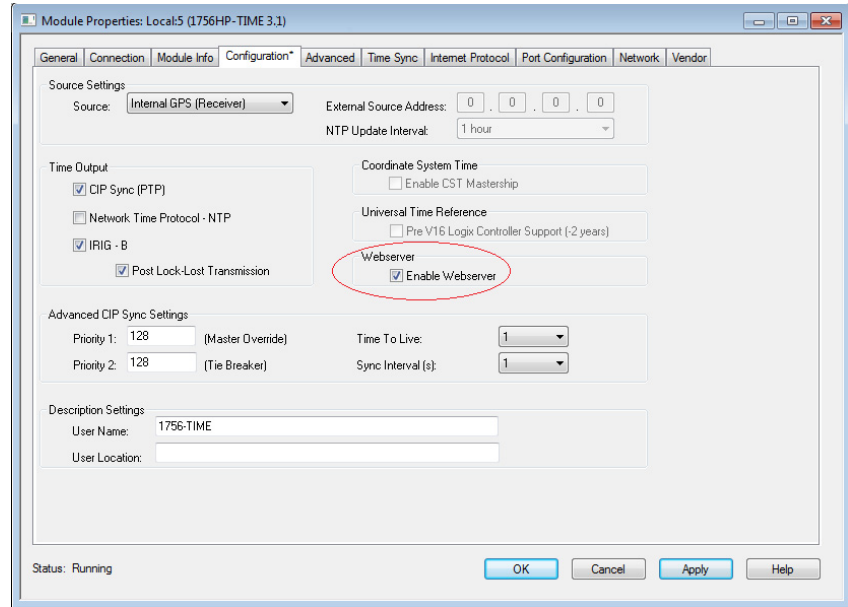

You can access the web interface from any computer that has a web browser.

Enter **http://** and the IP address of the 1756-TIME module into the address bar of your web browser.

For example, enter the IP address as shown here.

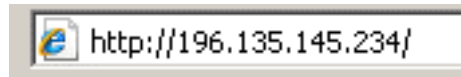

The web interface provides diagnostics and statistics for the 1756-TIME module.

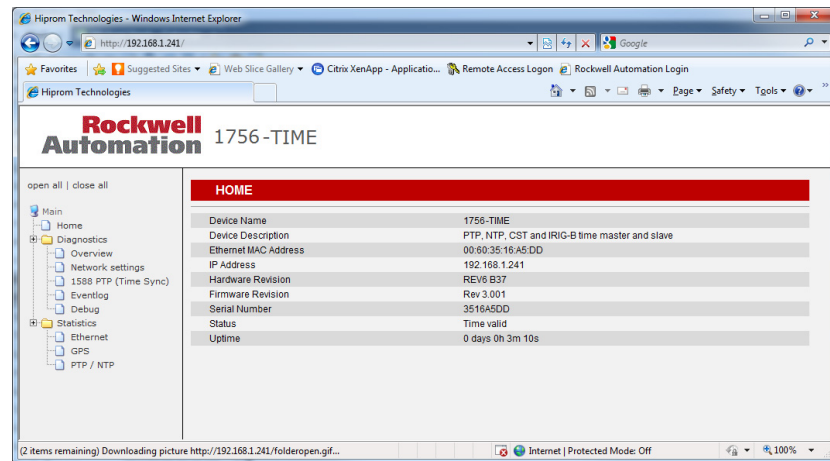

Time Synchronization

Topic	Page
1588 Precision Time Protocol (CIP Sync)	25
Network Time Protocol (NTP)	29
IRIG-B	32
CST and UTC Time Conversion	33
Time Synchronization Protocols	34

1588 Precision Time Protocol (CIP Sync)

The 1756-TIME module supports 1588 PTP, which enables high-precision time synchronization over an Ethernet network or the chassis backplane. When PTP is selected, both Ethernet and backplane synchronization is enabled.

In the case of PTP output, the module outputs time over both the backplane and Ethernet (if connected). In the case of PTP as a time source, the module searches for the best clock on both media.

See the Integrated Architecture® and CIP Sync Configuration Application Technique, publication [IA-AT003](#), for details on how to use this object.

IMPORTANT RSLogix 5000® software, version 18.00.00 and later, or the Studio 5000 environment, version 21.00.00 and later, supports 1588 PTP.
RSLogix 5000 software, version 17.00.00 and earlier, does not support 1588 PTP.

IMPORTANT The 1756-TIME module supports PTP software version 2.

1756-TIME Module as a PTP Master

When locked onto sufficient satellites, the 1756-TIME module can synchronize devices to within 100 ns (by using 1588 PTP) when connected directly to the device that is being synchronized. If these devices are connected via a switch that does not support 1588 PTP (transparent and boundary clock modes), the time synchronization degrades because there are more random delays that can affect the mean-delay time calculation that is used for time synchronization. Therefore, the more switches and interfaces between the 1756-TIME module and the devices being synchronized, the bigger the spread of random time delays that can result in lower time sync accuracy.

If you enable CIP Sync on a 1756-EN2T/1756-EN2TR module, the module looks for other 1588 PTP devices and syncs to the device that has the highest-quality clock.

IMPORTANT 1588 PTP uses a multicast address; therefore, set the switches to allow multicast, or have IGMP enabled.

IMPORTANT There is no direct communication between the 1756-TIME module Ethernet ports and a Logix5000 controller. If the 1756-TIME module resides in a remote Logix rack, the module must communicate through an EN2T(R) module in the same rack.

The 1756-EN2T/1756-EN2TR modules are boundary clocks that can be a slave clock on one interface, and a master clock on another interface. The modules can act as a transparent gateway when a Logix5000 controller uses the time Grandmaster (the 1756-TIME module) on the network. The 1756-EN2T/1756-EN2TR module must have CIP Sync and Motion enabled.

See [Configure the Ethernet Module/Controller PTP/CIP Sync Settings on page 27](#).

IMPORTANT Most devices that support 1588 PTP defaults to PTP Enabled: FALSE. PTP must be enabled on the devices before time synchronization can begin.

Configure the Ethernet Module/Controller PTP/CIP Sync Settings

Follow these steps to configure the PTP/CIP Sync settings of the 1756-EN2T/1756-EN2TR module and controller.

1. Open the AOP for the Ethernet module.
2. From the General tab, under Module Definition, click Change.

The screenshot displays the configuration interface for an Ethernet module. The 'General' tab is active, showing the following details:

- Type: 1756-EN2T 1756 10/100 Mbps Ethernet Bridge, Twisted-Pair Media
- Vendor: Allen-Bradley
- Parent: Local
- Name: ETH_MASTER
- Description: (empty)

The 'Module Definition' section is highlighted with a red box and contains the following information:

- Revision: 3.6
- Electronic Keying: Compatible Module
- Rack Connection: None
- Time Sync Connection: None

The 'Change ...' button in the 'Module Definition' section is also highlighted with a red box. The 'Ethernet Address' section shows the 'Private Network' option selected with the address 192.168.1.90. The 'Slot' is set to 1.

- From the Time Sync Connection pull-down menu, choose Time Sync and Motion.

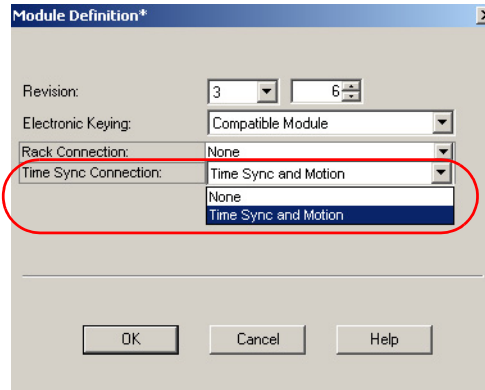

- Click OK.

The 1756-EN2T/1756-EN2TR module is now configured for PTP synchronization.

- To enable synchronization on the controller, open the Controller AOP.
- On the Date/Time tab, check the Enable Time Synchronization box.

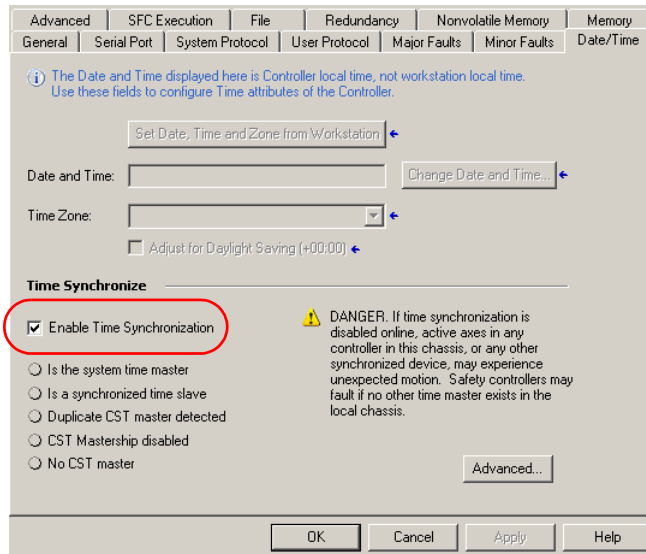

The Logix5000 controller looks for the highest-quality clock on the backplane.

- Click OK.

The settings of the Ethernet module and controller module are now configured for time sync and motion.

PTP as a Time Source

The 1756-TIME module can be set to be a PTP slave. The module synchronizes to the best PTP clock on either the backplane or the Ethernet network, by using the best master clock algorithm (BMC).

IMPORTANT The TIME module cannot act as a boundary clock. If PTP is selected as the input time source, then PTP output is disabled.

When you use PTP as the time source, it enables NTP and IRIG-B as the output modes. Therefore, the accuracy is limited to the accuracy of the respective output modes.

IMPORTANT The accuracy of the PTP time is dependent on the quality and reliability of the Ethernet network. The PTP algorithm allows for network delays, but needs a constant delay to synchronize accurately. PTP switches prioritize PTP messages to keep the delay constant, and are preferred for PTP networks.

Network Time Protocol (NTP)

This section describes how to configure the 1756-TIME module as an NTP server or an NTP client.

1756-TIME Module as an NTP Server

The 1756-TIME module supports NTP, which provides time synchronization over an Ethernet network. NTP clients can be synchronized to 1 ms of the NTP client, depending on the network configuration and reliability.

NTP is typically used when synchronizing personal computers or domain controllers. You can use the Software Network Time Protocol (HSNTP) application to set the Windows time service on a personal computer to synchronize to the 1756-TIME module. Download the HSNTP application from www.ab.com.

IMPORTANT The 1756-TIME module supports NTP version 3, RFC1305.

IMPORTANT When a computer is on a domain, it tries to synchronize to the domain controller. Therefore, you can configure the domain controller to synchronize to the 1756-TIME module.

Configure Windows NTP Settings

Follow these steps to configure the Windows time service to synchronize to the 1756-TIME module. The time module and computer must be on the same Ethernet network to use NTP.

1. Open the HSNTTP application.

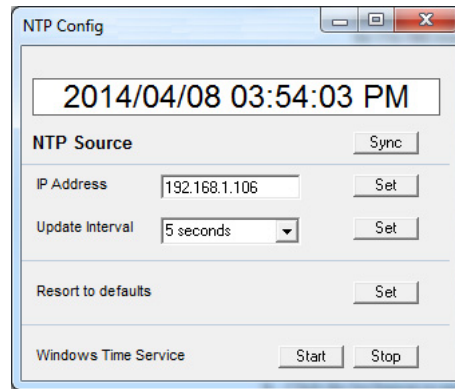

2. Enter the IP address of the NTP source (the 1756-TIME module).
3. Click Set to update the IP address.
4. From the Update Interval pull-down menu, choose an update interval time.
5. Click Set to update the update interval time.
6. Click Stop to stop the time service and load the new settings.
7. Click Start to start the time service.
8. To synchronize time with the NTP server, click NTP Source Sync.

The Windows time service is now configured to synchronize to the 1756-TIME module. To reset the defaults, click Set next to 'Resort to defaults'.

1756-TIME Module as an NTP Client

You can configure the 1756-TIME module to connect to an external NTP source, and then output the time as PTP or IRIG-B time.

TIP You can also use the SNTP protocol for the source.

Follow these steps to configure the 1756-TIME module to an NTP source.

1. Open the Time module AOP in RSLogix 5000® software.

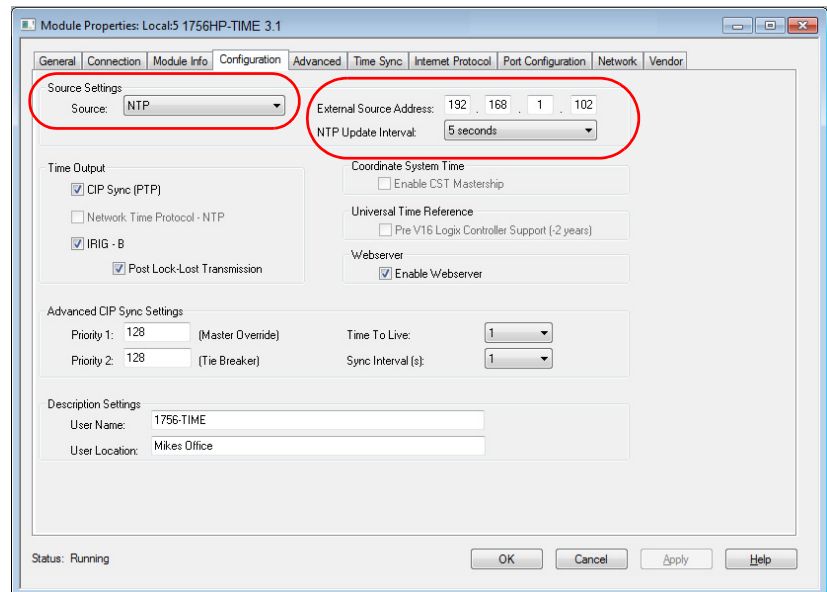

2. Click the Configuration tab.
3. From the Source Settings pull-down menu, choose NTP as the source.
The External Source Address and NTP Update Interval options become available.
4. In the External Source Address field, enter the IP address of the NTP source.
5. From the NTP Update Interval pull-down menu, choose the update interval for the 1756-TIME module to adjust its internal clock to the NTP source.

The update interval can range from 5 seconds to 1 week.

TIP The frequency of the update interval affects the accuracy of the time from the 1756-TIME module. If the time is not adjusted by the NTP source, the time can drift by up to 10 μ s/s depending on external factors, such as temperature and humidity.

6. Click OK.

The 1756-TIME module is now configured to an NTP source.

Time Adjustments

To keep the time of the 1756-TIME module as smooth as possible, the time is adjusted in small increments (ramp) until it is equal to the NTP source. If the time of the 1756-TIME module drifts more than 1 second off the source time, the 1756-TIME module jumps to the time given by the NTP source.

IMPORTANT The accuracy of the NTP time depends on the quality and reliability of the Ethernet network. If the update time is set too high, the clock can drift and jump. Rockwell Automation® recommends a value of 30 seconds or less for optimal accuracy.

Loss of Communication

If the 1756-TIME module loses its connection to the NTP source (if the source does not reply after the update interval time has expired), then the PPS and SYNC indicators illuminate red, the TimeValid bit is set to FALSE, and the 1756-TIME module runs on its internal oscillator until the NTP source becomes available again. The 1756-TIME module tries to reconnect to the NTP source every 10 seconds after a loss of communication.

IMPORTANT NTP time as a source is accurate to 10 ms; therefore, the synchronization accuracy of the output 1588 PTP is limited to 10 ms.

IRIG-B

The 1756-TIME module can be used as an IRIG-B master clock (outputs the IRIG-B signal) or an IRIG-B slave clock (receives the IRIG-B signal from another master clock). The time is transmitted over a coaxial cable, which plugs into the BNC connector at the bottom of the 1756-TIME module.

IMPORTANT The 1756-TIME module currently supports the IRIG-B-122 format.

1756-TIME Module as an IRIG-B Master

When the 1756-TIME module is an IRIG-B master clock, it sends the current time over the IRIG-B network and synchronizes slave clocks to 1ms.

The 1756-TIME module does not send the current year over the IRIG-B network.

1756-TIME Module as an IRIG-B Slave

The 1756-TIME module can synchronize to an external IRIG-B source by using coaxial cable. The source must output the IRIG-B 122 format time.

IMPORTANT The current year for the IRIG-B format is not supported by the 1756-TIME module. Therefore, you must supply the current year in the output image of the module in RSLogix 5000 software. A simple rung of ladder logic increases the year without your intervention.

You can also use the 1756-TIME module to output 1588 PTP and NTP while receiving time from an IRIG-B source.

IMPORTANT If using PTP as an output, you must also supply the UTC offset in the output image. The current value is 35, but the value changes periodically. To keep up to date, this page lists the current value.
http://en.wikipedia.org/wiki/Leap_second.

IMPORTANT If the 1756-TIME module has an IRIG-B time source that is accurate to 1 ms, then the synchronization accuracy when using 1588 PTP is also limited to 1 ms.

CST and UTC Time Conversion

This process is not needed for RSLogix 5000 software version 18.00.00 or later.

The 1756-TIME module can also be used to convert CST or UTC time formats to Gregorian time (year, day, month, and so on). The GPS module accurately tracks the local CST and UTC time to the current Gregorian time. Therefore, the different drifting rates of the CST are also compensated for.

In a sequence-of-events (SOE) solution, the SOE module (for example, the 1756-IB16ISOE module) reports the event time in either CST or UTC time formats.

IMPORTANT One CST master clock must be present for a sequence-of-events solution. Verify that there is no duplicate CST master clock. This is indicated in 1756-TIME module and the Logix controller.

These values are passed to the 1756-TIME module (by using unconnected message blocks) and converted to Gregorian time. The 1756-TIME module tracks the last 12 hours of CST, UTC, and Gregorian time formats. If an event has occurred, you have up to 12 hours to convert the event time. See [CST/UTC Conversion Message Blocks on page 43](#) for these message formats.

The CST offset can also be used to adjust the wallclock by using a set system values (SSV) instruction to pass the CST offset.

Time Synchronization Protocols

From the earliest days of networked computing, time synchronization has been important for precise computing applications. Standard clock time is inherently inaccurate and takes on added complexity in a distributed system, in which several computers must realize the same global time. As the need for more precise time synchronization has increased, several protocols have been developed to control and monitor system time.

Two of the most common protocols that govern time transfer are Network Time Protocol (NTP) and Inter-Range Instrumentation Group (IRIG) time code. Although the accessibility of Ethernet is certainly an advantage, it is not always well-suited for precise time-synchronized applications.

On an NTP-based LAN, network devices and computer operating systems add latency and jitter that reduce synchronization accuracy to 1...2 ms. To compensate for this loss, NTP-based LANs often require separate cabling systems and dedicated clocks. Similarly, the IRIG protocol requires physical modifications, such as a dedicated system of coaxial cables to carry timing signals directly between IRIG B clocks, separate from any data network.

Since it was established over a decade ago, the IEEE 1588-2008 Precision Time Protocol (PTP) has addressed the clock synchronization requirements of measurement and control systems by improving accuracy and reducing cost. Among the many advantages of PTP are the fact that the protocol uses the most readily available means for network connectivity: IP over Ethernet.

Taking advantage of the existing Ethernet infrastructure allows considerable reuse of in-place hardware and cabling, helping to reduce costs for the physical layer. PTP helps minimize Ethernet latency and jitter issues through hardware time stamping to cancel out a measured delay between nodes at the physical layer of the network. Accuracy in the range of 10...100 ns can be achieved.

NTP vs. IRIG vs. PTP

NTP has been the most commonly used protocol because it is ubiquitous, inexpensive, widely available, works well over LANs and WANs, and requires little hardware. However, due to the use of switches and routers on LANs and WANs and the fact that many NTP clients run on non-real-time operating systems, such as Windows or Linux, NTP protocol accuracy cannot be guaranteed, see [Figure 5 on page 35](#). On the Windows operating system, for instance, clock corrections of 10...50 ms are common, because the system is busy performing tasks that it deems more important than timekeeping.

The IRIG protocol would seem to be a better choice. The IRIG protocol offers accuracy of up to 1...10 ms. This time code is often used in precision timing-critical applications: military, aerospace, and power utility instrumentation. Because IRIG systems use dedicated coaxial timing cabling between dedicated hardware clocks, the system has its disadvantages. Most notable disadvantages are the added expense of additional hardware and the increased time skew due to the added physical infrastructure required.

PTP, with its innate hardware-assisted time stamping, lets you take advantage of the cost-effectiveness of NTP protocols by using existing Ethernet LANs, with accuracy better than that delivered by IRIG clocks. PTP can operate with normal Ethernet network traffic on a LAN with switches, while maintaining synchronization accuracy to the sub-microseconds.

IEEE 1588 boundary clocks and transparent switches help achieve 20...100 ns synchronization accuracy.

Figure 5 - Sync Accuracy

Protocol	Media	Sync Accuracy
NTP	Ethernet	50-100 milliseconds
IRIG-B	Coaxial	1-10 microseconds
PTP	Ethernet	20-100 nanoseconds

Network Time Protocol (NTP)

Network Time Protocol (NTP) is used to synchronize time across an IP network. It uses port 123 as both the source and destination, and runs over the User Datagram Protocol (UDP). The NTP network generally uses a time source such as a radio or atomic clock that is attached to the main time server, then the NTP server distributes the time across the network.

No more than one NTP transaction per minute is necessary to achieve 1 millisecond synchronization on a local area network. For larger systems (wide-area networks), NTP can routinely achieve 10 millisecond synchronization. However, the level of synchronization is not guaranteed and can be affected by the infrastructure.

An NTP enabled device never synchronizes to a device that is not synchronized itself. Additionally, an NTP enabled device compares the time reported by several NTP devices, and will not synchronize to a device whose time is different than others.

NTP has widely been deployed in enterprise level networks, and must be considered when deploying plant-wide networks that require synchronized time across multiple Cell/ Area Zones. Because of the absence of PTP enabled network devices at the Manufacturing Zone and higher, the implementation of NTP could be advantageous in the industrial setting. If, for instance, a plant would like to piece together a sequence of events, it is necessary to have a common understanding of time. At the Cell/Area Zone level, it is best to implement PTP. However, at a higher level, there can be a greater number of devices that support NTP.

Simple Network Time Protocol (SNTP)

Some devices only support Simple Network Time Protocol (SNTP), which is a simplified, client-only version of NTP. SNTP enabled devices cannot be used to provide time to other devices, they only receive time from NTP servers. The SNTP enabled devices can achieve synchronization levels within 100 milliseconds.

NTP Server Choice

Many devices can be an NTP Server, there can also be multiple servers on the network. There are also publically accessible NTP servers, which you can learn about by visiting [NTP Pool Project](#).

Most IT departments have their own NTP server that runs internally, either on a standalone server, or within a switch or router. All clocks on the LAN can be synchronized to that server. It is acceptable to use these existing NTP servers from the Manufacturing Zone (Level 3) up through the Enterprise Network.

There is nothing that is built into the NTP protocol to compensate for multiple hops through a large network. Therefore, the larger the network, the larger the possible a time delay, which can be introduced into the system.

IRIG B-122 Protocol

IRIG time codes are another method of time synchronization that is used in the 1756-TIME module. This module is the only Rockwell Automation product that supports the IRIG standard. For this reason, we typically recommend using NTP or PTP when possible.

IRIG also requires additional hardware and cabling, whereas the other two methods use Ethernet. IRIG is used primarily when it is necessary to synchronize time across large geographic areas. To date, this system has been implemented primarily in large communication systems, data handling systems, missile and spacecraft tracking, and in large mining operations.

Rockwell Automation uses the modulated IRIG B-122 implementation on the 1756-TIME module for time synchronization. With this implementation, it is possible to achieve synchronization within 1 ms.

Precision Time Protocol (PTP) – IEEE 1588-2008

EtherNet/IP uses CIP Sync to synchronize device clocks on the Ethernet network. CIP Sync is the name that is given to time synchronization services for the Common Industrial Protocol. CIP Sync uses the IEEE 1588 Standard for a Precision Clock Synchronization Protocol for Networked Measurement and Control Systems, referred to as Precision Time Protocol (PTP), to synchronize devices to a high degree of accuracy.

The IEEE 1588 standard specifies a protocol to synchronize independent clocks that run on separate nodes of a distributed control system to a high degree of accuracy and precision.

The clocks communicate with each other over a communication network. In its basic form, the protocol is intended to be administration-free. The protocol generates a master-slave relationship among the clocks in the system by determining which of the possible sources has the better accuracy. All clocks ultimately derive their time from a clock that is known as the Grandmaster clock.

Once the clocks in a control system share a synchronized, common understanding of system time, events being monitored in the control system (for example, the ControlLogix system) can be time that is stamped to a high degree of accuracy.

For more information about Precision Time Protocol, see these publications:

- Converged Plantwide Ethernet Design Implementation Guide, publication [ENET-TD001](#).
- Integrated Architecture and CIP Sync Configuration and Application Technique, publication [IA-AT003](#).

Example Architectures

In this architecture, NTP is used to facilitate time management from Levels 3...5. The capability to do this facilitation can be placed in existing Enterprise networks. Between Levels 3 and 2, a conversion from NTP to PTP takes place. This conversion provides more accurate synchronization at the Cell/ Area Zone level.

The plant-wide network still has similar clocks relative to each other, providing for plant-wide Sequence of Events to take place. This architecture is best fit for a plant where an existing NTP server is in place, or for a plant where time synchronization between VLAN's and subnets is necessary, as PTP is not a routable protocol.

For smaller architectures, where an existing NTP server may not be present, and where there is only one subnet and VLAN, the following architecture would be appropriate. In this system, the 1756-TIME module sits between the Cell/Area Zones and the rest of the plant. The module acts as both the PTP Grandmaster for the entire VLAN/Subnet, as well as the NTP server for the rest of the plant.

Since the clock on the module is more accurate than that found on a computer, this system has an overall more accurate clock. Again, it is important to note that this architecture is only appropriate for systems with one subnet and VLAN, as PTP is not routable.

Figure 6 - Example Architecture

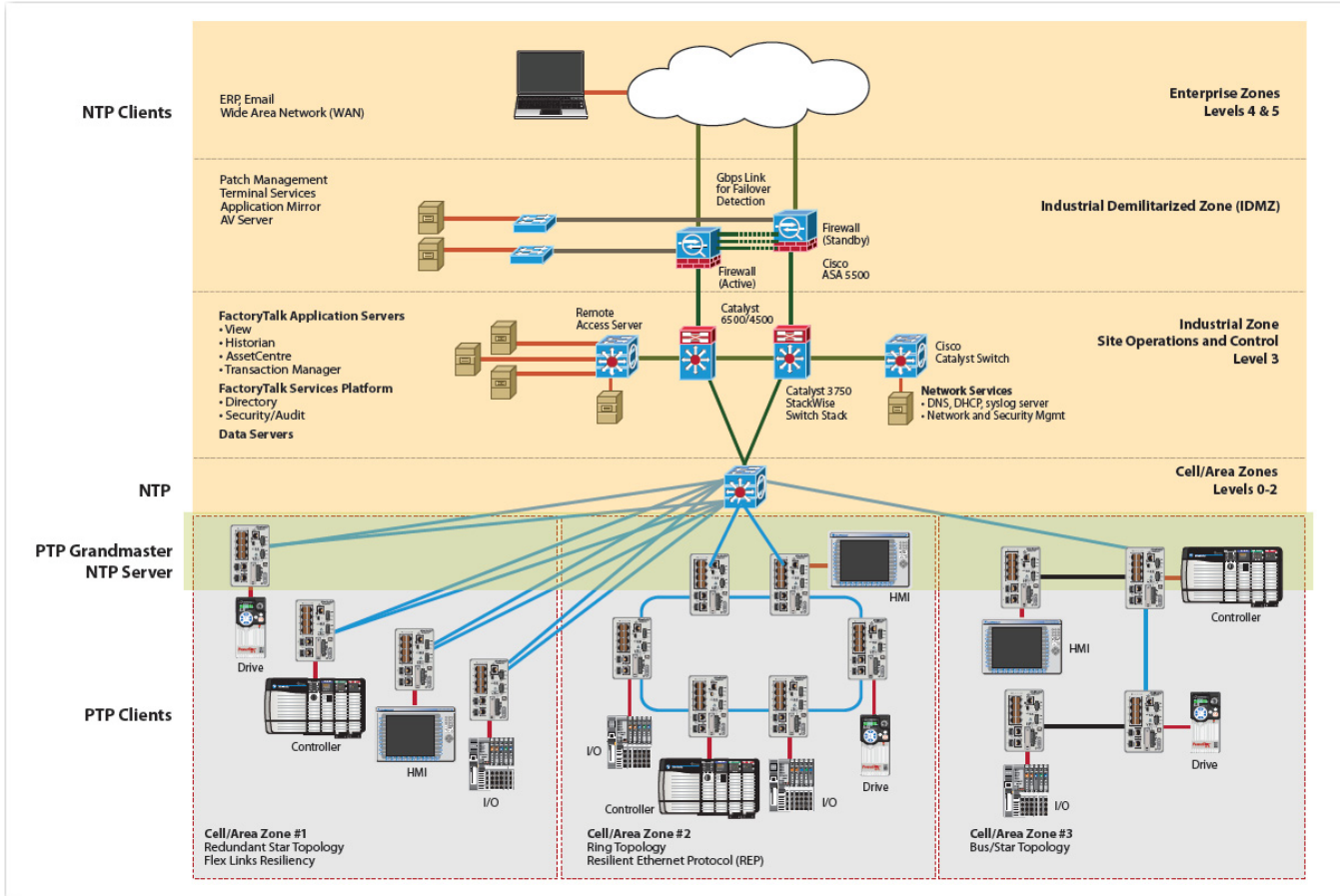

1756-TIME Module and NTP Client Functionality

Thus far, the discussion has been on achieving time synchronization across the plant floor by using NTP. However, the NTP mechanism is not extremely accurate, so it is not the best solution for all situations. For instance, at the Cell/Area Zone level, an integrated motion system may be implemented. For integrated motion, it is necessary to implement PTP, which requires a Grandmaster. To use the NTP time that is already propagating through the plant, you have to convert NTP to PTP at the Cell/Area Zone level.

You can use the dual-port embedded switch on the front of the 1756-TIME module as the conversion point for NTP to PTP.

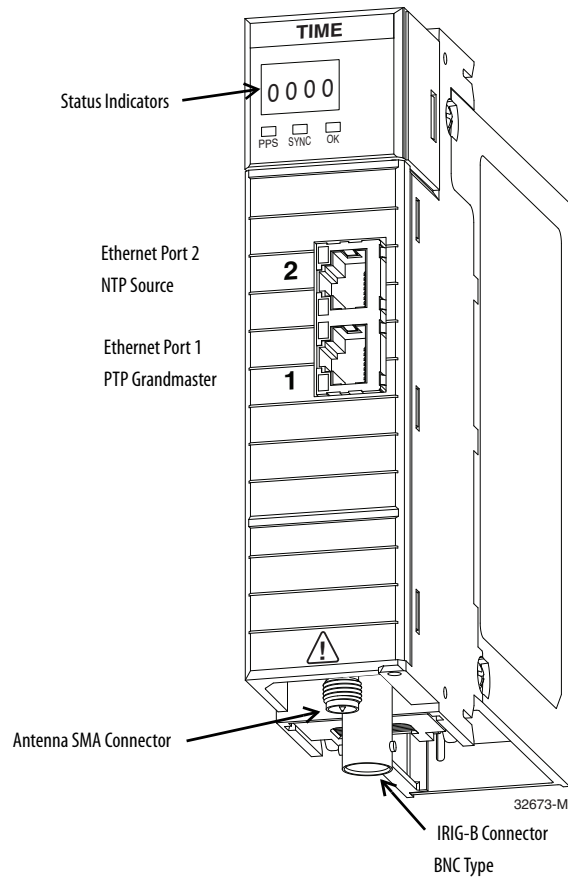

This conversion can be achieved by using the 1756-TIME module, along with its NTP Client capability. When configuring the module choose NTP as the source, rather than GPS. Then insert the NTP server IP address into the module.

You can also force priority for CIP Sync Grandmaster from this tab.

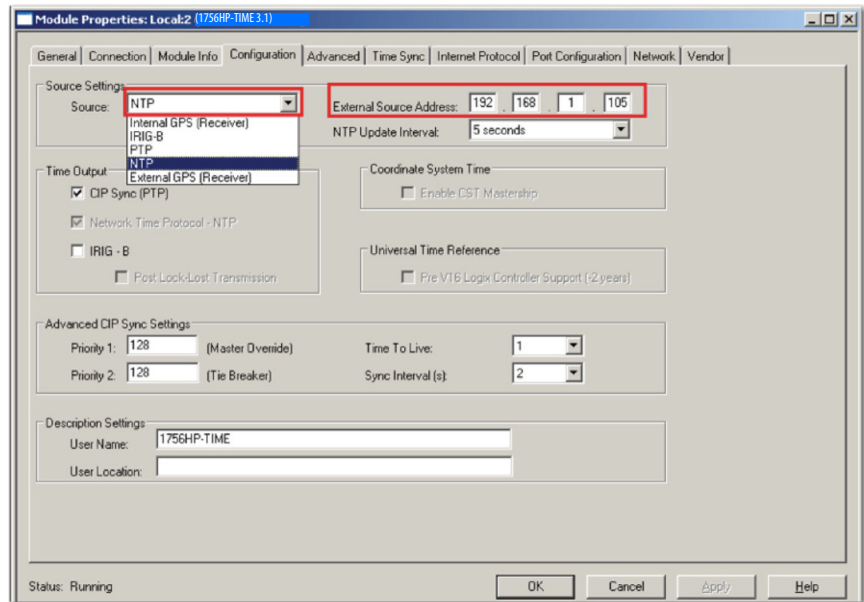

To bypass the GPS mechanism in the 1756-TIME module, it is necessary to put the module into 'Simulation Mode,' which can be found in the Advanced Tab.

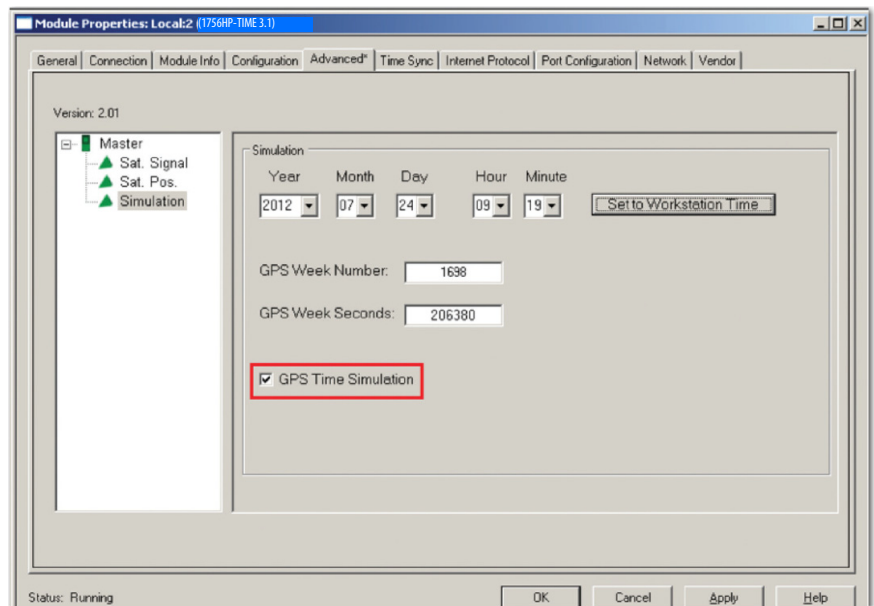

1756-TIME Module Status Indicators

Topic	Page
Status Indicators	41
Status Messages	42

The display on the front of the 1756-TIME module provides status indicators and status messages.

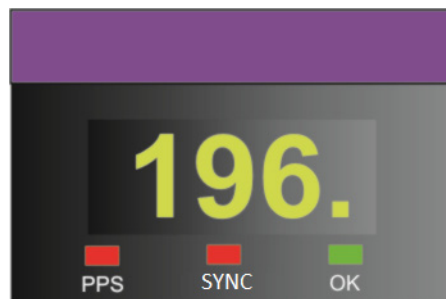

Status Indicators

The 1756-TIME module provides three status indicators on the display.

Status Indicators	Description
PPS	This indicator is toggled every second for 100 ms at the exact PPS. Green = the module is locked on the time source. Red = the module is not locked on the time source. When the module is set to be an IRIG-IN or slave clock, this indicator is toggled every time a reference frame is received.
SYNC	Green = the module is locked on the time source. Red = the module is not locked on the time source.
OK	Green = the module has started successfully. Red = the module has a hardware fault.

Status Messages

The 1756-TIME module provides the following status messages on the display.

Status Message	Description
192.168.1.100	Indicates the IP address of the 1756-TIME module.
Source: X	Indicates the current time source being used. The sources are GPS, IRIG-B, NTP, and PTP.
BOOTP Enabled	Indicates that BOOTP is currently active on the module. Use a BOOTP server to set the IP address.
Sat Count X	The GPS receiver is locked onto X number of satellites.
No Time Lock	The time has not been received.
Time Locked	The module is locked to the selected time source.
Firmware update in progress, do not power down!	Indicates that a firmware update is in progress.
OK	Indicates that the module is operating correctly.
RESET	Indicates that the module has received a reset command.
TEST	The module displays this on startup when it is performing self-diagnostics to make sure that the hardware is working properly.
PTP Source X	Displays either the IP address (Ethernet CIP Sync) or slot number (Backplane CIP Sync) of the PTP source.
PTP Source Unreachable	Indicates that there is no PTP source on either the backplane or Ethernet network.
NTP Source X	Displays the IP address of the NTP Source
NTP Source Unreachable	Indicates that there is no NTP source on Ethernet network.
Provide IRIG-B Year	The Output image does not have a valid year for the IRIG-B signal.
BL. Err X - Y	An error has occurred in the initialization of the module. X is the error code, and Y is the description of the error.
Err X - Y	An error has occurred during operation. X is the error code, and Y is the description of the error.

CST/UTC Conversion Message Blocks

Topic	Page
CST to UTC and Gregorian Time Conversion	43
UTC to Gregorian Time Conversion	43
Satellite Information	44

CST to UTC and Gregorian Time Conversion

This table shows the structure of the message block for the CST to UTC and Gregorian time conversion.

Settings and Elements	Attribute	Value
Message settings	Message type	CIP generic
	Service type	Custom
	Service code	36h
	Class	72h
	Instance	01h
	Attribute	03h
Date elements	Source element	Event_CST[0] ⁽¹⁾
	Source length	8
	Destination	Event.Year ⁽¹⁾

(1) See the example code at <http://www.ab.com/>.

UTC to Gregorian Time Conversion

This table shows the structure of the message block for the UTC to Gregorian time conversion.

Settings and Elements	Attribute	Value
Message settings	Message type	CIP generic
	Service type	Custom
	Service code	36h
	Class	72h
	Instance	01h
	Attribute	04h
Date elements	Source element	Event_UTC[0] ⁽¹⁾
	Source length	8
	Destination	Event.Year ⁽¹⁾

(1) See the example code at <http://www.ab.com/>.

Satellite Information

This table shows the structure of the message block for the satellite information.

Settings and Elements	Attribute	Value
Message settings	Message type	CIP generic
	Service type	Custom
	Service code	36h
	Class	72h
	Instance	01h
	Attribute	09h
Date elements	Source element	-
	Source length	0
	Destination	SatInformation[0].PRN ⁽¹⁾

(1) See the example code at <http://www.com/>.

Operating Modes

Topic	Page
GPS Source	45
IRIG-B Source	46
PTP Source	46
NTP Source	47

GPS Source

The GPS source mode can have the following configurations:

- Source: GPS
- Outputs: IRIG-B, 1588 PTP/CIP Sync, NTP, and input/output assemblies.

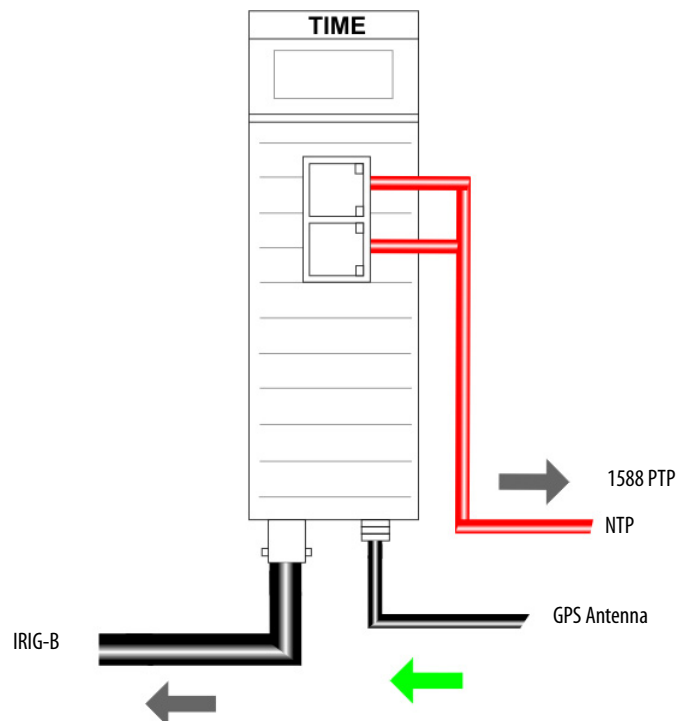

IRIG-B Source

The IRIG-B source mode can have the following configurations:

- Source: IRIG-B 122
- Outputs: 1588 PTP/CIP Sync, NTP, and input/output assemblies

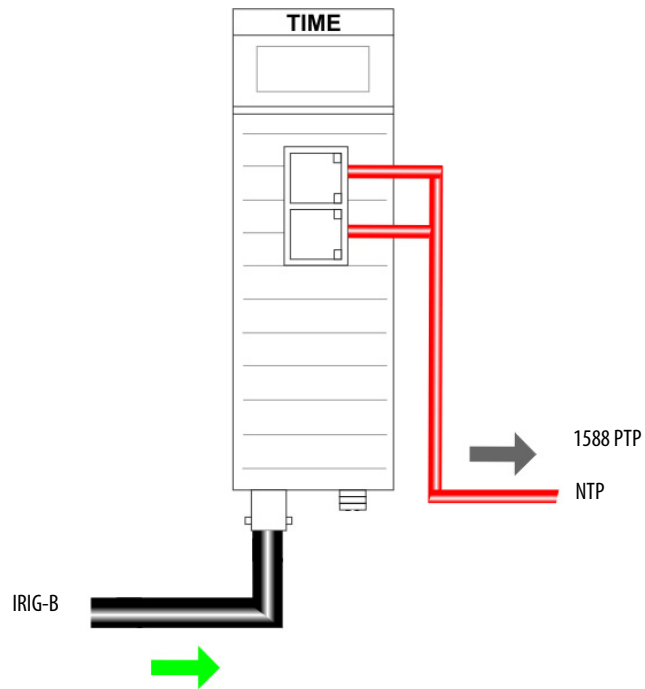

PTP Source

The PTP source mode can have the following configurations:

- Source: 1588 PTP/CIP Sync, either over Ethernet or the backplane
- Outputs: IRIG-B, NTP, and input/output assemblies

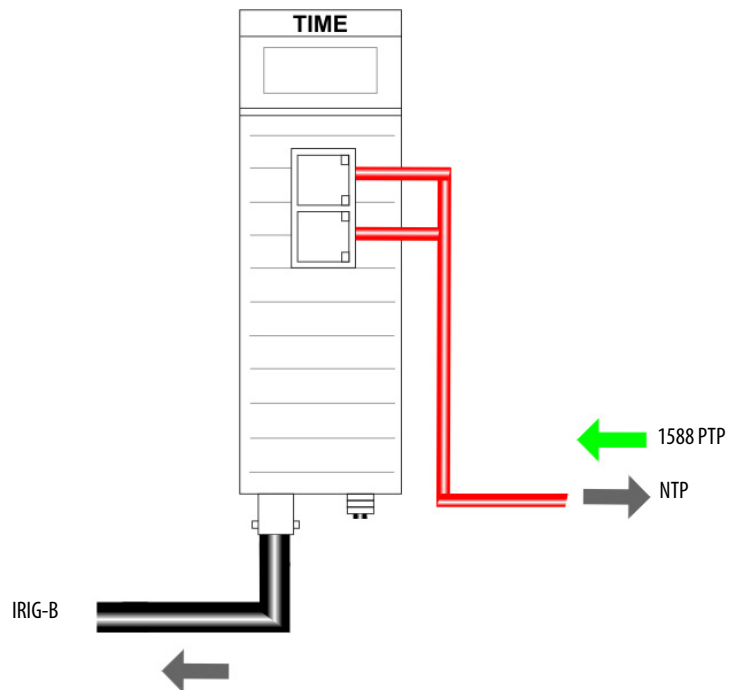

NTP Source

The NTP source mode can have the following configurations:

- Source: NTP, over Ethernet
- Outputs: IRIG-B, 1588 PTP/CIP Sync, and input/output assemblies

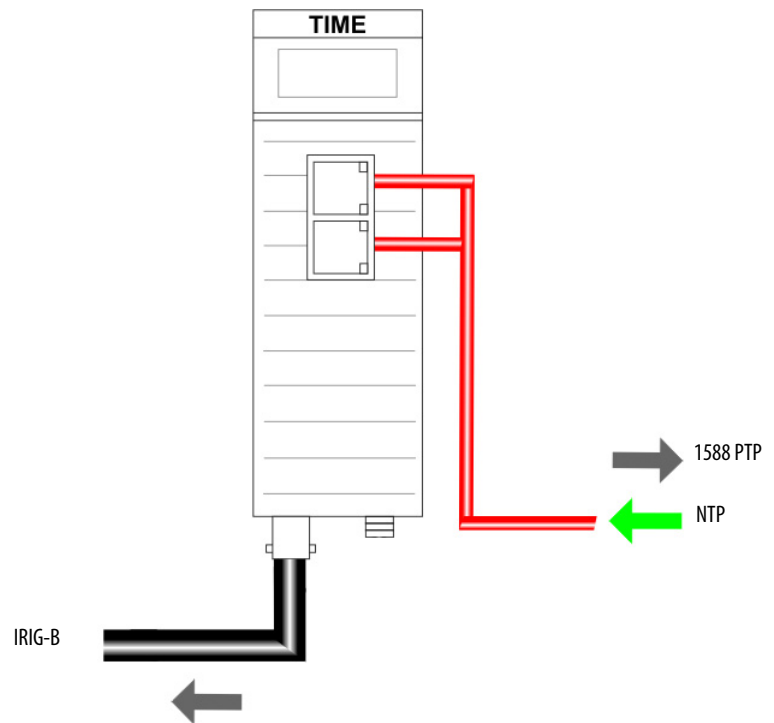

Notes:

GPS Antenna Cable Extensions

Topic	Page
Cable Extensions	49
Lightning Protection Devices	51
Trimble BX982 Setup	52

Cable Extensions

The 1756-TIME module ships with a 5 m (16 ft) RG58 coaxial cable. Rockwell Automation® does not supply longer cables. If you need a longer cable for your installation, follow the guidelines in this appendix to specify and purchase extensions from a cable supplier.

Determine the Length of the Cable

Determine the length of the cable by measuring the cable path from the 1756-TIME module to a position that provides the antenna with a 360° clear view of the sky. Plan your installation so the length of the cable path is as short as possible.

Determine the Attenuation Rate of the Cable

Determine the type and quality of cable and whether an amplifier is required. Use the cable attenuation tables of the manufacture. Determine the over-signal attenuation at 1.5 GHz. Keep the attenuation below 10 dB. Rockwell Automation recommends no more than 6 dB for better performance.

[Table 6](#) provides typical attenuation values (in dB) for common types of 50 Ω coaxial cable at 1.5 GHz. Light green shading shows acceptable levels of attenuation below 10 dB. Dark green shading is in the recommended range.

Table 6 - - Typical Attenuation Values in dB for Cable Extension, m (ft)

	5 (16)	10 (33)	15 (49)	20 (66)	25 (82)	30 (98)	35 (115)	40 (131)	45 (148)	50 (164)	55 (180)	60 (197)	65 (213)	70 (230)	75 (246)	80 (262)	85 (279)	90 (295)	95 (312)	100 (328)
Cable Type	Typical Attenuation Values in dB																			
RG58	3.1	6.3	9.4	12.5	15.7	18.8	21.9	25.0	28.2	31.3	34.4	37.6	40.7	43.8	47.0	50.1	53.2	56.3	59.5	62.6

	5 (16)	10 (33)	15 (49)	20 (66)	25 (82)	30 (98)	35 (115)	40 (131)	45 (148)	50 (164)	55 (180)	60 (197)	65 (213)	70 (230)	75 (246)	80 (262)	85 (279)	90 (295)	95 (312)	100 (328)
Cable Type	Typical Attenuation Values in dB																			
LMR-240	1.6	3.2	4.9	6.5	8.1	9.7	11.3	13.0	14.6	16.2	17.8	19.4	21.0	22.7	24.3	25.9	27.5	29.1	30.8	32.4
LMR-400	0.8	1.7	2.5	3.4	4.2	5.0	5.9	6.7	7.6	8.4	9.2	10.1	10.9	11.8	12.6	13.5	14.3	15.1	16.0	16.8
LMR-600	0.5	1.1	1.6	2.2	2.7	3.3	3.8	4.4	4.9	5.4	6.0	6.5	7.1	7.6	8.2	8.7	9.2	9.8	10.3	10.9

IMPORTANT LMR-400 and LMR-600 cables are too stiff and heavy to connect directly to the small SMA connector on the 1756-TIME module.
For these cables, use a fly lead to wire the connector.

If the attenuation from a lower loss cable (such as LMR 600) is greater than 10 dB, you must use an amplifier. Rockwell Automation does not supply amplifiers. If you need an amplifier for your installation, follow the guidelines in this appendix to specify and purchase an amplifier from a cable supplier. Amplifiers of 15 and 30 dB gain are typically available.

Verify that the signal gain through the amplifier, minus the attenuation from the cable, is in the range of +10 dB (gain) to -10 dB (loss). Mount the amplifiers as close to the antenna as possible without exposing them to the weather.

IMPORTANT Amplifiers must pass the 3.3V DC supplied by the GPS receiver to power the internal antenna amplifier, or provide the 3.3V DC internally.
If the amplifier blocks the DC component, it also needs to supply a dummy load to prevent the receiver from giving a false No Antenna fault.

Example – Determining Cable Requirements

Cable length that is required is 30 m (100 ft).

From [Table 6 on page 49](#), LMR-240 has a 9.7 dB loss that is acceptable, or LMR-400 can be used with a 5 dB loss. Because LMR-400 cannot be connected directly to the 1756-TIME module, a shorter length of RG58 can be used.

The antenna cable extension must connect to an SMA female connector on the 1756-TIME module, and a TNC female connector on the antenna. So the cable connectors must be SMA male to TNC male.

TIP Rockwell Automation recommends a TNC bulkhead connector for cable-to-cable connections.

Cable Extension Kits

The cable extension kits in [Table 7 on page 51](#) can be purchased from Millimeter Wave Technologies. For more information, visit the Millimeter Wave Technologies website, <http://mmwavetech.com/>, or call 1-480-941-2990.

Table 7 - Cable Extension Kits

Part No.	Cable Length m (ft)	Fly Lead 1	Bulkhead Connector	Main Cable	Amplifier	Fly Lead 2
ACK33	10 (33)	-	-	RG58-ST-33	-	-
ACK50	15 (50)	-	-	LMR240-ST-50	-	-
ACK66	20 (66)	-	-	LMR240-ST-66	-	-
ACK100	30 (100)	RG58-ST-6	BULKH-TT	LMR400-TT-100	-	-
ACK130	40 (130)	RG58-ST-6	BULKH-TT	LMR400-TT-130	-	-
ACK150	46 (150)	RG58-ST-6	BULKH-TT	LMR400-TT-150	-	-
ACK175	53 (175)	RG58-ST-6	BULKH-TT	LMR600-TT-175	-	-
ACK200	61 (200)	RG58-ST-6	BULKH-TT	LMR600-TT-200	-	-
ACK260	79 (260)	RG58-ST-6	BULKH-TT	LMR600-TT-260	A11-P110/3.3-TF 15 dB	RG58-TT-6
ACK300	300 (91)	RG58-ST-6	BULKH-TT	LMR600-TT-300	A11-P110/3.3-TF 15 dB	RG58-TT-6
ACK360	110 (360)	RG58-ST-6	BULKH-TT	LMR600-TT-360	A11-P110/3.3-TF 15 dB	RG58-TT-6

Lightning Protection Devices

Rockwell Automation recommends lightning protection devices that are capable of receiving multiple strikes, with a clamping voltage above the 3.3V DC that is required by the antenna (such as a Polyphaser DGXZ+06NFNF device). Mount the lightning protection device outside, with an earth ground.

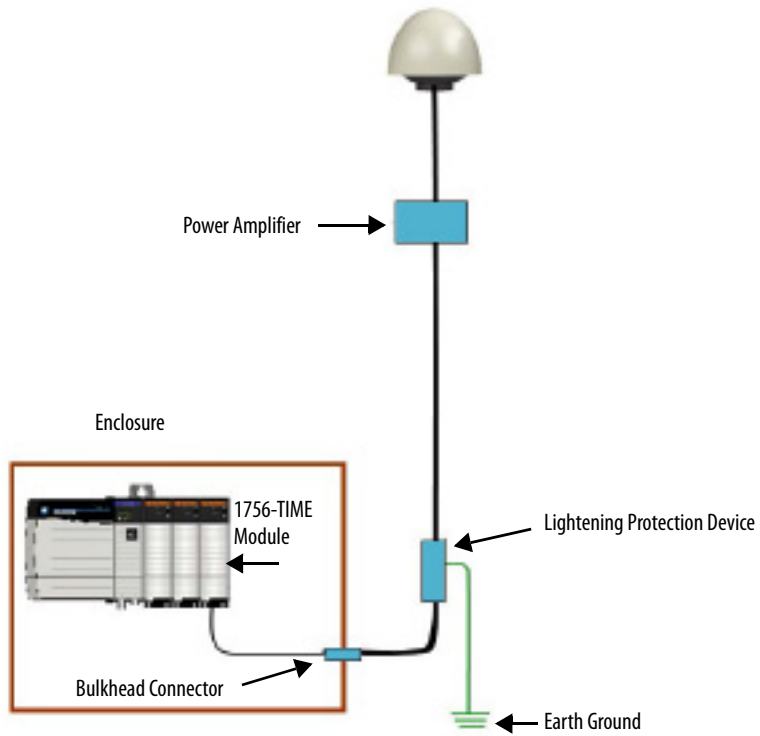

Trimble BX982 Setup

Open a web browser, and point the address to the configured IP address of the BX982. The default username and password are 'admin' and 'Password' respectively.

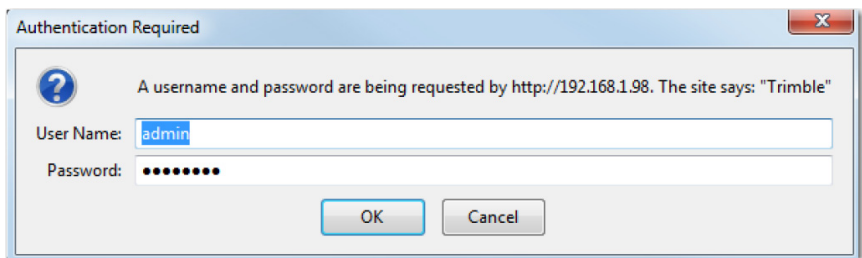

The following page displays.

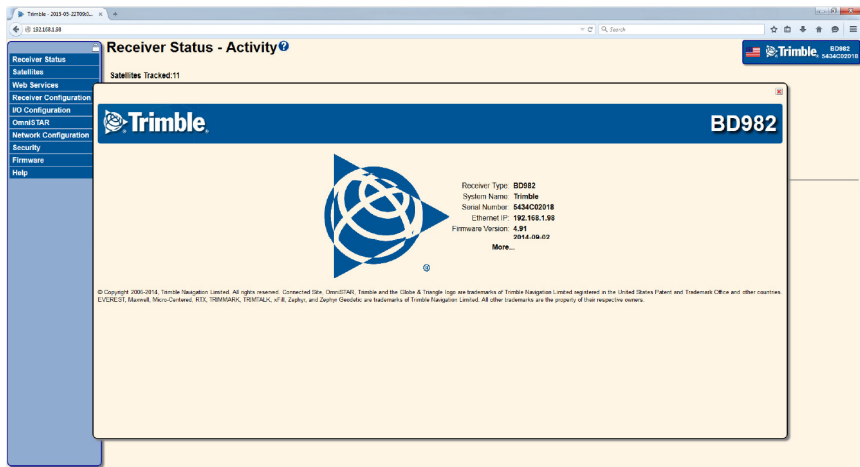

The navigation pane on the left-hand side can be used to view various status, activity, and configuration parameters of the BX982 unit.

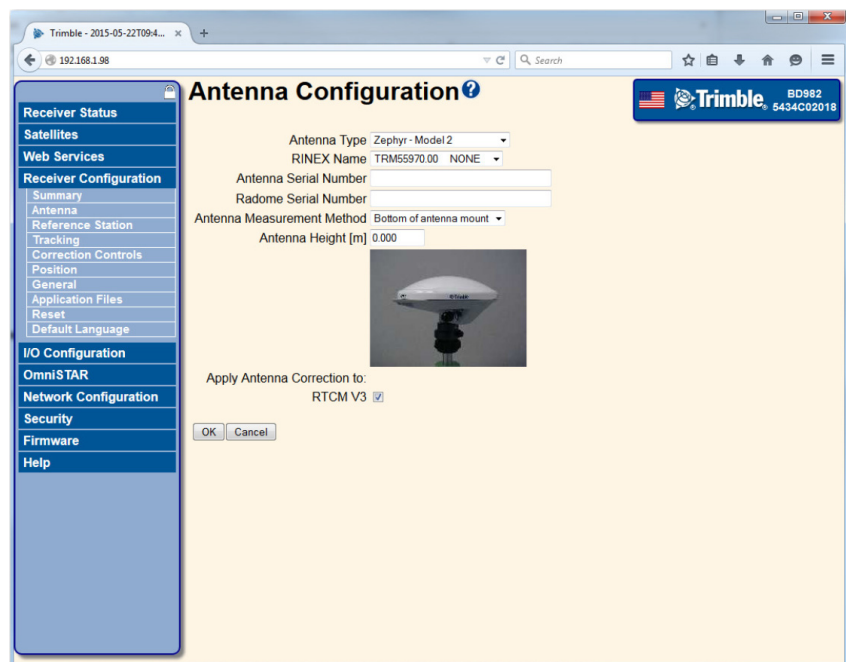

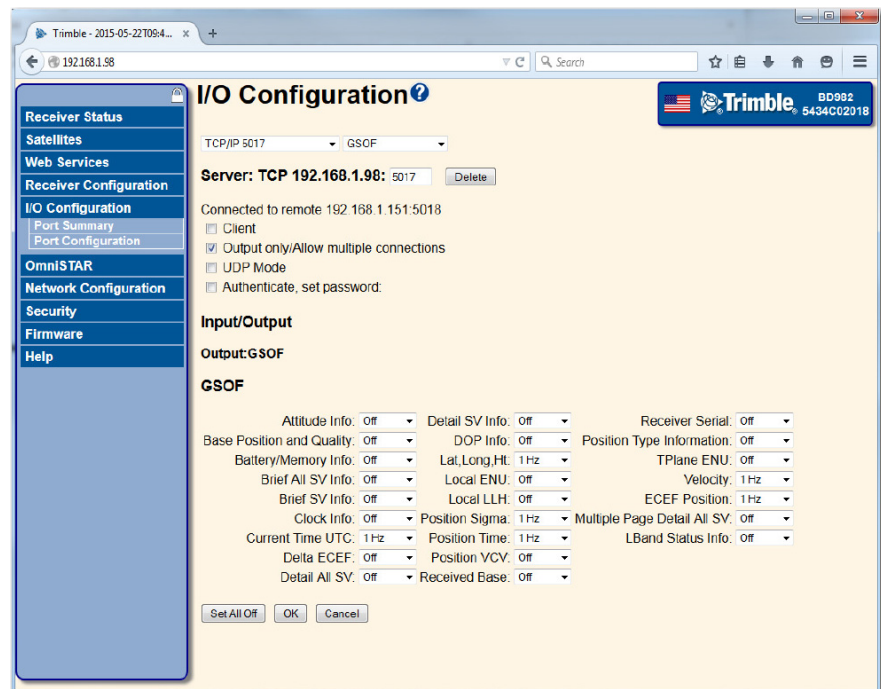
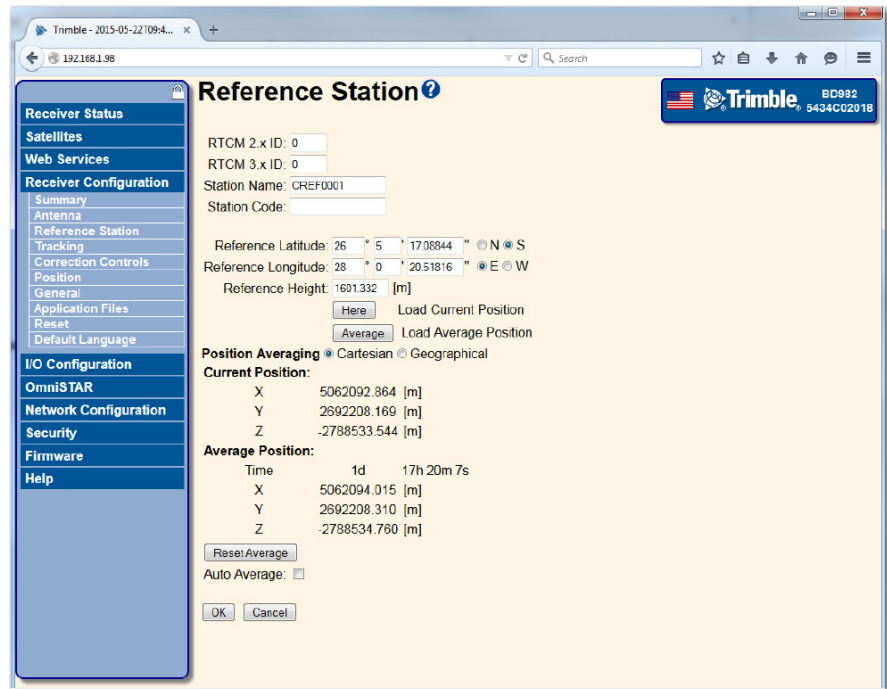

Base Station with Rover Setup

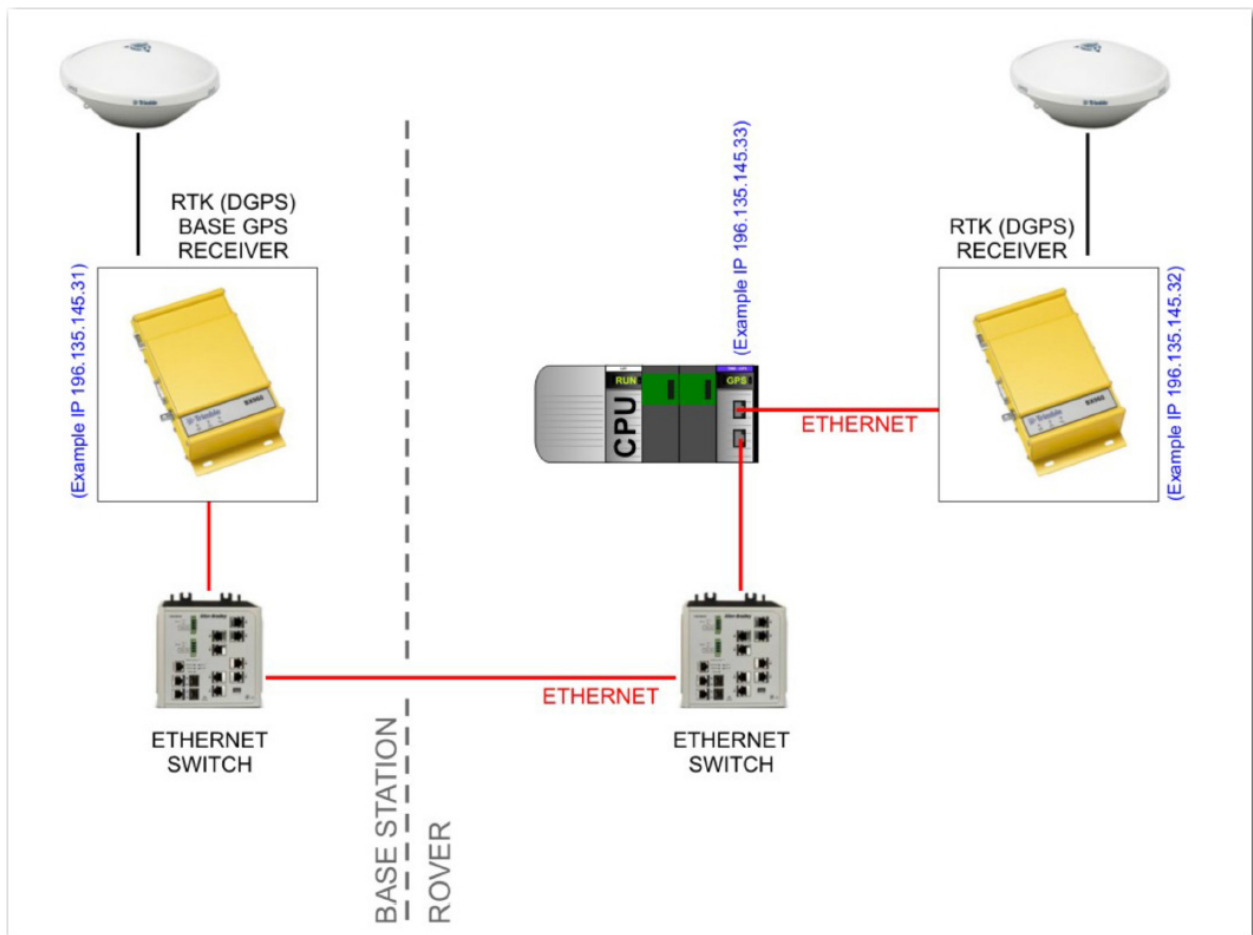

Base Station Setup

1. Install the unit in a suitable position such that the antenna has an unimpeded view of the sky.
2. Connect to the unit by using the configured IP address.

To accomplish this, follow the manufacturer's instructions.
3. Log in to the web server by using the default security parameters:
 - Username: admin
 - Password: password
4. Navigate to Receiver Configuration | Antenna, and select the correct antenna configuration.

The unit now starts to track satellites and resolves its position.

5. Navigate to Receiver Configuration | Reference Station and select the “Load Current Position” by pressing the “Here” button.
6. Navigate to I/O Configuration | Port Configuration and add a new TCP/IP port, as follows:
 - Type: CMR
 - Port: 5018
 - Client: Off
 - Output Only: On
 - UDP Mode: Off
 - Delay: 0 ms

Rover Setup

1. Install the unit in a suitable position such that the antenna has an unimpeded view of the sky.
2. Connect to the unit by using the configured IP address.

To accomplish this, follow the manufacturer’s instructions.

3. 3. Log in to the web server by using the default security parameters:
 - Username: admin
 - Password: password
4. Navigate to Receiver Configuration | Antenna, and select the correct antenna configuration.

The unit starts to track satellites and resolves its position.

5. Navigate to I/O Configuration | Port Configuration and add a new TCP/IP port, as follows:
 - Type: GSOF
 - Port: 5017
 - Client: Off
 - Output Only: On
 - UDP Mode: Off
 - Remote IP: (IP address of Base Station): 5018
 - CMR Input: Disabled
6. Select the following Input/Output GSOF messages, with a 1 Hz frequency.
 - Current Time UTC
 - Lat, Long, Ht
 - Position Sigma
 - Position Time
 - Velocity
 - ECEF Position

The following terms and abbreviations are used throughout this manual. For definitions of terms that are not listed here, refer to the Allen-Bradley® Industrial Automation Glossary, publication [AG-7.1](#).

- Add-On Instructions** Add-on instructions are custom RSLogix 5000® software and the Logix Designer application instructions that you design and create. With add-on instructions, you can create instructions for sets of commonly used logic, provide a common interface to this logic, and provide documentation for the instruction.
- Best Master Clock Algorithm** The algorithm that each node performs to determine the clock that becomes the master clock on a subnet and the Grandmaster clock for the domain. The algorithm primarily compares priority1, clock quality, priority2, and source identity to determine the best master among available candidates.
- Boundary Clock** A boundary clock has multiple ports, for example, a managed Ethernet switch, and perform the duties as a master or slave clock.
- Common Industrial Protocol (CIP)** The Common Industrial Protocol (CIP) is an open industrial protocol for industrial automation applications.
- CIP Sync** CIP Sync is the Open DeviceNet Vendors Association (ODVA) implementation of the Institute of Electrical and Electronics Engineers (IEEE) 1588-2008 standard. The protocol provides a mechanism to synchronize clocks between controllers, I/O devices, and other automation products.
- Clock** A node that participates in the PTP protocol that is capable of providing a measurement of the passage of time since a defined epoch. There are three types of clocks in IEEE 1588-2008: boundary, transparent, and ordinary clocks.
- Coordinated System Time (CST)** In its simplest form, CST is a backplane clock that is propagated between all modules on the ControlLogix® backplane. Its presence is necessary whenever time coordination between modules in the chassis is required.
- Device Level Ring (DLR)** A DLR network is a single-fault tolerant ring network that is intended for the interconnection of automation devices. This topology is also implemented at the device level. No additional switches are required.
- Domain** A logical grouping of clocks that synchronize to each other by using the PTP protocol, but that are not necessarily synchronized to clocks in another domain.
- Greenwich Mean Time (GMT)** GMT is the mean solar time of the longitude (0°) of the former Royal Observatory at Greenwich, England, or Greenwich meridian. UTC replaced GMT as the basis for the main reference time scale or civil time in various regions on 1 January 1970.
- Global Positioning System (GPS)** GPS is a satellite-based navigation system that is composed of a network of 24 satellites that are placed into orbit by the U.S. Department of Defense. A GPS provides timing services (as well as positioning and navigation) on a continuous basis in all weather, day and night, anywhere on or near the Earth that has an unobstructed view of four or more GPS satellites.

- Grandmaster (GM)** Within a domain, a clock that is the ultimate source of time for clock synchronization by using the CIP Sync protocol.
- Local Clock** The clock on a device.
- Master Clock (M)** In the context of one CIP Sync communication path, a clock that is the source of time to which all other clocks on that path synchronize on a local subnet.
- Network Time Protocol (NTP)** A protocol for synchronizing the clocks of computer systems over packet-switched, variable-latency data networks.
- Priorities (P1 and P2)** Parameters that can override the best master clock algorithm to choose another Grandmaster.
- Precision Time Protocol (PTP)** The PTP protocol is a time-transfer protocol that is defined in the CIP Sync IEEE 1588-2008 standard that allows precise synchronization of networks.
- Slave Clock** A clock that synchronizes its local clock to a master time.
- Sequence of Events (SOE)** Sequence of events is any events that must be compared against a second event.
- Synchronized Clocks** Two clocks are synchronized to a specified uncertainty if they have the same epoch and their measurements of the time of an event at an arbitrary time differ by no more than that uncertainty.
- System Time** The absolute time value as defined by CIP Sync in the context of a distributed time system where all devices have a local clock that is synchronized with a common master clock. System time is a 64-bit integer value in units of nanoseconds or microseconds with a value of 0 corresponding to an epoch of January 1, 1970.
- Time Sync Object** The time sync object provides a Common Industrial Protocol (CIP) interface to the IEEE 1588 (IEC 61588) standard for a precision clock synchronization protocol for networked measurement and control systems. This information can be collected to be used in diagnostics.
- Transparent Clocks** A device that measures the time that is taken for a PTP event message to transit the device and provides this information to clocks that receive this PTP event message.
- Coordinated Universal Time (UTC)** The time standard for 'civil time' that is time at the Prime Meridian (0° longitude). The time excludes time zone or Daylight Saving Time offsets. System time is the same as UTC.
- WallClockTime (WCT)** WallClockTime is the time of the controller, which is based on UTC system time.

Numerics

1588 Output PTP 20
1588 PTP 25
1756-TIMEK 8

A

accuracy of NTP time 32
Add-on Profile 10
amplifier
 determine if needed 50
 dummy load 50
 mounting 50
 signal gain 50

AOP

configuration parameters
 descriptions 16
 example 15

attenuation values 49

B

backplane 8
best master clock algorithm 29
BMC 29
BOOTP/DHCP server
 access 11
 download and install 11
 set IP address of module 11
boundary clock 26, 29
bulkhead connector 50

C

cable extension kits 51
clock
 master 8
 slave 8
coaxial cable 49
 attenuation 49
communication loss 32
configure the 1756HP-TIME module 12
conformal coating 8
CST 7
 master clock 16, 20
 offset 33
current time source 20

D

diagnostics 24
domain controller 29

E

Ethernet connectors 8

F

firmware
 download 12
 error 11
 revision 7

G

GPS antenna
 installation examples 9
GPS coordinates 14
GPS SMA connector 8
Grandmaster 26
Gregorian time 33

H

high-precision time synchronization 25
HSNTP 29

I

input image parameters
 description 20
 example 19
internal oscillator 32
IP packet 16
IRIG 34, 36
IRIG-B 7
 coaxial connector 8
 master clock 32
 output 20
 slave clock 32
IRIG-B-122 format 32

L

lightning protection 51
LLA 7

M

master clock 8
multicast address 26

N

NTP 7, 34, 35
 client 29
 output 20
 server 16, 29
 source 31
 version 3, RFC1305 29

O

operating modes

- GPS source 45
- IRIG-B source 46
- NTP source 47
- PTP source 46

output image parameters

- descriptions 23
- example 23

P

PTP 7, 34, 37

- as a time source 25
- output 25
- slave 29
- sync packet 16

R

RG58 coaxial cable 49

S

satellite

- GPS coordinates 14
- position 15
- signal strength 14

sequence-of-events solution 33

simulation mode 17

slave clock 8

SNTP 36

SNTP protocol 31

SOE module 33

SSV instruction 33

statistics 24

status

- indicators 41
- messages 42
- view 8

synchronization accuracy 32, 33

T

TAI 23

time

- adjustments 32
- drift 31, 32
- Grandmaster 26
- input 14
- output 14
- source 14
- sync accuracy 26
- synchronization
 - methods, standards, and protocols 7

time format conversion

- CST to Gregorian 33, 43
- CST to UTC 43
- UTC to Gregorian 33, 43

time synchronization protocol 34

transparent gateway 26

U

UTC 7

UTC offset 23, 33

W

web interface 24

Windows time service 30

Rockwell Automation Support

Use the following resources to access support information.

Technical Support Center	Knowledgebase Articles, How-to Videos, FAQs, Chat, User Forums, and Product Notification Updates.	https://rockwellautomation.custhelp.com/
Local Technical Support Phone Numbers	Locate the phone number for your country.	http://www.rockwellautomation.com/global/support/get-support-now.page
Direct Dial Codes	Find the Direct Dial Code for your product. Use the code to route your call directly to a technical support engineer.	http://www.rockwellautomation.com/global/support/direct-dial.page
Literature Library	Installation Instructions, Manuals, Brochures, and Technical Data.	http://www.rockwellautomation.com/global/literature-library/overview.page
Product Compatibility and Download Center (PCDC)	Get help determining how products interact, check features and capabilities, and find associated firmware.	http://www.rockwellautomation.com/global/support/pcdc.page

Documentation Feedback

Your comments will help us serve your documentation needs better. If you have any suggestions on how to improve this document, complete the How Are We Doing? form at http://literature.rockwellautomation.com/idc/groups/literature/documents/du/ra-du002_-en-e.pdf.

Rockwell Automation maintains current product environmental information on its website at <http://www.rockwellautomation.com/rockwellautomation/about-us/sustainability-ethics/product-environmental-compliance.page>.

Allen-Bradley, ControlFLASH, ControlLogix, Logix Designer, Logix 5000, Rockwell Automation, Rockwell Software, RSLogix, RSLogix 5000, and Studio 5000 are trademarks of Rockwell Automation, Inc.

Trademarks not belonging to Rockwell Automation are property of their respective companies.

Rockwell Otomasyon Ticaret A.Ş., Kar Plaza İş Merkezi E Blok Kat:6 34752 İçerenköy, İstanbul, Tel: +90 (216) 5698400

www.rockwellautomation.com

Power, Control and Information Solutions Headquarters

Americas: Rockwell Automation, 1201 South Second Street, Milwaukee, WI 53204-2496 USA, Tel: (1) 414.382.2000, Fax: (1) 414.382.4444

Europe/Middle East/Africa: Rockwell Automation NV, Pegasus Park, De Kleetlaan 12a, 1831 Diegem, Belgium, Tel: (32) 2 663 0600, Fax: (32) 2 663 0640

Asia Pacific: Rockwell Automation, Level 14, Core F, Cyberport 3, 100 Cyberport Road, Hong Kong, Tel: (852) 2887 4788, Fax: (852) 2508 1846

Publication 1756-UM542B-EN-P - March 2017

Supersedes Publication 1756-UM542A-EN-P - September 2014

Copyright © 2017 Rockwell Automation, Inc. All rights reserved. Printed in the U.S.A.