

DESCRIPTION

The LT-SP Power End Termination Kit is for use with all versions of Nelson Heat Tracing Systems' LT & CLT heater cables except for J option. Minimum installation temperature -30°C (-22°F).

KIT CONTENTS

- 5 Shrink Tubes, 13mm (0.5") diameter, 51mm (2") length
- 10 Shrink Tubes, 3mm (0.125") diameter, 25mm (1") length

OVERJACKET STRIPPING PROCEDURES

Proceed to step 4 for Braided Products.

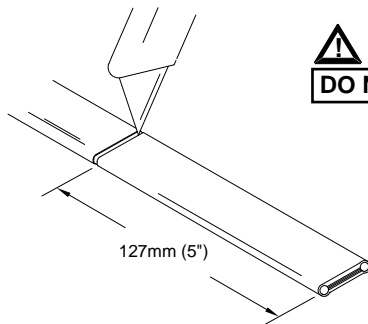

WARNING:
DO NOT CUT BRAID

- 1 Lightly cut around heater overjacket 127mm (5") from the end. Bend cable to break the overjacket.
- 2 Lightly cut overjacket up the center between first cut mark and the cable end. Bend cable to break outer jacket.

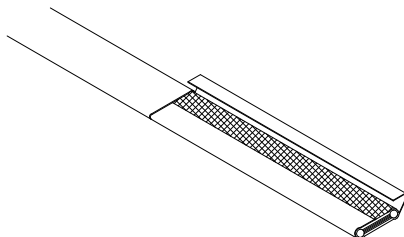

- 3 Remove overjacket from heater cable.

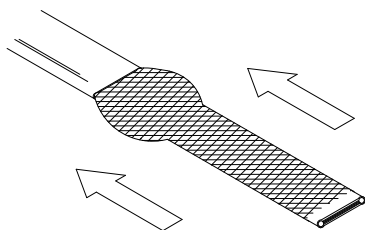

- 4 Move braid back toward the overhacket, creating a bulge.

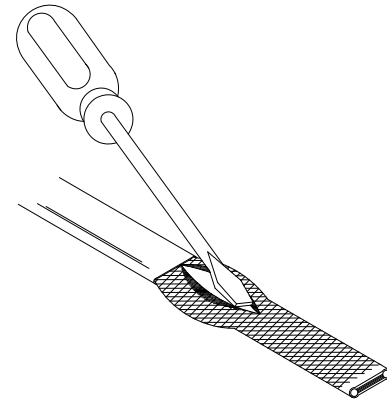

- 5 At the bulge, separate the braid to make an opening.

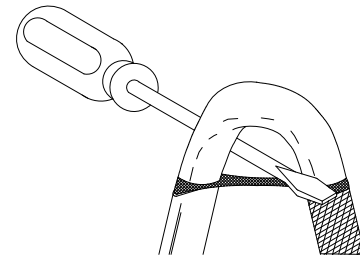

- 6 While bending the heater cable, work it through the braid opening.

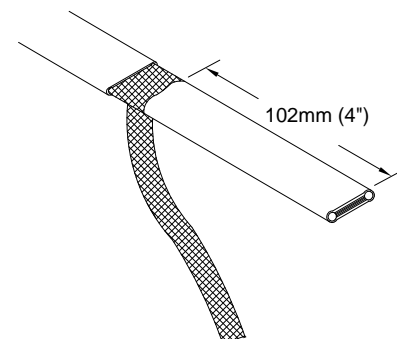

- 7 Pull braid tight.
- 8 Repeat steps 1 - 7 for both heater cables.
- 9 Proceed to "Outer Jacket Stripping Procedures", sheet 2.

OUTER JACKET STRIPPING PROCEDURES

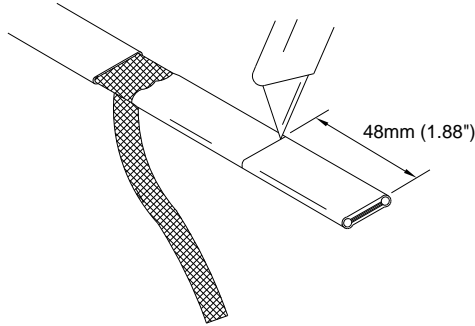

- 1 Lightly cut around heater outer jacket 48mm (1.88") from the end. Bend cable to break outer jacket.
- 2 Lightly cut the outer jacket up the center between the first cut mark & the cable end. Bend cable to break outer jacket.

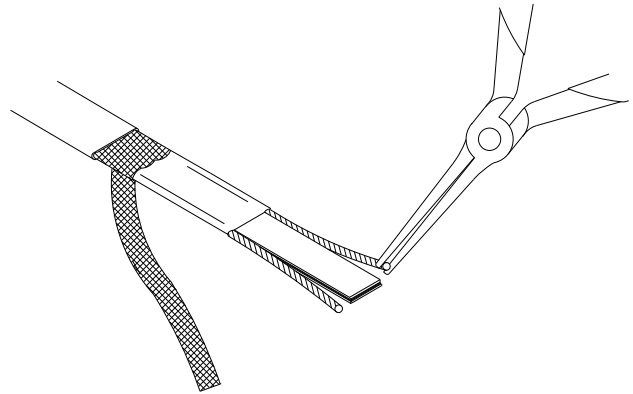

- 5 Starting at the end, pull each bus wire away from the core material.
- 6 Remove exposed core material.

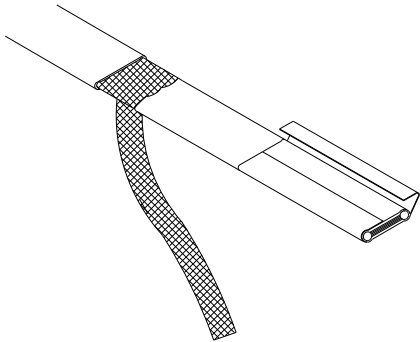

- 3 Remove jacket from the heater cable.

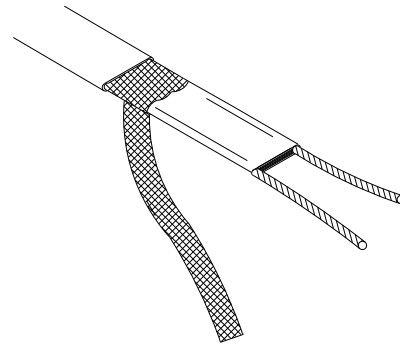

- 7 Repeat steps 1 - 6 for both heater cables.
- 8 Proceed to "Shrink Tube Procedures", sheet 3

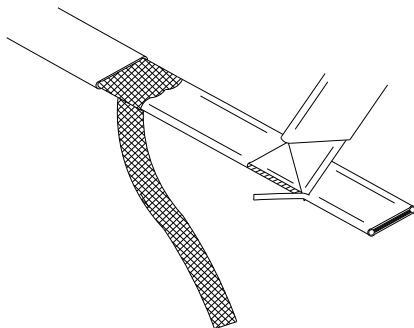

⚠ WARNING:
DO NOT CUT BUS WIRES

- 4 Shave core material from the outside of each bus wire.

SHRINK TUBE PROCEDURES

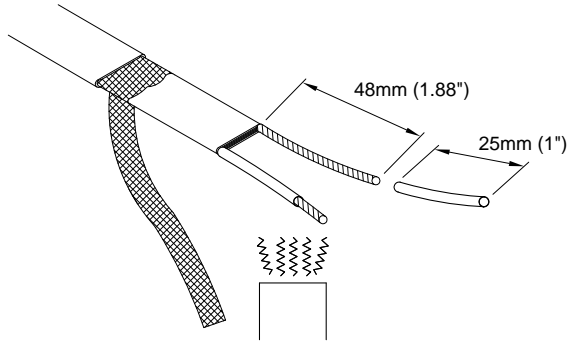

- 1 Slide one 3mm (0.125") diameter, 25mm (1") length shrink tube over each bus wire leaving approximately 13mm (0.5") of each bus wire exposed. Shrink with heat gun until completely shrunk.

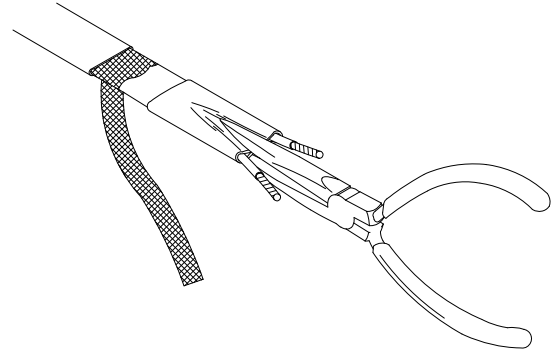

- 3 While still warm, spread bus wires and squeeze between them using needle-nose pliers, hold for 5 seconds. Allow power termination to cool before use.

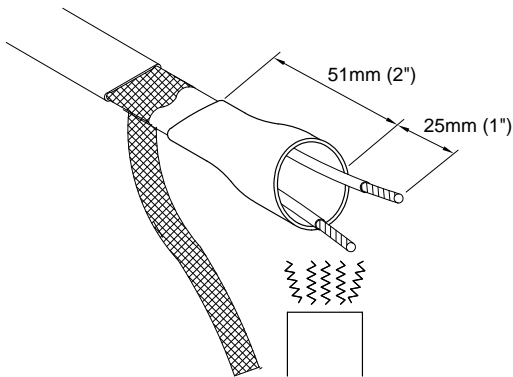

- 2 Slide one 13mm (0.5") diameter, 51mm (2") length shrink tube over both pigtail leads leaving approximately 25mm (1") of each pigtail lead exposed. Shrink with heat gun until completely shrunk.

NELSON™ HEAT TRACING SYSTEMS

LT-SP POWER END TERMINATION KIT

**INSTALLATION
INSTRUCTIONS**