

Part #500615-001

Product Manual:

Model #TFAT-11A
Telescopic Fall Arrest Tower

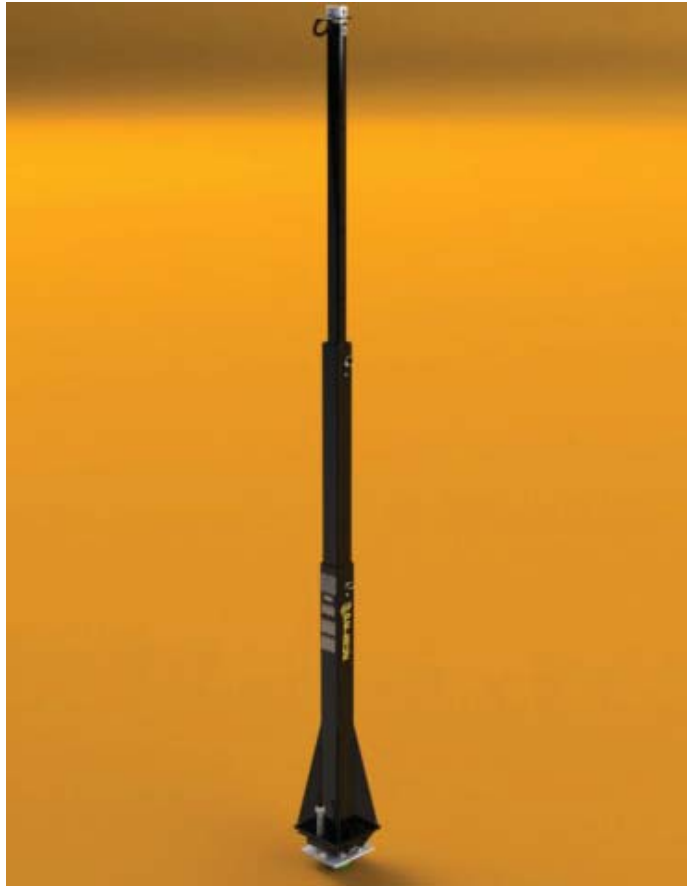

PELSUE[®]
ISO 9001 Certified

T.A. Pelsue Company
2500 South Tejon Street
Englewood, Colorado, USA 80110
Tel. 800-525-8460 or 303-936-7432
Fax. 303-934-5581
Internet: www.pelsue.com
Email: sales@pelsue.com

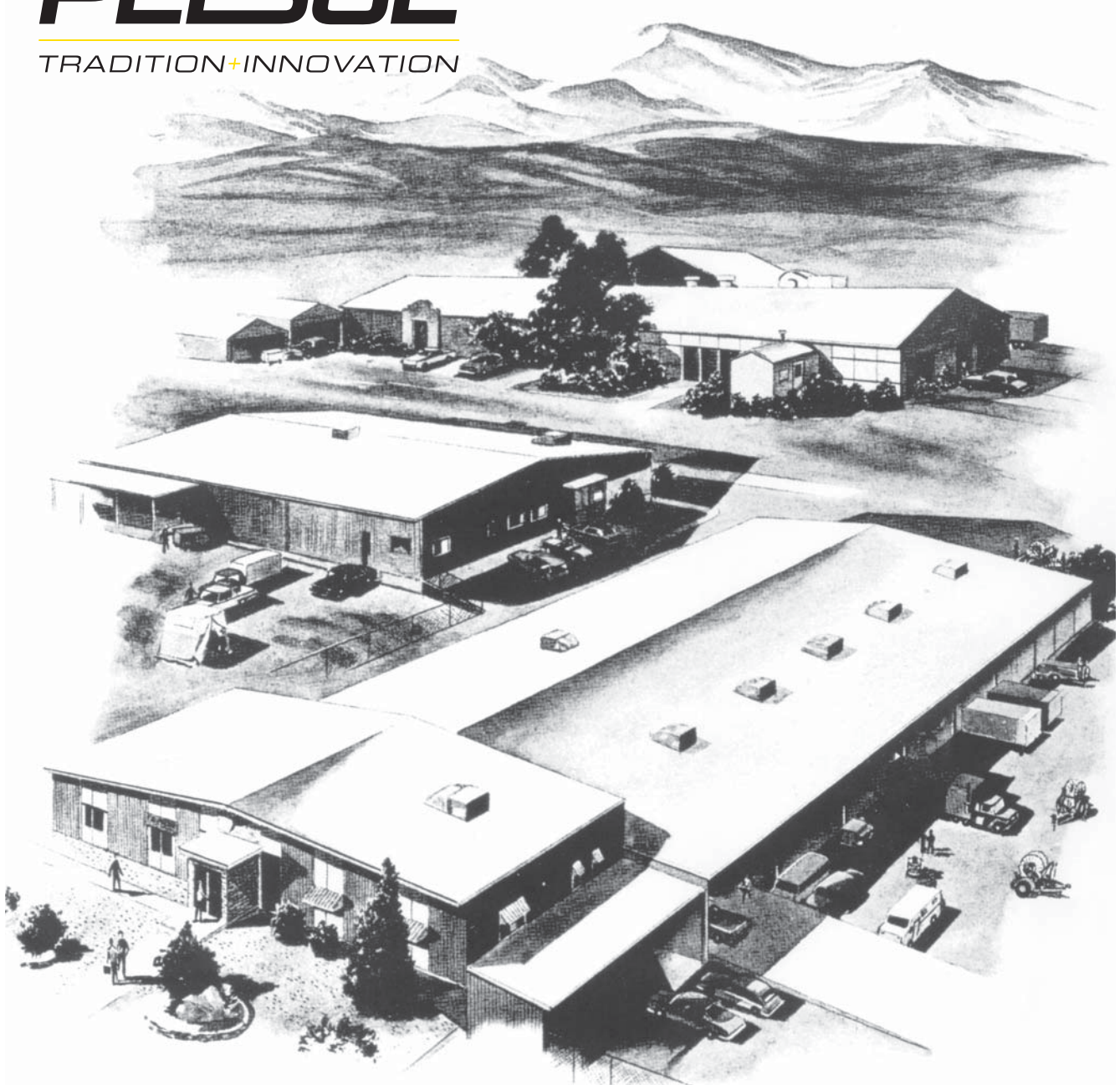

Since our inception in 1963 – the T.A. Pelsue Company has designed and manufactured high quality equipment to improve the personnel efficiency and working conditions in various underground, confined, and outdoor areas.

Founded by T. Allen Pelsue, the company has established a continuing reputation for excellence in the production of fine products for a broad spectrum of industry throughout the world.

Now, in our second generation of family direction, continued commitment to innovation and quality makes Pelsue a leading source of equipment for many types of confined spaces. We specialize in safety, retrieval, fall arrest, ventilation, cable placing, splicing, and maintenance nationally and abroad. With more than 70,000 square feet of facilities available, Pelsue continues the dedication that has made us pre-eminent in this field.

Table of Contents

| Section | Description | Page # |
|----------------|---|---------------|
| 1.0 | General Information | 5 |
| 1.1 | Quality Policy | |
| 1.2 | Pelsue Product Warranty | |
| 2.0 | Introduction & Product Information | 7 |
| 2.1 | Serial Number | |
| 3.0 | Configuration & Assembly | 8 |
| 3.1 | Label Locations | |
| 4.0 | Safety | 10 |
| 4.1 | Warning Statement | |
| 4.2 | Safety Alert Symbol | |
| 4.3 | General Safety Information | |
| 4.4 | Operating Safety | |
| 4.5 | Maintenance Safety | |
| 4.6 | New Operator Safety Information | |
| 5.0 | Product Operation | 13 |
| 5.1 | Product Description & Capabilities | |
| 5.2 | Product Installation & Set-Up | |
| 6.0 | Maintenance & Inspection | 18 |
| 6.1 | Maintenance | |
| 6.2 | Inspection | |
| 6.3 | Inspection Log | |
| 7.0 | Storage | 22 |
| 8.0 | Contact Information | 22 |

T.A. Pelsue Company

Quality Policy

OUR GOAL IS THE PURSUIT OF NEVER-ENDING IMPROVEMENT IN PRODUCT QUALITY AND BUSINESS SYSTEMS.

METHODS TO BE EMPLOYED IN ATTAINING THIS GOAL WILL INCLUDE NEW PRODUCT QUALITY PLANNING, EMPLOYEE TRAINING, AND UTILIZATION OF EMPLOYEE INVOLVEMENT GROUPS TO SOLVE PROBLEMS.

IN AN INCREASINGLY COMPETITIVE MARKETPLACE, ENSURING CUSTOMER SATISFACTION IS ONE OF THE DIFFERENTIATORS THAT SETS YOU APART FROM THE PACK AND YIELDS A COMPETITIVE ADVANTAGE.

THEREFORE, WE WILL SUPPORT TOTAL CUSTOMER SATISFACTION BY IMPLEMENTING THE **ISO 9001 QUALITY SYSTEM** AND PROVIDING THE NECESSARY ATMOSPHERE AND TRAINING TO NURTURE THIS CONCEPT THROUGHOUT OUR ORGANIZATION.

WE WILL MAKE EVERY BUSINESS DECISION AS THOUGH THE QUALITY OF THE PART OR SERVICE PROVIDED WAS DESTINED FOR OUR OWN OR OUR FAMILY'S USE. WE WILL ALWAYS THINK **QUALITY FIRST**.

EVERY T.A. PELSUE COMPANY EMPLOYEE IS EXPECTED TO COMMIT TO THIS PHILOSOPHY IN THE PERFORMANCE OF HIS OR HER DAILY TASKS.

QUALITY FIRST!

T.A. PELSUE COMPANY SENIOR MANAGEMENT TEAM

1.2 - Pelsue Product Warranty

Pelsue products are designed and engineered to perform as stated in published specifications. Quality materials and workmanship are used in the manufacture of this product. With regular maintenance and proper care, Pelsue equipment provides many trouble free hours of operation.

The T.A. Pelsue Company warrants to the buyer that the Hoist Product furnished will conform to specifications and will be free from defects in material and workmanship from the date of shipment to the original buyer, for a period of 1 year (12 months). In the event of failure of any components of a Pelsue product within the warranty period, service must be pre-approved by the T.A. Pelsue Company, and service must be performed by the T.A. Pelsue Parts and Service Department in Englewood, Colorado, or at the option of the T.A. Pelsue Company, service may be performed at any designated service center, which may include any authorized service center for the component manufacturer. Unauthorized repairs will not be covered by this warranty.

Damage or failure due to misuse, mishandling, or unauthorized modifications will not be covered by this warranty. Unless otherwise agreed, the T.A. Pelsue Company shall repair or replace the defective components within (30) calendar days of notice of failure. T.A. Pelsue Company's obligation hereunder, shall be limited to the repair or replacement of the product or component as set forth above and shall not include any liability whatsoever for damages caused by such failure, including, but not limited to consequential or incidental damages flowing from use or lack of use of product.

Any replacement, repair, modification, installation, or other service performed by the T.A. Pelsue Company shall be warranted by the remainder of the unexpired period of the warranty, or for a period of (90) calendar days, whichever is longer.

All materials or parts returned for credit or warranty shall be returned only with prior approval, and will be subject to factory inspection before credit is allowed. Parts claimed defective will be replaced upon request and will be invoiced as purchased, subject to credit when the parts claimed to be defective have been received and examined by the factory.

This warranty is expressly in lieu of all other warranties expressed or implied, including any warranties of merchantability or warranties of fitness for any particular use and all other obligations or liabilities in connection with the sale of this equipment.

T.A. Pelsue Company, 2500 South Tejon Street, Englewood, Colorado 80110, 800-525-8460

2.0 - Introduction & Product Information

Congratulations on your choice of a **Pelsue Model #TFAT-11A Telescopic Fall Arrest Tower** to compliment your complete fall arrest system. This equipment has been designed and manufactured to exceed fall arrest requirements and regulations in order to meet the needs of the discriminating operator for the efficient and safe working conditions of personnel at height.

Safe, efficient and trouble-free operation and maintenance of the system requires that anyone who will be operating, maintaining, or inspecting the equipment, read, understand and follow all of the operation, safety, maintenance, and inspection instructions contained within this manual. This manual covers the Pelsue Model #TFAT-11A Telescopic Fall Arrest Tower. Use the Table of Contents as a guide to find specific information.

Keep this manual available for future reference and for usage as a tool in the instruction of new operators. Establish a regular training program for all operators. Establish a regular maintenance and inspection program to keep the equipment in top condition.

WARNING

This product is a part of a complete Fall Arrest System. The user must read, understand and follow the instructions contained in this manual and for each component of the total system before using this equipment. Establish an appropriate training, maintenance and inspection program for approved users and the equipment itself. Failure to follow these instructions could result in serious injury or death.

2.1 - Serial Number

Product Serial Number

Always give your dealer the serial number of your Pelsue Fall Arrest product when ordering parts or requesting service or other information.

The serial number label is permanently embossed with a serial number. The serial number decal will appear as shown in *Figure 2a* at the right and is located on the lower portion of the tower (see *Figure 2b*). A space has been provided below for the recording of the serial number for future reference.

MODEL: **#TFAT-11A** _____

Serial Number : _____

Date of Manufacture (DOM): _____

| |
|--------------|
| S/N# _____ |
| MODEL# _____ |
| DOM _____ |

Figure 2a:
Serial Number Label

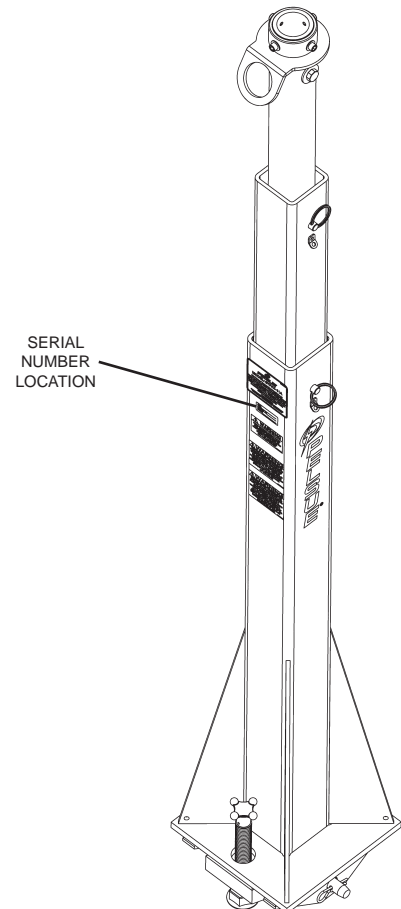

Figure 2b:
Serial Number Decal Location

3.0 - Configuration & Assembly

Upon initial receipt of the #TFAT-11A system inspect the packaging for any evidence that the product may have been damaged in shipment. While unpacking the product, inspect all of the components for damage. If damage to any of the components is discovered, DO NOT USE THE PRODUCT! Alert the shipping carrier immediately of the damage to the shipment.



UPPER TOWER ASSEMBLY:
#500561-001

| UPPER TOWER ASSEMBLY | | 500561-001 |
|----------------------|------------|-------------------------------|
| ITEM# | PART# | DESCRIPTION |
| 1. | 121569-001 | Screw - socket head, SS |
| 2. | 118283-002 | Washer - Flat, 5/16", SS |
| 3. | 100049-015 | Screw - Cap, 1/2-13, plated |
| 4. | 100050-013 | Washer - Flat, 1/2", plated |
| 5. | 107944-001 | Nut - Stover, 1/2"-13, plated |

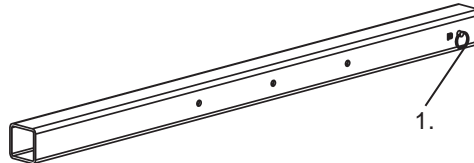
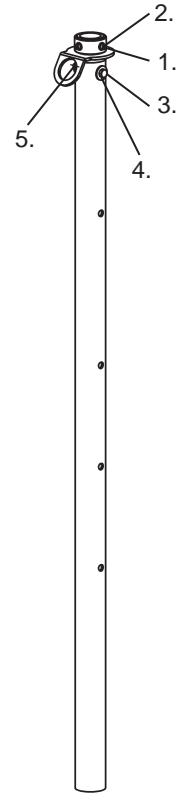

MID TOWER ASSEMBLY:
#500562-001

| MID TOWER ASSEMBLY | | 500562-001 |
|--------------------|------------|-----------------------------|
| ITEM# | PART# | DESCRIPTION |
| 1. | 500408-005 | Pin & Lanyard - 1/2" x 3.8" |



| LOWER TOWER ASSEMBLY | | 500563-001 |
|----------------------|------------|-----------------------------|
| ITEM# | PART# | DESCRIPTION |
| 1. | 500565-001 | Screw Peg Assembly - 1"-8 |
| 2. | 500551-001 | Pin - Hitch, 3/4" x 8-1/2" |
| 3. | 500408-001 | Pin & Lanyard - 1/2" x 4.5" |

LOWER TOWER ASSEMBLY:
#500563-001

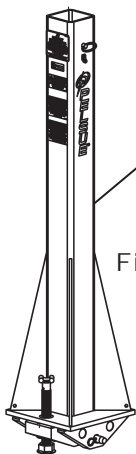
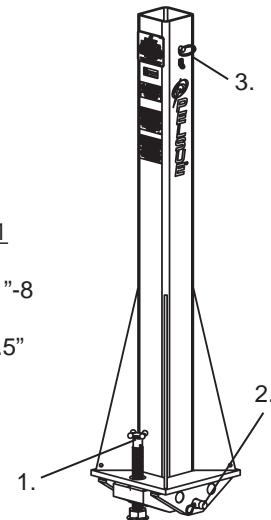

Figure 3.1: #TFAT-11A
Diagram & Parts List

Verify that all parts are present before use.

The #TFAT-11A is normally shipped fully assembled.

In some isolated cases, the three main tower assemblies may be separated for shipping purposes. If this is the case, all three assemblies must be joined prior to operation. The three assemblies are joined by simply sling each smaller tube inside of the next largest tube and then using the attached pins to secure the sections in place.

**Refer to parts list above if replacement parts are required. Replacement parts can be ordered from the T.A. Pelsue Company at 800-525-8460.

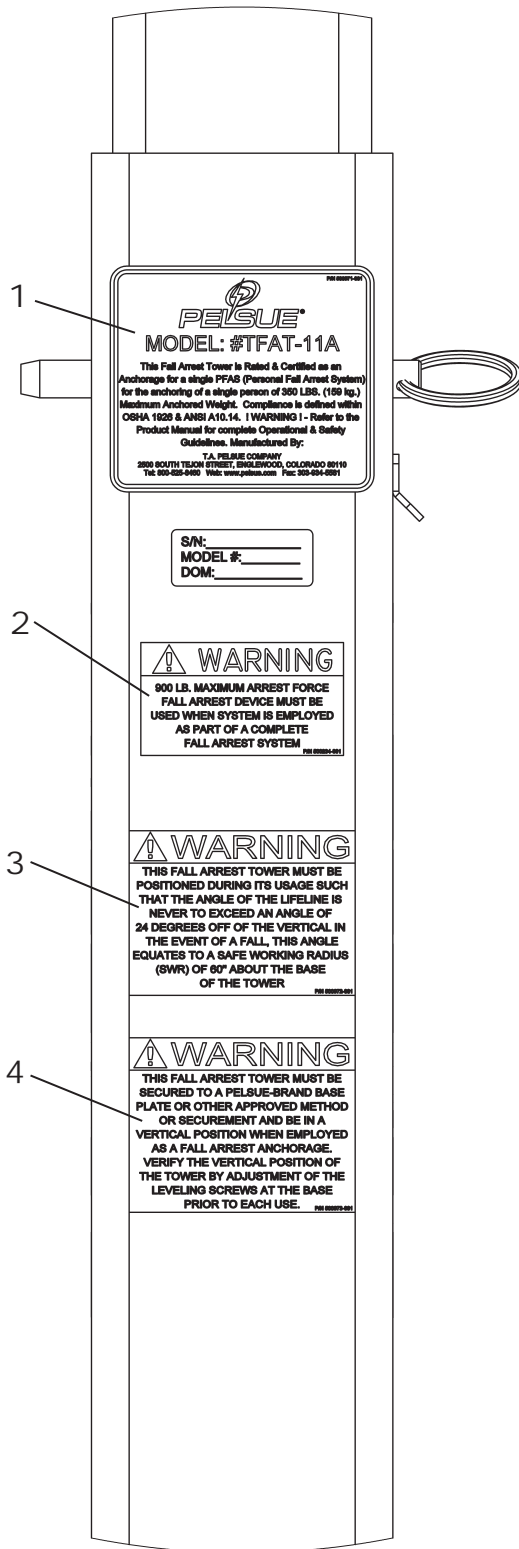
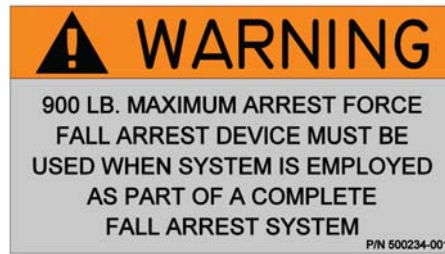

Figure 3.1: #TFAT-11A Label Locations



1) 500971-001



2) 500234-001



3) 500972-001

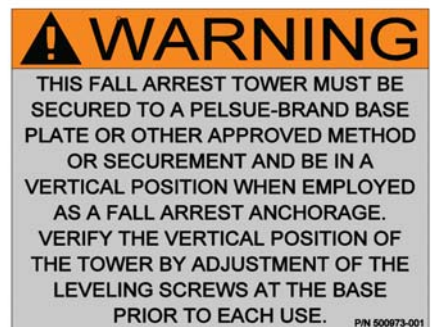

4) 500973-001

4.0 - Safety

The following section will address the safety precautions which must be adhered to when working with Pelsue Elevated Fall Arrest Safety equipment such as the #TFAT-11A Telescopic Fall Arrest Tower. Any user must familiarize themselves with the information in this section before utilizing the equipment.

SIGNAL WORDS:

Note the use of the signal words **DANGER**, **WARNING** and **CAUTION** with the safety messages. The appropriate signal word for each message has been selected using the following guidelines:

- DANGER-** Indicates an imminently hazardous situation that, if not avoided, will result in death or serious injury. This signal word is to be limited to the most extreme situations or for hidden or unseen hazards.
- WARNING-** Indicates a potentially hazardous situation that, if not avoided, could result in death or serious injury and includes obvious and hidden hazards. It may also be used to alert against unsafe practices.
- CAUTION-** Indicates a potentially hazardous situation that, if not avoided, may result in minor or moderate injury. It may also be used to alert against unsafe practices.

You are responsible for the safe operation, maintenance and inspection of your Pelsue #TFAT-11A Telescopic Fall Arrest Tower. You must ensure that anyone who will operate, maintain, inspect or work around the equipment be familiar with the operating and maintenance procedures and related safety information contained in this manual. This manual will take you step-by-step through the workings and capabilities of the #TFAT-11A Telescopic Fall Arrest Tower and alert you to all good safety and operating practices while using the system.

Remember, you are the key to safety. Good safety practices not only protect you but also the people around you. Make these practices a working part of your safety program. Be certain that everyone operating this equipment is familiar with the procedures recommended and follows safety precautions. Remember, most accidents can be prevented. Do not risk injury or death by ignoring good safety practices.

- System owners must give operating instructions to operators or employees before allowing them to use the equipment and at least annually thereafter.
- The most important safety device on this equipment is a safe operator. It is the operator's responsibility to read and understand all safety and operating instructions in the manual and to follow these. Most accidents can be avoided.
- A person must understand the operation of this equipment and be trained in it's usage before operating the equipment. An untrained operator exposes himself and others to possible serious injury or death.
- Do not modify the equipment in any way. Unauthorized modification may impair the function and/or safety and could affect the life of the equipment.
- Think SAFETY! Work SAFELY!

4.1 - Warning Statement

WARNING!

Products manufactured or sold by the T.A. Pelsue Company are intended for use by professionals trained and experienced in the use, inspection and maintenance of these products.

Paraprofessional users such as volunteer rescue workers and sportsmen involved in risk sports such as climbing and caving will be held to the same standard of experience and training as professionals.

Technical rescue, repelling, climbing and the training involved are hazardous activities. Each situation has its own unique conditions and must be evaluated. Effective risk management comes from experience, proper training and good personal judgement.



SAFETY ALERT SYMBOL

This Safety Alert symbol means **ATTENTION! BECOME ALERT! YOUR SAFETY IS INVOLVED!**

The Safety Alert symbol identifies important safety messages on your Pelsue Retrieval Product and in the manual. When you see this symbol, be alert to the possibility of personal injury or death. Follow the instruction in the safety message.



Why is this symbol important to you?

- 3 BIG Reasons:**
- Accidents Disable and Kill.**
 - Accidents Cost You Money.**
 - Accidents Can Be Avoided.**

4.3 - General Safety Information

1. Read, understand, and follow the Product Manual and all safety signs before using, maintaining or inspecting the equipment.
2. Refer to and follow applicable standards and regulations. Comply with requirements of local regulations for your applications.
3. Establish an equipment-use training program for inexperienced employees. Only trained, competent persons shall use the equipment. An untrained operator is not qualified to operate the system.
4. Have a first-aid kit available for use should the need arise and know how to use it.
5. Provide a fire extinguisher for use in case of an accident. Store in a highly visible place.
6. Install and properly secure all guards and shields before operating.
7. Wear appropriate protective gear. This list includes but is not limited to:
 - A hard hat
 - Protective shoes with slip resistant soles
 - Heavy gloves
 - Protective clothing
 - Face Protection
8. Review and follow the Pre-Operation Checklist before using a component in the system or system itself.
9. Establish a regular maintenance and inspection program with your equipment and maintain detailed records.
10. Review safety related items and operating instructions with all personnel on a regular basis.

4.4 - Operating Safety

1. Read, understand and follow the Product Manual as well as all printed warnings that may be located on the product itself before using, maintaining or inspecting the equipment.
2. Train all operators before allowing them to use the product. An untrained operator exposes themselves, bystanders and workers to possible serious injury or death.
3. Visually inspect the product and all auxiliary components and equipment before using. Correct any problems before using the equipment.
4. Securely anchor the product before using.
5. Use only certified anchor and connector components in your system.
6. Use only an approved full body harness for the workers.

4.4 - Operating Safety (continued)

7. Always work in teams. When working upon an elevated surface where a fall is possible, making a subsequent rescue necessary, personnel must be available and ready for rescue immediately. Working alone with this equipment is inherently dangerous and not advised!
8. Do not exceed the capacity & capabilities of the system at any time (see section 5.1).
9. Establish a regular training program for all operators and potential rescuers.
10. Establish a detailed inspection program for your equipment and document the findings. Return the equipment to the manufacturer for repair if any problems are found.
11. Plan your work program before starting. Have the required people, equipment and procedures readily available in order to safely complete any task prior to commencing.
12. Do not use the equipment around physical or environmental hazards. This list includes but is not limited to:
 - Corrosion that may affect the structural integrity of the lifeline or other components.
 - Chemicals which can degrade components in a manner which can not be visually identified.
 - Toxic gases: Rescuers or workers can be killed in toxic environments.
 - Heat or elevated temperatures.
 - Moving machinery: Workers or auxiliary equipment can be contacted by or pulled into moving components.
 - Sharp edges: Workers or the rescue equipment can be injured by or damaged by sharp edges or components.
 - Electrical hazards: Stay away from power lines or components carrying electrical power.
 - Overload: Do not overload the system at any time during operation (see section 5.1).
 - Follow elevated work area and fall protection regulations and standards.

4.5 - Maintenance Safety

1. Read, understand and follow the Product Manual as well as any printed warnings that may be present on the product before using, maintaining or inspecting the equipment.
2. ANSI and OSHA require a regular inspection program for all fall arrest equipment as well as properly-documented results of the inspections. Follow the inspection procedures contained in this manual and use the inspection form to document the results (see section 6.0).
3. Keep instructional and safety signs clean and legible at all times. Clean or replace as required.
4. Remove the equipment from service if a problem is found during the inspection. Return to an authorized repair depot or the factory for service.

4.6 - New Operator or Owner

The Pelsue Model #TFAT-11A Telescopic Fall Arrest Tower is designed to provide a single elevated fall arrest system anchor point. Every new operator must read, understand and follow the instructions in this Product Manual. No person should be permitted to use the equipment without prior proper training. The training should be reviewed with experienced operators on a regular basis. At regular intervals, perform a detailed inspection of the equipment and document the results. Remove the product from service if any deficiencies are found. Alterations or misuse of this equipment or failure to follow instructions may result in serious injury or death.

It is the responsibility of the owner's organization to ensure that the proper training is provided to all operators of any fall arrest device before they start working with the equipment. Follow all safety instructions exactly. Safety is everyone's business. By following recommended procedures, a safe working environment is provided for the operator, bystanders and the area around the work site. Untrained operators are not qualified to operate the equipment.

Many features incorporated into this equipment are the result of suggestions made by customers like you. Read this manual carefully to learn how to operate & install the equipment safely and as intended. By following the operating instructions in conjunction with a good maintenance program, your product will provide many years of trouble free service.

5.0 - Product Operation

The following section will address the capabilities and the general operation of the Pelsue #TFAT-11A Telescopic Fall Arrest Tower. The instructions contained within this section should be adhered to each and every time the product is used. Any person tasked with installing or operating this piece of equipment should be familiar with these procedures.

5.1 - Product Description & Capabilities

The Pelsue #TFAT-11A Telescopic Fall Arrest Tower is constructed of structural aluminium and incorporates several steel components. The #TFAT-11A fall arrest tower can be extended and secured in several positions providing an elevated anchorage for a single personal fall arrest system. The #TFAT-11A's maximum attainable anchorage height is approximately 11' from the working surface when. All specifications, instructions, and procedures provided within this manual or upon Pelsue Specification Documents are based upon and only valid for usage with Pelsue-manufactured and approved mounting bases. The T.A. Pelsue Company can not verify equipment safety and/or compliance when utilized with anything other than Pelsue approved bases and accessories.

Telescopic Fall Arrest Tower - #TFAT-11A

General Specifications

- Safe Working Radius @ Tower Base- 5' (60")
- Structure Weight - 75 lbs.
- Tower Heights - Maximum Height - 11' - 0"
Minimum Height - 6' - 6"

Load Capacity

- Single user with a maximum weight of 350 lb. with a safe working radius of 5' @ Tower Base
- Refer to loading diagrams for proof loads.

Materials & Construction

- Welded Aluminum

Features:

- Easily installs adjacent to elevated work stations requiring access.
- Provides an elevated fall arrest anchor point
- Constructed primarily of lightweight & corrosion-resistant powder coated aluminum



! WARNING ! - The user must ensure that the two sectional locking pins located on the tower structure are set in one of the allowable positions and that the pin securing the tower system to its base plate is locked in place in order to retain the stated compliance of the entire system.

! WARNING ! - Any lifeline connection made to the #TFAT-11A system must be made in conjunction with a 900 LB. MAF fall arrest device. Failure to do so can result in serious injury or even death.

! WARNING ! - The user must ensure that the structure to which the tower base is installed is capable of withstanding the weight of the system combined with the system proof loads in order to retain the stated compliance of the entire system.

! WARNING ! - The user must ensure that the tower system is properly installed & completely vertical in order to retain the stated compliance and stability of the entire system.

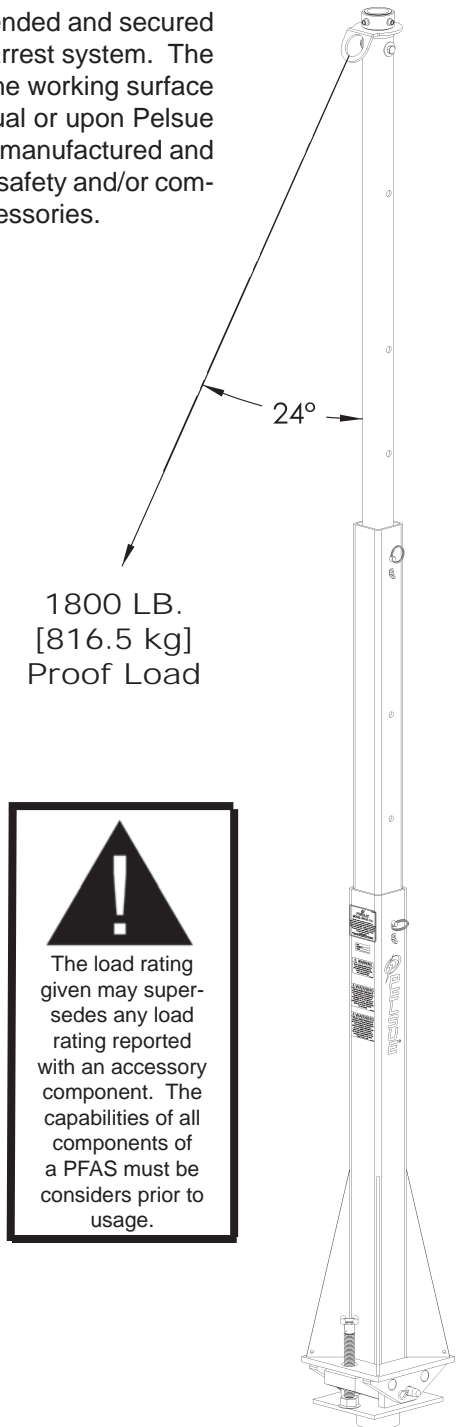
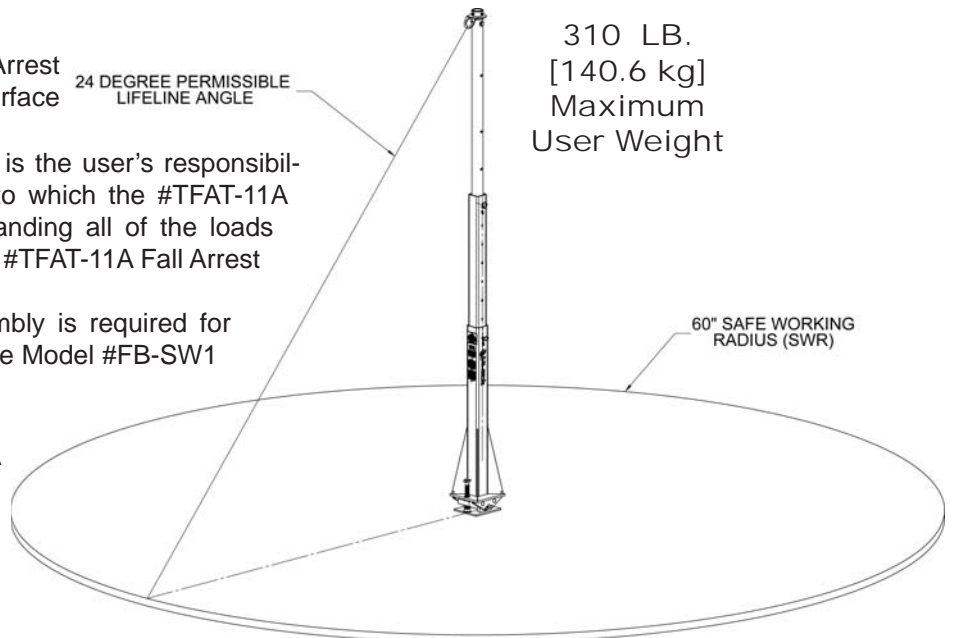

Figure #5.1a: Loading Diagram TFAT-11A

5.1 - Product Description & Capabilities (continued)

Additional Requirements & Notes:

- The #TFAT-11A Series Fall Arrest Tower must be set on a level surface and made vertical prior to use.
- In order to ensure compliance, it is the user's responsibility to ensure that the structure to which the #TFAT-11A is attached is capable of withstanding all of the loads imparted to it by the proof-loaded #TFAT-11A Fall Arrest Tower.
- An approved Pelsue base assembly is required for operation & installation (i.e. Pelsue Model #FB-SW1 Base Plate).
- Any single user lifeline connection made to the Model #TFAT-11A tower system must be made utilizing a 900 LB. MAF (Maximum Arrest Force) device integrated into the lifeline.



! WARNING ! - Any lifeline connection made to the #TFAT-11A system must be made in conjunction with a 900 LB. MAF fall arrest device. Failure to do so can result in serious injury or even death.

Figure #5.1b: #TFAT-11A safe working radius

5.2 - Product Installation & Set-up

Prior to Operation, the #TFAT-11A Telescopic Fall Arrest Tower must be configured and prepared according to the following guidelines.

1. Pre-Operation Inspection:

It is necessary to perform a visual inspection prior to each time using the product. If deficiencies are found, remove the product from service and contact the T.A. Pelsue regarding repair. The following checklist coupled with *Figure #5.2a* should be used as a guide to determine whether the equipment is in good operating condition prior to usage. Equipment that is not in good condition can endanger the safety of the user and nearby workers.

The Pre-Operation Visual Inspection is not limited to, but must include the following items;

- a. Check that the product has no structural defects, such as dents, bends, cracks, or fractures.
- b. Ensure that all product rating & warning labels are clear and legible.
- c. Check that the sections slide smoothly in and out of each other (Binding can be indicative of other damage).
- d. Ensure that the swivel anchor point rotates freely about the tower and does not appear damaged.
- e. All hardware (Pins, Leveling Screws) have not been damaged and are in working condition.

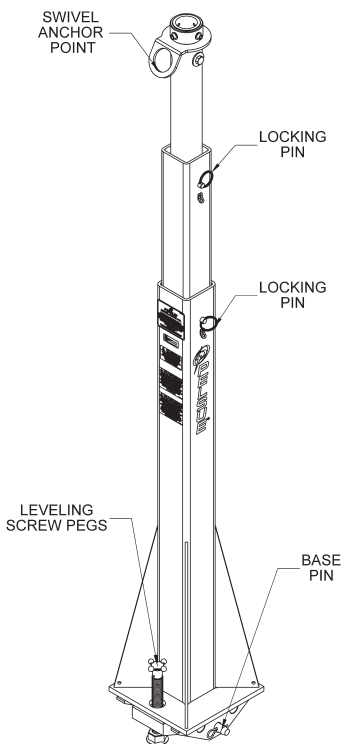

! WARNING ! - A pre-operation inspection is required each time the product is to be installed or utilized as a connection point.

Figure #5.2a: #TFAT-11A Pre-Operation Inspection Points

5.2 - Product Installation & Set-up (continued)

2. Setup of the #TFAT-11A Telescopic Fall Arrest Tower:

Choose a location where installation will provide suitable proximity to the work area yet minimize obstructions during use and in the event a rescue is necessary. Once a location is chosen;

- a. Align the holes in the tower base with the holes of the base plate "ears" and insert the base's pin in order to secure the tower to the base plate (Refer to Fig. #5.2b).
- b. Plumb the #TFAT-11A using the levelling pegs (Refer to Fig. #5.2c) so that the structure is vertical and perpendicular to the intended working surface.

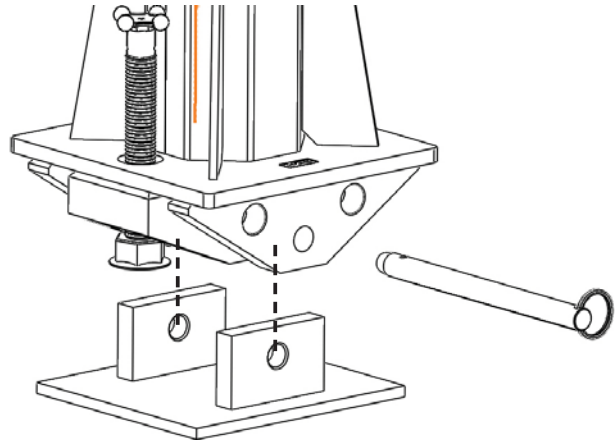
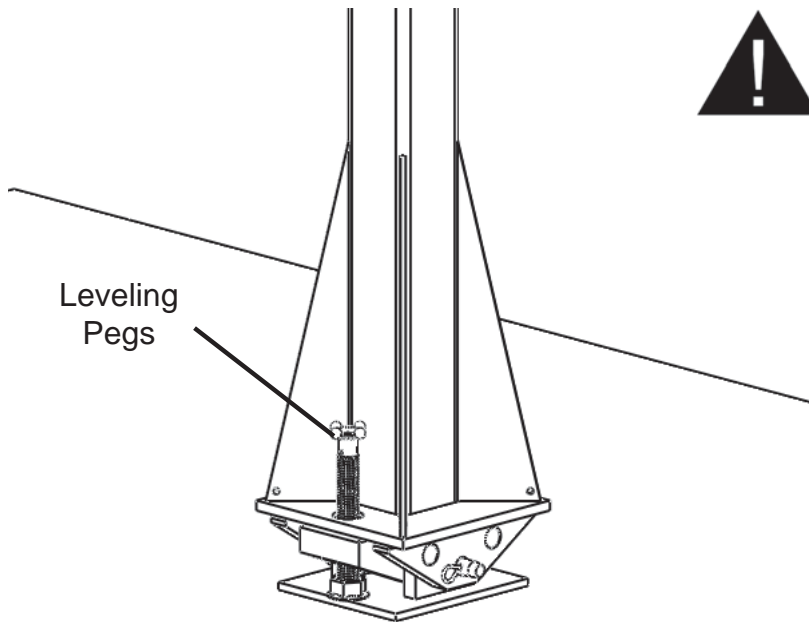

Figure #5.2b: #TFAT-11A Base Pin



! WARNING ! - Ensure that the mounting structure will withstand all loads imparted to it by the proof-loaded #TFAT-11A tower system



! WARNING ! The Model #TFAT-11A must be positioned so that the lifeline angle will not exceed 24 degrees off of the vertical in the event that a fall occurs.

Figure #5.2c: #TFAT-11A Tower Vertical and Secured to Structure



! WARNING ! - The Model #TFAT-11A must be plumbed vertically prior to the attachment of any lifeline. The #TFAT-11A is only approved for lifeline attachment when mounted vertically

5.2 - Product Installation & Set-up (continued)

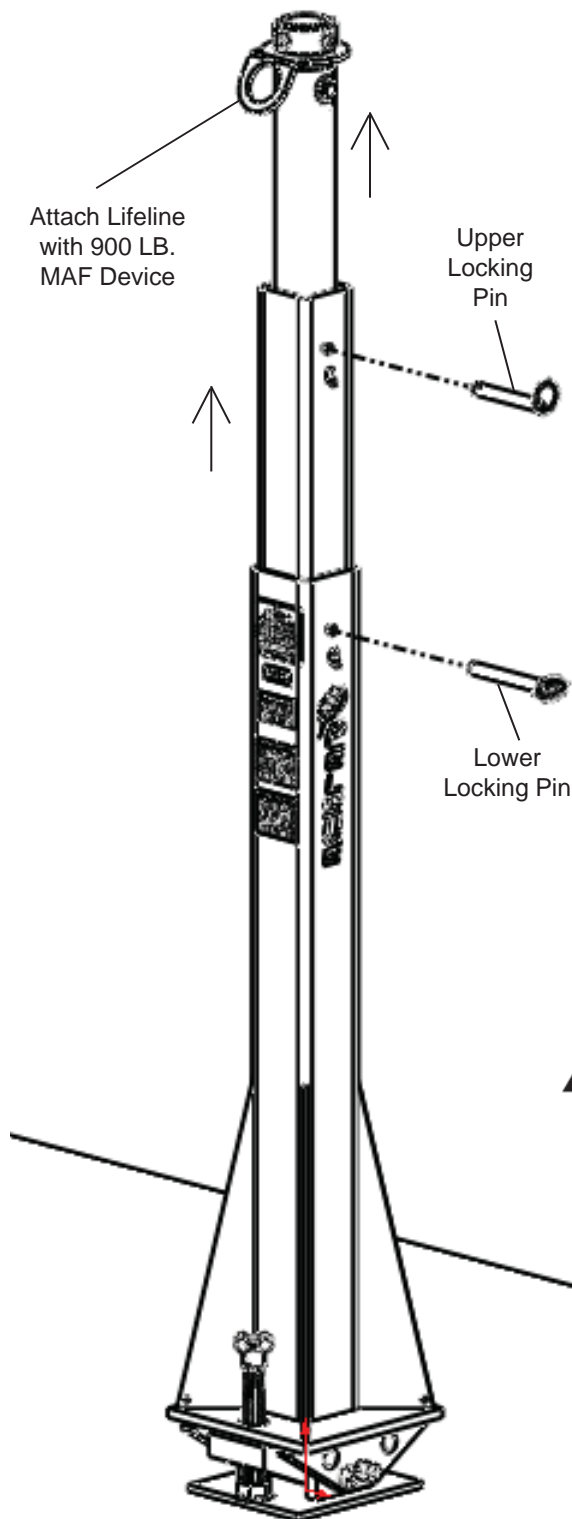

- c. A single lifeline may now be attached to the swivel tie-off ring located at the top of the tower. Only a single lifeline may be attached to the top of the tower at any one. Any attached lifeline must be equipped with a 900 LB. MAF (Maximum Arrest Force) Fall Arrest Device.**
- d. The #TFAT-11A can now be extended and secured to any of its possible positions for usage. To extend the tower to its maximum height, remove the upper securing pin from the tower and grasp the upper (round) tub with both hands. The upper tube can then be lifted to its upper most position and then the locking pin re inserted thereby locking the upper assembly in place. Next, remove the lower locking pin and grasp the middle (square) tube with both hands and then lift to its highest position, then reinsert the locking pin.

**NOTE: It will likely be easier to attach the lifeline/SRL to the tower's anchorage point prior to elevating the system to its desired position.

! DANGER !

The #TFAT-11A is only rated for a single user. Ensure that all equipment utilized within the complete PFAS (personal fall arrest system) is rated and certified for the application.

Figure #5.2d: Tower Extension

5.2 - Product Installation & Set-up (continued)

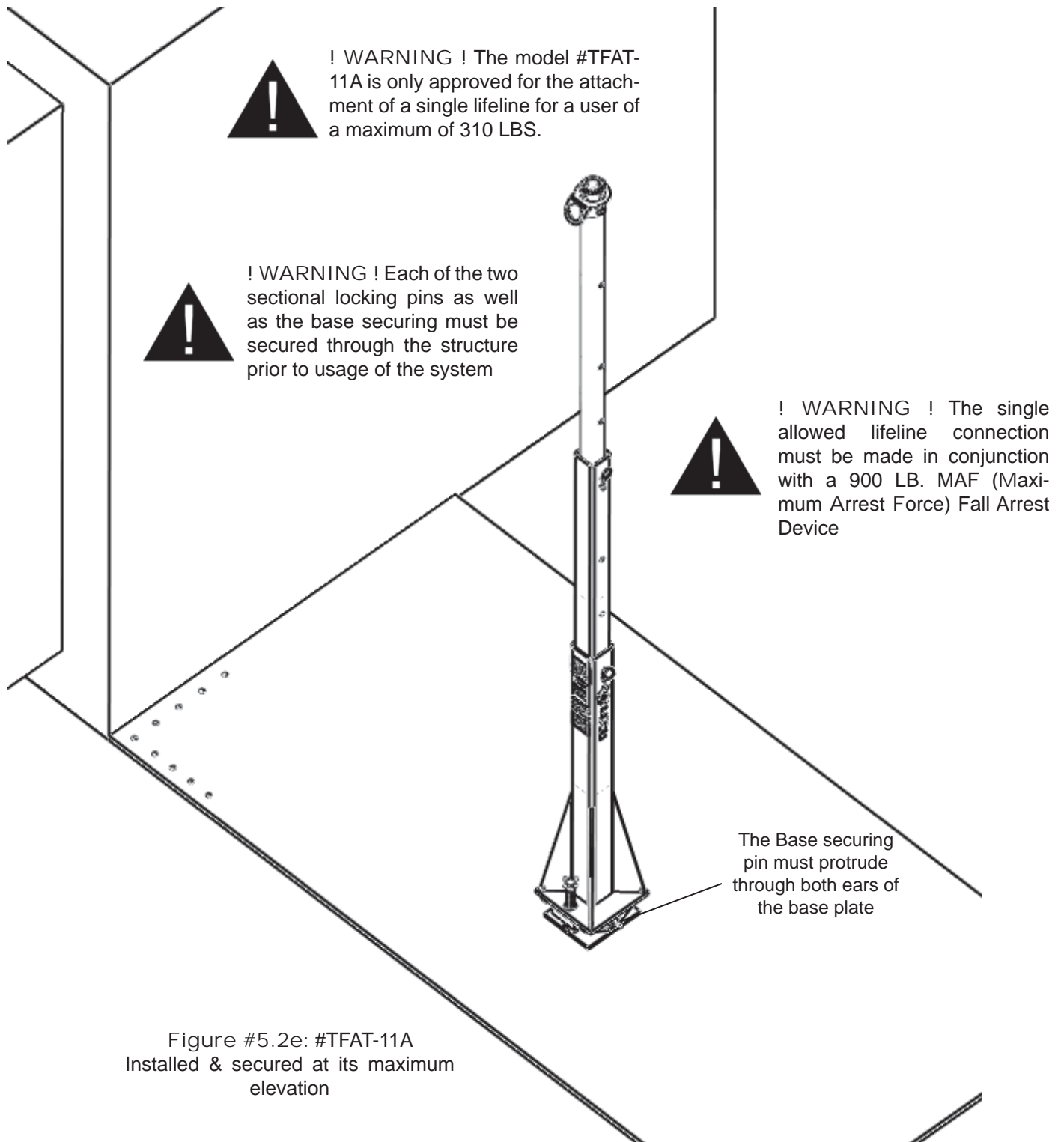

6.0 - Maintenance & Inspection



MAINTENANCE & INSPECTION

1. Read, understand and follow the Product Manual and all information located on the product before using, maintaining or inspecting the equipment.
2. ANSI and OSHA require a regular inspection program for all fall arrest equipment and to maintain documented results of these inspections. Follow the inspection procedure contained in this manual and use the inspection form to document the results.
3. Keep instructional and safety signs clean and legible at all times. Clean or replace as required.
4. Remove the equipment from service if a problem is found during the inspection. Return to an authorized repair depot or the factory for service.

6.1 - Maintenance

In general, the Model #TFAT-11A is intended to be a maintenance-free piece of equipment, however several steps can be taken to keep the system in top-notch working order and also extend the working life of the product.

Before Each Use:

1. Visual Inspection: Perform a complete visual inspection. Refer to section 6.2 for guidelines and take any maintenance steps that are necessary.

Annually:

1. Clean Product: Use a damp cloth and mild soap to clean the structure and labels of dirt and residue. Be sure that the labels are legible (replacements are available from Pelsue)
2. Lubricate the threaded screw pegs in order to ensure smooth operation.
3. Complete Inspection: Perform a thorough inspection, paying attention to the bullet points provided within section 6.2. Record the results and file the documentation for future reference. A log sheet has been provided in section 6.3 specifically for the recording of the dates & results of the annual system inspections.

Periodic Factory Service Inspection: It is recommended that the product be serviced by a factory authorized service center or the manufacturer after a period of three years. Extreme working conditions may indicate the necessity to increase the frequency. Factory servicing shall include but not be limited to an intensive inspection and cleaning of all internal and external components. Failure to provide proper service may shorten product life and could endanger performance or function.

6.2 - Inspection

When completing an inspection of the Model #TFAT-11A Telescopic Fall Arrest Tower, the following specific items should be checked;

1. Labels:

Check that all of the labels are clean and legible (Refer to Section 3.1). Clean the labels if any are dirty using mild soap and a damp cloth. Replace them if any are illegible. Decals & labels provide valuable warning and caution information applicable to product usage and limitations, and should be visible and present at all times.

2. Fasteners:

Check that all screws and other fasteners are present and secure. Note that not all fasteners are tightened to their maximum allowable torque. This is done in order to allow for pivoting and folding motions in certain components. Over-tightening of fasteners can interfere with the operation of the device and can damage the structure. Consult the Pelsue Company with any questions regarding fastener torque or specifications. All fasteners on the Model #TFAT-11A system are of a self-locking design. Bolt threads should extend all the way through their locking nuts. If

any fasteners have appeared to “back-out” or loosen the product should be removed from service until the problem can be identified and corrected.

3. Leveling Pegs:

Ensure that the Leveling Screws are in working condition. Oil or grease the threaded portions if required, and at least annually. Also, visually inspect and verify that both the internal and external threads of the leveling screw system do not contain an inordinate amount of debris or metal shavings and have not been otherwise damaged.

4. Structure:

The entire product structure should be checked for cracks, dents, bends or breaks. If there are major dents or any other structural damage, the unit should be removed from service and returned to the factory for evaluation and possible repair. If there is any question as to the structural integrity of the product, remove from service immediately and await further evaluation by a qualified organization or individual.

- Pay special attention to weld locations: look for cracks or separation at the welds. Keep in mind that the powder coating can age and crack, this normal paint cracking can be confused with structural cracking. If there is any uncertainty with regards to cracks, contact the Pelsue service department for assistance and/or recommendations
- Ensure that the three sections of the tower can move freely within one another when stood vertically and not supporting a load.
- Ensure that the swiveling anchor ring located at the tower’s apex rotates freely a full 360 degrees and does not bind. Also look for any deformation of the steel ring itself, and deformation may indicate a prior overload condition.

6.3 - Inspection Log (continued)

| Date | Labels | Pins & Fasteners | Leveling Screws | Overall Structure | Notes |
|----------------------------|--------|------------------|-----------------|-------------------|-------|
| | | | | | |
| Inspector (print & sign) : | | | | | |
| | | | | | |
| Inspector (print & sign) : | | | | | |
| | | | | | |
| Inspector (print & sign) : | | | | | |
| | | | | | |
| Inspector (print & sign) : | | | | | |
| | | | | | |
| Inspector (print & sign) : | | | | | |
| | | | | | |
| Inspector (print & sign) : | | | | | |
| | | | | | |
| Inspector (print & sign) : | | | | | |
| | | | | | |
| Inspector (print & sign) : | | | | | |
| | | | | | |
| Inspector (print & sign) : | | | | | |

7.0 - Storage

Prior to storage, the product should be thoroughly inspected and maintained. Repair or replace any worn or damaged components to prevent any unnecessary down time at the next use.

Follow this procedure:

1. Thoroughly clean the entire unit using a mild soap on the frame and labels.
2. Perform a complete inspection of the unit and document the results prior to storage.
3. Oil or grease hinges and moving components in order to prevent corrosion.
4. A #TFAT-11A series system can be dismantled for storage if desired, follow the reverse of the steps given for assembly in section 3.0 of this manual.

8.0 - Contact Information

For More Information...



T.A. Pelsue Company
2500 S. Tejon St.
Englewood, CO 80110

Toll Free: 1-800-525-8460
Telephone: 1-303-936-7432
Fax: 1-303-934-5581

Website: www.pelsue.com

Email: sales@pelsue.com



T.A. Pelsue Company
2500 South Tejon Street, Englewood, Colorado, USA 80110
Toll free 800-525-8460 or 303-936-7432 Fax. 303-934-5581
Internet: www.pelsue.com Email: sales@pelsue.com